



US 20140135593A1

(19) **United States**
(12) **Patent Application Publication**
Jayalath et al.

(10) **Pub. No.: US 2014/0135593 A1**
(43) **Pub. Date: May 15, 2014**

(54) **WEARABLE ARCHITECTURE AND METHODS FOR PERFORMANCE MONITORING, ANALYSIS, AND FEEDBACK**

(52) **U.S. Cl.**
CPC *A61B 5/0015* (2013.01); *A61B 5/0488* (2013.01); *A61B 5/6804* (2013.01)
USPC **600/301**; 600/546

(71) Applicants: **Dhananja Jayalath**, Redwood City, CA (US); **Christopher Weibe**, Redwood City, CA (US)

(57) **ABSTRACT**

(72) Inventors: **Dhananja Jayalath**, Redwood City, CA (US); **Christopher Weibe**, Redwood City, CA (US)

The present application relates generally to computer software, mobile electronics, wireless communication links, and wearable monitoring systems. More specifically, techniques, fabrics, materials, systems, sensors, EMG sensors, circuitry, algorithms and methods for wearable monitoring devices and associated exercise apparatus are described. A garment borne sensor system may generate data on a user's performance during exercise, for example, and the data may be analyzed in real time and feedback may be provided to the user based on the analysis. A piece of exercise equipment may be instrumented and in communication with the sensor system or other system and may be controlled in real time to adjust its settings to affect the user during the exercise routine. Communication between the sensor system and other systems may be wireless. Conductive structures formed directly in a fabric of the garment may integrally include sensors, circuitry, controllers, conductive traces, and sensor electronics.

(73) Assignee: **MAD Apparel, Inc.**, Palo Alto, CA (US)

(21) Appl. No.: **14/079,629**

(22) Filed: **Nov. 13, 2013**

Related U.S. Application Data

(60) Provisional application No. 61/726,470, filed on Nov. 14, 2012, provisional application No. 61/726,474, filed on Nov. 14, 2012.

Publication Classification

(51) **Int. Cl.**
A61B 5/00 (2006.01)
A61B 5/0488 (2006.01)

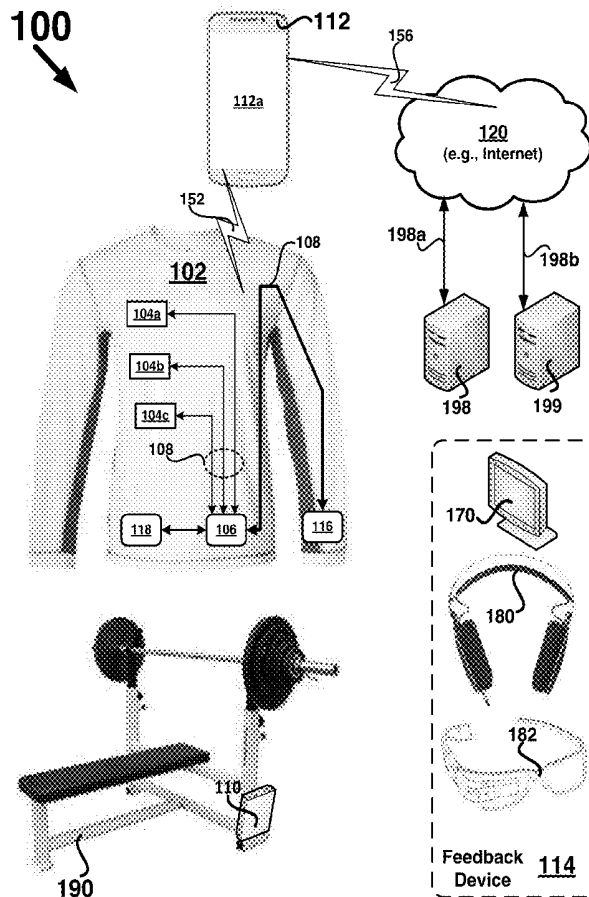

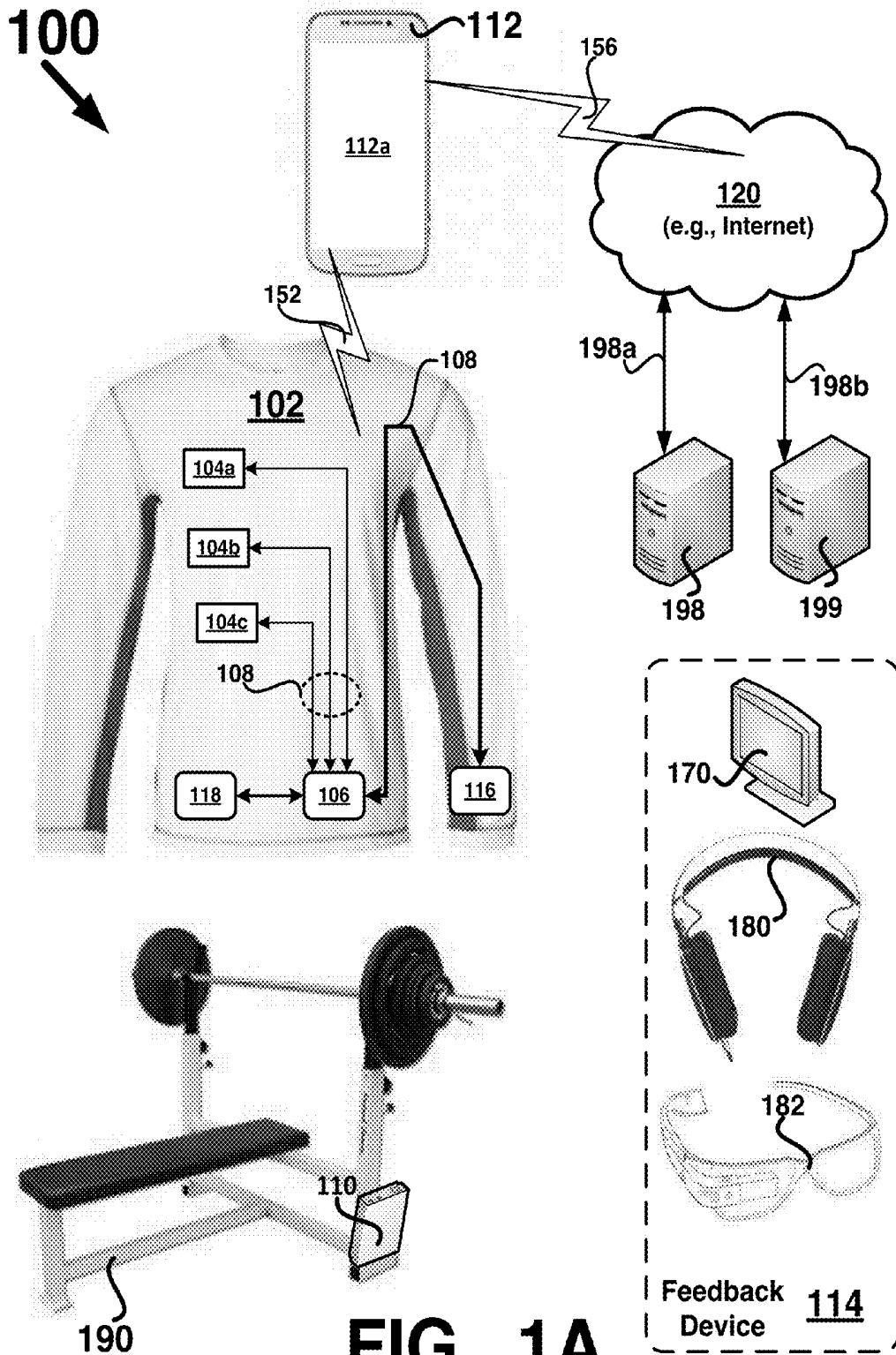

FIG. 1A

200
↓

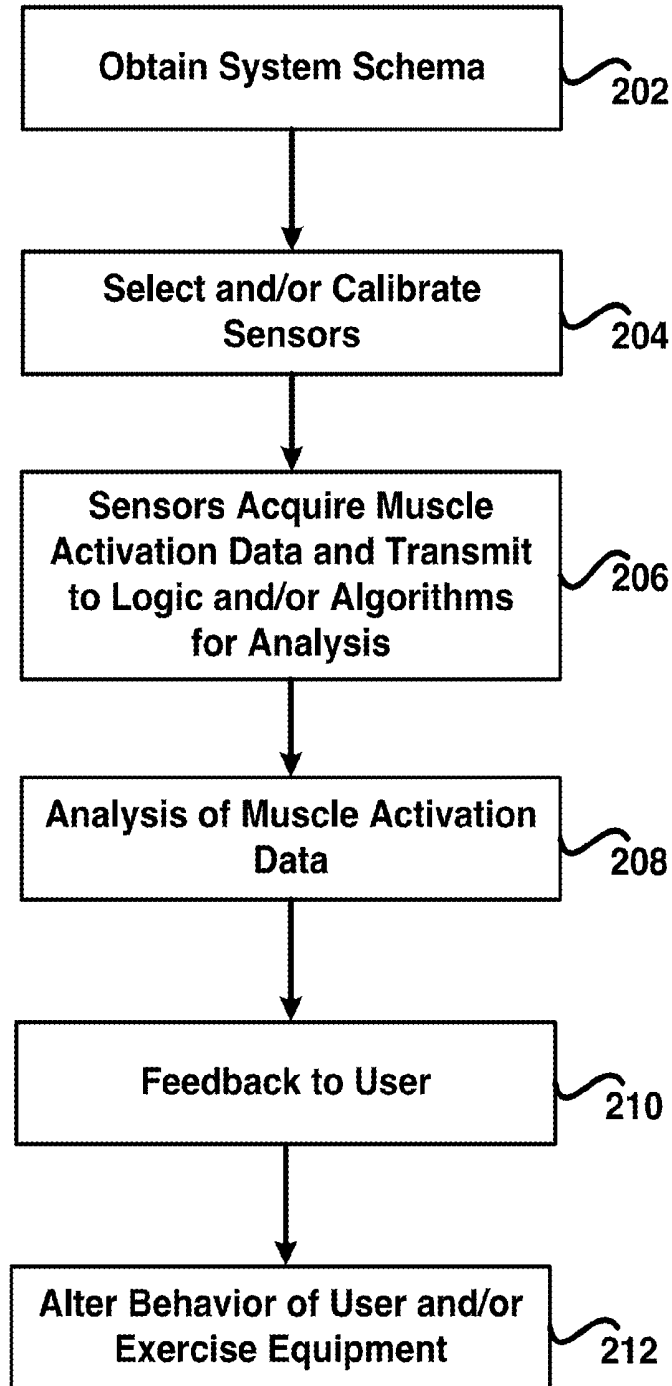

FIG. 2

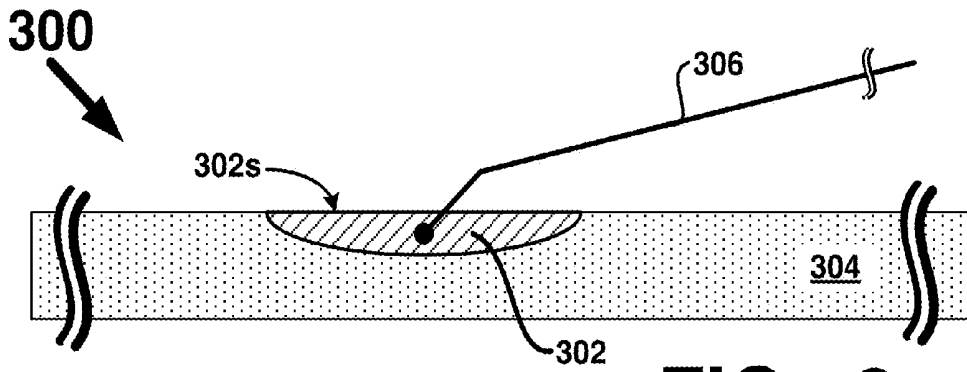

FIG. 3

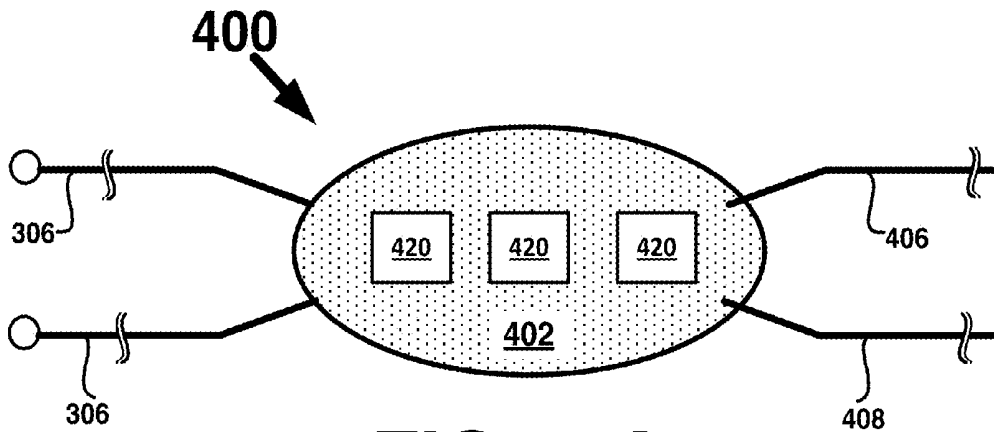

FIG. 4A

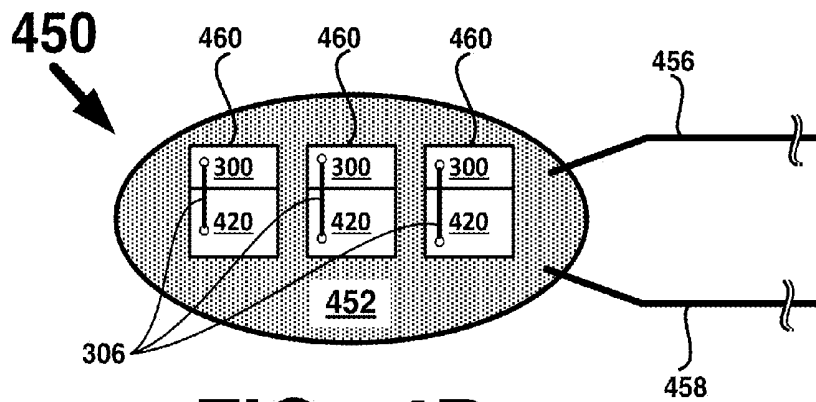

FIG. 4B

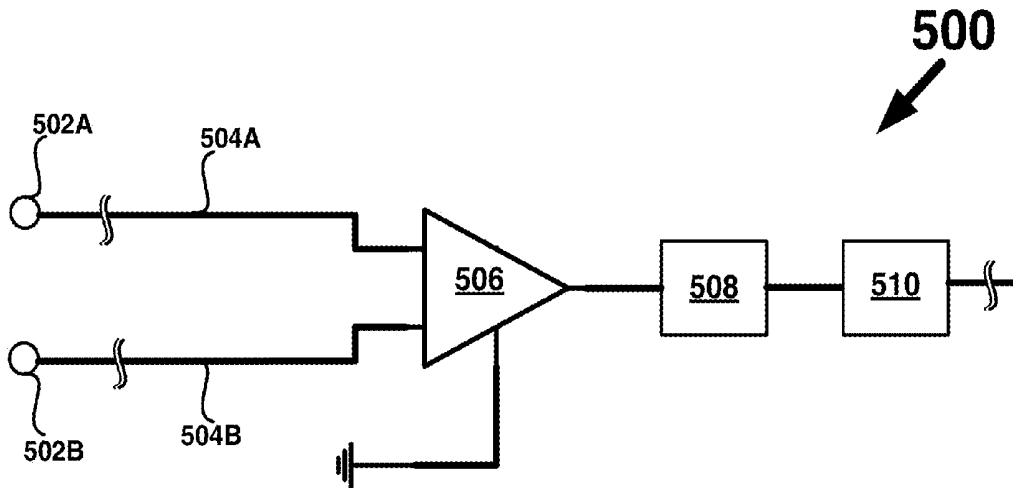

FIG. 5

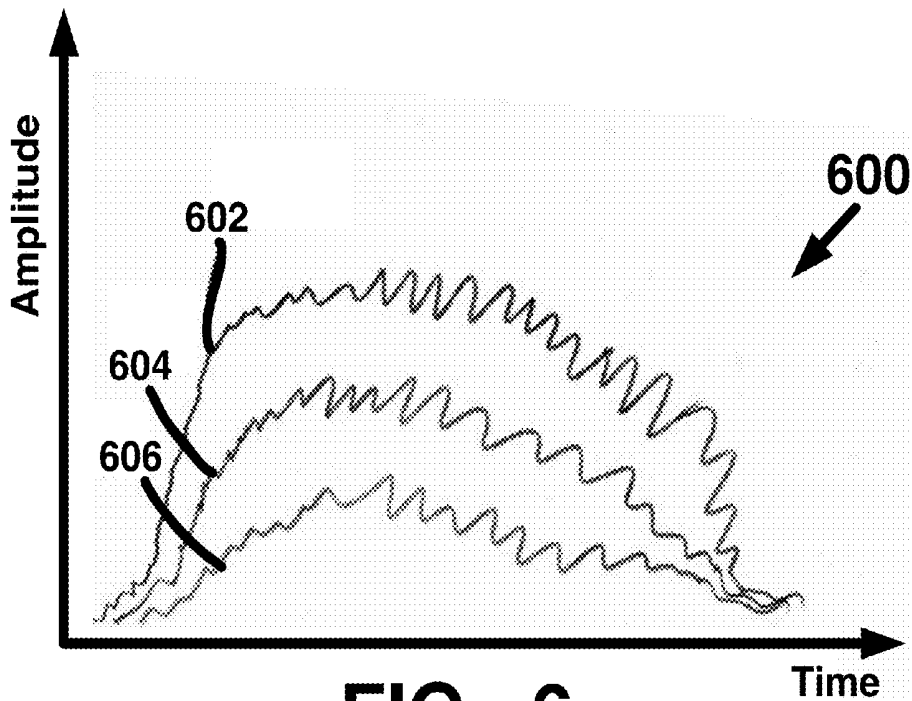

FIG. 6

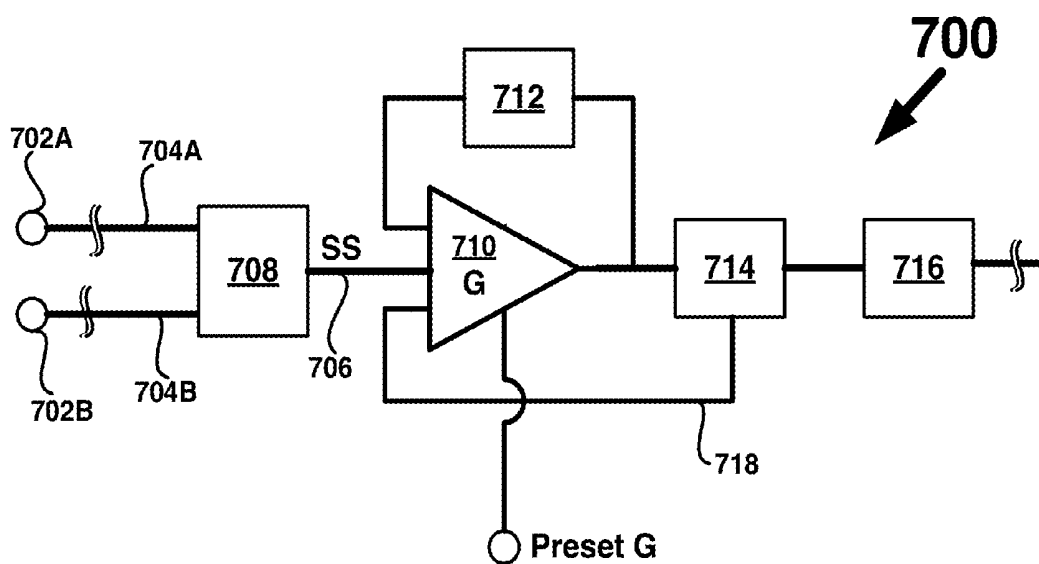

FIG. 7

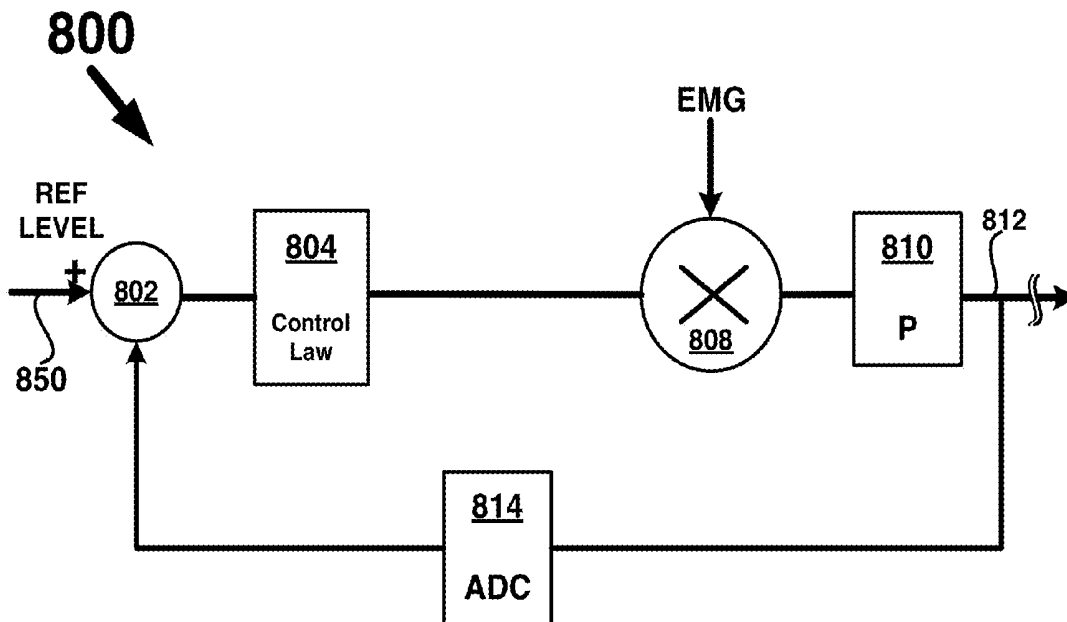

FIG. 8

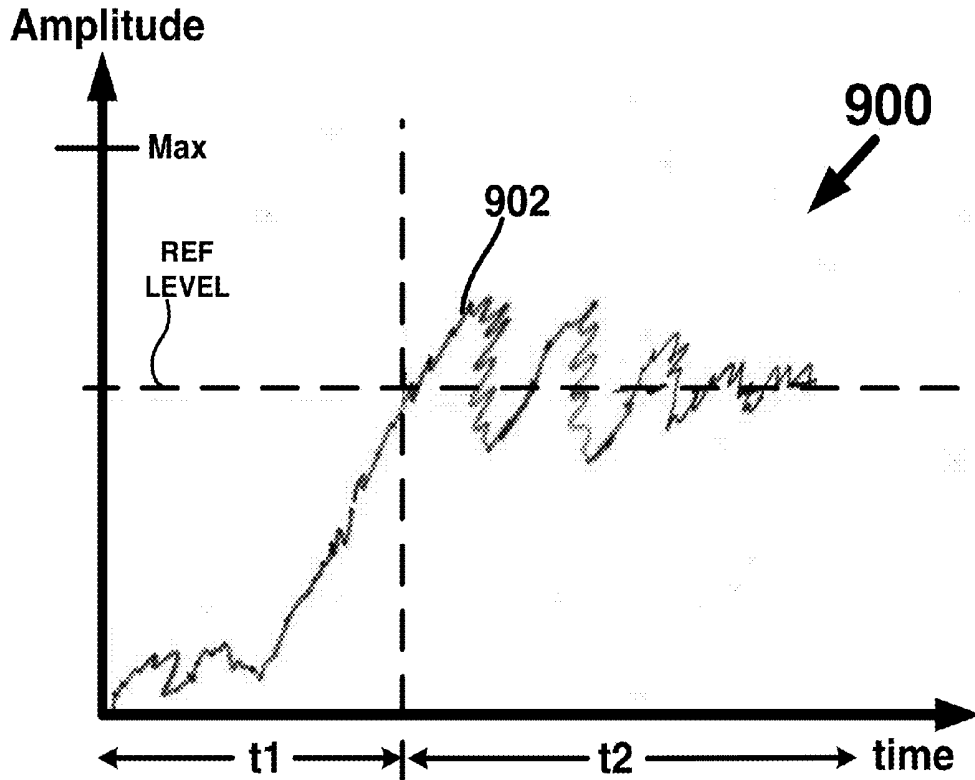

FIG. 9

**WEARABLE ARCHITECTURE AND
METHODS FOR PERFORMANCE
MONITORING, ANALYSIS, AND FEEDBACK**

CROSS-REFERENCE TO RELATED
APPLICATIONS

[0001] This application claims priority to the following U.S. Provisional patent applications: U.S. Provisional Patent Application Ser. No. 61/726,470, filed on Nov. 14, 2012, having Attorney Docket No. MADA-P001P1, and titled "Human Performance Monitoring, Analysis, And Feedback Systems And Methods Therefor"; and U.S. Provisional Patent Application Ser. No. 61/726,474, filed on Nov. 14, 2012, having Attorney Docket No. MADA-P002P1, and titled "Architecture And Methods For Human Performance Monitoring, Analysis, And Feedback", all of which are herein incorporated by reference in their entirety for all purposes.

FIELD

[0002] The present application relates generally to computer software, mobile electronics, wireless communication links, and wearable monitoring systems. More specifically, techniques, fabrics, materials, systems, sensors, EMG sensors, circuitry, algorithms and methods for wearable monitoring devices and associated exercise apparatus are described.

BACKGROUND

[0003] Human bio-potentials have long been measured in clinical settings for health and/or performance monitoring purposes. For example, the heart rate (HR) of a human test subject may be monitored in a health clinic or other health care venue using an electrocardiograph (ECG) system. In a typical electrocardiography test, a plurality of ECG electrodes may be adhesively attached to the skin of the human test subject in order to record information pertaining to the heart. The measured bio-potential information indicative of the heart functions may typically be recorded on ECG graph paper or stored in computer memory for later analysis.

[0004] In general, conventional ECG electrodes may be formed of a conductive gel embedded in an adhesive pad onto which a cable is coupled. Examples include an adhesive conductive hydrogel formed over a conductive rigid sensor to which the cable is coupled or otherwise attached. ECG electrodes may be adhesively attached to different locations on the skin of the human test subject to obtain heart-related information from different angles (e.g., left arm, right arm, left leg, etc.). The electrical signals obtained by the ECG electrodes may then be interpreted by a knowledgeable expert to obtain certain information pertaining to the heart functions (e.g., heart rate (HR), heart rhythm, etc.) as well as to detect symptoms of pathological conditions (e.g., hypocalcaemia, coronary ischemia, hypokalemia, myocardial infarction, etc.), for example.

[0005] There are some disadvantages to conventional gel-based electrodes. Gel-based and/or adhesive-based electrodes may be unsuitable for long-term monitoring applications. For example, gel-based and/or adhesive-based electrodes tend to dry out over time and thus tend to be one-time-use-only devices. Furthermore, gel-based and/or adhesive-based electrodes, such as those employing Silver-Silver chloride (Ag/AgCl) electrodes, may cause skin irritation to some human subjects, especially if those electrodes are

used over a long period of time. Moreover, the expertise and/or dexterity required to adhesively attach the gel-based and/or adhesive-based electrodes at various specific locations on the body often requires the use of an expert human assistant. The need for such expert involvement may be inconvenient and/or awkward for the user, and may drive up the cost associated with long-term monitoring.

[0006] The same issues may also render gel-based and/or adhesive-based electrodes unsuitable for use in the consumer market. For example, in addition to the aforementioned biocompatibility issue, consumers may be resistant to purchasing, using, and discarding one-time-use gel-based and/or adhesive-based electrodes due to cost concerns and/or environmental impact concerns. As mentioned above, the attachment of gel-based and/or adhesive-based electrodes at specific locations on the skin may be intimidating and time-consuming to an average consumer and may require a level of expertise and/or dexterity that an unaided consumer typically may not possess.

[0007] Conventional dry electrodes have been proposed as an alternative electrode that addresses the aforementioned shortcomings of gel-based and/or adhesive-based electrodes. Such conventional electrodes may be based on metal filaments incorporated into thread and woven in different patterns. Skin compatibility and reusability may be greatly enhanced by using dry electrodes.

[0008] Conventional dry electrodes and associated amplifying circuitry have been incorporated into textiles (e.g., garments), resulting in textile-based monitoring clothing. See, for example, "Fabric-Based Active Electrode Design And Fabrication For Health Monitoring Clothing" by Carey R. Merrit and H. Troy Nagle (IEEE Transactions On Information Technology In Biomedicine, Vol. 13, No. 2, March 2009). Textile-based monitoring garments based on textile monitoring fabric have further been manufactured and made commercially available by different manufacturers.

[0009] One of the seismic shifts in consumer electronic trends in recent years has been the increase in processing (e.g., multiple core and/or faster processors) and communication capabilities (e.g., WiFi, Bluetooth, NFC, Cellular, 2G, 3G, 4G, and 5G) of smart personal communication devices (SPCDs) and the ubiquitous nature of the Internet in everyday life. More importantly, SPCDs have been widely adopted by consumers and are ubiquitous in the consumer market. For example, SPCDs incorporating both cellular telephony capability and computer-like data processing and communication capabilities have been widely adopted by consumers for communication, work, Internet browsing, health, personal fitness, and entertainment (e.g., movie watching, gaming, streaming media, social and professional networking, etc.). Examples of such SPCDs include smart phones and tablets incorporating operating systems such as iOS™ (available from Apple, Inc. of Cupertino, Calif.), Android™ (available from Google, Inc. of Mountain View, Calif.), Windows™ (available from Microsoft Corporation of Redmond, Wash.), and the like. Well-known contemporary brands of smart phones and tablets include, for example, iPhone™, iPad™, Samsung Galaxy™, Motorola Droid™, BlackBerry™, etc. These SPCDs are now ubiquitous and possess powerful communication and processing capabilities. The popularity and utility of SPCD's have resulted in them being carried by their users at all times or at least being kept nearby and ready for use.

[0010] The ubiquitous nature of the Internet, the pervasiveness of wireless communications networks, and the wide-

spread adoption of SPCDs and their constant access and use by consumers has provided an opportunity to create comprehensive textile-based monitoring garment systems that may provide a level of capability and user-friendliness unavailable with the above mentioned conventional textile-based monitoring garment solutions.

[0011] Therefore, there is a need for improved electrodes, materials, ease of use, reduced costs and features in textile-based monitoring garment systems.

BRIEF DESCRIPTION OF THE DRAWINGS

[0012] Various embodiments or examples (“examples”) are disclosed in the following detailed description and the accompanying drawings:

[0013] FIG. 1A depicts an example of a simplified representation of various components of a textile-based human monitoring, analysis, and feedback (MAF) system;

[0014] FIG. 1B one example of various components of the textile-based human MAF system depicted in FIG. 1A;

[0015] FIG. 2 depicts an example use scenario for the textile-based human MAF system depicted in FIG. 1A;

[0016] FIG. 3 depicts one example of an electromyography electrode;

[0017] FIG. 4A depicts one example of an implementation of sensor electronics;

[0018] FIG. 4B depicts one example of an implementation of an electromyography electrode and sensor electronics;

[0019] FIG. 5 depicts one example of electronic circuitry in an example sensor;

[0020] FIG. 6 depicts three examples of signals sensed by the same form-fitting sensor garment on three different example human subjects;

[0021] FIG. 7 depicts an example of a high-level schematic diagram of a calibration circuit;

[0022] FIG. 8 depicts one example of an implementation of a calibration circuit; and

[0023] FIG. 9 depicts an example of a representation of an electromyography signal during calibration.

[0024] It is to be understood that, in the drawings, like reference numerals designate like structural elements. Also, it is understood that the drawings are not necessarily to scale.

DETAILED DESCRIPTION

[0025] Various embodiments or examples may be implemented in numerous ways, including as a system, a process, an apparatus, a user interface, or a series of program instructions disposed in a non-transitory computer readable medium such as a computer readable storage medium (e.g., RAM, SRAM, DRAM, ROM, Cache, Register, Flash, SSD, HDD, Volatile memory, Non-volatile memory, Optical media, Magnetic media, etc.) or a computer network where the program instructions are sent over optical, electronic, or wireless communication links. In general, operations of disclosed processes may be performed in an arbitrary order, unless otherwise provided in the claims.

[0026] A detailed description of one or more examples is provided below along with accompanying figures of the drawings. The detailed description is provided in connection with such examples, but is not limited to any particular example. The scope is limited only by the claims and numerous alternatives, modifications, and equivalents are encompassed. Numerous specific details are set forth in the following description in order to provide a thorough understanding.

These details are provided for the purpose of example and the described techniques may be practiced according to the claims without some or all of these specific details. For clarity, technical material that is known in the technical fields related to the examples has not been described in detail to avoid unnecessarily obscuring the description.

[0027] In some examples, the described techniques may be implemented as a computer program or application (“application”) or as a plug-in, module, or sub-component of another application. The described techniques may be implemented as software, hardware, firmware, circuitry, Integrated Circuit (IC), ASIC, FPGA, or a combination thereof. If implemented as software, the described techniques may be implemented using various types of programming, development, scripting, or formatting languages, frameworks, syntax, applications, protocols, objects, compilers, or techniques, including but not limited to ASP, ASP.net, .Net framework, Ruby, Ruby on Rails, C, Objective C, C++, C#, Adobe® Integrated Runtime™ (Adobe® AIR™), ActionScript™, Flex™, Lingo™, Java™, Javascript™, Ajax, Perl, COBOL, Fortran, ADA, XML, MXML, HTML, DHTML, XHTML, HTTP, XMPP, PHP, an objected oriented language, and others. Design, publishing, and other types of applications such as Dreamweaver®, Shockwave®, Flash®, Drupal and Fireworks® may also be used to implement the described techniques. Database management systems (i.e., “DBMS”), search facilities and platforms, web crawlers (i.e., computer programs that automatically or semi-automatically visit, index, archive or copy content from, various websites (hereafter referred to as “crawlers”)), and other features may be implemented using various types of proprietary or open source technologies, including MySQL, Oracle (from Oracle of Redwood Shores, Calif.), Solr and Nutch from The Apache Software Foundation of Forest Hill, Md., among others and without limitation. The described techniques may be varied and are not limited to the examples or descriptions provided.

[0028] In some examples, a form-fitting sensor garment may include at least one sensor (e.g., a bio-potential sensor) and associated processing and communications electronics. Typically, a pair of electrodes and associated electronics may form a sensor, which may receive as inputs a potential difference generated on the human skin due to ions flowing in muscle fibers as a result of muscle activity. In other examples, the one or more sensors may be washable sensors that may be borne or otherwise coupled with a garment and configured to be unaffected and/or undamaged by washing or otherwise cleaning or maintaining the garment. One or more form-fitting sensor garments may be made to be conformal to any part of the human body as desired. In other examples, one or more form-fitting sensor garments may be made to be conformal to any part of a structure, such as on the body of a non-human species (e.g., animals, mammals, pets, avian, livestock, equine, sea creatures, denizens of the deep, etc.), for example. Stretchable, compressive and form-fitting fabric made of natural or preferably synthetic fibers (e.g., nylon, lycra, polyester, spandex, or other suitable fibers and blends thereof) may be configured to exert a biasing force on the sensors, which are built-in to the form-fitting sensor garment, to bias (e.g., increase contact force) the washable sensors against the skin to maintain good electrical and/or mechanical contact and to reduce motion artifacts that may be caused if there is relative motion between the skin and the sensor(s) (e.g., the sensors and/or skin sliding against each other along their mutual contacting surfaces).

[0029] Biopotential sensors may include but are not limited to electromyography (EMG) sensors, ECG sensors, respiration, galvanic skin response (GSR), or others. Other types of sensors may also be incorporated into the form-fitting sensor garment. These auxiliary sensors may include but are not limited to accelerometers (single or multi-axis), GPS sensors, galvanic skin response (GSR), bioimpedance, gyroscopes, bend-angle measurement (flex) sensors (to measure joint angle or joint angles), etc. These sensors may be incorporated in a permanent manner into the fabric of the form-fitting sensor garment itself or in a detachable manner and/or in pockets or under or on top of flaps if desired.

[0030] The present application describes implementation of a combination of a multitude of sensors including, but not limited to electromyography (EMG), electrocardiograph (ECG), respiration, galvanic skin response (GSR), temperature, acceleration, bend angle, etc. The use of multiple sensors provides a level of insight that is not available by measuring only a single metric such as heart rate (HR) or motion based on accelerometers or other types of motion sensors (e.g., a gyroscope), as is currently available.

[0031] Conventional products do not enable washable electromyography sensors and associated electrodes attached to a form-fitting garment in the manners disclosed in one or more embodiments herein. The various combinations of embodiments disclosed herein that include electromyography sensors, dry electrodes, analysis and feedback methods, calibration and/or communication scope have not existed in conventional sensor garments.

[0032] In one or more embodiments, sensors may be incorporated into fabric or other material in a semi-permanent manner (using, e.g., loop-and-hook fasteners or other detachable fastening means) to allow re-positioning of the sensors.

[0033] In one or more embodiments, processing electronics may be configured to acquire the sensed signals from the electrodes and/or to amplify/filter the sensed signals from the electrodes. The sensors (e.g., fixed electrodes positioned in a fabric plus their associated electronics) may be incorporated into a form-fitting sensor garment in a permanent manner or a detachable manner. In some examples, the sensors are detachably mounted to the garment for a purpose including but not limited to re-positioning on the garment, repairs, replacement, upgrades, updates to software, sensor calibration, power source maintenance, to install on a different garment, to exchange for another sensor or type of sensor, just to name a few. Further, in one or more embodiments, processing electronics may be configured to perform data processing/analysis on the sensed data (which are derived from the sensed signals from the electrodes). Processing electronics may also be incorporated into the form-fitting sensor garment in a permanent or detachable manner. The processing electronics may also include one or more radios for wireless communication with external devices and/or other systems in the garment. For example, the processing electronics may comprise a system-on-chip (SoC) that may include one or more radios (e.g., BT, WiFi, NFC, etc.). As described herein, the term sensor may include one or more electrodes and associated sensor electronics (e.g., in a processor or other circuitry) electrically coupled with the electrodes and configured to acquire signals from the electrodes and to process the acquired signals in an analog domain, a digital domain or both. A sensor may comprise electrodes and associated sensor electronics integrated into a common structure (e.g., see **300** and **420** in **460** of FIG. **4B**) such as an electrode pad, or may

comprise electrodes and sensor electronics that are disposed remotely from one another, such as electrodes coupled to a remotely positioned processor (e.g., positioned at another location in the garment) or other circuitry using an electrically conductive structure such as a conductive trace, wire, cable, or the like, for example.

[0034] In one or more embodiments, communication electronics may be configured to transmit and/or receive information wirelessly and may be incorporated into the form-fitting sensor garment in a permanent or detachable manner. In one or more embodiments, a network of signal conductors may be configured to facilitate communication among the sensors and/or communication electronics and/or processing electronics may be permanently incorporated into the fabric of the form-fitting sensor garment.

[0035] To provide power to the processing electronics and/or communication electronics and/or sensors, a power source such as one or more batteries (which may be rechargeable by various means or may be one-time-use, disposable batteries) may be incorporated into the form-fitting sensor garment in a permanent or detachable manner. If the electronics and/or power source are/is non-detachable, it is preferable that these components are constructed such that they can withstand repeated washing and drying cycles typical of wearable clothing.

[0036] In the following discussion, electromyography sensors are described only as an example to facilitate discussion. It should be understood, however, that the present application contemplates that other types of sensor may be implemented additionally and/or alternatively to the electromyography sensors discussed in connection with the examples herein. In one or more embodiments, multiple washable electromyography (WE) sensors may be used to measure muscle activity at different sites on the human body. The WE sensors may be configured to measure muscle activity associated with different muscles to measure muscle exertion intensity. When groups of muscles are measured together, more complex analysis and feedback may be performed and made available to the user (e.g., wirelessly via an application (APP) running on a smartphone, tablet, pad, or the like).

[0037] In the following discussion, concepts of the present application will be described using athletics as well as strength and conditioning as an example application. The benefit of a garment that includes a multitude of WE sensors and specifically the ability to monitor multiple muscles, without requiring conventional adhesive based and manually placed alternatives may be utilized for other applications. The end use application in which the sensors and garment described herein may be used does not change the form or function of the concepts described in the present application. For example, applied to ergonomics the ability to critique form and posture discussed herein can be used to train proper procedures in a manufacturing environment, work environment, and athletic endeavors, just to name a few. Critiquing posture may provide injury prevention in the workplace in the same way as in an athletic training setting. As another example, in that the present application builds on clinical methods and provides a more user-friendly experience, the present application may be applied for use in self-guided rehabilitation and injury prevention training.

[0038] One example of the complex analysis and feedback possible using multiple WE sensors comprises a bench-press exercise routine because the bench press routine exercises a plurality of different muscles in the human body. By detecting

muscle exertion intensity associated with each of the plurality of muscles, information such as whether the human subject is using the proper form, whether a muscle is injured and compensation by one or more other muscles is taking place, whether the user is exercising with the optimal number of repetition and intensity, whether the full range of motion is involved, etc., may be acquired (e.g., from signals from multiple sensors) and provided as instant feedback to the user and/or to adjust the exercise the equipment (e.g., in real time) to optimize the exercise session. Other types of sensors (such as one or more of the aforementioned bend-angle measurement sensors, GSR, HR, temperature, and accelerometers, for example) may also provide information to enrich the analysis and feedback regarding the example bench-press routine.

[0039] In one or more embodiments, the set of WE sensors may be permanently incorporated into the fabric of the form-fitting sensor garment. In one or more embodiments, the form-fitting sensor garment may come in various sizes to accommodate various body sizes (e.g., similar to the sizing system currently used with exercise or casual clothing). In one or more embodiments, it is recognized that the difference in skin condition and/or subcutaneous fat content from human subject to human subject may give rise to data acquisition error if left uncorrected. For example, electrode acquired signals from a user with a higher body fat percentage may differ from electrode acquired signals acquired from a leaner user even though they both may weigh the same and may fit into the same size garment. The subcutaneous fat layer between muscle tissue and skin surface may attenuate an electromyography signal resulting in different acquired amplitudes for different body types. The electrode acquired signal may be calibrated, in one or more embodiments, to improve analysis and feedback accuracy.

[0040] In one or more embodiments, the number of electrodes/sensors that are built into the fabric exceeds the number actually required to obtain the necessary muscle activity data. Logic and/or heuristics may be employed to select the sensors that provide the best signals for the group of muscles of interest. This is particularly advantageous since the human subject may position the garment slightly differently at different times or in different work-out sessions. Further, the optimal measurement sites for one user may be different from the optimal measurement sites for other users. Prior to work out, intelligent logics and/or algorithms may be employed to select the optimal group of sensors on the form-fitting sensor garment to use for actual monitoring and analysis. As another example, the user may be guided to engage in a training or a teaching routine to allow the textile-based MAF's to properly recognize and select the optimal group of sensors on the form-fitting sensor garment to use in the actual monitoring and analysis. Signals from sensors that are not selected may be ignored or given less weight or may be employed in other ways, for example.

[0041] In one or more embodiments, all sensor data from all available sensors may be collected and/or stored (e.g., in memory), and analysis may be performed only on the subset of sensors that are relevant and/or deemed to generate most optimal signals for analysis. In other embodiments, only the relevant subset of sensor data may be collected and/or stored and/or analyzed. One or more of the collecting, the storing, or the analyzing may occur internally (e.g., on one or more processors or controllers in the garment), externally (e.g., in an external device such as the SPCD or other wireless device) or both.

[0042] In one or more embodiments, the design of the garment and geometry of the electrodes may be configured to account for variations in user body types and resulting alignment concerns. Intuitive features may be added to the garment to ensure proper alignment. These may include, but are not limited to, visible lines, markers and cut-outs for thumb, elbow, etc. For example, alignment marks or markers including but not limited to visible lines may provide a guide where the user only needs to ensure the line is straight for proper alignment. The electrode geometry may be designed to account for different muscle sizes. In one example, increasing a dimension of the electrode orthogonal to the muscle fiber direction may accommodate varying fiber radii and resulting muscle volume. In other examples, the garment may include designed structures configured to urge and/or force the user to correctly position the garment and its sensors with proper and/or orientation with respect to the muscles or other portions of the user's body to be sensed. For example, a shirt-like garment may include a cut-out portion for one or more body parts such as one for an elbow and another for a thumb and/or one or more fingers. The user aligning the elbow cut-out with the elbow of his/her arm and the fingers and/or thumb with their respective cut-outs may be used to ensure at least approximately accurate alignment of sensors in an arm portion of the shirt-like garment with the muscles in the arm that are to be sensed by the sensors disposed in the arm portion of the shirt-like garment. As another example, a pant-like garment may include for each leg, a heel loop and a knee cut-out configured to align sensors in a leg portion of the pant-like garment with the intended muscles in the user's legs. Other types of design structures may be configured into a garment where appropriate and may be used in conjunction with one or more alignment marks included with the garment. The above are non-limiting examples of designed structures and the present application is not limited to the above examples.

[0043] In one or more embodiments, the user may be given real-time feedback based on analysis of the sensor outputs. For example, pattern recognition algorithms may be employed to detect whether the muscle exertion data from a group of muscles indicates that the user is engaging in incorrect form or in a non-optimal workout. For example, exercises targeting the biceps brachii are meant to isolate exertion of that muscle from the rest of the body. A less efficient workout occurs when the user generates momentum using the shoulder and/or lower back. Identifying activity in these momentum-influencing muscles can determine incorrect form. Accelerometer or bend-angle data may be incorporated to complement the aforementioned. The feedback is preferably made in visual or audible form to allow the user to easily understand muscle activity and how to improve and/or correct a workout routine. In this manner, virtual coaching may be accomplished in real time to coach the user over the course of the workout.

[0044] In one or more embodiments, the form-fitting sensor garment may be part of a textile-based human MAF system. Processing and communication electronics on the form-fitting sensor garment may allow for data exchange (e.g., via a wireless communications link) with the exercise equipment, the smart personal communication device (SPCD), the feedback device and/or the Internet (e.g., computers implemented remotely and available via the Internet). In one or more embodiments, user-friendly techniques for pairing and communicating among the various components of the textile-based human MAF system are disclosed.

[0045] The features and advantages of various embodiments of the textile-based human MAF system may be better understood with reference to the figures and discussions that follow.

[0046] FIG. 1A depicted an example of a simplified representation of various components of a textile-based human monitoring, analysis, and feedback (MAF) system 100.

[0047] With reference to FIG. 1A, there is depicted a form-fitting sensor garment 102, representing a compressive, stretchable, and form-fitting garment to be worn by a human subject (not shown). Although form-fitting sensor garment 102 is shown to be a shirt, it can take any other garment form factor including but not limited to shorts, pants, elbow pad, knee pad, undergarment, neck wrap, glove, and the like, etc. A plurality of sensors 104A, 104B, and 104C are depicted as being disposed at various positions on the fabric of form-fitting sensor garment 102. As described above, a pair of electrodes and associated electronics may form a sensor, which may receive as inputs a potential difference generated on the human skin due to ions flowing in muscle fibers as a result of muscle activity. The associated electronics of the sensor may include filtering and impedance transferring. Although only three sensors (104A-104C) are depicted, it should be understood that there is no limit to the number and different types of sensors that may be employed and more or fewer sensors may be implemented than are depicted in the example of FIG. 1A.

[0048] In an embodiment, the electrodes of the sensor may be disposed on the inside of the garment such that they make direct contact with the skin generally at locations where muscles of interest are expected to be located adjacently when the form-fitting sensor garment 102 is worn. In another embodiment, the electrodes may be formed externally to the garment 102 so that they do not make direct contact with the skin but are electrically coupled to the bio potential signals from the skin proximate the electrodes position in the garment 102. As mentioned above, in an embodiment, redundant sensors may be incorporated into the garment to take into account the fact that the human subject may not wear the garment exactly the same way every time or different human subjects may be built differently. Also as mentioned, intelligent logic may then determine, from all available sensors, the optimal for use in monitoring performance in connection with a particular exercise routine. Moreover, as described above, designed structures, alignment marks, markers or other visual indicia may be positioned on and/or woven into, or otherwise integrated with the form-fitting sensor garment 102 to aid the user in correct placement of the sensors when putting on (e.g., donning garment 102) the form-fitting sensor garment 102. The designed structures, alignment marks or other visual indicia may be configured or otherwise designed to include an esthetic element, a logo, an icon, a fashion design, a distinctive pattern, or a color scheme, for example. In other examples, the alignment marks or other visual indicia may serve a variety of purposes, such as in machine/computer vision analysis of the motion of the human subject's body during an activity being monitored by the sensors 104A-104C, where a machine/computer vision apparatus may use the alignment marks or other visual indicia to track body motion or motion of a portion of the body the alignment marks or other visual indicia are positioned on. Analysis of sensor data from the sensors as well as data from the vision analysis (e.g., in real-time) may be used for a variety of purposes including but not limited to coaching the user,

physical therapy, choreography, stunts and/or special effects in movies and/or TV, athletic pursuits, competitions, or other endeavors that involve motion of the body. Other sensors such as gyroscopes, magnetometers, accelerometers, temperature, GSR, HR, bioimpedance, etc., may be used in in some combination in conjunction with sensors 104A-104C and the machine/computer vision apparatus.

[0049] Typically, electrodes of sensors 104A-104C may be a solid conductive material bonded or woven or a conductive resin (e.g., polymers, silicone, neoprene, thermoplastics, etc.) applied through a screening, printing or gluing process, or combination thereof, in either a permanent or detachable manner, to the fabric or to another conductive substrate attached to the fabric of the form-fitting sensor garment 102. The electrodes may be formed from a flexible PCB substrate (e.g., Kapton or other laminates) that may be bonded to the garment 102. Thus, unlike the conventional electrodes described above, the user does not have to manually attach the electrodes to different specific locations on the skin in the manner required for conventional physiological monitoring apparatus. In the example herein, sensors 104A-104C may be washable electromyography sensors although it should be understood, as mentioned, that other types of sensors may well be alternatively or additionally employed. Preferably, sensors 104A-104C are constructed such that they may withstand repeated wash-and-dry cycles typical of wearable clothing. In other examples, sensors 104A-104C are constructed such that they may withstand repeated wash-and-hang-dry cycles typical of wearable clothing. Form-fitting sensor garment 102 may be made from materials, circuitry, structures or the like that may be amendable to any number of wash cycles (e.g., in a washing machine or hand washing) and/or drying cycles (e.g., in a gas or electric dryer). Form-fitting sensor garment 102 may be made from materials, circuitry, structures or the like that may be amendable to dry-cleaning processes and the chemicals used in dry-cleaning processes. However, in some applications it may be preferable to hang-dry (e.g., air dry) garment 102, to preserve an appearance of the material (e.g., fabrics, colors, dyes, etc.) used for the garment 102, to prevent dryer lint or the like from gathering on the garment 102, and to prevent damage to the garment 102, its electronics, fabrics, sensors, or the like due to inadvertently drying the garment 102 at too high a temperature. In some applications garment 102 may be configured for machine drying, air drying, or both. Actual washing and/or drying instructions and/or processes for the garment 102 will be application dependent and are not limited to the examples described herein.

[0050] A controller 106 may be coupled with sensors 104A-104C via a network of flexible signal conductors 108 (which may be electrically conductive or optical). In one embodiment, sensors 104A-104C may communicate with controller 106 via a wired (e.g., hard wired) interface. In another embodiment, sensors 104A-104C may communicate with controller 106 via a wireless interface that may use a variety of wireless protocols including but not limited to NFC, Bluetooth, any variety of 802.x, just to name a few. Preferably, signal conductors 108 may be constructed such that they can also withstand repeated wash-and-dry cycles or wash and hang-dry cycles that typical of wearable clothing. Bonded insulated conductors, such as Kapton and laminate based printed circuit boards, wire, cable, coaxial conductors, shielded conductors, flexible printed circuits (FPC), flat flexible cable (FFC), electrically conductive threads, or silk-

screened/printed electrically conductive resins are examples of technologies that may be used to implement signal conductors **108**. In some examples, sensors **104A-104C** may communicate with controller **106** using a combination of wired and wireless communications links. Controller **106** may comprise one or more controllers or one or more processors. In some examples controller **106** may alternatively be referred to as a processor or processor **106**.

[0051] Typically, controller **106** may include communication electronics (e.g., one or more radios for a wireless communications link) to permit form-fitting sensor garment **102** to communicate (e.g., wireless data) with one or more of exercise equipment communication device **110**, smart personal communication device (SPCD) **112** (e.g., a smart phone, tablet, or pad), feedback device **114** (if such feedback device is other than SPCD **112**), or the Internet **120** via an appropriate router/access point arrangement, such as a wireless network (e.g., Bluetooth (BT), BT Low Energy, NFC, WiFi, any variety of IEEE 802.x, etc.). The electronics for implementing controller **106** may be permanently attached to the fabric of form-fitting garment (in which case controller **106** may be constructed such that it can withstand repeated wash-and-dry and/or wash and hang dry cycles typical of wearable clothing) or may be detachable from the garment **102** prior to washing/drying the garment **102**.

[0052] Controller **106** may also include processing electronics for performing some or all required signal processing on the sensed signals acquired from electrodes in sensors **104A-104C**. In one or more embodiments, such signal processing (e.g., amplifying or filtering) may be performed locally in one or more of the sensors **104A-104C**, at the controller **106**, or both, for example. Controller **106** may also include signal processing for performing data analysis and feedback data generation. In one or more embodiments, such data analysis and feedback data generation may be performed at one or more of controller **106**, SPCD **112**, feedback device **114** (if such feedback device is other than SPCD **112**), or the Internet **120**. Therefore, signal processing for performing data analysis and feedback data generation may occur solely in the garment **102** and its associated electronic circuitry, external to garment **102**, or both where some portion of the processing is done in the garment and other portions are done external to the garment **102** using processors and resources of external devices and/or systems. Controller **106** may include one or more processors, multi-core processors, one or more digital signal processors (DSP), one or more micro-processors (μ P), one or more micro-controllers (μ C), one or more application specific integrated circuits (ASIC), one or more field programmable gate arrays (FPGA), one or more analog-to-digital converters (ADC), one or more digital-to-analog converters (DAC), a system on chip (SoC), one or more operational amplifiers, custom logic, programmable logic, analog circuitry, mixed analog and digital circuitry, or the like, just to name a few. Garment **102** may include one or more radios configured to transmit, receive, or both, radio frequency (RF) signals for one or more wireless communications links as described above in reference to FIGS. 1A-1B. A plurality of radios may communicate using a plurality of wireless protocols and the plurality of wireless protocols may be different protocols.

[0053] FIG. 1A also depicts an example of an optional equipment detector (ED) **116**, representing a communication device (e.g., a wireless device) for obtaining information from exercise equipment communicating device **110**. ED **116**

may be included in controller **106** and need not be a separate block as depicted. Typically, it is contemplated that each piece of exercise equipment in a gym or other exercise facility may be equipped with its own exercise equipment communicating device **110** (e.g., a wired or wireless communications link). For example, exercise equipment communicating devices **110** may be implemented using RFID (Radio Frequency ID) devices, NFC (Near Field Communication) devices, some form of tag implemented in computer readable code such as QR (Quick Response) code or bar code, or even communication electronics that broadcast (e.g., wirelessly, either on its own or in response to an inquiry) information regarding the exercise equipment (e.g., **190**) or the types of exercises that may be performed on the exercise equipment. The information from the exercise equipment communicating devices **110** may be read by equipment detector **116** in order to acquire the aforementioned information regarding the exercise equipment or the types of exercises that may be performed on the exercise equipment.

[0054] Electrical power for equipment detector (ED) **116**, sensors **104A-104C**, and controller **106** may be provided by a battery pack **118**, which may be attached to form-fitting sensor garment **102** in a permanent or detachable manner. Battery pack **118** may represent a one-time-use, disposable battery or may represent a rechargeable battery pack (e.g., Lithium-Ion, Nickel Metal Hydride, or the like) to be recharged for use via a charging port (e.g., a micro USB connector) implemented with battery pack **118** or on form-fitting sensor garment **102** or via a wireless charging technology such as inductive charging. The battery pack **118** (rechargeable or otherwise) may be configured to be replaceable (e.g., by the user) in the event the battery fails or to swap out a battery with low charge or no charge, with a freshly charged battery, for example. Battery pack **118** may be configured to accept batteries with different amp-hour capacities to provide sufficient duration of operation of garment **102** and its associated electronics, such as 1500 mAh, 3000 mAh, etc. Battery pack **118** may be configured to endure several wash cycles, dry cycles or both. Alternatively, battery pack **118** may be configured to be removable from garment **102** when the garment **102** is to be washed and/or dried.

[0055] FIG. 2 depicts an example use scenario **200** for the textile-based human MAF system **100** depicted in FIG. 1A. The stages depicted in FIG. 2 may be better understood when reviewed together with FIG. 1B which depicts one example of various components of the textile-based human MAF system **100** depicted in FIG. 1A. Components depicted in FIG. 1B may have similar reference numbers to components depicted in FIG. 1A and may be intended to represent similar components.

[0056] Referring again to FIG. 2, at a stage **202**, a system schema is obtained. As the term is employed herein, the system schema may represent the reference muscle exertion data associated with a given exercise. For example, a bicep curl exercise may be represented by a system schema that specifies the level of exertion that should be experienced by the bicep muscle (e.g., fairly high) and lower back muscle (e.g., fairly low). The system schema may include one or more other schemas including but not limited to a user schema, a workout schema, and an environmental schema, just to name a few. System schema may be a combination of workout and/or exercise parameters, user specific parameters (e.g., BMI, percent body fat, weight, etc.), or electrode environmental parameters (e.g., sweat, body hair, etc.).

[0057] In accordance with a highly advantageous aspect of the present application, a system schema associated with a particular exercise may be automatically obtained in a user-friendly manner (e.g., wirelessly) without requiring data entry by the human subject. In an embodiment, equipment detector (ED) 116 may be brought into range (e.g., wireless range or near-field wireless range for NFC) or enabled to read information from or communicate with exercise equipment communicating device 110, which is affixed to the exercise equipment (e.g., a bench press machine 190 or other piece of equipment) or associated therewith.

[0058] Information (e.g., data) obtained from exercise equipment communicating device 110 may be as simple as a code that identifies the exercise equipment (e.g., “bench press equipment”) or the exercise to be performed (e.g., “bench press”). This information may be relayed (e.g., wirelessly) from ED 116 to controller 106 (e.g., see paths 150/152 in FIG. 1B) so that controller 106 may decode the information to obtain the system schema at the stage 202.

[0059] Alternatively, the information acquired by ED 116 may be relayed from ED 116 to controller 106 and then to SPCD 112 (e.g., see paths 150/152/154 of FIG. 1B) so that SPCD 112 may decode the information to obtain the system schema. Alternatively, the information may be further relayed from SPCD 112 to the Internet 120 (e.g., see paths 150/152/154/156) or from controller 106 to the Internet 120 and bypassing SPCD 112 (e.g., see paths 150/152/158). One or more computers 198 and 199 may be implemented remotely and may communicate (198a, 198b) via Internet 120 may then decode the relayed information to obtain the system schema and to send the information back.

[0060] Alternatively, the information from the exercise equipment communicating device 110 may be obtained directly by controller 106 and may bypass ED 116 (e.g., see path 160) or by SPCD 112 and may bypass both ED 116 and controller 106 (e.g., see path 162). For example, controller 106 or SPCD 112 may directly read or sense the information from exercise equipment communicating device 110 in one or more embodiments. After direct acquisition by controller 106 or by SPCD 112, the information from exercise equipment communicating device 110 may be processed in any of the manners discussed above (e.g., by controller 106, by SPCD 112, or by Internet 120 via any other paths depicted in FIG. 1B) to obtain the system schema at the stage 202. In some examples Internet 120 may be a resource such as a web site, web page, cloud storage, cloud computing, a server farm, network attached storage (NAS), RAID storage, or other resource that may provide compute engines (e.g., 198, 199) and/or data storage. Computers 198 and 199 may be directly coupled with data storage (not shown) or in communication with external data storage (e.g., Internet 120) (not shown). Examples of data storage include but are not limited to hard disc drives (HDD), solid state drives (SSD), RAID, NAS, Optical Disc, Flash memory, just to name a few.

[0061] In one or more examples, the information provided from exercise equipment communicating device 110 to ED 116 or controller 106 or SPCD 112 (e.g., depending on implementation) may be as complete as the entire system schema itself. In this example, no decoding is necessary to obtain the system schema at the stage 202.

[0062] In an additional example, SPCD 112 may retrieve the system schema at the stage 202 from a locally stored and pre-determined workout regimen or from the Internet 120

based on a user profile, for example. In this example, information from communicating device 110 may not be required.

[0063] Referring again to FIG. 2, sensors 104A-104C may be selected and/or calibrated in preparation for monitoring at a stage 204. Sensor selection may be performed if the form-fitting sensor garment 102 has redundant sensors. Calibration may be performed to take into account effects including but not limited to different body fat percentages, BMI's, bodily hair, or other factors associated with different human subjects, for example.

[0064] At a stage 206, muscle activation data may be acquired by sensors 104A-104C (or other sensors) while the user performs the exercise and transmitted to logic for analysis. The muscle activation data may be communicated via signal conductors 108 (as mentioned in connection with FIG. 1A) to controller 106. Analysis may be performed at controller 106 if controller 106 is endowed with logic and/or algorithms (e.g., software and/or hardware and/or firmware) to perform the analysis (in which case controller 106 may have to access to the earlier discussed system schema at the stage 202 for analysis purpose). This is shown by a path for signal conductors 108 in FIG. 1B. Although all of the sensors 104A-104C are depicted directly coupled to a single controller 106, it should be understood that such coupling may be an actual/physical coupling or may be a logical coupling. For example, multiple controllers (e.g., multiple controllers 106) may cooperate to share the data processing task or to relay information from one or more sensors to the appropriate controller or controllers for further data processing.

[0065] Alternatively, the muscle activation data may be communicated from sensors 104A-104C to controller 106 and then may be relayed to SPCD 112 for analysis (in which case SPCD 112 may have access to the earlier discussed system schema at the stage 202 for analysis purpose). This is depicted by paths 108/154 in FIG. 1B.

[0066] At this point, a short description regarding wireless communication may be useful. Typically, wireless communication among components of textile-based human MAF system 100 may employ any suitable air interface, including for example Bluetooth™ (in its various implementations, including low power Bluetooth), ANT™, WiFi™, WiMAX™, infrared, cellular technology (such as for example GSM™, CDMA™, 2G™, 3G™, 4G™, 5G™, LTE™, GPRS™), etc. The selection of the appropriate air interface for communication depends on the air interface availability in the devices and/or at the location, cost, convenience, and/or other factors.

[0067] Alternatively or additionally, the muscle activation data may be forwarded from SPCD 112 to Internet 120 (e.g., via path 164/156 or path 108/154/156) or from controller 106 to Internet 120 bypassing SPCD 112 (e.g., path 108/158) for analysis by one or more remotely implemented computers (e.g., 198, 199) through Internet 120.

[0068] Alternatively, the muscle activation data may be communicated from sensors 104A-104C directly to Internet 120 for analysis (in which case the sensors 104A-104C may be equipped with communication circuitry such as wireless communication circuitry, and computers (e.g., 198, 199) implemented via the Internet 120 may have access to the earlier discussed system schema at the stage 202 for analysis purpose). This is shown by example path 178 in FIG. 1B. Computers (e.g., 198, 199) may be in wired or wireless communication (198a, 198b) with the Internet 120.

[0069] In accordance with a particularly advantageous aspect of the present application, analysis may be performed not only on a single muscle, but on a plurality of muscles in accordance to the system schema at the stage 202. Analysis may be performed at one or more of the controller 106, the SPCD 112, the Internet 120, or any combination thereof, for example.

[0070] Analysis at a stage 208 may include, in one or more embodiments, comparing the exertion level of individual muscles (e.g., obtained from the muscle activation data from the sensors 104A-104C) with the reference exertion level of those muscles (e.g., obtained from the system schema at the stage 202). This analysis may reveal, for example, whether the human subject is performing the exercise at the appropriate intensity level (e.g., by looking at the intensity data from the sensors 104A-104C and comparing such information with corresponding information in the reference system schema at the stage 202). This analysis may also reveal, for example, whether the human subject is performing the exercise incorrectly. This may be the case if, for example, one muscle in the group of muscles under monitoring by the sensors 104A-104C is over-exerted or under-exerted. Other sensor data such as bend-angle sensor data or accelerometer sensor data may be used to improve the accuracy of the analysis at the stage 208.

[0071] Analysis at the stage 208 may include, alternatively or additionally, comparing the duration of the exertion of individual muscles (e.g., obtained from the muscle activation data from the sensors 104A-104C) with the reference exertion duration of those muscles (e.g., obtained from the system schema at the stage 202). Analysis may include, alternatively or additionally, comparing the number of exertion repetitions in a set (obtained from the muscle activation data from the sensors 104A-104C) with the reference exertion repetitions for those muscles (e.g., obtained from the system schema at the stage 202).

[0072] Analysis at the stage 208 may include, alternatively or additionally accumulating an activity score based on an electromyography signal. Such a score may be in different resolution forms such as the overall body or individual muscles. This allows the user to compare intensity level as measured through muscle exertion over time.

[0073] Analysis at the stage 208 may include, alternatively or additionally determining the number of repetitions and an approximation of the weight used. Such analysis may be determined by statistical analysis on saved user data or by comparing the user data against a larger data set of all active users stored in Internet 120 in FIG. 2. User data may be stored on one of controller 106, SPCD 112 or equipment 110.

[0074] Analysis at the stage 208 may include, alternatively or additionally updating a user profile and comparing against profiles of one or more other users. In one embodiment, user profile data may include a history of workout sessions including overall exertion as well as individually monitored muscles. In another embodiment, profile data may include goals set by the user and additionally or alternatively challenges from other users (e.g., to motivate the user). For example, the challenges may come from other persons or users who may be associated with a social network (e.g., Facebook®, Twitter®), professional network (e.g., LinkedIn®), or the like. Through social and/or professional networking of user profiles including historical workout data, motivation is increased by the competitive environment created. Additionally, challenges may be proposed by the system

(e.g., controller 106 and/or other system in communication with controller 106). A combination of progressive challenges (e.g., a series of challenges, each with higher goals to be achieved) may lead the user to higher and higher levels as in a gaming scenario were gameification of the challenges may comprise the user taking on progressive challenges against goals set by the user, the system, others, or by other competitors in the game, for example.

[0075] In accordance with a particularly advantageous aspect of the present application, a result of the analysis at the stage 208 may be immediately communicated to the user at a stage 210 via a display 112a of device 112 (e.g., a smartphone, tablet, pad, eyeglasses 182, etc.) or an auxiliary feedback device such as devices 114 substantially in real time (e.g., immediately after data acquisition and analysis is completed, factoring in real-world delays in data transmission and processing). Feedback at the stage 210 may, for example, include a representation of the body and visually depict the muscles being exerted, along with a color gradient or an overlay with relative exertion or other data depiction scheme to communicate the intensity level and/or duration and/or number of repetitions associated with each muscle. The feedback at the stage 210 may also include recommendations (e.g., “push more with the left arm” “slow down when lowering your arm”) or warning (e.g., “do not swing while lifting”) or other coaching information while the human subject is performing the exercise. The feedback at the stage 210 may be alternatively or additionally be in the form of audio feedback (e.g., on SPCD 112 or device 180), in one or more embodiments.

[0076] Additionally, feedback at the stage 210 may be stored on either the controller 106, the SPCD 112 or the Internet 120 for later viewing and/or audio playback. In one example, after completing a set or portion of a workout session the user may “playback” visual features including the body representation with muscle depiction. This allows the user to get feedback at a time that is convenient and not during a strenuous activity. Other features can be added to compare the “playback” with other users who may be a part of the system environment. For example using a professional athlete as a benchmark of comparison.

[0077] Feedback device 114 may be implemented by a built-in display 112a of SPCD 112 (e.g., a LCD, OLED, touch screen, etc.) by an external display 170, by audio playback device (such as headset 180, which may be in communication with controller 106, SPCD 112, external display 170 and/or Internet 120), or by digital eyewear (see 182 in FIG. 1A). Feedback device 114 may provide feedback information in either graphical, video, or audio format to the user.

[0078] For example, the analysis result at the stage 208 (e.g., as a type of feedback at the stage 210) may be displayed on the display screen 112a of SPCD 112 after analysis by SPCD 112. Alternatively, the analysis result may be displayed (e.g., using wireless communication if necessary) on the display screen 112a of SPCD 112 if analysis takes place elsewhere (e.g., communicated via path 154 if analysis is performed on controller 106 or via path 156 if analysis is performed via Internet 120). Alternatively or additionally, the analysis result may be displayed on an external display 170 (e.g., communicated via path 172 or path 154/174 if analysis is performed on controller 106 or communicated via path 156/174 or path 176 if analysis is performed by Internet 120).

[0079] Alternatively or additionally, the analysis result at the stage 208 may be displayed on digital eyeglasses (see 182

in FIG. 1A) instead of external display 170. Alternatively or additionally, the analysis result at the stage 208 may be converted to an audio format and played back using a headset 180 (e.g., a wireless headset, earpiece, headphones, or the like).

[0080] In accordance with a particularly advantageous aspect of the present application, the analysis result at the stage 208 may be employed to alter the behavior of the exercise equipment 190 in order to improve the exercise experience and/or exercise efficacy for the human user at a stage 212. For example, if the user is perceived to employ bad form while exercising at the maximum intensity level, the resistance level of a stationary bicycle or the incline angle of a treadmill or the resistance level of a resistance exercise equipment may be automatically reduced (e.g., in real time, using a motor or transducer operating under the command of controller 106 or SPCD 112) in order to help improve the exercise form of the user. Contrarily, if the analysis at the stage 208 reveals that the user can rapidly perform the exercise without much muscle strain, the resistance level of a stationary bicycle or the incline angle of a treadmill or the resistance level of a resistance exercise equipment may be changed (e.g., in real time) in order to present a more meaningful or beneficial exercise to the human subject.

[0081] In accordance with a particularly advantageous aspect of the present application, the system schema at the stage 202 may be individualized and/or customized using user data such as the user's profile/objective data (e.g., BMI, weight, height, training experience, past exercise session data) or the users subjective input (e.g., training goal, desired exertion level/duration/number of repetitions/number of sets). Objective data could be simplified by asking the user to identify with visual representations (e.g., using a GUI on display 112a) of different body types to reduce the amount of manual input required. In this manner, the human subject's workout session may be individualized and/or customized when the muscle activation data is compared against the individualized and/or customized system schema at the stage 202.

[0082] In one or more embodiments, the system schema at the stage 202 may also be customized using social and/or professional network input. For example, recommendations from coaches or challenges from other workout partners may be employed to change the system schema at the stage 202 in order to provide the human subject with a more optimal workout session. Customization using social and/or professional network input may be accomplished in real-time (e.g., to optimize the present workout session) or may occur post workout in preparation for future workout sessions where the recommendations may be acted on to optimize the workout session.

[0083] In accordance with one or more embodiments, form-fitting sensor garment 102 (or more specifically controller 106 of form-fitting sensor garment 102) may automatically pair with SPCD 112. Pairing, in the context of the present invention, may pertain to the association of a specific device with another specific device to facilitate wireless data communication and/or wireless data security/confidentiality. Likewise, form-fitting sensor garment 102 (or more specifically controller 106 of form-fitting sensor garment 102) may automatically pair (e.g., BT pairing) with exercise equipment 190 (or more specifically with exercise equipment communication device 110 thereof). Likewise, SPCD 112 may automatically pair with exercise equipment 190 (or more specifically with exercise equipment communication device 110).

[0084] In one or more embodiments, form-fitting sensor garment 102 (or more specifically controller 106 of form-fitting sensor garment 102) may intelligently pair with SPCD 112 to reduce power consumption (e.g., from battery pack 118). In an example of intelligent pairing, the communication apparatus would be turned off during periods of inactivity, such as when the user is resting. When controller 106, through algorithmic implementation, detects the commencing of activity the communicating apparatus would be turned on and pairing completed. Likewise, form-fitting sensor garment 102 (or more specifically controller 106 of form-fitting sensor garment 102) may intelligently pair with exercise equipment 190 (or more specifically with exercise equipment communication device 110 thereof) to reduce power consumption. Likewise, SPCD 112 may intelligently pair with exercise equipment 190 (or more specifically with exercise equipment communication device 110) to extend battery life. In other embodiments, processor 106 may scan for sensor activity from one or more of the sensors (e.g., 104A-104C) and if no sensor activity is detected, then processor 106 may switch to a low power mode of operation (e.g., to conserve battery power). Upon detecting sensor activity, processor 106 may exit the low power mode, analyze the detected sensor activity (e.g., analyze signals from the sensors) and take appropriate action. In some examples, the appropriate action may comprise the processor 106 switching back to the low power mode of operation, because the signals analyzed were not indicative of the type of activity the sensor is intended to sense, for example. Lack of motion or other physical activity or lack thereof by user may serve to trigger entry into the low power mode of operation for processor 106. For example, sensor not detecting muscle activity may prompt processor 106 to switch to the low power mode of operation. Subsequently, detection of muscle activity may prompt processor 106 to exit the low power mode of operation. As another example, a motion sensor (e.g., an accelerometer, motion detector, or gyroscope) may output a signal indicative of no motion or motion below a threshold indicative of sufficient activity by user and that signal may prompt processor 106 to switch to the low power mode of operation. Subsequently, motion detector may generate a signal indicative of sufficient activity by user (e.g., running, walking, etc.) and processor 106 may switch out of the low power mode of operation to another mode where the signal from motion detector is analyzed and acted on.

[0085] Likewise, form-fitting sensor garment 102 (or more specifically controller 106 of form-fitting sensor garment 102) may automatically pair with the external display 170 or the headset 180 or the digital eyeglass 182 as described earlier. Likewise, SPCD 112 may automatically pair or otherwise establish a wireless communication link (e.g., via BT, WiFi, 2G, 3G, 4G, 5G, or other protocol) with one or more of the external display 170, the headset 180, or the digital eyeglass 182 as described above.

[0086] In an example, pairing may be assumed when two communication devices establish wireless communication (e.g., such as by the act of bringing the two devices closer together or by passing the devices over one another or tapping the devices together as in NFC or other low power close proximity RF protocol, or causing one device to communicate with another device). In one or more embodiments, the proposed pairing may be detected and optionally presented to the human subject (e.g., such as via a display screen 112a of SPCD 112) for approval by the human subject prior to the actual pairing. In this manner, pairing may be made automatic

(e.g., with no user intervention) or substantially automatic (e.g., with minimal user intervention), greatly improving user friendliness aspect of the textile-based human MAF system 100.

[0087] In one or more embodiments, sensor data and/or analysis data may be time-stamped and automatically stored in one or more of controller 106, SPCD 112, and remote computer (198, 199) via Internet 120 in order to build up one or more user profiles over time, for example. This user profile data may be employed for historical analysis of workout sessions for a particular user, for customizing the system schema, for tracking workout progress, or for scientific/medical analysis by a third party, or for social/professional network sharing, and for challenges, for example. This aspect of automatic active management and updating the user profile presents a significant improvement over conventional workout data logging methods, which typically involve tediously manually writing down on paper or typing into an electronic device parameters regarding a workout session. Automatic parsing and data logging make it more likely that the user would continue to use the textile-based human MAF system 100.

[0088] In accordance with an aspect of the present application, statistical correlations may be made over time to predict the weight that the human subject employs in a particular weight training exercise. Since data pertaining to the type of exercise and the equipment (obtained from the system schema at the stage 202) and pertaining to the user profile (e.g., BMI, height, age, exercise history) is available, examples may correlate the weight employed (either input by the user initially via an appropriate input device or guessed by the system and confirmed or rejected by the human subject) with specific signature profile in the sensor signals. If a large set of such data is collected over time, statistical inferences may be made in the future to predict the weight being employed by the human subject even without an explicit input by the user pertaining to the weight employed. This statistical inference may be made based on, for example, the sensor signal amplitude or signature, the type of exercise and the equipment employed, the user profile, etc. Feedback by the human subject pertaining to weight prediction accuracy may be employed to refine the prediction model over time, thereby improving prediction accuracy as time goes by. Once weight prediction becomes more accurate and practical, record keeping may be further simplified since the user no longer has to manually enter the amount of weight used. Instant feedback and coaching may also become more meaningful when weight information is always accurately tracked and rendered available to the feedback/coaching logic.

[0089] In other examples, statistical correlation may also be made between sensor signals and exercise repetitions to automatically generate and log repetition data as the human subject exercises. Correlation can be made across multiple sensor signals to identify a particular workout or correlation on the signal itself to identify patterns representative or exercise repetitions. Likewise, statistical correlation may also be made between sensor signals and exercise duration to automatically generate and log duration data as the human subject exercises. Such duration data may be tracked with high granularity (e.g., time duration/repetition, time duration/set, time duration/exercise session, etc.) and with a high degree of consistency. Once repetition and duration information is automatically harvested, record keeping may be further simplified since the user no longer has to manually enter the repetition and dura-

tion information. Instant feedback and coaching may also become more meaningful when repetition and duration information is automatically tracked and rendered available to the feedback/coaching logic. Since information pertaining to the exercise involved and the exercise machine involved may also be automatically harvested and tracked, instant feedback, analysis, and coaching may be further enhanced.

[0090] Attention is now directed to FIG. 3 where one example of an electromyography electrode 300 is depicted. In FIG. 3, an electrode base 302 may be formed using a conductive resin (e.g., silicone, neoprene, rubber, polymers, thermoplastics, etc.). The electrode base 302 may be formed directly, in some examples, on fabric 304 of the form-fitting sensor garment 102. Electrode base 302 may be deposited by a process similar to painting such as silk-screening, printing, or other processes for depositing or otherwise forming an electrically conductive material on another material, such as on fabric 304, for example. One or more portions of a surface 302s of electrode base 302 may be urged into contact with skin of a user who dons garment 102. Surface 302s may have any shape or surface profile (e.g., planar, arcuate, undulating, etc.) and is not limited to the configuration depicted in FIG. 3.

[0091] A conductive lead 306, which may be formed of a conductive material (e.g., an electrically conductive material) or a fiber optic material (e.g., a plastic or glass fiber optic cable or optical waveguide), is depicted as being embedded in electrode base 302 and may serve as the signal conduit between the sensor electronics and the electrode 302. Conductive lead 306 may likewise be deposited by a process similar to painting such as silk-screening or printing or may be conductive traces laminated in a flexible and/or stretchable PCB substrate, flexible printed circuitry (FPC), or flat flexible cable (FFC), that is then adhered onto the garment 102 (e.g., on an interior or exterior surface of the garment 102). In some applications, it may be desirable for esthetic, industrial design, fashion, practical, or troubleshooting reasons to position some or all of the conductive lead(s) 306 on an exterior surface of the garment 102 so that they are visible to the human subject or others when the garment 102 is worn. Using the conductive lead(s) 306 for esthetic, industrial design, or fashion reasons may make the conductive lead(s) 306 hide in plain sight and not be recognized as conductive lead(s) 306 for a sensor enabled garment, but rather as design elements of an article of clothing or allow the garment 102 to be worn in scenarios (e.g., for casual dressing or as sporty clothing) other than those associated with sensing data from muscle activation as described herein.

[0092] In an embodiment, lead 306 may be permanently attached to electrode base 302. In another embodiment, lead 306 may be detachable, using a detachable connector configured to couple with a corresponding connector of electrode base 302. In either case, a pair of leads 306 coupled with two neighboring electrodes 302 may permit the sensor electronics to sense the potential difference between the electrodes 302 and outputs a difference between the potentials (or a processed version thereof) as an output signal(s).

[0093] FIG. 4A depicts one example 400 of an implementation of sensor electronics. In FIG. 4A, sensor electronics 420 (such as integrated circuits (IC's), ASIC's, FPGA's, programmable logic, conductors, circuit boards, and/or discrete components) may be embedded in a sensor base 402 to secure the electronic components of sensor electronics 420 in place as well as to protect the electronic components that comprise the sensor electronics 420 from the outside environment (e.g., exposure to the elements and/or physical damage). Sensor base 402 may preferably formed of a non-conductive resin (e.g., a non-conductive rubber-like potting material) and is preferably chosen for durability in the human exercise envi-

ronment as well as in repeated wash-and-dry cycles. Conductive leads 306, which are in electrical communication with electrode bases 302 of FIG. 3, may be coupled with the sensor electronics 420 of sensor base 402 in a permanent or detachable manner.

[0094] In an embodiment, sensor base 402 may be formed directly on the fabric or other material of the form-fitting sensor garment 102. As before, the sensor base 402 may be deposited by a process similar to painting such as silk screening or printing as described above for lead 306. Sensor base 402, along with the sensor electronics 420, may be permanently attached to the fabric of the form-fitting sensor garment or may be made detachable. Velcro or other mechanical fasteners may be employed if a detachable implementation is desired. An output lead 406 may be coupled, in a permanent or detachable manner, with the sensor electronics 420 to output the sensor signal(s). In an embodiment, signal communication may be wireless in which case an output lead (e.g., 306, 406, 408) may not be necessary. One or more conductors 408 may also be coupled with the sensor electronics 420, in a permanent or detachable manner, to provide power (e.g., from battery pack 118), ground, other signals, etc. In some examples, power for sensor electronics 420 may be positioned in or on sensor base 402. In other examples, sensor base 402 may be configured to be detachable from garment 102. Detachment may allow for one or more of sensor re-positioning on the garment 102, charging, replacing, or servicing a power source (e.g., rechargeable battery) for the sensor electronics 420. In yet other examples, sensor base 302 and sensor electronics 402 may be detachably connected with each other.

[0095] FIG. 4B depicts another example 450 of an implementation of a sensor 460 that includes sensor electronics 420 and electromyography electrodes 300 that are integrated into the sensor 460. In FIG. 48, sensor electronics 420 (such as integrated circuits (IC's), ASIC's, FPGA's, programmable logic, conductors, circuit boards, and/or discrete components) may be embedded in a sensor base 452 to secure the electronic components of sensor electronics 420 in place as well as to protect the electronic components that comprise the sensor electronics 420 from the outside environment (e.g., exposure to the elements and/or physical damage). Sensor base 452 may preferably be formed of a non-conductive resin (e.g., a non-conductive rubber-like potting material) and is preferably chosen for durability in the human exercise environment as well as in repeated wash-and-dry cycles. Conductive leads 306 or other electrically conductive structures in EM electrodes 300 may be coupled with the sensor electronics 420 of their respective sensors 460.

[0096] In an embodiment, sensor base 452 may be formed directly on the fabric or other material of the form-fitting sensor garment 102. As before, the sensor base 452 may be deposited by a process similar to painting such as silk screening or printing as described above. Sensor base 452, along with the sensors 460, may be permanently attached to the fabric of the form-fitting sensor garment or may be made detachable. Velcro or other mechanical fasteners may be employed if a detachable implementation is desired. An output lead 456 may be coupled, in a permanent or detachable manner, with the sensor electronics 420 to output the sensor signal(s). In an embodiment, signal communication may be wireless in which case an output lead 456 may not be necessary. One or more conductors 458 may also be coupled with the sensor electronics 420, in a permanent or detachable

manner, to provide power (e.g., from battery pack 118), ground, other signals, etc. In some examples, power for sensor electronics 420 may be positioned in or on sensor base 452. In other examples, sensor base 452 may be configured to be detachable from garment 102. Detachment may allow for one or more of charging, replacing, or servicing a power source (e.g., rechargeable battery) for the sensor electronics 420. In yet other examples, sensor base 302 for electrodes 300 and sensor electronics 420 may be detachably connected with each other in the sensor 460.

[0097] FIG. 5 depicts one example 500 of electronic circuitry that may be included in sensor electronics 420. The acquired signals from electrodes 502A and 502B (e.g., from leads 306) may be received by differential amplifier 506 via leads 504A and 504B respectively. Amplifier 506 may act as a voltage amplifier to amplify, in some examples, a difference between sensed signals. An output of amplifier 506 may be further processed via filter block 508 to amplify and isolate a frequency spectrum of a physiological signal.

[0098] In one example, an output signal from filter block 508 may be further processed, such as by rectification and/or other form of processing (see 510). Other forms of processing may include analog-to-digital-conversion (ADC), wireless transmission (e.g., via controller 106), for example. In another example, the sensor may only act as a buffering stage between the electrodes and the controller 106 (e.g., see 302, 402, and 420 in FIG. 3 and FIGS. 4A-4B). In an embodiment Digital Signal Processing (DSP) may be used instead of or in addition to the electronic circuitry in the sensor.

[0099] In some examples, the conductors that couple the electrodes to the sensors and/or the sensors to the controller (s) and/or other components on the form-fitting sensor garment may be formed using a flexible multi-conductor ribbon, which may be formed by for example printing or screening. The multi-conductor ribbon may be disposed on an appropriate flexible substrate on the fabric, in some examples. The substrate may be disposed or otherwise directly attached to the fabric of the form-fitting sensor garment 102, in one or more examples.

[0100] FIG. 6 depicts one example 600 of three example signals sensed by the same form-fitting sensor garment 102 on three different example human subjects. The signals in FIG. 6 represent an enveloped version of the signals obtained from the sensors (e.g., 104A-104C) without calibration. Many factors may affect the amplitude of the acquired physiological signal including but not limited to the thickness of the subcutaneous fat layer between muscle tissue and skin surface, body hair, strength and conditioning level, where higher level results in lower muscle fiber recruitment for a given required force, as well as possible nerve damage. Each of these factors acts to reduce the sensed electromyography signal. A remedy may include a calibration component providing flexibility to tune the system to a specific user for increased accuracy. Signals 602, 604 and 606 depict an example of a decrease in signal amplitude over time for a given force output as percentage body fat as well as strength and conditioning level increase for three different users. Differences in user specific data (e.g., different user profiles) may be one factor that accounts for differences in Amplitude between signals 602, 604 and 606 as depicted in the example 600 of FIG. 6. By modifying the signal level the system accuracy may be calibrated to a specific user irrespective of whether the human subject is thin, athletic, or has a high percentage of body fat.

[1011] FIG. 7 depicts a high-level schematic diagram of one example 700 of a calibration circuit. Signals from electrodes 702A and 702B are received by sensor electronics 708 via conductors 704A and 704B respectively. The output of sensor electronics 708 via conductor 706 may represent the sensed signal (SS) from muscle activity (e.g., from a human subject/user) as described above. This sensed signal SS may be input into a variable gain block 710, which may scale the sensed signal SS by a gain factor G (e.g., by multiplying an amplitude of SS by the gain factor G). The gain adjustment may be applied to the analog sensed signal SS to improve signal resolution once sampled.

[1012] In some examples, the gain factor G may be preset initially using, for example, the BMI value that is input by the human subject or associated with a graphic body type the user has identified with. The BMI value or other signal may be applied to input node "Preset G" of variable gain block 710. BMI represents the Body Mass Index, a measurement that evaluates the body fat percentage of an individual and is only one possible metric from which an initial gain level G may be set. By comparing the BMI of the user to a remote dataset, stored on the Internet 102 as an example, an appropriate BMI value can be determined using statistical analysis. This is only one example of how gain information may be acquired from the user or the user profile, although other parameters (or derivatives thereof) may also be used.

[1013] In an additional examples, the gain factor G may be modified by the feedback output of block 714 in FIG. 7. Block 714 may represent a processing block such as a microcontroller (μ C), microprocessor (μ P), or FPGA. By analyzing the acquired signal in block 714 the gain G may be adjusted either directly through path 718 or indirectly through block 712.

[1014] Referring again to FIG. 7, gain G for variable gain block 710 may be adjusted (e.g., in steps) based on a preset value (e.g., a value on Preset G) from the aforementioned user profile as well as by comparing signal level(s) (e.g., on 702A and/or 702B) to a reference value. In FIG. 7, the signal for gain G (e.g., a value on Preset G) may be an analog signal(s) or a digital signal(s). Data for the user profile may be communicated to controller 106 wirelessly from an external source as described above in reference to FIGS. 1A and 1B. Data for the user profile may also be communicated via 108 to controller 106 by the equipment detector (ED) 116 which may be wirelessly communicated to ED 116 by an external source as described above in reference to FIGS. 1A and 1B. Controller 106 may process or otherwise analyze the user data, and optionally other data or signals and output a signal that is electrically coupled with the Preset G node of variable gain block 710 to set gain G. Here gain G may be adjusted in steps or other increments based on preset or dynamic values for the user profile. An output signal from controller 106 may comprise one or more analog signals or one or more digital signals that are coupled with the Preset G node of gain block 710.

[1015] FIG. 8 depicts an example 800 of one form of implementing the feedback as may be facilitated by block 714 of FIG. 7. Blocks 808 and 810 may be associated with block 710 of FIG. 7 and the remaining blocks of FIG. 8 may be associated with block 714 of FIG. 7. A signal from block 810 may represent an analog input to the processing block 714 and a signal from block 814 may be a sampled value available for processing. The sampled value may be compared to a reference level REF LEVEL 850, REF LEVEL 850 may be set and/or modified from a user metric associated with the user

profile, or from statistical analysis running on a large user based Internet dataset, such as one in communication with Internet 102, for example. Block 804 may represent a Control Law which is implemented as an algorithm(s) in processing block 714. The Control Law may act to minimize an error between the reference level and the sampled signal level by increasing the amplitude of an EMG signal through block 808. Block 808 may represent gain G of block 710 of FIG. 7. Block 810 may represent a frequency response or a transfer function of block 710.

[1016] FIG. 9 depicts an example of a representation of an electromyography signal 902 during calibration. A time period t1 may represent a ramp-up period during which the signal 902 is in the process of being stabilized by the calibration circuit of FIG. 8. Starting at a beginning of the time period t1, Amplitude (e.g., a voltage along the Y-axis) of signal 902 may be increased by increasing the gain G of block 710. For example, the gain G may be increased to a maximum voltage denoted by a Max voltage along a ADC Input Range on the Y-axis. As a result, post calibration, an accuracy of the system for a specific user is increased. A beginning time period t2 depicts a signal level that appropriately may utilize the input resolution of the ADC. Post calibration, signal 902 may be regarded as having been "normalized" for a specific user based on specific user data. In an embodiment the foregoing process may be implemented using electronics located in the sensor (e.g., 104A-104C), in the controller 106 or both.

[1017] As may be appreciated from the foregoing description, embodiments and examples described herein may provide for a consumer-friendly system or platform for performing health-related and performance-related human monitoring, analyzing and feedback. By monitoring multiple muscles simultaneously and/or using multiple electromyography sensors and/or different types of sensors, and by leveraging technology widely adopted by consumers (e.g., the Internet, wireless interface, smart phones, etc.), the exercise data may be efficiently logged and the human subject may be given detailed and useful feedback and coaching pertaining not only to whether the muscle is being exercised, but also whether the right group of muscles are being exercised for a specific workout profile, whether a specific muscle is optimally exercised, whether the exercise form is correct, whether the pattern of muscle activation and/or intensity thereof indicates potential injury to one or more of the muscles in the relevant group, etc.

[1018] As may be appreciated from the foregoing description, embodiments and examples described herein may provide for a comprehensive and user-friendly textile-based human MAF system 100. By providing a plurality of sensors (e.g., 104A-104C or more) integrated on a compressive, form-fitting garment 102, problems associated with the aforementioned conventional gel-based and/or adhesive-based electrodes may be advantageously avoided. Since the sensors (e.g., 104A-104C or more) may monitor groups of muscles instead of an individual muscle, more sophisticated and useful analysis results (e.g., pertaining to form and injury monitoring) become possible. Calibration may help to improve data acquisition accuracy by taking into account different body types when acquiring data from the sensors (e.g., 104A-104C or more).

[1019] The use of different types of sensors together (e.g., a electromyography sensor, heart rate sensors, respiration sensor, accelerometer, magnetometer, and a bend-angle sensor) to monitor a human subject performance on a particular exer-

cise routine greatly improves the accuracy and richness of the performance data acquired as well as improving the type of analysis and/or recommendation/coaching that can be provided. Real-time feedback and/or real time equipment alteration based on analysis result may also help optimize the exercise session and/or help reduce injury. Wireless communications and/or wireless networking between sensors of the garment **102** and the controller **106** may allow for flexibility in positioning of sensors including but not limited to sensors **104A-104C** at application specific locations on the garment **102**, particularly in situations where use of hard connections (e.g., wiring or electrically conductive traces or the like) may not be advantageous or may risk failure modes due to broken, faulty, intermittent, opens, or shorts, etc., in the hard connections, for example. Moreover, sensors positioned on different garments **102** (e.g., separate garments such as a pair of pants and a shirt) worn by the same user may be wirelessly linked to one another and/or to one or more controllers **106**. Each of the separate garments **102** may have its own controller **106** or one or more of the garments may not have a controller **106** and sensors in those garments **106** wirelessly communicate with the controller **106** in another garment **102**. Controllers **106** dispersed among multiple garments **102** may wirelessly communicate with one another and/or with sensors in other garments. Processing, signal analysis and other controller **106** functions may be shared or otherwise distributed among multiple controllers **106**, or a single one of the controllers **106** may handle processing, signal analysis, and the other functions, etc. Wireless communications between external wireless devices and any of the sensors and/or controllers **106**, in a single garment **102**, or in multiple garments **102**, may be handled by one or more of the sensors, one or more of the controllers **102**, or both.

[0110] While the present application has been described in terms of several preferred embodiments and/or examples, there may be alterations, permutations, and equivalents, which fall within the scope of the present application. If the term “set” is employed herein, such term is intended to have its commonly understood mathematical meaning to cover zero, one, or more than one member. The present application should be understood to also encompass these alterations, permutations, and equivalents. It should also be noted that there are many alternative ways of implementing the systems, methods, computer readable media, and apparatuses of the present application. Although various examples are provided herein, it is intended that these examples be illustrative and not limiting with respect to the present application.

[0111] Although the foregoing examples have been described in some detail for purposes of clarity of understanding, the above-described concepts are not limited to the details provided. There are many alternative ways of implementing the above-described concepts for the present application. The disclosed embodiments and/or examples are illustrative and not restrictive.

What is claimed is:

1. An apparatus for monitoring, analyzing and providing feedback on physical activity of a user, comprising:

- a garment configured to be worn on a portion of a body of a human subject, the garment including,
- a controller,
- a plurality of electromyography (EMG) sensors configured to acquire bio-potential signals indicative of muscle activation,

- a battery pack electrically coupled with the controller, the EMG sensors or both,

- a fabric including an electrode base for each EMG sensor, the electrode base made from a conductive resin material and formed directly on the fabric, and
- conductive leads coupled with each electrode base and the controller, each conductive lead made from a flexible and electrically conductive material that is positioned on the fabric.

2. The apparatus of claim **1**, wherein the garment is configured to withstand a plurality of cycles of washing, drying or both, without damage to the garment, the controller, the plurality of EMG sensors, the electrode base, the conductive leads, or the battery pack.

3. The apparatus of claim **1**, wherein the plurality of EMG sensors are configured to sense the bio-potentials signals associated with a plurality of muscles of the human subject, and the fabric is configured to position the plurality of sensors in contact with the plurality of muscles when the garment is donned by the human subject.

4. The apparatus of claim **1**, wherein the fabric includes an alignment mark, a designed structure or both operative to aid the human subject in correct placement of the plurality of EMG sensors relative to muscles to be sensed by the plurality of EMG sensors when the human subject dons the garment.

5. The apparatus of claim **1** and further comprising:

- an equipment detector included with the garment and electrically coupled with the controller and the battery pack using another conductive lead made from a flexible and electrically conductive material that is directly formed on the fabric,

- the equipment detector including a first wireless communication link configured to wirelessly link with an exercise apparatus coupled with the human subject during muscle activation.

6. The apparatus of claim **1**, wherein the fabric is made from a stretchable, compressive and form-fitting material configured to bias the EMG sensors into contact with a plurality of muscles on the human subject when the human subject dons the garment.

7. The apparatus of claim **6**, wherein the material is selected from the group consisting of nylon, polyester, spandex, and synthetic fibers.

8. An apparatus for monitoring, analyzing and providing feedback on physical activity of a user, comprising:

- a garment configured to be worn on a portion of a body of a human subject, the garment including,

- a fabric,
- a controller,
- a sensor base made from a non-conductive resin material that is positioned on the fabric,

- a plurality of electromyography (EMG) sensors configured to acquire bio-potential signals indicative of muscle activation, the EMG sensors including an electrode base made from a conductive resin material that is positioned on the fabric,

- a battery pack electrically coupled with the controller, the EMG sensors or both, and

- conductive leads coupled with each electrode base and the controller, each conductive lead made from a flexible and electrically conductive material that is positioned on the fabric.

9. The apparatus of claim **8**, wherein the garment is configured to withstand a plurality of cycles of washing, drying or

both, without damage to the garment, the controller, the plurality of EMG sensors, the electrode base, the sensor base, the conductive leads, or the battery pack.

10. The apparatus of claim **8** and further comprising:

an equipment detector include with the garment and electrically coupled with the controller and battery pack using another conductive lead made from a flexible and electrically conductive material that is directly formed on the fabric,

the equipment detector including a first wireless communication link configured to wirelessly link with an apparatus coupled with the human subject during muscle activation.

11. The apparatus of claim **8**, wherein one or more of the plurality of electromyography (EMG) sensors, the controller, or both are permanently connected with the garment.

12. The apparatus of claim **8**, wherein one or more of the plurality of electromyography (EMG) sensors, the controller, or both are detachably connected with the garment.

13. The apparatus of claim **8**, wherein the non-conductive resin material, the conductive resin material, or both comprise a material selected from the group consisting of a neoprene-based material, a polymer material, a rubber material, a thermoplastic material, and a silicone-based material.

14. A textile-based human monitoring, analysis, and feedback (MAF) system, comprising:

a garment configured to be worn on a portion of a body of a human subject, the garment made from a fabric that includes integrally fabricated with the fabric

a controller,

a sensor base made from a non-conductive resin material that is positioned on a fabric,

a plurality of electromyography (EMG) sensors configured to acquire bio-potential signals indicative of muscle activation, the EMG sensors including in an electrode base made from a conductive resin material that is positioned on the fabric,

a multi-axis motion sensor configured to acquire signals indicative of motion of the human subject,

a battery pack electrically coupled with the controller, the EMG sensors or both, and

conductive leads configured to couple the multi-axis motion sensor and each electrode base with the controller, each conductive lead made from a flexible and electrically conductive material that is positioned on the fabric.

15. The system of claim **14**, wherein the multi-axis motion sensor comprises one or more sensors selected from the group consisting of an accelerometer, a plurality of accelerometers, a magnetometer, and a gyroscope.

16. The system of claim **14**, wherein each EMG sensor comprises two electrode sensing sites electrically coupled with a differential amplifier, the differential amplifier is configured to amplify a voltage difference between the bio-potential signals from the two electrode sensing sites, an output of the differential amplifier is coupled with an analog-to-digital-converter (ADC), and an output of the ADC is coupled with a signal processor.

17. The system of claim **14** and further comprising one or more sensors selected from the group consisting of a heart rate sensor, a respiration sensor, a temperature sensor, and a galvanic skin response sensor.

18. The system of claim **14**, wherein the conductive leads couple each EMG sensor with inputs of a calibration circuit.

19. The system of claim **18**, wherein the sensor electronics output a sensed signal (SS) indicative of muscle activity from the human subject and the SS is coupled with an input of a variable gain block configured to scale the SS by a gain factor set by a user profile signal that is coupled with an input node of the variable gain block, the input node coupled with the controller.

20. The system of claim **19**, wherein the user profile includes one or more user specific data selected the group consisting of a Body Mass Index (BMI), historical data, a body type, and a body fat percentage.

* * * * *

专利名称(译)	可穿戴的架构和性能监控，分析和反馈方法		
公开(公告)号	US20140135593A1	公开(公告)日	2014-05-15
申请号	US14/079629	申请日	2013-11-13
[标]申请(专利权)人(译)	jayalth dhananja 韦别克里斯托弗		
申请(专利权)人(译)	JAYALTH, DHANANJA WEIBE, CHRISTOPHER		
当前申请(专利权)人(译)	MAD服装, INC.		
[标]发明人	JAYALTH DHANANJA WEIBE CHRISTOPHER		
发明人	JAYALTH, DHANANJA WEIBE, CHRISTOPHER		
IPC分类号	A61B5/00 A61B5/0488		
CPC分类号	A61B5/0015 A61B5/6804 A61B5/0488 A61B5/0022 A61B5/02055 A61B5/04004 A61B5/0492 A61B5/6805 A61B2503/10 A61B2562/18 G09B19/0038 G16H40/67 A41D1/04 A41D2500/52 A61B5/0004 A61B5/0402 A61B5/1118 A61B5/6841 A61B2560/0223 A61B2562/0209 A63B2024/0009 A63B2024/0078		
优先权	61/726470 2012-11-14 US 61/726474 2012-11-14 US		
其他公开文献	US9498128		
外部链接	Espacenet USPTO		

摘要(译)

本申请一般涉及计算机软件，移动电子设备，无线通信链路和可穿戴监视系统。更具体地，描述了用于可穿戴监测设备和相关锻炼设备的技术，织物，材料，系统，传感器，EMG传感器，电路，算法和方法。例如，服装传感器系统可以生成关于用户在锻炼期间的表现的数据，并且可以实时分析数据并且可以基于该分析向用户提供反馈。一件锻炼设备可以被装备并与传感器系统或其他系统通信，并且可以实时控制以调整其设置以在锻炼例程期间影响用户。传感器系统和其他系统之间的通信可以是无线的。直接形成在衣服织物中的导电结构可以整体地包括传感器，电路，控制器，导电迹线和传感器电子器件。

