



US010441796B2

(12) **United States Patent**  
**Demmer et al.**

(10) **Patent No.: US 10,441,796 B2**  
(45) **Date of Patent: Oct. 15, 2019**

(54) **MULTI-CHAMBER INTRACARDIAC PACING SYSTEM**

(58) **Field of Classification Search**

CPC ..... A61N 1/37; A61N 1/362

USPC ..... 607/14, 18

See application file for complete search history.

(71) Applicant: **Medtronic, Inc.**, Minneapolis, MN (US)

(72) Inventors: **Wade M Demmer**, Coon Rapids, MN (US); **Todd J Sheldon**, North Oaks, MN (US); **Saul E Greenhut**, Aurora, CO (US); **James D Reinke**, Maple Grove, MN (US)

(56) **References Cited**

U.S. PATENT DOCUMENTS

5,113,859 A 5/1992 Funke  
5,507,782 A 5/1996 Kieval  
5,683,432 A 11/1997 Goedeke  
6,477,415 B1 11/2002 Yerich  
6,772,005 B2 8/2004 Casavant  
(Continued)

(73) Assignee: **Medtronic, Inc.**, Minneapolis, MN (US)

(\* ) Notice: Subject to any disclaimer, the term of this patent is extended or adjusted under 35 U.S.C. 154(b) by 422 days.

FOREIGN PATENT DOCUMENTS

WO 2016010976 A1 1/2016

(21) Appl. No.: **14/644,878**

OTHER PUBLICATIONS

(22) Filed: **Mar. 11, 2015**

(PCT/US2016/019889) PCT Notification of Transmittal of the International Search Report and the Written Opinion of the International Searching Authority, dated Jul. 25, 2016, 13 pages.

(65) **Prior Publication Data**

US 2016/0015984 A1 Jan. 21, 2016

Primary Examiner — Jon Eric C Morales

(51) **Int. Cl.**

**A61N 1/37** (2006.01)  
**A61N 1/362** (2006.01)  
**A61N 1/365** (2006.01)  
**A61N 1/375** (2006.01)  
**A61N 1/36** (2006.01)  
**A61B 5/00** (2006.01)  
**A61B 5/0464** (2006.01)  
**A61N 1/372** (2006.01)  
**A61B 5/0402** (2006.01)

(57) **ABSTRACT**

The control module of a first pacemaker included in an implantable medical device system including the first pacemaker and a second pacemaker is configured to set a pacing escape interval in response to a far field pacing pulse sensed by the first pacemaker. The far field pacing pulse is a pacing pulse delivered by the second pacemaker. The pacing escape interval is allowed to continue without restarting the in response to a far field intrinsic event sensed by the first pacemaker during the pacing escape interval. The first pacemaker delivers a cardiac pacing pulse to the heart upon expiration of the pacing escape interval.

(52) **U.S. Cl.**

CPC ..... **A61N 1/3706** (2013.01); **A61B 5/0464** (2013.01); **A61B 5/686** (2013.01); **A61N 1/36** (2013.01); **A61N 1/3622** (2013.01); **A61N 1/36592** (2013.01); **A61N 1/3756** (2013.01); **A61B 5/0402** (2013.01); **A61N 1/37205** (2013.01)

**21 Claims, 9 Drawing Sheets**

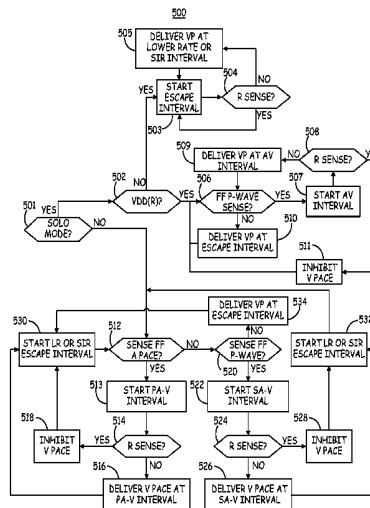

(56)

**References Cited**

## U.S. PATENT DOCUMENTS

7,031,772	B2	4/2006	Condie	
7,149,577	B2	12/2006	Sharma	
7,218,965	B2	5/2007	Casavant	
7,248,924	B2	7/2007	Casavant	
7,515,960	B2	4/2009	Sharma	
7,623,911	B2	11/2009	Sarkar	
7,689,279	B2	3/2010	Ziegler	
7,742,812	B2	6/2010	Ghanem	
7,869,876	B2	1/2011	Prakash	
8,170,666	B2	5/2012	Sheldon	
8,401,629	B2	3/2013	Stadler	
8,433,409	B2	4/2013	Johnson	
8,532,785	B1	9/2013	Crutchfield et al.	
8,541,131	B2	9/2013	Lund	
8,744,572	B1*	6/2014	Greenhut .....	A61N 1/37288 607/4
8,798,745	B2	8/2014	Jacobson	
9,278,226	B2	3/2016	Olson	
9,814,887	B2	11/2017	Nikolski et al.	
2008/0086185	A1	4/2008	Amurthur et al.	
2008/0114408	A1	5/2008	Shuros et al.	
2012/0172892	A1	7/2012	Grubac	
2013/0035748	A1	2/2013	Bonner	
2013/0138006	A1	5/2013	Bomzin et al.	
2013/0325081	A1	12/2013	Karst et al.	
2014/0100633	A1	4/2014	Mann et al.	
2014/0121720	A1	5/2014	Bonner et al.	
2015/0305642	A1	10/2015	Reinke et al.	
2016/0015322	A1	1/2016	Anderson et al.	
2016/0015985	A1*	1/2016	Cho .....	A61N 1/3706 607/14

\* cited by examiner

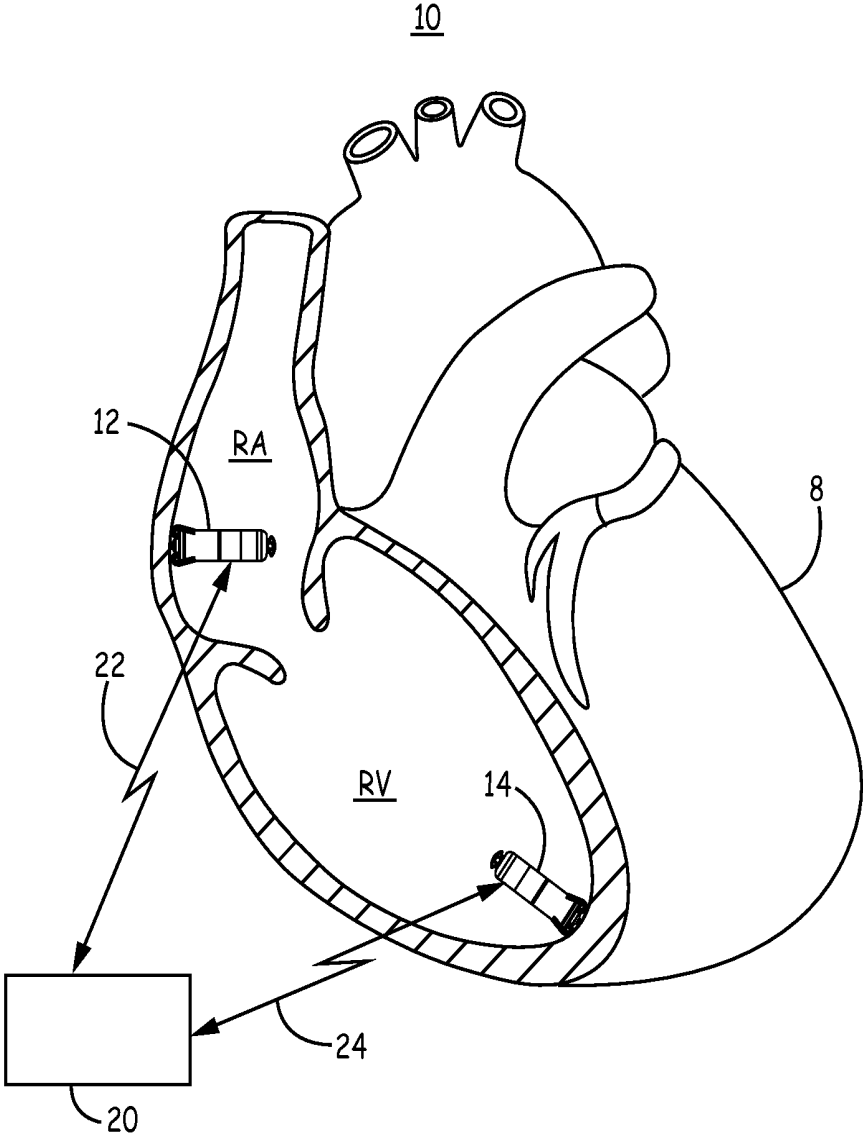
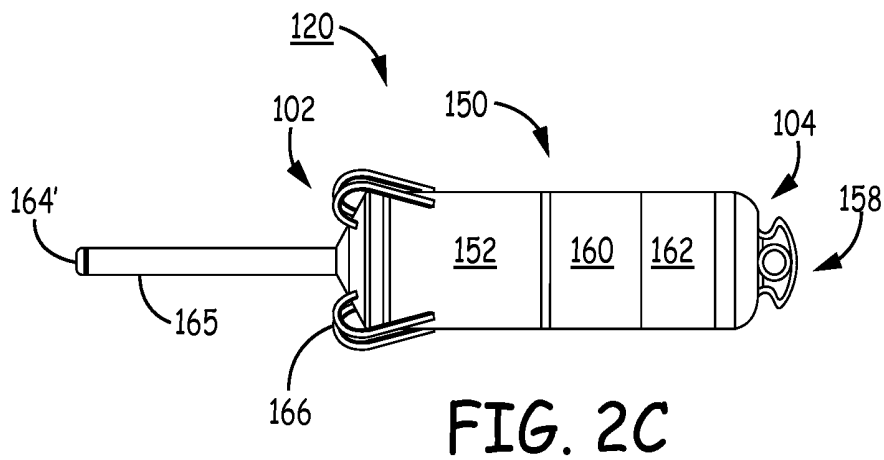
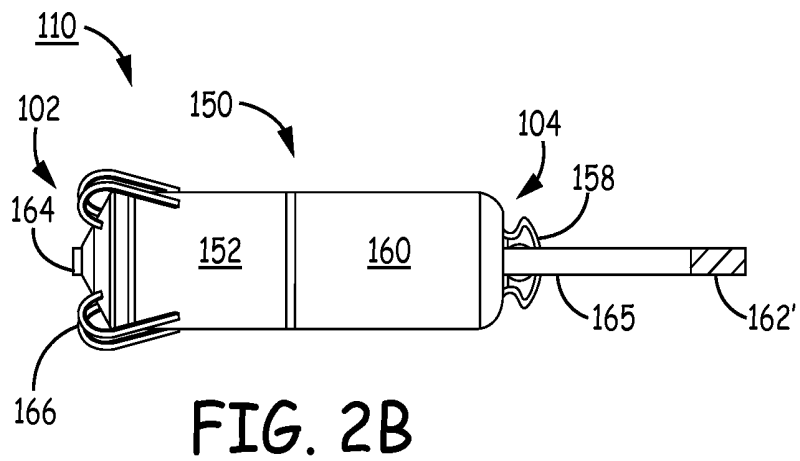
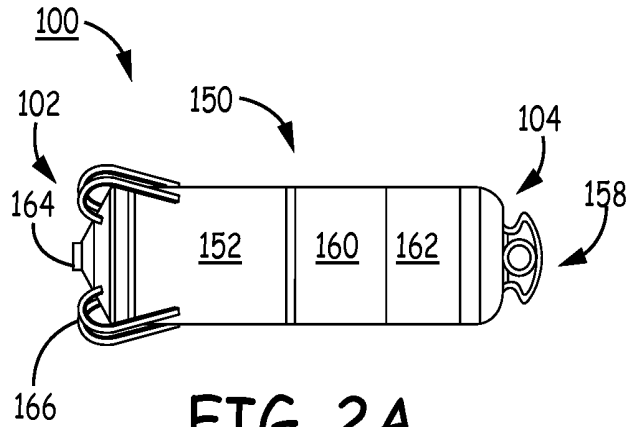

FIG. 1



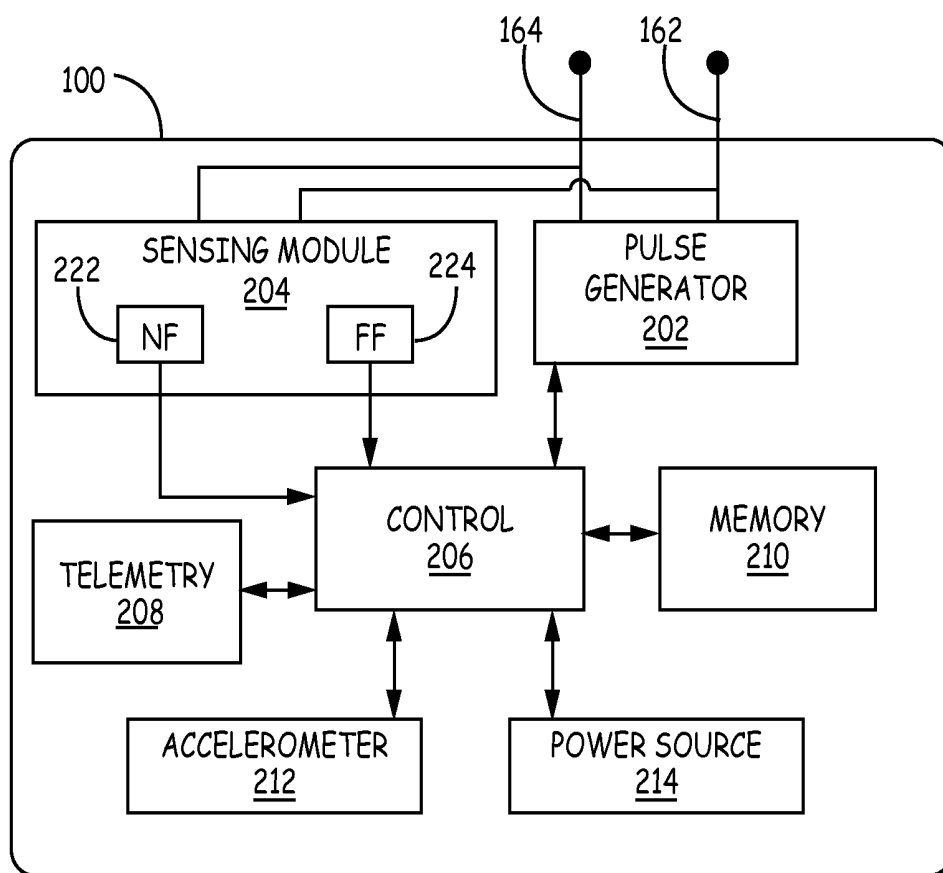

FIG. 3

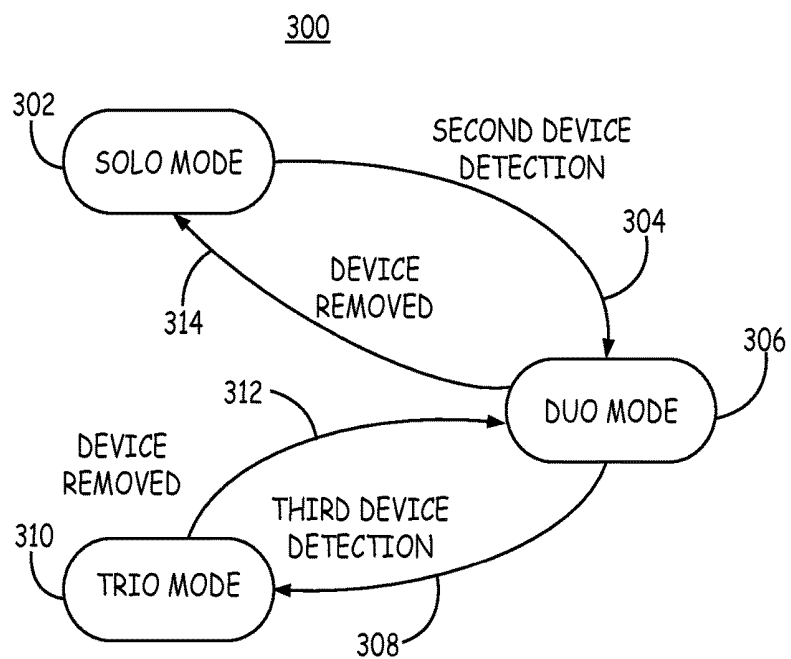

FIG. 4

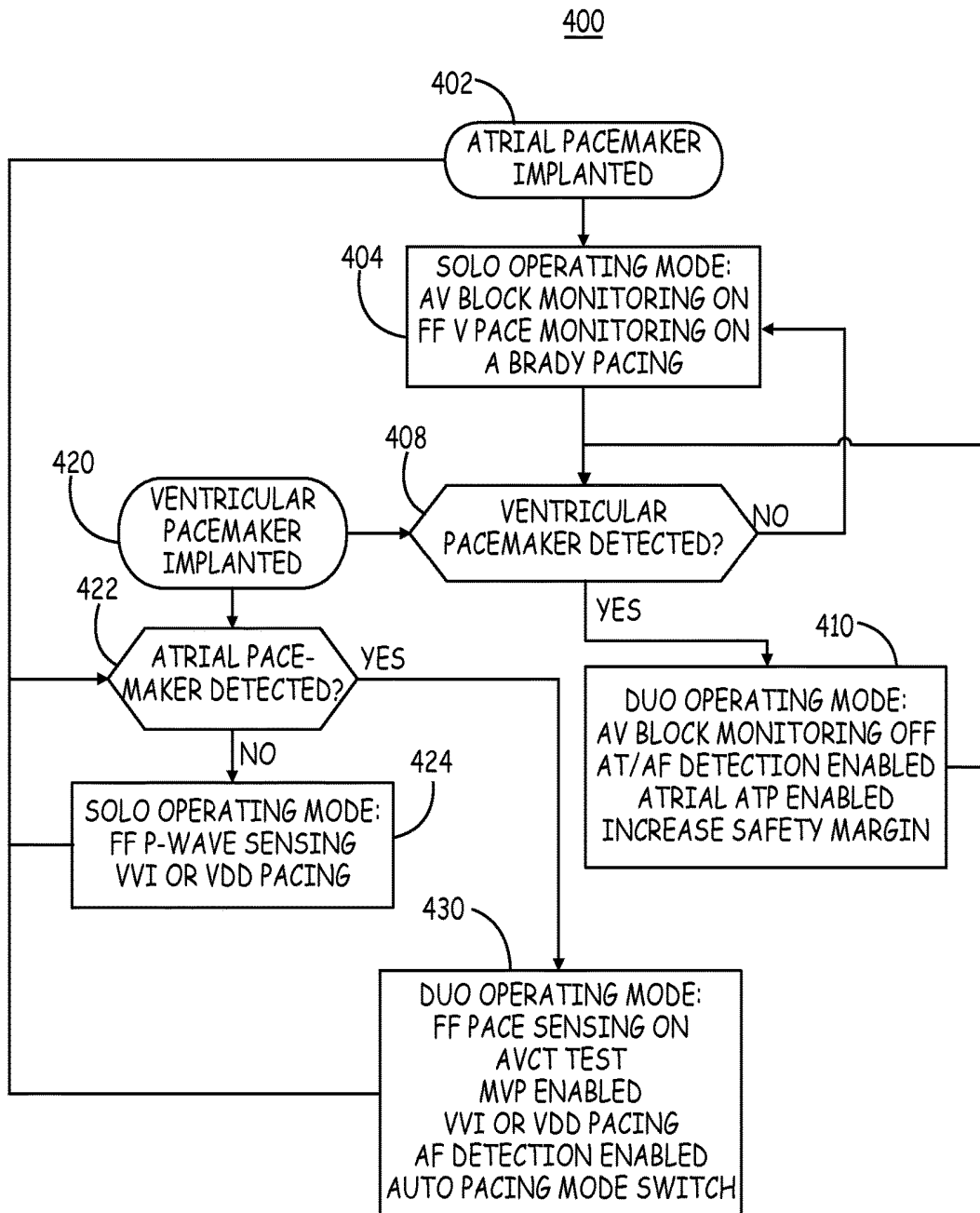

FIG. 5

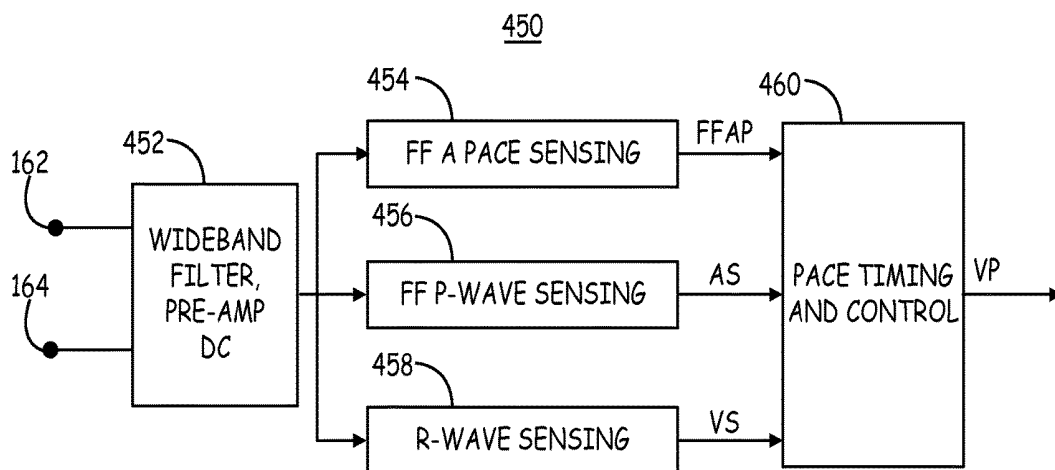

FIG. 6

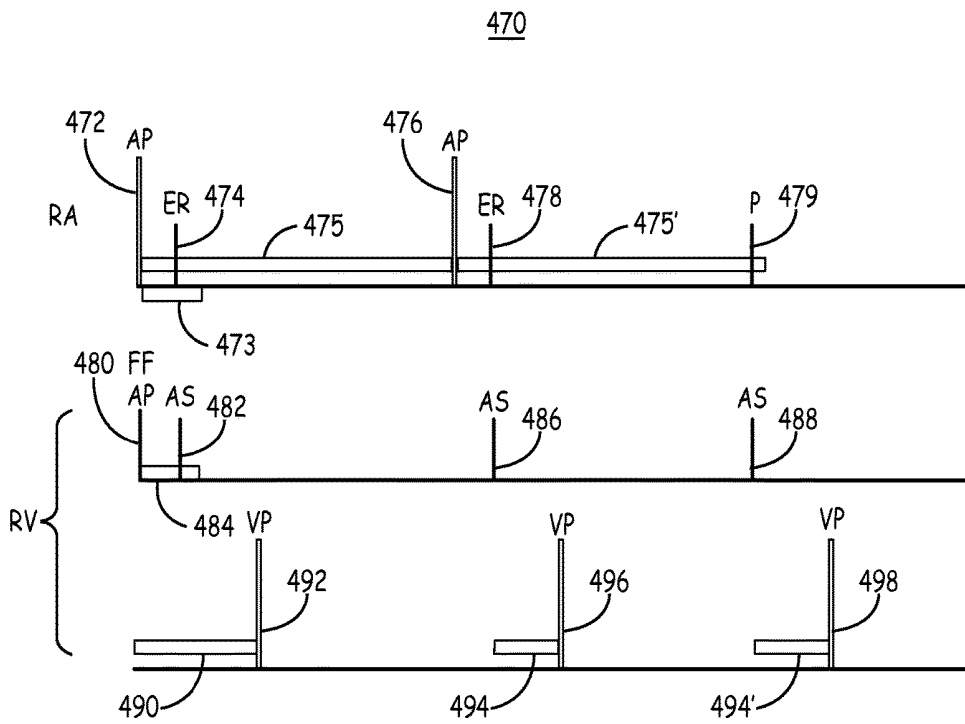

FIG. 7



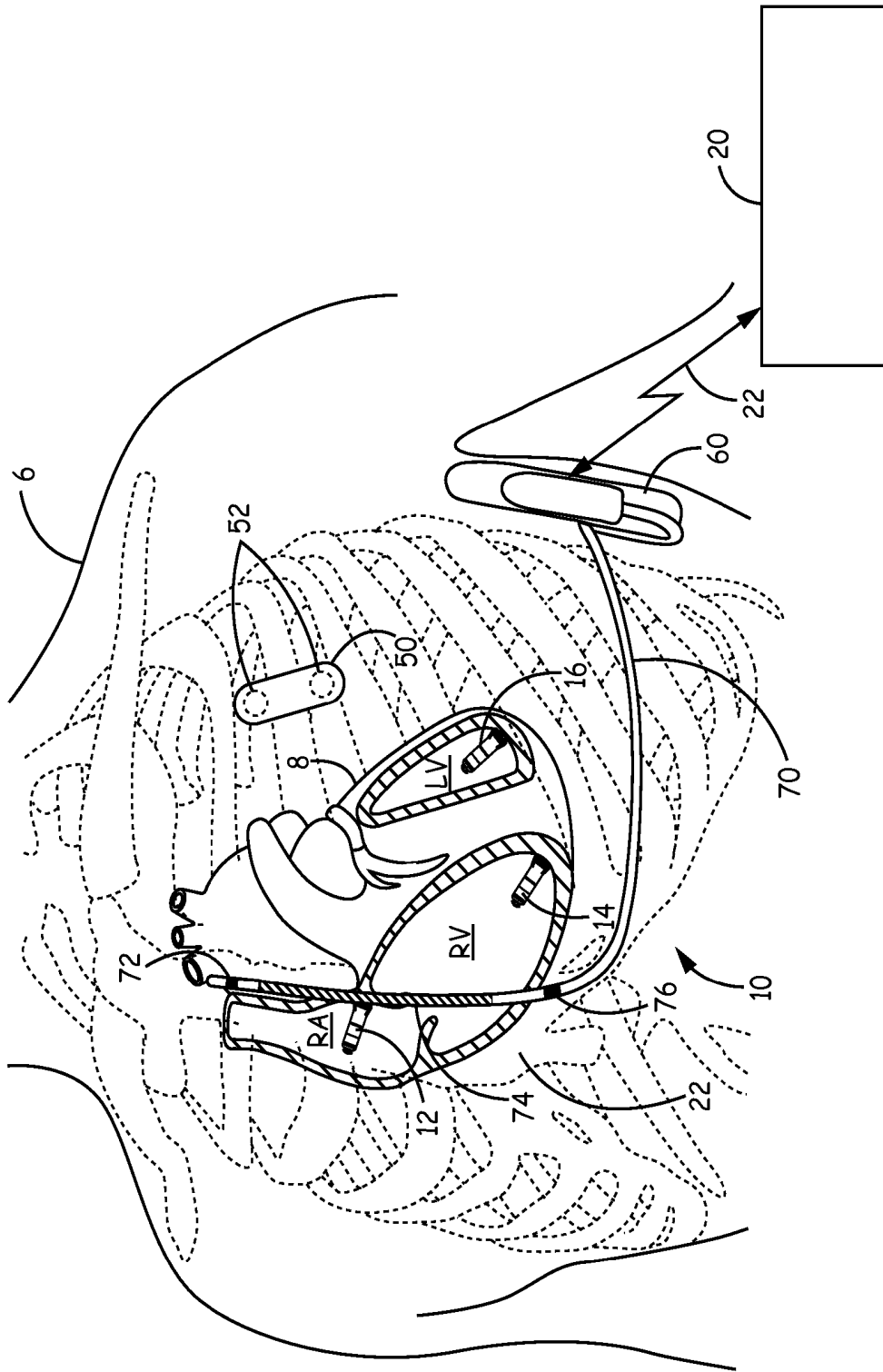

FIG. 9

## MULTI-CHAMBER INTRACARDIAC PACING SYSTEM

### TECHNICAL FIELD

The disclosure relates to an implantable medical device system and associated method for controlling the monitoring and therapy delivery functions of an intracardiac pacing device.

### BACKGROUND

Implantable cardiac pacemakers are commonly placed in a subcutaneous pocket and coupled to one or more transvenous medical electrical leads carrying pacing and sensing electrodes positioned in the heart. A cardiac pacemaker implanted subcutaneously may be a single chamber pacemaker coupled to one medical lead for positioning electrodes in one heart chamber, atrial or ventricular, or a dual chamber pacemaker coupled to two leads for positioning electrodes in both an atrial and a ventricular chamber. Multi-chamber pacemakers are also available that may be coupled to three leads for positioning electrodes for pacing and sensing in one atrial chamber and both the right and left ventricles.

The pacing mode of a pacemaker is commonly designated by a three- or four-letter code. The first letter may be an "A" for atrial, "V" for ventricular or "D" for dual (atrial and ventricular) to indicate which chamber(s) are paced. The second letter indicates which chamber(s) are sensed again designated by an "A," "V," or "D." The third letter indicates how the pacemaker responds when it senses a cardiac event. For example, a sensed cardiac event may trigger a pacing pulse and is indicated by a letter "T" or a sensed cardiac event may inhibit a pacing pulse and is indicated by a letter "I." In some cases, sensed cardiac events may both trigger and inhibit a pacing pulse depending on which chamber the event was sensed in. This dual response is indicated by the third letter "D."

By this convention, an AAI pacing mode delivers pacing pulses in an atrial chamber, senses atrial P-waves attendant to atrial depolarization in the atrium, and inhibits the atrial pacing pulse when a P-wave is sensed. A VVI pacing mode delivers pacing pulses in a ventricular chamber, senses ventricular R-waves attendant to ventricular depolarization and inhibits the ventricular pacing pulse when the R-wave is sensed.

One pacing mode is a DDD mode, which includes dual chamber pacing in both an atrial and ventricular chamber, dual chamber sensing in both an atrial and ventricular chamber, and a dual response to sensed events. For example, a sensed P-wave may trigger a ventricular pacing pulse at a programmed atrioventricular (AV) interval (atrial-triggered ventricular pacing), but a sensed R-wave during the AV interval inhibits the ventricular pacing pulse. Available dual chamber pacemakers that are capable of performing DDD pacing are implanted in a subcutaneous pocket and coupled to a transvenous atrial lead and a transvenous ventricular lead carrying atrial pacing and sensing electrodes and ventricular pacing and sensing electrodes, respectively, to enable the dual chamber pacemaker to sense and pace in both chambers.

A fourth letter, R, may be used to designate a rate responsive pacing mode of the pacemaker. In rate responsive pacing, the pacing rate is automatically adjusted in response to a sensor that indicates the metabolic need of the patient, such as a patient activity sensor. An AAIR, VVIR, or DDDR

pacing mode is configured to provide rate responsive pacing in the indicated heart chamber(s) by automatically adjusting the pacing lower rate according to a sensor signal indicating the patient's metabolic need.

### SUMMARY

In general, the disclosure is directed to implantable medical device (IMD) systems that includes at least two implantable pacemakers. At least one pacemaker operating in accordance with the techniques disclosed herein senses far field pacing pulses delivered by the other pacemaker and sets a pacing escape interval in response to sensing the far field pacing pulse.

In one example, the disclosure provides a medical device system comprising a first implantable pacemaker and a second implantable pacemaker. The first implantable pacemaker includes a sensing module configured to receive a cardiac electrical signal via a pair of electrodes. The sensing module is configured to sense near field intrinsic cardiac events occurring in a first heart chamber, far field intrinsic events occurring in a second heart chamber different than the first heart chamber, and far field pacing pulses from the cardiac electrical signal. The far field pacing pulses sensed by the sensing module are pacing pulses delivered in the second heart chamber by the second pacemaker. The first implantable pacemaker further includes a control module configured to set a first pacing escape interval in response to a far field pacing pulse sensed by the sensing module, allow the pacing escape interval to continue without restarting the pacing escape interval in response to a far field intrinsic event sensed by the sensing module during the pacing escape interval, and control a pulse generator to deliver a cardiac pacing pulse to the first heart chamber upon expiration of the first pacing escape interval.

In another example, the disclosure provides a method performed by an implantable medical device system including a first implantable pacemaker and a second implantable pacemaker. The method includes sensing from a cardiac electrical signal, received by a sensing module of the first implantable pacemaker, near field intrinsic cardiac events occurring in a first heart chamber, far field intrinsic events occurring in a second heart chamber different than the first heart chamber, and far field pacing pulses. The far field pacing pulses are pacing pulses delivered in the second heart chamber by the second pacemaker. The method further includes setting a pacing escape interval in response to a far field pacing pulse sensed by the sensing module, allowing the pacing escape interval to continue without restarting the pacing escape interval in response to a far field intrinsic event sensed by the sensing module during the pacing escape interval, and controlling a pulse generator to deliver a cardiac pacing pulse to the first heart chamber upon expiration of the first pacing escape interval.

In yet another example, the disclosure provides a non-transitory, computer-readable storage medium storing a set of instructions that when executed by a control module a control module of a first pacemaker of an implantable medical device system including the first pacemaker and a second pacemaker, cause the system to sense from a cardiac electrical signal, received by a sensing module of the first pacemaker, near field intrinsic cardiac events occurring in a first heart chamber, far field intrinsic events occurring in a second heart chamber different than the first heart chamber, and far field pacing pulses. The far field pacing pulses are pacing pulses delivered in the second heart chamber by the second pacemaker. The instructions, when executed by the

control module, further cause the system to set a pacing escape interval in response to a far field pacing pulse sensed by the sensing module, allow the pacing escape interval to continue without restarting the pacing escape interval in response to a far field intrinsic event sensed by the sensing module during the first pacing escape interval, and control a pulse generator of the first pacemaker to deliver a cardiac pacing pulse to the first heart chamber upon expiration of the first pacing escape interval.

This summary is intended to provide an overview of the subject matter described in this disclosure. It is not intended to provide an exclusive or exhaustive explanation of the apparatus and methods described in detail within the accompanying drawings and description below. Further details of one or more examples are set forth in the accompanying drawings and the description below.

### BRIEF DESCRIPTION OF DRAWINGS

FIG. 1 is a conceptual diagram illustrating an intracardiac pacing system that may be used to sense cardiac electrical signals and provide therapy to a patient's heart.

FIG. 2A is a conceptual diagram of an intracardiac pacemaker.

FIGS. 2B and 2C are conceptual diagrams of alternative embodiments of an intracardiac pacemaker.

FIG. 3 is a functional block diagram of an example configuration of the intracardiac pacemaker shown in FIG. 2A, 2B or 2C.

FIG. 4 is a conceptual diagram of self-configuring operating modes of an intracardiac pacemaker.

FIG. 5 is a flow chart of the operation of an intracardiac atrial pacemaker and an intracardiac ventricular pacemaker both enabled to automatically configure solo and duo operating modes according to the presence or absence of the other pacemaker.

FIG. 6 is a functional block diagram of sensing and pacing control modules included in an intracardiac pacemaker according to one example.

FIG. 7 is a timing diagram depicting the operation of right atrial and right ventricular intracardiac pacemakers when configured in duo operating modes.

FIG. 8 is a flow chart of a method for controlling ventricular pacing by an intracardiac ventricular pacemaker.

FIG. 9 is a conceptual diagram of another example of an IMD system including multiple, self-configuring intracardiac pacemakers and other extracardiac implantable medical devices.

### DETAILED DESCRIPTION

An implantable medical device (IMD) system is disclosed herein that includes self-configuring IMDs. In various examples, the IMD system includes self-configuring intracardiac pacemakers that do not require transvenous leads but are enabled to provide multi-chamber monitoring and/or therapy delivery functions, such as dual chamber DDD(R) pacing, in a coordinated manner via self-configuring operating modes.

An intracardiac pacemaker included in the system has a control module that self-configures the pacemaker operating mode in response to establishing the presence of other IMDs implanted in the patient in order to provide coordinated and efficient operation between the intracardiac pacemaker and one or more other implanted intracardiac pacemakers and/or other IMDs. When more than one intracardiac pacemaker is present, each pacemaker may self-configure its operating

mode to enable multi-chamber sensing and/or therapy delivery functions to be achieved by the separate intracardiac pacemakers in a coordinated manner.

A dual chamber pacemaker positioned in an implant pocket and coupled to transvenous atrial and ventricular leads may be programmed in an AAI(R), VVI(R) or DDD(R) mode according to patient need. The dual chamber pacemaker is able to control the delivery of pacing pulses in both atrial and ventricular chambers because the pacemaker will receive sensed event signals from both chambers and control when a pacing pulse is delivered in both chambers relative to sensed events using the electrodes positioned in both chambers. In other words, the dual chamber pacemaker knows when both sensed and paced events have occurred in both atrial and ventricular pacing channels since all sensing and pacing control is happening in the one device, i.e., the dual chamber pacemaker.

Intracardiac pacemakers have been introduced that are adapted to be implanted wholly within a heart chamber. Elimination of transvenous, intracardiac leads has several advantages. For example, complications due to infection associated with a lead extending from a subcutaneous pacemaker pocket transvenously into the heart can be eliminated. Other complications such as "Twiddler's syndrome", lead fracture or poor connection of the lead to the pacemaker are eliminated in the use of an intracardiac pacemaker.

An intracardiac pacemaker can operate in a single chamber mode, e.g., AAI or VVI, by delivering pacing pulses and inhibiting pacing when an intrinsic event is sensed in the chamber that the pacemaker is implanted in. While some patients may require only single chamber pacing and sensing, patients having AV conduction defects may require a pacing system capable of a DDD pacing mode to provide atrial-synchronized ventricular pacing. As disclosed herein, an IMD system includes intracardiac pacemakers that are configured to establish whether another IMD is present in the patient's body and self-configure its own operating mode from multiple self-configuring operating modes based on the presence or absence of the other IMD(s). When two or more intracardiac pacemakers are present, the ability to configure an operating mode that coordinates the operation of one pacemaker with the operation of the other pacemaker enables the two pacemakers to perform multi-chamber monitoring and therapy delivery operations, e.g., DDD pacing, in an effective and efficient manner.

FIG. 1 is a conceptual diagram illustrating an intracardiac pacing system 10 that may be used to sense cardiac electrical signals and provide therapy to a patient's heart 8. IMD system 10 includes a right atrial (RA) intracardiac pacemaker 12 and a right ventricular (RV) intracardiac pacemaker 14. Pacemakers 12 and 14 are shown as transcatheter intracardiac pacemakers adapted for implantation wholly within a heart chamber, e.g., wholly within the RV, wholly within the left ventricle (LV), wholly within the RA or wholly within the left atrium (LA) of heart 8. In the example of FIG. 1, pacemaker 12 is positioned along an endocardial wall of the RA, e.g., along the RA lateral wall or RA septum. Pacemaker 14 is positioned along an endocardial wall of the RV, e.g., near the RV apex. The techniques disclosed herein, however, are not limited to the pacemaker locations shown in the example of FIG. 1 and other positions and relative locations from each other are possible.

Pacemakers 12 and 14 are reduced in size and generally cylindrical in shape to enable transvenous implantation via a delivery catheter. In other examples, pacemakers 12 and 14 may be positioned at any other location inside or outside heart 8, including epicardial locations. For example, pace-

maker **12** may be positioned outside or within the right atrium or left atrium to provide respective right atrial or left atrial pacing. Pacemaker **14** may be positioned outside or within the right ventricle or left ventricle to provide respective right ventricular or left ventricular pacing.

Pacemakers **12** and **14** are each capable of producing electrical stimulation pulses, i.e., pacing pulses, delivered to heart **8** via one or more electrodes on the outer housing of the pacemaker. RA pacemaker **12** is configured to sense an intracardiac electrogram (EGM) signal in the RA using the housing based electrodes and deliver RA pacing pulses. RV pacemaker **14** is configured to sense an EGM signal in the RV using one or more housing based electrodes and deliver RV pacing pulses.

Depending on individual patient need, RA pacemaker **12** may be implanted first, and RV pacemaker **14** may be implanted at a later time after the patient develops a need for ventricular pacing, e.g., if the patient develops AV conduction defects. In other examples, the patient may receive the RV pacemaker **14** first and later receive RA pacemaker **12**, or the patient may receive both RA pacemaker **12** and RV pacemaker **14** during the same implant procedure.

The RA pacemaker **12** and the RV pacemaker **14** are configured to detect the presence (or absence) of the other pacemaker and automatically select a solo operating mode or a duo operating mode based on whether the other pacemaker is present or not. Each of the RA pacemaker **12** and RV pacemaker **14** include a control module that controls functions performed by the respective pacemaker. The control module is enabled to self-configure the solo or duo operating mode in response to the presence or absence of the other pacemaker.

As will be described in greater detail below, each pacemaker **12** and **14** includes features and capabilities that are enabled or disabled automatically when an operating mode is self-configured. In some cases, the operating mode is adjusted automatically by the pacemaker control module based on the presence or absence of other types of implanted medical devices, such as an implantable cardioverter defibrillator (ICD), implantable ECG monitor, or other cardiac monitoring or therapy delivery device.

Pacemaker **12** and **14** are each capable of bidirectional wireless communication with an external device **20**. External device **20** may be a programmer used by a clinician or other user in a medical facility, a home monitor located in a patient's home, or a handheld device. Aspects of external device **20** may generally correspond to the external programming/monitoring unit disclosed in U.S. Pat. No. 5,507,782 (Kieval, et al.), hereby incorporated herein by reference in its entirety.

External device **20** establishes a wireless radio frequency (RF) communication link **22** with RA pacemaker **12** and wireless RF communication link **24** with RV pacemaker **14** using a communication protocol that appropriately addresses the targeted pacemaker **12** and **14**. An example RF telemetry communication system that may be implemented in system **10** is generally disclosed in U.S. Pat. No. 5,683,432 (Goedeke, et al.), incorporated herein by reference in its entirety.

External device **20** may be used for retrieving data from pacemakers **12** and **14** and for sending data to pacemakers **12** and **14**. Examples of retrieved data include physiological signals such as RA or RV EGM signals, therapy delivery data such as a history of pacing frequency, results of device diagnostic testing, current operating mode and control parameters or other data stored by the pacemaker.

Data sent to pacemakers **12** and **14** may include programmable control parameters. The self-configuring control module may establish which programmable control parameters and corresponding settings are available for a user to program based on the selected operating mode. The pacemaker **12** or **14** may transmit operating mode data to external device **20**, e.g., in response to an interrogation command from external device **20**, such that external device **20** displays user programmable parameters and settings relevant to the operating mode.

Pacemaker **12** and pacemaker **14** may or may not be configured to communicate directly with each other. For example, neither RA pacemaker **12** nor RV pacemaker **14** may be configured to initiate an RF communication session with the other device. Both pacemakers **12**, **14** may be configured to periodically "listen" for a valid "wake up" telemetry signal from external device **20** and power up its own telemetry module to establish a communication link **22** or **24** in response to a valid telemetry signal (or go back to "sleep" if no valid telemetry signal is received). However, pacemakers **12** and **14** may not be configured to transmit a "wake up" signal to the other pacemaker to initiate a communication session. In other examples, the pacemakers **12** and **14** may be configured to communicate with each other, but in order to conserve battery life of the intracardiac pacemakers, communication may be minimized. As such, communication may not occur on a beat-by-beat basis between the RA pacemaker **12** and RV pacemaker **14** for communicating when the other pacemaker is sensing cardiac events or when it is delivering pacing pulses.

A subcutaneously implanted dual chamber pacemaker is generally coupled to transvenous leads carrying electrodes positioned in both the RA and the RV. When a pacemaker is coupled to electrodes positioned in both chambers, P-wave sense signals and R-wave sense signals are available to control both atrial and ventricular pacing pulses in a coordinated manner with the sensed events. In system **10** of FIG. **1**, RA pacemaker **12** and RV pacemaker **14** may not be enabled to communicate by wireless RF telemetry on a beat-by-beat basis. The pacemaker in one heart chamber (RA or RV) does not receive communication signals transmitted directly from the other pacemaker in the other heart chamber indicating when the other pacemaker has sensed a cardiac event or when it has delivered a pacing pulse. In accordance with techniques disclosed herein, however, RV pacemaker **14** may be configured to sense far-field (FF) P-waves and FF atrial pacing pulses from the RV EGM signal. RV pacemaker **14** may therefore be enabled to indirectly determine when RA pacemaker **12** delivers a pacing pulse and/or when RA pacemaker **12** has most likely sensed a P-wave. Likewise, RA pacemaker **12** may be configured to sense FF ventricular events, including R-waves and/or ventricular pacing pulses.

As will be described herein, in a duo operating mode, the two pacemakers **12** and **14** may be configured to determine if a pacing pulse has been delivered by the other pacemaker and/or when an evoked or intrinsic event has been sensed by the other pacemaker such that the two individual pacemakers **12** and **14** can operate in a coherent, coordinated manner for delivering dual chamber pacing. In this way, a DDD(R) pacing mode is achieved by the operation of the two separate intracardiac pacemakers **12** and **14** without requiring direct communication, e.g., wired signals or wireless RF communication signals, between the two pacemakers **12** and **14** on a beat-by-beat basis.

The control module of at least a first one of the two pacemakers **12** and **14** is configured to determine when the

second pacemaker is sensing an event and/or delivering a pacing pulse based on sensed event signals produced by a sensing module of the first pacemaker. In addition to coordinating dual chamber pacing, the self-configured operating mode sets the status of other pacemaker functions as being enabled, disabled or otherwise adjusted based on the presence or absence of the other pacemaker, or another implanted device.

FIG. 2A is a conceptual diagram of an intracardiac pacemaker 100 that may correspond to RA pacemaker 12 or RV pacemaker 14 shown in FIG. 1. Pacemaker 100 includes electrodes 162 and 164 spaced apart along the housing 150 of pacemaker 100 for sensing cardiac EGM signals and delivering pacing pulses. Electrode 164 is shown as a tip electrode extending from a distal end 102 of pacemaker 100, and electrode 162 is shown as a ring electrode along a mid-portion of housing 150, for example adjacent proximal end 104. Distal end 102 is referred to as “distal” in that it is expected to be the leading end as it advanced through a delivery tool such as a catheter and placed against a target pacing site.

Electrodes 162 and 164 may be positioned on or as near as possible to respective proximal and distal ends 104 and 102 to increase the inter-electrode spacing between electrodes 162 and 164. Electrodes 162 and 164 form an anode and cathode pair for bipolar cardiac pacing and sensing. Relatively greater inter-electrode spacing will increase the likelihood of sensing FF signals that are used by the pacemaker 100 for detecting the presence of another pacemaker in another heart chamber and/or in coordinating pacing pulse delivery with a paced or sensed event in another heart chamber. For example, an increased inter-electrode spacing between electrodes 162 and 164 when pacemaker 100 is used as an RV pacemaker will improve the likelihood of reliably sensing FF P-waves.

In alternative embodiments, pacemaker 100 may include two or more ring electrodes, two tip electrodes, and/or other types of electrodes exposed along pacemaker housing 150 for delivering electrical stimulation to heart 8 and sensing EGM signals. Electrodes 162 and 164 may be, without limitation, titanium, platinum, iridium or alloys thereof and may include a low polarizing coating, such as titanium nitride, iridium oxide, ruthenium oxide, platinum black among others. Electrodes 162 and 164 may be positioned at locations along pacemaker 100 other than the locations shown.

Housing 150 is formed from a biocompatible material, such as a stainless steel or titanium alloy. In some examples, the housing 150 may include an insulating coating. Examples of insulating coatings include parylene, urethane, PEEK, or polyimide among others. The entirety of the housing 150 may be insulated, but only electrodes 162 and 164 uninsulated. In other examples, the entirety of the housing 150 may function as an electrode instead of providing a localized electrode such as electrode 162.

The housing 150 includes a control electronics subassembly 152, which houses the electronics for sensing cardiac signals, producing pacing pulses and controlling therapy delivery and other functions of pacemaker 100. Housing 150 further includes a battery subassembly 160, which provides power to the control electronics subassembly 152. Battery subassembly 160 may include features of the batteries disclosed in commonly-assigned U.S. Pat. No. 8,433,409 (Johnson, et al.) and U.S. Pat. No. 8,541,131 (Lund, et al.), both of which are hereby incorporated by reference herein in their entirety.

Pacemaker 100 may include a set of fixation tines 166 to secure pacemaker 100 to patient tissue, e.g., by interacting with the ventricular trabeculae. Fixation tines 166 are configured to anchor pacemaker 100 to position electrode 164 in operative proximity to a targeted tissue for delivering therapeutic electrical stimulation pulses. Numerous types of active and/or passive fixation members may be employed for anchoring or stabilizing pacemaker 100 in an implant position.

Pacemaker 100 may include a set of active fixation tines as disclosed in commonly-assigned, pre-grant publication U.S. 2012/0172892 (Grubac, et al.), hereby incorporated herein by reference in its entirety.

Pacemaker 100 may further include a delivery tool interface 158. Delivery tool interface 158 is located at the proximal end 104 of pacemaker 100 and is configured to connect to a delivery device, such as a catheter, used to position pacemaker 100 at an implant location during an implantation procedure, for example within a heart chamber.

A reduced size of pacemaker 100 enables implantation wholly within a heart chamber. In FIG. 1, RA pacemaker 12 and RV pacemaker 14 may have different dimensions. For example, RA pacemaker 12 may be smaller in volume than pacemaker 14, e.g., by reducing battery size, to accommodate implantation in the smaller heart chamber. As such, it is recognized that pacemaker 100 may be adapted in size, shape, electrode location or other physical characteristics according to the heart chamber in which it will be implanted.

FIG. 2B is a conceptual diagram of an alternative embodiment of an intracardiac pacemaker 110. Pacemaker 110 includes a housing 150, control assembly 152, battery assembly 160, fixation member 166 and electrode 164 along a distal end 102, and may include a delivery tool interface 158 along the proximal end 104 as described above in conjunction with FIG. 2A. Pacemaker 110 is shown to include an electrode 162' extending away from housing 150 along an extender 165. As such, instead of carrying a pair of electrodes along the housing 150, which limits the maximum possible inter-electrode spacing, an extender 165 may be coupled to the housing 150 for positioning an electrode 162' at an increased inter-electrode distance from distal tip electrode 164. Reference is made to U.S. Patent Application No. 62/025,690, filed provisionally on Jul. 17, 2014, incorporated herein by reference in its entirety, for examples of an intracardiac pacemaker having increased inter-electrode spacing between electrodes.

FIG. 2C is a conceptual diagram of an alternative embodiment of intracardiac pacemaker 120 having extender 165 coupled to the distal end 102 of pacemaker housing 150 to extend distal electrode 164' away from electrode 162 positioned along housing 150 near or at proximal end 104. Extender 165 shown in FIGS. 2B and 2C is an insulated electrical conductor that electrically couples electrode 162' (FIG. 2B) or electrode 164' (FIG. 2C) to pacemaker circuitry. Pacemaker 120 having an insulated, electrically conductive extender 165 for increasing the inter-electrode spacing may correspond generally to the implantable device and flexible conductor disclosed in commonly-assigned, pre-grant U.S. Publication No. 2013/0035748 (Bonner, et al.), hereby incorporated herein by reference in its entirety.

FIG. 3 is a functional block diagram of an example configuration of pacemaker 100 shown in FIG. 2A (or pacemakers 110 or 120 of FIGS. 2B and 2C), and may correspond generally to the functional circuitry included in both RA pacemaker 12 and RV pacemaker 14. Pacemaker

**100** includes a pulse generator **202**, a sensing module **204**, a control module **206**, memory **210**, telemetry module **208** and a power source **214**.

As used herein, the term “module” refers to an application specific integrated circuit (ASIC), an electronic circuit, a processor (shared, dedicated, or group) and memory that execute one or more software or firmware programs, a combinational logic circuit, or other suitable components that provide the described functionality. The particular form of software, hardware and/or firmware employed to implement the functionality disclosed herein will be determined primarily by the particular system architecture employed in the pacemaker. Providing software, hardware, and/or firmware to accomplish the described functionality in the context of any modern IMD, given the disclosure herein, is within the abilities of one of skill in the art.

Each of RA pacemaker **12** and RV pacemaker **14** may include similar modules as represented by the pacemaker **100** shown in FIG. **3**; however it is understood that the modules may be configured according to the functionality of the separate RA and RV pacemakers **12** and **14** as disclosed herein. For example, when pacemaker **100** is a RA pacemaker **12**, control module **206** is enabled to self-configure the solo and duo operating modes of the RA pacemaker as disclosed herein. Likewise, when pacemaker **100** is a RV pacemaker **14**, control module **206** is enabled to self-configure the solo and duo operating modes of the RV pacemaker as disclosed herein. Adaptations of the hardware, firmware or software of the various modules necessary to meet the described functionality of the intracardiac pacemakers positioned in different heart chambers as disclosed herein is understood to be included in the various modules.

The functions attributed to pacemaker **100** herein may be embodied as one or more processors, controllers, hardware, firmware, software, or any combination thereof. Depiction of different features as specific circuitry or modules is intended to highlight different functional aspects and does not necessarily imply that such functions must be realized by separate hardware or software components or by any particular architecture. Rather, functionality associated with one or more modules, processors, or circuits may be performed by separate hardware or software components, or integrated within common hardware or software components. For example, pacing control operations performed by pacemaker **100** may be implemented in control module **206** executing instructions stored in associated memory **210** and relying on input from sensing module **204**.

Pulse generator **202** generates electrical stimulation pulses that are delivered to heart tissue via electrodes **162** and **164**. Electrodes **162** and **164** may be housing-based electrodes as shown in FIG. **2A**, but one or both electrodes **162** and **164** may alternatively be carried by an insulated, electrical conductor extending away from the pacemaker housing as described in conjunction with FIGS. **2B** and **2C**.

Pulse generator **202** may include one or more capacitors and a charging circuit to charge the capacitor(s) to a programmed pacing pulse voltage. At appropriate times, as controlled by a pace timing and control circuit included in control module **206**, the capacitor is coupled to pacing electrodes **162** and **164** to discharge the capacitor voltage and thereby deliver the pacing pulse. Pacing circuitry generally disclosed in the above-incorporated U.S. Pat. No. 5,507,782 (Kieval, et al.) and in commonly assigned U.S. Pat. No. 8,532,785 (Crutchfield, et al.), incorporated herein by reference in its entirety, may be implemented in pacemaker **100** for charging a pacing capacitor to a predeter-

mined pacing pulse amplitude under the control of control module **206** and delivering a pacing pulse.

Control module **206** controls pulse generator **202** to deliver a pacing pulse in response to expiration of a pacing timing interval according to programmed therapy control parameters stored in memory **210**. Control module **206** self-configures an operating mode based on establishing whether another pacemaker is present or not. Within a given operating mode, one or more pacing modes may be available, each defined by an appropriate set of control parameters. The pace timing and control circuit included in control module **206** sets various timing intervals, often referred to as escape intervals, used for controlling the timing of pacing pulses relative to a paced or sensed event. Upon expiration of a pacing timing interval, a pacing pulse is delivered. If a cardiac event is sensed during the pacing timing interval, the scheduled pacing pulse may be inhibited, and the pacing timing interval may be restarted.

For example, RA pacemaker **12** (FIG. **1**) may operate by starting a lower rate pacing escape interval in response to an intrinsic sensed P-wave or an atrial pacing pulse. If the escape interval expires prior to sensing a next intrinsic P-wave, an atrial pacing pulse is delivered. If an intrinsic P-wave is sensed by sensing module **204**, the escape interval is restarted. Similarly, RV pacemaker **14** (FIG. **1**) may set a lower rate pacing escape interval in response to an intrinsic sensed R-wave or ventricular pacing pulse. If the escape interval expires, a ventricular pacing pulse is delivered by pulse generator **202**. If an R-wave is sensed during the escape interval, outside any applicable blanking or refractory intervals, the escape interval is restarted.

Sensing module **204** includes cardiac event detectors for receiving cardiac EGM signals developed across electrodes **162** and **164**. A cardiac event is sensed by sensing module **204** when the EGM signal crosses a sensing threshold, which may be an auto-adjusting sensing threshold, of a cardiac event detector. In response to a sensing threshold crossing, sensing module **204** passes a sensed event signal to control module **206**. RA pacemaker **12** may be programmed with a sensing threshold appropriate for sensing P-waves attendant to the depolarization of the atria. RV pacemaker **14** may be programmed with a sensing threshold appropriate for sensing R-waves attendant to the depolarization of the ventricles.

The terms “sensed cardiac events” or “sensed events” as used herein refers to events sensed by sensing module **204** in response to the EGM signal crossing a sensing threshold, which may be an amplitude threshold, a frequency threshold, a slew rate threshold, or any combination thereof. Sensed cardiac events may include intrinsic events and evoked events, both of which may also be referred to as “depolarization events” since both intrinsic and evoked sensed cardiac events are associated with depolarization of the myocardium, either an intrinsic depolarization or a pacing evoked depolarization of the myocardium, respectively. Intrinsic events are events arising in the heart in the absence of a pacing pulse. Intrinsic events include intrinsic P-waves, such as sinus P-waves originating from the sinoatrial node of the heart, and intrinsic R-waves, such as sinus R-waves conducted from the atria via the atrioventricular node. Intrinsic events can also include non-sinus intrinsic events, such as premature atrial contractions (PACs) or premature ventricular contractions (PVCs) that arise intrinsically from the heart but are ectopic in origin.

Sensed intrinsic events may include near-field (NF) events and far-field (FF) events. NF events are events that are occurring in the heart chamber where the bipolar sensing

electrodes **162** and **164** are positioned. FF events are events occurring in a different heart chamber, where electrodes **162** and **164** are not positioned. As described herein, pacemaker **100** may sense NF and FF events for monitoring the patient's heart and/or for controlling pacing pulse delivery. As such, sensing module **204** may include a NF sensing channel **222** for sensing NF events and providing NF sensed event signals to control module **206** and a FF sensing channel **224** for sensing FF events and providing FF sensed event signals to control module **206**.

For example, the RA pacemaker **12** may sense both NF P-waves and FF R-waves. A P-wave sensing threshold may be used by NF sensing channel **222**, and a different R-wave sensing threshold may be used by FF sensing channel **224** and applied to the same EGM signal received by electrodes **162** and **164** to distinctly sense NF P-waves and FF R-waves. The threshold may be applied to a signal amplitude or other waveform morphology features to differentiate NF and FF signals. Additionally or alternatively, different sensing windows, refractory windows, and/or blanking intervals may be applied by control module **206** to discriminate between NF P-waves and FF R-waves based on timing. For example, a refractory or blanking interval may be set by the RA pacemaker control module **206** following a P-wave sensed event signal or an atrial pacing pulse so that any event sensed during the refractory or blanking interval may be identified as a FF R-wave and is not used to reset a lower rate pacing escape interval and therefore ignored for determining the atrial intrinsic rate and for controlling atrial pacing. Alternatively, a sensed FF R-wave could also be used to set an escape interval for controlling the timing of the next atrial pacing pulse. The sensed FF R-wave may be used by the RA pacemaker for monitoring purposes, such as monitoring the AV conduction time between the atria and the ventricles.

Far-field P-waves may be present on the ventricular EGM signal sensed by RV pacemaker **14**. FF P-waves are typically much smaller in amplitude than NF R-waves and are therefore distinguishable from R-waves based on amplitude. An R-wave sensing threshold can be set greater than an expected FF P-wave amplitude so that R-waves are sensed when the EGM signal received by electrodes **162** and **164** crosses the R-wave sensing threshold in NF sensing channel **222**. FF P-waves may be sensed by FF sensing channel **224** of the RV pacemaker using a different sensing threshold than the NF R-wave sensing threshold, and optionally using a designated P-wave sensing window applied by control module **206**. FF P-wave sense signals received from FF sensing channel **224** may be used by control module **206** to deliver atrial-synchronized ventricular pacing as further described below and as generally disclosed in the above-incorporated U.S. Patent Application No. 62/025,690, filed provisionally on Jul. 17, 2014.

As indicated above, events sensed by sensing module **204** may include evoked events. An evoked event is the signal attendant to depolarization of the myocardial tissue caused by a pacing pulse. Evoked events may be sensed in order to verify capture of a pacing pulse. For example, the RA pacemaker **12** may be configured to deliver a RA pacing pulse, set a blanking interval during the pacing pulse to prevent saturation of the sensing module **202** due to the pacing pulse, then set a capture detection window. A P-wave sensed during the capture detection window is sensed as an evoked P-wave and is evidence that the pacing pulse successfully captured the atrium. The RA pacemaker **12** may sense both intrinsic P-waves and evoked P-waves. FF evoked R-waves caused by delivering of a ventricular pac-

ing pulse by RV pacemaker **14** may also be sensed by FF sensing channel **224**. FF evoked P-waves caused by an atrial pacing pulse delivered by RA pacemaker **12** may be sensed by the FF sensing channel **224** in RV pacemaker **14**.

Sensed events may further include sensing of a pacing pulse delivered by an intracardiac pacemaker in another heart chamber. For example, RA pacing pulses delivered by RA pacemaker **12** may have a relatively high amplitude on the ventricular EGM signal received by the sensing module **204** of RV pacemaker **14**. Similarly, a RV pacing pulse delivered by RV pacemaker **14** may appear as a FF signal on the RA EGM signal received by RA pacemaker **12**. Sensing module **204** may be configured to produce FF pacing pulse sense signals that are passed to control module **206** so that one pacemaker can identify the time that the other pacemaker in another heart chamber has delivered a pacing pulse.

For example, in RV pacemaker **14**, FF sensing channel **224** of sensing module **204** may be configured to sense FF atrial pacing pulses. As described in greater detail below, FF atrial pacing pulse sense signals provided to control module **206** are used to control the timing of ventricular pacing pulses during atrial-synchronized ventricular pacing. Depending on the frequency characteristics of the sensing module **204** and the relative orientation of the pacemakers **12** and **14**, and their respective electrodes, the RA pacing pulse may or may not be sensed by the RV sensing module **204**.

Sensing module **204** may include multiple sensing channels for intentionally sensing both NF and FF events, including NF and FF intrinsic events, NF and FF evoked events, and FF pacing pulse events. By intentionally sensing FF events, control module **206** can control pacemaker **100** to operate in a coordinated manner with a pacemaker in another heart chamber.

For example, RV pacemaker **14** may include a NF channel **222** for sensing NF R-waves and a FF channel **224** for sensing FF atrial pacing pulses delivered by RA pacemaker **12** and/or FF P-waves. The NF and FF sensing channels **222** and **224** may have different band pass frequencies and different sensing thresholds. FF sensing channel **224** may include one or more cardiac event detectors or "sub-channels" to separately sense different FF events, e.g., FF P-waves and FF atrial pacing pulses. The same EGM signal acquired across electrodes **162** and **164** is applied to all sensing channels, but different events are sensed based on the different bandpass frequencies and sensing thresholds selected to enhance sensing of a desired NF or FF event.

In response to a sensing threshold crossing, sensing module **204** passes sensed event signals to control module **206**. Sensed event signals may include FF pacing pulse sensed event signals, FF R-wave or P-wave sensed event signals (e.g., FF P-waves in the case of RV pacemaker **14** and FF R-waves in the case of RA pacemaker **12**), and NF R-wave or P-wave sensed event signals (NF R-waves in the case of RV pacemaker **14** and NF P-waves in the case of RA pacemaker **12**).

Control module **206** uses the sensed event signals to control pulse generator **202** in a desired pacing mode as described in greater detail below. Additionally or alternatively, FF pacing pulse sensed event signals may be used by control module **206** to establish the presence of an intracardiac pacemaker in another heart chamber.

Memory **210** may include computer-readable instructions that, when executed by control module **206**, cause control module **206** to perform various functions attributed throughout this disclosure to pacemaker **100**. The computer-read-

able instructions may be encoded within memory **210**. Memory **210** may include any non-transitory, computer-readable storage media including any volatile, non-volatile, magnetic, optical, or electrical media, such as a random access memory (RAM), read-only memory (ROM), non-volatile RAM (NVRAM), electrically-erasable programmable ROM (EEPROM), flash memory, or other digital media with the sole exception being a transitory propagating signal. Memory **210** stores timing intervals, counters, or other data used by control module **206** to control the delivery of pacing pulses by pulse generator **202** according to the currently configured operating mode.

Pacemaker **100** may further include an accelerometer **212** for producing a patient activity signal passed to control module **206**. Accelerometer **212** may be embodied as a piezoelectric crystal for producing a signal correlated to body motion. The use of an accelerometer in an intracardiac device for obtaining a patient activity signal is generally disclosed in U.S. patent application Ser. No. 14/174,514 filed on Feb. 6, 2014 (Nikolski, et al.), hereby incorporated herein by reference in its entirety.

The accelerometer signal is used to determine a sensor-indicated rate (SIR) used to set a pacing escape interval for controlling the pacing rate to meet the metabolic demand of the patient. The atrial pacing escape interval or the ventricular pacing escape interval during single chamber pacing modes is initially set according to a programmed lower or base pacing rate to provide bradycardia pacing. The lower or base pacing rate may be automatically adjusted to provide rate responsive pacing based on a sensor signal indicative of the patient's metabolic demand, such as a signal from accelerometer **212**. The use of a patient activity signal for providing rate-responsive pacing is generally disclosed in U.S. Pat. No. 7,031,772 (Condie, et al.), incorporated herein by reference in its entirety.

The signal produced by accelerometer **212** may additionally or alternatively be used by control module **206** to detect motion of another heart chamber for monitoring purposes. For example, when pacemaker **100** is positioned in the RA as the RA pacemaker **12** in FIG. 1, a motion artifact on the accelerometer signal due to ventricular contraction at the onset of the ventricular systolic ejection phase, may be identified as a surrogate for sensing FF R-waves as evidence of ventricular depolarization. A time interval between an atrial event, paced or sensed, and the surrogate ventricular depolarization signal identified from the accelerometer signal may be measured as an AV conduction time and used for AV conduction time monitoring by the RA pacemaker **12**. As described below, AV conduction time monitoring by RA pacemaker **12** may be enabled during a solo operating mode to determine a need for RV pacemaker **14** based on increased AV conduction time.

Power source **214** provides power to each of the other modules and components of pacemaker **100** as required. Control module **206** may execute power control operations to control when various components or modules are powered to perform various pacemaker functions. Power source **214** may include one or more energy storage devices, such as one or more rechargeable or non-rechargeable batteries. The connections between power source **214** and other pacemaker modules and components are not shown in FIG. 3 for the sake of clarity.

Telemetry module **208** includes a transceiver and associated antenna for transferring and receiving data via a radio frequency (RF) communication link. RF communication with external device **20** (FIG. 1), may occur in the Medical Implant Communication Service (MICS) band, the Medical

Data Service (MEDS) band, or other frequency bands, including, but not limited to a 2.4 GHz industrial, scientific and medical (ISM) band for Bluetooth and IEEE 802.11 b/g/n standards. Telemetry module **208** may be capable of bi-directional communication with external device **20** over a wide range of distances, e.g., up to approximately 10 meters. In other examples, telemetry communication may require the use of a programming head placed in proximity of pacemaker **100** to facilitate data transfer.

FIG. 4 is a conceptual diagram **300** of the self-configuring operating modes of an intracardiac pacemaker **100** included in an IMD system, such as system **10** of FIG. 1. The IMD system **10** includes at least one intracardiac pacemaker **100** and may include two or more intracardiac pacemakers, e.g. RA pacemaker **12** and RV pacemaker **14** and an LV pacemaker. Each pacemaker may be implantable wholly within a heart chamber and therefore capable of delivering cardiac pacing in a single chamber using an electrode bipole, e.g., electrodes **162** and **164**. In some examples, the IMD system includes at least one intracardiac pacemaker and may include one or more other cardiac monitoring or therapy delivery devices such as an ICD or subcutaneous ECG monitor.

A first intracardiac pacemaker **100** is implanted and self-configures in a solo operating mode as indicated by state **302**. The first intracardiac pacemaker operating in a solo mode establishes whether a second intracardiac pacemaker is present. The presence of a second intracardiac pacemaker may be established based on a signal received from an external device **20** notifying the first pacemaker that the second pacemaker has been implanted. Alternatively, the presence of a second intracardiac pacemaker may be established based on sensing FF pacing pulse signals by the sensing module **204** of the first pacemaker **100**.

If a second pacemaker is detected as indicated by transition **304**, the first pacemaker reconfigures itself to a duo operating mode in state **306**. The second pacemaker likewise establishes the presence of the first pacemaker and self-configures in a duo operating mode in state **306**. The second pacemaker being implanted may receive a notification signal from the external device **20** indicating the presence of the first pacemaker. The second pacemaker automatically configures itself in the duo operating mode in state **306** in response to the command. Alternatively, the second pacemaker, upon being implanted, may sense FF pacing pulses being delivered by the first pacemaker from the EGM signal received by the second pacemaker and automatically configure itself in the duo operating mode **306**.

In one example, the first device implanted is the RA pacemaker **12** and the second device implanted is the RV pacemaker **14**. In another example, the first device is the RV pacemaker **14** and the second device is the RA pacemaker **12**. In yet another example the first device implanted is either a RA pacemaker or a LV pacemaker and the second device is the other of the RA pacemaker and the LV pacemaker.

The time between implanting the first pacemaker and the second pacemaker may vary between patients. In some cases both pacemakers may be implanted in the same procedure such that both devices self-configure in the duo operating mode immediately or soon after implantation. In other examples, implantation of the second pacemaker may occur days, weeks, months or even years after the first pacemaker.

In some examples a third intracardiac pacemaker may be detected by the first and second pacemakers, as indicated by transition **308**. The first and second pacemakers may automatically switch from a duo mode to a trio mode in state

310. Likewise, the third intracardiac pacemaker will self-configure in the trio mode 310 based on detection of the first and second pacemakers, automatically in response to FF sensed pacing pulses or in response to a notification received from an external device. In one example, a trio mode enables an intracardiac pacemaker 100 to sense FF events in one or two other heart chambers and use the FF events to monitor the patient's heart rhythm and/or trigger or inhibit pacing pulses delivered in the heart chamber that the pacemaker 100 is implanted in, based on the FF events.

In some cases, another device that is not an intracardiac pacemaker may already be present or implanted after an intracardiac pacemaker. If another IMD other than an intracardiac pacemaker 100 is present, the intracardiac pacemaker 100 may modify its self-configured solo, duo, or trio mode to operate in a manner that is desired when the other IMD is present. As such, the solo, duo and trio operating modes may refer to operating modes that enable one, two or three intracardiac pacemakers to operate appropriately alone or cooperatively with one or more other intracardiac pacemakers. Each of the solo, duo and trio operating modes may be modified based on the presence of another implantable device other than an intracardiac pacemaker. For example, a modified solo, duo or trio operating mode may disable an intracardiac pacemaker function to eliminate redundant functions that can be performed by another IMD and thereby conserve battery energy of the intracardiac pacemaker.

In other examples, a modified solo, duo or trio operating mode of intracardiac pacemaker 100 may enable a feature or function available in the pacemaker that is not used unless another IMD is present. To illustrate, an intracardiac pacemaker 100 operating in solo mode or operating in a duo mode when another intracardiac pacemaker is present may modify its solo or duo mode when an ICD is implanted include anti-tachycardia pacing (ATP) delivery. ATP delivery by an IMD system may be undesired unless defibrillation capabilities are available. When an ICD is added to the IMD system, any intracardiac pacemakers present may modify their current operating mode to include ATP.

Implantable devices may be added or removed from the IMD system present in a patient. As such, if three intracardiac pacemakers are present and operating in the trio mode 310, one pacemaker may be removed or disabled as indicated by transition 312. In some cases, an implanted pacemaker may not be physically removed from the patient but may reach battery end-of-life or be "turned off" such that it is no longer functional in the implanted IMD system or is no longer delivering pacing therapy. The remaining two devices will detect the removal of the second device from the system, either automatically based on sensed EGM signals or by receiving a notification from an external device. The remaining pacemakers will self-configure in the duo operating mode in state 306. If another pacemaker is removed from the system as indicated by transition 314, the remaining pacemaker detects the removal and reconfigures itself in the solo operating mode in state 302.

The solo mode in state 302, duo mode in state 306, trio mode in state 310 and so on for each intracardiac pacemaker present in an IMD system may be uniquely defined for the given pacemaker and for a given combination of pacemakers. For example, if the RA pacemaker 12 is present initially and operating in the solo mode in state 302, it may reconfigure to a duo operating mode including one set of features and control parameters in response to detecting the presence of a second pacemaker, such as RV pacemaker 14 but switch to a different duo mode of operation including a different set of features and control parameters in response to detecting

the presence of a different pacemaker such as a LA pacemaker. As such, for each intracardiac pacemaker that may be introduced to the overall IMD system a unique solo mode of operation may be defined in addition to one or more duo operating modes each defined according to the type and/or location of the second pacemaker that is implanted, one or more trio modes each defined according to the type and location of the third pacemaker that is implanted, and so on.

While the presence of up to three implantable pacemakers is depicted in FIG. 4, the methods disclosed herein may be extended to four intracardiac pacemakers operating in each of the four heart chambers, in which case a quad mode may be defined for each pacemaker. Each intracardiac pacemaker may further include self-configured, modified operating modes used when other types of IMDs are present, such as a modified solo operating mode with an ICD present, modified duo operating mode with an ICD present, etc.

FIG. 5 is a flow chart 400 of the operation of an intracardiac atrial pacemaker 12 and an intracardiac ventricular pacemaker 14 both enabled to automatically configure respective solo and duo operating modes according to the presence or absence of the other pacemaker. In one illustrative example, an intracardiac atrial pacemaker, such as RA pacemaker 12, is implanted first at block 402. Many patients may require bradycardia atrial pacing without requiring ventricular pacing due to normal atrioventricular conduction. The atrial pacemaker is initially configured in the solo mode as indicated at block 404.

The atrial pacemaker 12 may be provided by the manufacturer in the solo operating mode by default or may self-configure in the solo mode in response to a notification from a programmer (or other external device) indicating the atrial pacemaker is the sole pacemaker, i.e., no other intracardiac pacemakers are previously or simultaneously implanted. The solo operating mode may be defined by a combination of pacemaker features and control parameters that control both monitoring functions of the atrial pacemaker and therapy delivery functions of the atrial pacemaker.

For example, in a solo operating mode, the atrial pacemaker 12 may be configured to operate as single chamber atrial pacemaker delivering bradycardia pacing in an AAI or AAIR pacing mode. As used herein, the "operating mode" refers to the overall functions of the pacemaker which may include physiological signal monitoring, bradycardia pacing, one or more other types of cardiac stimulation therapy delivery such as ATP or cardiac resynchronization therapy (CRT), self-diagnostic testing and other device functions. As such, the bradycardia pacing mode designated by the three or four letter sequence indicating which chamber bradycardia pacing is delivered in and which chamber(s) cardiac events are sensed in for use in controlling the timing of the bradycardia pacing pulses is one aspect of the overall operating mode. One or more programmable pacing modes may be available within a given solo or duo operating mode.

In a solo operating mode configured at block 404, AV conduction block monitoring is turned on in one example. AV conduction block monitoring is turned on by enabling the atrial intracardiac pacemaker to sense FF R-waves for measuring time intervals between NF P-wave sensed event signals and FF R-wave sensed event signals received by the control module from the sensing module. An absence or latency of FF R-waves is an indication of the development of AV block and may indicate a need for an intracardiac ventricular pacemaker. AV block monitoring may therefore be enabled, i.e., turned "on", in the solo mode at block 404. Data relating to evidence of AV block based on FF R-wave

sensing may be stored by the atrial pacemaker and transmitted to the external device (a programmer, home monitor, or other external device **20** as shown in FIG. 1) to alert a clinician or other user to the possible need for ventricular pacing.

The solo operating mode configured at block **404** further includes an atrial (A) bradycardia pacing mode, e.g., AAI or AAIR mode. In some examples, no other therapies are enabled in the solo operating mode besides single chamber pacing. Even though the atrial pacemaker may be configured for sensing FF R-waves in the solo operating mode, the pacing mode is designated as the AAI(R) mode since only NF P-waves inhibit a scheduled atrial pacing pulse and only NF P-waves or atrial pacing pulses (but not FF R-waves) are used to start atrial pacing escape intervals. The atrial pacemaker is configured for dual chamber sensing in the solo operating mode since FF R-waves may be sensed by the pacemaker even though the atrial pacemaker does not receive EGM signals from electrodes positioned in the ventricle. This “pseudo” dual chamber sensing of both NF P-waves and FF R-waves may not be used in the timing and control of atrial pacing pulses, however, and the solo pacing mode is therefore referred to as AAI(R).

The solo operating mode of the atrial pacemaker may additionally include FF ventricular pacing pulse monitoring (FF V PACE MONITORING ON). A FF sensing channel of the RA pacemaker may be enabled to sense FF ventricular pacing pulses to detect the presence of an intracardiac ventricular pacemaker.

At block **408**, a ventricular pacemaker, such as RV pacemaker **14**, may be detected. Detection of a ventricular pacemaker by the atrial pacemaker may be based on a received telemetry signal from an external device. Alternatively or additionally, the solo operating mode of the atrial pacemaker may include automatic detection of ventricular pacemaker based on FF ventricular pacing pulse monitoring enabled during the solo operating mode (block **404**). If FF ventricular pacing pulses are sensed, detection of a ventricular pacemaker may be confirmed at block **408** based upon ventricular pacemaker detection criteria, e.g., a minimum required number of FF ventricular pacing pulse sensed events within a predetermined interval of time or predetermined number of atrial cardiac cycles (PP intervals). If no ventricular pacing pulses are sensed or the ventricular pacemaker detection criteria are not satisfied, and/or no notification signal is received from an external device, the atrial pacemaker remains in the solo mode (block **404**).

A ventricular pacemaker, such as RV pacemaker **14** may be implanted, as indicated at block **420**, at any time prior to, concomitantly with, or subsequently to the atrial pacemaker implantation. If RV pacemaker **14** is detected by RA pacemaker **12** at block **408**, RA pacemaker **12** automatically configures itself in a duo operating mode at block **410**. The atrial pacemaker duo operating mode may include adjustments to monitoring functions and/or therapy delivery functions.

For example, since a ventricular pacemaker is now present, AV block monitoring that was enabled during the solo operating mode for the purposes of determining a need for a ventricular pacemaker may be disabled or turned “off” at block **410**. Since a ventricular pacemaker is available to provide back-up ventricular pacing, the atrial pacemaker may monitor for atrial tachycardia (AT) or atrial fibrillation (AF) according to an implemented tachyarrhythmia detection algorithm (AT/AF DETECTION ON). The atrial duo operating mode may enable atrial ATP therapy (ATRIAL ATP ON) in addition to providing bradycardia pacing.

Without the ventricular pacemaker present, it may be undesirable to deliver atrial ATP since it could lead to an irregular ventricular rhythm. In response to detecting RV pacemaker **14**, RA pacemaker **12** may automatically enable AT/AF detection and atrial ATP therapy capabilities.

During the duo operating mode, atrial bradycardia pacing may be configured to use a higher pacing pulse amplitude and/or pulse width than used during the solo mode for bradycardia pacing. For example, the atrial pacing pulse amplitude may be increased by increasing a pacing safety margin that is added to an atrial pacing capture threshold. A higher pacing safety margin may be used during the duo operating mode compared to the pacing safety margin used during the solo operating mode. The higher atrial pacing pulse amplitude resulting from adding a higher safety pacing margin promotes reliable sensing of the FF atrial pacing pulse by the ventricular pacemaker. Alternatively, a fixed high atrial pacing pulse amplitude or pulse width may be used during the duo operating mode that is expected to be above the atrial pacing capture threshold and easily sensed by the ventricular pacemaker as a FF pacing pulse with a high degree of confidence. As such, the self-configured duo operating mode may include increasing the pacing safety margin as indicated at block **410** or otherwise setting a high atrial pacing pulse amplitude or pulse width.

Upon configuring the duo operating mode at block **410**, the atrial pacemaker provides a signal to the programmer or other external device, e.g., upon the next interrogation command from the external device, indicating the duo operating mode has been configured and enabling the external device to display relevant programmable control parameters. For example, even if AT/AF detection and atrial ATP are enabled, a user may still be able to turn these features on or off using the external programmer. When turned on, relevant programmable control parameters such as AT/AF detection criteria and ATP control parameters may be displayed.

Some parameters or features included in the duo operating mode may be non-programmable parameters. For example, the increased atrial pacing pulse amplitude may be a fixed parameter so that a user may not inadvertently set the amplitude too low to be reliably sensed by the ventricular pacemaker.

After switching to the duo operating mode, the atrial pacemaker may continue to monitor for the presence of the ventricular pacemaker. If the ventricular pacemaker is no longer present (or functioning), the atrial pacemaker may return to the solo mode by returning to block **404**. Detecting that the ventricular pacemaker is no longer present may be based on receiving a notification from an external device or detecting a disappearance of FF ventricular pacing pulse sensed event signals from a FF sensing channel **224**. An extended period time of no FF ventricular pacing pulse sensed event signals may be required to determine that the RV pacemaker **14** is no longer present compared to the time required to detect that RV pacemaker **14** is present based on sensing FF ventricular pacing pulses. For example, at least one day of no FF ventricular pacing pulse sensed events may be required before the RA pacemaker control module **206** determines that the RV pacemaker **14** is no longer present. The RV pacemaker **14** may be configured to deliver a predetermined number of pacing pulses, e.g., 8 pacing pulses, at an overdrive pacing rate greater than an intrinsic heart rate and/or at a high pulse output at least once per day to reduce the likelihood of RA pacemaker control module **206** determining that RV pacemaker **14** is no longer present. Similarly, RA pacemaker **12** may be configured to deliver a

predetermined number of pacing pulses at an overdrive rate and/or increased pulse output to reduce the likelihood that RV pacemaker **14** does not falsely determine that RA pacemaker **12** is no longer present.

When a ventricular pacemaker, e.g., RV pacemaker **14** or an LV pacemaker, is implanted as indicated at block **420**, it may initially determine if an atrial pacemaker is detected at block **422**. Detection of an atrial pacemaker may be based on receipt of a telemetry notification signal from a programmer or other external device **20** or based on monitoring a ventricular EGM signal for the occurrence of FF atrial pacing pulses. The ventricular pacemaker may be provided in a solo mode as a default mode or a duo mode as a default mode. If the atrial pacemaker is detected at block **422**, the ventricular pacemaker configures itself in the duo operating mode (which may be a matter of maintaining a default mode) at block **430**. The duo operating mode of the ventricular pacemaker may alter both monitoring and therapy delivery functions of the ventricular pacemaker compared to the ventricular pacemaker solo operating mode.

For example, during the duo mode, the ventricular pacemaker may be configured to sense FF P-waves, which may include intrinsic or evoked P-waves, and FF atrial pacing pulses. The ventricular pacemaker may use the sensed atrial events, including both FF sensed atrial pacing pulses and FF sensed P-waves, for controlling the timing of the ventricular pacing pulses. As such, the ventricular duo operating mode configured at block **430** includes enabling FF atrial pacing pulse sensing.

The duo operating mode may include the options of VVI(R) and VDD(R) pacing modes. Alternatively, the duo operating mode may include only the VDD(R) pacing mode. During VVI(R) pacing, a NF R-wave sensed during an escape interval inhibits a scheduled ventricular pacing pulse and restarts the escape interval. FF atrial sensed events are not used to inhibit or trigger a ventricular pacing pulse. In the VDD(R) pacing mode, FF atrial sensed events, including FF atrial pacing pulse sensed events and FF P-wave sensed events, are used to trigger a ventricular pacing pulse at an AV interval to provide atrial-synchronized ventricular pacing. The synchronized single-chamber VDD(R) pacing mode of ventricular pacemaker in combination with the AAI(R) pacing mode of the atrial pacemaker provide DDD(R) pacing. By sensing FF atrial events by sensing module **204** in the ventricular pacemaker, the two separate atrial and ventricular intracardiac pacemakers, e.g. pacemakers **12** and **14**, are enabled to provide DDD(R) pacing, which is described in greater detail below.

During the duo operating mode, the ventricular pacemaker pacing mode may be programmable as a VVI(R) mode or a VDD(R) mode. When programmed in a VVI(R) mode (instead of VDD(R) mode), with an atrial pacemaker present and operating in an AAI(R) mode, a DDI(R) mode is achieved (instead of a VDD(R) mode). The atrial pacemaker provides pacing and sensing in the atrial chamber and inhibits atrial pacing pulses in response to NF atrial sensed events. The ventricular pacemaker provides pacing and sensing in the ventricular chamber and inhibits ventricular pacing pulses in response to NF ventricular sensed events. The ventricular pacemaker is also enabled to sense FF atrial events but does not trigger a ventricular pacing pulse at an AV delay in response to a FF atrial sensed event as it does during a VDD(R) mode. A DDI(R) pacing mode is useful for patients with paroxysmal AF. An AV interval may be started in response to a FF atrial pacing pulse sensed event, but a FF non-paced sensed event, i.e., an intrinsic FF P-wave sensed event, does not start an AV interval. The ventricular pace-

maker paces the ventricle at the programmed lower rate or the sensor indicated rate interval when FF P-wave sense events signals are produced (corresponding to intrinsic P-waves) in the absence of FF atrial pacing pulse sensed events.

Self-configuration of the duo operating mode by the ventricular pacemaker may further include enabling atrial tachycardia/atrial fibrillation (AT/AF) detection by the ventricular pacemaker and automatic pacing mode switching based on AT/AF detection, as indicated in block **430**. The ventricular pacemaker may automatically switch between VDD(R) and VVI(R) pacing modes based on AT/AF detection by the ventricular pacemaker.

The atrial pacemaker may be enabled to detect the presence of AT/AF using NF P-wave sensing (as indicated at block **410**) but may not be configured to send a communication signal to the ventricular pacemaker to indicate that an AT/AF detection has been made. The ventricular device may be configured during the duo mode to detect AT/AF based on a disappearance of both FF atrial pacing pulse sensed events and FF P-wave sensed events. P-waves during AF will be relatively low amplitude compared to P-waves during sinus rhythm resulting in a loss of P-wave sensing or intermittent P-wave sensing. In some cases, FF P-wave sensed event signals could be produced at a high rate by the ventricular pacemaker sensing module during AF if the P-wave amplitude is high enough during AF. Accordingly, the ventricular pacemaker may be enabled to detect AF during a duo operating mode based on AF detection criteria which may include FF sensed event signals occurring below a minimum rate, no FF sensed event signals for a predetermined interval of time, and/or a FF P-wave sensed event signal rate that is greater than a predetermined pacing mode switch threshold rate.

Alternatively, the atrial pacemaker may be configured to detect AF and deliver atrial pacing pulses at a particular rate or sequence to signal the ventricular pacemaker that AF has been detected. The ventricular pacemaker detects AF in response to sensing the FF atrial pacing pulse events at the particular rate or sequence.

When AF is detected by the ventricular pacemaker, the control module **206** automatically switches the VDD(R) pacing mode to the VVI(R) pacing mode. A return of FF sensed event signals produced by the FF sensing channel **224** at a rate greater than a minimum rate and below a mode switch threshold rate causes the ventricular pacemaker control module **206** to return the pacing mode to VDD(R). In this way, the separate atrial pacemaker and ventricular pacemaker can operate cooperatively to provide dual chamber pacing in patients having AF by providing atrial-synchronized ventricular pacing, i.e., DDD(R) pacing, when AF is not detected by the ventricular pacemaker and DDI(R) pacing when AF is detected.

The ventricular duo operating mode may include other monitoring functions. For example, an AV conduction time (AVCT) test may be enabled at block **430**. An AVCT test may be performed periodically to determine if AV conduction is intact in a patient that may have varying degrees of or intermittent AV block. The ventricular pacemaker control module **206** may periodically extend an AV interval being used to control the timing of ventricular pacing pulses following sensed FF atrial events to allow time for an intrinsic R-wave to be sensed. The time interval between a sensed FF atrial event, which may be a FF atrial pacing pulse sensed event or a FF P-wave sensed event, and a subsequently sensed NF R-wave is determined as the AV conduction time.

The duo operating mode configured at block 430 may further include enabling minimum ventricular pacing (MVP). The AVCT test enabled at block 430 may be used by the ventricular pacemaker control module 206 to control MVP according to when AVCT is within an acceptable range. If AVCT is within an acceptable normal range, the ventricular pacemaker switches to atrial-based pacing in which ventricular pacing is withheld and only back-up ventricular pacing pulses are delivered at a relatively long AV interval, which may be a long paced AV (P-AV) interval following an atrial pacing pulse sensed as a far field pacing pulse event or a long sensed AV (S-AV) interval following a far field P-wave sensed event. For example, the ventricular pacing mode may be a VDD(R) mode with a longer AV interval than when AVCT is not within a predetermined acceptable range. The atrial-based pacing minimizes the number of ventricular pacing pulses being delivered and promotes ventricular depolarization by the natural conduction system of the heart via the AV node. If one or more back-up ventricular pacing pulses are delivered, or if the AVCT is determined to be longer than an acceptable normal range during atrial-based pacing, the ventricular pacemaker control module switches to atrial-synchronized ventricular pacing at a desired AV interval following sensed FF atrial events (FF atrial pacing pulse sensed events or FF P-wave sensed events). Sensing of FF atrial events by the ventricular pacemaker in the duo operating mode is described in greater detail below.

Periodically, the ventricular pacemaker may extend the AV interval during atrial-synchronized ventricular pacing according to the AVCT test protocol to detect a return of AV conduction within a normal range. The ventricular pacemaker may switch back to atrial-based pacing in response to the return of AVCT to a normal range. While the AVCT test and MVP features may be enabled during the duo operating mode of the ventricular pacemaker, each feature may be programmably turned on or off by a user according to individual patient need. Other relevant operating parameters may be made accessible to a user on the programmer or other external device, for example for programming a desired AV interval during atrial-triggered ventricular pacing for optimized atrioventricular synchrony and a relatively longer AV interval for delivering back-up ventricular pacing pulses during atrial-based MVP.

In the duo operating mode, the combination of the atrial pacemaker and the ventricular pacemaker operate together in a DDD(R) or DDI(R) mode even though neither device is delivering pacing pulses to both the atrial and ventricular chambers and neither device is sensing NF signals in both the atrial and ventricular chambers. The atrial pacemaker is operating in an AAI(R) pacing mode and the ventricular pacemaker is operating in a VDD(R) pacing mode or a VVI(R) pacing mode with the added functionality of sensing FF atrial events to provide the pseudo dual chamber sensing and desired response to FF sensed events (atrial paced sensed events or P-wave sensed events). Together the two devices operate in a DDD(R) or DDI(R) pacing mode and thus provide a wholly intracardiac DDD(R) or DDI(R) pacing system.

If the atrial pacemaker is not detected by the ventricular pacemaker at block 422, upon initial implant or at any later time during the duo operating mode, the ventricular pacemaker self-configures in a solo operating mode at block 424. For example, if the ventricular pacemaker no longer detects FF atrial pacing pulses for a predetermined interval of time or receives a wireless telemetry notification signal from an external device indicating the atrial pacemaker is not present

(at block 422), the ventricular pacemaker self-configures the solo operating mode at block 424.

In the solo mode configured at block 424, the sensing module 204 of the ventricular pacemaker may be enabled to sense ventricular R-waves only with VVI(R) being the only pacing mode available. Alternatively, the sensing module may be enabled to sense ventricular R-waves and FF P-waves with both VVI(R) and VDD(R) pacing modes available.

In the solo operating mode, therefore, both atrial-asynchronous ventricular pacing and atrial-synchronous ventricular pacing using FF P-wave sensing may be available. As indicated above, single chamber ventricular pacing with pseudo dual chamber sensing based on FF P-wave sensing is referred to herein as VDD(R) since pacing pulses are delivered in the ventricle, near-field R-waves and far-field P-waves are sensed in the ventricular and atrial chambers, respectively, using a single bipole of the single chamber device, and a dual response to sensed events is provided. The ventricular pacing pulse is inhibited in response to a NF R-wave sensed event signal during an AV interval, and a ventricular pacing pulse is triggered in response to a FF P-wave sensed event signal. In the solo operating mode, therefore, two different pacing modes may be selectable using external device 20. For example, a clinician or other user may be able to program the RV pacemaker 14 in FIG. 1 to a VVI(R) mode or VDD(R). Both options may be made available with corresponding programmable therapy control parameter settings, such as a lower rate for controlling ventricular pacing rate during the VVI(R) pacing mode and the AV interval for controlling the atrial-synchronized pacing pulses during VDD(R) pacing mode.

If the atrial pacemaker is detected during the solo mode at block 422, the ventricular pacemaker switches to the duo mode at block 430. The ventricular pacemaker may detect the presence of the atrial pacemaker in response to a wireless telemetry signal from an external device 20. Alternatively, the ventricular pacemaker solo operating mode may include monitoring FF atrial events periodically or continuously to detect FF atrial pacing pulses and thereby detect the presence of the atrial pacemaker.

An intracardiac pacemaker, atrial or ventricular, operating in a solo or duo mode may be configured to periodically deliver pacing pulses at an increased pacing pulse output, e.g., increased pulse amplitude and/or rate, to facilitate automatic detection of the pacemaker by another intracardiac pacemaker. For example, the atrial pacemaker self-configured in a solo operating mode at block 404 may periodically increase the atrial pacing pulse amplitude and/or periodically overdrive pace the atria if no atrial pacing pulses have been delivered for a predetermined interval of time. If no FF atrial pacing pulses are sensed by the ventricular pacemaker for an extended period of time due to sustained atrial sensing inhibiting the atrial pacing pulses, the ventricular pacemaker may incorrectly detect the removal or absence of the atrial pacemaker. Similarly, if no FF ventricular pacing pulses are sensed by the atrial pacemaker for an extended period of time due to ventricular sensed events inhibiting ventricular pacing pulses, the atrial pacemaker may incorrectly detect the removal or absence of the ventricular pacemaker.

As such, each pacemaker may be configured to periodically deliver pacing pulses at a rate that is greater than the intrinsic events, by shortening an appropriate pacing timing interval based on an atrial lower rate or SIR, ventricular lower rate or SIR, or AV interval. Periodic pacing at an interval shorter than intrinsic cardiac event intervals pro-

notes FF sensing of pacing pulses by another pacemaker and thereby maintains detection of the presence of one pacemaker by the other pacemaker. In other examples, pacing pulses may be delivered in a particular sequence by varying the pacing intervals in a particular way so that the FF pacing pulse sensed event signals produced by FF sensing channel 224 can be easily identified by the control module 206 as evidence of the presence of the other pacemaker.

In various embodiments, the pacing pulses sensed as FF pacing pulse events by the first pacemaker are therapeutic pacing pulses delivered in another heart chamber by another intracardiac pacemaker. The therapeutic pacing pulses are sensed by the first pacemaker as FF pacing pulse events for detecting the presence of the other pacemaker as opposed to non-therapeutic communication signals transmitted by the other pacemaker to the first pacemaker.

FIG. 6 is a functional block diagram 450 of sensing and pacing control modules included in intracardiac pacemaker 100 according to one example. In this illustrative embodiment, the functionality represented by diagram 450 is described with reference to a ventricular intracardiac pacemaker such as RV pacemaker 14 configured to sense FF atrial pacing pulses, FF atrial P-waves associated with intrinsic or evoked depolarizations of the atria, and NF R-waves. It is recognized that the functionality can be adapted to be included in an atrial intracardiac pacemaker for sensing FF ventricular pace signals, FF R-waves and NF P-waves.

A single bipolar pair of electrodes 162 and 164 is used for sensing the FF and NF events and for delivering ventricular pacing pulses in this example. As described above in conjunction with FIGS. 2B and 2C, the inter-electrode spacing may be increased by an extender to improve sensing of FF signals. The EGM signal developed across electrodes 162 and 164 is received by a wide-band analog filter, pre-amplifier and digital converter (DC) circuit 452. The digital output of circuit 452 is provided to three sensing channels 454, 456 and 458.

Each of the sensing channels 454, 456 and 458 may include different digital filters and cardiac event detectors to enhance sensing different events by each channel based on amplitude threshold crossings. For example, FF P-wave sensing channel 456 may be provided with a different bandpass filter and sensing threshold than R-wave sensing channel 458 to promote reliable sensing of FF P-waves and NF R-waves by the respective sensing channels 456 and 458. In other examples, FF-P-wave sensing channel 456 and/or NF sensing channel 458 may be configured to sense FF P-waves and NF R-waves using other criteria than a sensing threshold crossing, such as waveform morphology criteria. Upon a P-wave sensing threshold crossing (or other sensing threshold criteria being met), FF P-wave sensing channel 456 produces an atrial sense (AS) signal (also referred to herein as a FF P-wave sensed event signal) that is passed to the pace timing and control 460.

The R-wave sensing channel 458 produces a ventricular sense (VS) signal (also referred to herein as a NF R-wave sensed event signal) that is passed to pace timing and control 460 in response to the EGM signal received from circuit 452 crossing an R-wave sensing threshold. If the current pacing mode is VVI(R), the VS signal will inhibit a ventricular pacing pulse and restart a pacing escape interval. Pace timing and control 460 will start a lower rate or SIR pacing escape interval in response to the VS signal and produce a VP signal if the escape interval expires before another VS signal is received. The VP signal is passed to the pulse

generator 202 (not shown in FIG. 6) to cause delivery of a ventricular pacing pulse. If the current pacing mode is VDD(R), the VS signal will inhibit a ventricular pacing pulse and restart a lower rate or SIR pacing escape interval. If no AS signal is received from FF P-wave sensing channel 456 before expiration of the lower rate or SIR pacing escape interval, a ventricular pacing pulse is delivered. If an AS signal is received from FF P-wave sensing channel 456, pace timing and control 460 starts an AS-V interval to trigger ventricular pacing pulse delivery upon expiration of the AS-V interval. If a VS signal is received from R-wave sensing channel 458 during the AS-V interval, the pace timing and control inhibits the scheduled ventricular pacing pulse and restarts the lower rate or SIR escape interval.

The FF Apace sensing channel 454 is configured to produce a FFAP sense signal (also referred to herein as a FF atrial pacing pulse sensed event signal) in response to sensing a FF atrial pacing pulse. The FF Apace sensing channel 454 may include a narrow bandpass filter for passing a frequency characteristic of the atrial pacing pulse artifact. FF Apace sensing channel 454 may be configured to sense the atrial pacing pulse based on frequency content, slew rate, amplitude, pacing pulse artifact morphology, an over-range signal from the pre-amplifier in circuit 452, saturation of the digital converter in circuit 452, or any combination thereof. FF Apace sensing channel 454 may correspond to apparatus and methods for sensing a pacing pulse delivered in another heart chamber as generally disclosed in provisionally-filed U.S. Pat. Application No. 61/984,249, hereby incorporated herein by reference in its entirety.

As further described below in conjunction with FIGS. 7 and 8, the pace timing and control 460 included in the pacemaker control module 206 is configured to select between a sensed AV interval (SA-V interval) and a paced AV interval (PA-V interval) for providing atrial synchronized ventricular pacing in a VDD(R) pacing mode. The SA-V interval is started in response to receiving an AS signal from FF P-wave sensing channel 456. The PA-V interval is started in response to receiving a FFAP signal from FF Apace sensing channel 454.

When the ventricular pacemaker is operating in a VVI(R) pacing mode, the FF Apace sensing channel 454 and the FF P-wave sensing channel 456 may be disabled or any FFAP and AS signals may be ignored by pace timing and control 460. If the ventricular pacemaker is configured in the solo operating mode with a VDD(R) pacing mode selected, the FF P-wave sensing channel 456 may be enabled to provide atrial-synchronized ventricular pacing. The FF Apace sensing channel 454 may be disabled or ignored by pace timing and control 460 since no atrial pacemaker is present to produce atrial pacing pulses during the solo operating mode of the ventricular pacemaker. The FF Apace sensing channel 454 may be enabled, periodically or continuously during the solo operating mode, however, to provide FFAP signals to the control module 206 of the ventricular pacemaker for the purpose of monitoring for the presence of an atrial intracardiac pacemaker.

When the ventricular pacemaker is configured in the duo operating mode with VDD(R) pacing, both the FF Apace sensing channel 454 and the FF P-wave sensing channel 456 are enabled and FFAP signals and AS signals received by pace timing and control 460 are used for setting respective PA-V intervals and SA-V intervals. When the pace timing and control 460 receives a FFAP signal, a subsequent AS signal during the PA-V interval is ignored. The AS signal may be produced in response to sensing an evoked P-wave

following the FFAP signal. A P-wave sensing blanking window may be applied to FF P-wave sensing channel 456 in some examples for preventing an evoked P-wave from causing an AV interval to be restarted (i.e., an SA-V interval to be started during a PA-V interval) before delivering a pacing pulse at the PA-V interval.

Depending on the orientation of the atrial pacemaker and the ventricular pacemaker relative to one another, the atrial pacing pulse may not always be sensed by the ventricular pacemaker. For example, it is expected that when a RA pacemaker is substantially orthogonal to the RV pacemaker, sensing of the FF atrial pacing pulses is minimized. The relative orientation of the RA and RV pacemakers may be unknown and may change over time, e.g., due to respiration, posture or other motion. As such, the RV pacemaker may sense the FF atrial pacing pulse at times and at other times may sense the FF evoked P-wave. When the FF atrial pacing pulse is not sensed, the evoked P-wave sensed by the FF P-wave sensing channel 456 will cause an SA-V interval to be started by pace timing and control 460. Since the evoked response P-wave occurs upon atrial depolarization, the SA-V interval provides the proper timing of the ventricular pacing pulse for desired AV synchrony whether the AS signal is produced in response to sensing an intrinsic or an evoked FF P-wave.

When the atrial pacing pulse is sensed earlier than the evoked depolarization of the atrium, however, using the SA-V interval would cause the ventricular pacing pulse to be delivered earlier than the desired AV interval. Early contraction of the ventricle may truncate ventricular filling. As such, the PA-V interval, set longer than the SA-V interval, is selected in response to the FFAP signal. Otherwise the SA-V interval is selected in response to either an intrinsic or evoked FF P-wave, which may not be distinguished from each other by FF P-wave sensing channel 456.

In another example, the FFAP signal from FF Apace sensing channel 454 may cause pace timing and control 460 to set a short blanking interval then sense the evoked P-wave by FF P-wave sensing channel and start the SA-V interval in response to the AS signal. The FFAP signal is not used to start an AV interval but is used to prevent the pace artifact from being detected as an evoked FF P-wave and to indicate when to start looking for the evoked FF P-wave signal.

FIG. 7 is a timing diagram 470 depicting the operation of RA pacemaker 12 and RV pacemaker 14 when configured in duo operating modes. The RA pacemaker 12 delivers an atrial pacing (AP) pulse 472, starts a lower rate (or SIR) escape interval 475, and delivers a next AP pulse 476 upon expiration of the escape interval 475. An atrial evoked response (ER) 474 caused by pacing pulse 472 may be ignored by the RA pacemaker by applying a blanking or refractory period 473 following AP 472 so that the escape interval 475 is not restarted in response to ER 474.

The RV pacemaker 14 senses the FF atrial pacing pulse and produces a FF atrial pacing pulse sensed event signal (FFAP) 480 that starts a PA-V interval 490. If an AS signal 482 is produced in response to sensing the ER 474 by the FF P-wave sensing channel (456 in FIG. 6), it does not cause an AS-V interval to be started during the PA-V interval 490. In some examples, a P-wave refractory period 484 may be applied following the FFAP signal 480 to ignore AS events that are likely to be evoked P-waves following the FFAP 480. If a NF R-wave is not sensed by the RV pacemaker during the PA-V interval 490, a ventricular pacing pulse (VP) 492 is delivered at the expiration of PA-V interval 490.

At expiration of the atrial escape interval 475, an AP 476 is delivered followed by an ER 478. In this case, the AP 476

is not sensed by the ventricular pacemaker, however the FF evoked P-wave corresponding to ER 478 is sensed as an AS event 486 by the FF P-wave sensing channel 456. An SA-V interval 494, that is shorter than PA-V interval 490, is started by the pace timing and control module (460 in FIG. 6) in response to the AS 486. Ventricular pacing pulse VP 496 is delivered upon expiration of the SA-V interval 494.

An intrinsic P-wave 479 occurs during the next atrial escape interval 475'. The P-wave 479 is sensed as a FF AS event 488 by the RV pacemaker 14. The RV pacemaker 14 starts the SA-V interval 494' and delivers a subsequent VP 498 at the same AV interval after intrinsic P-wave 479 as after the ER 478. By proper selection of a PA-V or SA-V interval by pace timing and control 460, each of VP 492, VP 496, and VP 498 are delivered at the same effective AV interval following atrial depolarization whether the depolarization is an evoked response 474 or 478 or an intrinsic P-wave 479 and regardless whether the atrial pacing pulse 472, 476 is sensed or not. The P-AV and the S-AV intervals may each take into account any delay in sensing the FF atrial events by the RV pacemaker 14.

FIG. 8 is a flow chart 500 of a method for controlling ventricular pacing by an intracardiac ventricular pacemaker, such as RV pacemaker 14 shown in FIG. 1. At block 501, the RV pacemaker 14 self-configures in either a solo or duo operating mode. Control module 206 self-configures the solo mode when no other implanted intracardiac pacemaker is present. The RV pacemaker 14 configures itself in a duo mode when an atrial intracardiac pacemaker, such as RA pacemaker 12, is present.

If the ventricular pacemaker operating mode is a solo mode ("yes" branch of block 501), the control module 206 may enable either a VVI(R) pacing (atrial asynchronous) or VDD(R) pacing (atrial synchronous) mode. A user may selectively program the pacing mode desired to be in effect during the solo operating mode. At block 502, the control module 206 determines if the currently programmed pacing mode is VVI(R) or VDD(R).

If the programmed pacing mode is VVI(R), the control module 206 starts a lower rate (or SIR) pacing escape interval to control a lower ventricular pacing rate at block 503. The escape interval is started in response to a delivered ventricular pacing pulse or in response to sensing a NF R-wave by the sensing module 204. If an R-wave is sensed at block 504 prior to the escape interval expiring, the escape interval is restarted at block 503. If an R-wave is not sensed prior to the escape interval expiring, a ventricular pacing pulse is delivered at block 505 at the expiration of the escape interval. The escape interval set at block 503 may be adjusted according to a sensor-indicated pacing rate to meet the metabolic needs of the patient, based for example on a patient activity signal received from an accelerometer.

The ventricular intracardiac pacemaker may remain in this VVI(R) pacing mode as long as the solo operating mode remains (as determined at block 501) and the programmed pacing mode remains VVI(R) (as determined at block 502).

The ventricular pacemaker may be programmed to operate in a VDD(R) pacing mode during the solo operating mode. The VDD(R) pacing mode includes delivering pacing pulses in the ventricle, pseudo dual chamber sensing by sensing both NF ventricular events and FF atrial events, and providing a dual pacing response to sensed events wherein pacing pulses are triggered by a FF atrial event and inhibited by sensing a NF ventricular event. The ventricular rate may be controlled in a rate-responsive manner based on a patient activity signal.

If the programmed pacing mode is VDD(R) during the solo operating mode (affirmative result at decision block **502**), atrial-synchronized ventricular pacing is delivered. A patient may have normal sinus node function with AV conduction block requiring ventricular pacing. These patients may benefit from atrial-synchronized ventricular pacing requiring only an intracardiac ventricular pacemaker. When a FF P-wave is sensed at block **506**, the control module **206** starts an AV interval at block **507**.

If a NF R-wave is sensed at block **508**, the ventricular pacing pulse scheduled to occur upon the expiration of the AV interval is inhibited at block **511** by starting a VV pacing escape interval set according to the lower rate (LR) or SIR. The control module **206** waits for the next FF P-wave sensed event at block **506**. If no FF P-wave is sensed at block **506** before expiration of the VV pacing escape interval, a ventricular pacing pulse is delivered by pulse generator **202** at block **510**.

If the AV interval started at block **507** in response to a sensed FF P-wave expires without sensing a NF R-wave at block **508**, a ventricular pacing pulse (VP) is delivered at block **509** at the expiration of the AV interval. After delivering the VP, the control module **206** starts a VV pacing escape interval and waits for the next FF P-wave sensed event at block **506**. All FF P-wave events sensed at block **506** are intrinsic P-waves since an atrial pacemaker is not present in this case. The VDDR pacing mode may be achieved by the intracardiac pacemaker positioned wholly in the ventricle and using a single bipolar pair of electrodes for delivering the ventricular pacing pulses, sensing the NF R-waves and the FF P-waves.

If the RV pacemaker **14** is operating in a duo operating mode (negative result at block **501**), the RV pacemaker **14** monitors the EGM signal received by the sensing module **204** for a FF atrial pacing pulse event at block **512**. For the sake of the flow chart **500**, it is assumed that during the duo operating mode, the RV pacemaker **14** is programmed to deliver VDD(R) pacing, by default or by user selection. It is recognized, however, that depending on patient need, a VVI(R) pacing mode may still be available and programmed by a user during the duo operating mode, in which case the flow of blocks **503** through **505** would be followed.

In the duo operating mode with VDD(R) pacing mode programmed, if a FF atrial pacing pulse event is sensed at block **512**, a PA-V interval is started at block **513**. During the duo operating mode, the RV pacemaker control module **206** selects between an SA-V interval and an PA-V interval based on whether the FF sensing channel **224** has produced a FF atrial pacing pulse sensed event signal, as determined at block **512**, or a FF P-wave sensed event signal as determined at block **520**. The PA-V interval is started at block **513** in response to an affirmative result at decision block **512**, and the SA-V interval is started at block **522** in response to an affirmative result at decision block **520**. The PA-V interval is typically longer than the SA-V interval since there will be a short delay between delivery of the atrial pacing pulse and the evoked response of the atrium, though there may be cases that the PA-V is shorter than the SA-V depending on the relative conduction times of the atrial evoked response and the intrinsic atrial depolarization to the ventricle. If a NF R-wave is sensed during the PA-V interval at block **514**, the ventricular pacing pulse is inhibited at block **518**. The control module **206** restarts a LR or SIR escape interval at block **530** and waits for the next FF atrial sensed event at blocks **512** and **520**, a FF atrial pacing pulse sensed event or a FF P-wave sensed event, whichever comes first. If the PA-V interval expires without sensing a

NF R-wave at block **514**, a ventricular pacing pulse is delivered at block **516** upon expiration of the PA-V interval.

If the next atrial sensed event is a FF P-wave, as determined at decision block **520**, the control module **206** starts an SA-V interval at block **522**. If a NF R-wave is not sensed prior to expiration of the SA-V interval (block **524**), a ventricular pacing pulse is delivered by pulse generator **202** at block **526** upon expiration of the SA-V interval. If a NF R-wave is sensed during the SA-V interval (block **524**), the ventricular pacing pulse is inhibited at block **528**. The control module restarts a LR or SIR escape interval at block **532** and waits for the next sensed atrial event at block **512** or block **520**. In this way, the RV pacemaker **14** selects from a PA-V interval or an SA-V interval based on whether the FF sensed atrial event is a FF sensed atrial pacing pulse (block **512**) or a FF sensed P-wave (block **520**). The resulting ventricular pacing pulses are delivered at a desired AV interval following the atrial depolarization, whether it is an evoked response or an intrinsic depolarization.

If neither a FF atrial pacing pulse nor a FF P-wave is sensed at blocks **512** or **520** during a LR or SIR escape interval started at blocks **530** or **532**, the ventricular pacemaker delivers the ventricular pacing pulse upon expiration of the escape interval at block **534**. A new escape interval is started at block **530** in response to the ventricular pacing pulse, and the control module **206** waits for the next FF sensed event at blocks **512** and **520**.

During the atrial-synchronized ventricular pacing delivered by RV pacemaker **14** in the duo operating mode, the RA pacemaker **12** may be operating as an AAI pacemaker for pacing in the RA, sensing RA EGM signals, and inhibiting a RA pacing pulse in response to sensing a P-wave prior to the expiration of an atrial pacing escape interval. The RA pacemaker **12** operating as an AAI(R) pacemaker and the RV pacemaker operating as a VDD(R) pacemaker achieves DDD(R) pacing therapy delivered to the patient. The VDD(R) pacing is responsive to dual chamber sensing even though no sensing electrodes positioned in the atria are coupled directly to the RV pacemaker. Dual chamber sensing is achieved by sensing FF atrial events from the ventricular EGM signal. The FF atrial events may include atrial pacing pulses delivered by the RA pacemaker and FF P-waves, intrinsic or evoked. Thus a dual response of atrial-triggered ventricular pacing with ventricular pacing pulses inhibited by NF R-waves is achieved. A synchronized single chamber pacing mode is therefore available in both solo and duo operating modes where the single chamber pacing, in this case ventricular pacing, is synchronized to FF sensed events, in this case FF atrial events for achieving atrial-synchronized ventricular pacing.

FIG. 9 is a conceptual diagram of another example of an IMD system **10'** including multiple, self-configuring intracardiac pacemakers and other implantable, extracardiac devices. IMD system **10'** is shown to include RA pacemaker **12** and RV pacemaker **14** as previously shown in FIG. 1. Other IMDs that may be implanted in a patient include an LV intracardiac pacemaker **16** and extracardiac IMDs, such as ECG monitor **50** and ICD **60**, which may be subcutaneously implanted devices. It is recognized that all of the IMDs **12**, **14**, **16**, **50** and **60** may not be implanted in a single patient **6**. Rather, the various intracardiac pacemakers **12**, **14** and **16** and the extracardiac ECG monitor **50** and ICD **60** are shown to illustrate the various types of implantable devices that may be implanted to monitor a patient's heart **8** and/or deliver one or more therapies to heart **8**.

ECG monitor **50** includes housing-based electrodes **52** for sensing a subcutaneous ECG signal for use in diagnosing a

cardiac condition. ECG monitor **50** may correspond to the REVEAL® Insertable Loop Recorder, available from Medtronic, Inc., Minneapolis, Minn.

ICD **60** is shown coupled to a subcutaneous lead **70** which may carry sensing electrodes **72** and **76** for detecting tachyarrhythmias of heart **8** and a defibrillation electrode **74** for delivering high voltage cardioversion/defibrillation shock pulses to heart **8** in response to detecting tachycardia or fibrillation. ICD **60** and lead **70** may correspond to a subcutaneous ICD and lead system as generally disclosed in U.S. patent application Ser. No. 14/198,058 (Olson), hereby incorporated herein by reference in its entirety, or the above-incorporated '785 patent (Crutchfield). In other examples, ICD **60** may be coupled to a substernal, transvenous or other lead and electrode configuration.

Each of pacemakers **12**, **14** and **16** include a control module capable of self-configuring an operating mode, in a solo, duo or trio operating mode, to establish available pacing modes, monitoring functions and associated programmable parameters of the pacemaker **12**, **14** or **16** in response to establishing the presence of other ones of pacemaker **12**, **14** or **16** as generally described in conjunction with FIG. 4 above. In addition, the control modules of each of pacemakers **12**, **14** and **16** may be configured to modify a currently configured solo, duo or trio operating mode in response to establishing the presence of another implantable medical device besides an intracardiac pacemaker.

For example, RA pacemaker **12** may be capable of configuring itself in a solo operating mode, a modified solo operating mode in the presence of ICD **60**, and a modified solo operating mode in the presence of ECG monitor **50**. RA pacemaker **12** may be further capable of self-configuring a duo operating mode when the presence of a ventricular intracardiac pacemaker (RV or LV pacemaker **14** or **16**) is present, a modified duo mode when a ventricular pacemaker **14** or **16** is present and ICD **60** is present and a modified duo mode when ventricular pacemaker **14** or **16** is present and ECG monitor **50** is present, and so on.

With each IMD added to the system **10** implanted in patient **6**, the RA pacemaker **12** may establish an existing solo, duo or trio operating mode based on whether another pacemaker **14** or **16** is present and modify the established solo, duo or trio mode based on the presence of another IMD **50** or **60**. A currently configured operating mode is modified when an IMD other than an intracardiac pacemaker is implanted by enabling or disabling a feature, adjusting a therapy delivery or monitoring control parameter, or enabling programmability of a control parameter by a user interacting with an external device **20**. The operating mode is modified to disable functions that may be redundant between an intracardiac pacemaker **12**, **14** or **16** and an extracardiac IMD **50** or **60** to conserve battery energy in the intracardiac pacemaker. The operating mode may additionally or alternatively be modified to add features which take advantage of the presence of an extracardiac, e.g., a subcutaneously implanted, IMD.

For example, RA pacemaker **12** may enable AV block monitoring in a solo operating mode for detecting a need for RV pacemaker **14** due to development of AV conduction block. AV block monitoring by RA pacemaker **12** may be disabled in a modified solo operating mode when ECG monitor **50** is present. ECG monitor **50** may be capable of collecting the data needed for monitoring AV block for determining a need for an RV pacemaker **14**. Disabling AV block monitoring in RA pacemaker **12** during the solo mode will conserve battery life of the RA pacemaker **12**.

In another example, a ventricular intracardiac pacemaker **14** or **16** may self-configure a duo operating mode for delivering DDD(R) pacing in conjunction with RA pacemaker **12** as described above. In one example, if both RV pacemaker and LV pacemaker are present with RA pacemaker **12**, RV pacemaker may be self-configured in a trio operating mode that includes only right ventricular back up pacing, e.g., in a VVI mode. LV pacemaker **16** may be self-configured in a trio operating mode that includes VVI (R) and VDD(R) programmable pacing modes to provide atrial-synchronized LV pacing, with the RV pacemaker providing only back up RV pacing.

If ICD **60** is present, the ventricular pacemaker **14** or **16** may modify its self-configured operating mode to add ventricular tachycardia (VT) detection and ventricular ATP therapy delivery. For example, VT detection and ventricular ATP therapy may be available in the solo, duo or trio mode with FF atrial event sensing enabled since it may be desirable to discriminate VT from supraventricular tachycardia (SVT) using FF atrial sensed events. Ventricular ATP may be undesirable without the capability of cardioversion or defibrillation shock therapy provided by ICD **60** since VT could accelerate or deteriorate into ventricular fibrillation (VF).

As such, a modified solo, duo or trio operating mode of RV pacemaker **14** or LV pacemaker **16** may add ventricular ATP or other therapies that the intracardiac pacemaker **14** or **16** is capable of delivering but is not normally enabled to do so when ICD **60** is not present due to patient safety or other concerns. Various examples of VT detection and ATP therapies that may be implemented in a ventricular intracardiac pacemaker **14** or **16** are generally disclosed in commonly-assigned U.S. Pat. No. 7,515,960 (Sharma), U.S. Pat. No. 7,149,577 (Sharma, et al.), U.S. Pat. No. 7,623,911 (Sarkar, et al.), U.S. Pat. No. 7,742,812 (Ghanem, et al.), and U.S. Pat. No. 8,401,629 (Stadler, et al.), all of which patents are hereby incorporated herein by reference in their entirety.

Any of the intracardiac pacemakers **12**, **14** or **16** may establish the presence of an extracardiac IMD **50** or **60** in response to an RF telemetry notification signal received from external device **20**. Alternatively, intracardiac pacemakers **12**, **14** or **16** may be configured to receive a communication signal from an extracardiac IMD **50** or **60** by an ultrasonic body bus communication signal as generally disclosed in U.S. Pat. No. 5,113,859 (Funke), hereby incorporated herein by reference in its entirety.

Thus, various examples of an implantable medical device system have been described according to illustrative embodiments. However, one of ordinary skill in the art will appreciate that various modifications may be made to the described embodiments without departing from the scope of the following claims.

The invention claimed is:

1. A medical device system, comprising

a first implantable pacemaker comprising a housing and a pair of electrodes, the housing and the pair of electrodes configured to be implanted in a first heart chamber; and a second implantable pacemaker configured to be implanted in a second heart chamber different than the first heart chamber;

the first implantable pacemaker further comprising:

a first sensing module within the housing, the first sensing module configured to receive a cardiac electrical signal via the pair of electrodes and sense from the cardiac electrical signal near field intrinsic cardiac events occurring in the first heart chamber, far field intrinsic events occurring in the second heart chamber different than the first heart chamber, and far field pacing pulses,

31

the far field pacing pulses being pacing pulses delivered in the second heart chamber by the second implantable pacemaker;

a first pulse generator within the housing, the first pulse generator coupled to the pair electrodes for delivering a cardiac pacing pulse to the first heart chamber; and a first control module within the housing, the first control module configured to:

set a first pacing escape interval in response to a far field pacing pulse sensed by the first sensing module; permit the first pacing escape interval to continue without restarting the first pacing escape interval in response to a far field intrinsic event sensed by the first sensing module during the first pacing escape interval; and

control the pulse generator to deliver the cardiac pacing pulse to the first heart chamber upon expiration of the first pacing escape interval.

2. The system of claim 1, wherein the first control module is further configured to set a second pacing escape interval different than the first pacing escape interval in response to a far field intrinsic event sensed by the first sensing module outside the first pacing escape interval.

3. The system of claim 2, wherein the first control module is configured to:

detect a tachycardia of the second heart chamber in response to the far-field intrinsic events sensed by the first sensing module; and disable setting the first and second escape intervals in response to detecting the tachycardia.

4. The system of claim 3, wherein the first control module is configured to detect the tachycardia by detecting a decrease in a rate of the far-field intrinsic events sensed by the first sensing module below a predetermined minimum rate.

5. The system of claim 3, wherein the first control module is configured to detect the tachycardia by detecting an increase of the far-field intrinsic events sensed by the first sensing module, the increase being above a predetermined pacing mode switch threshold.

6. The system of claim 2, wherein the first control module is further configured to:

start an extended first pacing escape interval in response to a next far field pacing pulse event sensed by the first sensing module;

determine a conduction time from the next far field pacing pulse event to a next near field intrinsic event sensed during the extended first pacing escape interval;

compare the conduction time to a conduction time range; and

responsive to the conduction time being within the conduction time range, set a back-up pacing interval in response to each one of a plurality of subsequent far field pacing pulse events, the back-up pacing interval being greater than the first pacing escape interval.

7. The system of claim 6, wherein the control module is further configured to:

control the pulse generator to deliver a back-up pacing pulse to the first heart chamber upon expiration of the back-up pacing interval; and

set the first pacing escape interval in response to a far field pacing pulse event sensed by the first sensing module after the back-up pacing pulse.

8. The system of claim 1, wherein the second implantable pacemaker comprises:

a second housing;

32

a second pair of electrodes, wherein the second housing and the second pair of electrodes are configured to be implanted in the second heart chamber;

a second sensing module within the second housing, the second sensing module configured to receive a second cardiac electrical signal via the second pair of electrodes and sense from the second cardiac electrical signal second far field pacing pulse events that are first pacing pulses delivered in the first heart chamber by the first implantable pacemaker;

a second pulse generator within the second housing, the second pulse generator coupled to the second pair of electrodes for delivering second cardiac pacing pulses to the second heart chamber; and

a second control module within the second housing, the second control module configured to:

set a first pacing pulse output for controlling the second cardiac pacing pulses that are delivered to the second heart chamber in response to not sensing the second far field pacing pulse events by the second sensing module; and

set a second pacing pulse output for controlling the second cardiac pacing pulses that are delivered to the second heart chamber in response to sensing the second far field pacing pulse events by the second sensing module, the second pacing pulse output greater than the first pacing pulse output.

9. The system of claim 8, wherein the second control module is configured to:

set the first pacing pulse output by setting a first pacing safety margin; and

set the second pacing pulse output by setting a second pacing safety margin greater than the first pacing safety margin.

10. The system of claim 1, wherein:

the first control module is configured to set a blanking interval in response to the far field pacing pulse, the blanking interval set to expire prior to an expected far field evoked response event;

the first sensing module is configured to sense a far field evoked response following the blanking interval; and the first control module is configured to set the first pacing escape interval in response to the far field pacing pulse by starting the first pacing escape interval upon the far field evoked response sensed after the blanking interval.

11. A method performed by an implantable medical device system including a first implantable pacemaker having a housing, the implantable medical device system further including a second implantable pacemaker, wherein the method comprises:

sensing from a cardiac electrical signal received by a first sensing module within the housing of the first implantable pacemaker: near field intrinsic cardiac events occurring in a first heart chamber, far field intrinsic events occurring in a second heart chamber different than the first heart chamber, and far field pacing pulses, the far field pacing pulses being pacing pulses delivered in the second heart chamber by the second implantable pacemaker, wherein the housing of the first implantable pacemaker is configured to be implanted within the first heart chamber and the second implantable pacemaker is configured to be implanted within the second heart chamber;

setting a first pacing escape interval in response to a far field pacing pulse sensed by the first sensing module;

allowing the first pacing escape interval to continue without restarting the first pacing escape interval in response to a far field intrinsic event sensed by the first sensing module during the first pacing escape interval; and

controlling a pulse generator within the housing of the first implantable pacemaker to deliver a cardiac pacing pulse to the first heart chamber upon expiration of the first pacing escape interval.

12. The method of claim 11, further comprising setting a second pacing escape interval different than the first pacing escape interval in response to a far field intrinsic event sensed by the first sensing module outside the first pacing escape interval.

13. The method of claim 12, further comprising: detecting a tachycardia of the second heart chamber in response to the far-field intrinsic events sensed by the first sensing module; and disabling setting the first and second escape intervals in response to detecting the tachycardia.

14. The method of claim 13, wherein detecting the tachycardia comprises detecting a decrease in a rate of the far-field intrinsic events sensed by the first sensing module below a predetermined minimum rate.

15. The method of claim 13, wherein detecting the tachycardia comprises detecting an increase of the far-field intrinsic events sensed by the first sensing module above a predetermined pacing mode switch threshold.

16. The method of claim 12, further comprising: starting an extended first pacing escape interval in response to a next far field pacing pulse event sensed by the first sensing module;

determining a conduction time from the next far field pacing pulse event to a next near field intrinsic event sensed during the extended first pacing escape interval; comparing the conduction time to a conduction time range; and

responsive to the conduction time being within the conduction time range, setting a back-up pacing interval in response to each one of a plurality of subsequent far field pacing pulse events, the back-up pacing interval being greater than the first pacing escape interval.

17. The method of claim 16, further comprising: controlling the pulse generator to deliver a back-up pacing pulse to the first heart chamber upon expiration of the back-up pacing interval; and

setting the first pacing escape interval in response to a far field pacing pulse event sensed by the first sensing module after the back-up pacing pulse.

18. The method of claim 11, further comprising: sensing, from a second cardiac electrical signal received by a second sensing module within a second housing of the second implantable pacemaker, second far field pacing pulse events that are pacing pulses delivered in the first heart chamber by the first implantable pacemaker, wherein the second housing of the second implantable pacemaker is configured to be implanted within the second heart chamber;

setting a first pacing pulse output for controlling second cardiac pacing pulses that are delivered to the second heart chamber, the first pacing pulse output set in response to not sensing the second far field pacing pulse events by the second sensing module; and

setting a second pacing pulse output for controlling the second cardiac pacing pulses that are delivered to the second heart chamber, the second pacing pulse output set in response to sensing the second far field pacing pulse events by the second sensing module, the second pacing pulse output greater than the first pacing pulse output.

19. The method of claim 18, further comprising: setting the first pacing pulse output by setting a first pacing safety margin; and setting the second pacing pulse output by setting a second pacing safety margin greater than the first pacing safety margin.

20. The method of claim 11, wherein setting the first pacing escape interval in response to the far field pacing pulse comprises:

setting a blanking interval in response to the far field pacing pulse, the blanking interval set to expire prior to an expected far field evoked response event;

sensing a far field evoked response following the blanking interval; and

starting the first pacing escape interval upon sensing the far field evoked response after the blanking interval.

21. A non-transitory, computer-readable storage medium storing a set of instructions that, when executed by a control module within a housing of a first implantable pacemaker of a medical device system including the first implantable pacemaker and a second implantable pacemaker, cause the system to:

sense from a cardiac electrical signal received by a first sensing module of the first implantable pacemaker near field intrinsic cardiac events occurring in a first heart chamber, far field intrinsic events occurring in a second heart chamber different than the first heart chamber, and far field pacing pulses, the far field pacing pulses being pacing pulses delivered in the second heart chamber by the second implantable pacemaker, wherein the housing of the first implantable pacemaker is configured to be implanted within the first heart chamber and the second implantable pacemaker is configured to be implanted within the second heart chamber;

setting a first pacing escape interval in response to a far field pacing pulse sensed by the first sensing module;

allowing the first pacing escape interval to continue without restarting the first pacing escape interval in response to a far field intrinsic event sensed by the sensing module during the first pacing escape interval; and

controlling a pulse generator within the housing of the first implantable pacemaker to deliver a cardiac pacing pulse to the first heart chamber upon expiration of the first pacing escape interval.

\* \* \* \* \*

专利名称(译)	多腔心内起搏系统		
公开(公告)号	<a href="#">US10441796</a>	公开(公告)日	2019-10-15
申请号	US14/644878	申请日	2015-03-11
[标]申请(专利权)人(译)	美敦力公司		
申请(专利权)人(译)	美敦力公司, INC.		
当前申请(专利权)人(译)	美敦力公司, INC.		
[标]发明人	DEMME WADE M SHELDON TODD J GREENHUT SAUL E REINKE JAMES D		
发明人	DEMME, WADE M SHELDON, TODD J GREENHUT, SAUL E REINKE, JAMES D		
IPC分类号	A61N1/37 A61N1/365 A61N1/375 A61B5/0464 A61B5/00 A61N1/36 A61N1/362 A61N1/372 A61B5/0402		
CPC分类号	A61B5/0452 A61B5/0464 A61B5/4836 A61B5/686 A61N1/36 A61N1/3622 A61N1/36592 A61N1/3682 A61N1/3688 A61N1/3706 A61N1/37205 A61N1/3756 A61B5/0402		
其他公开文献	US20160015984A1		
外部链接	<a href="#">Espacenet</a>		

摘要(译)

包括在包括第一起搏器和第二起搏器的可植入医疗设备系统中的第一起搏器的控制模块被配置为响应于由第一起搏器感测到的远场起搏脉冲来设置起搏逃逸间隔。远场起搏脉冲是第二起搏器传递的起搏脉冲。响应于第一起搏器在起搏逃逸间隔期间感测到的远场固有事件, 允许起搏逃逸间隔持续而不重新启动。第一起搏器在起搏逃逸间隔到期时向心脏传递心脏起搏脉冲。

