



US010022538B2

(12) **United States Patent**  
**Drasler et al.**

(10) **Patent No.:** **US 10,022,538 B2**  
(45) **Date of Patent:** **Jul. 17, 2018**

(54) **CARDIAC STIMULATION SYSTEM**

(71) Applicant: **Boston Scientific Scimed, Inc.**, Maple Grove, MN (US)

(72) Inventors: **William J. Drasler**, Minnetonka, MN (US); **Michael J. Pikus**, Golden Valley, MN (US); **Roger Hastings**, Maple Grove, MN (US); **Scott R. Smith**, Chaska, MN (US); **Daniel M. Lafontaine**, Plymouth, MN (US); **Douglas R. Saholt**, Mound, MN (US); **Graig L. Kveen**, Maple Grove, MN (US); **Martin R. Willard**, Burnsville, MN (US)

(73) Assignee: **Boston Scientific Scimed, Inc.**, Maple Grove, MN (US)

(\* ) Notice: Subject to any disclaimer, the term of this patent is extended or adjusted under 35 U.S.C. 154(b) by 0 days.

(21) Appl. No.: **14/044,094**

(22) Filed: **Oct. 2, 2013**

(65) **Prior Publication Data**

US 2014/0039591 A1 Feb. 6, 2014

**Related U.S. Application Data**

(63) Continuation of application No. 11/549,352, filed on Oct. 13, 2006, now abandoned.  
(Continued)

(51) **Int. Cl.**  
*A61N 1/05* (2006.01)  
*A61B 5/00* (2006.01)  
(Continued)

(52) **U.S. Cl.**  
CPC ..... *A61N 1/059* (2013.01); *A61B 5/6848* (2013.01); *A61B 5/6882* (2013.01);  
(Continued)

(58) **Field of Classification Search**

CPC ..... A61N 1/0587; A61N 1/375  
(Continued)

(56) **References Cited**

U.S. PATENT DOCUMENTS

3,057,356 A 10/1962 Greatbatch  
3,357,434 A 12/1967 Abel  
(Continued)

FOREIGN PATENT DOCUMENTS

EP 0758542 A1 2/1997  
EP 1166820 A2 1/2002  
(Continued)

OTHER PUBLICATIONS

"U.S. Appl. No. 10/971,550, Non Final Office Action dated Mar. 19, 2007", 11 pgs.

(Continued)

*Primary Examiner* — Carl H Layno

*Assistant Examiner* — Jennifer Ghand

(74) *Attorney, Agent, or Firm* — Seager, Tuft & Wickhem LLP

(57) **ABSTRACT**

Some embodiments of pacing systems employ wireless electrode assemblies to provide pacing therapy. The wireless electrode assemblies may wirelessly receive energy via an inductive coupling so as to provide electrical stimulation to the surrounding heart tissue. In certain embodiments, the wireless electrode assembly may include one or more biased tines that shift from a first position to a second position to secure the wireless electrode assembly into the inner wall of the heart chamber.

**18 Claims, 4 Drawing Sheets**

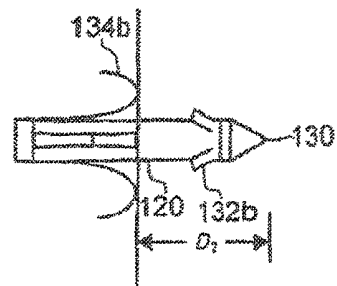
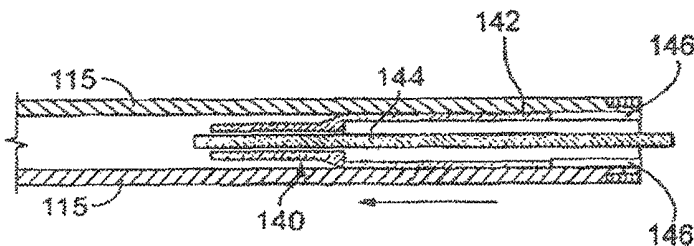

**Related U.S. Application Data**

- (60) Provisional application No. 60/748,964, filed on Dec. 9, 2005.
- (51) **Int. Cl.**  
*A61B 5/042* (2006.01)  
*A61N 1/368* (2006.01)  
*A61N 1/372* (2006.01)  
*A61N 1/375* (2006.01)
- (52) **U.S. Cl.**  
 CPC ..... *A61N 1/0573* (2013.01); *A61B 5/0031* (2013.01); *A61B 5/042* (2013.01); *A61N 1/3684* (2013.01); *A61N 1/3756* (2013.01); *A61N 1/37205* (2013.01)
- (58) **Field of Classification Search**  
 USPC ..... 607/33, 36, 126  
 See application file for complete search history.

|           |    |         |                      |
|-----------|----|---------|----------------------|
| 5,383,915 | A  | 1/1995  | Adams                |
| 5,383,924 | A  | 1/1995  | Brehier              |
| 5,405,367 | A  | 4/1995  | Schulman et al.      |
| 5,411,535 | A  | 5/1995  | Fujii et al.         |
| 5,411,537 | A  | 5/1995  | Munshi et al.        |
| 5,447,533 | A  | 9/1995  | Vachon et al.        |
| 5,487,760 | A  | 1/1996  | Villafana            |
| 5,531,780 | A  | 7/1996  | Vachon               |
| 5,571,148 | A  | 11/1996 | Loeb et al.          |
| 5,591,217 | A  | 1/1997  | Barreras             |
| 5,622,168 | A  | 4/1997  | Keusch et al.        |
| 5,624,316 | A  | 4/1997  | Roskowski et al.     |
| 5,628,778 | A  | 5/1997  | Kruse et al.         |
| 5,674,259 | A  | 10/1997 | Gray                 |
| 5,735,887 | A  | 4/1998  | Barreras, Sr. et al. |
| 5,755,764 | A  | 5/1998  | Schroepffel          |
| 5,769,877 | A  | 6/1998  | Barreras, Sr.        |
| 5,772,693 | A  | 6/1998  | Brownlee             |
| 5,775,331 | A  | 7/1998  | Raymond et al.       |
| 5,779,715 | A  | 7/1998  | Tu                   |
| 5,792,208 | A  | 8/1998  | Gray                 |
| 5,800,535 | A  | 9/1998  | Howard, III          |
| 5,807,397 | A  | 9/1998  | Barreras             |
| 5,814,089 | A  | 9/1998  | Stokes et al.        |
| 5,833,715 | A  | 11/1998 | Vachon et al.        |
| 5,851,227 | A  | 12/1998 | Spehr                |
| 5,861,019 | A  | 1/1999  | Sun et al.           |
| 5,871,532 | A  | 2/1999  | Schroepffel          |
| 5,876,429 | A  | 3/1999  | Schroepffel          |
| 5,876,431 | A  | 3/1999  | Spehr et al.         |
| 5,954,757 | A  | 9/1999  | Gray                 |
| 5,995,876 | A  | 11/1999 | Kruse et al.         |
| 6,006,139 | A  | 12/1999 | Kruse et al.         |
| 6,035,239 | A  | 3/2000  | Patag et al.         |
| 6,041,258 | A  | 3/2000  | Cigaina et al.       |
| 6,044,300 | A  | 3/2000  | Gray                 |
| 6,053,873 | A  | 4/2000  | Govari et al.        |
| 6,115,636 | A  | 9/2000  | Ryan                 |
| 6,123,724 | A  | 9/2000  | Denker               |
| 6,132,456 | A  | 10/2000 | Sommer et al.        |
| 6,141,588 | A  | 10/2000 | Cox et al.           |
| 6,141,591 | A  | 10/2000 | Lenarz et al.        |
| 6,144,879 | A  | 11/2000 | Gray                 |
| 6,144,880 | A  | 11/2000 | Ding et al.          |
| 6,161,029 | A  | 12/2000 | Spreigl et al.       |
| 6,164,284 | A  | 12/2000 | Schulman et al.      |
| 6,200,303 | B1 | 3/2001  | Verrior et al.       |
| 6,208,894 | B1 | 3/2001  | Schulman et al.      |
| 6,223,079 | B1 | 4/2001  | Bakels et al.        |
| 6,240,316 | B1 | 5/2001  | Richmond et al.      |
| 6,266,567 | B1 | 7/2001  | Ishikawa et al.      |
| 6,315,721 | B2 | 11/2001 | Schulman et al.      |
| 6,317,615 | B1 | 11/2001 | KenKnight et al.     |
| 6,322,559 | B1 | 11/2001 | Daulton et al.       |
| 6,336,937 | B1 | 1/2002  | Vonesh et al.        |
| 6,345,202 | B2 | 2/2002  | Richmond et al.      |
| 6,351,673 | B1 | 2/2002  | Ding et al.          |
| 6,360,127 | B1 | 3/2002  | Ding et al.          |
| 6,363,279 | B1 | 3/2002  | Ben-Haim et al.      |
| 6,363,938 | B2 | 4/2002  | Saadat et al.        |
| 6,370,434 | B1 | 4/2002  | Zhang et al.         |
| 6,381,495 | B1 | 4/2002  | Jenkins              |
| 6,385,472 | B1 | 5/2002  | Hall et al.          |
| 6,409,674 | B1 | 6/2002  | Brockway et al.      |
| 6,441,747 | B1 | 8/2002  | Khair et al.         |
| 6,442,413 | B1 | 8/2002  | Silver               |
| 6,445,953 | B1 | 9/2002  | Bulkes et al.        |
| 6,456,256 | B1 | 9/2002  | Amundson et al.      |
| 6,501,983 | B1 | 12/2002 | Natarajan et al.     |
| 6,510,345 | B1 | 1/2003  | Van et al.           |
| 6,522,926 | B1 | 2/2003  | Kieval et al.        |
| 6,542,775 | B2 | 4/2003  | Ding et al.          |
| 6,556,874 | B2 | 4/2003  | Audoglio             |
| 6,564,807 | B1 | 5/2003  | Schulman et al.      |
| 6,571,127 | B1 | 5/2003  | Ben-Haim et al.      |
| 6,574,510 | B2 | 6/2003  | Von Arx et al.       |
| 6,582,441 | B1 | 6/2003  | He et al.            |
| 6,589,230 | B2 | 7/2003  | Gia et al.           |
| 6,614,406 | B2 | 9/2003  | Amundson et al.      |

(56) **References Cited**

U.S. PATENT DOCUMENTS

|           |   |         |                            |
|-----------|---|---------|----------------------------|
| 3,596,662 | A | 8/1971  | Bolduc                     |
| 3,667,477 | A | 6/1972  | Susset et al.              |
| 3,713,449 | A | 1/1973  | Mulier                     |
| 3,727,616 | A | 4/1973  | Lenzkes                    |
| 3,835,864 | A | 9/1974  | Razor et al.               |
| 3,902,501 | A | 9/1975  | Citron et al.              |
| 3,942,535 | A | 3/1976  | Schulman                   |
| 3,943,936 | A | 3/1976  | Razor et al.               |
| 4,010,756 | A | 3/1977  | DuMont et al.              |
| 4,157,720 | A | 6/1979  | Greatbatch                 |
| 4,162,679 | A | 7/1979  | Reenstierna                |
| 4,198,991 | A | 4/1980  | Harris                     |
| 4,256,115 | A | 3/1981  | Bilitch                    |
| 4,441,210 | A | 4/1984  | Hochmair et al.            |
| 4,525,774 | A | 6/1985  | Kino et al.                |
| 4,543,955 | A | 10/1985 | Schroepffel                |
| 4,641,664 | A | 2/1987  | Botvidsson                 |
| 4,644,957 | A | 2/1987  | Ricciardelli               |
| 4,681,111 | A | 7/1987  | Silvian                    |
| 4,721,118 | A | 1/1988  | Harris                     |
| 4,830,006 | A | 5/1989  | Haluska et al.             |
| 4,858,623 | A | 8/1989  | Bradshaw et al.            |
| 4,860,750 | A | 8/1989  | Frey et al.                |
| 4,913,164 | A | 4/1990  | Greene et al. .... 607/126 |
| 4,953,564 | A | 9/1990  | Berthelsen                 |
| 4,987,897 | A | 1/1991  | Funke                      |
| 5,012,806 | A | 5/1991  | De Bellis                  |
| 5,078,736 | A | 1/1992  | Behl                       |
| 5,113,869 | A | 5/1992  | Nappholz et al.            |
| 5,139,033 | A | 8/1992  | Everett et al.             |
| 5,143,090 | A | 9/1992  | Dutcher et al.             |
| 5,170,802 | A | 12/1992 | Mehra                      |
| 5,178,149 | A | 1/1993  | Imburgia et al.            |
| 5,193,539 | A | 3/1993  | Schulman et al.            |
| 5,193,540 | A | 3/1993  | Schulman et al.            |
| 5,234,437 | A | 8/1993  | Sepetka                    |
| 5,243,977 | A | 9/1993  | Trabucco et al.            |
| 5,246,014 | A | 9/1993  | Williams et al.            |
| 5,250,071 | A | 10/1993 | Palermo                    |
| 5,255,693 | A | 10/1993 | Dutcher et al.             |
| 5,261,916 | A | 11/1993 | Engelson                   |
| 5,300,107 | A | 4/1994  | Stokes et al.              |
| 5,304,195 | A | 4/1994  | Twyford, Jr. et al.        |
| 5,312,415 | A | 5/1994  | Palermo                    |
| 5,312,439 | A | 5/1994  | Loeb                       |
| 5,314,458 | A | 5/1994  | Najafi et al.              |
| 5,324,316 | A | 6/1994  | Schulman et al.            |
| 5,324,325 | A | 6/1994  | Moaddeb                    |
| 5,335,664 | A | 8/1994  | Nagashima                  |
| 5,336,252 | A | 8/1994  | Cohen                      |
| 5,342,408 | A | 8/1994  | deCoriolis et al.          |
| 5,350,397 | A | 9/1994  | Palermo et al.             |

(56)

References Cited

U.S. PATENT DOCUMENTS

|                 |         |                    |                  |         |                       |                           |
|-----------------|---------|--------------------|------------------|---------|-----------------------|---------------------------|
| 6,647,291 B1    | 11/2003 | Bonner et al.      | 2002/0065543 A1  | 5/2002  | Gomperz et al.        |                           |
| 6,647,292 B1    | 11/2003 | Bardy et al.       | 2002/0077556 A1  | 6/2002  | Schwartz              |                           |
| 6,783,499 B2    | 8/2004  | Schwartz           | 2002/0077685 A1  | 6/2002  | Sundquist et al.      |                           |
| 6,856,836 B2    | 2/2005  | Ding et al.        | 2002/0123774 A1  | 9/2002  | Loeb et al.           |                           |
| 6,859,665 B2    | 2/2005  | Ding et al.        | 2002/0123785 A1  | 9/2002  | Youngxing et al.      |                           |
| 6,895,265 B2    | 5/2005  | Silver             | 2002/0128546 A1  | 9/2002  | Silver                |                           |
| 6,895,280 B2    | 5/2005  | Meadows et al.     | 2002/0138009 A1  | 9/2002  | Brockway et al.       |                           |
| 6,897,788 B2    | 5/2005  | Khair et al.       | 2002/0138100 A1  | 9/2002  | Stoll et al.          |                           |
| 6,901,294 B1    | 5/2005  | Whitehurst et al.  | 2002/0183791 A1  | 12/2002 | Denker et al.         |                           |
| 6,907,285 B2    | 6/2005  | Denker et al.      | 2002/0188323 A1  | 12/2002 | Penner et al.         |                           |
| 6,917,833 B2    | 7/2005  | Denker et al.      | 2002/0198604 A1  | 12/2002 | Schulman et al.       |                           |
| 6,947,792 B2    | 9/2005  | Ben-Haim et al.    | 2003/0036773 A1  | 2/2003  | Whitehurst et al.     |                           |
| 6,970,742 B2    | 11/2005 | Mann et al.        | 2003/0050681 A1  | 3/2003  | Pianca et al.         |                           |
| 6,978,173 B2    | 12/2005 | Stoll et al.       | 2003/0050685 A1* | 3/2003  | Nikolic .....         | A61B 17/12022<br>623/1.11 |
| 7,003,350 B2    | 2/2006  | Denker et al.      | 2003/0055465 A1  | 3/2003  | Ben-Haim et al.       |                           |
| 7,006,864 B2    | 2/2006  | Echt et al.        | 2003/0055466 A1  | 3/2003  | Ben-Haim et al.       |                           |
| 7,050,849 B2    | 5/2006  | Echt et al.        | 2003/0055467 A1  | 3/2003  | Ben-Haim et al.       |                           |
| 7,054,691 B1    | 5/2006  | Kuzma et al.       | 2003/0074041 A1  | 4/2003  | Parry et al.          |                           |
| 7,062,318 B2    | 6/2006  | Ben-Haim et al.    | 2003/0088278 A1  | 5/2003  | Bardy et al.          |                           |
| 7,076,305 B2    | 7/2006  | Imran et al.       | 2003/0109914 A1  | 6/2003  | Westlund et al.       |                           |
| 7,184,830 B2    | 2/2007  | Echt et al.        | 2003/0114735 A1  | 6/2003  | Silver et al.         |                           |
| 7,200,437 B1    | 4/2007  | Nabutovsky et al.  | 2003/0114742 A1  | 6/2003  | Lewkowicz et al.      |                           |
| 7,209,783 B2    | 4/2007  | Fellows et al.     | 2003/0130571 A1* | 7/2003  | Lattouf .....         | A61B 17/00234<br>600/374  |
| 7,231,260 B2    | 6/2007  | Wallace et al.     | 2003/0158584 A1  | 8/2003  | Cates et al.          |                           |
| 7,289,853 B1    | 10/2007 | Campbell et al.    | 2003/0181958 A1  | 9/2003  | Dobak                 |                           |
| 7,410,497 B2    | 8/2008  | Hastings et al.    | 2003/0181959 A1  | 9/2003  | Dobak                 |                           |
| 7,522,962 B1    | 4/2009  | Doron et al.       | 2003/0204206 A1  | 10/2003 | Padua et al.          |                           |
| 7,532,932 B2    | 5/2009  | Denker et al.      | 2003/0216729 A1  | 11/2003 | Marchitto et al.      |                           |
| 7,532,933 B2    | 5/2009  | Hastings et al.    | 2003/0236518 A1  | 12/2003 | Marchitto et al.      |                           |
| 7,558,631 B2    | 7/2009  | Cowan et al.       | 2004/0019364 A1  | 1/2004  | Kieval et al.         |                           |
| 7,565,195 B1    | 7/2009  | Kroll et al.       | 2004/0059280 A1  | 3/2004  | Makower et al.        |                           |
| 7,606,621 B2    | 10/2009 | Brisken et al.     | 2004/0059392 A1  | 3/2004  | Parramon et al.       |                           |
| 7,610,092 B2    | 10/2009 | Cowan et al.       | 2004/0073267 A1  | 4/2004  | Holzer                |                           |
| 7,615,010 B1    | 11/2009 | Najafi et al.      | 2004/0087831 A1  | 5/2004  | Michels et al.        |                           |
| 7,634,313 B1    | 12/2009 | Kroll et al.       | 2004/0097805 A1  | 5/2004  | Verard et al.         |                           |
| 7,647,109 B2    | 1/2010  | Hastings et al.    | 2004/0098068 A1  | 5/2004  | Carbunaru et al.      |                           |
| 7,650,186 B2    | 1/2010  | Hastings et al.    | 2004/0102830 A1* | 5/2004  | Williams .....        | 607/125                   |
| 7,702,392 B2    | 4/2010  | Echt et al.        | 2004/0103906 A1  | 6/2004  | Schulman et al.       |                           |
| 7,765,001 B2    | 7/2010  | Echt et al.        | 2004/0106954 A1  | 6/2004  | Whitehurst et al.     |                           |
| 7,809,438 B2    | 10/2010 | Echt et al.        | 2004/0127895 A1  | 7/2004  | Flock et al.          |                           |
| 7,840,281 B2    | 11/2010 | Kveen et al.       | 2004/0147969 A1  | 7/2004  | Mann et al.           |                           |
| 7,848,815 B2    | 12/2010 | Brisken et al.     | 2004/0147973 A1  | 7/2004  | Hauser et al.         |                           |
| 7,848,823 B2    | 12/2010 | Drasler et al.     | 2004/0167580 A1  | 8/2004  | Mann et al.           |                           |
| 7,877,136 B1    | 1/2011  | Moffitt et al.     | 2004/0171355 A1  | 9/2004  | Yu et al.             |                           |
| 7,877,142 B2    | 1/2011  | Moaddeb et al.     | 2004/0172083 A1  | 9/2004  | Penner                |                           |
| 7,890,173 B2    | 2/2011  | Brisken et al.     | 2004/0176672 A1  | 9/2004  | Silver et al.         |                           |
| 7,894,904 B2    | 2/2011  | Cowan et al.       | 2004/0176822 A1  | 9/2004  | Thompson et al.       |                           |
| 7,894,907 B2    | 2/2011  | Cowan et al.       | 2004/0193092 A1  | 9/2004  | Deal                  |                           |
| 7,894,910 B2    | 2/2011  | Cowan et al.       | 2004/0193229 A1  | 9/2004  | Starkebaum et al.     |                           |
| 7,899,537 B1    | 3/2011  | Kroll et al.       | 2004/0210282 A1  | 10/2004 | Flock et al.          |                           |
| 7,899,541 B2    | 3/2011  | Cowan et al.       | 2004/0215092 A1  | 10/2004 | Fischell et al.       |                           |
| 7,899,542 B2    | 3/2011  | Cowan et al.       | 2004/0215280 A1  | 10/2004 | Dublin et al.         |                           |
| 7,904,170 B2    | 3/2011  | Harding            | 2004/0230090 A1  | 11/2004 | Hegde et al.          |                           |
| 7,937,148 B2    | 5/2011  | Jacobson           | 2004/0230255 A1  | 11/2004 | Dobak, III            |                           |
| 7,937,161 B2    | 5/2011  | Hastings et al.    | 2005/0021108 A1  | 1/2005  | Klosterman et al.     |                           |
| 7,945,333 B2    | 5/2011  | Jacobson           | 2005/0025797 A1  | 2/2005  | Wang et al.           |                           |
| 7,996,087 B2    | 8/2011  | Cowan et al.       | 2005/0043765 A1  | 2/2005  | Williams et al.       |                           |
| 8,010,209 B2    | 8/2011  | Jacobson           | 2005/0051243 A1  | 3/2005  | Forbes Jones et al.   |                           |
| 8,019,419 B1    | 9/2011  | Panescu et al.     | 2005/0057905 A1  | 3/2005  | He et al.             |                           |
| 8,032,219 B2    | 10/2011 | Neumann et al.     | 2005/0060011 A1  | 3/2005  | Denker et al.         |                           |
| 8,050,774 B2    | 11/2011 | Kveen et al.       | 2005/0065575 A1  | 3/2005  | Dobak                 |                           |
| 8,165,694 B2    | 4/2012  | Carbanaru et al.   | 2005/0065589 A1* | 3/2005  | Schneider et al. .... | 607/126                   |
| 8,185,213 B2    | 5/2012  | Kveen et al.       | 2005/0080346 A1  | 4/2005  | Gianchandani et al.   |                           |
| 8,204,595 B2    | 6/2012  | Pianca et al.      | 2005/0080459 A1  | 4/2005  | Jacobson et al.       |                           |
| 8,204,605 B2    | 6/2012  | Hastings et al.    | 2005/0095197 A1  | 5/2005  | Tuszynski et al.      |                           |
| 8,260,416 B2    | 9/2012  | Ben-Haim et al.    | 2005/0096702 A1  | 5/2005  | Denker et al.         |                           |
| 8,290,600 B2    | 10/2012 | Hastings et al.    | 2005/0131511 A1  | 6/2005  | Westlund              |                           |
| 8,332,036 B2    | 12/2012 | Hastings et al.    | 2005/0136385 A1  | 6/2005  | Mann                  |                           |
| 8,340,780 B2    | 12/2012 | Hastings et al.    | 2005/0149138 A1  | 7/2005  | Min et al.            |                           |
| 8,478,408 B2    | 7/2013  | Hastings et al.    | 2005/0165456 A1  | 7/2005  | Mann                  |                           |
| 8,644,934 B2    | 2/2014  | Hastings           | 2005/0182456 A1  | 8/2005  | Ziobro et al.         |                           |
| 2001/0018547 A1 | 8/2001  | Mechlenburg et al. | 2005/0182465 A1  | 8/2005  | Ness                  |                           |
| 2002/0018379 A1 | 2/2002  | Hakuchoh et al.    | 2005/0192637 A1  | 9/2005  | Girouard et al.       |                           |
| 2002/0026228 A1 | 2/2002  | Schauerte          | 2005/0215764 A1  | 9/2005  | Tuszynski et al.      |                           |
| 2002/0052632 A1 | 5/2002  | Ben-Haim et al.    | 2005/0245846 A1  | 11/2005 | Casey                 |                           |
|                 |         |                    | 2005/0251238 A1  | 11/2005 | Wallace et al.        |                           |
|                 |         |                    | 2005/0251240 A1  | 11/2005 | Doan                  |                           |

(56)

## References Cited

## U.S. PATENT DOCUMENTS

2005/0256549 A1 11/2005 Holzer  
 2005/0261741 A1 11/2005 Libbus et al.  
 2005/0273014 A1 12/2005 Gianchandani et al.  
 2005/0288596 A1 12/2005 Eigler  
 2005/0288717 A1 12/2005 Sunagawa  
 2005/0288727 A1 12/2005 Penner  
 2006/0015097 A1 1/2006 Mulier et al.  
 2006/0020316 A1 1/2006 Martinez et al.  
 2006/0064135 A1 3/2006 Brockway  
 2006/0085039 A1 4/2006 Hastings et al.  
 2006/0085041 A1 4/2006 Hastings et al.  
 2006/0085042 A1 4/2006 Hastings et al.  
 2006/0095089 A1 5/2006 Soykan et al.  
 2006/0136001 A1 6/2006 Ortega et al.  
 2006/0136004 A1 6/2006 Cowan et al.  
 2006/0173504 A1 8/2006 Zhu et al.  
 2006/0173505 A1 8/2006 Salo et al.  
 2006/0178719 A1 8/2006 Ideker et al.  
 2006/0206170 A1 9/2006 Denker et al.  
 2006/0241705 A1 10/2006 Neumann et al.  
 2007/0075905 A1 4/2007 Denker et al.  
 2007/0078490 A1 4/2007 Cowan et al.  
 2007/0088394 A1 4/2007 Jacobson  
 2007/0088396 A1 4/2007 Jacobson  
 2007/0088397 A1 4/2007 Jacobson  
 2007/0088398 A1 4/2007 Jacobson  
 2007/0088418 A1 4/2007 Jacobson  
 2007/0106357 A1 5/2007 Denker et al.  
 2007/0135882 A1 6/2007 Drasler et al.  
 2007/0135883 A1 6/2007 Drasler et al.  
 2007/0150009 A1 6/2007 Kveen et al.  
 2007/0150037 A1 6/2007 Hastings et al.  
 2007/0150038 A1 6/2007 Hastings et al.  
 2007/0162079 A1 7/2007 Shemer et al.  
 2007/0203556 A1 8/2007 Rutten et al.  
 2007/0219590 A1 9/2007 Hastings et al.  
 2007/0239248 A1 10/2007 Hastings et al.  
 2007/0276444 A1 11/2007 Gelbart et al.  
 2007/0293904 A1 12/2007 Gelbart et al.  
 2008/0021505 A1 1/2008 Hastings et al.  
 2008/0021532 A1 1/2008 Kveen et al.  
 2008/0039904 A1 2/2008 Bulkes et al.  
 2008/0046040 A1 2/2008 Denker et al.  
 2008/0077184 A1 3/2008 Denker et al.  
 2008/0077188 A1 3/2008 Denker et al.  
 2008/0109054 A1 5/2008 Hastings et al.  
 2008/0119911 A1 5/2008 Rosero  
 2008/0140142 A1 6/2008 Darvish et al.  
 2008/0262588 A1 10/2008 Zarembo et al.  
 2008/0288039 A1 11/2008 Reddy  
 2008/0306359 A1 12/2008 Zdeblick et al.  
 2008/0319502 A1 12/2008 Sunagawa et al.  
 2009/0018599 A1 1/2009 Hastings et al.  
 2009/0082827 A1 3/2009 Kveen et al.  
 2009/0082828 A1 3/2009 Ostroff  
 2009/0088813 A1 4/2009 Brockway et al.  
 2009/0204170 A1 8/2009 Hastings et al.  
 2009/0234407 A1 9/2009 Hastings et al.  
 2009/0275998 A1 11/2009 Burnes et al.  
 2010/0094367 A1 4/2010 Sen  
 2010/0100144 A1 4/2010 Shuros et al.  
 2010/0198288 A1 8/2010 Ostroff  
 2010/0228308 A1 9/2010 Cowan et al.  
 2010/0286744 A1 11/2010 Echt et al.  
 2010/0314775 A1 12/2010 Schwarzbauer  
 2011/0034939 A1 2/2011 Kveen et al.  
 2011/0071586 A1 3/2011 Jacobson  
 2011/0077708 A1 3/2011 Ostroff  
 2011/0190835 A1 8/2011 Brockway et al.  
 2011/0208260 A1 8/2011 Jacobson  
 2011/0213233 A1 9/2011 Stevenson et al.  
 2011/0218587 A1 9/2011 Jacobson  
 2011/0237967 A1 9/2011 Moore et al.  
 2011/0251660 A1\* 10/2011 Griswold ..... 607/126  
 2011/0251662 A1 10/2011 Griswold et al.

2011/0270339 A1 11/2011 Murray, III et al.  
 2011/0270340 A1 11/2011 Pellegrini et al.  
 2011/0282423 A1 11/2011 Jacobson  
 2012/0078322 A1 3/2012 Dal Molin et al.  
 2012/0089198 A1 4/2012 Ostroff  
 2012/0095521 A1 4/2012 Hintz  
 2012/0095539 A1 4/2012 Khairkahan et al.  
 2012/0101540 A1 4/2012 O'Brien et al.  
 2012/0109236 A1 5/2012 Jacobson et al.  
 2012/0109259 A1 5/2012 Bond et al.  
 2012/0116489 A1 5/2012 Khairkahan et al.  
 2012/0158111 A1 6/2012 Khairkahan et al.  
 2012/0172690 A1 7/2012 Anderson et al.  
 2012/0232565 A1 9/2012 Kveen et al.  
 2013/0268042 A1 10/2013 Hastings et al.

## FOREIGN PATENT DOCUMENTS

EP 1166832 A1 1/2002  
 EP 1264572 A1 12/2002  
 EP 0904009 A1 9/2003  
 EP 1809372 A1 7/2007  
 EP 1812104 A1 8/2007  
 EP 1835962 A1 9/2007  
 EP 2254663 B1 8/2012  
 EP 2001552 B1 9/2012  
 FR 2559391 8/1985  
 JP 61203730 A 9/1986  
 JP 62-254770 A 6/1987  
 JP 02307481 A 12/1990  
 JP 05076501 A2 3/1993  
 JP 05-245215 A 9/1993  
 JP 05245215 9/1993  
 JP 5245215 9/1993  
 JP 5245215 A 9/1993  
 JP 2005245215 A 9/1993  
 JP 6510459 A 11/1994  
 JP 7016299 A 1/1995  
 JP 9508054 A 8/1997  
 JP 10-509901 9/1998  
 JP 2000-502931 A 3/2000  
 JP 2001511406 A 8/2001  
 JP 2002510222 A 4/2002  
 JP 2002-514478 A 5/2002  
 JP 2004-173790 A 6/2004  
 JP 2010509901 3/2010  
 JP 4995090 A 5/2012  
 JP 5153892 B2 2/2013  
 NZ 526115 10/2006  
 NZ 539770 10/2007  
 NZ 539771 10/2007  
 WO WO-9116864 A1 11/1991  
 WO WO-9308771 A1 5/1993  
 WO WO-95010226 A1 4/1995  
 WO WO-9620754 A1 7/1996  
 WO WO-9639932 A1 12/1996  
 WO WO-97025098 A1 7/1997  
 WO WO-9745157 A1 12/1997  
 WO WO-9826840 A1 6/1998  
 WO WO-9829030 A1 7/1998  
 WO WO-9857592 A1 12/1998  
 WO WO-99035533 A1 1/1999  
 WO WO-9906102 A1 2/1999  
 WO WO-1999006102 A1 2/1999  
 WO WO-9958191 A1 11/1999  
 WO WO-99058191 A1 11/1999  
 WO WO-99064104 A1 12/1999  
 WO WO-0030534 A1 6/2000  
 WO WO-01000114 A1 1/2001  
 WO WO-0187137 A2 11/2001  
 WO WO-03041793 A2 5/2003  
 WO WO-03053491 A2 7/2003  
 WO WO-3076010 A1 9/2003  
 WO WO-03082403 A2 10/2003  
 WO WO-03096918 A1 11/2003  
 WO WO-03099102 A2 12/2003  
 WO WO-2004002572 A1 1/2004  
 WO WO-2004012811 A1 2/2004  
 WO WO-2004032788 A2 4/2004

(56)

## References Cited

## FOREIGN PATENT DOCUMENTS

|    |               |    |         |
|----|---------------|----|---------|
| WO | WO-2004078025 | A2 | 9/2004  |
| WO | WO-2005058143 | A2 | 6/2005  |
| WO | WO-2005096954 | A2 | 10/2005 |
| WO | WO-2005101660 | A1 | 10/2005 |
| WO | WO-2005107852 | A1 | 11/2005 |
| WO | WO-2005107863 | A2 | 11/2005 |
| WO | WO-2005117737 | A2 | 12/2005 |
| WO | WO-06045073   | A1 | 4/2006  |
| WO | WO-06045074   | A2 | 4/2006  |
| WO | WO-06045075   | A1 | 4/2006  |
| WO | WO-2006045073 | A1 | 4/2006  |
| WO | WO-2006096685 | A1 | 9/2006  |
| WO | WO-07067231   | A1 | 6/2007  |
| WO | WO-07067253   | A1 | 6/2007  |
| WO | WO-07078770   | A2 | 7/2007  |
| WO | WO-07115044   | A2 | 10/2007 |
| WO | WO-2007112004 | A2 | 10/2007 |
| WO | WO-2007115044 | A3 | 10/2007 |
| WO | WO-2008011626 | A1 | 1/2008  |
| WO | WO-2008034005 | A2 | 3/2008  |
| WO | WO-2008034005 | A3 | 3/2008  |
| WO | WO-2008111998 | A1 | 9/2008  |
| WO | WO-2009099550 | A1 | 8/2009  |
| WO | WO-2009099597 | A1 | 8/2009  |
| WO | WO-2012082755 | A1 | 6/2012  |

## OTHER PUBLICATIONS

"U.S. Appl. No. 10/971,550, Non-Final Office Action dated Nov. 5, 2007", 19 pgs.  
 "U.S. Appl. No. 10/971,550, Notice of Allowance dated Jul. 14, 2008", 4 pgs.  
 "U.S. Appl. No. 10/971,550, Notice of Allowance dated Dec. 22, 2008", 4 pgs.  
 "U.S. Appl. No. 10/971,550, Response filed Feb. 22, 2007 to Restriction Requirement dated Jan. 22, 2007", 1 pg.  
 "U.S. Appl. No. 10/971,550, Response filed Mar. 25, 2008 to Non Final Office Action dated Nov. 5, 2007", 17 pgs.  
 "U.S. Appl. No. 10/971,550, Response filed Sep. 4, 2007 to Non-Final Office Action dated Mar. 19, 2007", 15 pgs.  
 "U.S. Appl. No. 10/971,550, Restriction Requirement dated Jan. 22, 2007", 22 pgs.  
 "U.S. Appl. No. 11/075,375, Restriction Requirement dated Apr. 10, 2007", 6 pgs.  
 "U.S. Appl. No. 11/075,375, Final Office Action dated Jan. 23, 2008", 10 pgs.  
 "U.S. Appl. No. 11/075,375, Non-Final Office Action dated Jun. 8, 2007", 11 pgs.  
 "U.S. Appl. No. 11/075,375, Non-Final Office Action dated Aug. 11, 2008", 15 pgs.  
 "U.S. Appl. No. 11/075,375, Response filed Jan. 12, 2009 to Non-Final Office Action dated Aug. 11, 2008", 18 pgs.  
 "U.S. Appl. No. 11/075,375, Response filed May 7, 2007 to Restriction Requirement dated Apr. 10, 2007", 8 pgs.  
 "U.S. Appl. No. 11/075,375, Response filed May 22, 2008 to Final Office Action dated Jan. 23, 2008", 16 pgs.  
 "U.S. Appl. No. 11/075,375, Response filed Jul. 16, 2009 to Final Office Action dated Apr. 16, 2009", 13 pgs.  
 "U.S. Appl. No. 11/075,375, Response filed Oct. 26, 2007 to Non-Final Office Action dated Jun. 8, 2007", 10 pgs.  
 "U.S. Appl. No. 11/075,376, Final Office Action dated Jan. 7, 2008", 11 pgs.  
 "U.S. Appl. No. 11/075,376, Non-Final Office Action dated Jun. 26, 2007", 9 pgs.  
 "U.S. Appl. No. 11/075,376, Non-Final Office Action dated Aug. 20, 2008", 16 pgs.  
 "U.S. Appl. No. 11/075,376, Restriction Requirement dated Apr. 10, 2007", 6 pgs.  
 "U.S. Appl. No. 11/075,376, Response filed Jan. 21, 2009 to Non-Final Office Action dated Aug. 20, 2009", 22 pgs.

"U.S. Appl. No. 11/075,376, Response filed May 7, 2007 to Restriction Requirement dated Apr. 10, 2007", 10 pgs.  
 "U.S. Appl. No. 11/075,376, Response filed May 7, 2007 to Restriction Requirement dated Apr. 10, 2007", 8 pgs.  
 "U.S. Appl. No. 11/075,376, Response filed Jun. 9, 2008 to Final Office Action dated Jan. 7, 2008", 20 pgs.  
 "U.S. Appl. No. 11/075,376, Response filed Jul. 8, 2009 to Final Office Action dated Apr. 8, 2009", 11 pgs.  
 "U.S. Appl. No. 11/075,376, Response filed Oct. 26, 2007 to Non-Final Office Action dated Jun. 26, 2007", 14 pgs.  
 "U.S. Appl. No. 11/316,120, Final Office Action dated Aug. 20, 2008", 9 pgs.  
 "U.S. Appl. No. 11/316,120, Response filed Apr. 12, 2010 to Final Office Action dated Nov. 12, 2009", 12 pgs.  
 "U.S. Appl. No. 11/316,120, Response filed May 14, 2008 to Non Final Office Action dated Apr. 11, 2008", 12 pgs.  
 "U.S. Appl. No. 11/316,120, Response filed Jul. 17, 2009 to Non Final Office Action dated Apr. 17, 2009", 13 pgs.  
 "U.S. Appl. No. 11/316,120, Response filed Aug. 27, 2010 to Non Final Office Action dated May 27, 2010", 13 pgs.  
 "U.S. Appl. No. 11/316,120, Response filed Dec. 22, 2008 to Final Office Action dated Aug. 20, 2008", 13 pgs.  
 "U.S. Appl. No. 11/316,120, Supplemental Notice of Allowance dated Sep. 1, 2011", 4 pgs.  
 "U.S. Appl. No. 11/490,576, Non Final Office Action dated Jul. 9, 2008", 16 pgs.  
 "U.S. Appl. No. 11/490,576, Pre-Appeal Brief Request filed May 12, 2011", 5 pgs.  
 "U.S. Appl. No. 11/490,576, Response filed Mar. 5, 2010 to Non Final Office Action dated Oct. 5, 2009", 13 pgs.  
 "U.S. Appl. No. 11/490,576, Response filed Apr. 9, 2012 to Non Final Office Action dated Nov. 9, 2011", 11 pgs.  
 "U.S. Appl. No. 11/490,576, Response filed Jun. 17, 2009 to Non Final Office Action dated Feb. 17, 2009", 13 pgs.  
 "U.S. Appl. No. 11/490,576, Response filed Oct. 4, 2010 to Non Final Office Action dated Jul. 12, 2010", 15 pgs.  
 "U.S. Appl. No. 11/490,576, Response filed Nov. 10, 2008 to Non-Final Office Action dated Jul. 9, 2008", 20 pgs.  
 "U.S. Appl. No. 11/490,916, Response filed Apr. 15, 2010 to Final Office Action dated Dec. 17, 2009", 12 pgs.  
 "U.S. Appl. No. 11/490,916, Response filed Sep. 3, 2009 to Non Final Office Action dated May 5, 2009", 13 pgs.  
 "U.S. Appl. No. 11/490,916, Restriction Requirement dated Dec. 11, 2008", 8 pgs.  
 "U.S. Appl. No. 11/511,152, Non-Final Office Action dated Dec. 23, 2008", 14 pgs.  
 "U.S. Appl. No. 11/511,152, Preliminary Amendment filed Oct. 17, 2006", 3 pgs.  
 "U.S. Appl. No. 11/511,152, Response filed Mar. 23, 2009 to Non Final Office Action dated Dec. 23, 2008", 11 pgs.  
 "U.S. Appl. No. 11/511,152, Response filed Jun. 30, 2010 to Non-Final Office Action dated Dec. 30, 2009", 12 pgs.  
 "U.S. Appl. No. 11/511,152, Response filed Nov. 12, 2009 to Final Office Action dated Aug. 10, 2009", 13 pgs.  
 "U.S. Appl. No. 11/549,352, Appeal Brief filed Sep. 9, 2009", 36 pgs.  
 "U.S. Appl. No. 11/549,352, Examiner Interview Summary dated Jun. 25, 2008", 2 pgs.  
 "U.S. Appl. No. 11/549,352, Examiner's Answer dated Nov. 27, 2009 to Appeal Brief filed Sep. 9, 2009", 12 pgs.  
 "U.S. Appl. No. 11/549,352, Final Office Action dated Mar. 9, 2009", 10 pgs.  
 "U.S. Appl. No. 11/549,352, Final Office Action dated Aug. 26, 2008", 13 pgs.  
 "U.S. Appl. No. 11/549,352, Non-Final Office Action dated Feb. 5, 2008", 11 pgs.  
 "U.S. Appl. No. 11/549,352, Notice of Panel Decision from Pre-Appeal Brief Review dated Feb. 2, 2009", 2 pgs.  
 "U.S. Appl. No. 11/549,352, Pre-Appeal Brief for Review filed Dec. 20, 2008", 5 pgs.  
 "U.S. Appl. No. 11/549,352, Reply Brief filed Jan. 27, 2010", 8 pgs.  
 "U.S. Appl. No. 11/549,352, Response filed Jul. 7, 2008 to Non-Final Office Action dated Feb. 5, 2008", 17 pgs.

(56)

## References Cited

## OTHER PUBLICATIONS

- "U.S. Appl. No. 11/549,352, Restriction Requirement dated Aug. 12, 2013", 5 pgs.
- "U.S. Appl. No. 11/683,577, Response filed May 7, 2010 to Final Office Action dated Nov. 9, 2009", 14 pgs.
- "U.S. Appl. No. 11/683,577, Response filed Aug. 5, 2009 to Non Final Office Action dated Mar. 5, 2009", 10 pgs.
- "U.S. Appl. No. 11/683,584, Notice of Allowance dated Aug. 7, 2012", 6 pgs.
- "U.S. Appl. No. 11/683,584, Preliminary Amendment filed Mar. 8, 2007", 1 pg.
- "U.S. Appl. No. 11/683,584, Response filed Jul. 1, 2009 to Non Final Office Action dated Apr. 1, 2009", 7 pgs.
- "U.S. Appl. No. 11/683,584, Response filed Jul. 21, 2010 to Final Office Action dated Jan. 29, 2010", 12 pgs.
- "U.S. Appl. No. 11/745,070, Response filed Jul. 27, 2009 to Non Final Office Action dated Apr. 27, 2009", 11 pgs.
- "U.S. Appl. No. 11/745,105, Notice of Allowance dated Aug. 20, 2012", 5 pgs.
- "U.S. Appl. No. 11/745,105, Response filed Jan. 19, 2010 to Non Final Office Action dated Sep. 18, 2009", 12 pgs.
- "U.S. Appl. No. 11/745,105, Response filed Jun. 22, 2009 to Restriction Requirement dated May 21, 2009", 6 pgs.
- "U.S. Appl. No. 11/745,105, Response filed Jul. 29, 2010 to Final Office Action dated Mar. 30, 2010", 12 pgs.
- "U.S. Appl. No. 11/745,105, Response filed Aug. 6, 2012 to Non Final Office Action dated Feb. 7, 2012", 11 pgs.
- "U.S. Appl. No. 11/745,105, Response filed Sep. 12, 2011 to Non-Final Office Action dated May 11, 2011", 13 pgs.
- "U.S. Appl. No. 12/361,884, Preliminary Amendment filed Jun. 30, 2011", 12 pgs.
- "U.S. Appl. No. 12/361,884, Response filed Apr. 12, 2012 to Non Final Office Action dated Oct. 12, 2011", 21 pgs.
- "U.S. Appl. No. 12/361,884, Supplemental Preliminary Amendment filed Jul. 27, 2011", 12 pgs.
- "U.S. Appl. No. 12/910,106, Response filed Aug. 2, 2011 to Non-Final Office Action dated Apr. 4, 2011", 14 pgs.
- "U.S. Appl. No. 11/549,352, Appeal Decision mailed Jul. 17, 2012", 9 pgs.
- "European Application Serial No. 07759589.0, Response filed Jun. 24, 2010 to Office Action dated Feb. 18, 2010", 6 pgs.
- "International Application Serial No. PCT/US2005/037979, International Search Report dated Mar. 21, 2006", 4 pgs.
- "International Application Serial No. PCT/US2005/037979, Written Opinion dated Mar. 21, 2006", 8 pgs.
- "International Application Serial No. PCT/US2006/040291, Search Report dated Apr. 4, 2007", 5 pgs.
- "International Application Serial No. PCT/US2006/040291, Written Opinion dated Apr. 4, 2007", 9 pgs.
- "International Application Serial No. PCT/US2007/074135, International Search Report dated Nov. 6, 2007", 4 pgs.
- "International Application Serial No. PCT/US2007/074135, Written Opinion dated Nov. 6, 2007", 8 pgs.
- "International Application Serial No. PCT/US2007/078405, International Search Report dated May 20, 2008", p. 220, 7 pgs.
- "International Application Serial No. PCT/US2007/078405, Written Opinion dated May 20, 2008", p. 237, 7 pgs.
- "Japanese Application Serial No. 2008-544324, Response filed Jan. 27, 2012", (w/ English Translation of Amended Claims), 10 pgs.
- "Japanese Application Serial No. 2008-544332, Response filed Mar. 19, 2012 to Office Action dated Nov. 29, 2011", (w/ English Translation of Claims), 9 pgs.
- "Japanese Application Serial No. 2009-503252, Response filed Jun. 20, 2012 to Office Action dated Mar. 21, 2012", (w/ English Claims), 9 pgs.
- "Telemetry Research Transcutaneous Energy Transfer (TET) Technology Summary", Telemetry Research Ltd., www.telemetryresearch.com, (No date listed), 1 pg.
- Busch, M., et al., "On the Heating of Inductively Coupled Resonators (Stents) During MRI Examinations", *Magnetic Resonance in Medicine*, 54, (2005), 775-785.
- Manoharan, G., et al., "Novel passive implantable atrial defibrillator using transcutaneous radiofrequency energy transmission successfully cardioverts atrial fibrillation.", *Circulation*, 108(11), (Sep. 16, 2003), 1382-8.
- Piella, J. P., "Energy management, wireless and system solutions for highly integrated implantable devices", Doctoral Thesis by Jordi Parramon I Piella for the Universitat Autònoma de Barcelona, certified Dec. 2001, (2001), 62 pgs.
- Si, Ping, et al., "A Frequency Control Method for Regulating Wireless Power to Implantable Devices", *IEEE Transactions on Biomedical Circuits and Systems*, 2(1), (Mar. 2008), 22-29.
- Swain, E., "Breakthrough Products Could Put Lesser-Known Firms on the map", *MDDI*, (Apr. 2004), 6 pgs.
- Wagner, Brian K., "Electrodes, Leads, and Biocompatibility", Chapter 6—Design of Cardiac Pacemakers, edited by John G. Webster, (1995), 133-160.
- "U.S. Appl. No. 10/971,550, 312 Amendment filed Mar. 20, 2009", 6 pgs.
- "U.S. Appl. No. 10/971,550, PTO Response to 312 Amendment dated Apr. 6, 2009", 2 pgs.
- "U.S. Appl. No. 11/075,375, Final Office Action dated Apr. 16, 2009", 10 pgs.
- "U.S. Appl. No. 11/075,375, Notice of Allowance dated Sep. 4, 2009", 6 pgs.
- "U.S. Appl. No. 11/075,376, Final Office Action dated Apr. 8, 2009", 17 pgs.
- "U.S. Appl. No. 11/075,376, Notice of Allowance dated Aug. 24, 2009", 6 pgs.
- "U.S. Appl. No. 11/316,120, Non-Final Office Action dated Apr. 17, 2009", 8 pgs.
- "U.S. Appl. No. 11/316,120, Decision on Pre-Appeal Brief Request dated Apr. 19, 2011", 2 pgs.
- "U.S. Appl. No. 11/316,120, Final Office Action dated Oct. 28, 2010", 8 pgs.
- "U.S. Appl. No. 11/316,120, Final Office Action dated Nov. 12, 2009", 8 pgs.
- "U.S. Appl. No. 11/316,120, Non-Final Office Action dated May 27, 2010", 7 pgs.
- "U.S. Appl. No. 11/316,120, Notice of Allowance dated Jul. 20, 2011", 7 pgs.
- "U.S. Appl. No. 11/316,120, Pre-Appeal Brief Request filed Mar. 25, 2011", 5 pgs.
- "U.S. Appl. No. 11/316,120, Response filed Mar. 25, 2011 to Final Office Action dated Oct. 28, 2010", 8 pgs.
- "U.S. Appl. No. 11/394,601, Decision on Pre-Appeal Brief Request dated Oct. 6, 2010", 2 pgs.
- "U.S. Appl. No. 11/394,601, Final Office Action dated Mar. 22, 2010", 7 pgs.
- "U.S. Appl. No. 11/394,601, Non-Final Office Action dated Sep. 2, 2009", 6 pgs.
- "U.S. Appl. No. 11/394,601, Notice of Allowance dated Dec. 28, 2010", 8 pgs.
- "U.S. Appl. No. 11/394,601, Pre-Appeal Brief Request filed Jul. 21, 2010", 5 pgs.
- "U.S. Appl. No. 11/394,601, Response filed May 4, 2009 to Restriction Requirement dated Apr. 2, 2009", 9 pgs.
- "U.S. Appl. No. 11/394,601, Response filed Dec. 2, 2009 to Non Final Office Action dated Sep. 2, 2009", 11 pgs.
- "U.S. Appl. No. 11/394,601, Restriction Requirement dated Apr. 2, 2009", 10 pgs.
- "U.S. Appl. No. 11/490,576, Decision on Pre-Appeal Brief Request dated Aug. 30, 2011", 2 pgs.
- "U.S. Appl. No. 11/490,576, Final Office Action dated Jan. 19, 2011", 12 pgs.
- "U.S. Appl. No. 11/490,576, Non Final Office Action dated Nov. 9, 2011", 8 pgs.
- "U.S. Appl. No. 11/490,576, Non-Final Office Action dated Feb. 17, 2009", 8 pgs.
- "U.S. Appl. No. 11/490,576, Non-Final Office Action dated Jul. 12, 2010", 8 pgs.

(56)

**References Cited**

## OTHER PUBLICATIONS

- "U.S. Appl. No. 11/490,576, Non-Final Office Action dated Oct. 5, 2009", 8 pgs.
- "U.S. Appl. No. 11/490,576, Notice of Allowance dated Jun. 4, 2012", 8 pgs.
- "U.S. Appl. No. 11/490,916, Examiner Interview Summary dated Apr. 12, 2010", 3 pgs.
- "U.S. Appl. No. 11/490,916, Examiner Interview Summary dated Aug. 19, 2009", 2 pgs.
- "U.S. Appl. No. 11/490,916, Final Office Action dated Dec. 17, 2009", 11 pgs.
- "U.S. Appl. No. 11/490,916, Non Final Office Action dated May 5, 2009", 10 pgs.
- "U.S. Appl. No. 11/490,916, Notice of Allowance dated Jul. 9, 2010", 4 pgs.
- "U.S. Appl. No. 11/490,916, Supplemental Notice of Allowability dated Oct. 14, 2010", 2 pgs.
- "U.S. Appl. No. 11/511,152, Final Office Action dated Aug. 10, 2009", 13 pgs.
- "U.S. Appl. No. 11/511,152, Non-Final Office Action dated Dec. 30, 2009", 13 pgs.
- "U.S. Appl. No. 11/511,152, Notice of Allowance dated Jul. 28, 2010", 6 pgs.
- "U.S. Appl. No. 11/683,577, Examiner Interview Summary dated Jul. 7, 2009", 4 pgs.
- "U.S. Appl. No. 11/683,577, Final Office Action dated Nov. 9, 2009", 14 pgs.
- "U.S. Appl. No. 11/683,577, Non-Final Office Action dated Mar. 5, 2009", 13 pgs.
- "U.S. Appl. No. 11/683,577, Notice of Allowance dated Mar. 5, 2013", 11 pgs.
- "U.S. Appl. No. 11/683,584, Non-Final Office Action dated Apr. 1, 2009", 9 pgs.
- "U.S. Appl. No. 11/683,584, Examiner Interview Summary dated Jul. 7, 2009", 4 pgs.
- "U.S. Appl. No. 11/683,584, Final Office Action dated Jan. 29, 2010", 9 pgs.
- "U.S. Appl. No. 11/745,070, Final Office Action dated Dec. 11, 2009", 18 pgs.
- "U.S. Appl. No. 11/745,070, Non Final Office Action dated Apr. 27, 2009", 11 pgs.
- "U.S. Appl. No. 11/745,105, Final Office Action dated Mar. 30, 2010", 9 pgs.
- "U.S. Appl. No. 11/745,105, Non Final Office Action dated Feb. 7, 2012", 12 pgs.
- "U.S. Appl. No. 11/745,105, Non Final Office Action dated May 11, 2011", 13 pgs.
- "U.S. Appl. No. 11/745,105, Non-Final Office Action dated Sep. 18, 2009", 9 pgs.
- "U.S. Appl. No. 11/745,105, Notice of Allowance dated Oct. 31, 2011", 5 pgs.
- "U.S. Appl. No. 11/745,105, Restriction Requirement dated May 21, 2009", 6 pgs.
- "U.S. Appl. No. 11/854,844, Non Final Office Action dated Jan. 11, 2013", 15 pgs.
- "U.S. Appl. No. 11/854,844, Notice of Allowance dated Sep. 27, 2013", 9 pgs.
- "U.S. Appl. No. 11/854,844, Response filed May 13, 2013 to Non Final Office Action dated Jan. 11, 2013", 15 pgs.
- "U.S. Appl. No. 12/361,884, Advisory Action dated Sep. 10, 2012", 3 pgs.
- "U.S. Appl. No. 12/361,884, Examiner Interview Summary dated Oct. 1, 2012", 3 pgs.
- "U.S. Appl. No. 12/361,884, Final Office Action dated Jul. 3, 2012", 17 pgs.
- "U.S. Appl. No. 12/361,884, Non Final Office Action dated Oct. 12, 2011", 15 pgs.
- "U.S. Appl. No. 12/361,884, Notice of Allowance dated Jan. 17, 2014", 7 pgs.
- "U.S. Appl. No. 12/361,884, Notice of Allowance dated Sep. 25, 2013", 10 pgs.
- "U.S. Appl. No. 12/361,884, Response filed Aug. 28, 2012 to Final Office Action dated Jul. 3, 2012", 18 pgs.
- "U.S. Appl. No. 12/361,884, Response filed Oct. 3, 2012 to Final Office Action dated Jul. 3, 2012", 18 pgs.
- "U.S. Appl. No. 12/365,428, Non Final Office Action dated Aug. 31, 2011", 9 pgs.
- "U.S. Appl. No. 12/365,428, Notice of Allowance dated Feb. 22, 2012", 7 pgs.
- "U.S. Appl. No. 12/365,428, Response filed Jan. 30, 2012 to Non Final Office Action dated Aug. 31, 2011", 15 pgs.
- "U.S. Appl. No. 12/910,106, Non Final Office Action dated Apr. 4, 2011", 9 pgs.
- "U.S. Appl. No. 12/910,106, Notice of Allowance dated Jan. 26, 2012", 6 pgs.
- "U.S. Appl. No. 12/910,106, Notice of Allowance dated Oct. 27, 2011", 5 pgs.
- "U.S. Appl. No. 13/476,599, Examiner Interview Summary dated Dec. 31, 2012", 3 pgs.
- "U.S. Appl. No. 13/476,599, Final Office Action dated Aug. 21, 2013", 8 pgs.
- "U.S. Appl. No. 13/476,599, Non Final Office Action dated Aug. 30, 2012", 6 pgs.
- "U.S. Appl. No. 13/476,599, Response filed Dec. 19, 2012 to Non Final Office Action dated Aug. 30, 2012", 11 pgs.
- "U.S. Appl. No. 13/717,027 Preliminary Amendment Filed Jun. 25, 2013", 6 pgs.
- "U.S. Appl. No. 13/929,286, Non Final Office Action dated Dec. 11, 2013", 15 pgs.
- "U.S. Appl. No. 13/929,286, Preliminary Amendment filed", 7 pgs.
- "European Application Serial No. 05815206.7, Communication dated Dec. 18, 2009", 4 pgs.
- "European Application Serial No. 05815206.7, Office Action dated May 16, 2012", 5 pgs.
- "European Application Serial No. 05815206.7, Office Action dated Sep. 12, 2012", 27 pgs.
- "European Application Serial No. 05815206.7, Response filed Apr. 19, 2010 to Communication dated Dec. 18, 2009", 27 pgs.
- "European Application Serial No. 05815215.8, Communication dated Dec. 18, 2009", 2 pgs.
- "European Application Serial No. 05815215.8, Response filed Mar. 19, 2010 to Communication dated Dec. 18, 2009", 12 pgs.
- "European Application Serial No. 05817448.3, Communication dated Dec. 18, 2009", 2 pgs.
- "European Application Serial No. 05817448.3, Office Action dated May 16, 2012", 5 pgs.
- "European Application Serial No. 05817448.3, Response filed Mar. 19, 2010 to Communication dated Dec. 18, 2009", 9 pgs.
- "European Application Serial No. 05817448.3, Response filed Sep. 14, 2012 to Office Action dated May 16, 2012", 14 pgs.
- "European Application Serial No. 06790023.3, Office Action dated Mar. 4, 2009", 6 pgs.
- "European Application Serial No. 06790023.3, Response filed Sep. 14, 2009 to Office Action dated Mar. 4, 2009", 11 pgs.
- "European Application Serial No. 06825988.6, Office Action dated Mar. 4, 2009", 7 pgs.
- "European Application Serial No. 06825988.6, Response filed Sep. 14, 2009 to Office Action dated Mar. 4, 2009", 12 pgs.
- "European Application Serial No. 06847612.6, Office Action dated May 26, 2009", 3 pgs.
- "European Application Serial No. 06847612.6, Office Action dated Dec. 7, 2010", 4 pgs.
- "European Application Serial No. 06847612.6, Response filed Apr. 12, 2011 to Office Action dated Dec. 7, 2010", 5 pgs.
- "European Application Serial No. 06847612.6, Response filed Oct. 26, 2009 to Office Action dated May 26, 2009", 12 pgs.
- "European Application Serial No. 06847612.6, Summons to Attend Oral Proceedings dated Jun. 20, 2012", 3 pgs.
- "European Application Serial No. 07759589.0, Office Action dated Feb. 18, 2010", 3 pgs.
- "European Application Serial No. 07759589.0, Response filed Jun. 5, 2009 to Office Action dated Jan. 29, 2009", 6 pgs.

(56)

**References Cited**

## OTHER PUBLICATIONS

“European Application Serial No. 07759589.0, Summons to Attend Oral Proceedings dated May 17, 2011”, 3 pgs.

“European Application Serial No. 07759589.0, Written Submission filed Dec. 5, 2011 to Summons to Attend Oral Proceedings dated May 17, 2011”, 16 pgs.

“European Application Serial No. 09709347.0, Office Action dated Oct. 4, 2010”, 1 pg.

“European Application Serial No. 09709347.0, Response filed Oct. 28, 2010 to Office Action dated Oct. 4, 2010”, 7 pgs.

“International Application Serial No. PCT/US2005/037978, Written Opinion dated Jun. 13, 2006”, 12 pgs.

“International Application Serial No. PCT/US2007/078405, International Preliminary Report on Patentability dated Mar. 26, 2009”, 9 pgs.

“International application serial No. PCT/US2009/000587 Written Opinion dated Apr. 24, 2009”, 8 pgs.

“International Application Serial No. PCT/US2009/000587, International Preliminary Report on Patentability dated Aug. 19, 2010”, 10 pgs.

“International Application Serial No. PCT/US2009/000587, International Search Report dated Apr. 24, 2009”, 7 pgs.

“International Application Serial No. PCT/US2009/000693, International Preliminary Report on Patentability dated Aug. 19, 2010”, 9 pgs.

“International Application Serial No. PCT/US2009/000693, International Search Report dated May 8, 2009”, 5 pgs.

“International Application Serial No. PCT/US2009/000693, Written Opinion dated May 8, 2009”, 8 pgs.

“Japanese Application Serial No. 2007-538087, Office Action dated Apr. 11, 2011”, (w/ English Translation), 5 pgs.

“Japanese Application Serial No. 2007-538087, Office Action dated Apr. 17, 2012”, w/ English Translation, 8 pgs.

“Japanese Application Serial No. 2007-538087, Office Action dated Oct. 5, 2011”, (w/ English Translation), 14 pgs.

“Japanese Application Serial No. 2007-538087, Response filed Mar. 23, 2012 to Office Action dated Oct. 5, 2011”, (w/ English Translation of Claims), 9 pgs.

“Japanese Application Serial No. 2007-538087, Response filed Jun. 27, 2011 to Office Action dated Apr. 11, 2011”, (w/ English Translation of Amended Claims), 12 pgs.

“Japanese Application Serial No. 2007-538087, Response filed Jul. 13, 2012 to Office Action dated Apr. 17, 2012”, (w/ English Translation of Amended Claims), 13 pgs.

“Japanese Application Serial No. 2007-538088, Notice of Final Rejection dated Dec. 6, 2011”, (w/ English Translation), 9 pgs.

“Japanese Application Serial No. 2007-538088, Office Action dated Jun. 13, 2011”, (w/ English Translation), 5 pgs.

“Japanese Application Serial No. 2007-538088, Response filed Mar. 27, 2012 to Final Office Action dated Dec. 6, 2011”, (w/ English Translation of Claims), 11 pgs.

“Japanese Application Serial No. 2007-538088, Response filed Aug. 25, 2011 to Office Action dated Jun. 13, 2011”, (w/ English Translation of Amended Claims), 9 pgs.

“Japanese Application Serial No. 2007-538089, Office Action dated Mar. 3, 2011”, (w/ English Translation), 6 pgs.

“Japanese Application Serial No. 2007-538089, Response filed May 25, 2011 to Office Action dated Mar. 3, 2011”, (w/ English Translation of Amended Claims), 8 pgs.

“Japanese Application Serial No. 2008-544324, Office Action dated May 22, 2012”, (w/ English Translation), 5 pgs.

“Japanese Application Serial No. 2008-544324, Office Action dated Nov. 22, 2011”, (w/ English Translation), 5 pgs.

“Japanese Application Serial No. 2008-544332, Office Action dated Nov. 29, 2011”, (w/ English Translation), 5 pgs.

“Japanese Application Serial No. 2009-503252, Office Action dated Mar. 21, 2012”, (w/ English Translation), 9 pgs.

“Japanese Application Serial No. 2009-503252, Response filed Oct. 26, 2012 to Office Action dated Oct. 10, 2012”, With English Claims, 6 pgs.

“Japanese Application Serial No. 2010-545866, Office Action dated Jun. 5, 2012”, (w/ English Translation), 5 pgs.

“Japanese Application Serial No. 2010-545866, Response filed Sep. 5, 2012 to Office Action dated Jun. 5, 2012”, (w/ English Translation of Amended Claims), 12 pgs.

\* cited by examiner



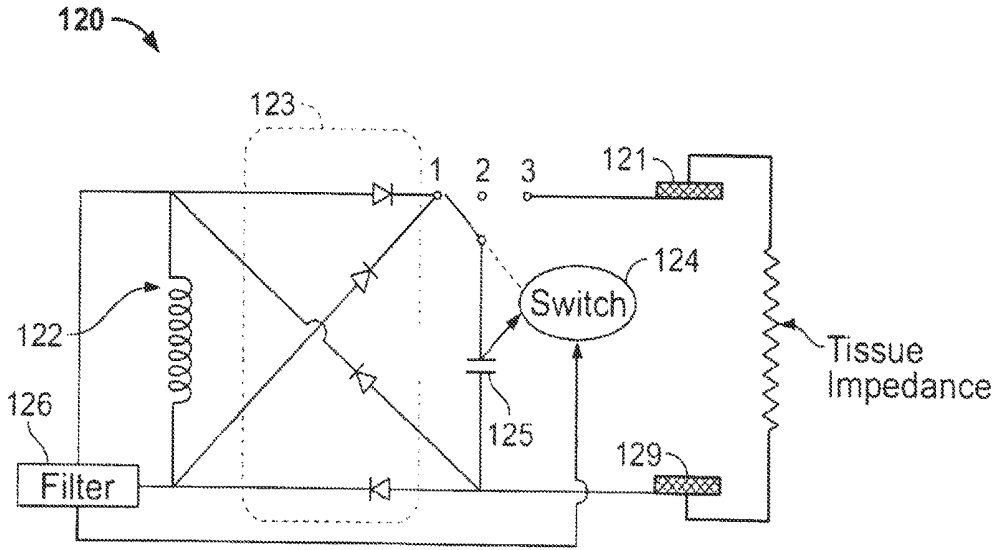

FIG. 3

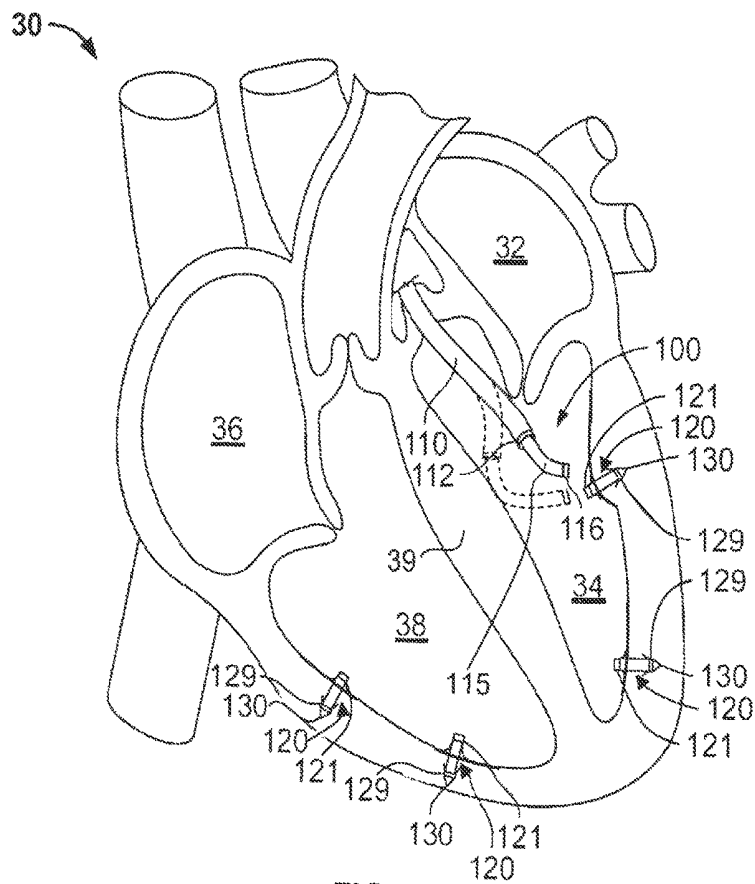

FIG. 4

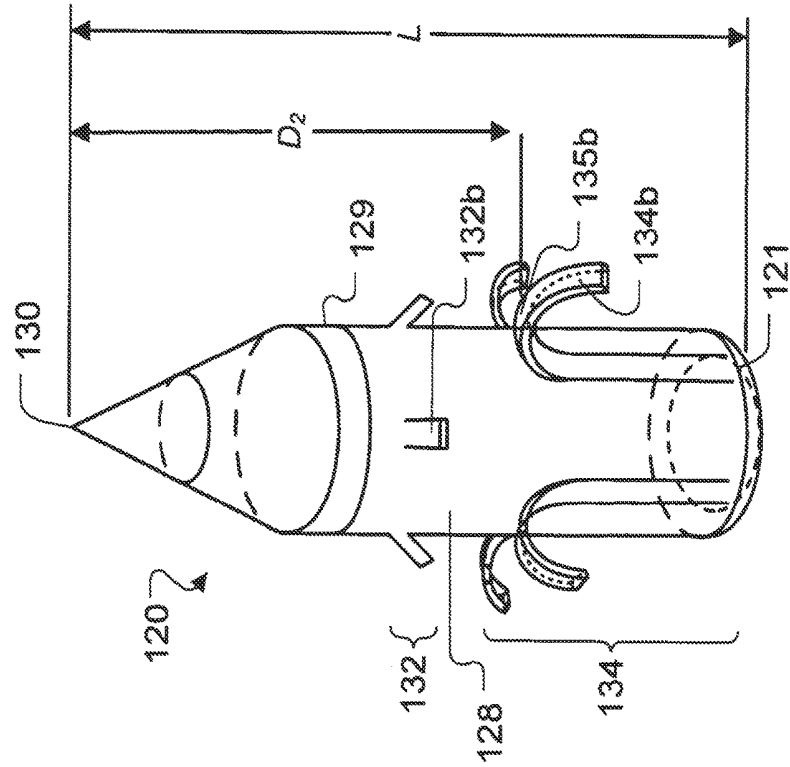

FIG. 5

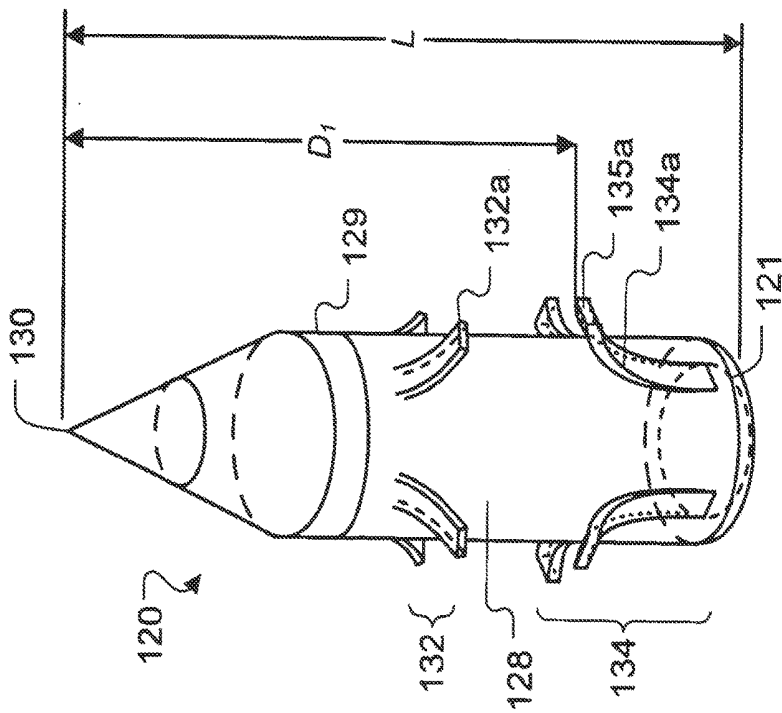

FIG. 6

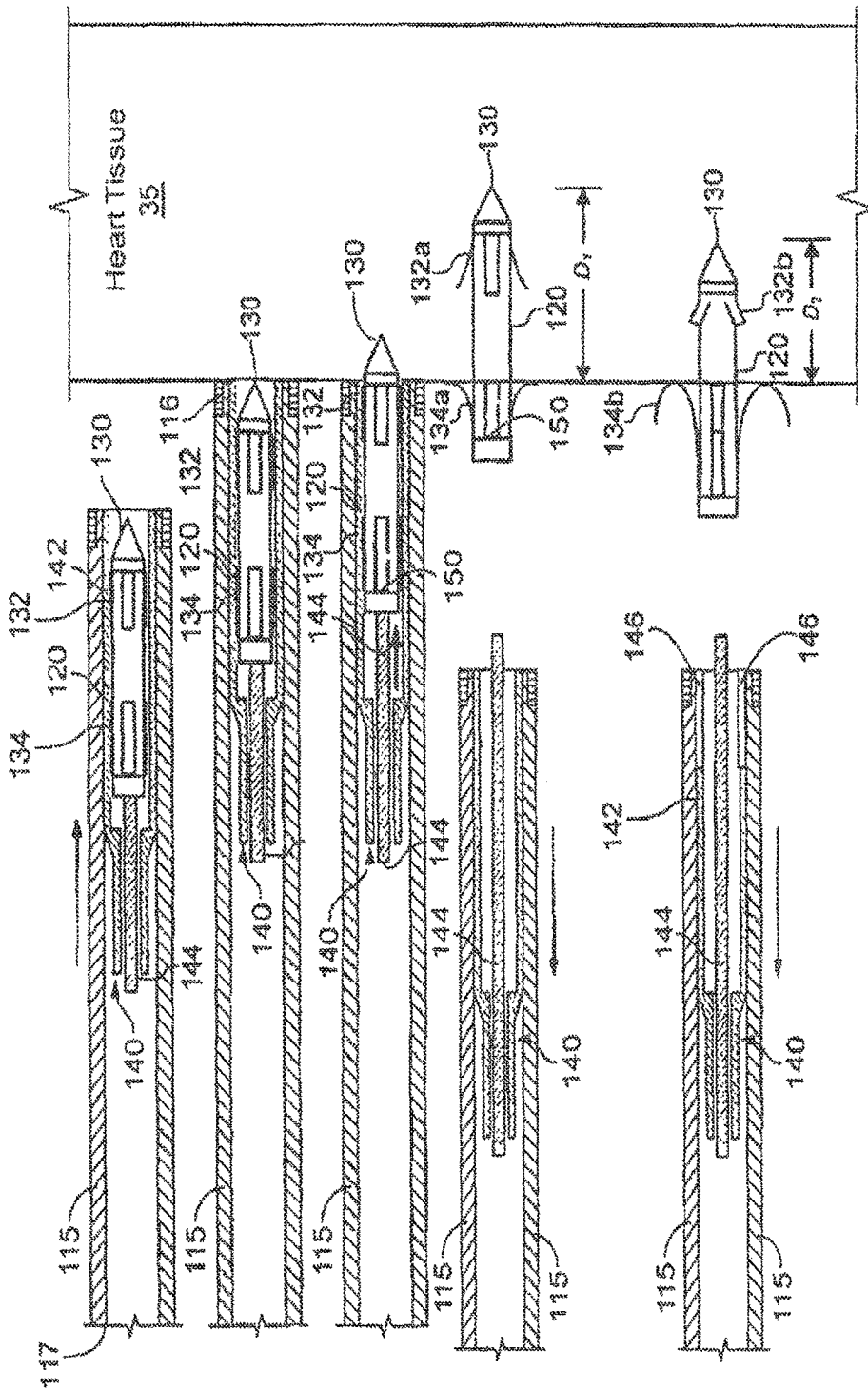

FIG. 7A

FIG. 7B

FIG. 7C

FIG. 7D

FIG. 8

**CARDIAC STIMULATION SYSTEM****CROSS REFERENCE TO RELATED APPLICATION**

This application is a continuation of U.S. application Ser. No. 11/549,352, filed Oct. 13, 2006, and entitled "CARDIAC STIMULATION SYSTEM," now abandoned, which claims priority to U.S. Provisional Application Ser. No. 60/748,964, filed on Dec. 9, 2005, and entitled "CARDIAC STIMULATION SYSTEM," the contents of each of which are incorporated herein by reference.

**TECHNICAL FIELD**

This document relates to systems that electrically stimulate cardiac or other tissue.

**BACKGROUND**

Pacing instruments can be used to treat patients suffering from a heart condition, such as a reduced ability to deliver sufficient amounts of blood from the heart. For example, some heart conditions may cause or be caused by conduction defects in the heart. These conduction defects may lead to irregular or ineffective heart contractions. Some pacing instruments (e.g., a pacemaker) may be implanted in a patient's body so that pacing electrodes in contact with the heart tissue provide electrical stimulation to regulate electrical conduction in the heart tissue. Such regulated electrical stimulation may cause the heart to contract and hence pump blood.

Conventionally, pacemakers include a pulse generator that is implanted, typically in a patient's pectoral region just under the skin. One or more wired leads extend from the pulse generator so as to contact various portions of the heart. An electrode at a distal end of a lead may provide the electrical contact to the heart tissue for delivery of the electrical pulses generated by the pulse generator and delivered to the electrode through the lead.

The use of wired leads may limit the number of sites of heart tissue at which electrical energy may be delivered. For example, most commercially available pacing leads are not indicated for use in the left side of the heart. One reason is that the high pumping pressure on the left side of the heart may cause a thrombus or clot that forms on a bulky wired lead to eject into distal arteries, thereby causing stroke or other embolic injury. Thus, in order to pace the left side of the heart with a wired lead, most wired leads are directed through the cardiac venous system to a site (external to the left heart chambers) in a cardiac vein over the left side of the heart. While a single lead may occlude a cardiac vein over the left heart locally, this is overcome by the fact that other cardiac veins may compensate for the occlusion and deliver more blood to the heart. Nevertheless, multiple wired leads positioned in cardiac veins can cause significant occlusion, thereby limiting the number of heart tissue sites at which electrical energy may be delivered to the left side of the heart.

Some pacing systems may use wireless electrodes that are attached to the epicardial surface of the heart (external, to the heart chambers) to stimulate heart tissue. In these systems, the wireless electrodes are screwed into the outside surface of the heart wall, which can reduce the effectiveness of the electrical stimulation in some circumstances.

**SUMMARY**

Some embodiments of pacing systems employ wireless electrode assemblies to provide pacing therapy. The wireless

electrode assemblies may receive energy via an inductive coupling so as to provide electrical stimulation to the surrounding heart tissue. In certain embodiments, a wireless electrode assembly may be directed through a guide catheter in a heart chamber to deliver at least a portion of the wireless electrode assembly through the endocardium. For example, the electrode assembly may include first and second fixation devices to secure the electrode assembly to the heart chamber wall. In such circumstances, the first fixation device may oppose rearward migration of the electrode assembly out of the heart chamber wall, and the second fixation device may oppose forward migration into the heart chamber wall. Accordingly, the wireless electrode assembly can be readily secured to the heart chamber wall and incorporated into the surrounding heart tissue over a period of time.

In some embodiments, a wireless electrode assembly may include a body portion that at least partially contains a circuit to electrically stimulate an electrode. The wireless electrode assembly may also include first and second biased tines to shift from a loaded condition to an outwardly extended condition to secure the body portion to a heart chamber wall. The first and second biased tines may be generally opposed to one another.

Particular embodiments may include an electrode delivery system for delivering a wireless electrode assembly into a heart chamber. The system may include a wireless electrode assembly including a body portion and first and second biased tines to shift from a loaded condition to an outwardly extended condition to secure the body portion to a heart chamber wall. The first and second biased tines may oppose one another. The system may also include a delivery catheter to direct the wireless electrode assembly through a heart chamber and toward a heart chamber wall. The delivery catheter may include an opening in a distal end such that when the wireless electrode assembly is separated from the opening in the distal end of the catheter, the first and second biased tines shift from the loaded condition to the outwardly extended condition.

Some embodiments may include a method of inserting a wireless electrode assembly into a heart chamber wall. The method may include inserting a first biased tine of a wireless electrode assembly through a portion of endocardium and into a heart chamber wall. The first biased tine may shift from a loaded condition to an outwardly extended condition to secure the body portion to a heart chamber wall. The method may also include causing a second biased tine of the wireless electrode assembly to shift from the loaded condition to the outwardly extended condition to secure the body portion to a heart chamber wall. The first and second biased tines may be generally opposed to one another when in their respective outwardly extended conditions.

These and other embodiments described herein may provide one or more of the following advantages. First, the wireless electrode assemblies may eliminate or otherwise limit the need for wired pacing leads, thereby reducing the risk of stroke or other embolic injury from a thrombus or clot and reducing the risk of occluding cardiac veins (external to the heart chambers). Second, the wireless electrode assemblies may be secured to the inner wall of one more heart chambers, which may provide more efficient transfer of electrical stimulation. Third, the wireless electrode assemblies may be secured to a heart chamber wall in a manner that opposes both forward migration and rearward migration of the electrode assembly. In such circumstances, the secure attachment of the wireless electrode assembly with the heart wall may increase the likelihood of incorporating the elec-

trode assembly into surrounding tissue, thereby further reducing the likelihood of forming a thrombus or clot in the heart chamber.

The details of one or more embodiments of the invention are set forth in the accompanying drawings and the description below. Other features, objects, and advantages of the invention will be apparent from the description and drawings, and from the claims.

#### DESCRIPTION OF DRAWINGS

FIG. 1 is a perspective view of a stimulation system and at least a portion of an electrode delivery system, in accordance with some embodiments of the invention.

FIG. 2 is a diagram of at least a portion of a device of the stimulation system of FIG. 1.

FIG. 3 is a diagram of at least a portion of a wireless electrode assembly of the stimulation system of FIG. 1.

FIG. 4 is a section view of a heart and at least a portion of the electrode delivery system of FIG. 1.

FIG. 5 is a perspective view of a wireless electrode assembly, in accordance with some embodiments of the invention.

FIG. 6 is a perspective view of a wireless electrode assembly, in accordance with some embodiments of the invention.

FIGS. 7A-D are partial cross-sectional views of the delivery of the wireless electrode assembly of FIG. 5.

FIG. 8 is a partial cross-sectional view of the delivery of the wireless electrode assembly of FIG. 6.

Like reference symbols in the various drawings indicate like elements.

#### DETAILED DESCRIPTION OF ILLUSTRATIVE EMBODIMENTS

Referring to FIG. 1, an electrical stimulation system 10 may include one or more wireless electrode assemblies 120. The wireless electrode assemblies 120 are implanted within chambers of the heart 30. In this example, there are two implanted in the left ventricle 34 and two implanted in the right ventricle 38, but the wireless electrode assemblies may be implanted in the left atrium 32, the right atrium 36, or both. As described below in connection with FIGS. 4-8, the wireless electrode assemblies 120 may be delivered to one or more chambers of the heart 30 using an electrode delivery system 100. The electrode delivery system may include a guide catheter 110 that is directed through one or more veins or arteries to the targeted chamber of the heart 30 (e.g., the left ventricle 34 is the targeted chamber in the embodiment shown in FIG. 1). After the guide catheter 110 is deployed into the targeted heart chamber the wireless electrode assemblies 120 may be consecutively delivered through the guide catheter 110 using at least one delivery catheter 115, which may include a steering mechanism (e.g., steering wires, a shape memory device, or the like) to deliver the wireless electrode assembly 120 to the targeted site on the heart chamber wall.

The distal end of each wireless electrode assembly 120 may include one or more fixation devices, such as tines. As described in more detail below in connection with FIGS. 5 and 6, the tines 132 and 134 can secure the wireless electrode assembly 120 to the heart chamber wall. In some embodiments, each of the wireless electrode assemblies 120 may include a circuit comprising an internal coil and an electrical charge storage device (not shown in FIG. 1). As described in more detail below in connection with FIG. 3,

the internal coil can be inductively coupled with an external power source coil so as to charge the electrical charge storage device (e.g., a battery, capacitor or the like) contained within the wireless electrode assembly 120. Also in some embodiments, each of the wireless electrode assemblies 120 has a triggering mechanism in the circuit to deliver stored electrical charge to adjacent heart tissue (some examples are described in more detail below in connection with FIG. 3). In alternative embodiments, one or more of the wireless electrode assemblies 120 may have no energy storage device. In such circumstances, each wireless electrode assembly may be comprised, for example, of a ferrite core having caps at each end with ring electrodes encircling the caps. A number of turns of fine insulated wire may be wrapped around the central portion of the core so as to receive energy from a magnetic field produced by a shaped driving signal and designed to activate the electrodes.

Referring still to FIG. 1, the system 10 may also include a pacing controller 40 and a transmitter 50 that drives an antenna 60 for communication with the wireless electrode assemblies 120. The pacing controller 40 includes circuitry to sense and analyze the heart's electrical activity, and to determine if and when a pacing electrical pulse needs to be delivered and by which of the wireless electrode assemblies 120. The sensing capability may be made possible by having sense electrodes included within the physical assembly of the pacing controller 40. Alternatively, a conventional single or dual lead pacemaker may sense the local cardiac electrocardiogram (ECG) and transmit this information to antenna 60 for use by controller 40 in determination of the timing of wireless electrode assembly firing. In either case, the wireless electrode assembly 120 need not be provided with sensing capability, and also the wireless electrode assemblies 120 need not be equipped with the capability of communicating to the pacing controller 40 (for example, to communicate information about sensed electrical events). In alternative embodiments, the wireless electrode assemblies may communicate sensed information to each other and/or to the controller 40.

The transmitter 50—which is in communication with, and is controlled by, the pacing controller 40—may drive an RF signal onto the antenna 60. In one embodiment, the transmitter 50 provides both (1) a charging signal to charge the electrical charge storage devices contained within the wireless electrode assemblies 120 by inductive coupling, and (2) an information signal, such as a pacing trigger signal, that is communicated to a selected one or more of the wireless electrode assemblies 120, commanding that wireless electrode assembly 120 deliver its stored charge to the adjacent heart tissue.

One parameter of the wireless electrode assembly 120 that may affect the system design is the maximum energy required to pace the ventricle 34, 38 or other chamber of the heart 30. This energy requirement can include a typical value needed to pace ventricular myocardium, but also can include a margin to account for degradation of contact between the electrodes and tissue over time. In certain embodiments, each wireless electrode assembly 120 may require the maximum pacing threshold energy. This threshold energy is supplied to the wireless electrode assemblies between heartbeats by an external radio frequency generator (which may also be implanted), or other suitable energy source that may be implanted within the body. Parameter values for some embodiments may be:

Threshold pacing voltage=2.5 Volts  
 Typical lead impedance=600 Ohms  
 Typical pulse duration=0.4 mSec

Derived threshold energy=4 micro-Joules

Because RF fields at frequencies higher than about 200 kHz may be attenuated by the body's electrical conductivity and because electric fields of any frequency may be attenuated within the body, energy transmission through the body may be accomplished in some embodiments via a magnetic field at about 20-200 kHz (or by a magnetic field pulse that contains major frequency components in this range) and preferably by transmission of magnetic fields in the range of 100-200 kHz when transmission is through relatively conductive blood and heart muscle.

Still referring to FIG. 1, the pacing controller 40 and the transmitter 50 may be housed in a single enclosure that is implantable within a patient. In such a configuration, the single enclosure device may have a single energy source (battery) that may be either rechargeable or non-rechargeable. In another configuration, the pacing controller 40 and the transmitter 50 may be physically separate components. As an example of such a configuration, the pacing controller 50 may be implantable, for example in the conventional pacemaker configuration, whereas the transmitter 50 (along with the antenna 60) may be adapted to be worn externally, such as in a harness that is worn by the patient. In the latter example, the pacing controller 40 would have its own energy source (battery), and that energy would not be rechargeable given the relatively small energy requirements of the pacing controller 40 as compared to the energy requirements of the transmitter 50 to be able to electrically charge the wireless electrode assemblies 120. In this case, the pacing controller 40 would sense the local cardiac ECG signal through a conventional pacing lead, and transmit the sensed information to the external controller. Again, transmission of information, as opposed to pacing energy, has a relatively low power requirement, so a conventional pacemaker enclosure and battery would suffice.

The external programmer 70 is used to communicate with the pacing controller 40, including after the pacing controller 40 has been implanted. The external programmer 70 may be used to program such parameters as the timing of stimulation pulses in relation to certain sensed electrical activity of the heart, the energy level of stimulation pulses, the duration of stimulation pulse (that is, pulse width) etc. The programmer 70 includes an antenna 75 to communicate with the pacing controller 40, using, for example, RF signals. The implantable pacing controller 40 is accordingly equipped to communicate with the external programmer 70, using, for example, RF signals. The antenna 60 may be used to provide such communications, or alternatively, the pacing controller 40 may have an additional antenna (not shown in FIG. 1) for external communications with the programmer 70, and in an embodiment where the transmitter 50 and antenna 60 are housed separately from the controller 40, for communications with the transmitter 50.

Still referring to FIG. 1, at least a portion of the system 10 is shown as having been implanted in a patient, and in addition, the programmer 70 is also shown that is external to the patient. The controller 40 and transmitter 50 may be housed in a device that is shaped generally elongate and slightly curved so that it may be anchored between two ribs of the patient, or possibly around two or more ribs. In one example, the housing for the controller 40 and transmitter 50 is about 2 to 20 cm long and about 1 to 10 centimeters cm in diameter, may be about 5 to 10 cm long and about 3 to 6 cm in diameter. Such a shape of the housing for the controller 40 and transmitter 50, which allows the device to be anchored on the ribs, may provide an enclosure that is larger and heavier than conventional pacemakers, and may

provide a larger battery having more stored energy. In addition, the controller 40 may comprise a defibrillator that discharges energy to the heart 30 through electrodes on the body of controller 40 when fibrillation is sensed. Other sizes and configurations may also be employed as is practical.

In some embodiments, the antenna 60 may be loop antenna comprised of a long wire that is electrically connected across an electronic circuit contained within the controller/transmitter housing, which circuit delivers pulses of RF current to the antenna 60, generating a magnetic field in the space around the antenna 60 to charge the wireless electrode assemblies 120, as well as RF control magnetic field signals to command the wireless electrode assemblies 120 to discharge. In such embodiments, the antenna 60 may comprise a flexible conductive material so that it may be manipulated by a physician during implantation into a configuration that achieves improved inductive coupling between the antenna 60 and the coils within the implanted wireless electrode assemblies 120. In one example, the loop antenna 60 may be about 2 to 22 cm long, and about 1 to 11 cm wide, and may be about 5 to 11 cm long, and about 3 to 7 cm wide. Placement of the antenna 60 over the ribs may provide a relatively large antenna to be constructed that has improved efficiency in coupling RF energy to the pacing wireless electrode assemblies 120.

As shown in FIG. 1, some embodiments of the system 10 may also include a pulse generator device 90 (or pacemaker device) and associated wired leads 95 which extend from the pulse generator device 90 and into one or more chambers of the heart 30 (e.g., into the right atrium 36). For example, the system 10 may include wired leads 95 from the pulse generator device 90 that extend into the right atrium 36 and the right ventricle 38 while wireless electrode assemblies are disposed in the left atrium 32 and the left ventricle 34. The pulse generator device 90 may be used to sense the internal ECG, and may also communicate with the controller 40 and/or transmitter 50 as previously described.

As previously described, in some embodiments, each of the wireless electrode assemblies 120 includes a rechargeable battery or other charge storage device. This battery may provide power for delivering pacing energy to the tissue, and for operating communications, logic, and memory circuitry contained within the assembly. In some alternative embodiments, a transmitter and an antenna may be external to the patient (as opposed to the implantable transmitter 50 and antenna 60 depicted in FIG. 1), and may serve to recharge the batteries within the electrode assemblies. The recharge transmitter and antenna may be incorporated into furniture, incorporated into the patient's bed, or worn by the patient (e.g., in a vest-type garment). Daily recharging for predetermined to periods (e.g., about 30 minutes) may be required in some cases, in these circumstances, the wireless electrode assemblies 120 may be autonomous pacemaker-like devices, which can sense the local electrogram and only pace when the local tissue is not refractory. Such electrodes may communicate with the programming unit 70 to receive pacing instructions and transmit data stored in local memory. In these embodiments, each wireless electrode assembly 120 may also communicate with other implanted wireless electrode assemblies 120. For example, one electrode assembly 120 in the right atrium may be designated as the "master," and all other implanted electrodes are "slaves," that pace with pre-programmed delays relative to the "master." As such, a master electrode in the right atrium may only sense the heart's sinus rhythm, and trigger pacing of the slaves with programmed delays.

Referring to FIG. 2, an embodiment of a device 80 including the controller 40, transmitter 50, associated antenna 60 is shown in block diagram form. Included within the device 80 is: a battery 82, which may be recharged by receiving RF energy from a source outside the body via antenna 60; ECG sensing electrodes 84 and associated sensing circuitry 86; circuitry 87 for transmitting firing commands to the implanted wireless electrode assemblies, transmitting status information to the external programmer, receiving control instructions from the external programmer and receiving power to recharge the battery; and a controller or computer 88 that is programmed to control the overall functioning of the pacing control implant. In alternative embodiments, antenna 60 may receive signals from the individual wireless electrode assemblies 120 containing information regarding the local ECG at the site of each wireless electrode assembly, and/or the antenna 60 may receive signals from a more conventional implanted pacemaker regarding the ECG signal at the sites of one or more conventional leads implanted on the right side of the heart.

Referring to FIG. 3, some embodiments of a wireless electrode assembly 120 may include a receiver coil 122 that is capable of being inductively coupled to a magnetic field source generating a time-varying magnetic field at the location of coil 122, such as would be generated by the transmitter 50 and the antenna 60 depicted in FIG. 1. The RF current in the external antenna may be a pulsed alternating current (AC) or a pulsed DC current, and thus the current induced through the receiver coil 122 would likewise be an AC or pulsed DC current. The current induced in coil 122 may be proportional to the time rate of change of the magnetic field generated at the site of coil 122 by the external RF current source. In some embodiments, a four-diode bridge rectifier 123 may be connected across the receiver coil 122 to rectify the AC or pulsed DC current that is induced in the receiver coil 122. A three-position switch device 124 may be connected so that when the switch device 124 is in a first position, the rectifier 123 produces a rectified output that is imposed across a capacitor 125. As such, when the switch device 124 is in the position 1 (as is the case in FIG. 4), the capacitor 125 stores the induced electrical energy.

The switch device 124, in this example, is a voltage controlled device and is connected to sense a voltage across the capacitor 125 to determine when the capacitor 125 has been sufficiently charged to a specified pacing threshold voltage level. When the capacitor 125 is sensed to have reached the specified pacing threshold level, the voltage-controlled switch device 124 moves to a position 2, which disconnects the capacitor 125 from the coil 122. With the switch device 124 in the position 2, the capacitor 125 is electrically isolated and remains charged, and thus is ready to be discharged. The voltage controlled switch device 124 may comprise a solid state switch, such as a field effect transistor, with its gate connected to the output of a voltage comparator that compares the voltage on capacitor 125 to a reference voltage. The reference voltage may be set at the factory, or adjusted remotely (e.g., after being implanted) via signals sent from the physician programmer unit 70 (FIG. 1), received by coil 122 and processed by circuitry not shown in FIG. 3. Any electronic circuitry contained within the wireless electrode assembly 120, including the voltage controlled switch, can be constructed with components that consume very little power, for example CMOS. Power for such circuitry is either taken from a micro-battery contained within the wireless electrode assembly, or supplied by draining a small amount of charge from capacitor 125.

Still referring to FIG. 3, a narrow band pass filter device 126 may also be connected across the receiver coil 122, as well as being connected to the three-position switch device 124. The band pass filter device 126 passes only a single frequency or communication signal that is induced in the coil 122. The single frequency of the communication signal that is passed by the filter device 126 may be unique for the particular wireless electrode assembly 120 as compared to other implanted wireless electrode assemblies. When the receiver coil 122 receives a short magnetic field burst at this particular frequency, the filter device 126 passes the voltage to the switch device 124, which in turn moves to a position 3.

With the switch device 124 in the position 3, the capacitor 125 may be connected in series through two bipolar electrodes 121 and 129, to the tissue to be stimulated. As such, at least some of the charge that is stored on the capacitor 125 is discharged through the tissue. When this happens the tissue becomes electrically depolarized. In one example embodiment described in more detail below, the bipolar electrodes 121 and 129 across which stimulation pulses are provided are physically located at opposite ends (e.g., a proximal end and a distal end) of the wireless electrode assembly 120. After a predetermined, or programmed, period of time, the switch returns to position 1 on the capacitor 125 may be charged back up to the selected threshold level.

It should be noted that, for sake of clarity, the schematic diagram of FIG. 3 shows only the electrical components for energy storage and switching for particular embodiments of the wireless electrode assembly 120. Not necessarily shown are electronics to condition the pacing pulse delivered to the tissues, which circuitry should be understood from the description herein. Some aspects of the pulse, for example pulse width and amplitude, may be remotely programmable via encoded signals received through the filter device 126 of the wireless electrode assembly 120. In this regard, filter 126 may be a simple band pass filter with a frequency unique to a particular wireless electrode assembly, and the incoming signal may be modulated with programming information. Alternatively, filter 126 may consist of any type of demodulator or decoder that receives analog or digital information induced by the external source in coil 122. The received information may contain a code unique to each wireless electrode assembly to command discharge of capacitor 125, along with more elaborate instructions controlling discharge parameters such as threshold voltage for firing, duration and shape of the discharge pulse, etc.

Using wireless electrode assemblies of the type shown in FIG. 3, all of the implanted wireless electrode assemblies 120 may be charged simultaneously by a single burst of an RF charging field from a transmitter antenna 60. Because back reaction of the wireless electrode assemblies 120 on the antenna 60 may be small, transmitter 50 (FIG. 1) losses may be primarily due to Ohmic heating of the transmit antenna 60 during the transmit burst, Ohmic heating of the receive coil 122, and Ohmic heating of conductive body tissues by eddy currents induced in these tissues by the applied RF magnetic field. By way of comparison, if eight wireless electrode assemblies 120 are implanted and each is addressed independently for charging, the transmitter 50 may be turned ON eight times as long, which may require almost eight times more transmit energy, the additional energy being primarily lost in heating of the transmit antenna 60 and conductive body tissues. With the wireless electrode assembly 120 of FIG. 3, however, all implanted wireless electrode assemblies can be charged simultaneously with a burst of RF current in

antenna **60**, and antenna and body tissue heating occurs only during the time required for this single short burst. Each wireless electrode assembly is addressed independently through its filter device **126** to trigger pacing. The transmitted trigger fields can be of much smaller amplitude, and therefore lose much less energy to Ohmic heating, than the transmitted charging pulse.

Pending U.S. patent application Ser. No. 10/971,550 (filed on Oct. 20, 2004), Ser. No. 11/075,375 (filed on Mar. 7, 2005), and Ser. No. 11/075,376 (filed on Mar. 7, 2005), all owned by the assignee of this application, describe various features of wireless electrode assemblies, systems to deliver the wireless electrode assemblies to the heart, and electronic components to activate the wireless electrode assemblies to deliver electrical stimulation. It should be understood from the description herein that some of the features described in these three patent applications (Ser. Nos. 10/971,550, 11/075,375, and 11/075,376) may be applicable to particular embodiments described herein.

Referring now to FIG. 4, some embodiments of an electrode delivery system **100** may include a guide catheter **110** and a delivery catheter **115**. The catheters **110** and **115** may comprise an elongate body that extends from a proximal end (outside the patient's body, not shown in FIG. 4) to a distal end (depicted in FIG. 4 as extending into the patient's heart **30**). The delivery catheter **115** fits within a lumen of the guide catheter **110**, and can be advanced through the guide catheter **110** so that a distal end of the delivery catheter **115** extends out of a distal opening of the guide catheter **110**. The guide catheter **110** may be directed through one or more veins or arteries to the targeted chamber of the heart (e.g., the left ventricle **34** is the targeted chamber in the embodiment shown in FIG. 4). The guide catheter **110** may comprise a steering mechanism (e.g., steering wires, shape memory device, or the like) to shift the distal end and may include at least one marker band **112** to permit viewability of the distal end of the guide catheter **110** using medical imaging techniques. Such a marker band **112** may aid a physician when steering the guide catheter **110** to the targeted heart chamber.

After the guide catheter **110** is deployed into the targeted heart chamber, the wireless electrode assemblies **120** may be advanced into the heart tissue through the guide catheter **110** using at least one delivery catheter **115**. The wireless electrode assemblies **120** may be consecutively delivered through the guide catheter **110** using at least one delivery catheter **115**. In some embodiments, the delivery catheter **115** may include at least one marker band **116** to permit viewability of the distal end of the delivery catheter **115** using medical imaging techniques. The delivery catheter **115** may include a steering mechanism (e.g., steering wires, shape memory device, or the like) to shift the distal end. For example, the delivery catheter **115** may comprise a shape memory device (e.g., one or more wires comprising Nitinol or another shape memory material) to provide a predetermined curvature near the distal end of the delivery catheter **115**. The shape memory device may be activated by a change in electrical charge or by a change in temperature. In one example, the delivery catheter **115** may include a shape memory device near the distal end that is capable of providing a 90-degree deflection curve near the distal end immediately before a longitudinally straight section at the distal end of the catheter **115**.

In some approaches to the targeted tissue, the steering mechanism (e.g., steering wires, shape memory device, or the like) of the delivery catheter **115** can be manipulated so that a deflected portion near the distal end of the delivery

catheter abuts against the septum wall of the targeted heart chamber. For example, the deflected portion of the delivery catheter may abut against the septum wall **39** between the left ventricle **34** and the right ventricle **38** while a longitudinally straight section of the catheter **115** extends the distal end against the targeted heart chamber wall to receive the wireless electrode assembly **120** (refer to the dotted-line example depicted in FIG. 4). Accordingly, the deflected portion of the delivery catheter **115** can abut against the septum wall to support the position of the distal end of the delivery catheter **115** during the deployment of the wireless electrode assembly **120** into the targeted heart tissue **35** (refer, for example, to FIGS. 7A-D and 8). Such an approach may provide leverage and stability during the insertion process for the electrode assembly **120**.

The delivery catheter **115** includes an opening at the distal end in which an associated wireless electrode assembly **120** is retained in a loaded position. The wireless electrode assembly **120** may include a body portion that has a length and a radius configured to be retained with the delivery catheter **115**. As described in more detail below, some embodiments of the body portion of the wireless electrode assembly **120** may have a radius, for example, of about 1.25 mm or less and may have a length, for example, of about 10 mm or less. Wireless electrode assemblies configured for insertion into an atrial wall may be smaller than those configured for insertion into the ventricle walls.

In the exemplary embodiment shown in FIG. 4, the wireless electrode assemblies **120** comprise a pointed-tip cylindrical body having a forward portion embedded within the heart wall tissue and a rearward portion that is inside the heart chamber but not fully embedded in the heart wall tissue. The pointed distal tip **130** of the electrode assembly **120** facilitates penetration into the heart wall tissue, and the proximal end of the electrode assembly is configured to remain outside of the heart wall. However, in some embodiments, both the distal tip **130** and the proximal end of the electrode assembly **120** can be embedded within the heart wall tissue **30**. As described in more detail below, the electrode assembly **120** may include two fixation devices **132** and **134** that generally oppose one another, such as a set of distal tines and a set of proximal tines. The distal tines can be coupled to and extend from a periphery of a forward portion of the body of the electrode assembly **120**, and the proximal tines can be coupled to and extend from a periphery of a rearward portion of the body. As described in more detail below, the set of distal tines extend somewhat outwardly from the body of the electrode assembly **120** but also rearwardly so as to prevent the electrode from becoming dislodged from the heart wall once the electrode assembly **120** is implanted. Also as described in more detail below, the set of proximal tines extend somewhat outwardly from the body of the electrode assembly **120** but also forwardly so as to prevent the electrode assembly **120** from penetrating entirely through the heart wall.

As the wireless electrode assembly **120** is deployed from delivery catheter **115**, tines **132** and **134** located externally on the wireless electrode assembly **120** may adjust to a deployed position (e.g., an outwardly extended condition). Such an adjustment to the deployed position may be caused, for example, due to spring bias of the tines **132** and **134** (described in more detail below). When the tines **132** and **134** are in the deployed position, the tines **132** and **134** are capable of securing the wireless electrode assembly **120** to the targeted tissue site (e.g., described in more detail below, for example, in connection with FIGS. 7-8). In some embodiments, the opening at the distal end of the delivery

catheter **115** may be part of conduit that extends through the elongated body of the catheter **115**. In other embodiments, the opening at the distal end of the delivery catheter **115** may extend only a partial length into the delivery catheter **115** (e.g., with a narrower channel extending fully to the proximal end of the delivery catheter **115** to provide space for the plunger mechanism **140**).

Referring to FIGS. **5** and **6**, the tines **132** and **134** of the wireless electrode assembly **120** may be configured in a number of orientations. For example, the tines **132** and **134** can be arranged in a configuration (refer to FIG. **5**) that permits the electrode assembly **120** to penetrate a substantial length into the heart wall tissue (described in more detail below in connection with FIGS. **7A-7D**). In another example, the tines **132** and **134** can be arranged in a configuration (refer to FIG. **6**) that permits the electrode assembly **120** to penetrate a lesser amount into the heart wall tissue (described in more detail below in connection with FIG. **8**). In some embodiments, wireless electrode assembly **120** may include a proximal electrode **121** at or near a proximal end and a distal electrode **129** at or near a distal end. The proximal electrode **121** and distal electrode **129** may provide bipolar electrode capabilities for the wireless electrode assembly **120**, thereby permitting the assembly **120** to supply an electrical charge between the proximal and distal electrodes **121** and **129** (and across the nearby heart tissue).

As previously described, the fixation device **132** may include a set of biased tines arranged near the distal end of the wireless electrode assembly **120** so as to secure the wireless electrode assembly **120** to the heart chamber wall. The fixation device **134** may include a first set of biased tines arranged near the proximal end of the wireless electrode assembly **120** which can also serve to secure the assembly **120** to the heart chamber wall. In some embodiments, the tines **134** arranged near the proximal end may have a different configuration and orientation from the opposing tines **132** arranged near the distal end. For example, as shown in the embodiments depicted in FIGS. **5-6**, the distal tines **132** may generally oppose the proximal tines **134**. In these circumstances, at least some of the tines **132** and **134** are biased to adjust from a loaded condition to a deployed condition. For example, when in the loaded condition, the tines **132** and **134** may be arranged generally along the body **128** of the wireless electrode assembly **120** so as to fit within the cavity at the distal end of the delivery catheter **115** (refer, for example, to FIG. **7A**). The tines **132** and **134** may be biased to adjust to the deployed condition while advancing from the delivery catheter **115**. When in the deployed condition, the distal tines **132** may be disposed in an outwardly extended orientation that opposes the outwardly extended orientation of the proximal tines **134**. In one example, the distal tip **130** may penetrate into the heart chamber wall when a force is applied to the wireless electrode assembly **120** (e.g., penetrate the endocardium and possibly into the myocardium). During penetration, the tines **132** and **134** are biased to transition from the loaded condition (described in more detail below in connection with FIGS. **7A-D**) to the deployed condition as illustrated by tines **132a** and **134a** (in FIG. **5**) and tines **132b** and **134b** (in FIG. **6**). Such a configuration permits the wireless electrode assembly **120** to be readily secured to the heart chamber wall after advancing from the delivery catheter **115**.

As previously described, the wireless electrode assembly **120** may be arranged in the delivery catheter **115** (FIG. **4**) so that the tines **132** and **134** are in a loaded condition. Thus, when the electrode assembly **120** is advanced out of the

distal end of the delivery catheter **115**, the tines **132** and **134** transition into their respective deployed conditions. In some embodiments, the tines **132** and **134** may comprise biocompatible material that is capable of flexing from the loaded condition to the deployed condition. For example, one or more of the tines **132** and **134** may comprise a shape memory alloy (e.g., Nitinol or the like), stainless steel, titanium, metal alloys (e.g., nickel-cobalt base alloys such as MP35N), composite materials, or the like.

In the embodiment depicted in FIG. **5**, the distal tines **132a** and proximal tines **134a** can be arranged so that a substantial length of the electrode assembly **120** penetrates into the heart wall tissue. In these circumstances, the distal tines **132a** may penetrate in the heart wall tissue to hinder rearward migration of the electrode assembly **120** back into the heart chamber, and the proximal tines **134a** are configured to abut or partially penetrate into the wall surface to hinder forward migration of the assembly **120** toward the outside of the heart. Thus, when in the deployed condition, the distal tines **132a** oppose migration of the wireless electrode assembly **120** in the generally proximal direction and the proximal tines **134a** oppose migration in the generally distal direction. Accordingly, the opposing orientation of the tines **132a** and **134a** secures the wireless electrode assembly **120** to the heart tissue in a manner so that a portion of the proximal end of the wireless electrode assembly **120** is not embedded in the heart tissue. Because tines **132a** and **134a** can retain the electrode assembly **120** in the heart tissue without substantial migration, the proximal end of the electrode assembly body **128** can be incorporated into the surrounding heart tissue over a period of days or weeks. In these embodiments, the wireless electrode assembly **120** may be immobilized by the surrounding tissue to prevent future dislodgement. In such circumstances, the patient may receive anti-coagulants, Aspirin, or other drugs (e.g., PLAVIX, CUMODIN, etc.) for several months after the operation or until incorporation of the wireless electrode assembly **120** into the surrounding tissue has occurred.

In this embodiment depicted in FIG. **5**, the distal tines **132a** and the proximal tines **134a** are slightly curved and are oriented in an opposing manner when in the deployed condition. The curvature of the proximal tines **132** is such that the tines **134a** contact the surface of the heart tissue near the proximal tines' extremities. In addition, the proximal tines **134a** can be positioned along the body **128** and curved in a manner so that the free end **135a** of each proximal tine **134a** abuts or partially penetrates into the heart wall tissue after a portion of the electrode assembly **120** has penetrated therein. The wireless electrode assembly **120** can be advanced into the heart wall tissue **35** so that the proximal tines **134a** cause a slight spring-back action after abutting or partially penetrating into the heart wall tissue. For example, the proximal tines **134a** may flex outwardly when forced into engagement with the heart wall tissue, and such an outward flexing action can cause a slight spring back motion to the wireless electrode assembly **120**. The distal tines **132a** may flex outwardly in response to this slight spring-back motion in the proximal direction, thereby enhancing the engagement of the heart tissue between the distal tines **132a** and the proximal tines **134a**.

Still referring to FIG. **5**, the proximal tines **134a** can be positioned along the body **128** and curved in a manner so that the free end **135a** of each proximal tine **134a** abuts or partially penetrates into the heart wall tissue after a substantial portion of the electrode assembly **120** has penetrated therein. For example, in this embodiment, the proximal tines **134a** are configured such that the free end **135a** of each tine

**134a** (when in the deployed condition) is disposed a longitudinal distance  $D_1$  rearward of the distal tip **130**. In this embodiment, the longitudinal distance  $D_1$  is greater than half the overall length  $L$  of the electrode assembly **120**. In such circumstances, a majority of the length of the electrode assembly **120** can penetrate into the heart wall tissue before the proximal tines **134a** engage the heart wall to oppose forward migration. This example of substantial penetration of the electrode assembly **120** into the heart wall tissue may be effective when advancing the electrode assembly **120** into portions of the heart having thicker myocardial walls (e.g., some heart walls around the left and right ventricles). In addition, when a substantial portion of the electrode assembly **120** penetrates into the heart tissue, the non-penetrating proximal portion of the electrode assembly **120** is reduced, thereby promoting efficient healing and incorporation into the surrounding heart tissue.

In the embodiment depicted in FIG. 6, the distal tines **132b** and proximal tines **134b** can be arranged on that a lesser length of the electrode assembly **120** penetrates into the heart wall tissue. For example, the distal tines **132b** may be substantially different in length than the proximal tines **134b**. Also, the proximal tines **134b** may have a greater curvature than the proximal tines **134a** previously described in connection with FIG. 5 so that the contact between the surface of the heart tissue and the proximal tines is near the apex of the curvature. In these embodiments, the proximal tines **134b** can be positioned along the body **128** and curved in a manner so that the curvature apex **135b** of each proximal tine **134b** abuts the heart wall tissue after a partial length of the electrode assembly **120** has penetrated therein. For example, the proximal tines **134b** are configured such that the apex **135b** (when in the deployed condition) is disposed at a longitudinal distance  $D_2$  rearward of the distal tip **130**. In this embodiment, the longitudinal distance  $D_2$  is about half the overall length  $L$  of the electrode assembly **120**. Accordingly, about half of the electrode assembly **120** can penetrate into the tissue before the proximal tines **134b** oppose forward migration. Such penetration to a limited length of the electrode assembly **120** may be effective when advancing the electrode assembly **120** into portions of the heart wall having a reduced wall thickness (e.g., some heart walls around the right atrium).

As previously described, the tines **132b** and **134b** are oriented in an opposing fashion to secure the wireless electrode assembly **120** to the heart tissue in a manner that opposes reward migration and forward migration, thereby permitting incorporation into the surrounding tissue. For example, the proximal tines **134b** may flex outwardly when forced against the heart wall tissue, and such an outward flexing action can cause a slight spring back motion to the wireless electrode assembly **120**. The distal tines **132b** may flex outwardly in response to this slight spring-back motion in the proximal direction, thereby enhancing the engagement of the heart tissue between the distal tines **132b** and the proximal tines **134b**.

In some embodiments, the proximal tines **134b** of the electrode assembly may be nonaligned with the distal tines **132b** along the body of the electrode assembly **128**. For example, as shown in FIG. 6, the distal tines **132b** may be tangentially shifted about  $45^\circ$  along the body circumference as compared to the proximal tines **134b** so that the proximal tines **134b** and distal tines **132b** are nonaligned. As described in more detail below in connection with FIG. 8, such nonalignment between the proximal tines **134b** and the distal tines **132b** can permit one set of tines (e.g., the proximal tines **134b**) to partially deploy before fully exiting the distal

opening of the delivery catheter **115**. In these circumstances, the partial deployment of the proximal tines **134b** before fully exiting the delivery catheter **115** can facilitate the abutting engagement between the proximal tines **134b** and the heart chamber wall.

It should be understood that in some embodiments of the wireless electrode assembly **120**, the distal tines **132** may also serve as at least a portion of the distal electrode **129**. Also, in some embodiments, proximal tines **134** may also serve as at least a portion of the proximal electrode **121**. For example, the tines **132** and **134** may comprise an electrically conductive material (e.g., stainless steel or another metallic material) and may be electrically connected to the distal and proximal electrode circuitry (respectively).

Referring now to FIGS. 7A-D, some embodiments of the wireless electrode assemblies **120** may be press fit into the conduit of the delivery catheter **115** so that a plunger mechanism **144** may be used to separate the wireless electrode assembly **120** from the delivery catheter **115**. As shown in FIG. 7A, the delivery catheter **115** may be steered and directed toward a targeted site at the surface of heart tissue **35** (e.g., a heart chamber wall). The delivery catheter **115** may contain at least a distal portion of a tube portion **142** that is coupled to an actuation rod **140**. As previously described, in some approaches to the targeted tissue, the steering mechanism (e.g., steering wires, shape memory device, or the like) of the deliver catheter **115** can be manipulated so that a deflected portion near the distal end of the delivery catheter **115** abuts against the septum wall of the targeted heart chamber. For example, the portion **117** (FIG. 7A) of the delivery catheter **115** may be deflected to abut against the septum wall while a longitudinally straight section of the catheter **115** extends toward the targeted heart tissue **35**. As such, some portion (e.g., portion **117**) the delivery catheter **115** can abut against the septum wall to support the position of the distal end of the delivery catheter **115**.

The wireless electrode assembly **120** may be releasably engaged with the tube portion **142**. For example, the wireless electrode assembly **120** may be press-fit into the tube portion **142**. In another example, the tube portion **142** may have a square cross-sectional shape, a hexagonal cross-sectional shape, a keyed cross-sectional shape, or other noncircular cross-sectional shape to engage the complementary shaped body of the wireless electrode assembly **120**. The tube portion **140** may be substantially rigid so as to retain the fixation devices **132** and **134** of the wireless electrode assembly **120** in a loaded condition (as shown, for example, in FIG. 7A). In some embodiments, one or both of the actuation rod **140** and the plunger mechanism **144** may extend to an actuation device (e.g., a hand-operated trigger mechanism) at the proximal end of the delivery catheter **115** outside the patient's body. In some embodiments, the tube portion **142** and the actuation rod **140** may be fixedly arranged in the delivery catheter **115** so as to deliver one electrode assembly at a time. Alternatively, the tube portion **142** and the actuation rod **140** may be movable through lumen of the delivery catheter **115** so that a number of electrode assemblies can be consecutively passed through the delivery catheter **115**.

As shown in FIG. 7B, the distal end of the delivery catheter **115** may abut the surface of the heart tissue **35** to prepare the wireless electrode assembly **120** for fixation to the tissue **35**, in this embodiment, the distal end of the delivery catheter **115** includes a marker band **116** to facilitate the steering and guidance of the delivery catheter (e.g., a

physician may employ medical imaging techniques to view the marker band 116 while the delivery catheter 115 is in the heart 30).

Referring to FIG. 7C, the electrode assembly 120 can be advanced through the distal opening of the delivery catheter 115 (and the tube portion 142) and into the tissue 35. This operation may be performed by advancing the plunger mechanism 144 against the proximal end of the wireless electrode assembly 120 to thereby force the distal tip 130 of the wireless electrode assembly 120 to penetrate through the endocardium and possibly into the myocardium. For example, the force may be applied by manipulating the actuation device (e.g., the hand-operated trigger mechanism connected to the proximal end of the plunger mechanism 144) to force the plunger mechanism 144 in the distal direction relative to the actuation rod 140 (and the tube portion 142). As such, the distal tip 130 of the electrode assembly 120 pierces the tissue surface and advances into the tissue 35.

Referring to FIG. 7D, when the delivery catheter 115 is fully separated from the wireless electrode assembly 120, the fixation devices 132 and 134 can transition from a loaded condition to a deployed condition. In this embodiment, the fixation devices 132 and 134 comprise tines that are biased to the deployed condition (refer, for example, to FIGS. 5-6) after being released from the tube portion 142 of the delivery catheter 115. As previously described in connection with FIG. 5, the tines 132 and 134 can be configured so that a substantial portion of the electrode assembly 120 penetrates into the tissue 35 before the forward migration is hindered by the proximal tines 134. For example, the electrode assembly 120 can penetrate the longitudinal length  $D_1$  into the heart tissue 35 so that a majority of the overall length of the electrode assembly 120 is advanced into the tissue 35. In these embodiments, the distal tines 132a can transition to the deployed condition in which each tine 132a is outwardly extended in a generally proximal direction when the distal tip 130 penetrates into the heart tissue 35. Also in these embodiments, the proximal tines 134a can transition to the deployed condition in which each tine 134a is extended outwardly in a generally distal direction when the delivery catheter 115 is separated from the proximal end of the wireless electrode assembly 120. The proximal tines 134a have a base 150 affixed to the body of electrode assembly 120.

As previously described, in some circumstances, the proximal tines 134a may flex outwardly when forced against the heart wall tissue, and such an outward flexing action can cause a slight spring back motion to the wireless electrode assembly 120. The distal tines 132a may flex outwardly in response to this slight spring-back motion in the proximal direction, thereby enhancing the engagement of the heart tissue 35 between the distal tines 132a and the proximal tines 134a. Such an opposed orientation of the tines 132a and 134a hinders rearward migration and forward migration of the electrode assembly 120. As previously described, the tissue 35 may grow and eventually incorporate the wireless electrode assembly 120 therein, thereby preventing the wireless electrode assembly 120 from dislodgement from the tissue 35. In the example depicted in FIG. 7D, the proximal tines 134a are illustrated as abutting against the heart tissue 35. It should be understood that, in some embodiments, the proximal tines 134a may at least partially penetrate into the heart tissue 35 when the electrode assembly 120 is advanced therein.

Referring to FIG. 8, other embodiments of the wireless electrode assembly 120 include fixation devices 132 and 134

that transition into different configurations. For example, the fixation devices 132b and 134b may include tines that are biased to transition into a deployed condition (after being released from the delivery catheter 115) as described in connection with FIG. 6. In such embodiments the tines 132b and 134b may deploy to outwardly extended orientations that generally oppose one another. The tines 132 and 134 can be configured so that a limited length of the electrode assembly 120 penetrates the tissue 35 before the forward migration is opposed by the proximal tines 134b (e.g., before the curvature apex 135b abuts the tissue 35). For example, the electrode assembly 120 can penetrate the longitudinal length  $D_2$  into the heart tissue 35 so that about half of the overall length of the electrode assembly 120 is advanced into the tissue 35. As previously described, in some circumstances, the proximal tines 134b may flex outwardly when forced against the heart wall tissue 35, and such an outward flexing action can cause a slight spring back motion to the wireless electrode assembly 120. The distal tines 132b may flex outwardly in response to this slight spring-back motion in the proximal direction, thereby enhancing the engagement of the heart tissue 35 between the distal tines 132b and the proximal tines 134b. Such opposed orientations of the tines 132b and 134b hinders rearward and forward migration of the electrode assembly 120. Also, as previously described, the tissue 35 may grow and eventually incorporate the wireless electrode assembly 120 therein, thereby preventing the wireless electrode assembly 120 from dislodgement from the tissue 35.

Still referring to FIG. 8, the proximal tines 134b may be configured to at least partially deploy before exiting the distal opening of the delivery catheter 115. As such, the proximal tines 134b may at least partially curve outwardly from the body 128 of the electrode assembly before contacting the heart wall tissue 35. In these circumstances, the proximal tines 134b may curve so as to abut against the heart wall tissue 134b without the extremities of the proximal tines 134b penetrating into the tissue 35. Because the proximal tines 134b can at least partially deploy before exiting the distal opening of the delivery catheter 115, the proximal tines 134b can achieve the greater curvature previously described in connection with FIG. 6 so that the contact between the heart tissue 35 and the proximal tines 134b is near the curvature apex 135b (FIG. 6).

For example, in some embodiments, electrode assembly 120 can be arranged in the tube portion 142 so that the proximal tines 134b are aligned with deployment slots 146 (FIG. 8) formed in the tube portion 142. Accordingly, when the electrode assembly is advanced into the heart tissue 35, the proximal tines 134b at least partially extend outwardly into the deployment slots 146, thereby permitting the proximal tines 134b to partially deploy before exiting the distal opening of the delivery catheter 115. As previously described in connection with FIG. 6, the proximal tines 134b may be nonaligned with the distal tines 132b along the body of the electrode assembly 128. Such nonalignment between the proximal tines 134b and the distal tines 132b can permit the proximal tines 134b to partially deploy in the deployment slots 146 while the distal tines 132b are retained against the electrode body 128 in the tube portion 142. Alternatively, the distal tines 132b can be generally aligned with the proximal tines 134b so that both the distal tines 132b and the proximal tines 134b pass through the deployment slots 146 during advancement of the electrode assembly 120 from the delivery catheter 115. It should be understood that, in some embodiments, the deployment slots 146 may extend through the distal circumferential end of the

delivery catheter **115** so that the proximal tines **134b** can at least partially deploy through the distal circumferential end of the delivery catheter **115** before exiting the distal opening of the delivery catheter **115**.

In some embodiments of the delivery catheter **115** described herein, the delivery catheter **115** may be wholly separate from the actuation rod **140** so that the actuation rod **140** slides through a conduit passing through the delivery catheter **115**. In such circumstances, the actuation rod **140** may be completely retracted from the delivery catheter so that a second wireless electrode assembly may be detachably coupled to the actuation rod **140** (or to an unused, different actuation rod **140**) and then directed through the delivery catheter **115** already disposed in the patient's body. In other embodiments, the delivery catheter **115** and the actuation rod **140** may be coupled to one another. In such circumstances, the delivery catheter **115** and actuation rod **140** may be removed from the guide catheter **110** (FIG. 4) so that a second wireless electrode assembly may be detachably coupled to the actuation rod **140** for to a previously unused delivery catheter/actuation rod having a similar construction) and then directed through the guide catheter **110** already disposed in the patient's body.

In some embodiments, the delivery catheter **115** may include a tube portion that is configured to retain a plurality of wireless electrode assemblies **120** (e.g., similar to tube portion **142** but having a greater length to receive a multitude of assemblies **120**). For example, the delivery catheter may be configured to carry two, three, four, five, ten, twelve, or more electrode assemblies **120** in a serial (end to end) arrangement. As such, the plunger mechanism **144** can be used to force each electrode assembly **120** into different tissue sites without retracting the delivery catheter out of the heart. As described previously, the actuation mechanism may force the plunger **144** in a generally distal direction. In the serially arranged embodiment, the plunger **144** applies the force to the most rearward assembly **120** in the serial arrangement, which in turn applies a force from the distal tip **130** of the most rearward assembly **120** to the proximal end of the next assembly **120** in the serial arrangement. In this fashion, the application of force can propagate through the serial arrangement until the assembly **120** nearest the heart tissue is delivered to the target site (as described previously, for example, in connection with FIG. 7D). It should be understood that the serial arrangement may comprise electrode assemblies **120** as described in connection with FIG. 5, as described in connection with FIG. 6, or some combination thereof.

Some of the embodiments described herein permit a plurality of pacing electrodes to be deployed at multiple pacing sites. The pacing sites may be located in the left atrium **32**, the left ventricle **34**, the right atrium **36**, the right ventricle, or a combination thereof. Furthermore, the pacing electrodes may comprise wired pacing leads **95** (FIG. 1), wireless electrode assemblies, or a combination thereof. Providing electrical stimulation at multiple pacing sites and in multiple heart chambers may be used to treat a number of conditions. One such condition is congestive heart failure (CHF). It has been found that CHF patients have benefited from hi-ventricular pacing, that is, pacing of both the left ventricle **34** and the right ventricle **38** in a timed relationship. It is believed that many more patients could benefit if multiple sites in the left and right ventricles **34** and **36** could be synchronously paced. In addition, pacing at multiple sites may be beneficial where heart tissue through which electrical energy must propagate is scarred or dysfunctional, which condition halts or alters the propagation of an electrical

signal through that heart tissue. In these cases multiple-site pacing may be useful to restart the propagation of the electrical signal immediately downstream of the dead or sick tissue area. Synchronized pacing at multiple sites on the heart may inhibit the onset of fibrillation resulting from slow or aberrant conduction, thus reducing the need for implanted or external cardiac defibrillators. Arrhythmias may result from slow conduction or enlargement of the heart chamber. In these diseases, a depolarization wave that has taken a long and/or slow path around a heart chamber may return to its starting point after that tissue has had time to re-polarize. In this way, a never ending "race-track" or "circus" wave may exist in one or more chambers that is not synchronized with normal sinus rhythm. Atrial fibrillation, a common and life threatening condition, may often be associated with such conduction abnormalities. Pacing at a sufficient number of sites in one or more heart chambers, for example in the atria, may force all tissue to depolarize in a synchronous manner to prevent the race-track and circus rhythms that lead to fibrillation.

A number of embodiments of the invention have been described. Nevertheless, it will be understood that various modifications may be made without departing from the spirit and scope of the invention. Accordingly, other embodiments are within the scope of the following claims.

The invention claimed is:

1. A system, comprising:

a wireless electrode assembly comprising:

a body;

an electrode to electrically stimulate tissue, the electrode immovably fixed to the body;

a circuit coupled to the electrode and configured to deliver to the electrode electrical energy to stimulate the tissue, the circuit housed within the body; and wherein the body is sized and shaped for percutaneous delivery into contact with heart wall tissue, the body including a proximally-located portion and a fixation device configured to securely anchor the wireless electrode assembly to a tissue site;

wherein the wireless electrode assembly is configured to be securely anchored to the tissue site using the fixation device in response to user manipulation of the wireless electrode assembly using a first elongate member configured to engage the proximally-located portion of the body of the wireless electrode assembly;

wherein the fixation device comprises a curved tine biased to shift from a loaded configuration to an outwardly extending configuration, wherein in the loaded configuration, the curved tine is oriented in a distal direction, wherein the curved tine includes a base immovably fixed to the body in both the loaded configuration and the outwardly extending configuration;

wherein in the outwardly extending configuration, the curved tine includes a first region extending from the base in a distal direction and a second region extending in a proximal direction to a tip of the curved tine, the first and second regions separated by an apex of curvature, wherein the curved tine is configured to engage the heart wall tissue and hinder migration of the wireless electrode assembly; and

wherein the base of the curved tine and the electrode both remain immovably fixed to the body while the curved tine shifts from the loaded configuration to the outwardly extending configuration.

2. The system of claim 1, further comprising the first elongate member; and a second elongate member defining a lumen;

wherein the first elongate member comprises an actuator rod sized and shaped to deliver the wireless electrode assembly to the tissue site through the lumen; and wherein the curved tine is oriented in the distal direction while located within the lumen defined by the second elongate member.

3. The system of claim 1, wherein the proximally-located portion of the body of the wireless electrode assembly comprises a keyed cross-sectional shape configured to be engaged by the first elongate member.

4. The system of claim 3, further comprising the first elongate member;

wherein the first elongate member includes an interior tubular wall comprising one or more respective slots configured to engage one or more respective keyed portions comprising the keyed cross sectional shape of the body of the wireless electrode assembly; and wherein the first elongate member is configured to rotate the body of the wireless electrode assembly using the engagement of the one or more respective keyed portions in response to user rotation of the first elongate member.

5. The system of claim 4, wherein the fixation device comprises at least one tine extending from the body;

wherein the body of the wireless electrode assembly comprising the keyed cross-sectional shape includes the tine extending from the body; and

wherein the tine is sized and shaped to be engaged by a corresponding slot in the interior tubular wall of the first elongate member.

6. The system of claim 1, wherein the body of the wireless electrode assembly comprises a polygonal shape and wherein the first elongate member is configured to engage the polygonal shape.

7. The system of claim 6, wherein the polygonal shape includes a hexagonal shape.

8. The system of claim 1, wherein the electrode is sized and shaped for insertion into myocardial tissue.

9. The system of claim 1, wherein at least one of the body or the electrode, is sized and shaped to conically taper to a sharp tip, located at a forward distal end of the wireless electrode assembly, to permit penetration and insertion into the heart wall.

10. The system of claim 1, wherein the wireless electrode assembly is configured to provide electrical energy to the electrode in response to a wireless signal from a transmitter configured to sense cardiac electrical activity, the wireless transmitter at a different location than the wireless electrode assembly and outside the heart.

11. The system of claim 1, wherein the circuit comprises: an internal coil configured to inductively couple with a wireless transmitter located at a different location than the wireless electrode assembly; and

an electrical charge storage device configured to be charged by current inductively generated by the internal coil.

12. The system of claim 1, wherein the wireless electrode assembly is configured to provide electrical energy to the electrode in response to a wireless signal from a transmitter configured to sense cardiac electrical activity, the transmitter located at a different location than the wireless electrode assembly and outside the heart.

13. The system of claim 1, wherein the wireless electrode assembly comprises an intravascularly-deliverable wireless electrode assembly sized and shaped to fit entirely within a heart; and

wherein the heart wall includes an inner heart wall.

14. The system of claim 1, wherein the fixation device is configured to partially deploy before the wireless electrode assembly fully exits a distal opening of a lumen defined by a second elongate member through which the wireless electrode assembly is configured to be delivered.

15. The system of claim 1, wherein the curved tine includes a rectangular cross section.

16. A method, comprising:

delivering an intravascularly-deliverable wireless electrode assembly to a tissue site via an intravascular route using a first intravascularly-deliverable elongate member configured to engage a proximally-located portion of the intravascularly-deliverable wireless electrode assembly, the intravascularly-deliverable wireless electrode assembly comprising:

a body;

an electrode to electrically stimulate tissue, the electrode immovably fixed to the body;

a circuit coupled to the electrode and configured to deliver to the electrode electrical energy to stimulate the tissue, the circuit housed within the body; and

wherein the body is sized and shaped for percutaneous transluminal delivery into contact with inner heart wall tissue via an intravascular route and to fit entirely within a heart, the body including a fixation device configured to securely anchor the wireless electrode assembly to a tissue site; and

securely anchoring the intravascularly-deliverable wireless electrode assembly to the tissue site using the fixation device in response to user manipulation of the wireless electrode assembly, using the first intravascularly-deliverable elongate member;

wherein the fixation device comprises a curved tine biased to shift from a loaded configuration to an outwardly extending configuration, wherein in the loaded configuration, the curved tine is oriented in a distal direction, wherein the curved tine includes a base immovably fixed to the body in both the loaded configuration and the outwardly extending configuration;

wherein the outwardly extending configuration, the curved tine includes a first region extending from the base in a distal direction and a second region extending in a proximal direction to a tip of the curved tine, the first and second regions separated by an apex of a curvature, wherein the curved tine is configured to engage the heart wall tissue and hinder migration of the wireless electrode assembly; and

wherein the base of the curved tine and the electrode both remain immovably fixed to the body while the curved tine shifts from the loaded configuration to the outwardly extending configuration.

17. The method of claim 16, comprising partially deploying the fixation device before the wireless electrode assembly fully exits a distal opening of a lumen defined by a second elongate member through which the wireless electrode assembly is delivered.

18. An implantable medical device for implanting in a heart chamber, comprising:

a wireless electrode assembly including:

a body member having a proximal end and a distal end and a length measured from the proximal end to the distal end, the body member being configured to be positioned entirely within a chamber of a heart;

an electrode immovably fixed to the distal end of the body member;

a circuit positioned within the body member, the circuit electrically coupled to the electrode to delivery electrical energy to the electrode to stimulate cardiac tissue; and

a plurality of tines, configured to engage cardiac tissue, 5 wherein each of the plurality of tines has a base portion immovably fixed to the body member and a tip opposite the base portion, wherein each of the plurality of tines is biased to move from a constrained, loaded configuration in which the base 10 portion is immovably fixed to the body member and the tip of each of the plurality of tines is pointed distally to an unconstrained, curved configuration in which the base portion is immovably fixed to the body member and the tip of each of the plurality of 15 tines is pointed proximally; wherein in the unconstrained, curved configuration, the curved tine engages the heart wall tissue and hinders migration of the wireless electrode assembly; and 20 wherein the base portion of the curved tine and the electrode both remain immovably fixed to the body while the curved tine shifts from the loaded configuration to the unconstrained configuration.

\* \* \* \* \*

25

|                |  |         |            |
|----------------|--|---------|------------|
| 专利名称(译)        | 心脏刺激系统   |         |            |
| 公开(公告)号        | <a href="#">US10022538</a>   | 公开(公告)日 | 2018-07-17 |
| 申请号            | US14/044094  | 申请日     | 2013-10-02 |
| [标]申请(专利权)人(译) | 心脏起搏器股份公司  |         |            |
| 申请(专利权)人(译)    | 心脏起搏器, INC.  |         |            |
| 当前申请(专利权)人(译)  | BOSTON SCIENTIFIC SCIMED, INC.   |         |            |
| [标]发明人         | DRASLER WILLIAM J<br>PIKUS MICHAEL J<br>HASTINGS ROGER<br>SMITH SCOTT R<br>LAFONTAINE DANIEL M<br>SAHOLT DOUGLAS R<br>KVEEN GRAIG L<br>WILLARD MARTIN R                |         |            |
| 发明人            | DRASLER, WILLIAM J.<br>PIKUS, MICHAEL J.<br>HASTINGS, ROGER<br>SMITH, SCOTT R.<br>LAFONTAINE, DANIEL M.<br>SAHOLT, DOUGLAS R.<br>KVEEN, GRAIG L.<br>WILLARD, MARTIN R. |         |            |
| IPC分类号         | A61N1/05 A61B5/00 A61B5/042 A61N1/368 A61N1/372 A61N1/375  |         |            |
| CPC分类号         | A61N1/059 A61B5/6848 A61B5/6882 A61N1/0573 A61N1/37205 A61B5/042 A61N1/3684 A61N1/3756 A61B5/0031 A61N1/36843  |         |            |
| 优先权            | 60/748964 2005-12-09 US  |         |            |
| 其他公开文献         | US20140039591A1  |         |            |
| 外部链接           | <a href="#">Espacenet</a>  |         |            |

摘要(译)

起搏系统的一些实施例采用无线电极组件来提供起搏治疗。无线电极组件可以通过电感耦合无线地接收能量，以便向周围的心脏组织提供电刺激。在某些实施例中，无线电极组件可包括一个或多个偏置的尖齿，其从第一位置移位到第二位置以将无线电极组件固定到心腔的内壁中。

