



US 20190143130A1

(19) **United States**

(12) **Patent Application Publication**
Maile et al.

(10) **Pub. No.: US 2019/0143130 A1**

(43) **Pub. Date: May 16, 2019**

(54) **COMMUNICATIONS IN A MEDICAL
DEVICE SYSTEM WITH LINK QUALITY
ASSESSMENT**

A61N 1/362 (2006.01)

A61B 5/00 (2006.01)

A61N 1/375 (2006.01)

A61N 1/39 (2006.01)

(71) Applicant: **CARDIAC PACEMAKERS, INC.**, St.
Paul, MN (US)

H04B 13/00 (2006.01)

A61B 5/02 (2006.01)

A61B 5/08 (2006.01)

A61B 5/11 (2006.01)

(72) Inventors: **Keith R. Maile**, New Brighton, MN
(US); **Brendan E. Koop**, Ham Lake,
MN (US); **Brian L. Schmidt**, White
Bear Lake, MN (US); **Michael J.
Kane**, St. Paul, MN (US); **Jacob M.
Ludwig**, Isanti, MN (US); **Jeffrey E.
Stahmann**, Ramsey, MN (US); **Lance
E. Juffer**, Lino Lakes, MN (US)

(52) **U.S. Cl.**

CPC *A61N 1/37288* (2013.01); *A61N 1/37247*
(2013.01); *A61N 1/362* (2013.01); *A61B*
5/0024 (2013.01); *A61B 5/7221* (2013.01);
A61B 5/6869 (2013.01); *A61N 1/37252*
(2013.01); *A61B 5/0028* (2013.01); *A61N*
1/3756 (2013.01); *A61N 1/3962* (2013.01);
H04B 13/005 (2013.01); *A61B 5/0002*
(2013.01); *A61B 5/02* (2013.01); *A61B 5/08*
(2013.01); *A61B 5/11* (2013.01); *A61N*
1/37217 (2013.01); *A61N 1/3727* (2013.01);
A61N 1/37205 (2013.01); *A61B 5/024*
(2013.01)

(73) Assignee: **CARDIAC PACEMAKERS, INC.**, St.
Paul, MN (US)

(21) Appl. No.: **16/247,304**

(22) Filed: **Jan. 14, 2019**

Related U.S. Application Data

(63) Continuation of application No. 15/070,013, filed on
Mar. 15, 2016, now Pat. No. 10,213,610.

(60) Provisional application No. 62/134,726, filed on Mar.
18, 2015.

Publication Classification

(51) **Int. Cl.**

A61N 1/372 (2006.01)

A61B 5/024 (2006.01)

(57)

ABSTRACT

Methods and devices for testing and configuring implantable
medical device systems. A first medical device and a second
medical device communicate with one another using test
signals configured to provide data related to the quality of
the communication signal to facilitate optimization of the
communication approach. Some methods may be performed
during surgery to implant one of the medical devices to
ensure adequate communication availability.

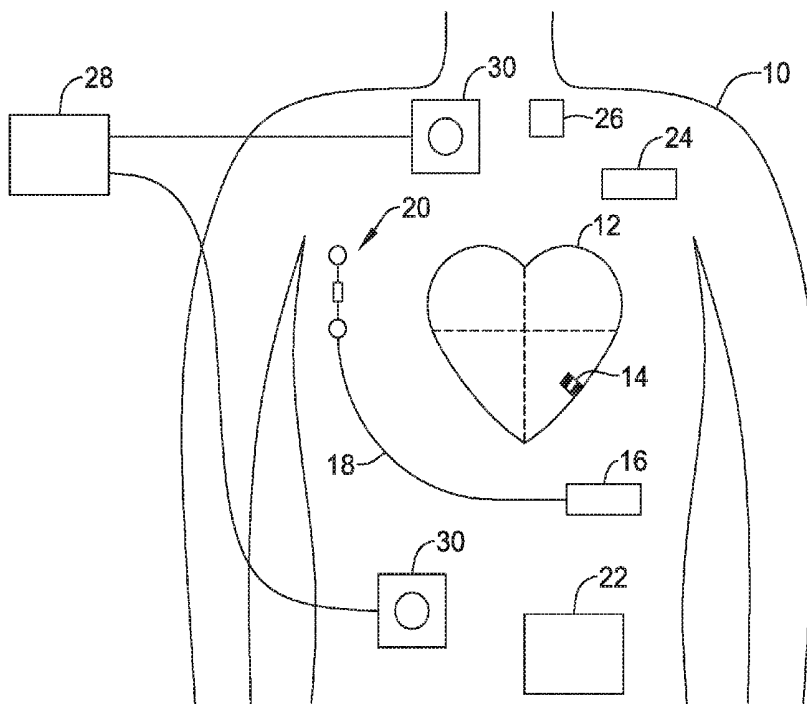

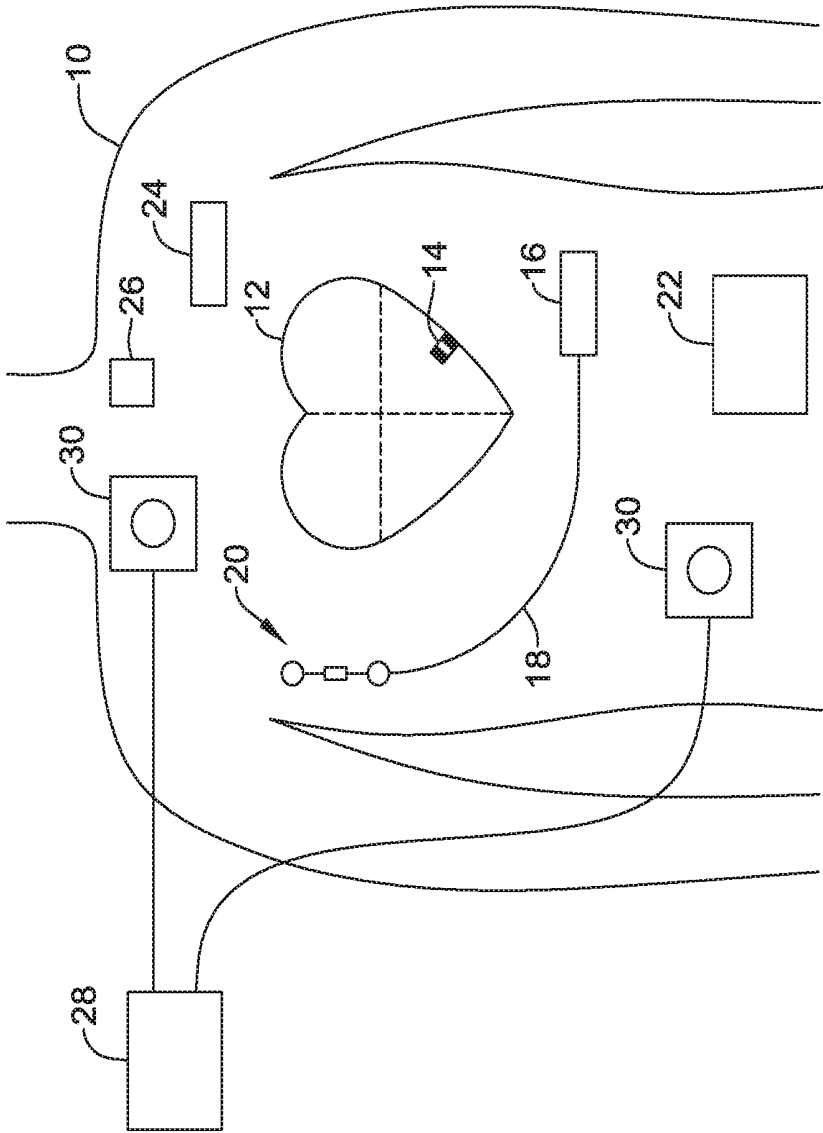

FIG. 1

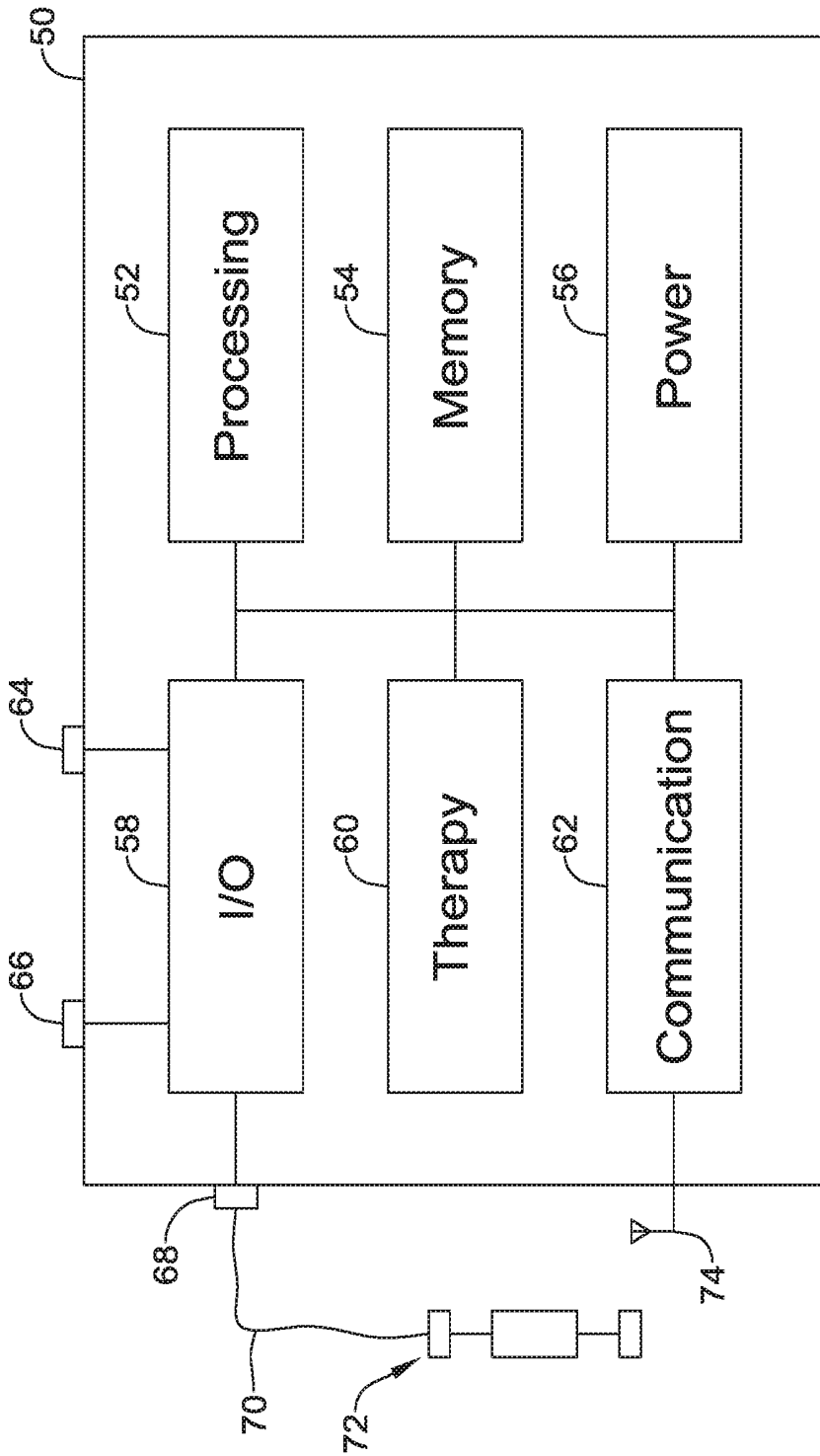

FIG. 2

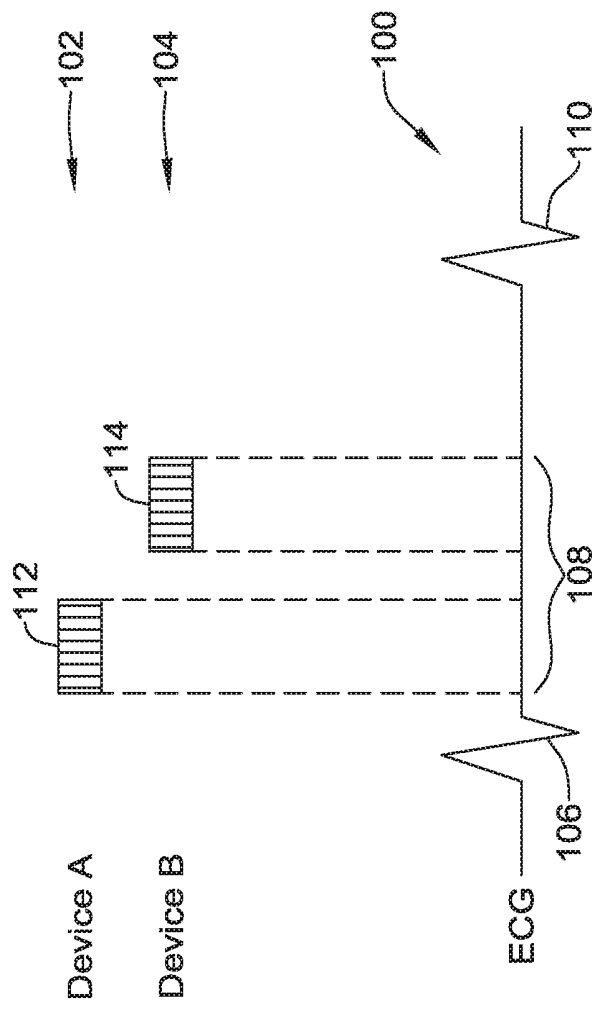

FIG. 3

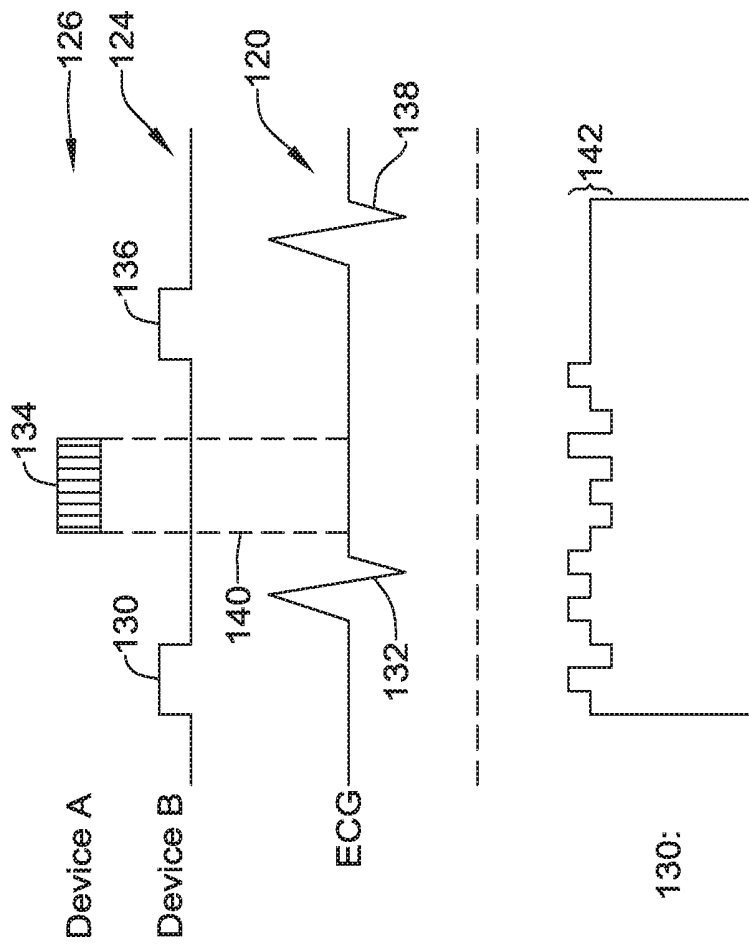

FIG. 4

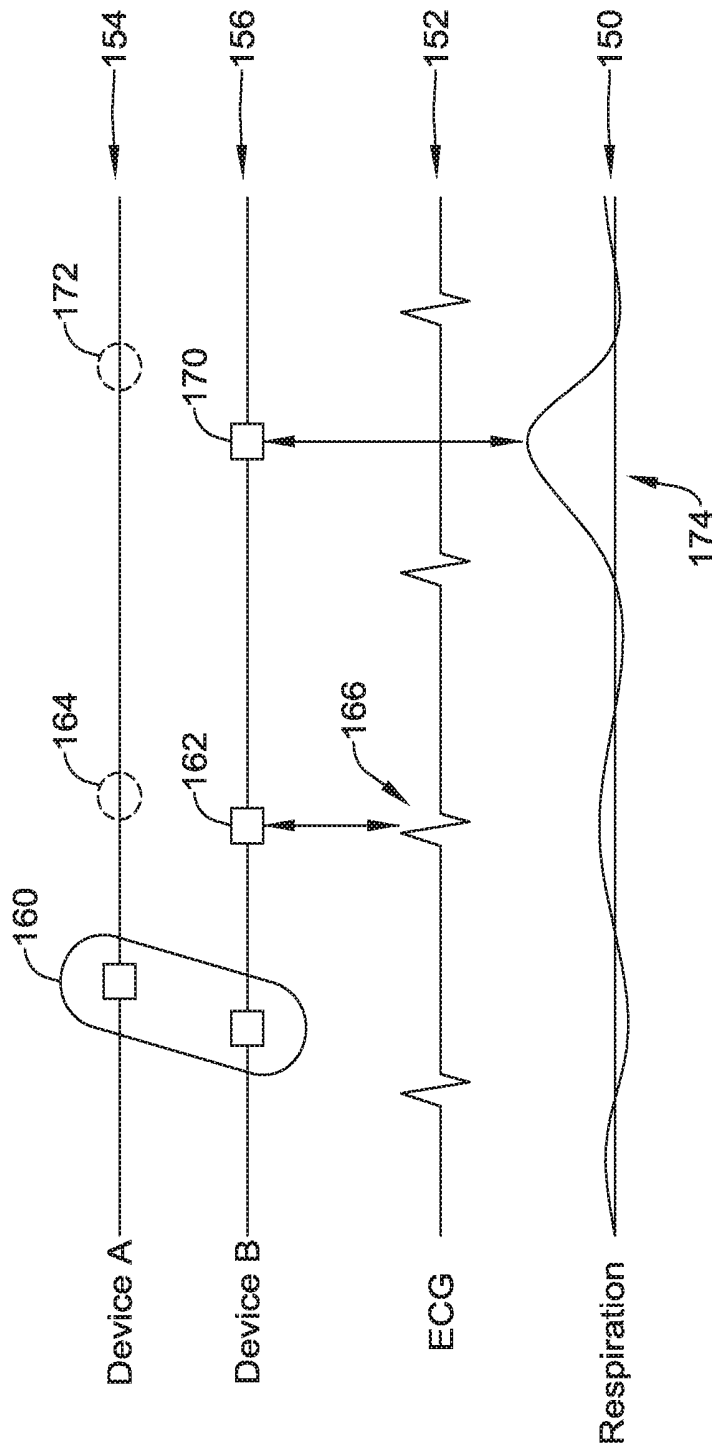

FIG. 5

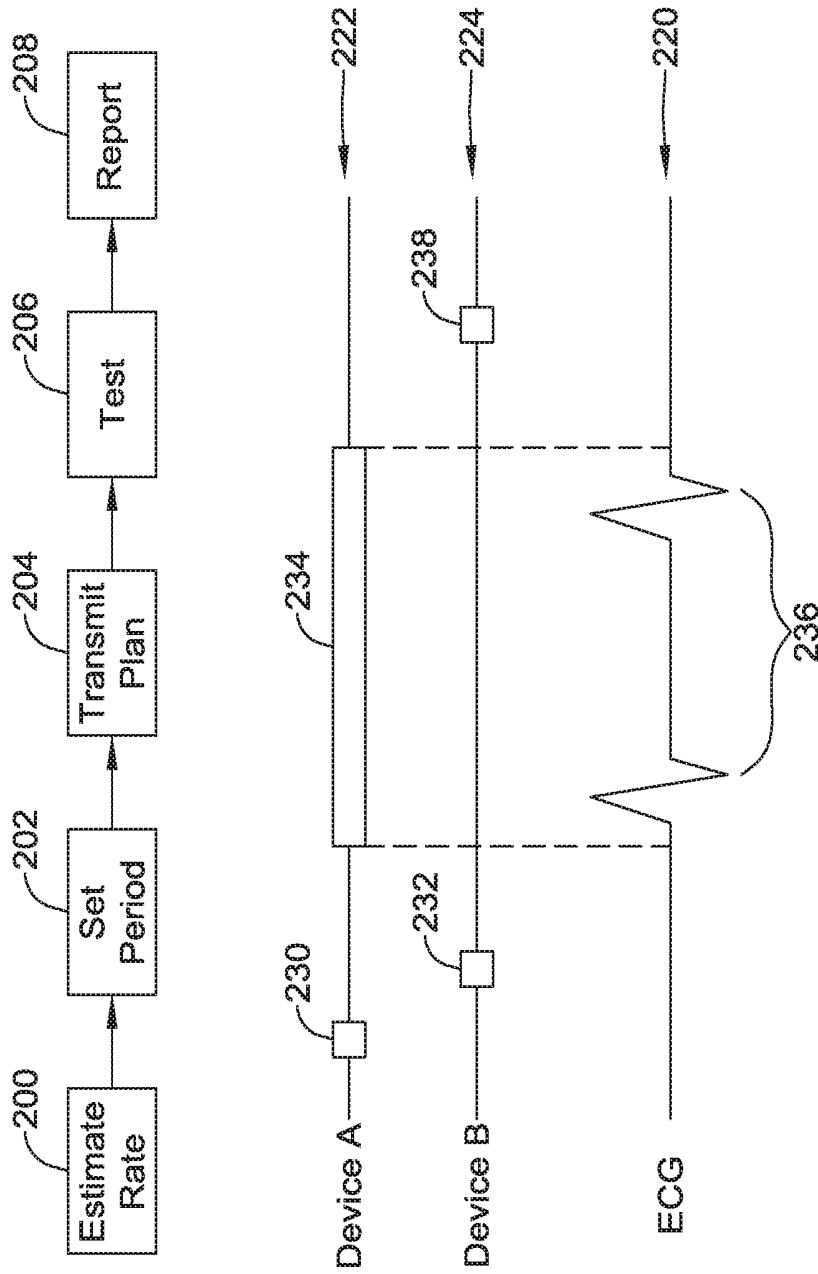

FIG. 6

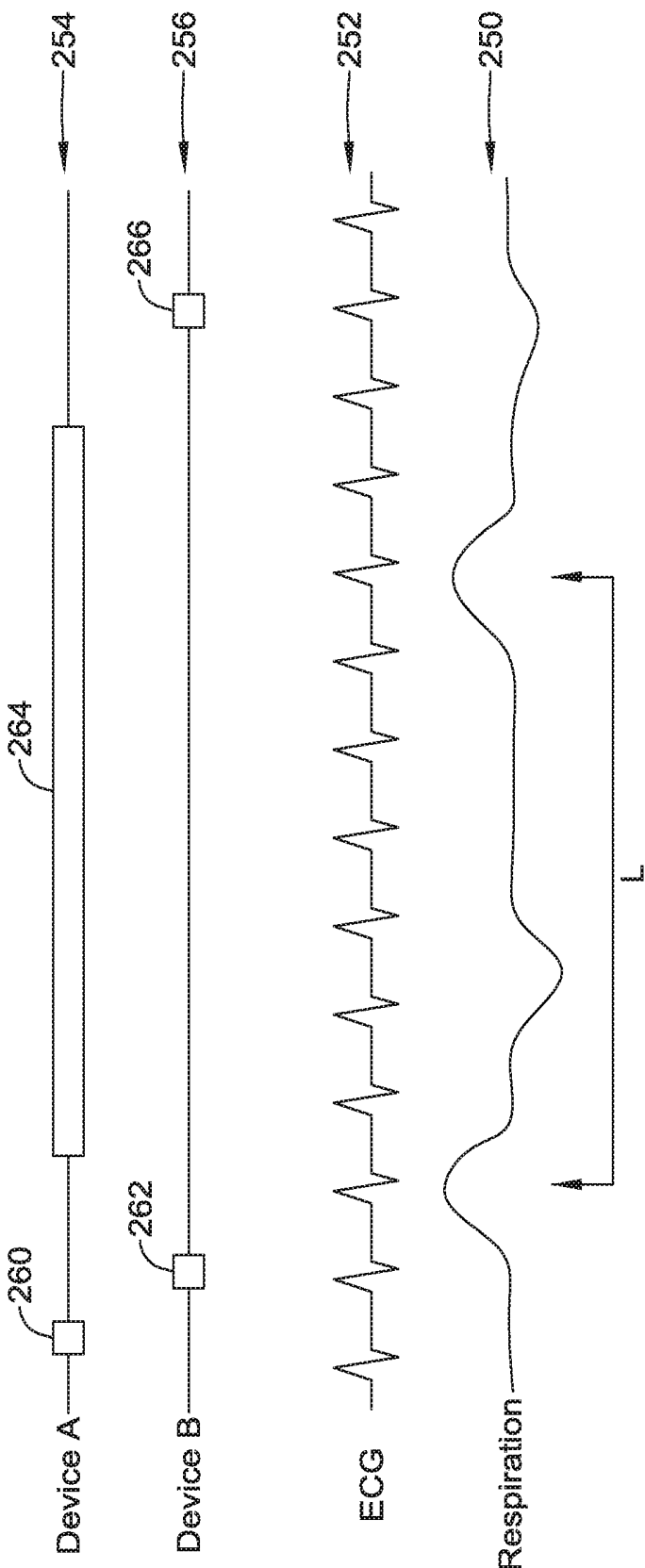

FIG. 7

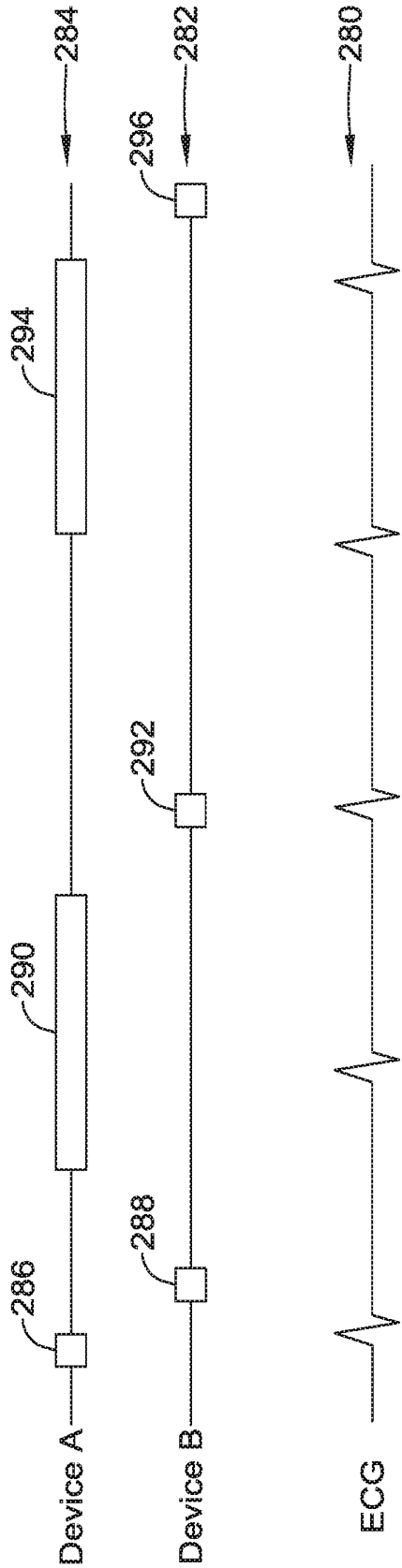

FIG. 8

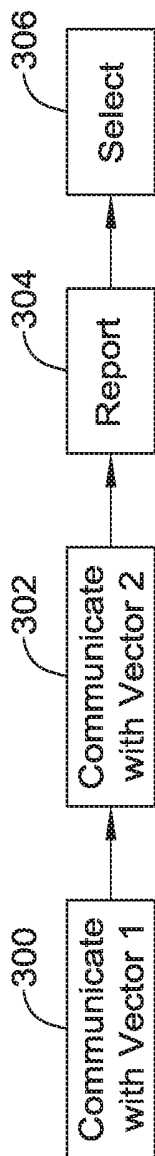

FIG. 9

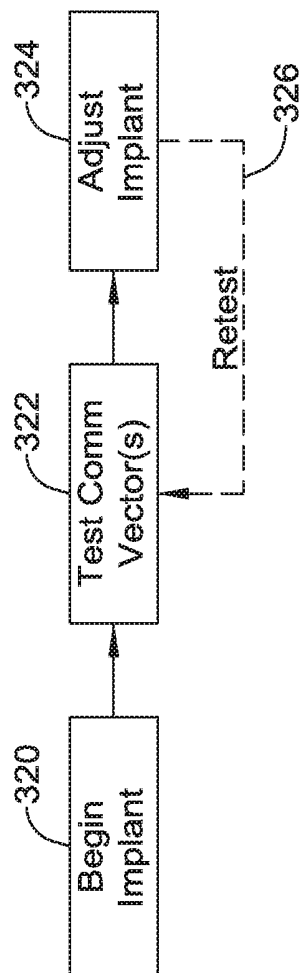

FIG. 10

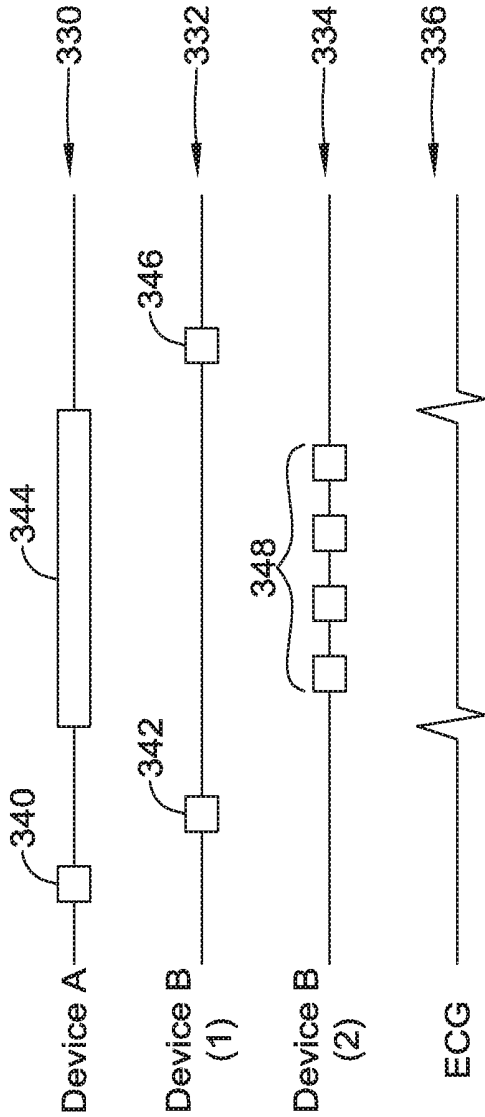

FIG. 11

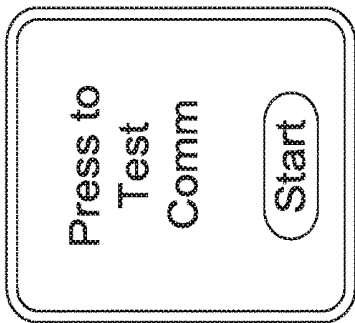

FIG. 12A

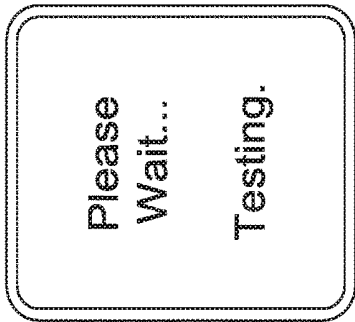

FIG. 12B

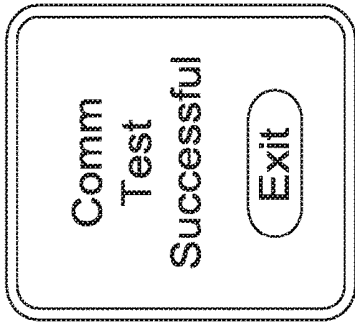

FIG. 12C

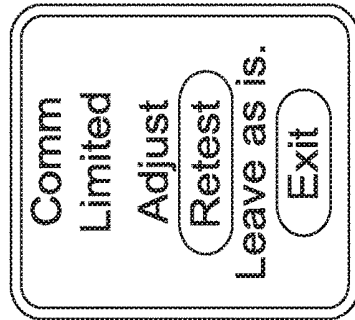

FIG. 12D

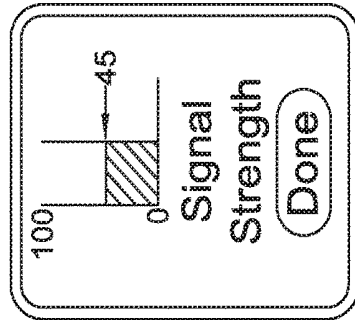

FIG. 12E

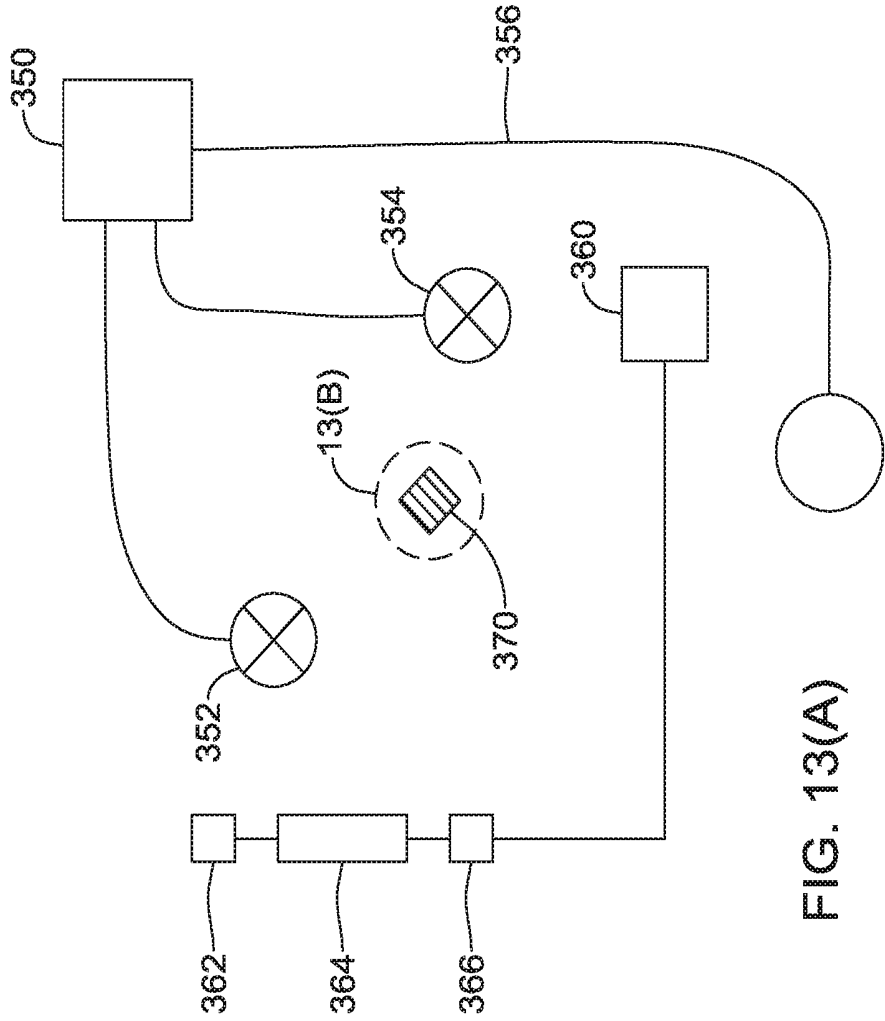

FIG. 13(A)

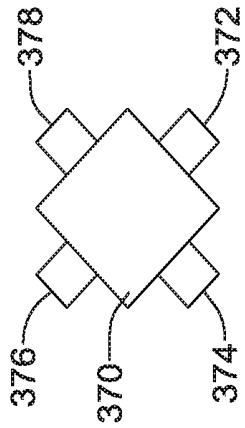

FIG. 13(B)

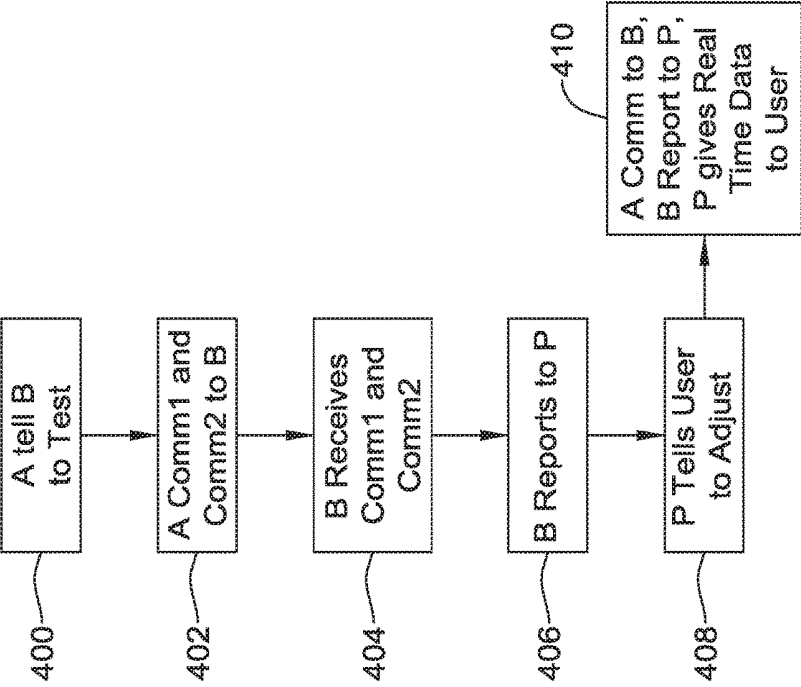

FIG. 14

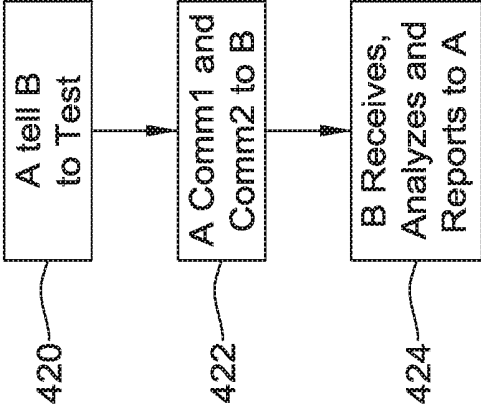

FIG. 15

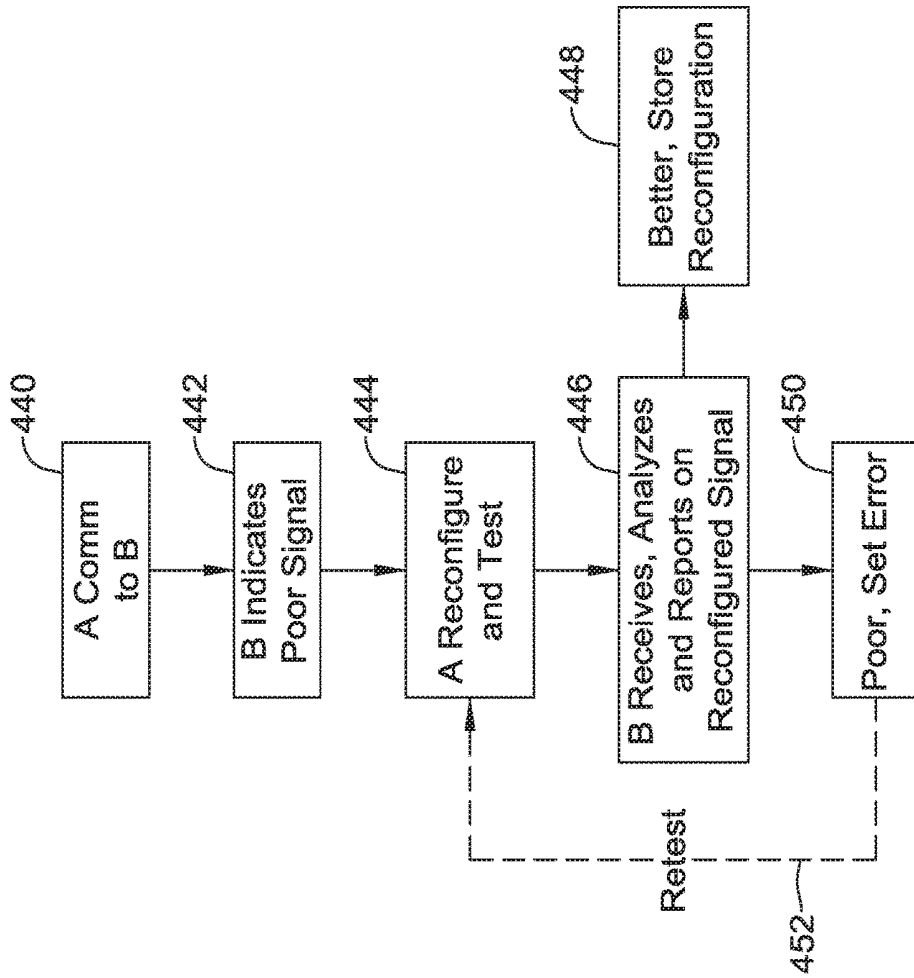

FIG. 16

COMMUNICATIONS IN A MEDICAL DEVICE SYSTEM WITH LINK QUALITY ASSESSMENT

CROSS REFERENCE TO RELATED APPLICATIONS

[0001] This application is a continuation of U.S. patent application Ser. No. 15/070,013, filed Mar. 15, 2016, which claims the benefit of and priority to U.S. Provisional Patent Application No. 62/134,726, filed Mar. 18, 2015, the disclosures of which are incorporated herein by reference.

TECHNICAL FIELD

[0002] The present disclosure generally relates to medical devices, and more particularly to communications between implantable medical devices.

BACKGROUND

[0003] Various active implantable devices are available or in development for treating and/or diagnosing numerous ailments. Some examples include cardiac assist devices, pacemakers, defibrillators, cardiac monitors, neurostimulation and neuromodulation systems, drug and medication pumps, and others. A patient may have multiple implanted devices and may benefit in some circumstances by enabling such devices to communicate with one another. Because these implantable devices are generally reliant on battery power, communication between devices should be designed for efficiency and to limit power consumption.

SUMMARY

[0004] The present disclosure relates generally to systems and methods for managing communication strategies using link quality assessment.

[0005] A first example is an implantable medical device comprising means for communicating by conducted communication with at least a second implantable medical device; means for setting the means for communicating into a continuing receive mode for analyzing a first signal received from the second implantable medical device and a second signal received from the second implantable medical device; means for analyzing the first signal and the second signal as received by the means for communicating; and means for generating an output communication indicating a result of the analysis of the first signal and the second signal.

[0006] A second example takes the form of the implantable medical device of the first example, wherein the means for analyzing the first signal and the second signal is operable by receiving and analyzing a biological signal from a patient to identify events in the biological signal to generate a marker set; and annotating the first signal and the second signal using the marker set.

[0007] A third example takes the form of the implantable medical device of the second example, wherein the biological signal is a cardiac signal and the events are components of the cardiac cycle.

[0008] A fourth example takes the form of the implantable medical device of any of the first three examples, wherein the continuing receive mode includes a period for receiving at least one of the first signal and the second signal for a duration which exceeds a recurring biological cycle of a patient. A fifth example takes the form of the implantable medical device of the fourth example wherein the recurring

biological cycle is a cardiac cycle. A sixth example takes the form of the implantable medical device of the fourth example wherein the recurring biological cycle is a respiration cycle.

[0009] A seventh example takes the form of the implantable medical device of any of the first six examples wherein the means for generating an output communication is operable to generate an output communication signaling: a preference for the first signal; a preference for the second signal; or an indication that neither of the first signal nor the second signal is suitable.

[0010] An eighth example takes the form of a medical system comprising an implantable medical device as in the seventh example and an external programmer for communication with the implantable medical device, the external programmer including a user interface, wherein the implantable medical device means for generating an output communication is operable to send an output communication for receipt by the external programmer; and wherein the external programmer is configured to indicate to a user if the implantable medical device generated an indication that neither of the first signal nor the second signal is suitable, and to suggest that the user modify the position of the implantable medical device.

[0011] A ninth example takes the form of a system as in the eighth example wherein the implantable medical device and external programmer are configured to communicate in real-time to indicate to the physician changes to a conducted communication signal received by the implantable medical device as the implantable medical device position is adjusted by the physician.

[0012] A tenth example takes the form of a medical system comprising a first implantable medical device as in the seventh example, a second implantable medical device, and an external programmer for communication with at least one of the first and second implantable medical devices, wherein the first implantable medical device is configured to receive the first signal and the second signal from the second implantable medical device and generate the output communication for receipt by the second implantable medical device, and the second implantable medical device is configured to communicate to the external programmer.

[0013] An eleventh example takes the form of a medical system comprising a first implantable medical device as in the seventh example and a second implantable medical device configured to generate conducted communication signals to the first implantable medical device, the second implantable medical device comprising at least first, second and third electrodes for generating the conducted communication to yield at least first and second conducted communication vectors, wherein the second implantable medical device is configured to generate the first signal using a first conducted communication vector, and to generate the second signal using a second conducted communication vector.

[0014] A twelfth example takes the form of a medical system comprising a first implantable medical device as in any of the first six examples, a second implantable medical device, and an external programmer for communication with the first and second implantable medical devices, wherein the first implantable medical device is configured to receive the first and second signals from the second implantable medical device and generate the output communication to the external programmer.

[0015] A thirteenth example takes the form of a medical system as in any of the tenth to twelfth examples wherein the first implantable medical device is configured as a leadless cardiac pacemaker for implantation entirely within the heart of a patient, and the second implantable medical device is configured as a subcutaneous-only implantable defibrillator.

[0016] A fourteenth example takes the form of the implantable medical device of any of the first seven examples further comprising therapy circuitry for providing pacing output and wherein the implantable medical device is configured as a leadless cardiac pacemaker for implantation entirely within the heart of a patient.

[0017] A fifteenth example takes the form of an implantable medical device comprising means for communicating by conducted communication with at least a second implantable medical device, at least first, second and third electrodes configured for conducted communication with the second implantable medical device such that at least first and second conducted communication vectors are available for use by the communication means, means for setting the means for communicating to a continuing transmit mode for using the first conducted communication vector to generate an output, and then using the second conducted communication vector to generate an output; means for determining, from information provided back to the implantable medical device, which, if any, of the first conducted communication vector and second conductive communication vector is to be used for delivering conducted communication messages to the second implantable medical device; and means for setting a default conducted communication vector for use by the means for communicating.

[0018] A sixteenth example is a method of performing a diagnostic test in an implantable medical device system comprising: generating a first conducted signal from a first medical device intended for receipt by a second medical device comprising an output pattern for a selected period; receiving the conducted signal by a second medical device and calculating a parameter of the first conducted signal as received; wherein the selected period exceeds an expected or detected length of a recurring biological cycle.

[0019] A seventeenth example takes the form of a method as in the sixteenth example, wherein the recurring biological cycle is a cardiac cycle. An eighteenth example takes the form of a method as in the sixteenth example wherein the recurring biological signal is a respiration cycle.

[0020] A nineteenth example takes the form of a method as in any of the sixteenth to eighteenth examples wherein the first medical device comprises at least three electrodes configured to output a conducted signal and the first conducted signal is generated by a first combination of electrodes, the method further comprising generating a second conducted signal using a second combination of electrodes, receiving the second conducted signal and calculating the parameter for the second conducted signal. A twentieth example takes the form of a method as in the nineteenth example, further comprising comparing the parameter as calculated for the first conducted signal as received to the parameter as calculated for the second conducted signal.

[0021] A twenty-first example is a method comprising performing a method as in any of the sixteenth to twentieth examples while a patient assumes a first posture, and repeating the same method while the patient assumes a second posture.

[0022] A twenty-second example is a method of configuring communication between implantable medical devices comprising: in a first implantable device having a plurality of electrodes configured for outputting a conducted signal, generating a first conducted signal using a selected pair of electrodes; in a second implantable device, receiving and analyzing the first conducted signal; in the second implantable device, communicating a second signal related to an outcome of the analysis of the first conducted signal while the first conducted signal is being received.

[0023] A twenty-third example takes the form of a method as in the twenty-second example, further comprising receiving the second signal in the first implantable device while the first conducted signal is still being generated. A twenty-fourth example takes the form of a method as in either of the twenty-second or twenty-third examples, wherein the second signal is a conducted signal received by the first implantable device using a different pair of electrodes than the pair used for generating the first conducted signal. A twenty-fifth example takes the form of a method as in either of the twenty-second or twenty-third examples, wherein the second signal is not a conducted signal. A twenty-sixth example takes the form of a method as in the twenty-second example, further comprising receiving the second signal with an external medical device configured for communication with at least one of the first implantable device and the second implantable device.

[0024] A twenty-seventh example is a method of configuring communication between implantable medical devices during an implantation procedure of a first medical device in a patient in whom a second medical device is already implanted, the method comprising: during an implantation procedure for the first medical device, testing communication between the first medical device and the second medical device; determining that communication is suboptimal; and in response to determining that communication is suboptimal, adjusting an orientation of the first medical device.

[0025] A twenty-eighth example takes the form of a method as in the twenty-seventh example, wherein at least one of the first medical device and the second medical device is configured for communication with an external programmer, the method further comprising obtaining a feedback signal from the external programmer which indicates in real time a quality of a communication link between the first medical device and the second medical device.

[0026] A twenty-ninth example takes the form of a method as in either of the twenty-seventh or twenty-eighth examples wherein the first medical device is a leadless cardiac pacemaker and the second medical device is a subcutaneous implantable cardioverter defibrillator. A thirtieth example takes the form of a method as in either of the twenty-seventh or twenty-eighth examples wherein the first medical device is a leadless cardiac pacemaker (LCP) which is implanted by advancing an implantation catheter to a desired location and then securing the LCP at the desired location and decoupling the implantation catheter from the LCP, wherein the step of testing communication is performed while the LCP is coupled to the implantation catheter and before the LCP is secured at the desired location.

[0027] A thirty-first example is a method of operation in an implantable medical device system comprising an external programmer and first implantable medical device and a second implantable medical device, the method being configured for performance communication quality monitoring

during a procedure to implant the second medical device while the first medical device is already implanted, the method comprising: the first medical device generating a communication test signal prior to completion of placement of the second medical device during the procedure to implant the second medical device; the second medical device receiving and analyzing the communication test signal from the first medical device; the second medical device generating an output indicating a quality of the communication test signal as received; the programmer providing an indication to a physician performing the implantation procedure related to the quality of the communication test signal as received by the second medical device.

[0028] A thirty-second example takes the form of a method as in the thirty-first example wherein the step of the second medical device generating an output indicating a quality of the communication test signal comprises the second medical device communicating to the programmer in real time, such that the step of the programmer providing an indication is performed in real time. A thirty-third example takes the form of a method as in the thirty-first example, wherein the step of the second medical device generating an output indicating a quality of the communication test signal comprises the second medical device communicating back to the first medical device and the first medical device communicating to the programmer to facilitate the programmer providing the indication to the physician.

[0029] A thirty-fourth example takes the form of a method as in any of the thirty-first to thirty-third examples wherein the first and second medical devices are each leadless cardiac pacemakers. A thirty-fifth example takes the form of a method as in any of the thirty-first to thirty-third examples wherein the first medical device is a subcutaneous implantable cardioverter defibrillator and the second medical device is a leadless cardiac pacemaker.

[0030] The above summary is not intended to describe each embodiment or every implementation of the present disclosure. Advantages and attainments, together with a more complete understanding of the disclosure, will become apparent and appreciated by referring to the following description and claims taken in conjunction with the accompanying drawings.

BRIEF DESCRIPTION OF THE DRAWINGS

[0031] The disclosure may be more completely understood in consideration of the following description of various illustrative embodiments in connection with the accompanying drawings, in which:

[0032] FIG. 1 illustrates a patient having a plurality of implantable medical devices;

[0033] FIG. 2 illustrates a block diagram of an implantable medical device;

[0034] FIGS. 3-5 are diagrams illustrating communications signals relative to biological signals;

[0035] FIG. 6 illustrates a flow diagram and graphic for an illustrative method;

[0036] FIGS. 7 and 8 are diagrams illustrating communications signals and test signals relative to biological signals;

[0037] FIGS. 9-10 are flow diagrams for illustrative methods;

[0038] FIG. 11 is another diagram illustrating communications signals and test signals relative to biological signals;

[0039] FIGS. 12A-12E show programmer screens for an illustrative method;

[0040] FIGS. 13A-13B show an implanted system and a detail view of a particular device; and

[0041] FIGS. 14-16 are flow diagrams for additional embodiments.

[0042] While the disclosure is amenable to various modifications and alternative forms, specifics thereof have been shown by way of example in the drawings and will be described in detail. It should be understood, however, that the intention is not to limit aspects of the disclosure to the particular illustrative embodiments described. On the contrary, the intention is to cover all modifications, equivalents, and alternatives falling within the spirit and scope of the disclosure.

DESCRIPTION

[0043] The following description should be read with reference to the drawings in which similar elements in different drawings are numbered the same. The description and the drawings, which are not necessarily to scale, depict illustrative embodiments and are not intended to limit the scope of the disclosure.

[0044] FIG. 1 illustrates a patient having a plurality of implantable medical devices. A patient, **10** is shown having a leadless cardiac pacemaker (LCP) **14** implanted inside the heart **12**. A subcutaneous implantable defibrillator (SICD) **16** having a left axillary canister and lead **18** extending to electrodes **20** is also shown. The patient may also have an insulin pump **22**, a pain pump **24** for delivering pain medication to the shoulder, and/or a nerve stimulator **26** having a lead (not shown) extending to the neck or head.

[0045] Other devices could be substituted for those shown in FIG. 1, and the positions shown for each device are not intended to be limiting. Some additional or alternative examples include other pacemakers or defibrillators, such as those with transvenous, intracardiac, epicardial, or substernal electrodes, for example, a cardiac monitor, left ventricular assist device, spinal cord stimulator, vagus nerve stimulator, gastric electric stimulator, sacral nerve stimulator, and/or any other implantable medical device.

[0046] These various systems may be interrogated by an external device or a “programmer” **28**, which may optionally use one or more skin electrodes **30** to assist with communication to an implanted device. Skin electrodes **30** may be used for conducted communication with an implantable device. As used herein, conducted communication is communication via electrical signals which propagate via patient tissue and are generated by more or less ordinary electrodes. By using the existing electrodes, conducted communication does not rely on an antenna and an oscillator/resonant circuit having a tuned center frequency common to both transmitter and receiver.

[0047] For other communication approaches such as RF or inductive communication, the programmer **28** may instead use a programming wand or may have an antenna integral with the programmer **28** housing for communication. Though not shown in detail, the programmer **28** may include any suitable user interface, including a screen, buttons, keyboard, touchscreen, speakers, and various other features widely known in the art. It is unlikely a single patient **10** would have all of the different systems implanted as shown in FIG. 1. For purposes of the present invention, it is assumed that a patient may have at least two implantable

systems simultaneously, and it may be beneficial to facilitate communication between the at least two implantable systems. The mode for communication between two implanted systems may be conducted communication, though other approaches (optical, acoustic, inductive or RF, for example) could be used instead.

[0048] FIG. 2 illustrates a block diagram of an implantable medical device. The illustration indicates various functional blocks within a device 50, including a processing block 52, memory 54, power supply 56, input/output circuitry 58, therapy circuitry 60, and communication circuitry 62. The I/O circuitry 58 can be coupled to one or more electrodes 64, 66 on the device 50 housing, and may also couple to a header 68 for attachment to one or more leads 70 having additional electrodes 72. The communication circuitry 62 may be coupled to an antenna 74 for radio communication (such as Medradio, ISM, or other RF) and/or may couple via the I/O circuitry 58 to a combination of electrodes 64, 66, 72, for conducted communication.

[0049] The processing block 52 will generally control operations in the device 50 and may include a microprocessor or microcontroller and/or other circuitry and logic suitable to its purpose. Processing block 52 may include dedicated circuits or logic for device functions such as converting analog signals to digital data, processing digital signals, detecting events in a biological signal, etc. The memory block may include RAM, ROM, flash and/or other memory circuits for storing device parameters, programming code, and data related to the use, status, and history of the device 50. The power supply 56 typically includes one to several batteries, which may or may not be rechargeable depending on the device 50. For rechargeable systems there would additionally be charging circuitry for the battery (not shown).

[0050] The I/O circuitry 58 may include various switches or multiplexors for selecting inputs and outputs for use. I/O circuitry 58 may also include filtering circuitry and amplifiers for pre-processing input signals. In some applications the I/O circuitry will include an H-Bridge to facilitate high power outputs, though other circuit designs may also be used. Therapy block 60 may include capacitors and charging circuits, modulators, and frequency generators for providing electrical outputs. For devices such as insulin and drug pumps the therapy circuit 60 may include a pump or pump actuator coupled to a delivery system for outputting therapeutic material, rather than using the I/O circuitry 58 as would be typical for systems that generate an electrical therapy output.

[0051] Communications circuitry 62 may include a frequency generator/oscillator and mixer for creating output signals to transmit via the antenna 74. Some devices 50 may include a separate ASIC for the communications circuitry 62, for example. For devices using an inductive communication output, an inductive coil may be included. Devices may also use optical or acoustic communication approaches, and suitable circuits, transducers, generators and receivers may be included for these modes of communication as well or instead of those discussed above.

[0052] As those skilled in the art will understand, additional circuits may be provided beyond those shown in FIG. 2. For example, some devices 50 may include a Reed switch or other magnetically reactive element to facilitate magnet wakeup or reset of the device by a user. Some systems may omit one or more blocks, for example, an implantable

cardiac monitor can omit therapy block 60, and an LCP may exclude the header 68 for coupling to lead 70.

[0053] In several embodiments, the present invention is directed toward the management and optimization of conducted communication between two implanted medical devices. For example, an LCP may communicate with an SICD. The LCP may, for example, provide a detected heartbeat rate to the SICD in order to assist the SICD in making a therapy determination. In another example, the SICD may request status from the LCP or may direct the LCP to deliver pacing pulses.

[0054] Other combinations of systems may use conducted communication between implants for various reasons. For example, if a patient has both a drug pump and a spinal cord stimulator, the drug pump may communicate to the spinal cord stimulator that it is in need of servicing, such that both systems may use their internal annunciating mechanisms to alert the patient that the drug pump requires service. As integrated systems develop, it may become possible to develop simplified devices that omit, for example, standard telemetry or annunciator circuits, and instead use conducted communication to another implant that includes full telemetry and annunciator circuits. If telemetry and/or annunciator circuits are omitted in one or more devices, the devices may become smaller and power consumption may be reduced. Thus conducted communication optimization may facilitate development of smaller and/or longer lasting devices in addition to facilitating inter-device coordination for therapy purposes.

[0055] FIGS. 3-5 are schematic diagrams illustrating communications signals relative to biological signals. Conducted communication takes place within the body, and so it is subject to interference from various biological functions. Respiration and the cardiac cycle are two particular biological functions of interest, though any other biological function, cyclic or not, may also be addressed using the methods and devices herein. FIG. 3 illustrates an ECG signal at 100, and communications by Device A at 102 and Device B at 104. The ECG shows a QRS complex (a heartbeat) at 106 followed by an interval 108, and another beat at 110. In this illustration, Device A sends a data packet 112 during the interval between beats 106, 110, and Device B responds with a packet at 114. The phrase "data packet" is used for convenience and should be understood as generically including any type of message/frame structure; no particular structure, type of data, size or other meaning should be implied.

[0056] In FIG. 3, the communication packets are shown as being sent independent of therapy output by either Device A or Device B. FIG. 4 shows another scheme in which Device B is configured to embed communications in a therapy output. The ECG is shown at 120, and the therapy output of Device B is shown at 124, while the to communications from Device A are shown at 126. The therapy output 124 includes pacing pulses 130 and 136, which trigger beats 132 and 138 respectively on the ECG 120.

[0057] A detail view of pacing pulse 130 is shown below, and it is seen at 142 that the shape of the pacing pulse 130 includes amplitude modulation embedding a data packet. Other approaches to embedding information in a pacing pulse can be used; the illustration is simplified in FIG. 4 since the present invention is not limited to any specific manner of embedding data.

[0058] In the example of FIG. 4, Device A is designed to recognize the data 142 embedded in the pacing pulse 130. In this example, Device A responds with a data packet at 134 following the end of the QRS complex of beat 132. In an alternative, Device A could send data packet 134 and Device B would respond with a message embedded in pacing pulse 136. Preferably, the embedded data 142 does not affect the effectiveness of therapy of the pacing pulse 130.

[0059] The signals for conducted communication are generally intended to have amplitudes that will not cause cardiac or skeletal muscle contraction, with the exception of the case in which the conducted communication is embedded in a stimulus signal, such as pacing pulse 130 with data 132 in FIG. 4. Typically, the patient should not be aware of the conducted communication signal. In FIG. 4, the amplitude, duration and/or frequency content of the data packet 134 would be selected to avoid stimulating muscle (skeletal or cardiac). Delivery of the data packet 134 during the QRS complex 132 could cause Device B to miss the signal or interpret it as part of the QRS complex 132. Therefore, as indicated at 140, the data packet 134 is intentionally delivered after the conclusion of the QRS complex for beat 132. Meanwhile, the data packet 134 must also terminate prior to delivery of the next pacing pulse 136.

[0060] While the illustration of FIG. 4 suggests avoidance of the QRS complex, some examples may not include such avoidance. For example, communication may be delivered using pulse widths which will allow receiving circuitry to distinguish the QRS complex from a conducted communication signal by the use of high pass filtering, since the QRS complex generally comprises signal frequencies below 40 Hertz. Some examples of optimization of communication relative to a biological signal such as the QRS complex are shown in U.S. Provisional Patent Application No. 62/134,752, titled COMMUNICATIONS IN A MEDICAL DEVICE SYSTEM WITH TEMPORAL OPTIMIZATION, filed on Mar. 18, 2015, the disclosure of which is incorporated herein by reference.

[0061] FIG. 5 illustrates a scenario in which multiple biological signals interact with and potentially impair communication. A signal representative of the impact of respiration is shown at 150, as well as an ECG signal at 152 and communication for Device A at 154 and Device B at 156. At 160 a combination of communication signals are shown for Device B with a response from Device A. These communications take place after a QRS complex on the ECG. However, a later communication from Device B at 162 is not acknowledged at 164 by Device A, possibly due to the interference of the ECG 152 having a QRS complex at 166. Later, at 170, Device B again tries to communicate, however, the respiration signal at 174 interferes. The respiration signal 174 may represent a temporary change in transthoracic impedance or a motion artifact as the patient's chest moves, for example.

[0062] Other factors may come into play as well. For example, referring to FIG. 1, if two electrodes are placed on the ends of the LCP 16 in an orientation that is orthogonal to the electric field of a conducted communication that is sent to the LCP, the LCP may not "see" the signal, as the sensing electrodes on the LCP would be at equipotential relative to the incident electric field. If so, there would be a handful of potential mitigations including repositioning the LCP, selecting a different pair of electrodes on the LCP (if available) for receiving the signal, and selecting a different

set of electrodes for sending the signal to the LCP from the SICD, for example. Thus, there are several factors that can affect the success of communication attempts.

[0063] FIG. 6 illustrates a flow diagram and graphic for an illustrative method. In the method of FIG. 6, a testing regimen is put into place to identify and analyze potential interference sources. In the example, a rate estimate is made at 200. For this example, the ECG is the interference source under test, and so the "rate" is the cardiac beat rate, which can be determined in several ways including, for example, determining the period at which cardiac cycles occur by identifying R-waves, QRS complexes or other known recurrent parts of the cardiac cycle.

[0064] Using the estimated rate from 200, a period is set at 202, in which the period is selected to exceed a biological cycle. Here, the period would be chosen as the inverse of the cardiac beat rate plus, optionally, an additional margin. Optionally, one of the devices involved in the test may then transmit the testing plan at 204 to the other device(s) in the test. For example, if the system involved includes an SICD, an LCP, and an external programmer, either the SICD or LCP may provide the rate to the external programmer (or, if equipped for the task, the external programmer may calculate a rate). Then the external programmer may communicate a testing plan to each of the implanted devices at 204, in which the period to be used would be sent, along with an instruction to perform a conducted communication test.

[0065] In another embodiment, the external programmer can be omitted, and the SICD may provide a plan to the LCP, or the LCP may provide a plan to the SICD. Alternatively, a plan may not need to be conveyed. As shown below, the test will involve delivering a relatively long-duration communication output; the receiving device may be equipped to identify the long-duration communication output as a test mode, and simply wait for the communication output to terminate. The communication of a plan 204 is not necessary but may be helpful for the receiving device of a test communication output to determine that it is not being subjected to an external noise, for example.

[0066] Next the test is performed as shown at 206. The test sequence is shown graphically, with the ECG shown at 220, communication outputs of Device A shown at 222, and communication output of Device B shown at 224. In the test, Device A provides a communication packet at 230, which is acknowledged and responded to by device B at 232. This exchange 230/232 may include the optional test plan.

[0067] Next, a long-duration communication output is generated by Device A, as shown at 234. As highlighted at 236, the period for the long-duration communication output 234 is selected to exceed the length of a cardiac cycle. Optionally, during the long-duration communication pulse output 234, a pre-specified pattern of data may be communicated (for example, all "1s", all "0s" or a repeating 01010101 sequence). Device B listens for the output 234 and assesses communication metrics which may include, for example, amplitude, relative signal strength indicator (RSSI), signal-to-noise ratio (SNR), slew, frame error or bit error rate (BER), or others. By monitoring over time, the test method can determine how the ECG affects these communication metrics.

[0068] In one embodiment, a mapping can be generated by having the ECG 120 captured by one of the devices (either implant or the external programmer, depending on which are available) synchronized to the long-duration communication

output **234**. Such a mapping could indicate, for example, if the SNR, RSSI, or BER change depending on the state of the ECG. For example, the mapping may indicate if the BER increases or RSSI decreases during the QRS complex of the ECG.

[0069] Following the test, results can be reported at **208**. For example, Device B may send a communication packet **238** to Device A containing data relating to the observed communication metrics. Such results can be exchanged between two implanted systems or may be sent to an external device (such as a programmer or smartphone) to enable configuration of system communication. A communication strategy may be formulated and redistributed among the devices in the system, if desired. Examples of strategy elements may include:

[0070] timing of communication relative to a biological marker such as a transthoracic impedance peak, QRS complex, R-wave, other cardiac signal, respiration signal, or received artifact such as a motion artifact

[0071] selection of or tiering of communication vectors if multiple vectors are available

[0072] communication retry strategies including timing or other changes to be made with retries

[0073] modifications to communication signal amplitude, data rate or other characteristic

[0074] strategies for handling urgent versus non-urgent communications with respect to any of the above Any of these elements may be integrated into a communication strategy for the system.

[0075] FIGS. 7 and 8 are diagrams illustrating communications pulses and test signals relative to biological signals. Referring first to FIG. 7, the represented signals include a signal representative of respiration **250**, the ECG **252**, Device A **254**, and Device B **256**. Optionally, Device A issues a communication at **260** requesting a test sequence, and Device B provides a response at **262** acknowledging, approving, and indicating a period to use in the communication. Device A then issues a long-duration communication signal at **264**, this time being of a duration sufficient to capture a full respiration cycle, L, plus some margin, delta. Device B observes the signal **264** and one or more metrics of the communication quality and may communicate such information in packet **266** either back to Device A or to an external programmer. A mapping of the received communication characteristics can be generated using the information captured by Device B, and referencing one or both of the Respiration signal **250** or ECG **252**.

[0076] FIG. 8 illustrates an example in which multiple communication configurations can be tested. ECG is shown at **280**, and communication behavior of Device A at **284** and Device B at **282**. Here, Device A sends a first packet at **286** to request and/or provide parameters for an upcoming test, and Device B provides acknowledgement and/or parameters at **288**. A first test is provided at **290**, spanning at least one cardiac cycle as illustrated by the ECG **280**. Device B acknowledges the end of the first test **290** with a response at **292**. This acknowledgement **292** may indicate a need for further testing, if desired. Device A then reconfigures itself by, for example, selecting a different communication vector, increasing or decreasing signal power or data rate, or adjusting a data format or frequency for communication. A second test occurs at **294**, again overlapping an entire cardiac cycle as shown in the ECG, and device B provides an acknowledgement and test data at **296**.

[0077] In an alternative, in the arrangement of FIG. 8, the communication **292** between tests by Device B may indicate a difficulty receiving the first test signal **290**, and instructions to reposition Device A or Device B may be provided. Once the repositioning is completed, then the second test signal **294** can be generated. Additional intervening data packets may be provided by one or both of Devices A, B, or an external programmer, to facilitate retest.

[0078] In another alternative, the first test signal **290** may be provided while a patient is assuming a first posture, for example, the patient may be supine, prone, seated or standing. The second test signal **294** may be provided with the patient in a different posture. In this manner, the possible impact on communication success of relative movement and/or reorientation of Device A and Device B due to postural changes can be tested.

[0079] The system may be configured to use a communication plan that adjusts a communication configuration to account for posture changes. To accommodate a postural plan for communication, one or more implanted devices may include an accelerometer, piezoelectric device, or other feature to allow identification of the patient's posture and to accommodate any modification of communication that would be taken in response. For example, a device may have an accelerometer allowing tracking of the patient's posture between at least first and second states. If testing shows that the first state is suited to a first communication configuration, while the second state is suited to a second communication configuration, the device may switch communication configurations when a detected change from the first state to the second state occurs.

[0080] FIGS. 9-10 are flow diagrams for illustrative methods. In FIG. 9, as shown at **300**, a first test is performed using a first communication vector, and a second test is performed at **302** using a second communication vector. A report is generated at **304**, and the communication vector for default use is selected at **306**.

[0081] FIG. 10 provides another example. Here, an implant procedure is begun at **320** for example, for an LCP. One or more communication vectors may be tested at **322** using for example an SICD, and the position/orientation of the device being implanted can then be adjusted as noted at **324**. For example, with an LCP, the position of the LCP on the cardiac wall may be adjusted, or the LCP may be rotated. As indicated at **326**, with the new orientation a retest may be performed.

[0082] For example, in an SICD/LCP combination system, the SICD may be implanted first. The LCP can be advanced to the right ventricle, but remain un-fixated, or fixated but not released, by the delivery catheter. A test mode can then be called for the SICD and LCP to check on communication signals between the SICD/LCP. The two implants may do all the work themselves, or an external programmer may be used to gather data from either or both. If desired, an external programmer may communicate with the LCP either by conducted communication or by virtue of continued coupling to the delivery catheter (that is, connected communication) may provide a feedback signal (audible or visual, for example) relating to the communication quality during the implant. The implanting physician may adjust the implant position, communication sensitivity or power level of the LCP prior to fixation or release to ensure good communication between the LCP and the SICD. The physician may also adjust settings of the SICD. The feedback

signal may be provided in real-time, if desired, that is, as measurement readings are generated by one of the implanted devices, those readings can be communicated to the external programmer and displayed to the user.

[0083] In one example, a first implant monitors conducted communication signals received from a second implant using a first pair of electrodes, and generates an output communication using a different, possibly orthogonal, pair of electrodes (for conducted communication) or an antenna or inductive element (for RF or inductive communication) for receipt and display by an external programmer as measurements are made. FIG. 11 illustrates an example.

[0084] In FIG. 11, the conducted communication of Device A is shown at 330, a first communication channel for device B is shown at 332 as B(1), and may in this example be conducted communication, a second communication channel for Device B is shown at 334 as B(2) and may represent any of connected, conducted, RF, optical, acoustic, or inductive communication, and the ECG is shown at 336. As with other examples, Device A and Device B optionally exchange messages 340, 342 relating to an impending long-duration test pulse 344 that is intended to span a biological cycle such as that on the ECG. During the test pulse 344, Device B issues a number of data packets 348 which may be intended for receipt by another implanted device, by an external programmer, or by Device A, which may include at least two communication channels as well.

[0085] In one example, Device B is an LCP having sufficient electrodes to have two spatially diverse (such as orthogonal) conducted communication channels, while Device A is an SICD having sufficient electrodes disposed on the torso of the patient to support at least two spatially diverse (such as orthogonal) conducted communication channels. In an alternative, Device A and Device B can communicate using one mode of communication on a first channel and a second mode of communication on a second channel. In another example, a higher power communication mode (RF, for example) is used during testing of a lower power communication mode (conducted communication).

[0086] FIGS. 12A-12E show programmer screens for an illustrative method. The test method can begin with the programmer screen in FIG. 12(A), instructing the user to press start to begin testing. The testing then takes place with a "wait" screen illustrated in FIG. 12(B); a status or progress bar may be provided as well. FIG. 12(C) illustrates a screen indicating that the communication testing was successful, with an exit button. FIG. 12(D) shows a screen indicating that the communication testing was unsuccessful or marginally successful and communication ability is limited. The user is presented the opportunity to adjust the system setup, which may include repositioning one or more devices/electrodes, or may include changing a setting in one or more devices either as directed by the user or by following an adjustment/retest protocol. If the user elects, the setup may be left as-is, with limited inter-device connectivity by selecting the Exit button. FIG. 12(E) shows a real-time feedback screen which may indicate to the user the status of the communication link during adjustment of device positioning. For example, if an LCP is being implanted, the signal strength of conducted communication with another implanted device can be displayed on the programmer screen while the implant is taking place. As an alternative,

audible tones or other indicator can be provided, in place of or in addition to a visible indication on the programmer screen.

[0087] FIG. 13(A) illustrates a testing setup for implanted systems with an external programmer. The external programmer is shown at 350 with a pair of surface electrodes 352, 354, and a telemetry wand 356. An SICD is shown at 360 with a lead extending to electrodes 362, 364, and 366, with the canister housing the SICD also being an electrode. An LCP is shown at 370, and in the detail view of FIG. 13(B), includes electrodes 372, 374, 376, 378. In the configuration shown, the LCP 370 may engage in conducted communication with the surface electrodes 352, 354 of the programmer 350, as well as with the housing and lead electrodes 362, 364 and 366 of the SICD 360.

[0088] Thus, in one example, the LCP could use electrodes 374, 378 as opposing poles for conducted communication with the surface electrodes 352, 354 of the programmer 350, while also using electrodes 372, 376 as opposing poles for conducted communication with electrode 364 and the housing of the SICD, to allow for real-time monitoring of communication qualities to the programmer 350 for display to a user. In another example, the LCP could generate a conducted communication output using electrodes 372, 376 for receipt by electrodes 362, 366 of the SICD 360, which in turn can provide real-time data on conducted communication via an antenna (not shown) for RF telemetry to the wand 356 and programmer 350 for display to a user. In yet another example, the LCP may receive conducted communication using electrodes 372, 376 from the housing and electrode 364 of the SICD, while sending data packets to the SICD using electrodes 374, 378 for receipt by electrodes 362, 366. Other configurations and combinations may also be used.

[0089] FIGS. 14-16 are flow diagrams for additional embodiments. In FIG. 14, the testing process begins with Device A telling device B that a test of conducted communication is going to occur at 400. Next, device A issues first and second communications to device B as indicated at 402. Device B receives the first and second communications as indicated at 404. Finally, Device B reports the results of the test to an external programmer, P, as indicated at 406, providing one or more of a preference between the first and second communication attempts and/or communication metrics such as signal strength, signal-to-noise ratio or bit error rate, for example. Optionally, P may provide a message to a user/physician to adjust positioning of one or more implanted devices, as shown at 408. Also, optionally, device A may again communicate one or more data packets to device B to provide real-time feedback to the physician, at 410. If desired, the entire method may be replaced by block 410 alone, in which case the real-time feedback may be provided for each communication test. Though not shown, the programmer P may also issue commands to device A to implement a specific configuration of conducted communication.

[0090] In FIG. 15, again, device A may indicate to device B that communication testing is to occur, as shown at 420. Next, device A issues first and second communication messages, as shown at 422. Finally, device B receives and analyzes the communications from A, and issues a report to Device A, as indicated at 424.

[0091] In FIG. 16, the initial message from Device A to Device B indicating that testing is to take place may be

omitted. Instead, the method begins with Device A communicating to Device B, as shown at 440. Next, device B provides an indication that a poor signal was received, as shown at 442. Device A may then reconfigure itself and perform a conducted communication test, as shown at 444. In response to the test, device B provides a report on the communication quality for the reconfigured device A, as shown at 446. If the reconfiguration resulted in better quality sufficient to meet the system needs, then the reconfiguration can be stored in Device A and used as a new default configuration. Otherwise, if the communication quality does not improve, Device B may set an error flag and communicate such an error to Device A, as indicated at 450, in addition to or as an alternative for performing a retest 452.

[0092] If desired, one or more therapy or other modes for either of Device A or Device B may be disabled in conjunction with the error flag at 450. For example, if Device A is an SICD, and device B is an LCP, and the SICD is set up to command antitachycardia pacing (ATP) by the LCP using conducted communication, the setting of the error flag at 450 may suspend the ability of the SICD to command ATP.

[0093] Following are a number of additional illustrative examples which should be viewed as providing additional examples and not as limitations on the invention.

[0094] A first non-limiting example is an implantable medical device comprising means for communicating by conducted communication with at least a second implantable medical device, in which the means for communicating may include the I/O circuitry 58 of FIG. 2 along with the electrodes 64, 66 and/or 72, as controlled by the processing circuitry 52 and/or powered by therapy circuitry 60. The first non-limiting example further includes means for setting the communication module into a continuing receive mode for analyzing a first signal received from the second implantable medical device and a second signal received from the second implantable medical device, where the means for setting may comprise the processing circuitry 52 using embedded instructions or an instruction set from memory 54 which is configured to perform in the manner described relative to testing Device B in FIG. 8 (receiving signals 290 and 294, for example), and/or the manner described relative to blocks 300 and 302 of FIG. 9. This first non-limiting example may further comprise means for analyzing the first signal and the second signal as received by the means for communicating which may include the I/O circuitry 58 of FIG. 2 using dedicated circuitry or operating in concert with the processing circuitry 52 of FIG. 2 (and memory 54) to generate analytics such as amplitude, relative signal strength, signal-to-noise ratio, slew, and frame or bit error rate; the means for analyzing may further include input circuitry for analyzing a biological signal including, for example, an ECG or EGM analyzer, skeletal or diaphragm muscle signal analyzer, an accelerometer, a pressure sensor, a microphone for observing sounds such as heart sounds, a blood analyte sensor, or a surrogate of a biological signal such as a thoracic impedance monitor, etc. Finally the first non-limiting embodiment may comprise means for generating an output communication indicating a result of the analysis of the first signal and the second signal, wherein the means for generating an output may comprise the processing circuitry 52 of FIG. 2 making use of one of conducted communication circuitry including the I/O circuitry 58 and electrodes 64, 66, and/or 72, or the communication circuitry 62 and antenna 74, which

may perform as shown in block 208 of FIG. 6, or block 304 of FIG. 9, or block 406 of FIG. 14, or block 424 of FIG. 15, and associated text.

[0095] A second non-limiting example takes the form of an implantable medical device comprising means for communicating by conducted communication with at least a second implantable medical device in which the means for communicating may include the I/O circuitry 58 of FIG. 2, as controlled by the processing circuitry 52 and/or powered by therapy circuitry 60 where the processing circuitry may use embedded instructions or instructions stored in memory 54. The second non-limiting example further includes at least first, second and third electrodes (such as electrodes 64, 66 and/or one or more of the electrodes at 72), configured for conducted communication with the second implantable medical device such that at least first and second conducted communication vectors are available for use by the communication means. The second non-limiting example further includes means for setting the means for communicating to a continuing transmit mode for using the first conducted communication vector to generate an output, and then using the second conducted communication vector to generate an output, the means for setting including at least the I/O circuitry 58 of FIG. 2, as controlled by the processing circuitry 52 and/or powered by therapy circuitry 60, where the processing circuitry may use embedded instructions or instructions stored in memory 54, which may perform as shown in FIG. 8 (with communications 290 and 294) or in accordance with blocks 300 and 302 of FIG. 9, or block 402 of FIG. 14, or block 422 of FIG. 15, as well as associated text. The second non-limiting example further includes means for determining, from information provided back to the implantable medical device, which, if any, of the first conducted communication vector and second conductive communication vector is to be used for delivering conducted communication messages to the second implantable medical device, which means may include the processing circuitry 52 and/or powered by therapy circuitry 60, where the processing circuitry may use embedded instructions or instructions stored in memory 54, which may perform as noted at block 304 of FIG. 9, or blocks 404/406 of FIG. 14, or block 424 of FIG. 15, as well as associated text. Finally the second non-limiting embodiment may include means for setting a default conducted communication vector for use by the means for communicating, the processing circuitry 52 and/or powered by therapy circuitry 60, where the processing circuitry may use embedded instructions or instructions stored in memory 54 and may perform the steps as noted by block 306 of FIG. 9 and associated text.

[0096] Those skilled in the art will recognize that the present disclosure may be manifested in a variety of forms other than the specific examples described and contemplated herein. For instance, as described herein, various examples include one or more modules described as performing various functions. However, other examples may include additional modules that split the described functions up over more modules than that described herein. Additionally, other examples may consolidate the described functions into fewer modules. Accordingly, departure in form and detail may be made without departing from the scope and spirit of the present disclosure as described in the appended claims.

What is claimed is:

1. A method of configuring communication between implantable medical devices comprising:

in a first medical device having a plurality of electrodes configured for outputting a conducted signal, generating a first conducted signal using a selected pair of electrodes;

in a second medical device, receiving and analyzing the first conducted signal;

in the second medical device, communicating a second signal related to an outcome of the analysis of the first conducted signal while the first conducted signal is being received.

2. A method as in claim 1 further comprising receiving the second signal in the first medical device while the first conducted signal is still being generated.

3. The method of claim 2 wherein the second signal is a conducted signal received by the first medical device using a different pair of electrodes than the pair used for generating the first conducted signal.

4. The method of claim 1 further comprising receiving the second signal with an external device configured for communication with at least one of the first medical device and the second medical device.

5. The method of claim 4 wherein:

the second medical device analyzes the first conducted signal and calculates communication metrics of the first conducted signal as received by the second medical device;

the second signal encodes data related to the communication metrics of the first conducted signal as received by the second medical device; and

the external device is configured to provide real time feedback to a user related to the communication metrics.

6. The method of claim 5 wherein the external device provides real time feedback in the form of a message indicating adjustment of positioning of at least one of the first or second medical devices is desired.

7. The method of claim 1 wherein the first and second medical devices are each leadless cardiac pacemakers.

8. The method of claim 1 wherein the first medical device is a leadless cardiac pacemaker, and the second medical device is an implantable cardioverter defibrillator.

9. A method of configuring communication between implantable medical devices during an implantation procedure of a first medical device in a patient in whom a second medical device is already implanted, the method comprising:

during an implantation procedure for the first medical device, testing communication between the first medical device and the second medical device;

determining that communication is suboptimal; and

in response to determining that communication is suboptimal, adjusting an orientation of the first medical device.

10. The method of claim 9 wherein at least one of the first medical device and the second medical device is configured for communication with an external programmer, the method further comprising obtaining a feedback signal from the external programmer which indicates in real time a quality of a communication link between the first medical device and the second medical device.

11. The method of claim 9 wherein the first medical device is a leadless cardiac pacemaker and the second medical device is an implantable cardioverter defibrillator.

12. The method of claim 9 wherein the first medical device is a leadless cardiac pacemaker (LCP) which is implanted by advancing an implantation catheter to a desired location and then securing the LCP at the desired location and decoupling the implantation catheter from the LCP, wherein the step of testing communication is performed while the LCP is coupled to the implantation catheter and before the LCP is secured at the desired location.

13. The method of claim 9 wherein the step of testing communication between the first medical device and the second medical device comprises:

the first medical device generating a first conducted signal using a selected pair of electrodes;

the second medical device receiving the first conducted signal;

the second medical device calculating communication metrics based on the first conducted signal; and

the second medical device communicating the calculated communication metrics to an external programmer.

14. The method of claim 9 wherein the step of testing communication between the first medical device and the second medical device comprises:

generating a first conducted signal from the first medical device to the second medical device comprising an output pattern for a selected period; and

receiving the conducted signal by the second medical device and calculating a first communication metric of the first conducted signal as received;

wherein the selected period exceeds an expected or detected length of a recurring biological cycle.

15. The method of claim 9 wherein the first and second medical devices are each leadless cardiac pacemakers.

16. A method of operation in an implantable medical device system comprising an external programmer and first implantable medical device and a second implantable medical device, the method being configured for communication quality monitoring during a procedure to implant the second medical device while the first medical device is already implanted, the method comprising:

the first medical device generating a communication test signal prior to completion of placement of the second medical device during the procedure to implant the second medical device;

the second medical device receiving and analyzing the communication test signal from the first medical device;

the second medical device generating an output indicating a quality of the communication test signal as received;

the programmer providing an indication to a physician performing the implantation procedure related to the quality of the communication test signal as received by the second medical device.

17. The method of claim 16 wherein the step of the second medical device generating an output indicating a quality of the communication test signal comprises the second medical device communicating to the programmer in real time, such that the step of the programmer providing an indication is performed in real time.

18. The method of claim 16 wherein the step of the second medical device generating an output indicating a quality of the communication test signal comprises the second medical

device communicating back to the first medical device and the first medical device communicating to the programmer to facilitate the programmer providing the indication to the physician.

19. The method of claim **16** wherein the first and second medical devices are each leadless cardiac pacemakers.

20. The method of claim **16** wherein the first medical device is a subcutaneous implantable cardioverter defibrillator and the second medical device is a leadless cardiac pacemaker.

* * * * *

专利名称(译)	具有链路质量评估的医疗设备系统中的通信		
公开(公告)号	US20190143130A1	公开(公告)日	2019-05-16
申请号	US16/247304	申请日	2019-01-14
[标]申请(专利权)人(译)	心脏起搏器股份公司		
申请(专利权)人(译)	心脏起搏器, INC.		
当前申请(专利权)人(译)	心脏起搏器, INC.		
[标]发明人	MAILE KEITH R KOOP BRENDAN E SCHMIDT BRIAN L KANE MICHAEL J LUDWIG JACOB M STAHMANN JEFFREY E JUFFER LANCE E		
发明人	MAILE, KEITH R. KOOP, BRENDAN E. SCHMIDT, BRIAN L. KANE, MICHAEL J. LUDWIG, JACOB M. STAHMANN, JEFFREY E. JUFFER, LANCE E.		
IPC分类号	A61N1/372 A61B5/024 A61N1/362 A61B5/00 A61N1/375 A61N1/39 H04B13/00 A61B5/02 A61B5/08 A61B5/11		
CPC分类号	A61N1/37288 A61B5/024 A61N1/362 A61B5/0024 A61B5/7221 A61B5/6869 A61N1/37252 A61B5/0028 A61N1/3756 A61N1/3962 H04B13/005 A61B5/0002 A61B5/02 A61B5/08 A61B5/11 A61N1/37217 A61N1/3727 A61N1/37205 A61N1/37247		
优先权	62/134726 2015-03-18 US		
外部链接	Espacenet USPTO		

摘要(译)

用于测试和配置可植入医疗设备系统的方法和设备。第一医疗设备和第二医疗设备使用测试信号彼此通信，该测试信号被配置为提供与通信信号的质量有关的数据，以便于优化通信方法。在手术期间可以执行一些方法以植入一个医疗装置以确保足够的通信可用性。

