



US 20190021658A1

(19) **United States**

(12) **Patent Application Publication**
Li

(10) **Pub. No.: US 2019/0021658 A1**

(43) **Pub. Date: Jan. 24, 2019**

(54) **DUAL PURPOSE WEARABLE PATCH FOR MEASUREMENT AND TREATMENT**

(71) Applicant: **VivaLnk, Inc.**, Campbell, CA (US)

(72) Inventor: **Jiang Li**, Cupertino, CA (US)

(21) Appl. No.: **16/141,794**

(22) Filed: **Sep. 25, 2018**

Related U.S. Application Data

(63) Continuation of application No. 15/457,532, filed on Mar. 13, 2017, now Pat. No. 10,111,618.

Publication Classification

(51) **Int. Cl.**

<i>A61B 5/00</i>	(2006.01)
<i>A61N 1/36</i>	(2006.01)
<i>A61N 1/04</i>	(2006.01)
<i>A61B 5/11</i>	(2006.01)
<i>A61B 5/024</i>	(2006.01)
<i>A61B 5/021</i>	(2006.01)
<i>A61B 5/01</i>	(2006.01)

(52) **U.S. Cl.**

CPC *A61B 5/4836* (2013.01); *A61N 1/36014* (2013.01); *A61N 1/0492* (2013.01); *A61B 5/6815* (2013.01); *A61B 5/6832* (2013.01); *A61B 2562/164* (2013.01); *A61B 5/11* (2013.01); *A61B 5/02438* (2013.01); *A61B 5/021* (2013.01); *A61B 5/01* (2013.01); *A61B 5/0008* (2013.01)

(57) **ABSTRACT**

A dual purpose wearable patch includes a stretchable and permeable substrate, a sensing unit mounted in the stretchable and permeable substrate, wherein the sensing unit can conduct a measurement of a user to produce a measurement signal, one or more electrodes respectively attached to the stretchable and permeable substrate, a circuit substrate on the stretchable and permeable substrate, wherein the circuit substrate includes a circuit electrically connected with the one or more electrodes and the sensing unit, and a semiconductor chip mounted on the circuit substrate and in connection with the circuit. The semiconductor chip can receive the measurement signal from the sensing unit and can produce a treatment control signal to control the one or more electrodes to apply a voltage across the user's body.

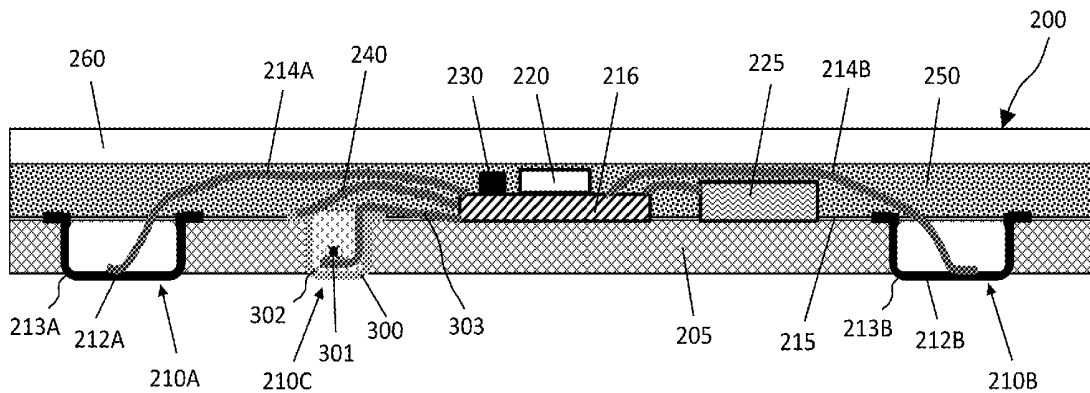

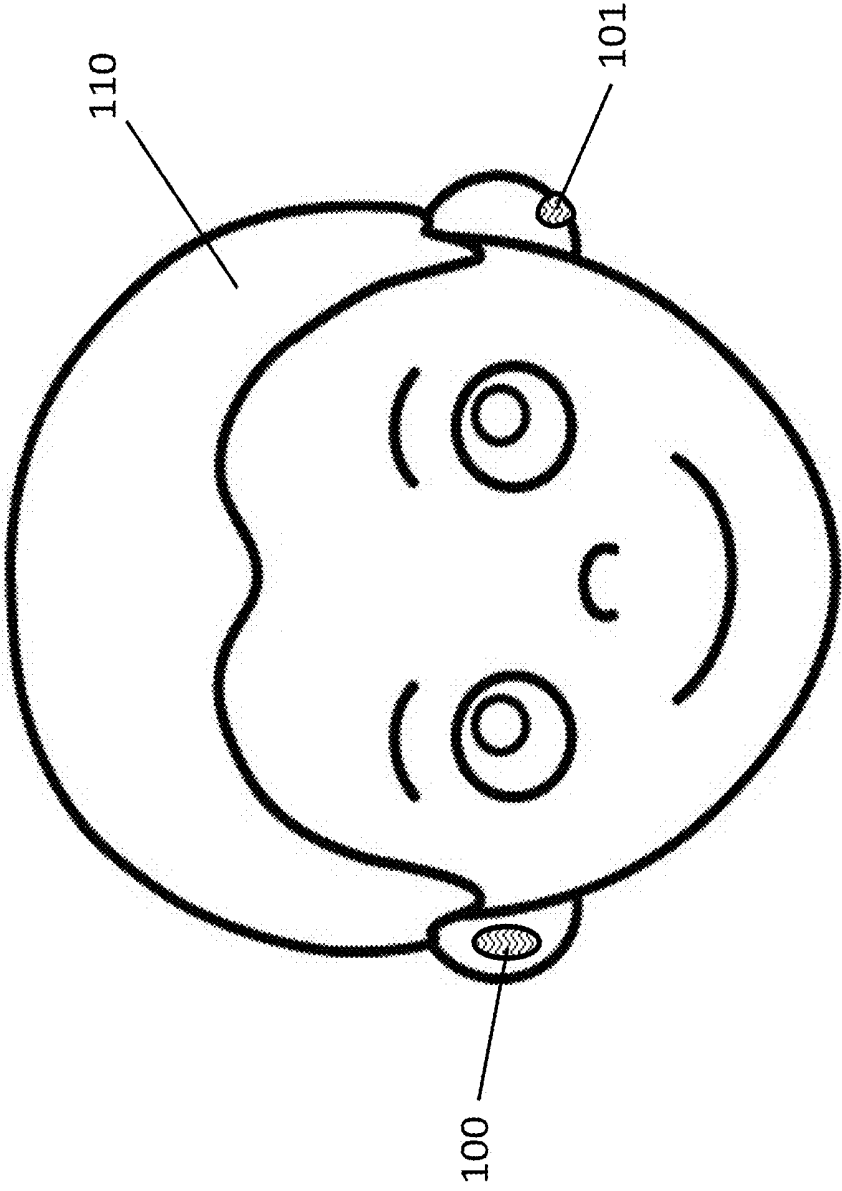

Figure 1

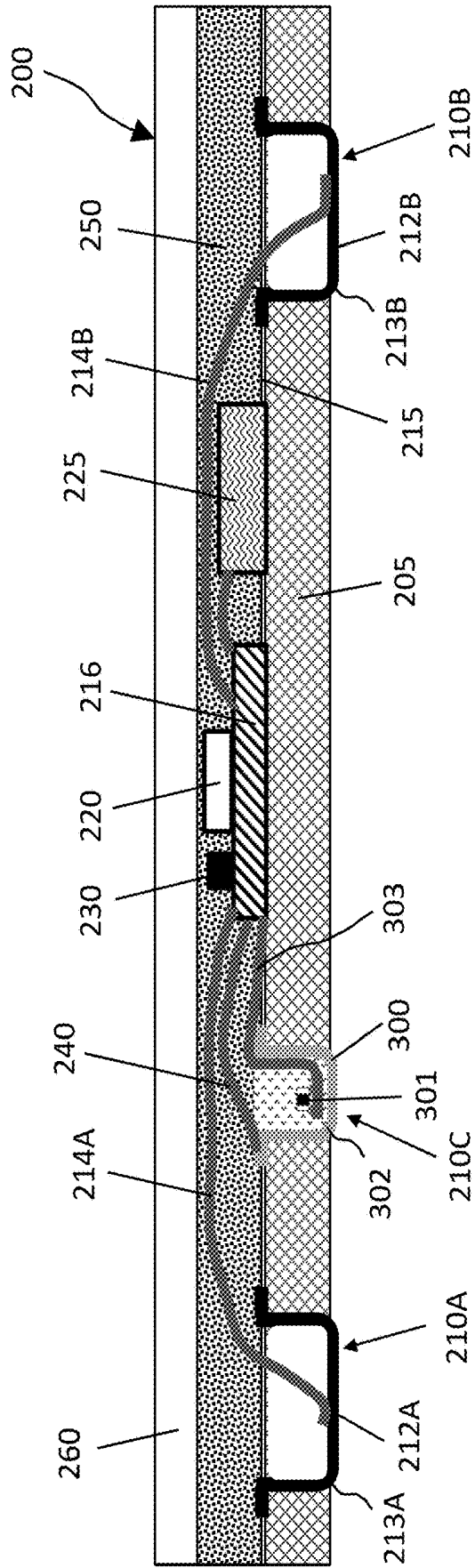

Figure 2

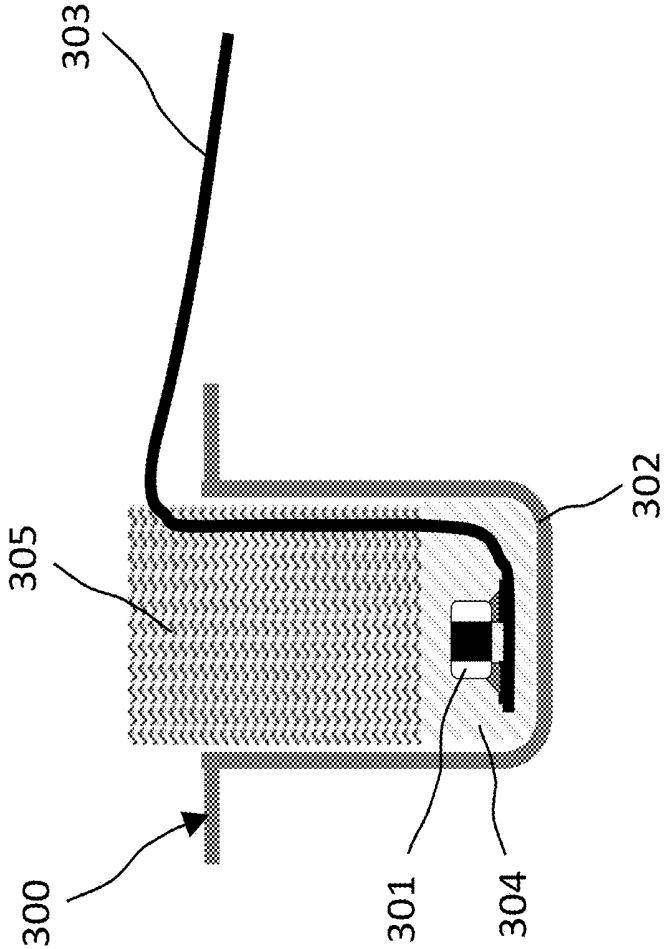

Figure 3

DUAL PURPOSE WEARABLE PATCH FOR MEASUREMENT AND TREATMENT

BACKGROUND OF THE INVENTION

[0001] The present application relates to wearable electronic devices, and in particular, to wearable patches that can attach to human skin.

[0002] Electronic patches can be used for tracking objects and for performing functions such as producing sound, light or vibrations, and so on. As applications and human needs become more sophisticated and complex, electronic patches are required to perform a rapidly increasing number of tasks. Electronic patches are often required to be conformal to curved surfaces, which in the case of human body, can vary overtime.

[0003] Electronic patches can communicate with smart phones and other devices using WiFi, Bluetooth, Near Field Communication (NFC), and other wireless technologies. NFC is a wireless communication standard that enables two devices to quickly establish communication within a short range around radio frequency of 13.56 MHz. NFC is more secure than other wireless technologies such as Bluetooth and Wi-Fi because NFC requires two devices in close proximity (e.g. less than 10 cm). NFC can also lower cost comparing to other wireless technologies by allowing one of the two devices to be passive (a passive NFC tag).

[0004] Bluetooth is another wireless communication standard for exchanging data over relatively longer distances (in tens of meters). It employs short wavelength UHF radio waves from 2.4 to 2.485 GHz from fixed or mobile devices. Bluetooth devices have evolved to meet the increasing demand for low-power solutions that is required for wearable electronics. Benefited from relatively longer reading distance and active communication, Bluetooth technologies allow wearable patches to continuously monitoring vital information without human interference, which is an advantage over NFC in many applications.

[0005] Wearable patch (or tag) is an electronic patch to be worn by a user. A wearable patch is required to stay on user's skin and operate for an extended period of time from hours to months. A wearable patch can contain a micro-electronic system that can be accessed using NFC, Bluetooth, WiFi, or other wireless technologies. A wearable patch can be integrated with different sensors for measurements such as vital signs monitoring.

[0006] Traditionally, treatments can be conducted on patients using probes wire connected with heavy immobile equipment. For example, Cranial Electrotherapy Stimulation (CES) utilizes extremely small levels of electrical stimulation across the head of a patient for therapeutic treatment of anxiety, depression, insomnia and chronic pain.

[0007] There is therefore a need for convenient measurement of a patient's vital signs and other signals and treatment of the patient's symptoms.

SUMMARY OF THE INVENTION

[0008] The presently disclosure discloses a dual-purpose wearable device that can conveniently measure a patient's vital signs and other signals and treat the patient's symptoms. The disclosed wearable patch is easy and comfortable to wear by patients and do not require wire connections to heavy equipment.

[0009] Moreover, measurements and treatments can be conducted by the disclosed dual-purpose wearable patch while a patient fulfills his or her normal daily activities. Thus treatments can be timely and dynamically applied which such needs arise according to measurements of vital body signals and other signals.

[0010] Furthermore, effects of treatments can be immediately monitored by the dual-purpose wearable patch after it applies treatment.

[0011] In one general aspect, the present invention relates to a dual purpose wearable patch that includes a stretchable and permeable substrate; a sensing unit mounted in the stretchable and permeable substrate, wherein the sensing unit is configured to conduct a measurement of a user to produce a measurement signal; one or more electrodes respectively attached to the stretchable and permeable substrate; a circuit substrate on the stretchable and permeable substrate, wherein the circuit substrate comprises a circuit electrically connected with the one or more electrodes and the sensing unit; and a semiconductor chip mounted on the circuit substrate and in connection with the circuit, wherein the semiconductor chip is configured to receive the measurement signal from the sensing unit, wherein the semiconductor chip can produce a treatment control signal to control the one or more electrodes to apply a voltage across the user's body.

[0012] Implementations of the system may include one or more of the following. The semiconductor chip can produce a treatment control signal to control the one or more electrodes to apply a voltage across the user's body in response to a measurement signal. The dual-purpose wearable patch can further include a battery configured to supply power to the circuit and the semiconductor chip. The semiconductor chip can switch the circuit, the one or more electrodes, and the sensing unit into or off from a measurement mode and a treatment mode. The one or more electrodes can include a second electrode and a third electrode configured to apply a voltage across the user's body. The sensing unit can include a temperature sensor configured to measure the user's skin temperature, wherein the measurement signal comprises temperature data. The sensing unit can further include a thermally conductive cup having a bottom portion mounted in a first opening in the stretchable and permeable substrate, wherein the temperature sensor is positioned inside and is in thermal conduction cup with the conductive cup. The sensing unit can include a thermally conductive adhesive that fixes the temperature sensor to an inner surface of the conductive cup, and a thermally insulating material in a top portion of the conductive cup. The sensing unit can include an accelerometer configured to measure movement of the user. The sensing unit can include a pressure sensor or a force sensor configured to measure blood pressure or pulse of the user. The semiconductor chip can control a type, a frequency, or a duration of a measurement of the user by the sensing unit based on the voltage applied across the user's body. The dual purpose wearable patch can further include an antenna mounted on the circuit substrate and in electric connection with the semiconductor chip, wherein the semiconductor chip is configured to produce electric signals to enable the antenna to wirelessly exchange measurement data based on the measurement signal with an external device, wherein the semiconductor chip can produce electric signals to enable the antenna to wirelessly exchange treatment data with an external device, wherein the treatment control signal

is at least in part based on the treatment data. At least one of the one or more electrodes can include an electrically conductive cup that is electrically connected to the control circuit in the circuit substrate, wherein the stretchable and permeable substrate comprises a second opening in which the electrically conductive cup is mounted. The electrically conductive cup can be electrically connected with the circuit. The dual-purpose wearable patch can further include an adhesive layer between the stretchable and permeable substrate and the circuit substrate. The dual-purpose wearable patch can further include an elastic layer formed on the stretchable and permeable substrate, the circuit substrate, and the sensing unit. The sensing unit includes an accelerometer can measure the user's movement, wherein the measurement signal comprises movement data. The sensing unit can include a pressure sensor or a force sensor configured to measure the user's blood pressure and/or the user's pulse, wherein the measurement signal comprises pulse data and blood pressure data.

[0013] These and other aspects, their implementations and other features are described in detail in the drawings, the description and the claims.

BRIEF DESCRIPTION OF THE DRAWINGS

[0014] FIG. 1 illustrates dual-purpose wearable patches attached to a user's skin.

[0015] FIG. 2 is a cross-sectional view of an exemplified dual-purpose wearable patch for both measurement and treatment in accordance with some embodiments of the present invention.

[0016] FIG. 3 is a detailed cross-sectional view of an exemplified sensing unit in the dual-purpose wearable patch of FIG. 2.

DETAILED DESCRIPTION OF THE INVENTION

[0017] Referring to FIG. 1, one or more dual-purpose wearable patches 100, 101 are attached to the skin of a user 110 for measuring body vital signs. The dual-purpose wearable patch 100 can be placed on the ears, the forehead, the hands, the shoulder, the waist, the leg, or the foot, under the armpit, around the wrist, on or around the arm, or other parts of a user's body. In the present disclosure, the term "wearable patch" can also be referred to as "wearable sticker", "wearable tag", or "wearable band", etc.

[0018] As discussed in more detail below, dual-purpose wearable patches 100, 101 can operate individually, or in a group to provide certain desired treatment or measurement. For example, the purpose wearable patch 101 can wrap around a user's ear for applying an electric field through certain location of the ear. Similar, the disclosed purpose wearable patch can wrap around a user's wrist for providing treatment and measurement. Moreover, the dual-purpose wearable patches 100, 101 can be attached to different parts of a user's body such as on the two ears or the two temples of the user 100, which allows a low electric voltage signal to be applied across the user's head.

[0019] In accordance to the present invention, the disclosed dual-purpose wearable patch includes a treatment portion and a measurement portion. The measurement portion can measure vital signs, motion track, skin temperature,

and ECG signals. The treatment portion can apply electrical signals, heat, and sometimes force or pressure to user's body.

[0020] In some embodiments, referring to FIGS. 2 and 3, an exemplified dual-purpose wearable patch 200 includes a stretchable and permeable substrate 205 that include openings 210A, 210B, 210C. The stretchable and permeable substrate 205 can be made of soft foam materials such as EVA, PE, CR, PORON, EPD, SCF or fabric textile, to provide stretchability and breathability. The measurement portion of the disclosed dual-purpose wearable patch 200 includes a sensing unit 300 mounted in the opening 210C. The treatment portion of the disclosed dual-purpose wearable patch 200 includes two electrodes 212A, 212B, respectively comprising electrically conductive cups 213A, 213B, are mounted in the openings 210A, 210B. A circuit substrate 216 and a battery 225 are bonded to the stretchable and permeable substrate 205 by an adhesive layer 215 pre-laminated on the stretchable and permeable substrate 205. A semiconductor chip 220 and an antenna 230 are mounted on the circuit substrate 216. The circuit substrate 216 includes an electric circuit therein, which can for example be implemented with a printed circuit board.

[0021] The thermal conductive cup 302 in the sensing unit 300 is electrically connected with the circuit substrate 216 by a conductive line 240, which in turn establishes electrical communication between the thermal conductive cup 302 and the semiconductor chip 220.

[0022] An elastic layer 250 is also bonded to the stretchable and permeable substrate 205 by the adhesive layer 215 to the stretchable and permeable substrate 205. The elastic layer 250 is also formed on the circuit substrate 216, the sensing unit 300, and the electrodes 212A, 212B. The elastic layer 250 can be formed by soft stretchable and permeable foam materials such as EVA, PE, CR, PORON, EPD, SCF, or fabric textile. A thin film 260 is formed on the elastic layer 250 for protection and cosmetic purposes.

[0023] In usage, an adhesive material formed on the lower surface of the stretchable and permeable substrate 205 is attached the user's skin, so that the bottom of the thermal conductive cup 302 is in tight contact with a user's skin to accurately measure temperature, electrical, or pressure signals from the user's skin, or apply electrical, thermal, or mechanical signals to the user's skin. The semiconductor chip 220 receives an electric signal from the temperature sensor 301 in response to a temperature measurement of the user's skin.

The Treatment Portion

[0024] In some embodiments, the electrically conductive cups 213A, 213B in the electrodes 212A, 212B are respectively electrically connected to the electric circuit in the circuit substrate 216 by conductive lines 214A, 214B (e.g. flexible ribbons embedded with conductive circuits). In accordance with the present application, the electrodes 212A, 212B can also be implemented in other configurations such as conductive pins, conductive pads, conductive buttons, or conductive strips. The semiconductor chip 220 can produce treatment electric signals, which can be amplified by an amplifier (not shown in FIG. 2) with power supplied by the battery 225, which is sent to the electrodes 212A, 212B via the conductive lines 214A, 214B.

[0025] In some embodiments, the electric voltage (typically in low amplitude) generated across the electrodes

212A, 212B is applied to the user's skin for therapeutic treatment. For example, such Cranial Electrotherapy Stimulation treatment can be applied across the electrode in one disclosed dual purpose wearable patch across a user's ear lobe (e.g. **101** in FIG. 1) or across a user's wrist. In another example, electrical voltage signals can be applied across electrodes in two disclosed dual-purpose wearable patches (e.g. **100, 101** in FIG. 1). In this case, a thin conductive wire behind the user's neck can be tethered to the two dual-purpose wearable patches to provide proper ground for the voltage signals.

[0026] The semiconductor chip **220** can communicate with an external device such as a mobile phone or a computer via the antenna **230** in wireless signals. For example, the semiconductor chip **220** can receive a treatment plan from the external device. The wireless signal can be based on using WiFi, Bluetooth, Near Field Communication (NFC), and other wireless standards. The semiconductor chip **220** can generate the treatment electric signals at durations, intervals, and amplitudes as defined in the treatment plan.

[0027] When the dual-purpose wearable patch **200** is worn by a user, the antenna **230** is separated from the user's skin by the circuit substrate **216** and the stretchable and permeable substrate **205**, which minimizes the impact of the user's body on the transmissions of wireless signals by the antenna **230**.

Dynamic Treatment

[0028] In some embodiments, the semiconductor chip **220** can generate the treatment electric signals at durations, intervals, and amplitudes based on the measurement data obtained from the sensing unit **300**, as described below. For example, the electrotherapy stimulation treatment can be adjusted based on the user's skin temperature, heartbeats, and blood pressure measured by the sensing unit **300**. User's bio vital signals may indicate user's stress levels, which can be treated by appropriate waveforms of electrical signals.

The Measurement Portion

[0029] In some embodiments, in the measurement portion of the disclosed dual-purpose wearable patch **200**, the sensing unit **300** includes a temperature sensor **301** in a thermal conductive cup **302**, which has its bottom portion mounted into the large opening **210C** and fixed to the stretchable and permeable substrate **205** by an adhesive. The temperature sensor **301** is electrically connected to the electric circuit in the circuit substrate **216** by a flexible conductive ribbon **303**. Referring to FIG. 3, the bottom portion of the thermal conductive cup **302** protrudes out of the lower surface of the stretchable and permeable substrate **205**. The lips of the thermal conductive cup **302** near its top portion are fixedly attached or bonded to bonding pads (not shown) on the stretchable and permeable substrate **205** by soldering or with an adhesive. The thermal conductive cup **302** is both thermally and electrically conductive. The thermal conductive cup **302** can be made of a thermally conductive metallic or alloy material such as copper, stainless steel, ceramic or carbide composite materials.

[0030] The temperature sensor **301** is attached to an inner surface near the bottom of the thermal conductive cup **302**. The temperature sensor **301** can be implemented, for example, by a thermistor, a Resistor Temperature Detector,

or a Thermocouple. The temperature sensor **301** is in thermal conduction with the thermal conductive cup **302**. When an outer surface of the bottom portion of the thermal conductive cup **302** is in contact with a user's skin, the thermal conductive cup **302** thus effectively transfers heat from a user's skin to the temperature sensor **301**. A flexible conductive ribbon **303** is connected to the temperature sensor **301** in the thermal conductive cup **302** and to the electric circuit in the stretchable and permeable substrate **205**.

[0031] The temperature sensor **301** can send an electric signal to the semiconductor chip **220** via the electric circuit in response to a measured temperature. The semiconductor chip **220** processes the electric signal and outputs another electrical signal which enables the antenna **230** to transmit a wireless signal carrying the measurement data to another external device such as a mobile phone or a computer (its wireless signals, as described below, can be boosted by a charging and wireless boosting station). The wireless signal can be based on using WiFi, Bluetooth, Near Field Communication (NFC), and other wireless standards. The battery **225** powers the semiconductor chip **220**, the antenna **230**, the first and the second electric circuits, and possibly the temperature sensor **301**.

[0032] The temperature sensor **301** can be fixed to an inner surface at the bottom of the thermal conductive cup **302** by a thermally conductive adhesive **304**, which allows effective heat transfer from the bottom of the thermal conductive cup **302** to the temperature sensor **301**. Examples of the thermally conductive adhesive **304** can include electrically insulative thermally-conductive epoxies and polymers. A thermally insulating material **305** filling the top portion of the thermal conductive cup **302** fixes the thermally-conductive adhesive **304** at the bottom of the thermal conductive cup **302** and reduces heat loss from the temperature sensor **301** to the elastic layer (described below) or the environment. The flexible conductive ribbon **303** can be bent and laid out along the wall of the thermal conductive cup **302**.

[0033] Further details of the sensing unit are disclosed in the commonly assigned co-pending U.S. patent application Ser. No. 15/224,121 "Wearable thermometer patch for accurate measurement of human skin temperature", filed Jul. 29, 2016, the disclosure of which is incorporated herein by reference.

[0034] In some embodiments, the sensing unit **300** includes an accelerometer that can measure acceleration and movement of the user. In some embodiments, the sensing unit **300** includes a pressure sensor or a force sensor that can measure the user's pulses or blood pressure during or outside treatments.

[0035] In some embodiments, the sensing unit **300** includes one or more electrodes for measuring ECG signals. The electrode can for example be structured in an electrically conductive cup similar to the thermal conductive cup **302** described above. The ECG signal (voltage) can be measured across two of the electrodes or across one of the electrodes and one of the electrodes **212A, 212B** (used as ground). In particular, the ECG signals can be measured when the electrotherapy stimulation treatment is not conducted.

[0036] In some embodiments, the sensing unit **300** can include multiple sensors for temperature, movement, blood pressure, and pulse measurements.

Dynamic Measurement

[0037] In some embodiments, the semiconductor chip **220** can control the type(s) and frequencies of the measurement (s) by the sensing unit **300** in response to the types of treatment applied. For example, based on the durations, intervals, and amplitudes of the treatment electric signals, the frequencies, the durations and the type(s) of the measurement(s) can be varied to more accurately and more timely monitor the user's health conditions.

Mode Switching

[0038] The semiconductor chip **220** can control the circuit to switch the sensing unit **300** and the electrodes **210A**, **210B** into or off from a measurement mode, or into or off from a treatment mode. The mode switching can be specified in the treatment plan received from an external device, or dynamically adjusted according to the user's vital signals and responsiveness to treatment.

Personalized Medicine

[0039] Since the disclosed dual-purpose wearable patch is worn by an individual patient, the disclosed dual-purpose patch is ideal for personalized medical treatment. Each treatment plan download into the disclosed dual-purpose wearable patch can be individualized according to the patient's needs.

[0040] Moreover, the disclosed dual-purpose wearable patch can significantly enhance the effectiveness of individualized treatments for patients. In particular, treatments can be dynamically adjusted according to the current condition of the user as indicated by the bio vital signals currently measured from the user.

[0041] Other details about wearable patches capable of performing measurement and charging functions are disclosed in commonly assigned U.S. patent application Ser. No. 15/423,585, titled "A wearable patch comprising three electrodes for measurement and charging", filed Feb. 3, 2017, commonly assigned U.S. patent application Ser. No. 15/406,380, titled "A wearable thermometer patch for correct measurement of human skin temperature", filed Jan. 13, 2017, and commonly assigned U.S. patent application Ser. No. 15/414,549, titled "A wearable thermometer patch for measuring temperature and electrical signals", filed Jan. 24, 2017. The disclosures in the above applications are incorporated herein by reference.

[0042] The disclosed dual-purpose wearable patch is stretchable, compliant, durable, and comfortable to wear by users. The disclosed wearable thermometer patch includes a flexible substrate covered and protected by an elastic layer that increases the flexibility and stretchability.

[0043] Another advantage of the disclosed dual-purpose wearable patch is that it can significantly increase wireless communication range by placing the antenna on the upper surface of the circuit substrate. The thickness of the substrate as well as the height of the thermally conductive cup can be selected to allow enough distance between the antenna and the user's skin to minimize interference of user's body to the wireless transmission signals.

[0044] While this document contains many specifics, these should not be construed as limitations on the scope of an invention that is claimed or of what may be claimed, but rather as descriptions of features specific to particular embodiments. Certain features that are described in this

document in the context of separate embodiments can also be implemented in combination in a single embodiment. Conversely, various features that are described in the context of a single embodiment can also be implemented in multiple embodiments separately or in any suitable sub-combination. Moreover, although features may be described above as acting in certain combinations and even initially claimed as such, one or more features from a claimed combination can in some cases be excised from the combination, and the claimed combination may be directed to a sub-combination or a variation of a sub-combination.

[0045] Only a few examples and implementations are described. Other implementations, variations, modifications and enhancements to the described examples and implementations may be made without deviating from the spirit of the present invention.

What is claimed is:

1. A wearable patch, comprising:

a stretchable substrate;

two electrodes respectively attached to the stretchable substrate, wherein the two electrodes are configured to be in electrical contact with the user's skin and to apply a voltage across the user's body, wherein at least one of the two electrodes includes an upper portion and a lower portion, wherein the lower portion is configured to be in electrical contact with the user's skin;

a circuit substrate on the stretchable substrate, wherein the circuit substrate comprises a circuit electrically connected with the two electrodes; and

a semiconductor chip mounted on the circuit substrate and in connection with the circuit, wherein the semiconductor chip is configured to produce a treatment control signal to control the two electrodes to apply a voltage across the user's body.

2. The wearable patch of claim 1, wherein at least one of the two electrodes comprises an electrically conductive cup electrically connected with the circuit, wherein the stretchable substrate comprises a first opening in which the electrically conductive cup is mounted.

3. The wearable patch of claim 2, wherein the electrically conductive cup comprises a bottom portion configured to be in contact with the user's skin.

4. The wearable patch of claim 1, wherein the semiconductor chip is configured to produce a treatment control signal to control the two electrodes to apply a voltage across the user's body in response to a measurement signal.

5. The wearable patch of claim 1, further comprising:

an antenna mounted on the circuit substrate and in electric connection with the semiconductor chip, wherein the semiconductor chip is configured to produce electric signals to enable the antenna to wirelessly exchange treatment data with an external device, wherein the treatment control signal is at least in part based on the treatment data.

6. The wearable patch of claim 1, further comprising:

a sensing unit mounted in the stretchable substrate and electrically connected with the circuit, wherein the sensing unit is configured to conduct a measurement of a user to produce a measurement signal, wherein the semiconductor chip is configured to receive the measurement signal from the sensing unit,

7. The wearable patch of claim 6, wherein the semiconductor chip is configured to produce a treatment control

signal to control the two electrodes to apply a voltage across the user's body in conjunction with the measurement conducted by the sensing unit.

8. The wearable patch of claim 6, wherein the sensing unit includes a bottom portion adapted to be in direct contact with a user's skin

9. The wearable patch of claim 6, wherein the sensing unit comprises a temperature sensor in thermal contact with the bottom portion to conduct the measurement of a user to produce the measurement signal.

10. The wearable patch of claim 9, wherein the sensing unit further includes a thermally conductive cup having the bottom portion mounted in a second opening in the stretchable substrate, wherein the temperature sensor is positioned inside and is in thermal conduction cup with the conductive cup, wherein the bottom portion of the thermally conductive cup is configured to be in contact with the user's skin.

11. The wearable patch of claim 10, wherein the sensing unit comprises:

a thermally-conductive adhesive that fixes the temperature sensor to an inner surface of the conductive cup; and

a thermally insulating material in a top portion of the conductive cup.

12. The wearable patch of claim 9, wherein the temperature sensor is configured to measure the user's skin temperature, wherein the measurement signal comprises temperature data.

13. The wearable patch of claim 6, wherein the sensing unit includes an accelerometer configured to measure the user's movement, wherein the measurement signal comprises movement data.

14. The wearable patch of claim 6, wherein the sensing unit includes a pressure sensor or a force sensor configured to measure the user's blood pressure and/or the user's pulse, wherein the measurement signal comprises pulse data and blood pressure data.

15. The wearable patch of claim 6, wherein the sensing unit includes a first electrode that is configured to measure an electrical signal from the user's body in conjunction with the two electrodes attached to the stretchable substrate.

16. The wearable patch of claim 6, wherein the semiconductor chip is configured to switch the circuit, the two electrodes, and the sensing unit into or off from a measurement mode and a treatment mode.

17. The wearable patch of claim 6, wherein the sensing unit includes an accelerometer configured to measure movement of the user.

18. The wearable patch of claim 6, wherein the sensing unit includes a pressure sensor or a force sensor configured to measure blood pressure or pulse of the user.

19. The wearable patch of claim 6, wherein the semiconductor chip is configured to control the sensing unit based on the voltage applied across the user's body, wherein the semiconductor chip is configured to vary a frequency, or a duration of the measurement by the sensing unit.

20. The wearable patch of claim 6, further comprising: an antenna mounted on the circuit substrate and in electric connection with the semiconductor chip, wherein the semiconductor chip is configured to produce electric signals to enable the antenna to wirelessly exchange measurement data based on the measurement signal with an external device.

* * * * *

专利名称(译)	用于测量和治疗的双用途可穿戴贴片		
公开(公告)号	US20190021658A1	公开(公告)日	2019-01-24
申请号	US16/141794	申请日	2018-09-25
[标]申请(专利权)人(译)	VIVALNK		
申请(专利权)人(译)	VIVALNK INC.		
当前申请(专利权)人(译)	VIVALNK INC.		
[标]发明人	LI JIANG		
发明人	LI, JIANG		
IPC分类号	A61B5/00 A61N1/36 A61N1/04 A61B5/11 A61B5/024 A61B5/021 A61B5/01		
CPC分类号	A61B2562/164 A61N1/0492 A61B5/6815 A61B5/0008 A61B5/02438 A61B5/4836 A61B5/11 A61B5/01 A61B5/6832 A61N1/36014 A61B5/021 A61N1/36025 A61N1/36031		
外部链接	Espacenet USPTO		

摘要(译)

一种双用途可穿戴贴片，包括可拉伸和可渗透的基底，安装在可拉伸和可渗透基底中的感测单元，其中感测单元可以进行用户的测量以产生测量信号，一个或多个电极分别附着到可拉伸和可伸展的基底上。可渗透基板，可拉伸和可渗透基板上的电路基板，其中电路基板包括与一个或多个电极和感测单元电连接的电路，以及安装在电路基板上并与电路连接的半导体芯片。半导体芯片可以从感测单元接收测量信号并且可以产生治疗控制信号以控制一个或多个电极以在用户身体上施加电压。

