



US 20150305628A1

(19) **United States**

(12) **Patent Application Publication**
Zalev et al.

(10) **Pub. No.: US 2015/0305628 A1**

(43) **Pub. Date: Oct. 29, 2015**

(54) **PROBE ADAPTED TO CONTROL BLOOD FLOW THROUGH VESSELS DURING IMAGING AND METHOD OF USE OF SAME**

(52) **U.S. Cl.**
CPC *A61B 5/0095* (2013.01); *A61B 5/14552* (2013.01); *A61B 8/0825* (2013.01); *A61B 8/0891* (2013.01)

(71) Applicant: **SENO MEDICAL INSTRUMENTS, INC.**, San Antonio, TX (US)

(72) Inventors: **Jason Zalev**, Thornhill (CA); **Anthony Thomas Stavros**, Denver, CO (US)

(57) **ABSTRACT**

(73) Assignee: **SENO MEDICAL INSTRUMENTS, INC.**, San Antonio, TX (US)

(21) Appl. No.: **14/634,251**

(22) Filed: **Feb. 27, 2015**

Related U.S. Application Data

(60) Provisional application No. 61/945,557, filed on Feb. 27, 2014.

Publication Classification

(51) **Int. Cl.**
A61B 5/00 (2006.01)
A61B 8/08 (2006.01)
A61B 5/1455 (2006.01)

In an embodiment, an apparatus for opto-acoustic imaging includes a first contact area adapted to apply a first pressure to a surface of an imaging volume of a subject and a second contact area adapted to apply a second pressure to the surface. The second contact area is configured to provide decreased blood exit from the imaging volume by restricting flow relative to the first contact area. An optical energy output port is provided to illuminate the imaging volume to produce opto-acoustic signals from an absorbed optical energy of blood in the imaging volume. The opto-acoustic signals are detected by one or more ultrasound transducers and processed by a processor to generate images of the volume. An image generated by processing the detected opto-acoustic signals is output on a display.

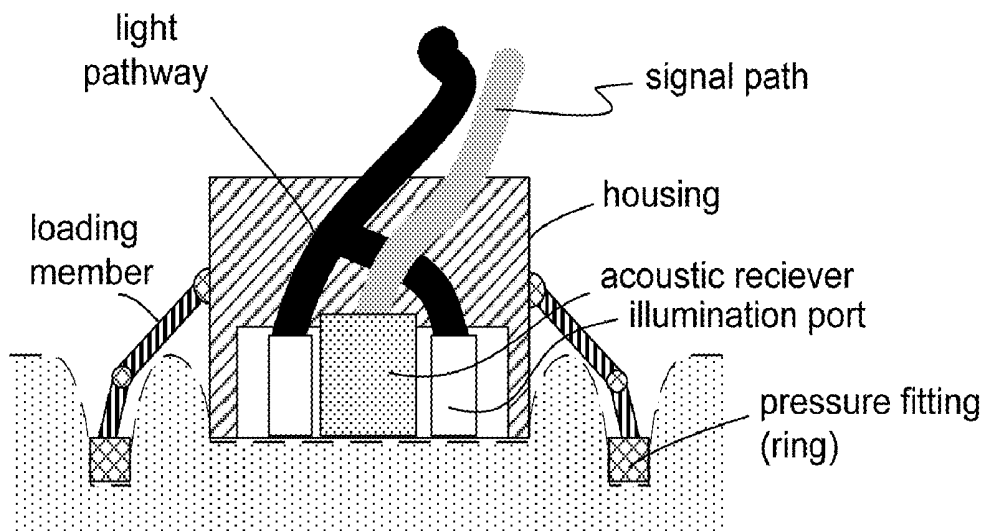

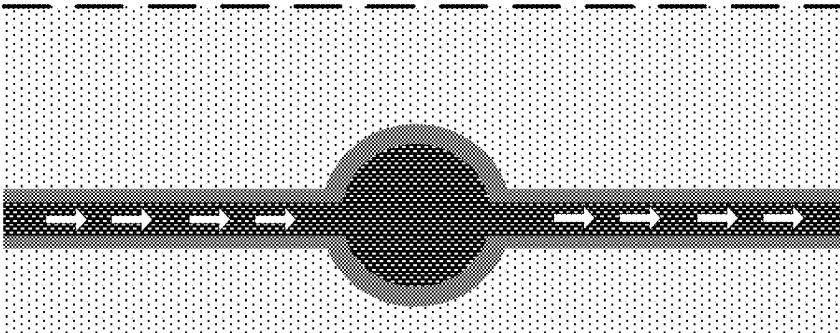

FIG. 1A

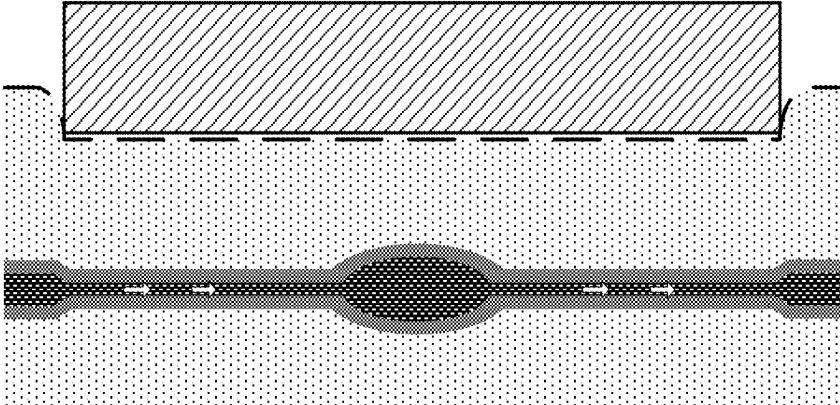
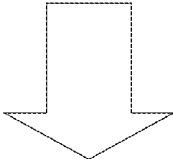

FIG. 1B

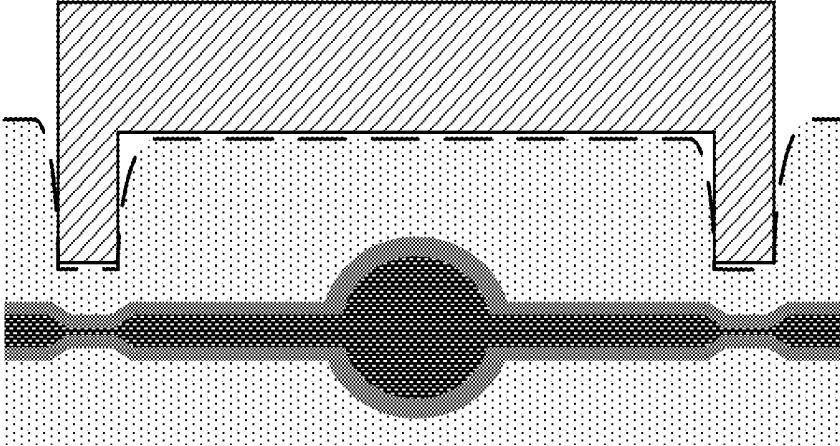
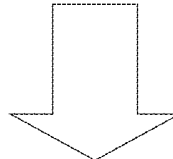

FIG. 1C

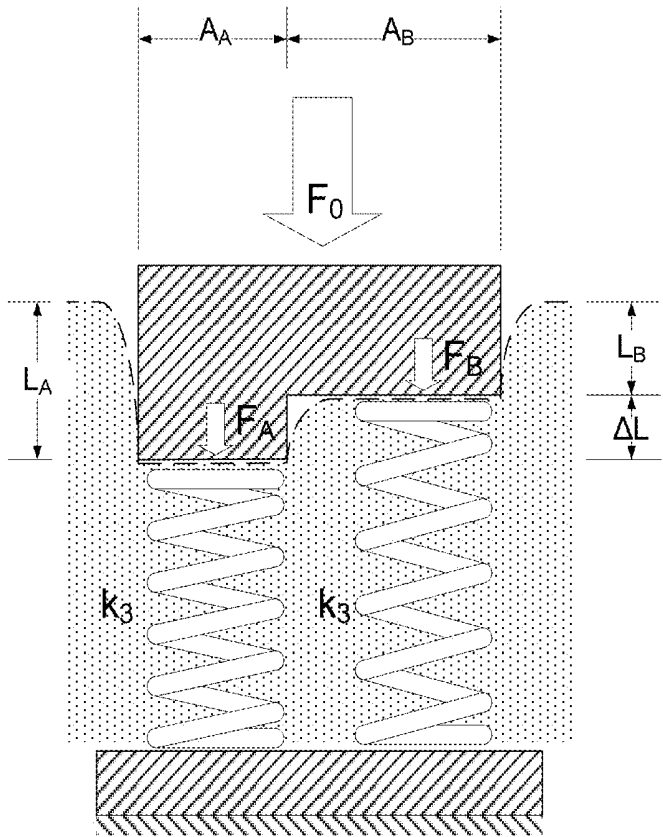

FIG. 2

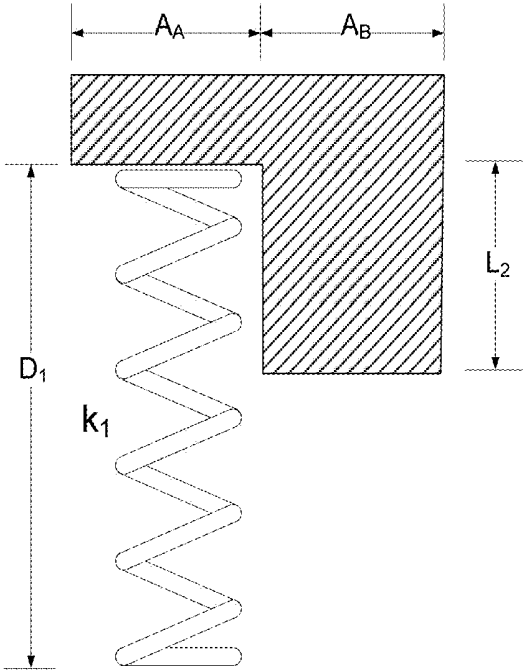

FIG. 3

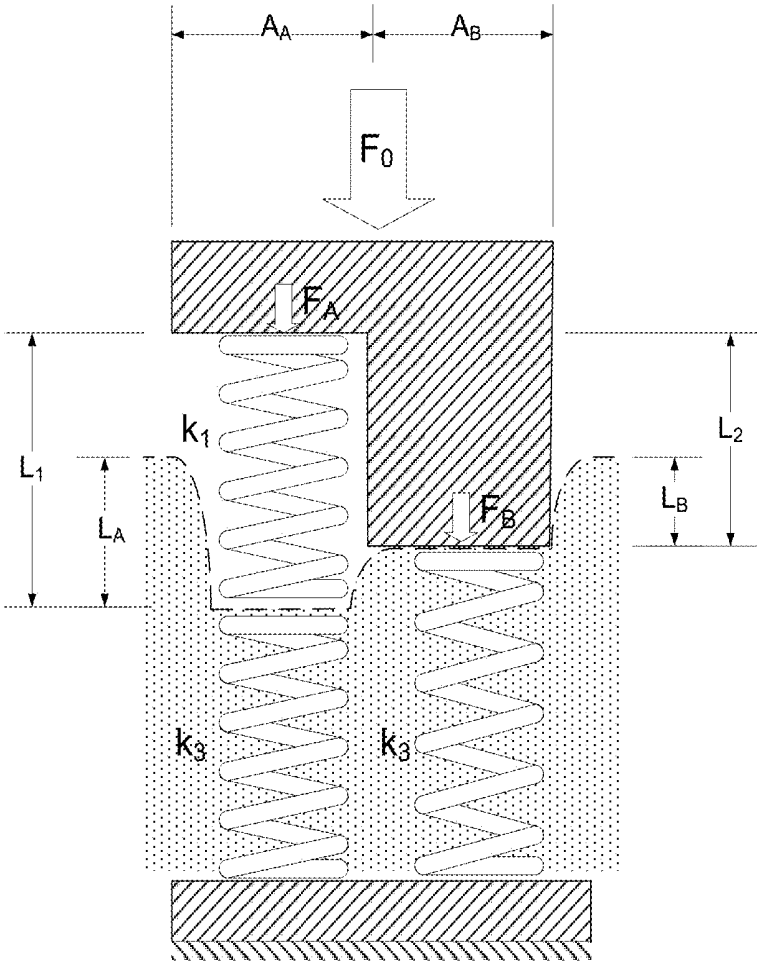

FIG. 4

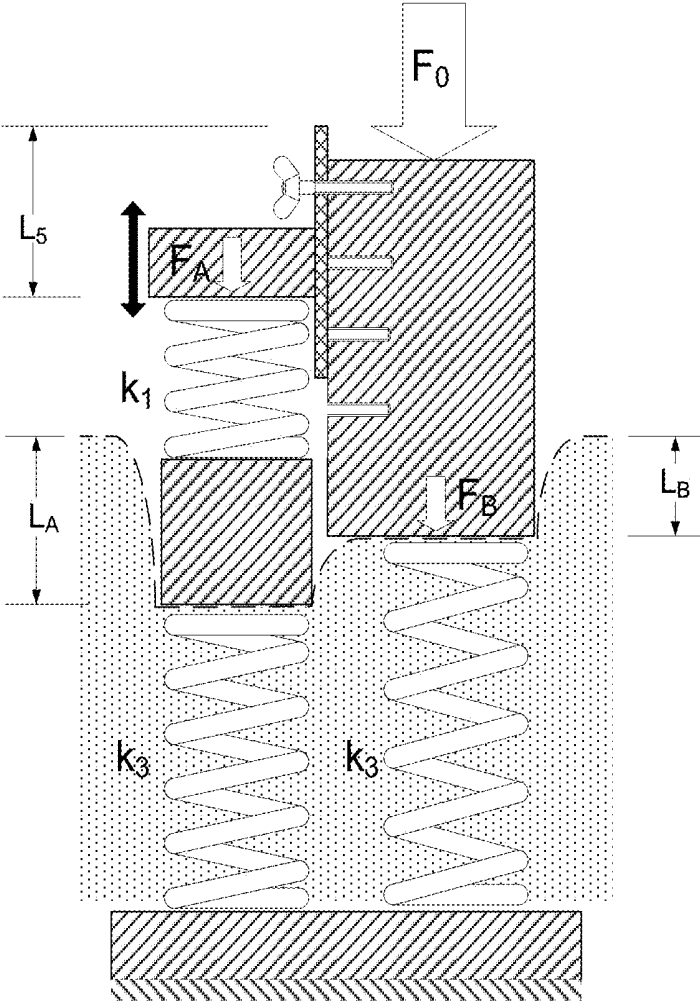

FIG. 5

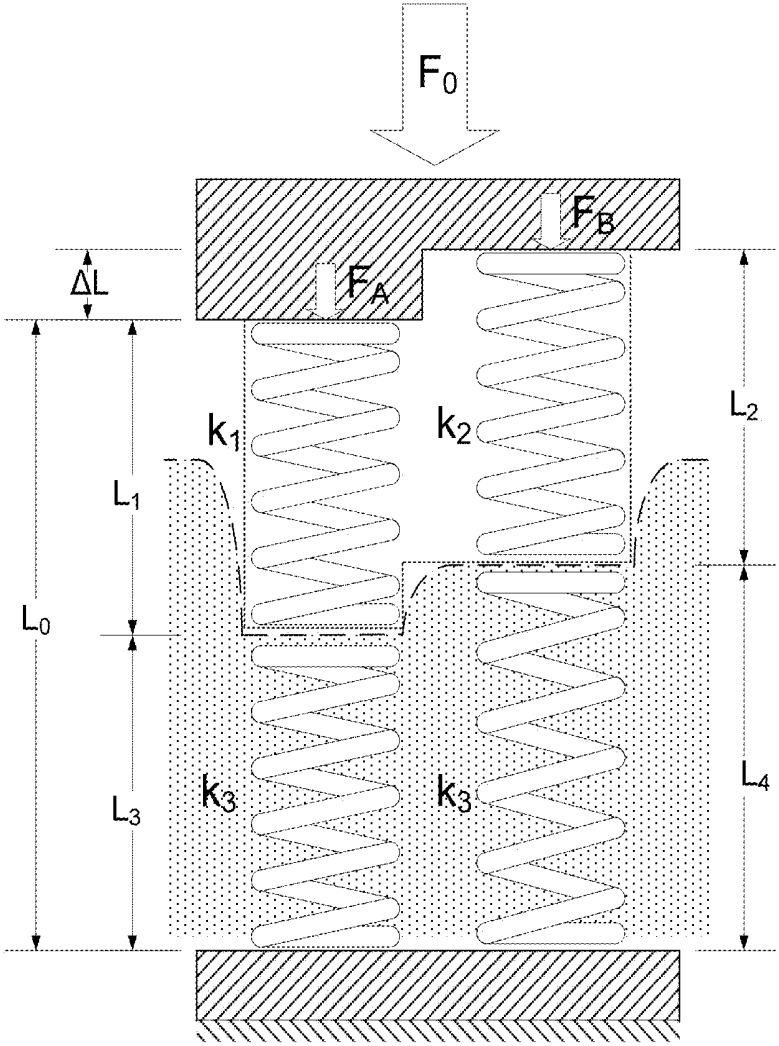

FIG. 6

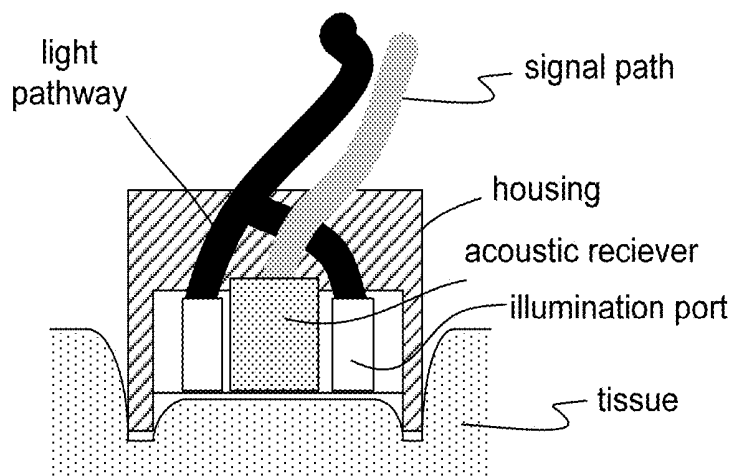

FIG. 7

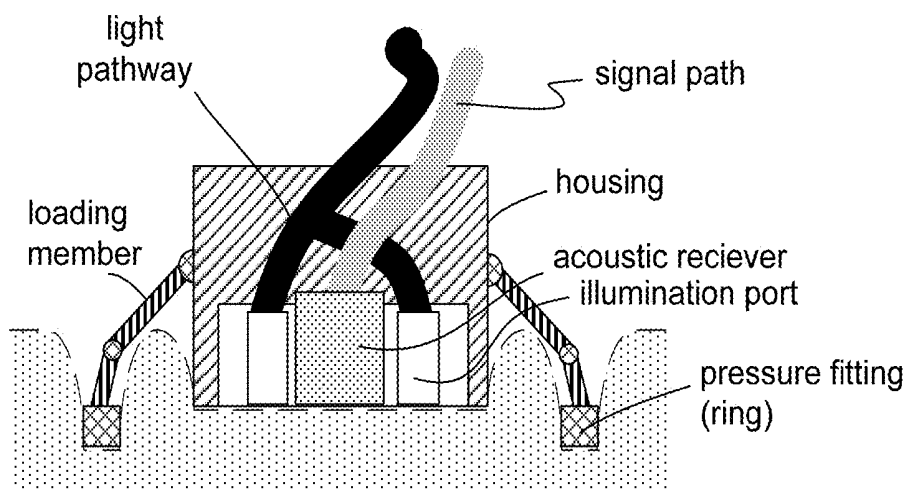

FIG. 8

**PROBE ADAPTED TO CONTROL BLOOD
FLOW THROUGH VESSELS DURING
IMAGING AND METHOD OF USE OF SAME**

[0001] This application is a non-provisional of and claims priority to U.S. Provisional Patent Application No. 61/945, 557 filed Feb. 27, 2014. The entire disclosure of that application, including the appendix thereto, is incorporated herein by reference. This application includes material which is subject to copyright protection. The copyright owner has no objection to the facsimile reproduction by anyone of the patent disclosure, as it appears in the Patent and Trademark Office files or records, but otherwise reserves all copyright rights whatsoever. This application relates to probes for use in connection with opto-acoustic imaging systems such as those described in U.S. patent application Ser. No. 14/512,896 filed Oct. 13, 2014, the entire disclosure of which is incorporated herein by reference.

FIELD

[0002] The present invention relates in general to the field of medical imaging, and in particular to an optoacoustic probe adapted to control blood flow through vessels during imaging.

BRIEF DESCRIPTION OF THE DRAWINGS

[0003] Objects, features, and advantages of the invention will be apparent from the following description of preferred embodiments as illustrated in the accompanying drawings, in which reference characters refer to the same parts throughout the various views. The drawings are not necessarily to scale, emphasis instead being placed upon illustrating principles of the invention. While the invention is amenable to various modifications and alternative forms, specifics thereof are shown by way of example in the drawings and will be described in detail. It should be understood, however, that the intention is not to limit the invention to the particular embodiments described. On the contrary, the intention is to cover all modifications, equivalents, and alternatives falling within the spirit and scope of the invention.

[0004] FIG. 1A shows a cross-sectional diagram of soft tissue with no object pressing against the tissue.

[0005] FIG. 1B shows a cross-sectional diagram of soft tissue with a flat object compressing the soft tissue.

[0006] FIG. 1C shows a cross-sectional diagram of soft tissue with an object having a protrusion causing increased pressure to be applied to the exterior region, thereby trapping blood in the interior region.

[0007] FIG. 2 shows a cross sectional diagram illustrating a model approximating tissue to obey linear elastic relations.

[0008] FIG. 3 shows a schematic diagram modeling indentation by a rigid member in accordance with an embodiment.

[0009] FIG. 4 shows a schematic diagram modeling indentation by a compressible member in accordance with an embodiment.

[0010] FIG. 5 shows a schematic diagram modeling indentation by a compressible member in accordance with an embodiment.

[0011] FIG. 6 shows a schematic diagram modeling indentation by multiple compressible members in accordance with an embodiment.

[0012] FIG. 7 shows a cross sectional diagram illustrating an opto-acoustic probe in accordance with an embodiment.

[0013] FIG. 8 shows a cross sectional diagram illustrating an opto-acoustic probe in accordance with an embodiment in which a pressure fitting is fitted around the probe to apply pressure to the tissue.

DETAILED DESCRIPTION

[0014] The following description and drawings are illustrative and are not to be construed as limiting. Numerous specific details are described to provide a thorough understanding. However, in certain instances, well-known or conventional details are not described in order to avoid obscuring the description. References to one or an embodiment in the present disclosure are not necessarily references to the same embodiment; and, such references mean at least one.

[0015] Reference in this specification to “one embodiment” or “an embodiment” means that a particular feature, structure, or characteristic described in connection with the embodiment is included in at least one embodiment of the disclosure. The appearances of the phrase “in one embodiment” in various places in the specification are not necessarily all referring to the same embodiment, nor are separate or alternative embodiments mutually exclusive of other embodiments. Moreover, various features are described which may be exhibited by some embodiments and not by others. Similarly, various requirements are described which may be requirements for some embodiments but not other embodiments.

[0016] The systems and methods are described below with reference to, among other things, block diagrams, operational illustrations and algorithms of methods and devices to process optoacoustic imaging data. It is understood that each block of the block diagrams, operational illustrations and algorithms and combinations of blocks in the block diagrams, operational illustrations and algorithms, can be implemented by means of analog or digital hardware and computer program instructions.

[0017] These computer program instructions can be provided to a processor of a general purpose computer, special purpose computer, ASIC, or other programmable data processing apparatus, such that the instructions, which execute via the processor of the computer or other programmable data processing apparatus, implements the functions/acts specified in the block diagrams, operational block or blocks and or algorithms.

[0018] In some alternate implementations, the functions/acts noted in the blocks can occur out of the order noted in the operational illustrations. For example, two blocks shown in succession can in fact be executed substantially concurrently or the blocks can sometimes be executed in the reverse order, depending upon the functionality/acts involved.

[0019] Reference will now be made in more detail to various embodiments of the present invention, examples of which are illustrated in the accompanying drawings and the Appendix. As will be apparent to one of skill in the art, the calculations described in the Appendix and processing steps described in the Appendix may be implemented in a variety of other ways without departing from the spirit of the disclosure and scope of the invention herein. The Appendix is intended to show one manner of implementing the concepts disclosed herein the purpose of illustration and to facilitate understanding.

[0020] When an operator applies pressure to a probe that images tissue, blood may be flowed out of vessels or blood flow to vessels can be reduced. This problem may occur in Doppler ultrasound and other applications. In certain circum-

stances, to acquire clear images of vessels in Doppler ultrasound, an operator applies minimal pressure to avoid reducing blood flow, so the visibility of vessels is not reduced. In opto-acoustics, applying high pressure can also cause blood to flow out of vessels. However, in general applications of opto-acoustics, blood does not have to be flowing to be detected.

[0021] The methods and devices described herein provide illustrative examples of the subject invention including a probe for opto-acoustic imaging adapted to apply different pressure to different regions on the surface of tissue. In an embodiment, the methods and devices described herein control blood flow to a region being imaged. In an embodiment, the methods and devices described herein are applied to probes used for other types of testing. In an embodiment, the methods and devices described herein are applied to probes used for other medical or non-medical procedures involving tissue. In an embodiment, the methods and devices described herein are fitted or otherwise applied to instruments besides handheld probes, including scopes, instruments, equipment, and other apparatus used for imaging, testing, and other medical and non-medical procedures involving tissue.

[0022] In an embodiment, the methods and devices described herein are used for opto-acoustic imaging including, for example, breast imaging of tumors. It has been observed that applying high pressure with a probe can cause blood to flow out of vessels, which in some instances may reduce the quality of imaging tumors. In an embodiment, a probe adapted for opto-acoustic imaging, can be fitted to apply pressure to a region surrounding or adjacent to the imaging region, with a pressure different from the pressure applied over the imaging region, thereby controlling blood flow to the imaging region. In an embodiment, the imaging region comprises an acoustic receiver.

[0023] The concept is illustrated in FIG. 1. Cross-sectional diagrams of soft tissue (e.g., breast tissue) are shown in FIGS. 1A, 1B and 1C. A feeding blood vessel is shown providing blood to a tumor, along with a draining vessel where blood can flow out of the tumor. In FIG. 1A, no object is pressing against the tissue. The tumor receives the full amount of blood and blood flows fully in the feeding and draining vessels. In FIG. 1B, a flat object is shown compressing the soft tissue. In the embodiment shown, the tumor and vessels are compressed, and less blood flows and less blood is contained in the tumor. In FIG. 1C, an object with a protrusion (e.g., a probe with a cup shaped appendage) is shown. The protrusion can cause increased pressure to be applied to the exterior region, thereby trapping blood in the interior region. The vessels directly under the protrusion are shown to be compressed, which restricts flow. Thus, in opto-acoustics, a probe (or other imaging setup) with the geometry described in FIG. 1c can create a beneficial situation for imaging when the blood is trapped in the lesion.

[0024] In embodiments, various amounts of pressure are applied to different regions of a surface of tissue, and the depth of deformation (a.k.a., strain, indentation) that occurs beneath a particular region. A mechanical model of the situation yields information for design of such an apparatus. More complex models are possible.

[0025] In FIG. 2, a model approximating tissue to obey linear elastic relations is shown in cross-section. The diagram in FIG. 2 is a simplified model to show linear elastic relations of tissue indentation for using a rigid member. The linear elastic relations represented here can be applied to the

embodiment of FIG. 1C even though FIG. 1C may look different than FIG. 2; the proper equations for the different looking shape are encompassed by the simplified model as shown, as would be apparent to one skilled in the art. In the model, the tissue compressibility is shown diagrammatically as a spring with a spring constant, the value of which is k_3 . The operator applies a force F_0 to the object as shown. The object has two faces, A and B, that contact the tissue. The surface area of the faces are A_A and A_B respectively. The face areas are not necessarily rectangular, but indicate the total surface area for a face of type A and for a face of type B. The faces of each type can, in different embodiments, be formed into many different shapes that are equivalent to the model. Face A protrudes further than face B by a distance of ΔL , as shown. If it is desired that face B protrudes greater than face A, then ΔL can be assigned a negative value. The depth of tissue indentation for the faces are L_A and L_B . The schematic shown in FIG. 2 is also applicable to the situation of FIG. 1C, where a cup surrounds an inner region (In this case, they are the same if FIG. 2 is revolved about an axis). In an embodiment, sufficient force is applied so that both faces are in contact with the tissue. As shown in the calculations in the appendix,

$$L_A = F_0 / ((A_A + A_B) * k_3) + A_B * \Delta L / (A_A + A_B),$$

and

$$L_B = F_0 / ((A_A + A_B) * k_3) - A_A * \Delta L / (A_A + A_B) = L_A - \Delta L.$$

[0026] The pressure underneath each face is given by

$$P_A = k_3 * L_A,$$

and

$$P_B = k_3 * L_B.$$

[0027] In the equations and models shown herein, the relations between pressure and force (PRESSURE=FORCE/AREA) are assumed to be handled appropriately, and when solving equations, one skilled in the art will know in which circumstances an equation requires the use of pressure units rather than force units. Force is the integral of pressure with respect to area.

[0028] Of further interest is the situation where the probe comprises soft materials that may be compressed. The compressibility of the probe material also determines the depths of deformation, and the pressure applied to each region. Furthermore, in an embodiment, for a given amount of operator force, the compressibility of the probe material can allow greater control of the pressure applied to each region, in particular, to control the pressure in the imaging region.

[0029] FIG. 3 shows a schematic with a compressible member. The length D_1 is the uncompressed length of the compressible member. L_2 is the protruding length of an incompressible member (representing, e.g., an imaging region). The schematic is applicable to a compressible cup (e.g. made of rubber, foam or soft material, etc.) around a probe if FIG. 3 is revolved about an axis. FIG. 4 shows this probe applied to tissue in cross-section. In FIG. 4, the compressible member is compressed, so the length is called L_1 , which is the compressed length, not the uncompressed length, D_1 . As before, the depth of tissue indentation for the faces are L_A and L_B , and the surface area of the faces are A_A and A_B . It is shown in the calculations in the appendix that:

$$L_A = (k_1/k_3 * F_0 + A_B * (D_1 - L_2) * k_1) / (k_1 * A_A + (k_1 + k_3) * A_B),$$

and

$$L_B = ((k_1 + k_3) / k_3 * F_0 - A_A * (D_1 - L_2) * k_1) / (k_1 * A_A + (k_1 + k_3) * A_B).$$

[0030] Thus, in an embodiment, the surface pressure and tissue indentation can be controlled by designing a probe with appropriate parameters A_A , A_B , k_1 , D_1 and L_2 . In an embodiment, the depth of indentation (and the pressure) of a face increases when the surface area of that face decreases. This is the “knife” effect, where if the same force were applied to a very small surface area, a high pressure and indentation would result over a small surface area. Furthermore, in an embodiment, when k_1 is increased, this causes the indentation of face A to increase, and of face B to potentially decrease. Thus, in an embodiment, when a compressible material is used to apply pressure to the exterior region, the protruding length D_1 of this compressive member may be longer than if it were an incompressible member (i.e., where $D_1 = L_1$ and k_1 is large) to have the same effect.

[0031] In an embodiment shown in FIG. 5, adjustable compressibility parameters are used. In an embodiment, the probe has a mechanism to adjust the protruding length. In an embodiment, the adjustment is electronically controlled. The adjustment may occur inside of the probe, and is not limited to what is shown in the schematic. The schematic of FIG. 5 shows a manually adjustable protruding length of the probe. In a similar manner it may also be possible to manually or electronically control the compressibility, not only just the protruding length. FIG. 5 also illustrates that an incompressible member may be placed on the distal surface of a probe that is attached to the compressible member. In an embodiment, this may correspond to an illumination member (e.g. light bar, light path, optical window, diffuser), or an alternate embodiment, an acoustic receiver. The member may also be optically reflective, optically transparent, or acoustically absorbing.

[0032] A method for diagnosis using different settings of compression is now described. The metabolism of tissue (and tumors) consume oxygen from the blood supply. When the blood flow is constricted, the oxygenation level of the tumor (and tissue) may be reduced. In such circumstances, different types of tissues or structures may exhibit different metabolic behavior for the constricted or non-constricted cases. For example, when constricted, a malignancy might become very much more strongly deoxygenated than a benign mass in the same circumstances. Furthermore, the rates at which the oxygenation levels of the lesion become deoxygenated may be dependent upon the metabolic factors of the tissue. These rates may also be examined.

[0033] Accordingly, a method is described wherein a volume of tissue is imaged with an opto-acoustic imaging apparatus, comprising: configuring the apparatus to collect data for imagery of tissue using at least one optical illumination wavelength for a first configuration of applied surface pressure; reconfiguring the apparatus to collect data for imagery of tissue using at least one optical illumination wavelength for a second configuration of applied surface pressure, where the second configuration of applied surface pressure is configured to trap blood or reduce flow in the imaging region more so than in the first configuration; analyzing the first data for imagery and second data for imagery to determine the difference in at least one parameter; and creating an image of

the at least one parameter as spatially represented in the volume. In an embodiment, the at least one parameter is selected from: blood oxygen saturation, blood volume, optical fluence, or other property. In an embodiment, data from a continuum of applied surface pressure configurations is acquired by applying incremental changes to the surface pressure configuration and collecting data for imagery at each increment. In an embodiment, this is done by increasing a length (e.g. L_5 as shown in FIG. 5). As an example, in an embodiment, the first configuration could use a length L_5 of 0 cm, and the second configuration could use a length L_5 of 1 cm. As described herein, other configurations are possible. In an embodiment, it can be electronically controlled. In an embodiment, the first and second data for imagery are analyzed by subtractive analysis. In an embodiment, for an amount of time following the event of applying (or releasing) of the blood trapping pressure configuration, multiple frames of data are collected, where each frame corresponds to a time since the event, and creating output corresponding to the time domain behavior of metabolic or blood flow activity that is produced from the multiple frames. In an embodiment, an image that represents change per unit time of the at least parameter, as spatially represented in the tissue is presented. In an embodiment, the rate of de-oxygenation (e.g. of the tumor of tissue) is presented. In an embodiment the rate of blood returning flow is presented.

[0034] Force (or pressure), or distance sensors may be positioned on faces of the probe or other instrument. In an embodiment, there is a desired pressure (or distance) that is optimal for imaging. For example, low non-zero pressure to the imaging region, and high pressure to the constrictive region. An indicator on the screen can be presented to the operator to indicate applying more, less, or sufficient pressure. In an embodiment, the pressure sensor can be used to control the adjustable compressibility automatically. For example, if a desired constrictive pressure is not met, the constrictive pressure can be increased. Also, for example, if contact is not made with the acoustic receiver, adjustment can be made to allow contact without varying the operator force.

[0035] In an embodiment, the compressibility of the tissue, k_3 , can be measured. This can be done by solving the above equations. This may involve sensors for (directly or indirectly) measuring L_A and/or L_B and/or F_0 .

[0036] In FIG. 6, multiple compressive members are shown in cross-section to illustrate a scenario where multiple compressive members are present, which can be solved similar to equations described in the appendix.

[0037] In FIG. 7, a cross-section of an embodiment of an opto-acoustic probe is shown. Different light delivery and acoustic receiver configurations are possible.

[0038] In FIG. 8, a cross-section of an embodiment of an opto-acoustic probe is shown. A pressure fitting, such as a ring or a cup, can be fitted around the probe to apply pressure to the tissue. The loading member can attach the fitting to the probe. In an embodiment, the loading member may permit the ring to be engaged or disengaged, or have the amount of pressure be varied, or adjusted.

[0039] In an embodiment, the probe can automatically apply a desired pressure (and/or a desired indentation) to one or both of the contact areas of the probe. In an embodiment, this can be done dynamically based on an amount of force applied by an operator. In an embodiment, a control unit can adjust the amount of force, pressure and/or distance that is distributed to one or more contact regions by an applied force.

In an embodiment, the pressure applied to one of the regions of tissue can be controlled by an opto-acoustic probe.

[0040] In an embodiment, the dynamic probe comprises ultrasonic transducers to receive acoustic signals produced in response to absorption of optical energy, a first contact area to apply a first force to a first region of tissue, a second contact area to apply a second force to a second region of tissue, one or more sensors to measure at least one of the first force and the second force, and an adjustable member with a setting to adjust or set the first force. In an embodiment, the adjustable member is controlled electronically. In an embodiment, the pressure can be controlled by performing the following steps: a.) setting the adjustable member to an initial configuration; b.) recording a measurement from the one or more sensors (after the probe has been placed into contact with the tissue); c.) changing the setting of the adjustable member based upon the measurement from the one or more sensors; and, d.) repeating steps b.) and c.) until a desired pressure applied to the first region of tissue is reached. The volume can then be illuminated with electromagnetic energy to produce opto-acoustic acoustic signals using optimal application of forces.

[0041] In an embodiment, dynamic adjustment is applied to a handheld probe. A total applied force is applied to the probe by an operator, wherein a portion of the total applied force is distributed to the first force that is applied to the first region of tissue. In an embodiment, the probe comprises a sensor for measuring the total applied force, in addition to a sensor for measuring one other force. In an embodiment, a force sensor can be implemented by measuring distance and converting to force. In an embodiment, the desired pressure setting applied to a region equals a fixed proportion of the total applied force. In an embodiment, 80% of the applied force is applied to the pressure fitting. In an embodiment, between 80% and 100% of applied pressure is applied to the pressure fitting. In an embodiment, a configuration setting of between 10% and 90% of the applied force and/or applied pressure is applied to the pressure fitting. In an embodiment, a configuration setting of 0% of the applied force is applied to the pressure fitting, the pressure fitting being disengaged. In an embodiment, a configuration setting of 100% of the applied force is applied to the pressure fitting, the transducer being disengaged or lightly contacting but remaining coupled to the volume. In an embodiment, the force applied to the pressure fitting is set to apply a minimal force to the transducer while the transducer remains coupled. In an embodiment, when substantially zero force is applied to the transducer (and substantially 100% force is applied to the pressure fitting), and the transducer remains coupled, other physical principles (e.g. attractive forces) may serve to keep the transducer coupled. In an embodiment, applying low force to the imaging region prevents squeezing of blood out of vessels for imaging even while flow is reduced to the vessels by the pressure fitting. In an embodiment, the total applied force is equal to the sum of force for the first region plus force for the second region. In an embodiment, the sensor for measuring the total applied force computes a sum of a measurement from a sensor for measuring force for the first region and a measurement from a sensor for measuring the force for the second region. In an embodiment, a force sensor, a pressure sensor, and/or a distance sensor may be used to compute a force.

[0042] In an embodiment, changing the setting of the adjustable member can be done by: determining a value of pressure applied to the first region of tissue by processing the measurements of one or more sensors; computing a differ-

ence between a desired pressure for first region of tissue and the determined immediate value for pressure for the first region of tissue; determining an amount for the setting change based upon the computed difference; and changing the setting of the adjustable member by the determined amount.

[0043] In an embodiment where the ultrasonic transducers are located on the second contact area, the second region of tissue comprises an imaging volume comprising blood. The desired pressure applied to the first region of tissue can decrease blood exit from the imaging volume by restricting flow. It should be apparent that the flow can be restricted moreso than if the contact region for the imaging volume were used in isolation (e.g. without a pressure fitting), as blood would be pushed out by force applied to the contact area for the imaging region and/or any constriction by the pressure fitting would not occur. This can improve quality in an image representing absorbed optical energy of blood within the imaging volume.

[0044] In an embodiment, an image spatially representing the difference between two configurations is produced and displayed. In an embodiment, this is done by imaging one configuration as described above and the performing the following steps to achieve another configuration: repeating the above steps b.) and c.) until a second desired pressure applied to the first region of tissue is reached; illuminating the volume with optical energy in this configuration to produce additional acoustic signals that are received by the ultrasonic transducers; and processing the acoustic signals from both configurations to determine a difference of absorbed optical energy for the first desired pressure and the second desired pressure; and, outputting to a display an image spatially representing the difference. In an embodiment, the image is of a lesion in breast tissue.

[0045] The present devices and methods are described above with reference to block diagrams and operational illustrations. It is understood that each block of the block diagrams or operational illustrations, and combinations of blocks in the block diagrams or operational illustrations, may be implemented by means of analog or digital hardware and computer program instructions. These computer program instructions may be provided to a processor of a general purpose computer, special purpose computer, ASIC, FPGA or other programmable data processing apparatus, such that the instructions, which execute via the processor of the computer or other programmable data processing apparatus, implements the functions/acts specified in the block diagrams or operational block or blocks. In some alternate implementations, the functions/acts noted in the blocks may occur out of the order noted in the operational illustrations. For example, two blocks shown in succession may in fact be executed substantially concurrently or the blocks may sometimes be executed in the reverse order, depending upon the functionality/acts involved.

[0046] As used in this description, “a” or “an” means “at least one” or “one or more” unless otherwise indicated. In addition, the singular forms “a”, “an”, and “the” include plural referents unless the content clearly dictates otherwise. Thus, for example, reference to a composition containing “a compound” includes a mixture of two or more compounds.

[0047] As used in this specification, the term “or” is generally employed in its sense including “and/or” unless the content clearly dictates otherwise.

[0048] The recitation herein of numerical ranges by endpoints includes all numbers subsumed within that range (e.g. 1 to 5 includes 1, 1.5, 2, 2.75, 3, 3.80, 4, and 5).

[0049] Unless otherwise indicated, all numbers expressing quantities of ingredients, measurement of properties and so forth used in the specification and claims are to be understood as being modified in all instances by the term “about,” unless the context clearly dictates otherwise. Accordingly, unless indicated to the contrary, the numerical parameters set forth in the foregoing specification and attached claims are approximations that can vary depending upon the desired properties sought to be obtained by those skilled in the art utilizing the teachings of the present invention. At the very least, each numerical parameter should at least be construed in light of the number of reported significant digits and by applying ordinary rounding techniques. Any numerical value, however, inherently contains certain errors necessarily resulting from the standard deviations found in their respective testing measurements.

[0050] Those skilled in the art will recognize that the methods and devices of the present disclosure may be implemented in many manners and as such are not to be limited by the foregoing exemplary embodiments and examples. In other words, functional elements being performed by single or multiple components, in various combinations of hardware and software or firmware, and individual functions, may be distributed among software applications at either the client level or server level or both. In this regard, any number of the features of the different embodiments described herein may be combined into single or multiple embodiments, and alternate embodiments having fewer than, or more than, all of the features described herein are possible. Functionality may also be, in whole or in part, distributed among multiple components, in manners now known or to become known. Thus, myriad software/hardware/firmware combinations are possible in achieving the functions, features, interfaces and preferences described herein. Moreover, the scope of the present disclosure covers conventionally known manners for carrying out the described features and functions and interfaces, as well as those variations and modifications that may be made to the hardware or software or firmware components described herein as would be understood by those skilled in the art now and hereafter.

[0051] Furthermore, the embodiments of methods presented and described as flowcharts in this disclosure are provided by way of example in order to provide a more complete understanding of the technology. The disclosed methods are not limited to the operations and logical flow presented herein. Alternative embodiments are contemplated in which the order of the various operations is altered and in which sub-operations described as being part of a larger operation are performed independently.

[0052] Various modifications and alterations to the invention will become apparent to those skilled in the art without departing from the scope and spirit of this invention. It should be understood that the invention is not intended to be unduly limited by the specific embodiments and examples set forth herein, and that such embodiments and examples are presented merely to illustrate the invention, with the scope of the invention intended to be limited only by the claims attached hereto. Thus, while the invention has been particularly shown and described with reference to a preferred embodiment thereof, it will be understood by those skilled in the art that

various changes in form and details may be made therein without departing from the spirit and scope of the invention.

APPENDIX TO THE SPECIFICATION

Pressure/Force/Area Relations

[0053]

$$A0=AA+AB \tag{1.1}$$

$$P = \frac{F}{A} \quad P = \frac{F}{A} \tag{1.2}$$

$$F0=FA+FB \tag{1.3}$$

$$P0 \cdot A0=PA \cdot AA+PB \cdot AB \tag{1.4}$$

$$P0 \cdot A0=PA \cdot AA+PB \cdot AB \tag{1.5}$$

$$F0=P0 \cdot A0 \tag{1.6}$$

$$FA=PA \cdot AA \tag{1.7}$$

$$FB=PB \cdot AB \tag{1.8}$$

Spring Energy

[0054] Let the compression of the spring be x_1 , and the compression of the tissue be $LA=x_3$, then the total compression is x_0 .

The energy is given by:

$$E=kl \cdot x_1^2+k3 \cdot x_3^2 \tag{2.1}$$

With the total compression x_0 :

$$x_1+x_3=x_0 \tag{2.2}$$

substitute in for x_3 :

$$E=k1x_1^2+k3(x_0-x_1)^2 \tag{2.3}$$

Setting $dE=0$, and solving for x_1 , we get:

$$x_1 = \frac{k3x_0}{k1+k3} \tag{2.4}$$

Thus x3 is:

[0055]

$$x3 = \text{solve}(\text{eval}((2.2),(2.4)),x3)$$

$$x3 = \frac{x0k1}{k1 + k3} \tag{2.5}$$

$$x3 := LA$$

$$LA \tag{2.6}$$

Thus the total compression in path A is:

$$x0 = \text{solve}(\text{eval}((2.2),(2.4)),x0)$$

$$x0 = \frac{LA(k1 + k3)}{k1} \tag{2.7}$$

or the compressed spring length, in terms of tissue length is:

$$\text{eval}((2.4),(2.7))$$

$$x1 = \frac{k3 LA}{k1} \tag{2.8}$$

Forces Applied to the Tissue

[0056] In the spring/tissue path, we have an effective spring constant k_eff:

$$k_{eff} = \left(\frac{1}{k1} + \frac{1}{k3}\right)^{-1} \quad k_{eff} = \frac{1}{\frac{1}{k1} + \frac{1}{k3}} \tag{3.1}$$

So the total pressure force in path A is:

$$PA = k_{eff}x0$$

$$PA = k_{eff}x0 \tag{3.2}$$

Thus FA is:

[0057]

$$FA = \text{eval}(PA \cdot AA, (3.2))$$

$$FA = k_{eff}x0AA \tag{3.3}$$

Or expanded out:

$$\text{simplify}(\text{eval}((3.2),(3.1)))$$

$$PA = \frac{k1 k3 x0}{k1 + k3} \tag{3.4}$$

And the total pressure force in path B is:

$$PB = k3 \cdot LB$$

$$PB = k3LB \tag{3.5}$$

And thus FB is:

$$FB = \text{eval}(PB \cdot AB, (3.5))$$

$$PB = k3LB \tag{3.6}$$

So assuming both paths are in contact with the tissue, F0 is FA+FB:

$$F0 = \text{eval}(FA + FB, \{(3.3),(3.6)\})$$

$$F0 = k_{eff}x0AA + k3LB \tag{3.7}$$

which is to say:

$$\text{collect}(\text{simplify}(\text{eval}((3.7),(3.1))), [x0, LB], \text{factor})$$

$$F0 = \frac{k3 k1 AA x0}{k1 + k3} + k3 LB \tag{3.8}$$

And we can also simplify it to an expression that could be directly written as:

$$\text{eval}((3.8),(2.7))$$

$$F0 = k3AA LA + k3LB \tag{3.9}$$

Which is:

[0058]

$$\text{collect}((3.9), k3, \text{sort})$$

$$F0 = (AA LA + AB LB)k3 \tag{3.10}$$

original length of spring 1:

$$D1 = L1 + x1$$

$$D1 = L1 + x1 \tag{3.11}$$

difference between uncompressed spring length D1 and fixed baffle length L2 is:

$$DL = (D1) - L2$$

$$DL = (D1) - L2 \tag{3.12}$$

So the compressed spring length L1 is:

$$L1 = \text{solve}((3.11), L1)$$

$$L1 = -x1 + D1 \tag{3.13}$$

difference between compressed spring and fixed baffle length is the same as the difference in tissue compressions

$$L1 - L2 = LA - LB$$

$$L1 - L2 = LA - LB \tag{3.14}$$

Thus:

$$\text{eval}((3.14),(3.13))$$

$$-x1 + D1 - L2 = LA - LB \tag{3.15}$$

And from above, we can find LB in terms of LA as:

$$LB = \frac{LA(k1 + k3)}{k1} - D1 + L2 \quad (3.16)$$

We can substitute this back into the expression for F0

$$F0 = \left(AA \frac{LA(k1 + k3)}{k1} + AB \left(\frac{LA(k1 + k3)}{k1} - D1 + L2 \right) \right) k3 \quad (3.17)$$

And this yields the solution to the tissue compressed distances LA and LB in terms of the applied force F0,

$$LA = \frac{k1 F0}{(k1 AA + AB k1 + k3 AB)k3} + \frac{AB(D1 - L2)k1}{k1 AA + AB k1 + k3 AB} \quad (3.18)$$

$$LB = \frac{(k1 + k3)F0}{(k1 AA + AB k1 + k3 AB)k3} - \frac{k1 AA(D1 - L2)}{k1 AA + AB k1 + k3 AB} \quad (3.19)$$

The Pressure PB over the tissue in terms of the force thus:

$$PB = \frac{(k1 + k3)F0}{k1 AA + AB k1 + k3 AB} - \frac{k1 AA(D1 - L2)k3}{k1 AA + AB k1 + k3 AB} \quad (3.21)$$

And the pressure PA over the tissue in terms of the force is:

$$PA = \frac{k1 F0}{k1 AA + AB k1 + k3 AB} - \frac{k1 AB(D1 - L2)k1}{k1 AA + AB k1 + k3 AB} \quad (3.22)$$

In the limit as the spring becomes infinitely stiff:

$$LA = \frac{F0}{(AA + AB)k3} + \frac{(D1 - L2)AB}{AA + AB} \quad (3.23)$$

$$LB = \frac{F0}{(AA + AB)k3} - \frac{AA(D1 - L2)}{AA + AB} \quad (3.24)$$

$$PA = \frac{F0}{AA + AB} + \frac{(D1 - L2)k3 AB}{AA + AB} \quad (3.25)$$

$$PB = \frac{F0}{AA + AB} - \frac{AA(D1 - L2)k3}{AA + AB} \quad (3.26)$$

1. An apparatus, comprising:

- a first contact area adapted to apply a first pressure to a surface of an imaging volume of a subject;
- a second contact area adapted to apply a second pressure to the surface, the second contact area configured to provide decreased blood exit from the imaging volume by restricting flow relative to that of the first contact area;
- an optical energy output port adapted to illuminate the imaging volume to produce opto-acoustic signals from an absorbed optical energy of blood in the imaging volume, the opto-acoustic signals being detected by one or more ultrasound transducers and processed by a processor to generate images of the volume; and
- a display to output an image generated by processing the detected opto-acoustic signals.

2. The apparatus of claim 1, wherein the apparatus comprises a handheld probe configured for control by an operator such that the operator can apply a force to the handheld probe to bring the handheld probe into contact with the subject, wherein the first contact area and the second contact area distribute the force applied by the operator such that the first applied pressure is less than the second applied pressure.

3. The apparatus of claim 1, configured to provide for the use of a coupling medium between the first contact area and the surface of the imaging volume of the subject, wherein the one or more ultrasound transducers are located on the first contact area, and wherein the coupling medium improves detection of acoustic signals by the one or more ultrasound transducers.

4. The apparatus of claim 1, wherein the second contact area surrounds the first contact area to improve decrease of blood exit from the imaging volume.

5. The apparatus of claim 4, wherein the second contact area is on a pressure fitting that surrounds the first contact area, and the pressure fitting is attached to a handheld probe.

6. The apparatus of claim 1, wherein the second contact area is located on a member extending outward from an exterior surface of the probe.

7. The apparatus of claim 6, further comprising an adjustment mechanism configured to adjust a compressive force that is provided by the member during an imaging procedure.

8. The apparatus of claim 1, configured such that the first applied pressure of the first contact area causes an indentation

in the tissue that is less than an indentation in the tissue caused by the second applied pressure of the second contact area.

9. The apparatus of claim 1, wherein the first contact area is located on an incompressible member and the second contact area is located on a compressive member.

10. The apparatus of claim 1, wherein the first contact area is located on a first compressive member and the second contact area is located on a second compressive member.

11. The apparatus of claim 1, wherein the apparatus comprises a handheld probe configured for imaging of biological tissue, wherein the first contact area, the second contact area, the optical energy output port, and the one or more ultrasound transducers are located on the handheld probe.

12. A method, comprising the steps of:

bringing a probe adapted to apply a plurality of pressure configurations into contact with a volume of tissue, the probe comprising one or more ultrasound transducers; configuring the probe to apply a first pressure configuration to the volume of tissue;

illuminating the volume of tissue with light to produce first opto-acoustic signals while the first pressure configuration is being applied, the first opto-acoustic signals being detected by the one or more ultrasound transducers;

configuring the probe to apply a second pressure configuration to the volume of tissue;

illuminating the volume of tissue with light to produce second opto-acoustic signals while the second pressure configuration is being applied, the second optoacoustic signals being detected by the one or more ultrasound transducers;

processing the detected opto-acoustic signals of the first pressure configuration and the opto-acoustic signals of the second pressure configuration to determine a difference between the first and second configurations of at least one parameter; and

outputting an image representing the determined difference between the first and second configurations.

13. The method of claim 12, wherein the at least one parameter is selected from the group consisting of: a blood oxygen saturation, a blood volume, or an optical fluence.

14. The method of claim 12, wherein application of the second pressure configuration traps blood of an imaging region more than application of the first pressure configuration.

15. The method of claim 12, wherein application of the second pressure configuration reduces flow of an imaging region more than application of the first pressure configuration.

16. The method of claim 12, wherein the step of illuminating the volume of tissue during application of the first pressure configuration is repeated at a plurality of times following application of the first pressure configuration to capture a time domain behavior of a metabolic or a blood flow activity of the first pressure configuration.

17. The method of claim 12, wherein the step of illuminating the volume of tissue during application of the second pressure configuration is repeated at a plurality of times following application of the second pressure configuration to capture a time domain behavior of a metabolic or a blood flow activity of the second pressure configuration.

18. The method of claim 12, wherein an acoustic coupling medium is used between the probe and the volume of tissue.

19. A method for controlling pressure applied to a first region of tissue by an opto-acoustic probe, the opto-acoustic

probe comprising ultrasonic transducers to receive acoustic signals produced in response to absorption of optical energy, a first contact area to apply a first force to the first region of tissue, a second contact area to apply a second force to a second region of tissue, one or more sensors to measure at least one of the first force and the second force, and an adjustable member with a setting to adjust the first force, the method comprising the steps of:

- a. setting the adjustable member to an initial configuration;
- b. recording a measurement from the one or more sensors after the probe has been placed into contact with the tissue;
- c. changing the setting of the adjustable member based upon the measurement from the one or more sensors;
- d. repeating steps b-c until a desired pressure applied to the first region of tissue is reached;
- e. illuminating the volume with the optical energy to produce the acoustic signals that are received by the ultrasonic transducers.

20. The method of claim 19, wherein the opto-acoustic probe is a handheld probe and a total applied force is applied to the probe by an operator, wherein a portion of the total applied force is distributed to the first force that is applied to the first region of tissue, and wherein the probe further comprises a sensor for measuring the total applied force.

21. The method of claim 20, wherein the desired pressure equals a fixed proportion of the total applied force.

22. The method of claim 20, wherein the total applied force is equal to the sum of the first force plus the second force, and the sensor for measuring the total applied force computes a sum of a measurement from a sensor for measuring the first force and a measurement from a sensor for measuring the second force.

23. The method of claim 19, wherein the one or more sensors are selected from the group consisting of: a force sensor, a pressure sensor, and a distance sensor.

24. The method of claim 19, wherein the step of changing the setting of the adjustable member comprises the steps of: determining a value of pressure applied to the first region of tissue by processing the measurements of the one or more sensors;

computing a difference between the desired pressure for first region of tissue and the determined value of pressure for the first region of tissue;

determining an amount for the setting change based upon the computed difference; and

changing the setting of the adjustable member by the determined amount.

25. The method of claim 19, wherein the ultrasonic transducers are located on the second contact area, wherein the second region of tissue comprises an imaging volume comprising blood, and wherein the desired pressure applied to the first region of tissue decreases blood exit from the imaging volume by restricting flow.

26. The method of claim 25, further comprising a step of outputting an image representing absorbed optical energy of blood within the imaging volume.

27. The method of claim 19, further comprising the steps of:

repeating steps b-c until a second desired pressure applied to the first region of tissue is reached;

illuminating the volume with additional optical energy to produce additional acoustic signals that are received by the ultrasonic transducers;

processing the acoustic signals and the additional acoustic signals to determine a difference of absorbed optical energy for the first desired pressure and the second desired pressure; and, outputting to a display an image spatially representing the difference.

* * * * *

专利名称(译)	适于在成像期间控制通过血管的血流的探针及其使用方法		
公开(公告)号	US20150305628A1	公开(公告)日	2015-10-29
申请号	US14/634251	申请日	2015-02-27
[标]申请(专利权)人(译)	SENO医疗INSTR		
申请(专利权)人(译)	SENO医疗器械, INC.		
当前申请(专利权)人(译)	SENO医疗器械, INC.		
[标]发明人	ZALEV JASON STAVROS ANTHONY THOMAS		
发明人	ZALEV, JASON STAVROS, ANTHONY THOMAS		
IPC分类号	A61B5/00 A61B8/08 A61B5/1455		
CPC分类号	A61B5/0095 A61B8/0891 A61B8/0825 A61B5/14552 A61B5/022 A61B5/026 A61B5/14542 A61B5/14551		
优先权	61/945557 2014-02-27 US		
其他公开文献	US10258241		
外部链接	Espacenet USPTO		

摘要(译)

在一个实施例中，一种用于光声成像的装置包括：第一接触区域，适于将第一压力施加到受试者的成像体积的表面；以及第二接触区域，适于向表面施加第二压力。第二接触区域被配置为通过限制相对于第一接触区域的流动来提供从成像体积减少的血液出口。提供光能输出端口以照射成像体积，以从成像体积中的血液的吸收光能产生光声信号。光声信号由一个或多个超声换能器检测并由处理器处理以产生体积的图像。通过处理检测到的光声信号产生的图像在显示器上输出。

