



US010271736B2

(12) **United States Patent**
O'Neill

(10) **Patent No.: US 10,271,736 B2**
(45) **Date of Patent: Apr. 30, 2019**

(54) **LOW COST MAGNETIC RESONANCE SAFE PROBE FOR TEMPERATURE MEASUREMENT**

(58) **Field of Classification Search**
CPC A61B 5/01
(Continued)

(71) Applicant: **KONINKLIJKE PHILIPS N.V.**,
Eindhoven (NL)

(56) **References Cited**

(72) Inventor: **Francis Patrick O'Neill**, Kissimee, FL
(US)

U.S. PATENT DOCUMENTS

(73) Assignee: **KONINKLIJKE PHILIPS N.V.**,
Eindhoven (NL)

4,531,842 A 7/1985 Schonberger
5,653,239 A 8/1997 Pompei
(Continued)

(*) Notice: Subject to any disclaimer, the term of this patent is extended or adjusted under 35 U.S.C. 154(b) by 401 days.

FOREIGN PATENT DOCUMENTS

(21) Appl. No.: **15/302,529**

EP 0213239 3/1987
EP 0498996 8/1992
(Continued)

(22) PCT Filed: **Mar. 31, 2015**

OTHER PUBLICATIONS

(86) PCT No.: **PCT/IB2015/052351**
§ 371 (c)(1),
(2) Date: **Oct. 7, 2016**

Hofman, et al., "Transepophageal Cardiac Pacing During Magnetic Resonance Imaging: Feasibility and Safety Considerations", *Magnetic Resonance in Medicine*, vol. 35. No. 3, Mar. 1, 1996.

(87) PCT Pub. No.: **WO2015/159171**
PCT Pub. Date: **Oct. 22, 2015**

(Continued)

Primary Examiner — Louis M Arana

(65) **Prior Publication Data**

US 2017/0027449 A1 Feb. 2, 2017

Related U.S. Application Data

(57) **ABSTRACT**

(60) Provisional application No. 61/979,539, filed on Apr. 15, 2014.

A temperature measurement probe (130) for use in a magnetic resonance environment, includes an elongated substrate (202), at least one highly resistive, electrically conductive traces (200, 200a, 200b, 200a', 200b') one printed at least one thermistor (204) disposed on the substrate and electrically connected with the trace. The thermistor is configured to be placed in thermal communication with a patient in the magnetic resonance environment. In some embodiments, the printed trace may be carbon-based, silicone based, or may be a doped semiconductor material.

(51) **Int. Cl.**
G01V 3/00 (2006.01)
A61B 5/01 (2006.01)
(Continued)

(52) **U.S. Cl.**
CPC **A61B 5/01** (2013.01); **A61B 5/0008** (2013.01); **A61B 5/055** (2013.01); **G01K 7/24** (2013.01);
(Continued)

15 Claims, 5 Drawing Sheets

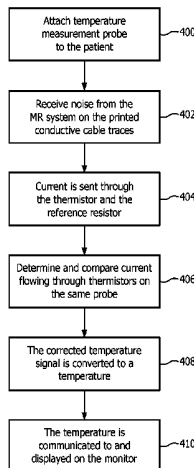

- | | | | | | | |
|------|-------------------|-----------|------------------|---------|------------------|--------------|
| (51) | Int. Cl. | | 2006/0247509 A1 | 11/2006 | Tuccillo | |
| | A61B 5/00 | (2006.01) | 2010/0219085 A1* | 9/2010 | Oviatt, Jr. | A61B 5/14532 |
| | A61B 5/055 | (2006.01) | | | | 205/782 |
| | G01R 33/28 | (2006.01) | 2010/0244833 A1 | 9/2010 | Sakakura | |
| | G01R 33/31 | (2006.01) | 2011/0249699 A1 | 10/2011 | Bieberich | |
| | G01K 7/24 | (2006.01) | 2015/0141792 A1 | 5/2015 | O'Neill | |
| | | | 2018/0064348 A1* | 3/2018 | Tsuchimoto | A61B 5/01 |
| | | | 2018/0206729 A1* | 7/2018 | Wang | A61B 5/01 |

- (52) **U.S. Cl.**
 CPC **G01R 33/288** (2013.01); **G01R 33/31**
 (2013.01); **A61B 2562/0271** (2013.01)

FOREIGN PATENT DOCUMENTS

- (58) **Field of Classification Search**
 USPC 324/314, 318, 322
 See application file for complete search history.

JP	6249716	9/1994
JP	2004-219098	8/2004
WO	2013175457	11/2013

- (56) **References Cited**

OTHER PUBLICATIONS

U.S. PATENT DOCUMENTS

5,730,134 A	3/1998	Dumoulin
6,270,463 B1	8/2001	Morris
8,801,272 B2	8/2014	Bieberich
2006/0241392 A1	10/2006	Feinstein

Weiss, et al., "Evaluation of a novel MR-RF ablation catheter with full clinical functionality", Proceedings of the International Society for Magnetic Resonance in Medicine, May 2011.

* cited by examiner

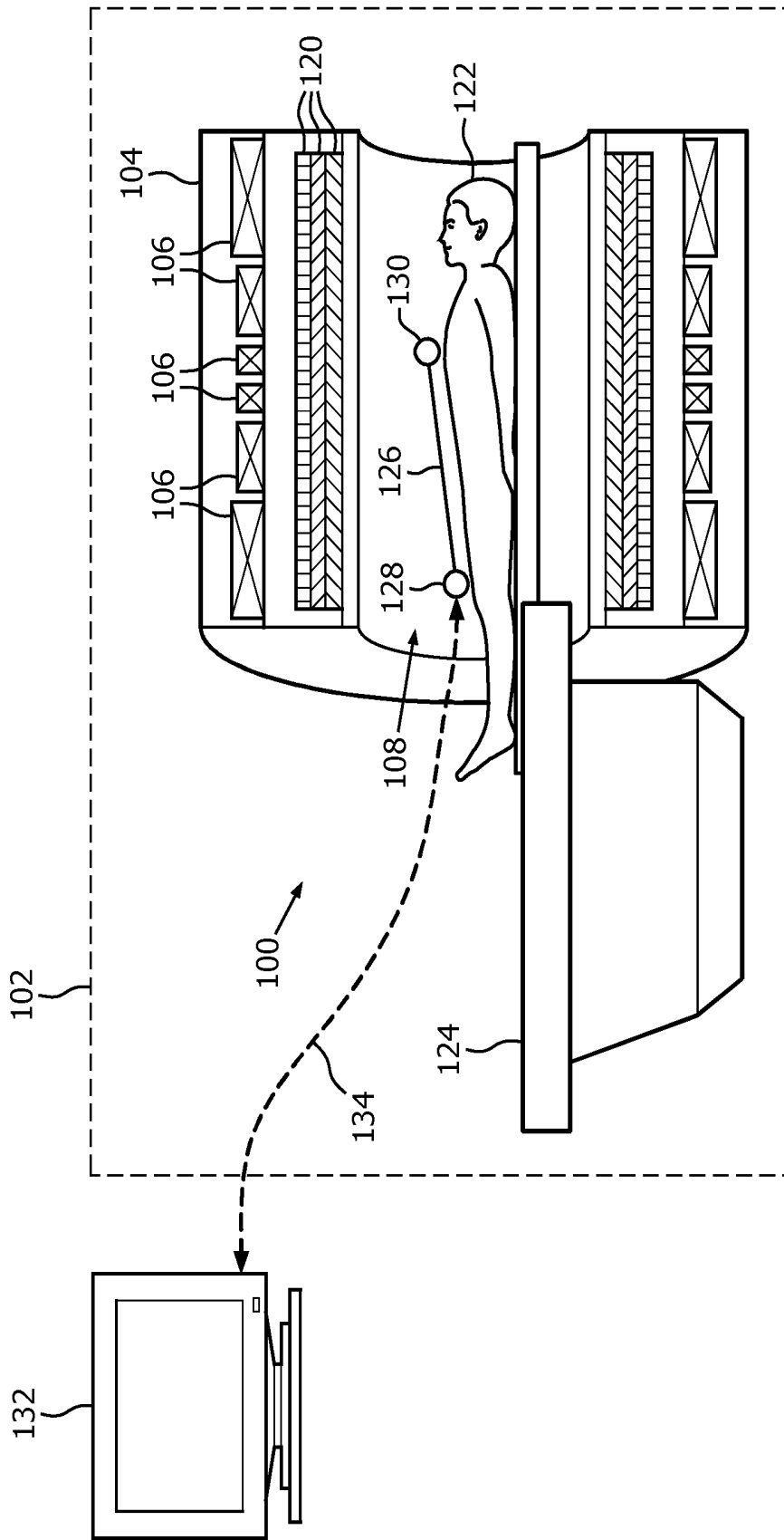

FIG. 1

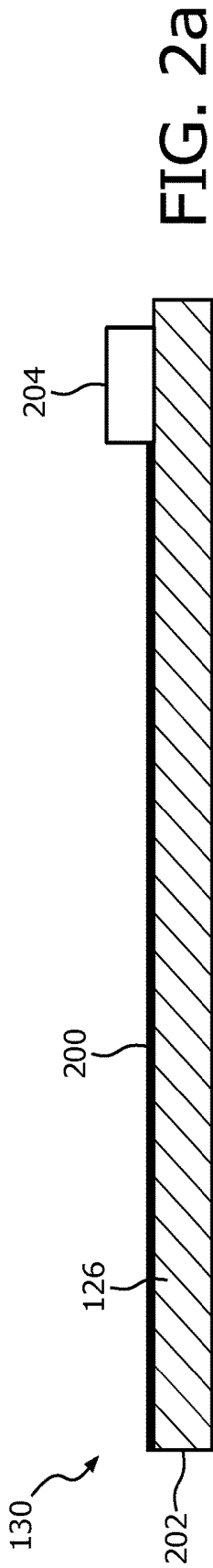

FIG. 2a

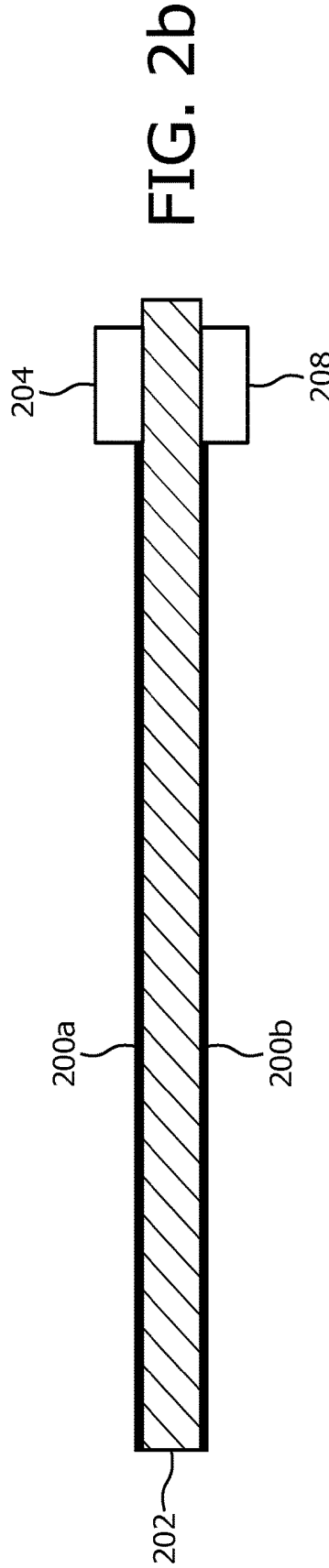

FIG. 2b

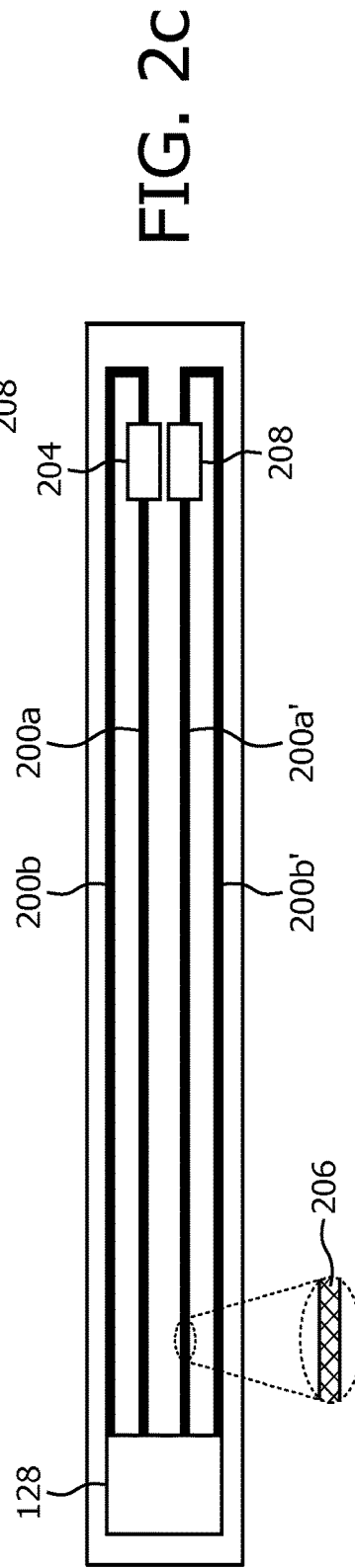

FIG. 2c

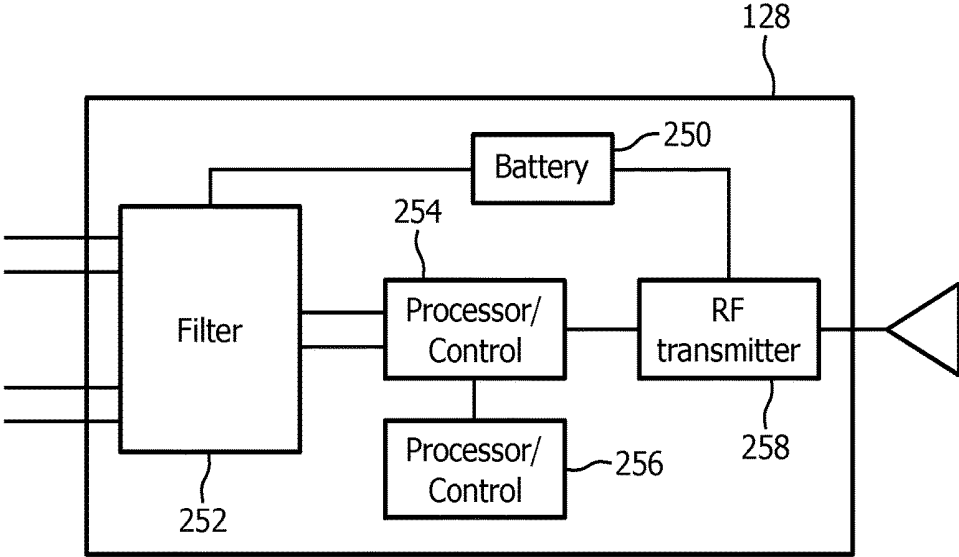

FIG. 2d

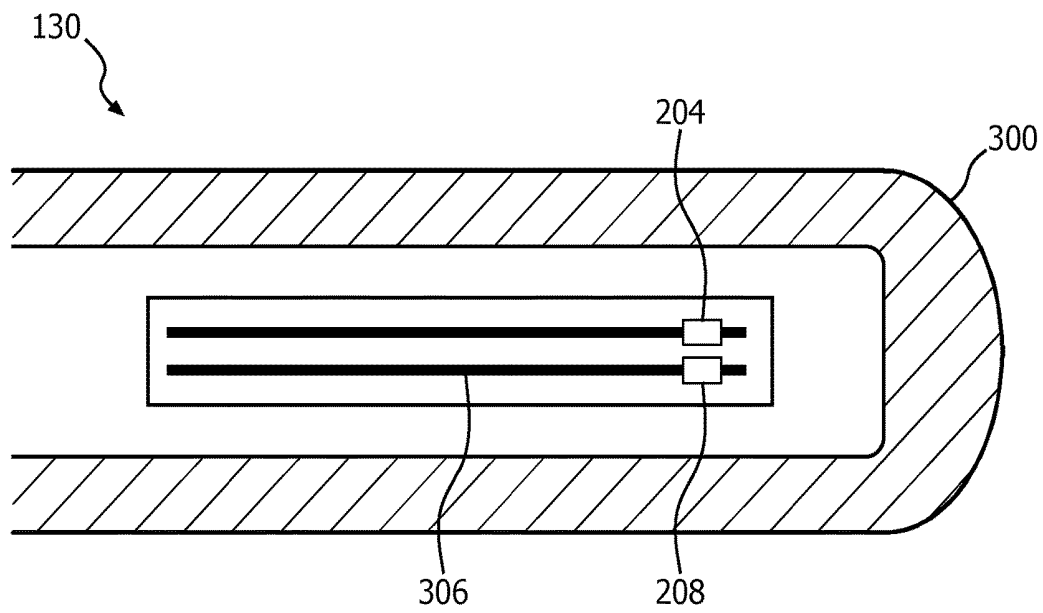

FIG. 3

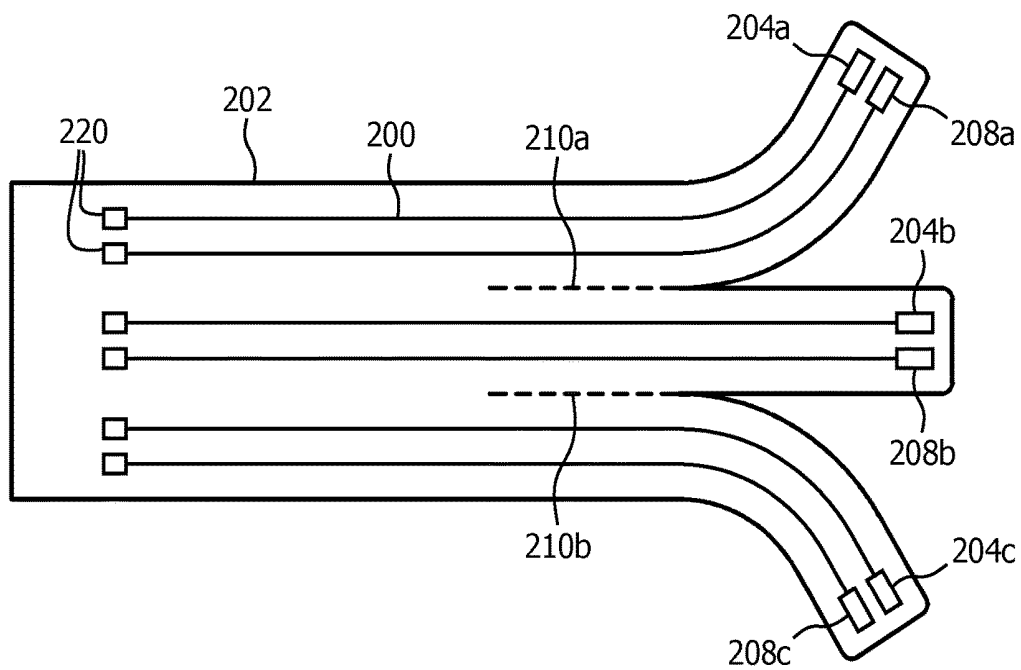

FIG. 4

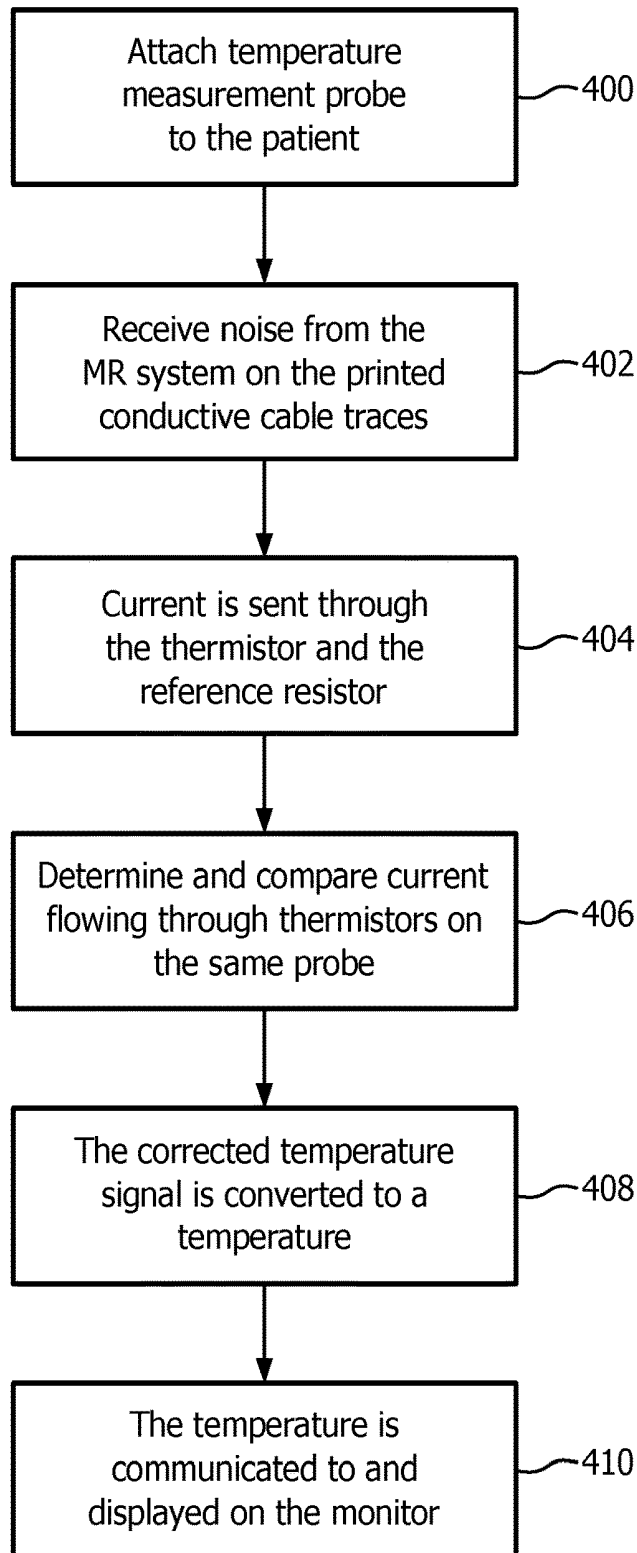

FIG. 5

**LOW COST MAGNETIC RESONANCE SAFE
PROBE FOR TEMPERATURE
MEASUREMENT**

CROSS REFERENCE TO RELATED
APPLICATIONS

This application is the U.S. National Phase application under 35 U.S.C. § 371 of International Application No. PCT/IB2015/052351, filed Mar. 31, 2015, published as WO 2015/159171 on Oct. 22, 2015, which claims the benefit of U.S. Provisional Patent Application No. 61/979,539 filed Apr. 15, 2014. These applications are hereby incorporated by reference herein.

The following relates generally to a temperature monitoring apparatus and method that can operate in a magnetic resonance (MR) environment. It finds particular application in conjunction with low cost, high resistance non-magnetic printed traces, which operate near a magnetic resonance imaging scanner, and will be described with particular reference thereto. However, it will be understood that it also finds application in other usage scenarios and is not necessarily limited to the aforementioned application.

Temperature monitoring devices need to be used in MR environments to monitor the condition of the patient. Current accepted methods include the use of a fiber optic probe. A fiber optic cable is connected to the sensing element on the patient, and to the patient monitoring device. However, these fiber optic cables are expensive, can be mechanically delicate, and may suffer from errors as a result of atomic level changes in the sensor material due to strong magnetic fields. The use of a standard thermistor in an MR environment would require the use of a distributed or discrete high-resistance cable to connect the sensor to the monitor to overcome the RF heating effects and burn hazards associated with the MR environment. These high resistance cables are expensive and do not fully eliminate the burn hazard to patients. In addition, these cables are difficult to manufacture, are susceptible to triboelectric effects, suffer from inductive pickup, excessive parasitic capacitance, and are hyper sensitive to patient movement. For example, ferromagnetic content used in the construction of the temperature-monitoring device may cause the cable to be drawn into the MRI scanner causing damage to the patients, users, or causing the equipment to act as a projectile. Additionally, the radio frequency field produced by the MRI scanner may generate currents in a standard cable using a standard thermistor, or cause “hot-spots” that may increase surface temperatures enough to exceed those allowed by regulatory standards and pose discomfort or a burn hazard to the patient. Further, the MRI gradient interference from the MR scanner can also induce currents on standard cables and thermistors and on the connection points producing an additive interference waveform component that potentially gives a false temperature reading.

The present application discloses a new and improved temperature-monitoring device for use in an MR environment, which addresses the above referred issues, and others.

According to one aspect, a temperature measurement probe for use in a magnetic resonance environment, is disclosed. The printed conductor includes an elongated substrate, at least one highly resistance, electrically conductive trace printed on the substrate, and at least one thermistor disposed on the substrate and electrically connected with the trace, the thermistors configured to be placed in thermal communication with a patient in the magnetic resonance environment.

According to another aspect, a magnetic resonance system is disclosed. The system includes a magnetic resonance scanner and a temperature measurement probe as set forth in the proceeding paragraphs, the temperature measurement probe being disposed in an examination region of the magnetic resonance scanner.

According to another aspect, a method for monitoring patient temperature readings during an MRI is disclosed. The method includes printing a highly resistive, electrically conductive trace on an elongated substrate and electrically connecting at least one thermistor disposed on the substrate with the trace.

Another advantage resides in the elimination of ferromagnetic content.

Another advantage resides in the reduction of patient burn risks.

Another advantage resides in ability to disinfect the thermistor probe.

Another advantage resides in improved patient care.

Still further advantages will be appreciated to those of ordinary skill in the art upon reading and understanding the following detailed description.

The invention may take form in various components and arrangements of components, and in various steps and arrangement of steps. The drawings are only for purposes of illustrating the preferred embodiments and are not to be construed as limiting the invention.

FIG. 1 diagrammatically shows a magnetic resonance (MR) system with a temperature monitoring apparatus operating inside the MR scanner.

FIG. 2a is a cross-sectional view diagrammatically showing a substrate with a printed trace with applicable thermistors.

FIG. 2b is a side view in partial section diagrammatically showing a temperature sensing thermistor and a reference element on opposite faces of a substrate.

FIG. 2c is a top view diagrammatically showing two printed traces with a temperature sensing thermistor and reference element on a common surface of a substrate.

FIG. 2d is illustrative of a circuit for converting the thermistor output to temperature.

FIG. 3 diagrammatically shows a printed trace and thermistor temperature measurement device in a protective housing or catheter shown in section.

FIG. 4 diagrammatically shows a plurality of temperature sensors disposed on a common substrate with tear lines in the elongated substrate that enable placement of the sensors at a plurality of locations.

FIG. 5 illustrates a method for monitoring patient temperature readings during a MRI using the printed conductor disclosed herein.

With reference to FIG. 1, a magnetic resonance environment includes a magnetic resonance (MR) scanner **100** disposed in a radio frequency isolation room **102** (diagrammatically indicated by a dashed box surrounding the MR scanner **100**). For example, a wire mesh or foil define a Faraday cage or other radio frequency screening structures embedded in or disposed on the walls, ceiling, and floor of the MR room containing the MR scanner **100**. The MR scanner **100** is shown in diagrammatic side-sectional view in FIG. 1, and includes a housing **104** containing a main magnet windings **106** (typically superconducting and contained in suitable cryogenic containment, not shown, although a resistive magnet windings are also contemplated) that generate a static (B_0) magnetic field in a bore **108** or other examination region. The housing **104** also contains magnetic field gradient coils **120** for superimposing mag-

netic field gradients on the static (B_0) magnetic field. Such gradients have numerous applications as is known in the art, such as spatially encoding magnetic resonance, spoiling magnetic resonance, and so forth. An imaging subject, such as an illustrative patient **122**, or an animal (for veterinary imaging applications), or so forth is loaded into the examination region (inside the bore **108** in the illustrative case) via a suitable couch **124** or other patient support/transport apparatus. The MR scanner may include numerous additional components known in the art, which are not shown for simplicity, such as magnetic field shims, a whole body radio frequency (RF) coil disposed in the housing **104**, and so forth. The MR scanner also typically includes numerous auxiliary or ancillary components again not shown for simplicity, such as power supplies for the main magnet **106** and the magnetic field gradient coils **120**, local RF coils (e.g. surface coils, a head coil or limb coil, or so forth), RF transmitter and RF reception hardware, and various control and image reconstruction systems, by way of some examples. Moreover, it is to be understood that the illustrative MR scanner **100**, which is a horizontal bore type scanner, is merely an illustrative example and that more generally the disclosed MR safe cables and electrodes are suitably employed in conjunction with any type of MR scanner (e.g., a vertical bore scanner, open-bore scanner, or so forth).

In operation, the main magnet **106** operates to generate a static B_0 magnetic field in the examination region **108**. RF pulses are generated by the RF system (including for example a transmitter and one or more RF coils disposed in the bore or a whole-body RF coil in the housing **104**) at the Larmor frequency (i.e., magnetic resonance frequency) for the species to be excited (usually protons, although other species may be excited, e.g. in MR spectroscopy or multinuclear MR imaging applications). These pulses excite nuclear magnetic resonance (NMR) in the target species (e.g., protons) in the subject **122**, which are detected by a suitable RF detection system (e.g., a magnetic resonance coil or coils and suitable receiver electronics). Magnetic field gradients are typically applied by the gradient coils **120** before or during excitation, during a delay period (e.g., time to echo or TE) period prior to readout, and/or during readout in order to spatially encode the NMR signals. An image reconstruction processor applies a suitable reconstruction algorithm comporting with the chosen spatial encoding in order to generate a magnetic resonance image, which may then be displayed, rendered, fused or contrasted with other MR images and/or images from other modalities, or otherwise utilized.

With continuing reference to FIG. **1** and further reference to FIGS. **2a-2c**, as part of or ancillary to the MR procedure, temperature measurements are acquired using a temperature measurement probe **130**. In illustrative FIG. **1**, a printed conductor for temperature measurement probe **130** is displayed on the patient **122** and in connection with a monitor **132** (located outside or optionally inside) the MR chamber **102**. The temperature-measurement probe **130** may have sufficiently low power consumption that the temperature function may be integrated into a battery powered control and processing circuit **128** that communicates wirelessly **134** (showing as a dashed line from the battery powered control and processing circuit to the monitor) with the monitor **132**. The temperature measurement probe **130** with a conductive trace printed cable **126** and the battery powered control and processing circuit **128** may record surface or invasive temperature measurements of the patient **122**. The conductive

trace printed cable **126** may further be integrated into other cables particularly for surface use.

Further reference to FIGS. **2a-2c** a controlled resistance printed electrical trace or conductive trace, **200** is printed on a flexible, MR neutral substrate **202** to form the planar lead cable **126** between a thermistor **204** on the patient **122** and the sensing monitor **128**. The substrate **202** may be any flexible magnetic resonance inert planar material such as a polymer resin-based film or Mylar. The substrate **202** material is selected so that Proton emissions do not degrade the MR image. In various embodiments, the conductive trace **200** is formed of carbon-based ink. The conductive trace **200** may optionally be silicon based or may be made from a doped semiconductor material. Further, the printed conductive traces **200** and thermistors **204** should be non-ferromagnetic to inhibit distortion of magnetic fields and to inhibit the magnetic field and gradient from adversely affecting the probe.

With continuing reference to FIG. **2a-2c**, the conductive trace **200** is configured to inhibit eddy current from forming in the trace and causing resistive heating. The traces can be of high resistance and can include slots or other constructs that inhibit eddy current loops. Connection probes are printed or applied at the thermistor end of the trace and a control and processing circuit to facilitate connection to the thermistor **204** and the control and processing circuit **128**. In other embodiments, the conductive printed trace may be solid or may contain features such as cross-hatching to inhibit eddy current generation in the conductive printed trace. The cross-hatching **206** in the trace **204** improves functional performance by reducing the induction of interference currents in the electrode and resistive traces from the RF and gradient magnetic fields. By printing the conductive trace and the thermistor lead connections of the temperature probe **130**, repeatability, and reproducibility of the lead-wire characteristics, routing is facilitated.

The thermistor **204** is a high resistance thermistor preferably on the order of 10,000 k Ohms, tuned to respond linearly in the range of human body temperatures with the low cost. The printed conductive trace **200** resistance can be in the order of 8-10 k Ohms per foot, which may be achieved by printing with a conductive ink in the order of 10 ohms per square. The printed conductive trace resistance can be laser trimmed to achieve a desired target resistance to narrow the traces or by forming eddy current inhibiting longitudinal slots. The thermistor **204** may be attached by surface mount leads or attached used conductive leads.

In the embodiment, illustrated in FIG. **2b-c**, temperature sensitive thermistor **204** and a reference resistor or thermistor **208** are connected in loops with printed input and output traces **200a**, **200b**, which are printed on opposite faces of the substrate **202**. One of the thermistors is applied to the patient and the reference element is thermally isolated from the patient or is selected to have stable resistance across the temperature range of interest. In this manner, the temperature sensing element signal is indicative of temperature with RF field induced currents to and the reference element signal is indicative of RF field induced currents which allow for elimination of RF field induced currents by using a common mode filter.

In other embodiments, the resistance may be evenly or unevenly distributed along the printed conductive cable trace **200**. Uneven distribution can be achieved by varying the width and or thickness of the printing pattern. Notch or low pass filed integrated circuit components, antenna cir-

cuits, power supplies, sensors (piezo, MEMS, accelerometers) may be optionally incorporated into the printed conductive cable trace **200**.

In another embodiment illustrated in FIG. 2c, a circuit is formed by the temperature sensing thermistor **204**, and the reference elements **208**, e.g. a reference resistor, two input traces **200a**, **200b**, two return traces **200b**, **200b'** connected to the two input traces **200a**, **200b** (connection not shown) disposed on a common face of the substrate **202** and the processing and control circuit **128**.

With reference to FIG. 2d, the resistance of a thermistor changes with temperature. The process and controlled circuit **128** translates the currents through or voltages across the thermistors into temperature values for transmission to the monitor **132**. The circuit includes a battery **250** or other power supply outside of the MR environment. A filter **252** corrects for noise in the thermistor signals, e.g., by subtracting the noise signal from the reference element **200** from the noisy temperature signal from the temperature measuring thermistor **204**. A control or processor **254** converts the temperature into a temperature, e.g. using a look-up table stored in an EPROM **256**. The look-up table can further compensate for variations from one temperature sensor to the next. An RF transmitter **258** transmits the determined temperature value to an RF receiver connected with the monitor **132**. It is to be appreciated that the filtering and the conversion to temperature can, in full or in part, be performed at the monitor **132**.

In various embodiments, the printed conductive traces **200** are suitably formed of carbon-based ink with specific electrical resistance applied to the planar flexible substrate with predefined electrical resistance applied to the planar flexible substrate **202** to achieve the desired resistance and thermal characteristics. The printed conductive traces **200** may be applied by any reproductive method such as by screen-printing. The printed conductive traces **200** may be solid or may contain features such as hatching, longitudinal slots, or the like.

With reference to FIG. 3, a side sectional view of the temperature measurement probe is displayed. A protective jacket **300** covers the probe and can provide electrical insulation and protection. The protective layer **300** is preferably electrically insulating compared with the material of the printed conductive traces **200**, and non-ferromagnetic and MR compatible. For one-time use probes the protective layer is ideally a material that is low cost and sterilisable. The sterilisable protective jacket allows the probe to be inserted into the patient during an MR to provide internal temperature measurement to further protect from injury to the patient. The protective layer **300** can have a foam insulating layer to insulate the circuit from induction of interference currents in the electrode and resistive traces from static and gradient magnetic fields. Again, a reference resistor or thermistor **208** may be added to create the common mode signal for subtraction from the patient temperature measuring thermistor **204** to compensate for the common mode. The housing **300** can be part of a catheter that is configured for other functions.

With reference to FIG. 4, the temperature measurement probe **130** may include a plurality of printed traces on one face of the elongated substrate **202**, a plurality of return traces (not shown) on an opposite face, a plurality of thermistors **204a**, **204b**, **204c**, and a plurality of reference elements **208a**, **208b**, **208c**. In some embodiments, connection pads **220**, e.g. silver chloride, are printed on the traces to facilitate connection to the thermistor, the reference element, and the circuit. Tear lines **210a**, **210b**, are defined

in the elongated substrate **202**. The tear lines **210a**, **210b** in the substrate **202** allow the printed traces **200a**, **200b**, **200c** to be separable to accommodate multi-site sensing on various patient body types.

With reference to FIG. 5, initially, the substrate is cut to size and the conductive traces and the connection pads are printed on the substrate. The thermistor **204**, the reference element **208**, and the circuit **128** are connected to the connection pads. To avoid burns or other injury to patient during an MR, the temperature of the probe is monitored during operation. In a step **400**, the printed conductor for temperature measurement probe **130** is attached to the patient **122**. The printed conductor **126** of temperature measurement probe **130** is connected to a patient monitor **132** either wirelessly **134** or through a wired connection. Upon activation of the MR system **100**, in a step **402**, the probe receives a noise on the printed trace **200** created by the MR system **100**. The probe **130** preferably contains a reference element **208**, e.g. a reference resistor or a reference thermistor. In a step **404**, a current is sent through the thermistor **204** and the reference element **208**. In a step **406**, the currents flowing through the thermistor **204** and the reference element **208** are determined and compared. The current through the thermistor is indicative of the MR induced noise and temperature. The current through the reference resistor is indicative of MR induced noise. The comparison of the current flowing through the reference element **208** and the thermistor **204** allows the current or signal from the thermistor **204** to be corrected for noise. In a step **408**, the corrected temperature signal is converted to a temperature, e.g. with a look-up table. In a step **410**, the temperature is communicated to and displayed on the monitor **132**, e.g. by RF transmission lines.

The invention has been described with reference to the preferred embodiments. Obviously, modifications and alterations will occur to others upon reading and understanding the proceeding detailed description. It is intended that the invention be construed as including all such modifications and alterations insofar as they come within the scope of the appended claims or the equivalents thereof.

The invention claimed is:

1. A temperature measurement probe for use in a magnetic resonance environment comprising:
 - an elongated substrate;
 - a plurality of resistive electrically conductive traces printed on the substrate;
 - at least one thermistor disposed on the substrate and electrically connected with at least one of the traces, the thermistor configured to be placed in thermal communication with a patient in the magnetic resonance environment;
 - at least one reference element connected with one of the resistive traces, wherein the at least one reference element includes a thermistor which is thermally isolated from the patient or a resistor; and
 - a processor and control circuit electrically connected with the traces, the processor and control circuit being configured to subtractively combine a temperature signal with MR related noise and an MR related noise signal from the reference element.
2. The temperature measurement probe according to claim 1, wherein the traces are screen printed with a resistive, conductive ink.
3. The temperature measurement probe according to claim 1, wherein the traces are carbon-based.

4. The temperature measurement probe according to claim 1, wherein the traces include doped semiconductor material.

5. The temperature measurement probe according to claim 1, wherein the at least one highly resistive, electrically conductive trace resistance is on in the order of 26-33 k Ohms per meter.

6. The temperature measurement probe according to claim 1, wherein the traces are etched in a cross-hatch.

7. The temperature measurement probe according to claim 1, wherein the traces include an input trace which provides electric power to the thermistor and a return trace.

8. The temperature measurement probe according to claim 7, wherein the wherein the input and return traces are disposed on opposite faces of the substrate.

9. The temperature measurement probe according to claim 7, wherein the input and return traces are disposed on a common face of the substrate.

10. The temperature measurement probe according to claim 1, further including:

a plurality of thermistors disposed on the plurality of printed traces;

tear lines in the elongated substrate such that the printed traces are separable to accommodate positioning the plurality of thermistors for multi-site sensing on various patient body shapes.

11. The temperature measurement probe according to claim 1, further including:

a sterilisable protective jacket.

12. The temperature measurement probe according to the claim 1, further including:

connection pads formed on the traces configured for electrical connection with the thermistor.

13. A magnetic resonance system, comprising: a magnetic resonance scanner; and

the temperature measurement probe according to claim 1, wherein the thermistor and at least a portion of the substrate and the at least one trace is disposed in an examination region of the magnetic resonance scanner.

14. A method for monitoring temperature in a magnetic resonance environment comprising:

printing a plurality of resistive, electrically conductive traces on an elongated substrate;

electrically connect at least one patient temperature measuring thermistor to at least one of the traces;

connecting a reference element for sensing a common mode signal for subtraction from a signal from the patient temperature measuring thermistor to one of the traces, wherein the signal on trace from thermistor includes noise and temperature information, and the signal on trace from reference element includes the noise;

applying the thermistor and the reference element to the patient;

processing the signals from the thermistor and the reference element to correct the thermistor signal from the noise; and

convert corrected thermistor signal to a temperature value.

15. The method according to claim 14, further including: conveying the temperature value to a monitor and displaying the temperature value on the monitor.

* * * * *

专利名称(译)	用于温度测量的低成本磁共振安全探头		
公开(公告)号	US10271736	公开(公告)日	2019-04-30
申请号	US15/302529	申请日	2015-03-31
[标]申请(专利权)人(译)	皇家飞利浦电子股份有限公司		
申请(专利权)人(译)	皇家飞利浦N.V.		
当前申请(专利权)人(译)	皇家飞利浦N.V.		
[标]发明人	ONEILL FRANCIS PATRICK		
发明人	O'NEILL, FRANCIS PATRICK		
IPC分类号	G01V3/00 A61B5/00 A61B5/01 A61B5/055 G01K7/24 G01R33/31 G01R33/28		
CPC分类号	A61B5/01 A61B5/0008 A61B5/055 G01R33/288 G01R33/31 G01K7/24 A61B2562/0271		
优先权	61/979539 2014-04-15 US		
其他公开文献	US20170027449A1		
外部链接	Espacenet		

摘要(译)

用于磁共振环境的温度测量探头 (130) 包括细长基板 (202) , 至少一个高电阻导电迹线 (200,200 200 b 200 a' , 200 b) 一个印刷的至少一个热敏电阻 (204) 设置在基板上并与迹线电连接。热敏电阻配置成在磁共振环境中与患者热连通。在一些实施例中, 印刷迹线可以是碳基的, 基于硅树脂的, 或者可以是掺杂的半导体材料。

