



US009756403B2

(12) **United States Patent**  
**Proud**

(10) **Patent No.:** **US 9,756,403 B2**  
(45) **Date of Patent:** **\*Sep. 5, 2017**

(54) **MONITORING DEVICE WITH SELECTABLE WIRELESS COMMUNICATION**

(71) Applicant: **Hello Inc.**, San Francisco, CA (US)  
(72) Inventor: **James Proud**, San Francisco, CA (US)  
(73) Assignee: **Hello Inc.**, San Francisco, CA (US)

(\* ) Notice: Subject to any disclaimer, the term of this patent is extended or adjusted under 35 U.S.C. 154(b) by 0 days.

This patent is subject to a terminal disclaimer.

(21) Appl. No.: **15/242,540**  
(22) Filed: **Aug. 21, 2016**  
(65) **Prior Publication Data**  
US 2016/0360300 A1 Dec. 8, 2016

**Related U.S. Application Data**

(63) Continuation of application No. 13/955,777, filed on Jul. 31, 2013, now Pat. No. 9,430,938, which is a (Continued)

(51) **Int. Cl.**  
**H04Q 9/00** (2006.01)  
**G01D 4/00** (2006.01)  
(Continued)

(52) **U.S. Cl.**  
CPC ..... **H04Q 9/00** (2013.01); **A61B 5/0022** (2013.01); **A61B 5/0024** (2013.01);  
(Continued)

(58) **Field of Classification Search**  
None  
See application file for complete search history.

(56) **References Cited**

U.S. PATENT DOCUMENTS

3,127,363 A 3/1964 Nitzsche et al.  
3,715,334 A 2/1973 Karstedt  
(Continued)

FOREIGN PATENT DOCUMENTS

DE 3839900 5/1990  
EP 0183553 6/1986  
(Continued)

OTHER PUBLICATIONS

Davida, G.I., et al., "On enabling secure applications through off-line biometric identification", Proceedings of the IEEE Symposium on Security and Privacy (May 1998).  
(Continued)

*Primary Examiner* — Kristy A Haupt  
(74) *Attorney, Agent, or Firm* — Paul Davis

(57) **ABSTRACT**

One or more sensors are coupled to a monitoring device which has a unique user ID. The one or more sensors acquire user information selected from of at least one of, a user's activities, behaviors and habit information. ID circuitry including ID storage, a communication system that reads and transmits the unique ID from an ID storage, a power source and a pathway system to route signals through the circuitry is at the monitoring device. A multi-protocol wireless controller coupled to one or more wireless interfaces is at the monitoring device and characterizes available networks to determine current network information. A wireless connectivity assistant is at the monitoring device and selects one of the available networks based on the current network information and at least one of user preferences, application requirements and system information. A telemetry system is in communication with the monitoring device.

**22 Claims, 23 Drawing Sheets**

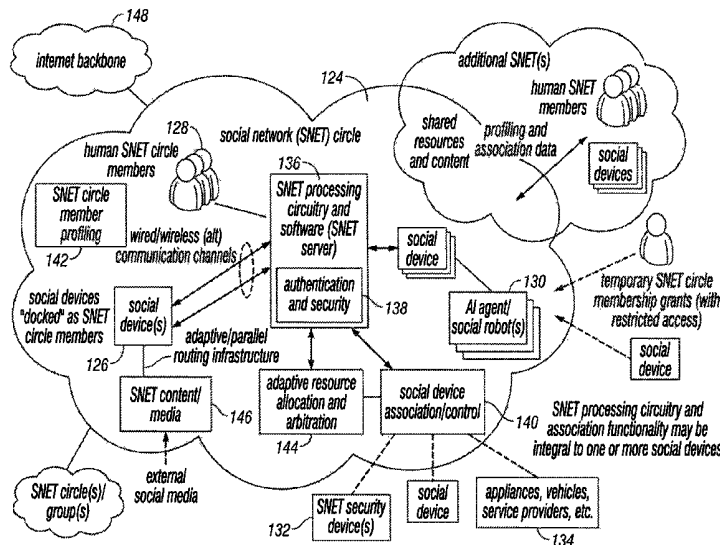

**Related U.S. Application Data**

continuation-in-part of application No. 13/923,909, filed on Jun. 21, 2013, now Pat. No. 9,407,097, and a continuation-in-part of application No. 13/923,637, filed on Jun. 21, 2013, now Pat. No. 8,810,430, and a continuation-in-part of application No. 13/923,614, filed on Jun. 21, 2013, now Pat. No. 8,850,421, and a continuation-in-part of application No. 13/923,809, filed on Jun. 21, 2013, now Pat. No. 9,425,627, and a continuation-in-part of application No. 13/923,750, filed on Jun. 21, 2013, now Pat. No. 9,438,044, and a continuation-in-part of application No. 13/923,583, filed on Jun. 21, 2013, now abandoned, and a continuation-in-part of application No. 13/923,560, filed on Jun. 21, 2013, now Pat. No. 8,803,366, and a continuation-in-part of application No. 13/923,543, filed on Jun. 21, 2013, and a continuation-in-part of application No. 13/923,937, filed on Jun. 21, 2013.

(60) Provisional application No. 61/772,265, filed on Mar. 4, 2013, provisional application No. 61/823,502, filed on May 15, 2013, provisional application No. 61/812,083, filed on Apr. 15, 2013.

(51) **Int. Cl.**

- G08C 17/02** (2006.01)
- H02J 50/80** (2016.01)
- H02J 7/02** (2016.01)
- H02J 17/00** (2006.01)
- A61B 5/0205** (2006.01)
- H04L 29/08** (2006.01)
- H04W 4/00** (2009.01)
- H04W 4/20** (2009.01)
- A61B 90/90** (2016.01)
- A61B 90/98** (2016.01)
- H02J 7/00** (2006.01)
- A61B 5/00** (2006.01)
- A61B 5/11** (2006.01)

(52) **U.S. Cl.**

CPC ..... **A61B 5/02055** (2013.01); **A61B 90/90** (2016.02); **A61B 90/98** (2016.02); **G01D 4/002** (2013.01); **G08C 17/02** (2013.01); **H02J 7/025** (2013.01); **H02J 17/00** (2013.01); **H02J 50/80** (2016.02); **H04L 67/02** (2013.01); **H04L 67/125** (2013.01); **H04W 4/005** (2013.01); **H04W 4/008** (2013.01); **H04W 4/206** (2013.01); **A61B 5/1112** (2013.01); **A61B 5/1118** (2013.01); **A61B 5/443** (2013.01); **A61B 5/6831** (2013.01); **A61B 5/6898** (2013.01); **A61B 5/743** (2013.01); **A61B 2560/0214** (2013.01); **A61B 2562/0233** (2013.01); **A61B 2562/08** (2013.01); **H02J 2007/0096** (2013.01)

5,564,429	A	10/1996	Bornn et al.
5,576,054	A	11/1996	Brown
5,735,887	A	4/1998	Barreras, Sr. et al.
5,910,544	A	6/1999	Ozawa et al.
5,971,941	A	10/1999	Simons et al.
6,038,315	A	3/2000	Strait et al.
6,120,467	A	9/2000	Schallhom
6,200,289	B1	3/2001	Hochman et al.
6,221,012	B1	4/2001	Maschke et al.
6,323,846	B1	11/2001	Westerman et al.
6,416,471	B1	7/2002	Kumar et al.
6,440,067	B1	8/2002	DeLuca et al.
6,454,708	B1	9/2002	Ferguson et al.
6,570,557	B1	5/2003	Westerman et al.
6,580,356	B1	6/2003	Alt et al.
6,661,372	B1	12/2003	Girerd et al.
6,677,932	B1	1/2004	Westerman
6,893,396	B2	5/2005	Schulze et al.
7,099,850	B1	8/2006	Mann, II et al.
7,113,932	B2	9/2006	Tayebnejad et al.
7,248,894	B2	7/2007	Fujieda et al.
7,314,451	B2	1/2008	Halperin et al.
7,502,643	B2	3/2009	Farrington et al.
7,614,008	B2	11/2009	Ordning
7,616,110	B2	11/2009	Crump et al.
7,633,076	B2	12/2009	Huppi et al.
7,653,883	B2	1/2010	Hotelling et al.
7,657,849	B2	2/2010	Chaudhri et al.
7,663,607	B2	2/2010	Hotelling et al.
7,689,508	B2	3/2010	Davis et al.
7,720,855	B2	5/2010	Brown
7,733,224	B2	6/2010	Tran
7,844,914	B2	11/2010	Andre et al.
7,957,762	B2	6/2011	Herz et al.
7,959,567	B2	6/2011	Stivoric et al.
8,006,002	B2	8/2011	Kalayjian et al.
8,028,905	B2	10/2011	Holberg
8,033,996	B2	10/2011	Behar
8,044,363	B2	10/2011	Ales et al.
8,126,729	B2	2/2012	Dicks et al.
8,126,735	B2	2/2012	Dicks et al.
8,157,731	B2	4/2012	Teller et al.
8,180,591	B2	5/2012	Yuen et al.
8,204,786	B2	6/2012	LeBoeuf et al.
8,239,784	B2	8/2012	Hotelling et al.
8,251,903	B2	8/2012	LeBoeuf et al.
8,279,180	B2	10/2012	Hotelling et al.
8,328,718	B2	12/2012	Tran
8,352,211	B2	1/2013	Vock et al.
8,369,936	B2	2/2013	Farrington et al.
8,378,811	B2	2/2013	Crump et al.
8,381,135	B2	2/2013	Hotelling et al.
8,389,627	B2	3/2013	Rubinsztajn et al.
8,390,463	B2	3/2013	Munthe-Kaas et al.
8,398,538	B2	3/2013	Dothie
8,398,546	B2	3/2013	Pacione et al.
8,452,654	B1	5/2013	Wooters et al.
8,479,122	B2	7/2013	Hotelling et al.
8,508,356	B2	8/2013	Shuster et al.
8,587,426	B2	11/2013	Bloem
8,663,106	B2	3/2014	Stivoric et al.
8,882,684	B2	11/2014	Halperin
9,047,600	B2	6/2015	Zhou et al.
9,159,223	B2	10/2015	Proud
9,177,307	B2	11/2015	Ross et al.
9,204,806	B2	12/2015	Stivoric
9,326,364	B2	4/2016	Maeda
9,345,433	B1	5/2016	Shinozuka
9,360,351	B2	6/2016	Van Thienen
9,407,097	B2 *	8/2016	Proud ..... H01F 38/14
9,424,508	B2	8/2016	Proud
9,425,627	B2 *	8/2016	Proud ..... H01F 38/14
9,427,053	B2	8/2016	Proud
9,438,044	B2 *	9/2016	Proud ..... H01F 38/14
2002/0015024	A1	2/2002	Westerman et al.
2002/0109600	A1	8/2002	Mault et al.
2003/0023467	A1	1/2003	Moldovan
2003/0121033	A1	6/2003	Peev et al.
2003/0143113	A2	7/2003	Yuzhakov

(56) **References Cited**

U.S. PATENT DOCUMENTS

3,775,452	A	11/1973	Karstedt
3,813,364	A	5/1974	Selin et al.
3,814,730	A	6/1974	Karstedt
4,394,317	A	7/1983	McAfee et al.
4,603,152	A	7/1986	Laurin et al.
4,780,556	A	10/1988	Hata et al.
5,057,151	A	10/1991	Schuster et al.
5,187,657	A	2/1993	Forbes
5,319,363	A	6/1994	Welch et al.
5,348,008	A	9/1994	Bornn et al.

(56)

## References Cited

## U.S. PATENT DOCUMENTS

2004/0122685 A1 6/2004 Bunce  
 2004/0172290 A1 9/2004 Leven  
 2005/0113650 A1 5/2005 Pacione et al.  
 2005/0115561 A1 6/2005 Stahmann et al.  
 2005/0190059 A1 9/2005 Wehrenberg  
 2005/0245839 A1 11/2005 Stivoric et al.  
 2005/0250538 A1 11/2005 Narasimhan  
 2006/0017692 A1 1/2006 Wehrenberg et al.  
 2006/0026536 A1 2/2006 Hotelling et al.  
 2006/0030891 A1 2/2006 Saltzstein et al.  
 2006/0033724 A1 2/2006 Chaudhri et al.  
 2006/0066449 A1 3/2006 Johnson  
 2006/0098772 A1 5/2006 Reho et al.  
 2006/0136270 A1 6/2006 Morgan et al.  
 2006/0159645 A1 7/2006 Miller et al.  
 2006/0197753 A1 9/2006 Hotelling  
 2006/0208065 A1 9/2006 Mendelovich et al.  
 2007/0021979 A1 1/2007 Cosentino et al.  
 2007/0033069 A1 2/2007 Rao et al.  
 2007/0149862 A1 6/2007 Pipke  
 2007/0174633 A1 7/2007 Draper et al.  
 2007/0255564 A1 11/2007 Yee et al.  
 2008/0012701 A1 1/2008 Kass et al.  
 2008/0076969 A1 3/2008 Kraft et al.  
 2008/0146890 A1 6/2008 LeBoeuf et al.  
 2008/0275309 A1 11/2008 Stivoric et al.  
 2009/0023428 A1 1/2009 Behzad et al.  
 2009/0112247 A1 4/2009 Freeman et al.  
 2009/0119760 A1 5/2009 Hung et al.  
 2009/0182208 A1 7/2009 Cho et al.  
 2009/0203972 A1 8/2009 Heneghan et al.  
 2009/0240120 A1 9/2009 Mensinger et al.  
 2009/0255122 A1 10/2009 Azrielant  
 2009/0318773 A1 12/2009 Jung et al.  
 2010/0141042 A1 6/2010 Kesler et al.  
 2010/0153269 A1 6/2010 McCabe  
 2010/0191570 A1 7/2010 Michaud et al.  
 2010/0205091 A1 8/2010 Graziano et al.  
 2010/0234695 A1 9/2010 Morris  
 2010/0277003 A1 11/2010 Von Novak et al.  
 2011/0055132 A1 3/2011 Mahdian et al.  
 2011/0068935 A1 3/2011 Riley et al.  
 2011/0201306 A1 8/2011 Ali Al-Harbi et al.  
 2012/0016793 A1 1/2012 Peters et al.  
 2012/0068820 A1 3/2012 Mollicone et al.  
 2012/0133079 A1 5/2012 Sykes et al.  
 2012/0146795 A1 6/2012 Margon et al.  
 2012/0149996 A1 6/2012 Stivoric et al.  
 2012/0170521 A1 7/2012 Vogedes et al.  
 2012/0184876 A1 7/2012 Freeman et al.  
 2012/0194419 A1 8/2012 Osterhout et al.  
 2012/0196832 A1 8/2012 Luria  
 2012/0205373 A1 8/2012 Caldwell  
 2012/0225719 A1 9/2012 Nowozin et al.  
 2012/0226639 A1 9/2012 Burdick et al.  
 2012/0229270 A1 9/2012 Morley et al.  
 2012/0242501 A1 9/2012 Tran et al.  
 2012/0253485 A1 10/2012 Weast et al.  
 2012/0253489 A1 10/2012 Dugan  
 2012/0271712 A1 10/2012 Katzin et al.  
 2012/0290327 A1 11/2012 Hanlon et al.  
 2012/0290950 A1 11/2012 Rapaport et al.  
 2012/0330109 A1 12/2012 Tran

2013/0022659 A1 1/2013 Roberts  
 2013/0030711 A1 1/2013 Korhonen  
 2013/0030934 A1 1/2013 Bakshi et al.  
 2013/0102937 A1 4/2013 Ehrenreich et al.  
 2013/0127980 A1 5/2013 Haddick et al.  
 2013/0144190 A1 6/2013 Bruce et al.  
 2013/0175732 A1 7/2013 Lust et al.  
 2013/0326790 A1 12/2013 Cauwels et al.  
 2013/0338446 A1 12/2013 Van Vugt et al.  
 2014/0236922 A1 8/2014 Boyer et al.  
 2014/0266939 A1 9/2014 Baringer et al.

## FOREIGN PATENT DOCUMENTS

EP 0369255 5/1990  
 EP 0477681 4/1992  
 EP 0567253 10/1993  
 EP 0640663 3/1995  
 EP 0654497 5/1995  
 EP 1094091 4/2001  
 EP 1113042 7/2001  
 EP 1133936 9/2001  
 EP 1172414 1/2002  
 EP 1217042 6/2002  
 EP 1367534 12/2003  
 EP 1371004 12/2003  
 EP 1555297 7/2005  
 EP 1595676 11/2005  
 EP 1785454 5/2007  
 EP 1792944 6/2007  
 EP 1883798 2/2008  
 EP 2052352 4/2009  
 EP 2063555 5/2009  
 EP 2071423 6/2009  
 EP 2428774 3/2012  
 EP 2582116 4/2013  
 EP 2614945 7/2013  
 GB 1278798 6/1972  
 GB 1381933 1/1975  
 GB 2460890 12/2009  
 WO 8704449 7/1987  
 WO 9500992 1/1995  
 WO 9956922 11/1999  
 WO 02063555 8/2002  
 WO 2006127726 11/2006  
 WO 2008050951 5/2008  
 WO 2012170305 12/2012  
 WO 2013076676 5/2013  
 WO 2013081447 6/2013

## OTHER PUBLICATIONS

Juels, A., et al., "A Fuzzy Vault Scheme", Proceedings of the 2002 IEEE Symposium on Information Theory (Jun. 2002).  
 Juels, A., et al., "A fuzzy commitment scheme", Proc. 5th ACM Conference on Comp. and Commun. Security, pp. 28-36, (Sep. 2013).  
 Yang, S., et al., "Secure fuzzy vault fingerprint verification system", Asilomar Conf. on Signals, Systems and Comp., vol. 1, pp. 577-581 (Nov. 2004).  
 Uludag, U., et al., "Fuzzy fingerprint vault", Proc. Workshop: Biometrics: Challenges arising from theory to practice, pp. 13-16 (Aug. 2004).

\* cited by examiner

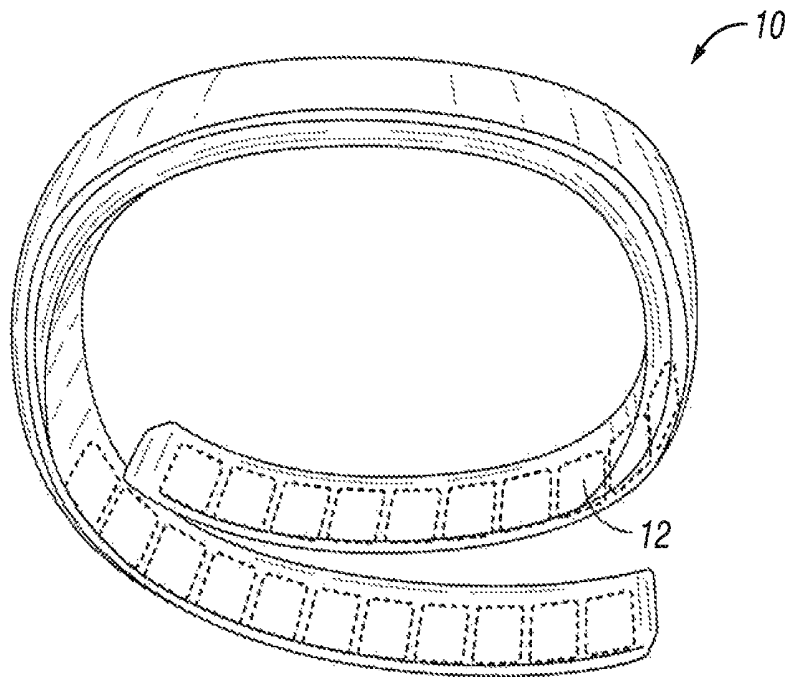

FIG. 1A

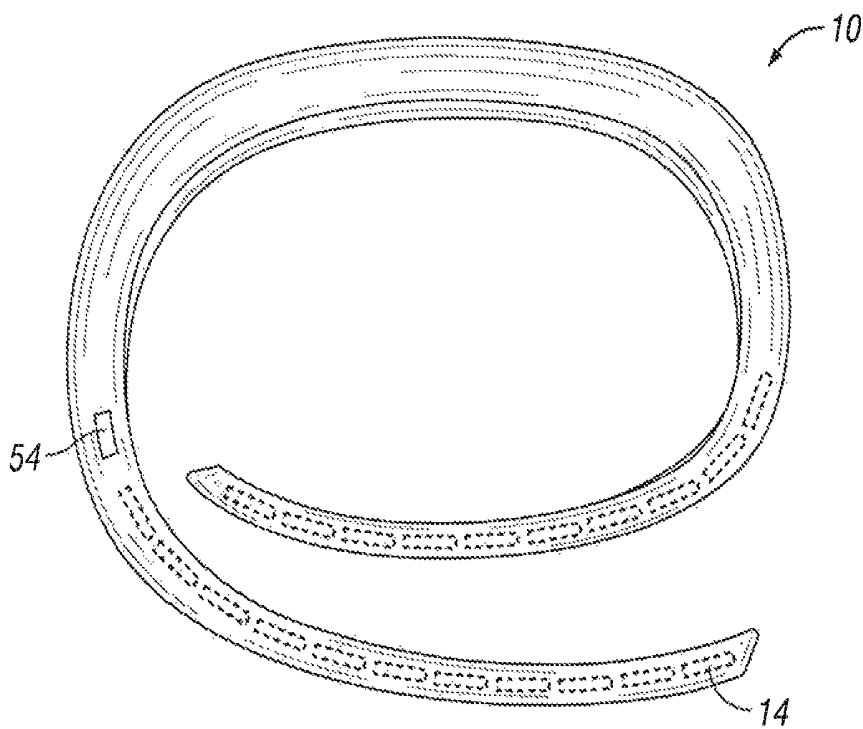

FIG. 1B

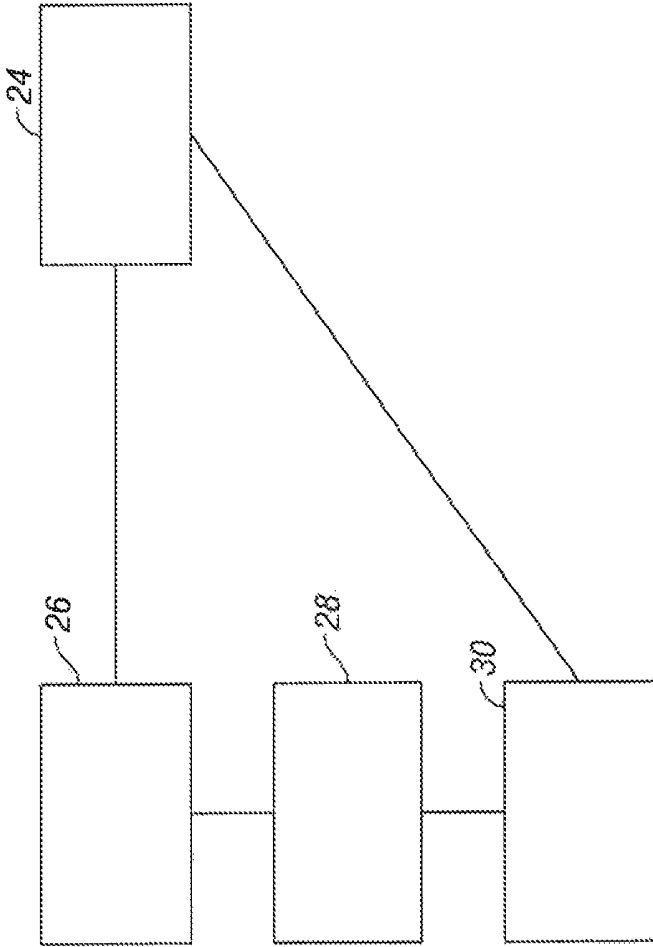

FIG. 2

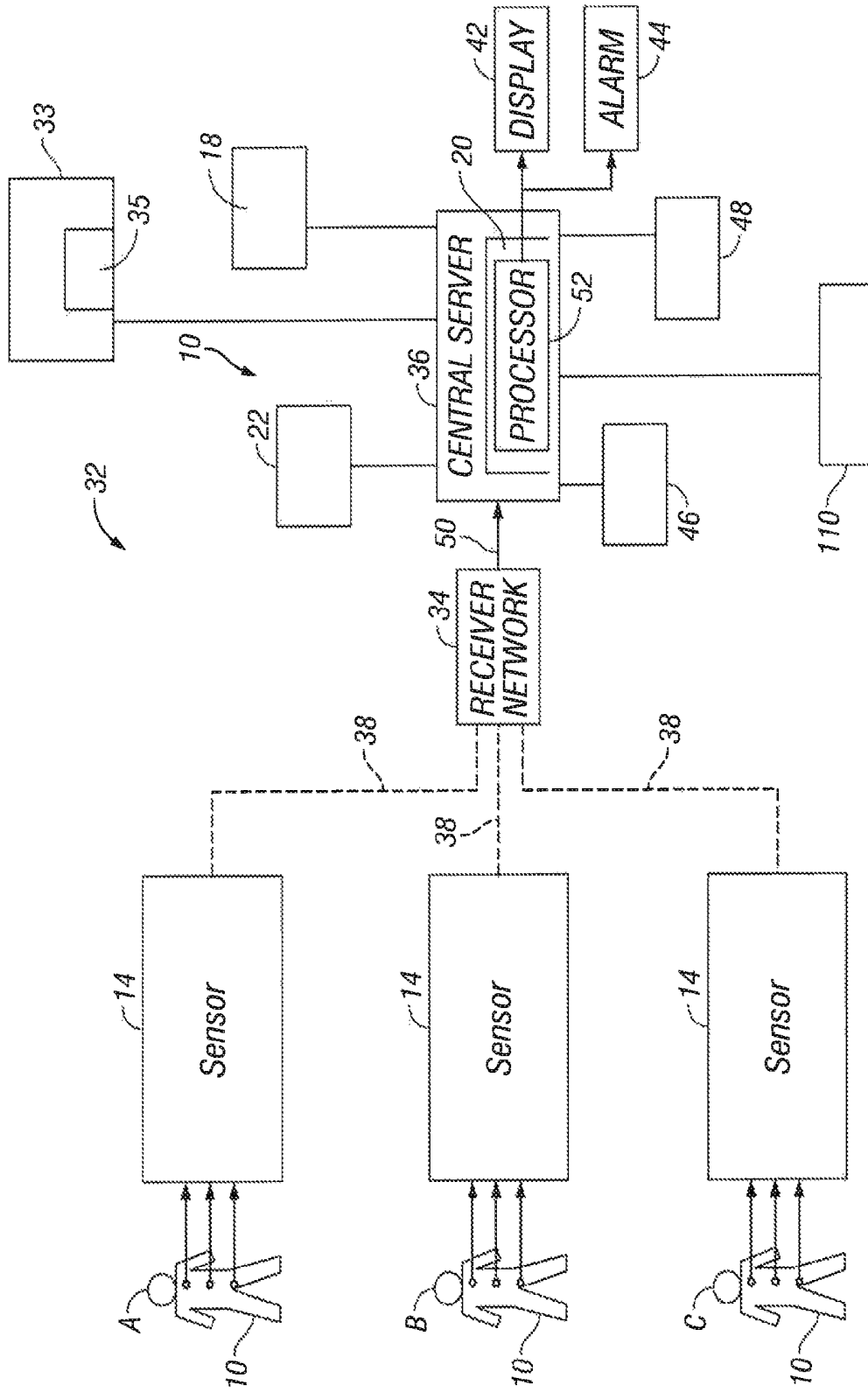

FIG. 3

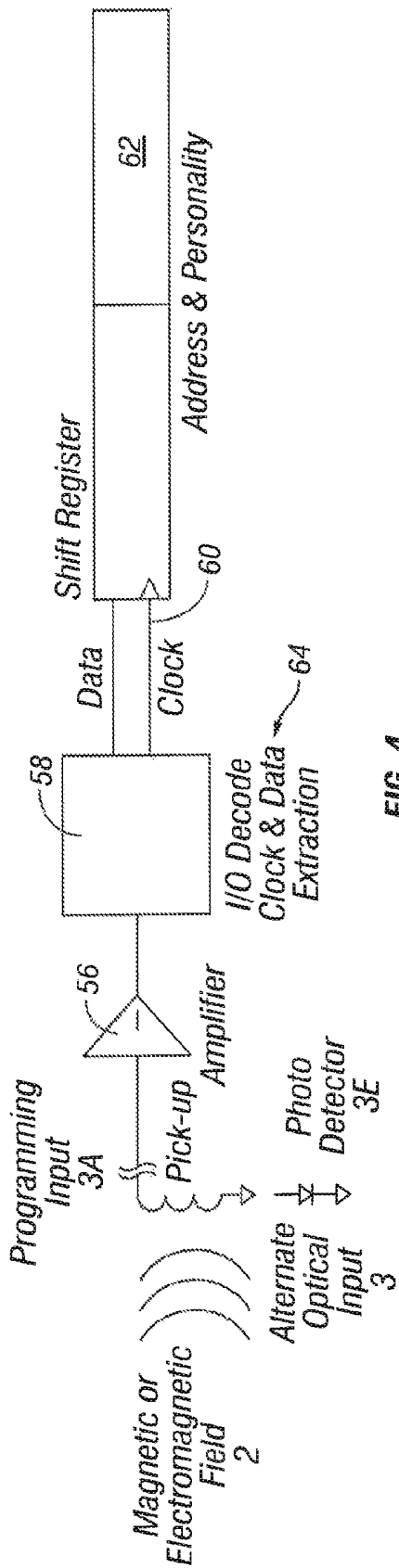

FIG. 4

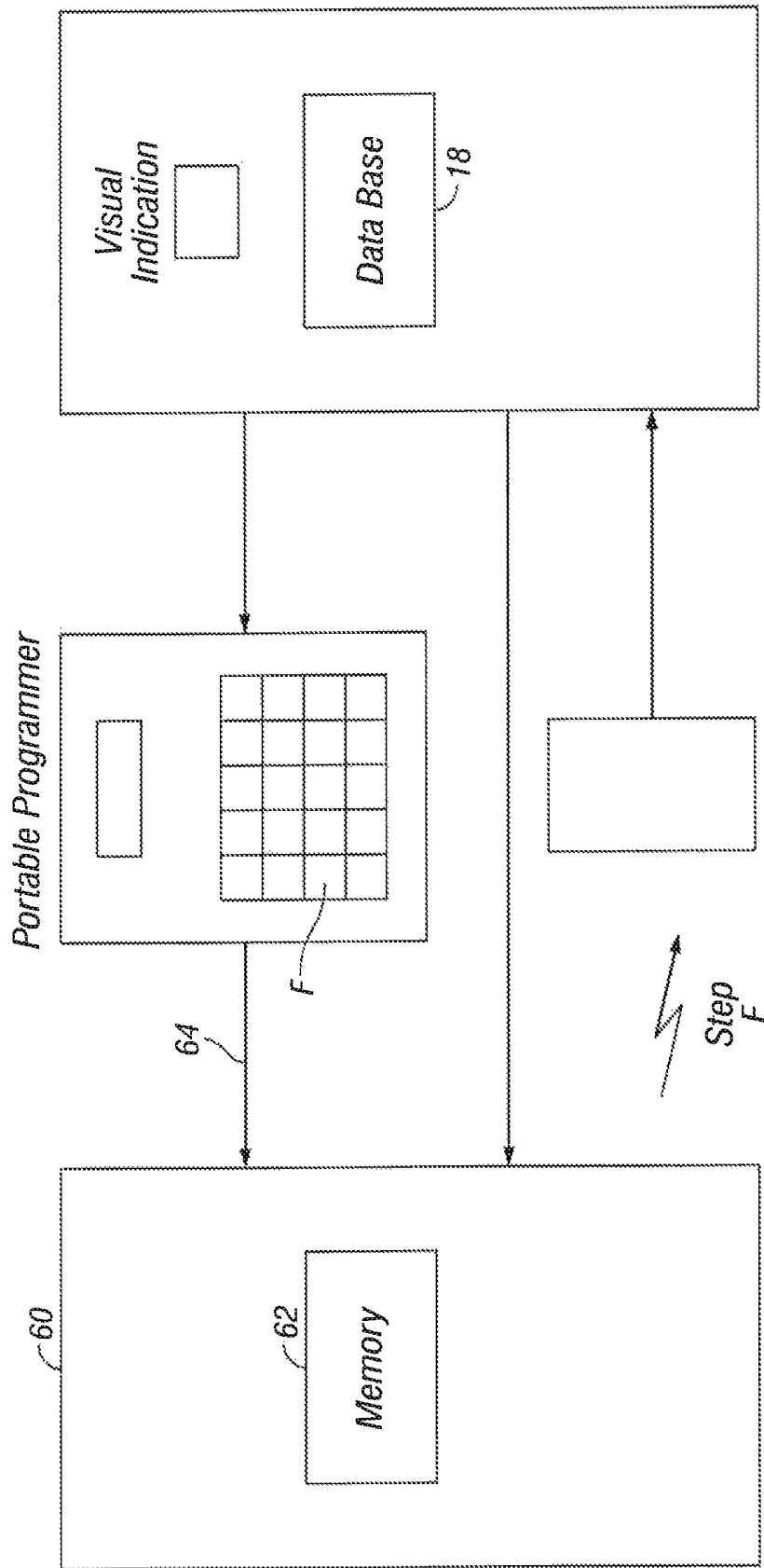

FIG. 5

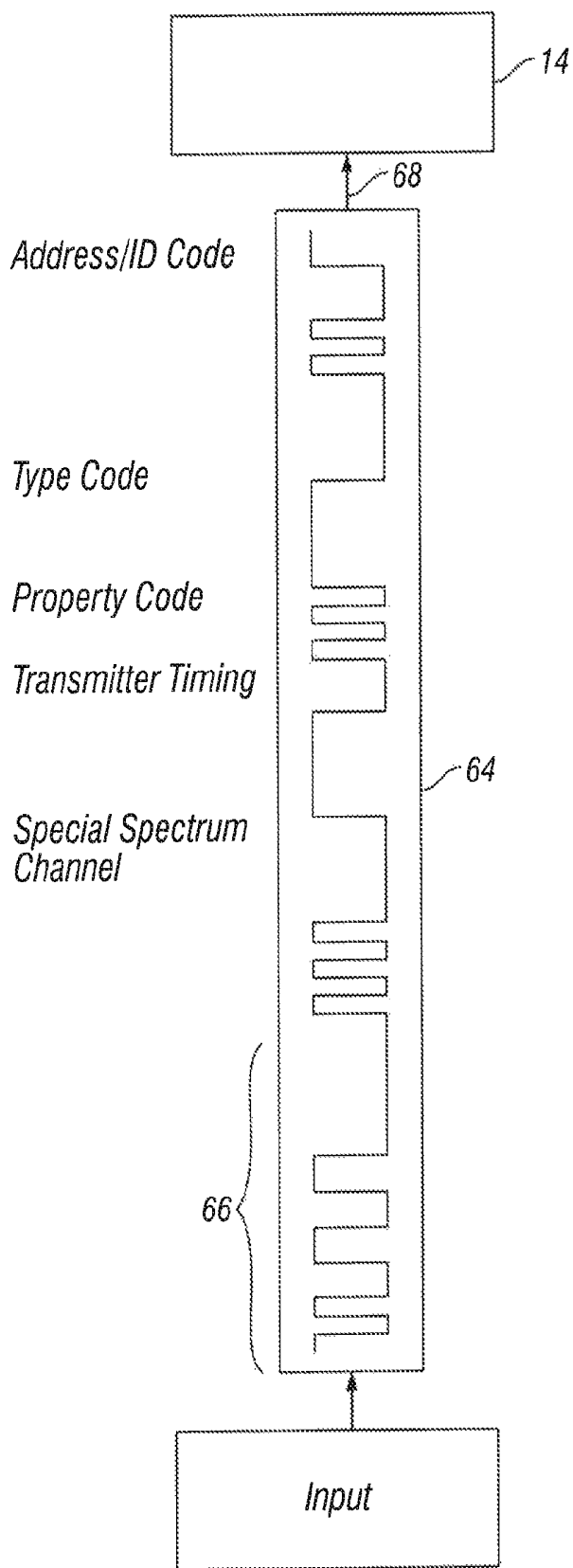

FIG. 6

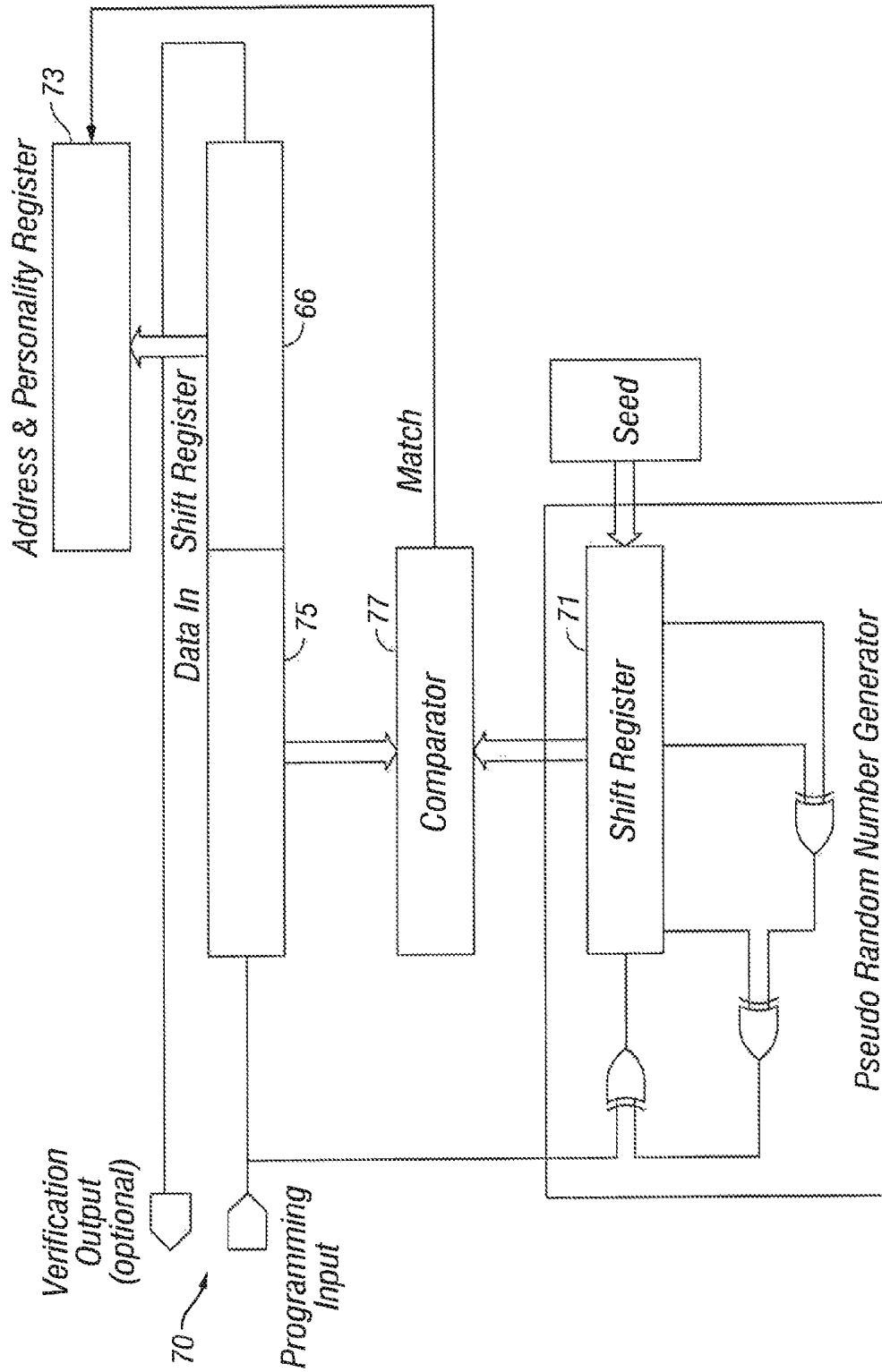

FIG. 7

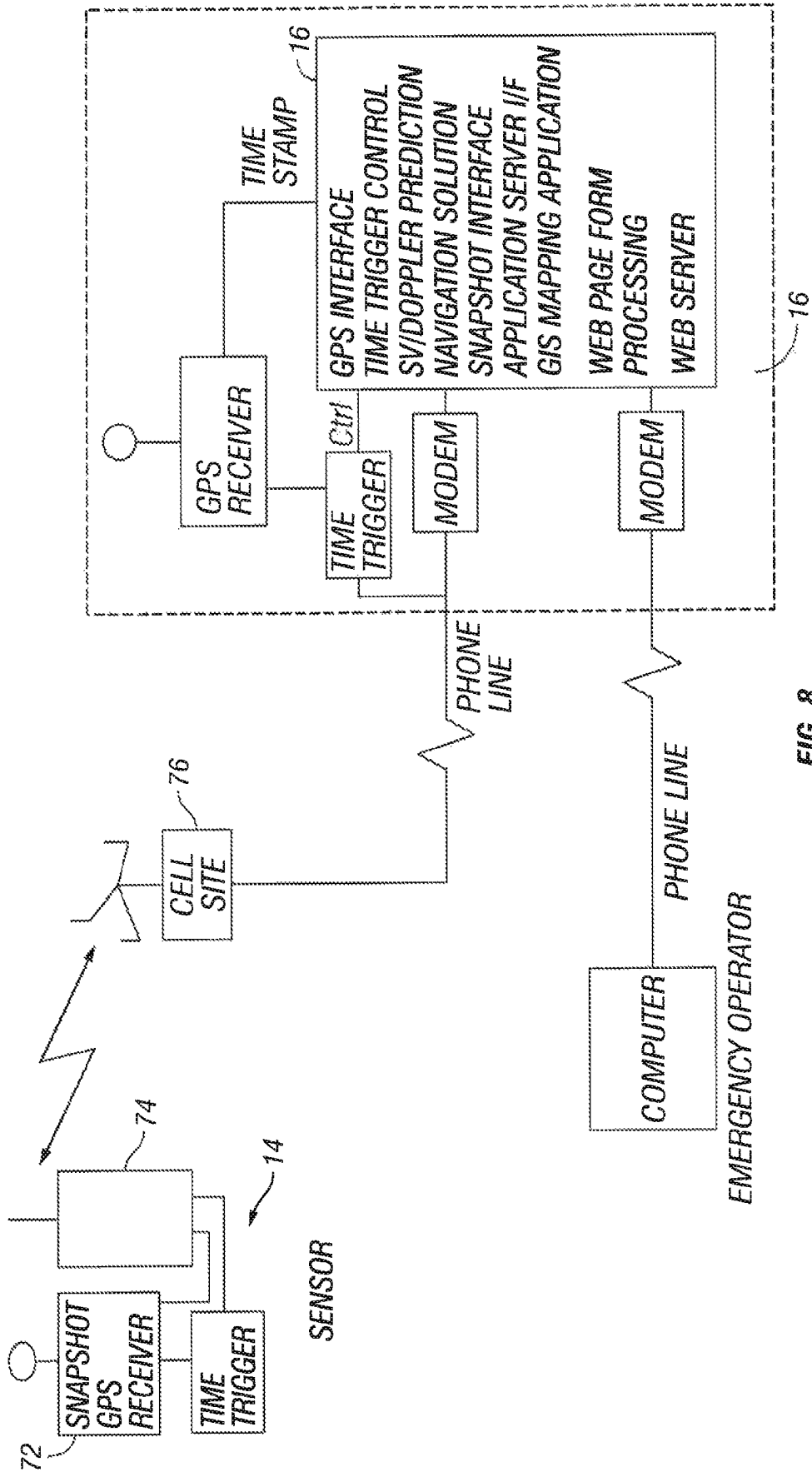

FIG. 8

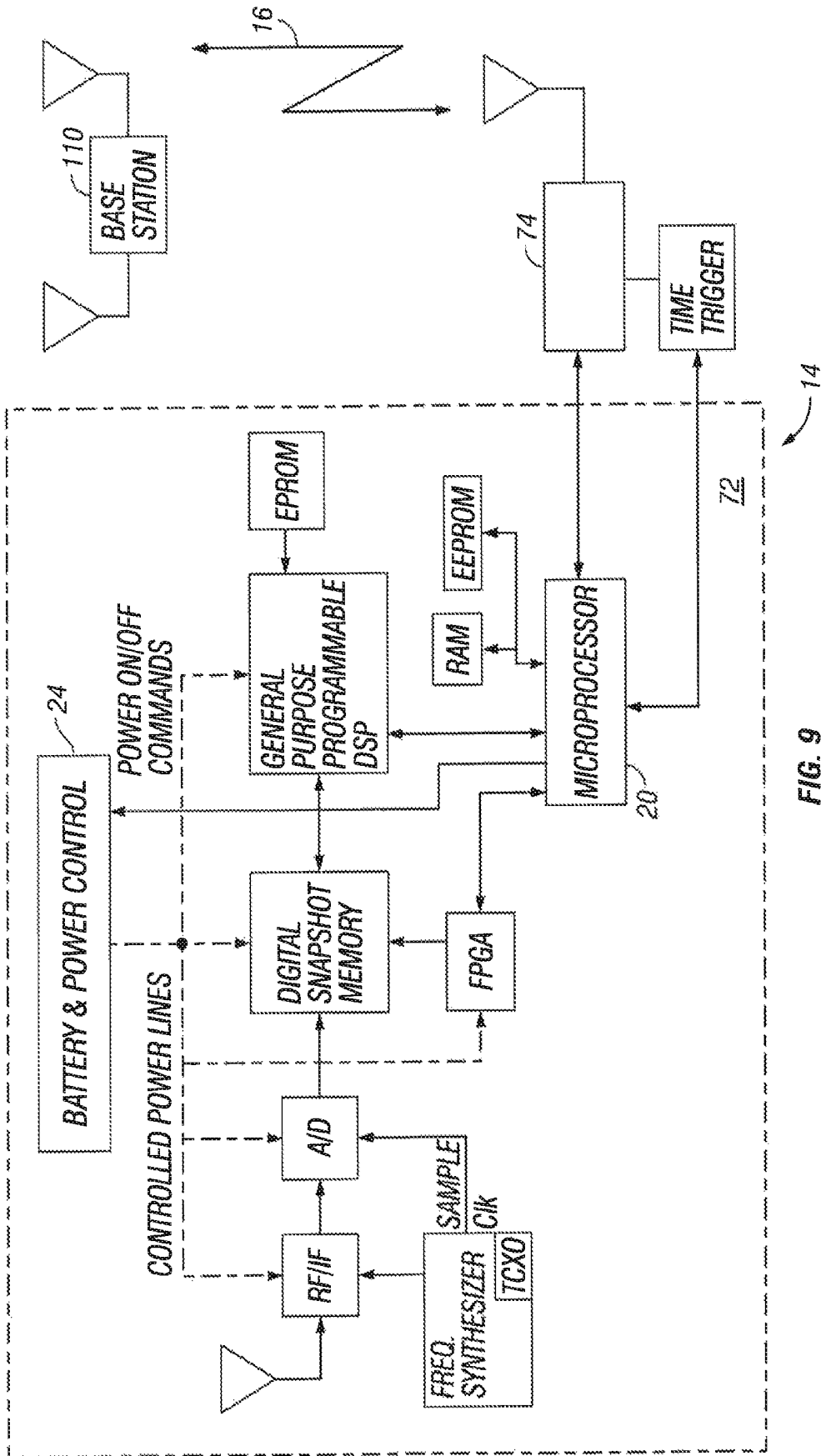
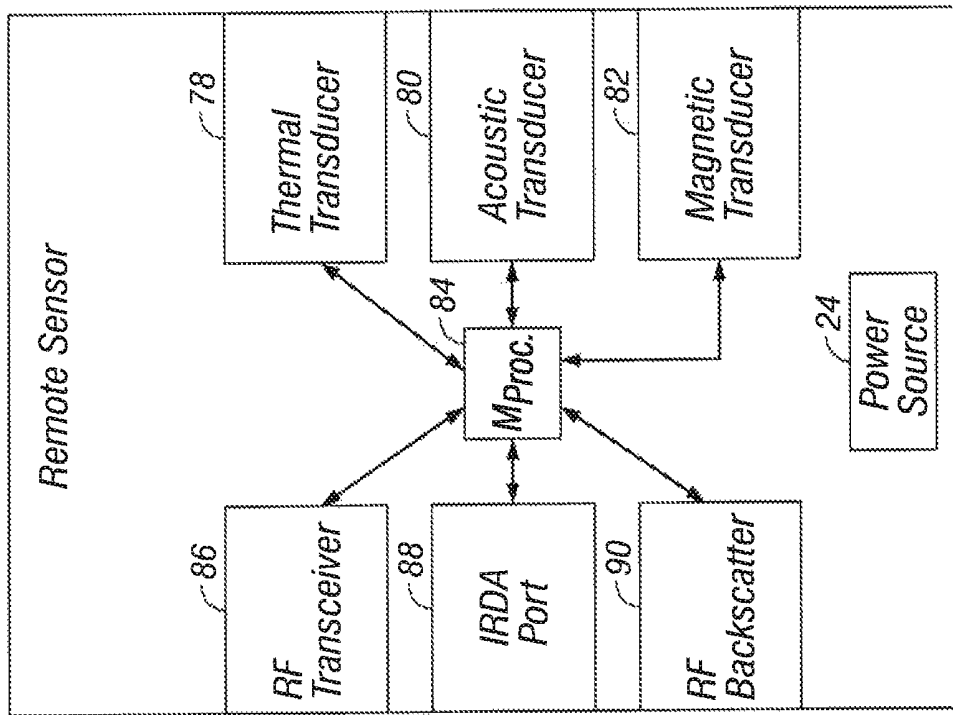

FIG. 9



14

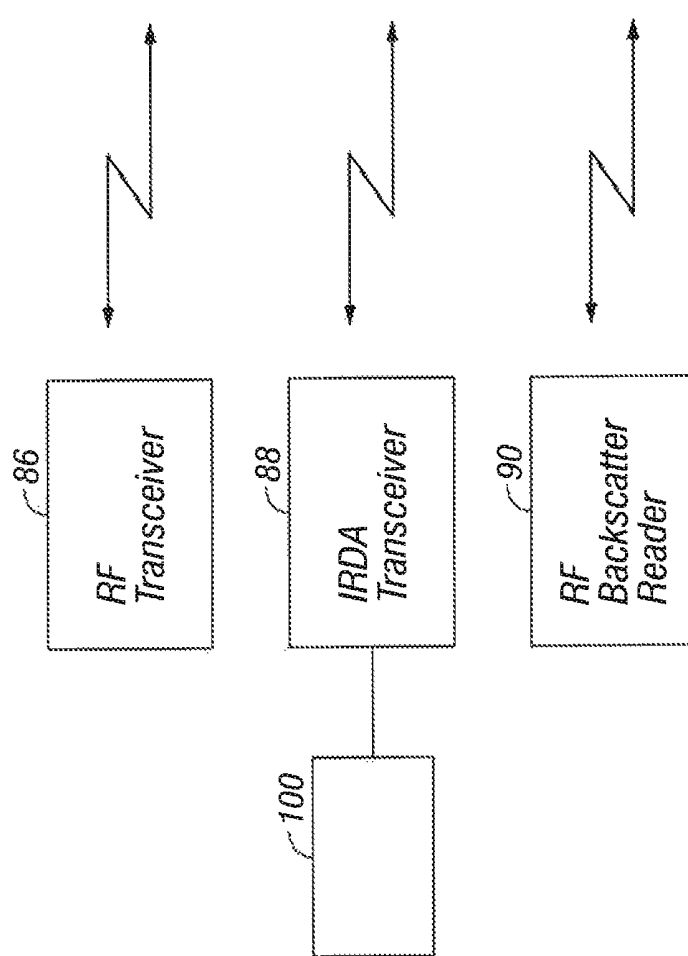

FIG. 10

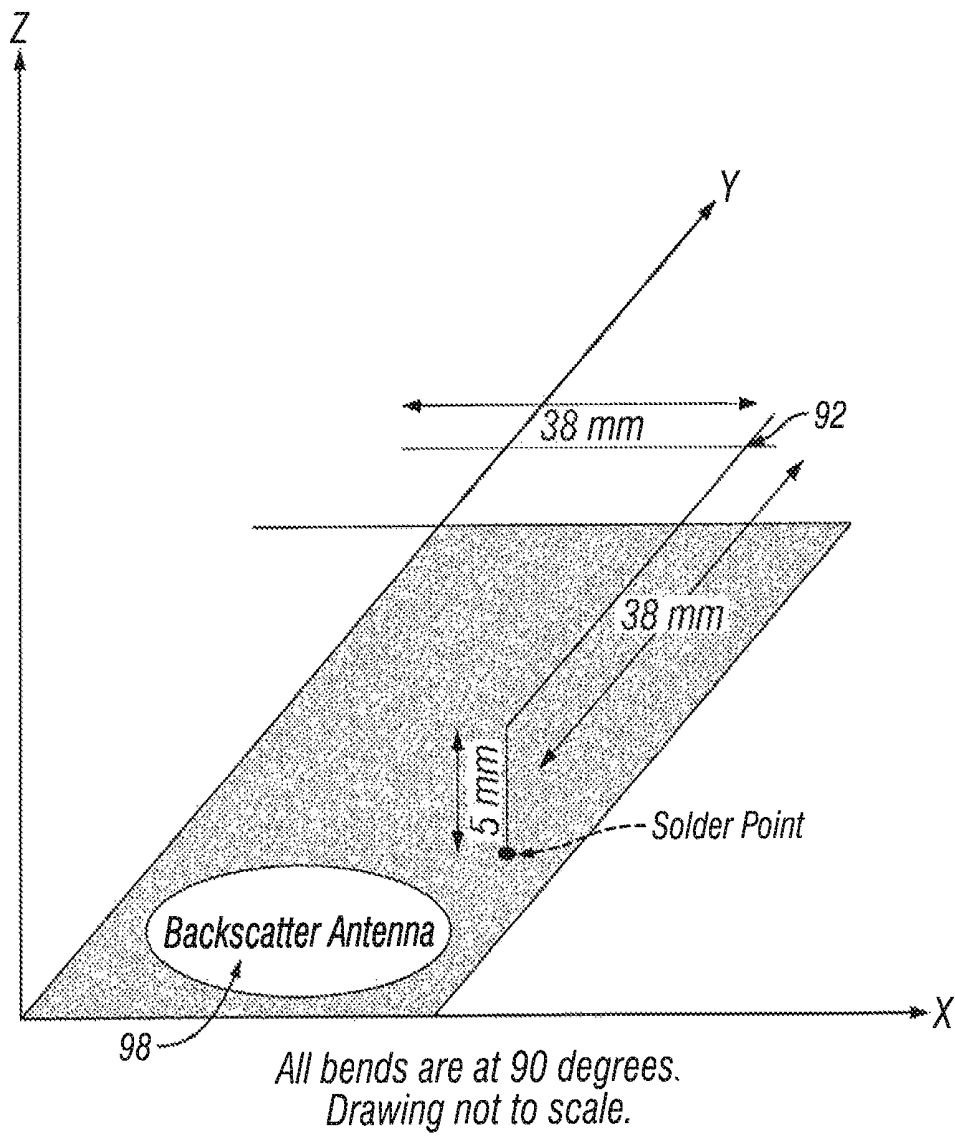

FIG. 11

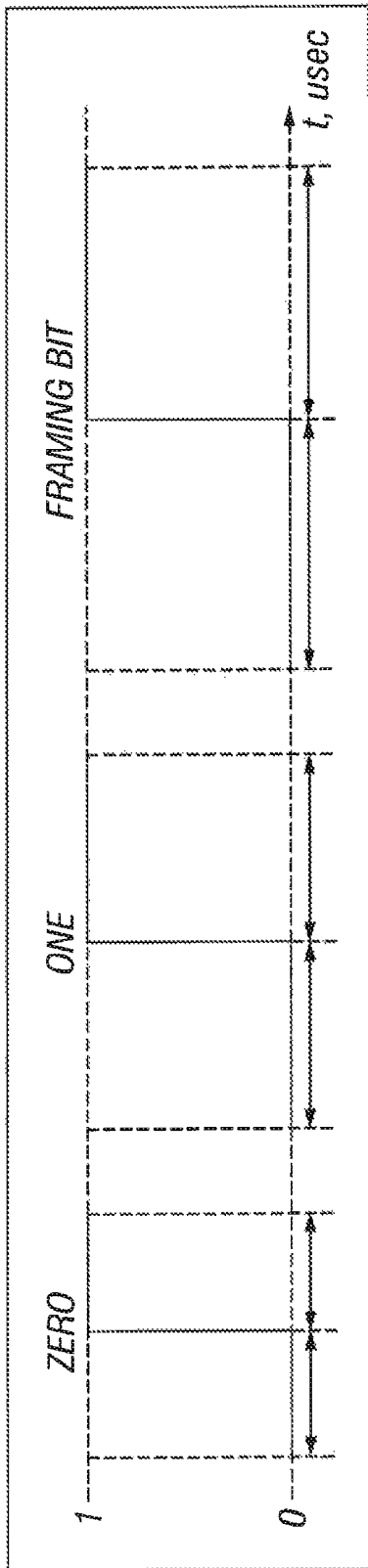

FIG. 12

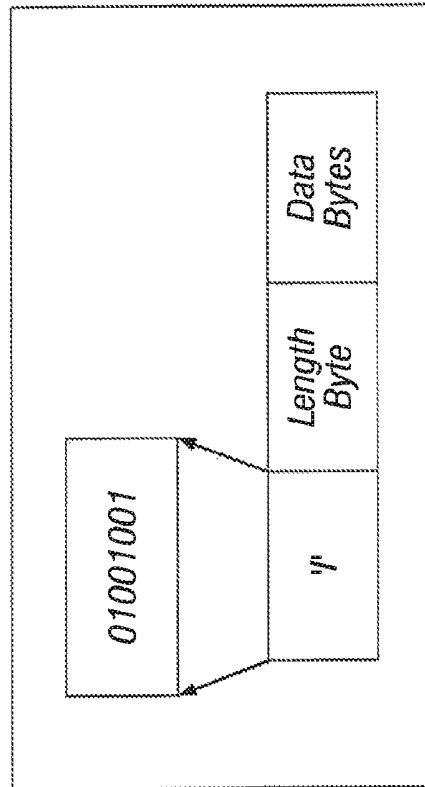

FIG. 13

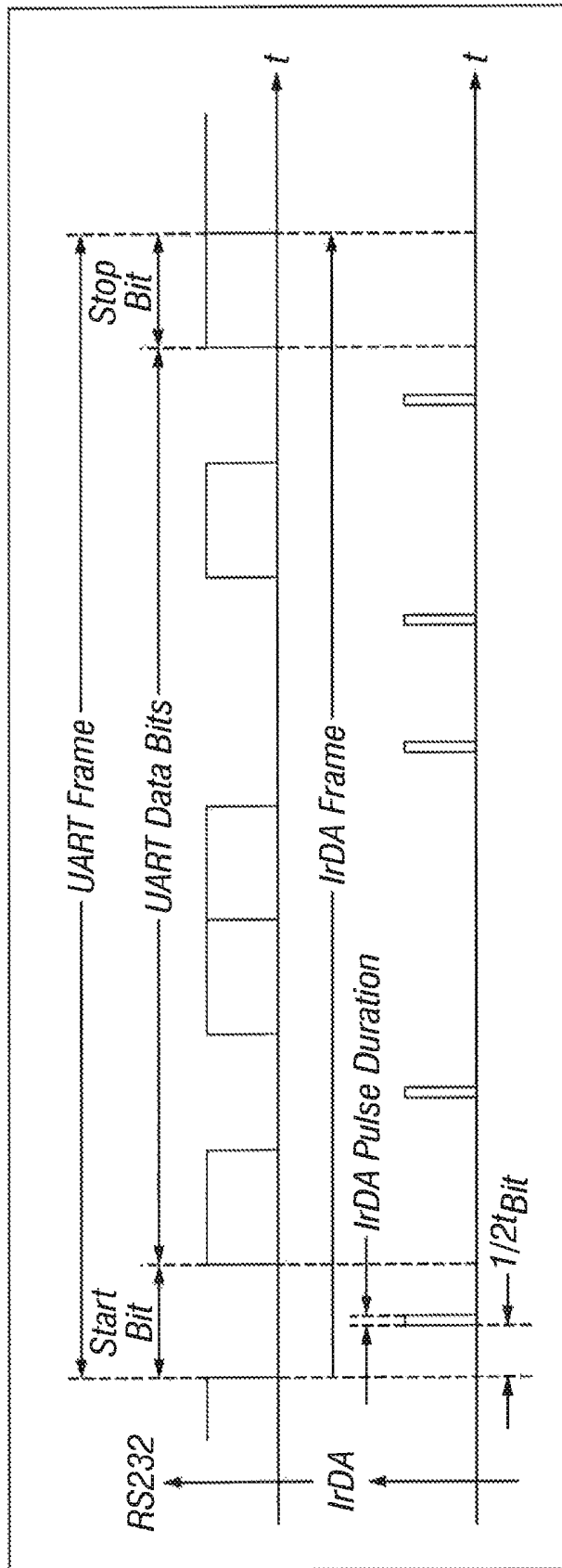

FIG. 14

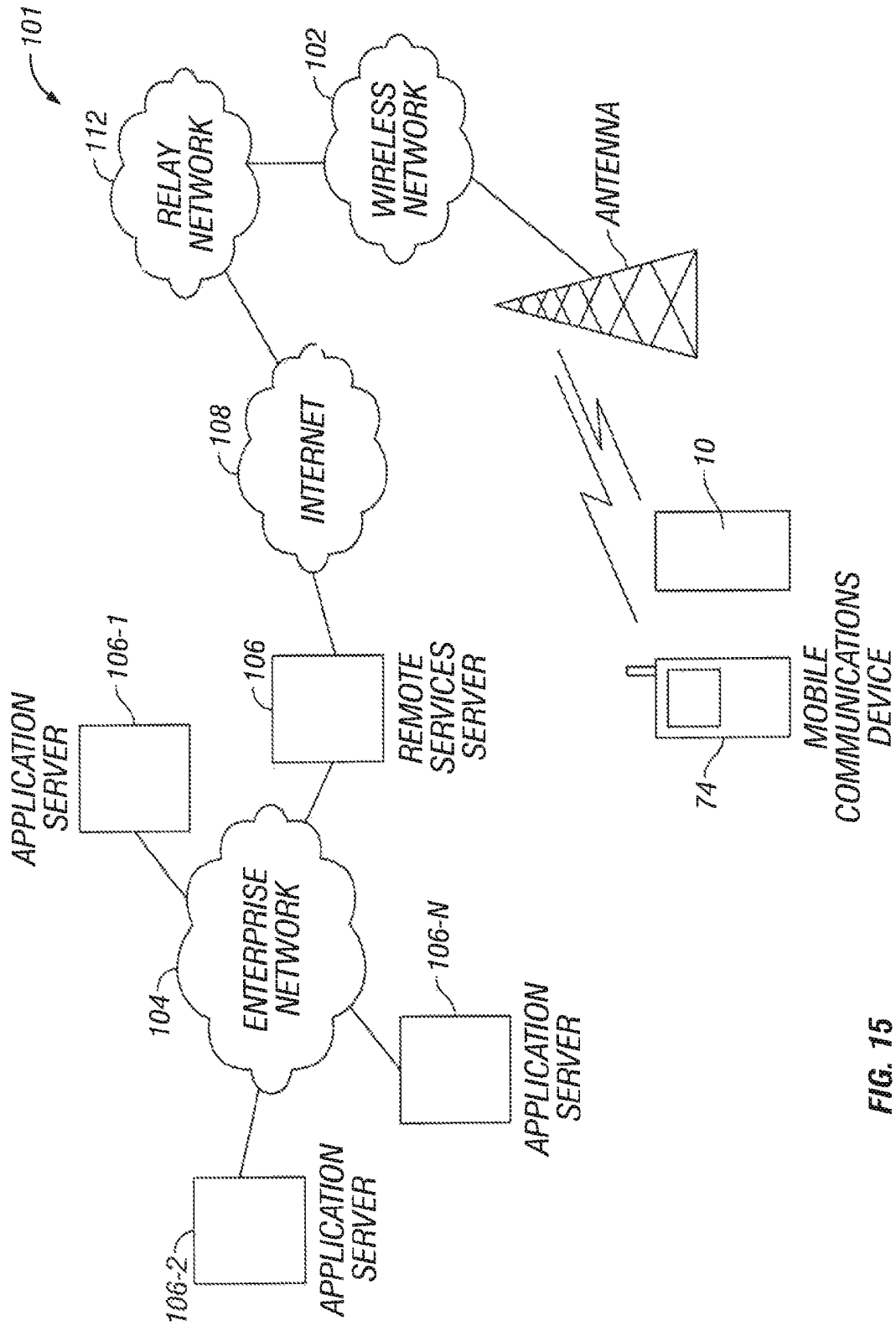

FIG. 15

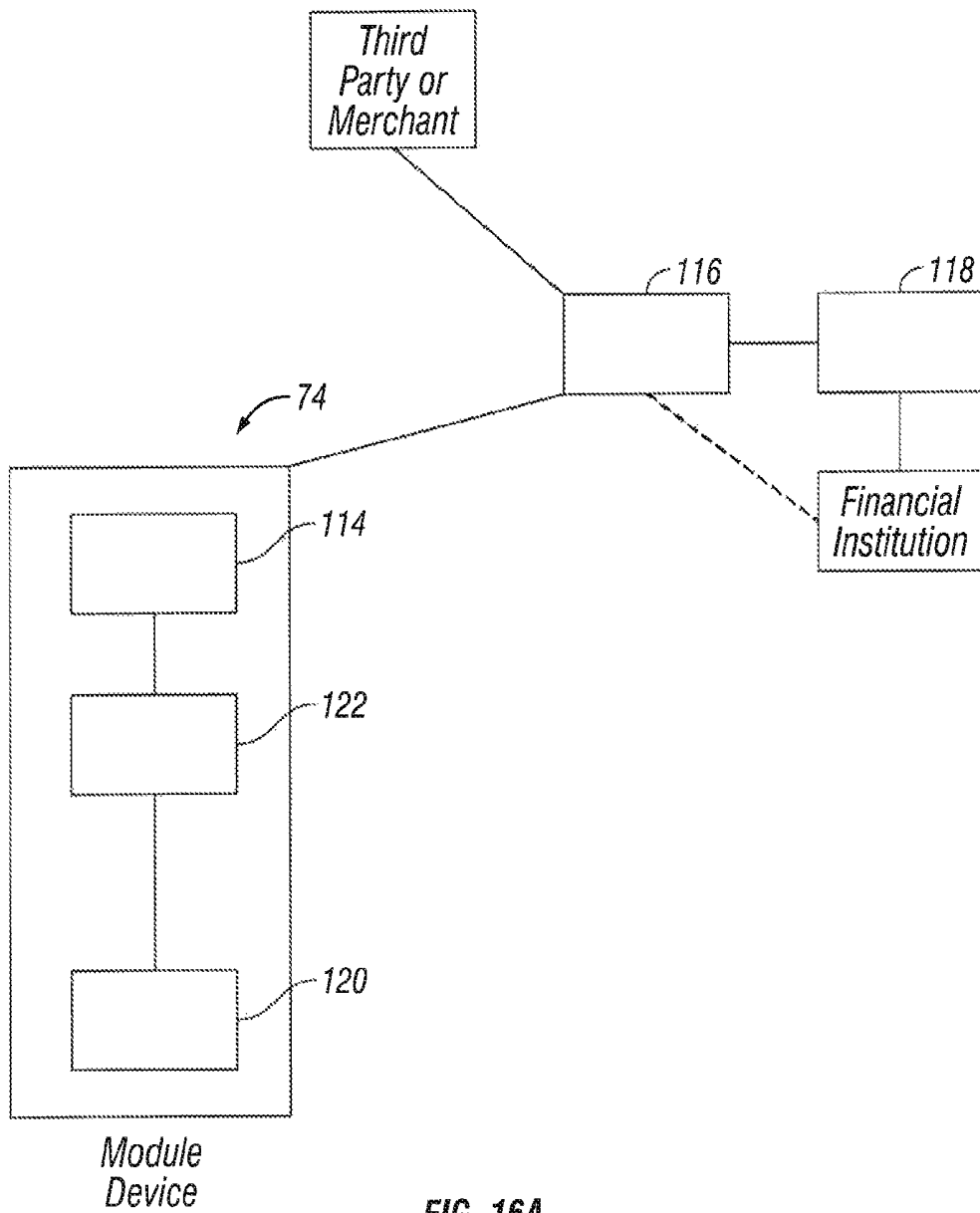

FIG. 16A

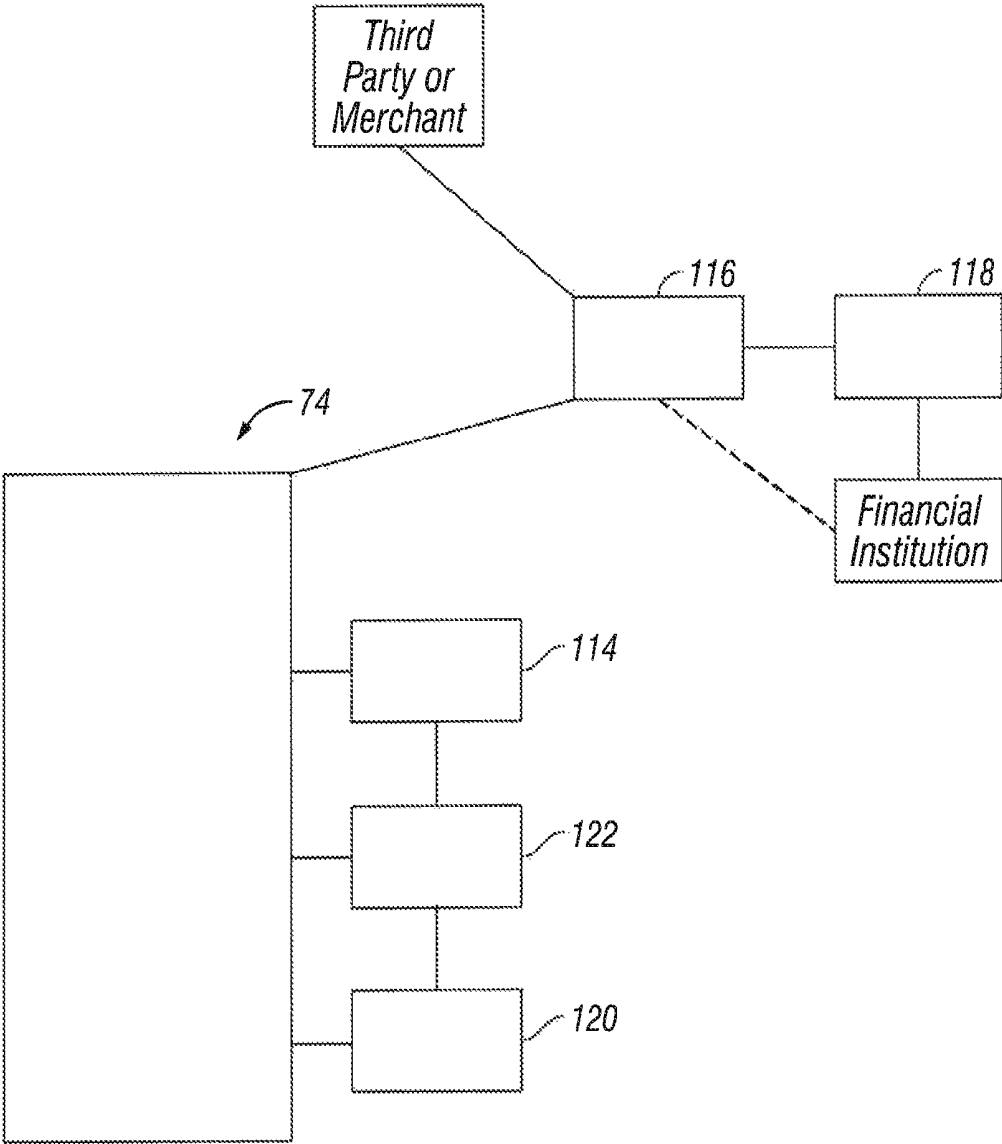

FIG. 16B

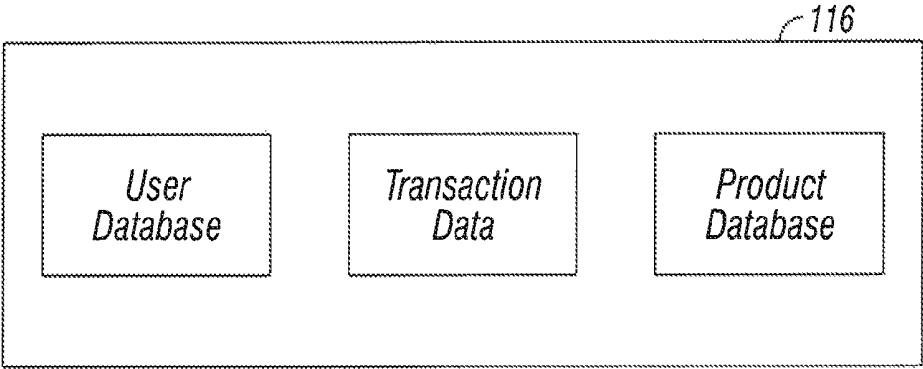

FIG. 16C

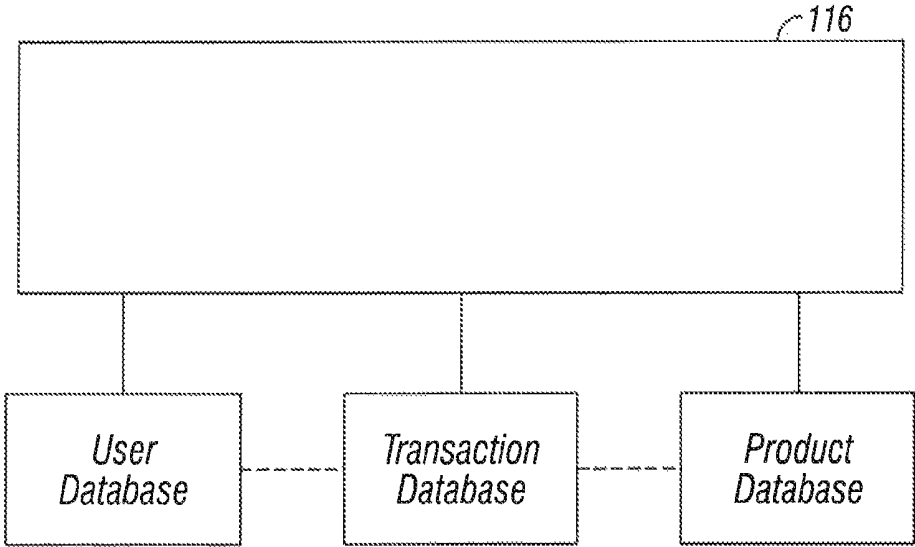

FIG. 16D

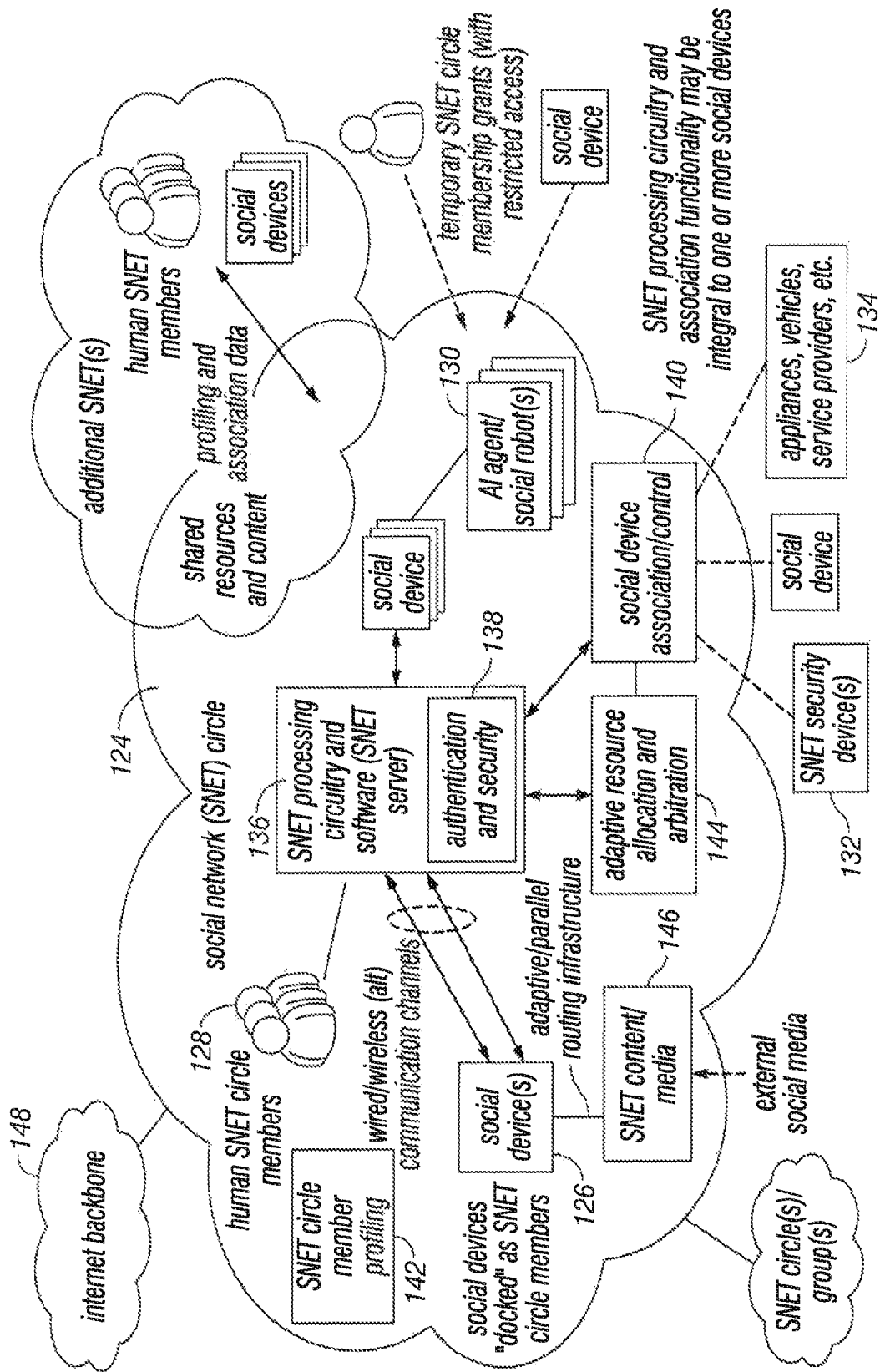

FIG. 17

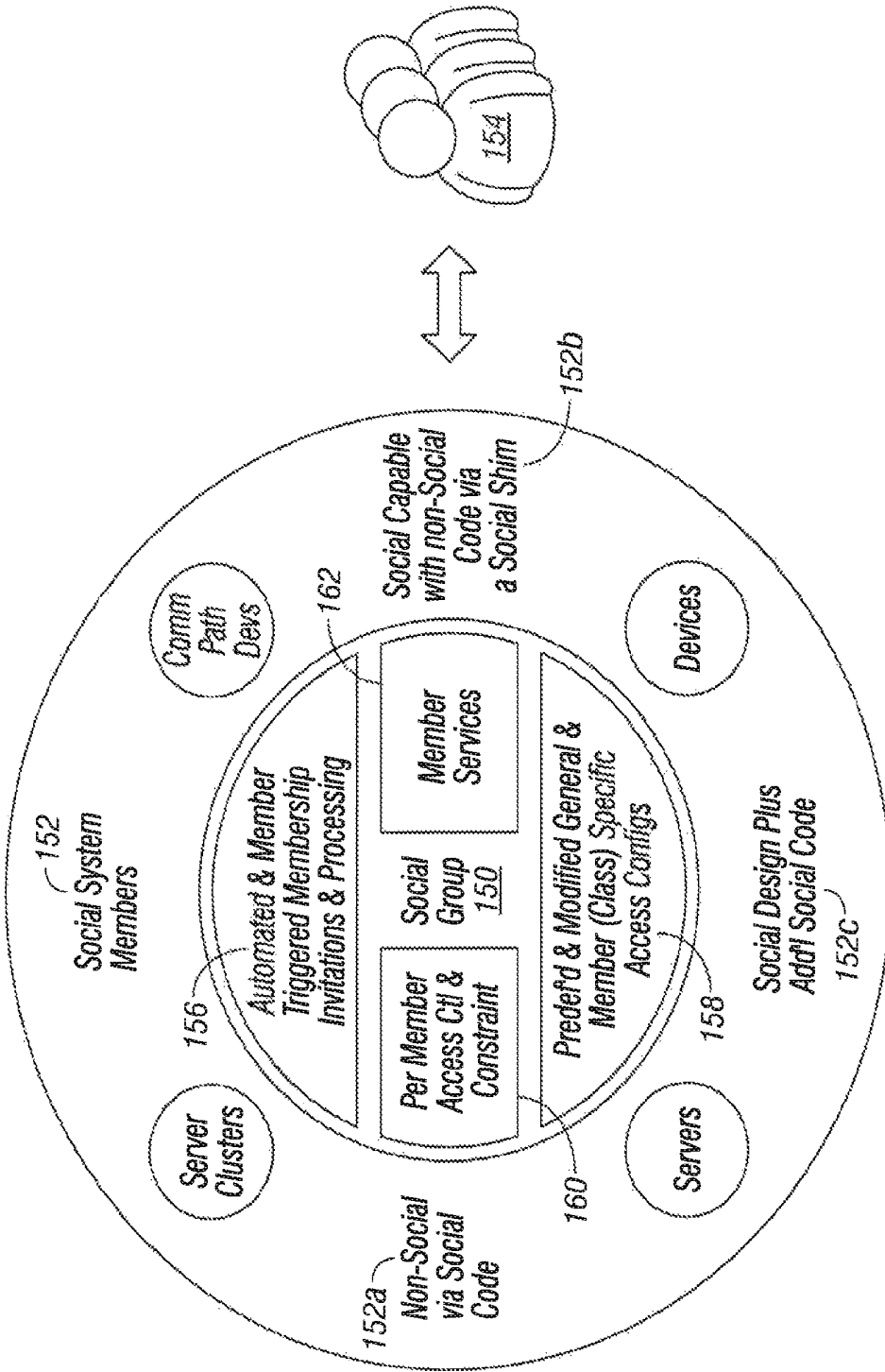

FIG. 18

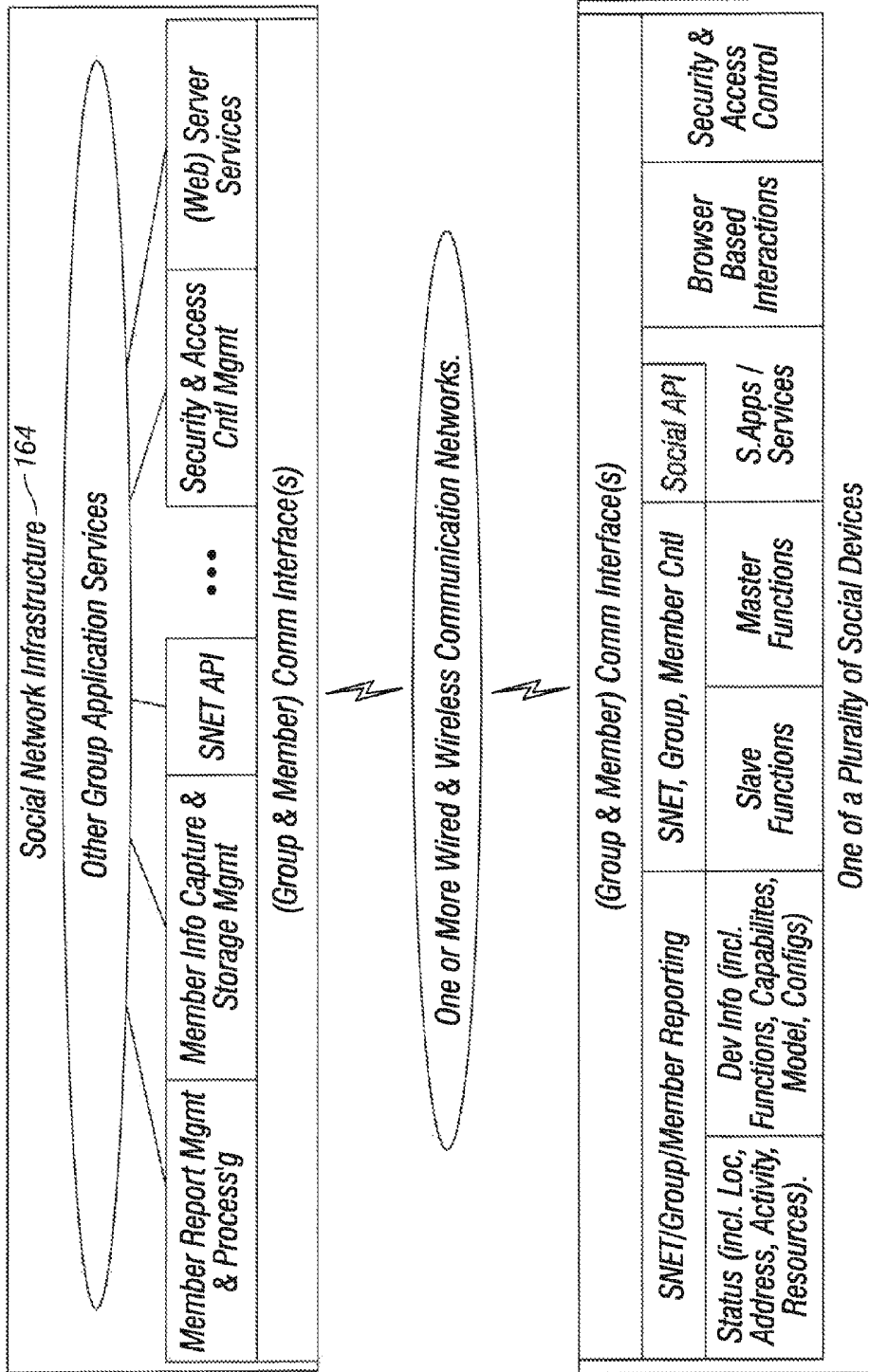

FIG. 19

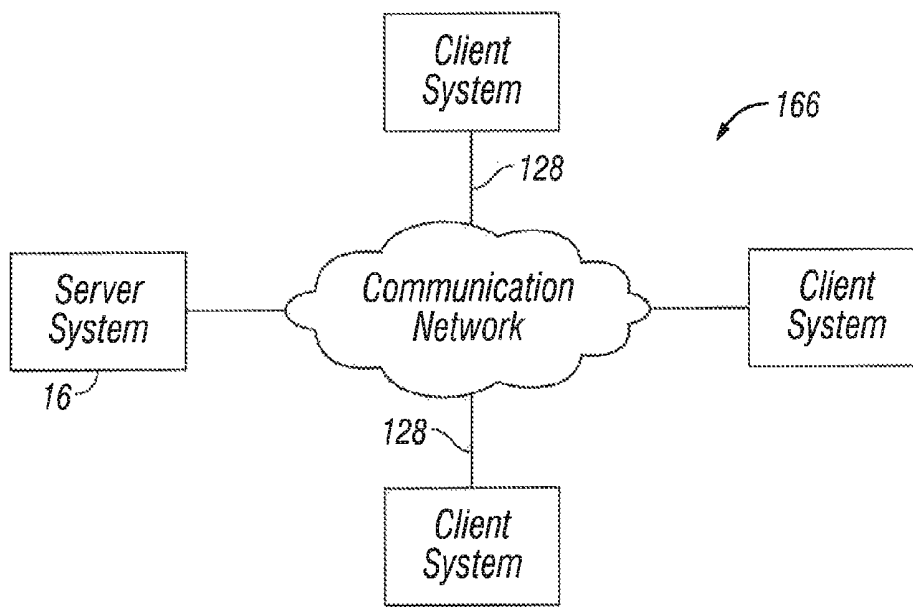

FIG. 20

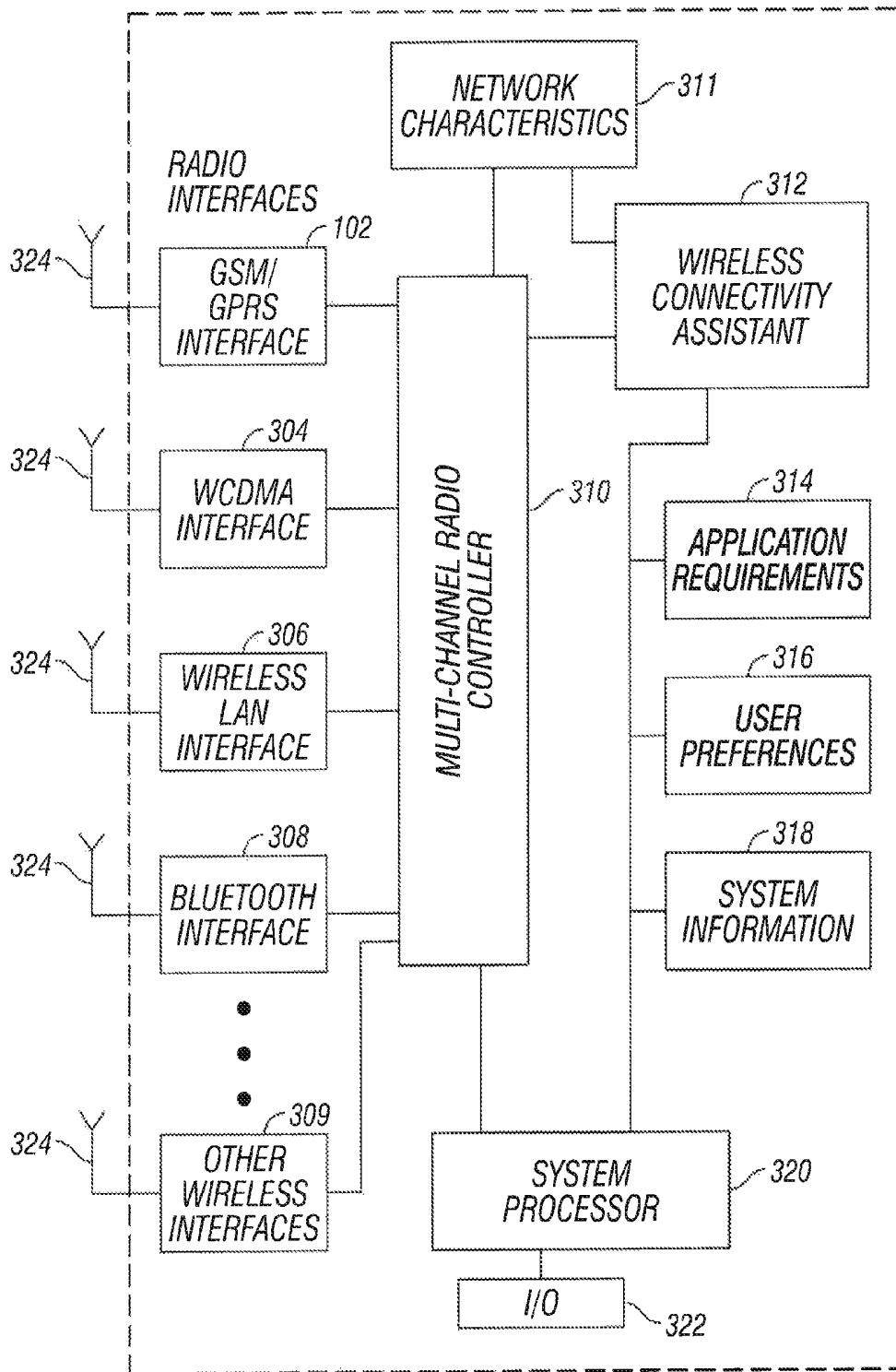

FIG. 21

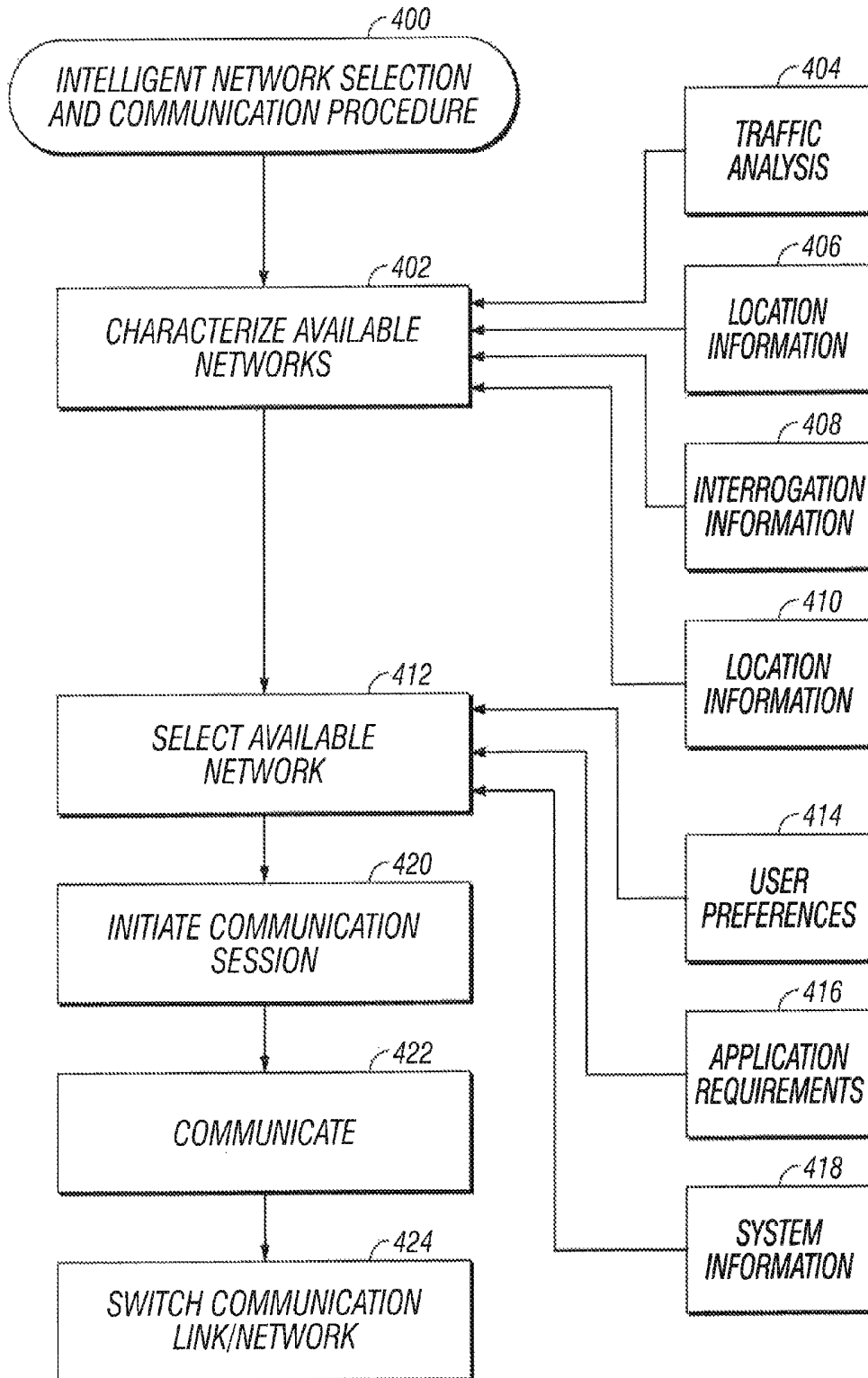

FIG. 22

## MONITORING DEVICE WITH SELECTABLE WIRELESS COMMUNICATION

### CROSS-REFERENCE TO RELATED APPLICATIONS

This application is a continuation of U.S. Ser. No. 13/955,777, filed Jul. 31, 2013, which is a continuation in part of U.S. Ser. Nos. 13/923,909, 13/923,637, 13/923,614, 13/923,809, 13/923,750, 13/923,583, 13/923,560, 13/923,543, and 13/923,937, all filed Jun. 21, 2013 and all of which claim the benefit of U.S. Ser. Nos. 61/772,265, 61/812,083 and 61/823,502. All of the above-identified applications are fully incorporated herein by reference.

### BACKGROUND

#### Field of the Invention

The present invention relates to wearable monitoring devices in communication with telemetry systems with selectable wireless communication.

#### Description of the Related Art

Telemetry systems can be implemented to acquire and transmit data from a remote source. Some telemetry systems provide information about a user's activities.

It is becoming commonplace to use wireless packet data service networks for effectuating data sessions with. In some implementations, unique identifications (ID) need to be assigned to the devices in order to facilitate certain aspects of service provisioning, e.g., security, validation and authentication, et cetera. In such scenarios, it becomes imperative that no two devices have the same indicium (i.e., collision). Further, provisioning of such indicia should be flexible so as to maintain the entire pool of indicia to a manageable level while allowing for their widespread use in multiple service environments.

The telemetry system may incorporate a wireless technology such as wireless fidelity (WiFi); infrared (IR); or ultrasound in order to facilitate finding an object and/or data transmission. As an exemplary implementation, a medical telemetry system can be implemented to remotely monitor the cardiac electrical activity of a plurality of ambulatory patients while they remain within a predefined coverage area. The medical telemetry system may also be implemented to locate and track patients within the coverage area.

One problem with current wireless communications is that a user is typically dependent on a single interface which communicates over a wireless link that can be lost when traveling out of range or in a null coverage area, or lost due to congestion. Although other communication networks may be available, the wireless interface is not able to make use of these other networks. For example, a device communicating with a network utilizing a code division multiple access (CDMA) link may not be able to transition to another network such as a wireless local area network (WLAN) when the CDMA link becomes unavailable. Although some wireless devices may implement more than one transceiver for communicating with different communication networks, these devices do not readily transition between the transceivers, nor do they exhibit flexibility in assessing the worth of the network. Another problem with current wireless communications is that the network connection is not optimized for the application being used. For example, the same network connection for voice communications may not be suitable for video or data transfer.

There is a need for improved systems and methods for conducting wireless communications. There is a further

need for wireless devices to transition between communication networks when a network becomes unavailable. There is yet another need for wireless devices to select between available connections.

### SUMMARY OF THE INVENTION

An object of the present invention is to provide improved monitoring device coupled to telemetry systems.

Another object of the present invention is to provide systems, and their associated methods, for transmitting and relaying information to and from a monitoring device to a telemetry system with ability to transition between communication networks when a network becomes unavailable.

Yet another object of the present invention is to provide systems, and their associated methods, for transmitting and relaying information to and from a monitoring device to a telemetry system with an ability to select between available connections.

These and other objects of the present invention are achieved in a wireless communication system for a monitoring device. One or more sensors are coupled to the monitoring device. The monitoring device has a unique user ID. The one or more sensors acquire user information selected from of at least one of, a user's activities, behaviors and habit information. ID circuitry is at the monitoring device. The ID circuitry includes ID storage, a communication system that reads and transmits the unique ID from an ID storage, a power source and a pathway system to route signals through the circuitry. A multi-protocol wireless controller is at the monitoring device and characterizes available networks to determine current network information. The wireless controller is coupled to one or more wireless interfaces. A wireless connectivity assistant is at the monitoring device and selects one of the available networks based on the current network information and at least one of user preferences, application requirements and system information. A telemetry system is in communication with the monitoring device.

In another embodiment of the present invention, a method of communicating wirelessly with a monitoring device provides a monitoring device with one or more sensors, a unique user ID circuitry and an antenna. The one or more sensors acquire user information selected from of at least one of, a user's activities, behaviors and habit information. Available networks are characterized in order to determine current network information. One of the available networks is selected based on the current network information and at least one of user preferences, application requirements and system information. A telemetry system and the monitoring device then communicate.

### BRIEF DESCRIPTION OF THE DRAWINGS

FIGS. 1(a) and 1(b) illustrate one embodiment of a wearable device of the present invention, where one size fits all.

FIG. 2 illustrates one embodiment of electronics that can be included in the wearable device.

FIG. 3 illustrates one embodiment of a telemetry system of the present invention.

FIG. 4 is a diagram of the programming input schematic of the secure sensor/transmitter array of FIG. 7.

FIG. 5 is a block diagram of the system of programming the sensor/transmitter(s) comprising the secure sensor/transmitter array of FIG. 7.

FIG. 6 is a block diagram of the jam command and security/randomization bits of the secure sensor/transmitter array of FIG. 7.

FIG. 7 is a logic circuit diagram of the sensor/transmitter programming input schematic in one embodiment of the present invention.

FIG. 8 is a block diagram of an embodiment of a computer implemented system for determining the location of a remote sensor utilizing the methods of the present invention.

FIG. 9 is a block diagram illustrating one embodiment of a SNAPSHOT GPS receiver for use according to the present invention.

FIG. 10 is a block diagram of a remote sensor shown in communication with two different external communication devices.

FIG. 11 is a diagram of the active RF and RF backscatter antennas.

FIG. 12 is a diagram of the encoding scheme for the symbols in the active RF protocol.

FIG. 13 is a diagram of the packet structure in the IRDA protocol.

FIG. 14 is a diagram of the encoding scheme in the IRDA protocol.

FIG. 15 illustrates one embodiment of a wireless network that can be used with the present invention.

FIGS. 16(a)-16(d) illustrate various embodiments of the interaction of a wearable device of the present invention with an interaction engine, a transaction engine, a decoding engine, and a payment system and a third party.

FIG. 17 illustrates an embodiment of a social network circle with social devices in accordance with one embodiment of the present invention.

FIG. 18 illustrates an embodiment of a social group with a variety of members in accordance with one embodiment of the present invention.

FIG. 19 is a functional block diagram illustrating a social network infrastructure and social devices in accordance with one embodiment of the invention.

FIG. 20 illustrates a simplified block diagram of a client-server system and network in one embodiment of the present invention.

FIG. 21 is a simplified functional block diagram of a portion of a wireless communication device in accordance with an embodiment of the present invention; and

FIG. 22 is a flow chart of an intelligent network selection and communication procedure in accordance with an embodiment of the present invention.

### DETAILED DESCRIPTION

As used herein, the term engine refers to software, firmware, hardware, or other component that can be used to effectuate a purpose. The engine will typically include software instructions that are stored in non-volatile memory (also referred to as secondary memory). When the software instructions are executed, at least a subset of the software instructions can be loaded into memory (also referred to as primary memory) by a processor. The processor then executes the software instructions in memory. The processor may be a shared processor, a dedicated processor, or a combination of shared or dedicated processors. A typical program will include calls to hardware components (such as I/O devices), which typically requires the execution of drivers. The drivers may or may not be considered part of the engine, but the distinction is not critical.

As used herein, the term database is used broadly to include any known or convenient means for storing data, whether centralized or distributed, relational or otherwise.

As used herein a mobile device includes, but is not limited to, a cell phone, such as Apple's iPhone®, other portable electronic devices, such as Apple's iPod Touches®, Apple's iPads®, and mobile devices based on Google's Android® operating system, and any other portable electronic device that includes software, firmware, hardware, or a combination thereof that is capable of at least receiving the signal, decoding if needed, exchanging information with a transaction server to verify the buyer and/or seller's account information, conducting the transaction, and generating a receipt. Typical components of mobile device may include but are not limited to persistent memories like flash ROM, random access memory like SRAM, a camera, a battery, LCD driver, a display, a cellular antenna, a speaker, a BLUETOOTH® circuit, and WIFI circuitry, where the persistent memory may contain programs, applications, and/or an operating system for the mobile device.

As used herein, the terms "social network" and "SNET" comprise a grouping or social structure of devices and/or individuals, as well as connections, links and interdependencies between such devices and/or individuals. Members or actors (including devices) within or affiliated with a SNET may be referred to herein as "nodes", "social devices", "SNET members", "SNET devices", "user devices" and/or "modules". In addition, the terms "SNET circle", "SNET group" and "SNET sub-circle" generally denote a social network that comprises social devices and, as contextually appropriate, human SNET members and personal area networks ("PANs").

As used herein, the term "wearable device" is anything that can be worn by an individual and that has a back side that in some embodiments contacts a user's skin and a face side. Examples of wearable device include but are not limited to a cap, arm band, wristband, garment, and the like.

As used herein, the term "computer" is a general purpose device that can be programmed to carry out a finite set of arithmetic or logical operations. Since a sequence of operations can be readily changed, the computer can solve more than one kind of problem. A computer can include of at least one processing element, typically a central processing unit (CPU) and some form of memory. The processing element carries out arithmetic and logic operations, and a sequencing and control unit that can change the order of operations based on stored information. Peripheral devices allow information to be retrieved from an external source, and the result of operations saved and retrieved.

As used herein, the term "Internet" is a global system of interconnected computer networks that use the standard Internet protocol suite (TCP/IP) to serve billions of users worldwide. It is a network of networks that consists of millions of private, public, academic, business, and government networks, of local to global scope, that are linked by a broad array of electronic, wireless and optical networking technologies. The Internet carries an extensive range of information resources and services, such as the inter-linked hypertext documents of the World Wide Web (WWW) and the infrastructure to support email. The communications infrastructure of the Internet consists of its hardware components and a system of software layers that control various aspects of the architecture.

As used herein, the term "extranet" is a computer network that allows controlled access from the outside. An extranet can be an extension of an organization's intranet that is extended to users outside the organization that can be

partners, vendors, and suppliers, in isolation from all other Internet users. An extranet can be an intranet mapped onto the public Internet or some other transmission system not accessible to the general public, but managed by more than one company's administrator(s). Examples of extranet-style networks include but are not limited to:

LANs or WANs belonging to multiple organizations and interconnected and accessed using remote dial-up

LANs or WANs belonging to multiple organizations and interconnected and accessed using dedicated lines

Virtual private network (VPN) that is comprised of LANs or WANs belonging to multiple organizations, and that extends usage to remote users using special "tunneling" software that creates a secure, usually encrypted network connection over public lines, sometimes via an ISP

As used herein, the term "Intranet" is a network that is owned by a single organization that controls its security policies and network management. Examples of intranets include but are not limited to:

A LAN

A Wide-area network (WAN) that is comprised of a LAN that extends usage to remote employees with dial-up access

A WAN that is comprised of interconnected LANs using dedicated communication lines

A Virtual private network (VPN) that is comprised of a LAN or WAN that extends usage to remote employees or networks using special "tunneling" software that creates a secure, usually encrypted connection over public lines, sometimes via an Internet Service Provider (ISP)

For purposes of the present invention, the Internet, extranets and intranets collectively are referred to as ("Network Systems").

As used herein, the term (patient monitoring) includes: (i) cardiac monitoring, which generally refers to continuous electrocardiography with assessment of the patient's condition relative to their cardiac rhythm. A small monitor worn by an ambulatory patient for this purpose is known as a Holter monitor. Cardiac monitoring can also involve cardiac output monitoring via an invasive Swan-Ganz catheter, (ii) Hemodynamic monitoring, which monitors the blood pressure and blood flow within the circulatory system. Blood pressure can be measured either invasively through an inserted blood pressure transducer assembly, or noninvasively with an inflatable blood pressure cuff, (iii) Respiratory monitoring, such as: pulse oximetry which involves measurement of the saturated percentage of oxygen in the blood, referred to as SpO<sub>2</sub>, and measured by an infrared finger cuff, capnography, which involves CO<sub>2</sub> measurements, referred to as EtCO<sub>2</sub> or end-tidal carbon dioxide concentration. The respiratory rate monitored as such is called AWRR or airway respiratory rate, (iv) respiratory rate monitoring through a thoracic transducer belt, an ECG channel or via capnography, (v) Neurological monitoring, such as of intracranial pressure. Special patient monitors can incorporate the monitoring of brain waves electroencephalography, gas anesthetic concentrations, bispectral index (BIS), and the like, (vi) Blood glucose monitoring using glucose sensors, (vii) childbirth monitoring with sensors that monitor various aspects of childbirth, (viii) body temperature monitoring which in one embodiment is through an adhesive pad containing a thermoelectric transducer, (ix) Stress monitoring that can utilize sensors to provide warnings when stress levels signs are rising before a human can notice it and

provide alerts and suggestions, (x) rEpilepsy monitoring, (xi) toxicity monitoring, and the like.

Additionally the present invention can be used to detect differences for a variety of blood tests, including but not limited to tests for the following: sodium, potassium, chloride, urea, creatinine, calcium, albumin, fasting glucose, amylase, carcinoembryonic antigen, glycosylated hemoglobin, hemoglobin, erythrocytes hemoglobin and the like.

As used herein, the term wireless power means any form of energy associated with electric fields, magnetic fields, electromagnetic fields, or otherwise that is transmitted between from a transmitter to a receiver without the use of physical electromagnetic conductors and includes for example, a device capable of wireless communication, a communication device capable of wireless communication, a communication station capable of wireless communication, a portable or non-portable device capable of wireless communication, or the like. In some demonstrative embodiments, a wireless device may be or may include a peripheral that is integrated with a computer, or a peripheral that is attached to a computer. In some demonstrative embodiments, the term "wireless device" may optionally include a wireless service.

In various embodiments, the present invention provides a monitoring device **10**, such as a wearable device, where in one embodiment; one size fits all, a patient monitoring device **10**, and the like. As illustrated in FIGS. **1(a)** and **1(b)**, in one embodiment of the present invention, the monitoring device **10** includes a plurality of magnets **12**, with adjacent magnets having opposite polarity, with a length suitable to be worn by all people. In one embodiment, the length of the monitoring device **10** can be 10-12 inches. The magnets **12** are positioned along an interior of the monitoring device **10** to be provided for good conformation to a user's wrist.

One or more sensors **14** are coupled to the monitoring device **10**. The sensors are measuring devices. As a non-limiting example, the measuring device or sensors **14** can include RTSS devices to detect a user's activities, motions, physical parameters, and the like, including but not limited to, a heart rate monitor, a body temperature probe, a conventional pedometer, an accelerometer and the like.

Alternatively, multifunctional sensors **14** which can perform all the aforementioned functions of RTSS may be attached or embedded in monitoring device **10**. In one embodiment, each sensor can be in communication and or connect electronically and/or RF to a telemetry module **16**. A variety of different sensors **14** can be utilized, including but not limited to, an accelerometer based sensor, and pressure based sensors, voltage resistance sensor, a radio frequency sensor, and the like, as recited above.

As a non-limiting example, an accelerometer, well known to those skilled in the art, detects acceleration and thus user activity. The accelerometer provides a voltage output that is proportional to the detected acceleration. Accordingly, the accelerometer senses vibration. This voltage output provides an acceleration spectrum over time; and information about loft time can be ascertained by performing calculations on that spectrum. A microprocessor subsystem, such as disclosed in U.S. Pat. No. 8,352,211, incorporated herein by reference, stores the spectrum into memory and processes the spectrum information to determine activity. Other examples of suitable accelerometer sensors are disclosed in EP 2428774 A1, incorporated herein by reference. Suitable pressure sensors are disclosed in EP 1883798 B1, incorporated herein by reference. A suitable voltage resistance sensor is disclosed in EP 1883798 B1, incorporated herein

by reference. A suitable radio frequency sensor is disclosed in EP 2052352 B1, incorporated herein by reference.

Referring to FIG. 2, in various embodiments, the monitoring device 10, also known as the monitoring device, can include a power source 24, such a battery that can be rechargeable. The battery 24 can be put into a sleep state when not actively used in order to preserve power. A wake up feature allows the battery 24 and other electronics of the monitoring device 10 to “sleep” during non-use or and is initiated into the “wake up” mode by certain predestinated events.

In one embodiment, as illustrated in FIG. 3, a telemetry system server 16 is coupled to a database 18. Each monitoring device 10 is assigned its own unique identification, ID or asset tag or more fully explained hereafter.

The data transmitted by the monitoring device 10 sensors 14 and its ID may be coded by appending a seed to digital data bits. As illustrated in FIG. 3 central processor unit 20 (CPU) validates or rejects received upon detection of the seed string appended to the digital data bits. In the alternative, the digital data bits may be coded and decoded by applying a scrambling algorithm utilizing the seed. A programming device 22 may be configured to transmit data to a sensor 14, also known as a monitoring device, utilizing a variety of alternative transmission means, including, for example, RF, IR, optical, and the like, or a magnetic loop/induction system.

In one embodiment, sensors 14 are configured to be shipped to users in a non-programmable mode with all programming already performed at the factory. A random seed may be communicated to the programming device 22 can a variety of different mechanisms, including but not limited to, via scanning a bar code, manual input, magnetic strip, random number generation, and the like.

Referring again to FIG. 2, in one embodiment, the monitoring device 10 includes a control unit 26 that puts the monitoring device 10 in a low power state. A monitoring system 28 can be included that remains active. The monitoring system 28 wakes up the electronics 30 in the monitoring device 10 from a low power state. The control unit 26 can be notified of awaking of the other components by the monitoring system 28. The control unit 26 can set a status bit on the monitoring system 28 only when the battery 24 needs to be in a full power state. The control unit 26 then forces a power cycle.

Referring to FIG. 3, one embodiment of a telemetry system 32 is illustrated. The telemetry system 32 is in the communication with the sensors 14 and or monitoring device 14 and ID of the monitoring device 10 and can include one or more receivers 34, a central server 36 with the CPU 20. The telemetry system 32 can optionally include a display 42 and an alarm 44. The telemetry system 32 receives information from sensors 14 and or the monitoring device of a user’s habits, activities, and the like, and then processes this information. Monitoring device 10 with its unique ID and sensors 14 is assigned to a specific user in order to track and/or monitor that user. For illustrative purposes assume that three users A, B AND C are being tracked and monitored by the telemetry system 32. It should, however, be appreciated that the telemetry system 32 may be implemented to track and/or monitor a much larger number of users.

In various embodiments, the telemetry system 32 can send firmware updates or repairs to the monitoring device 14 during an update mode of the monitoring system, when the monitoring device is not in use by the user. The update mode can be when the user does not know that the monitoring

device is being up-dated. The update mode can occur without disrupting service to the user. The firmware update can be sent by the telemetry system 32 directly or indirectly to the monitoring device 14, with the firmware update or a copy of the firmware update then resides on the monitoring device 14.

In one embodiment of the present invention, radio frequency (RF) devices that are sensors 14 and/or chips may serve as the identifying devices. Each source, sensor 14, ID and the like can carry a fixed radio frequency chip encoded with identifying data which may be correlated to the individual participants, parts or objects.

Telemetry system 32 of the present invention may include a Real-Time Location System (RTLS) 46 and Real-Time Sensing System (RTSS) 48 with RF technology. The RF technology may include active and/or passive RFID sensors 14 and an RF wireless array system as a receiver 34. The RF technology in the RTLS 46 and RTSS 48 may include UWB technology (e.g., IEEE 802.15), WLAN technology (e.g., IEEE 802.11), SAW RFID positioning system technology, GPS technology, and the like.

The sensors 14 may communicate directly with each other and/or relay telemetry data directly to base receiving RF device(s) or base receivers 34. The base receivers 34 may forward the telemetry data to a base computer either through a direct link or through a Network System 101. Alternatively the telemetry data may be forwarded to end user devices, including but not limited to, laptops, mobile devices and the like, either directly or through a Network System 101. The comprehensive telemetry system 32 using RF technologies such as UWB, ZigBee, Wi-Fi, GPS data system can be utilized as described above.

The readers/antennae may be interconnected using a LAN, such as Ethernet to provide a Network System 101 communication infrastructure for the computers and servers. Active and passive RFID sensors 14 may be employed. The active sensors 14 (RFID) may have a two-way communication function, which allows the base computer system to dynamically manage the sensors 14; vary update rates; send self-identification and telemetry data.

The active sensors 14 may employ dual-radio architecture. In one embodiment, active sensors 14 transmit radio pulses, which are used to determine precise two-dimensional or three-dimensional location and a conventional bi-directional radio, which is used as a control and telemetry channel with a sensor update rate.

The monitoring device 10 gathers telemetry data, communicates that data to a base station, BLUETOOTH® enabled device, or smart phone and the like. The monitoring device can receive firmware updates and repairs from the telemetry system, as previously stated, directly or indirectly from the base station, via a BLUETOOTH® enabled device, and the like. The monitoring device 10 can receive updates wirelessly. The base station can receive firmware updates from Network Systems 101, take telemetry data from the monitoring device 10 and transfer it to Network Systems 101. Telemetry data received from the base station is analyzed by servers and presented to an end user. Any third party device can receive data from the monitoring device 10 wirelessly and deliver information to the servers for processing.

In one embodiment, the monitoring device 10 uses an accelerometer, gyroscope, GPS sensor, a BLUETOOTH® chip, and a heart rate monitor.

As a non-limiting example, for heart monitoring, the accelerometer, sensor 14, determines when to sample the sensors 14 and to improve the accuracy of the heart rate

monitor. The gyroscope detects movement and orientation and the GPS sensor is used to determine location of the user. A BLUETOOTH® chip allows the device to connect wirelessly to other third party devices.

As a non-limiting example, a heart rate monitor **14** detects the user's heart rate in order to accurately determine the user's activity level, behavioral patterns and the like.

An Artificial Intelligence (AI) or Machine Learning-grade algorithms is used to identify the user's activities, behaviors, behaviors and perform analysis. Examples of AI algorithms include Classifiers, Expert systems, case based reasoning, Bayesian networks, and Behavior based AI, Neural networks, Fuzzy systems, Evolutionary computation, and hybrid intelligent systems. A brief description of these algorithms is provided in Wikipedia and stated below.

Classifiers are functions that can be tuned according to examples. A wide range of classifiers are available, each with its strengths and weaknesses. The most widely used classifiers are neural networks, support vector machines, k-nearest neighbor algorithms, Gaussian mixture models, naive Bayes classifiers, and decision trees. Expert systems apply reasoning capabilities to reach a conclusion. An expert system can process large amounts of known information and provide conclusions based on them.

A case-based reasoning system stores a set of problems and answers in an organized data structure called cases. A case based reasoning system upon being presented with a problem finds a case in its knowledge base that is most closely related to the new problem and presents its solutions as an output with suitable modifications. A behavior based AI is a modular method of building AI systems by hand. Neural networks are trainable systems with very strong pattern recognition capabilities.

Fuzzy systems provide techniques for reasoning under uncertainty and have been widely used in modern industrial and consumer product control systems. An Evolutionary Computation applies biologically inspired concepts such as populations, mutation and survival of the fittest to generate increasingly better solutions to the problem. These methods most notably divide into evolutionary algorithms (e.g., genetic algorithms) and swarm intelligence (e.g., ant algorithms). Hybrid intelligent systems are any combinations of the above. It is understood that any other algorithm, AI or otherwise, may also be used. Examples of suitable algorithms that can be used with the embodiments of the present invention are disclosed in EP 1371004 A4.

EP 1367534 A2, US 20120226639 and US 20120225719, are all incorporated fully herein by reference.

In various embodiments, the monitoring device **10** has additional features. In one embodiment, the monitoring device **10** changes color, via infrared LEDs, to accurately match the wearer's skin tone. This creates a seamless and more personal integration of technology into the user's daily life. In this embodiment, there is skin contact with the monitoring device **10**.

In another embodiment, the monitoring device **10** remotely reminds and can be used to administer medications. As a non-limiting example, the monitoring device **10** can inject adrenalin. In one embodiment, the monitoring device **10** has sleep pattern recognition based on movement and heart rate.

In various embodiments, the monitoring device **10** uses algorithms to determine activity type, behavioral patterns and user habits based on collected data.

In one embodiment, the monitoring device **10** uses the accelerometer information to improve the heart rate monitor. As a non-limiting example, the monitoring device **10** detects

movement and speed. Addition of this data improves the accuracy of the heart rate monitor and corrects for any miscalculations in vibration, noise and skin color.

In one embodiment, velocity readouts and accelerometer data are used to measure when to sample heart rate. For example, if the monitoring device **10** registers zero velocity readout, the user is probably at rest or engaged in a passive activity. Thus, the monitoring device **10** knows not to sample heart rate. This results in conservation of time, energy and data storage.

User activity, performance and action can be based on the acceleration and angular velocity of the monitoring device **10**. In one embodiment, the monitoring device **10** has a feature where the monitoring device **10** authorizes third party interaction based on hand gesture, on previous interactions or patterns of behavior. As a non-limiting example, if one purchases a coke every day for the last two weeks, the monitoring device **10** can "orders" the person another one based on the prior history.

In one embodiment, the monitoring device **10** features near-by monitoring device **10** recognition that provides for other monitoring device **10** devices to be recognized within a particular vicinity and are able to share and transfer data between them. The monitoring device **10**'s data analysis and feedback can be based on current or previous sensor output. The monitoring device **10** can alert the user when to charge the monitoring device **10** and when it is the most convenient for the user.

In one embodiment, the monitoring device **10** provides feedback via color change. An outer shell of the monitoring device **10** can use visual feedback, including but not limited to pigment or color changes to indicate changes in user behavior or to prompt changes in user behavior. In one embodiment, the monitoring device **10** is flexible in shape. As a non-limiting example, if the user puts the monitoring device **10** over their hand it can expand or contract, morphing to change size and shape.

In one embodiment, the monitoring device **10** can have a sync feature for multiple bands at the same time.

In one embodiment, the monitoring device **10** has data transfer to an external device that can be included or not included in system **32**. Monitoring device **10** could be a data leaching device. For example, the user can relay information to someone else's device (intermediary device) to access Network Systems connected device.

In one embodiment, the monitoring device **10** can disable the recording of one or more sensors **14** based on location, acceleration (or lack thereof) and the like.

In one embodiment, the monitoring device **10** detects different types of transportation and activity based on sensor data. In one embodiment, monitoring device **10** can unlock doors or cars. The user can turn it on and off. As a non-limiting example, it can be turned off by having a capacitor switch on top and bottom and is placed in a way that one couldn't accidentally turn it off. As a non-limiting example, turning it off can be done by rotating the monitoring device **10** once.

In one embodiment, the monitoring device **10** recognizes the wearer based on biometric information, previous data, movement pattern, and the like. In one embodiment, the monitoring device **10** detects a new user based on an inability to match to user/usage patterns.

As non-limiting examples, a variety of different sensors **14** can be used such as, an altimeter, blood oxygen recognition, heart rate from wrist via sonar, Doppler, based on sound wave and movement, based on pressure, and the like.

A pressure sensor **14** can be placed on a circulatory vessel such as a vein to detect pulse.

With the monitoring device **10** of the present invention, mechanical actions of the user can be triggered, recognized and evaluated.

As a non-limiting example, with multiple users and wearable devices **10**, a separate monitoring device **10** ID is assigned to each of the users A, B AND C, and thereafter the assigned transmitter/monitor **14** generates user activity data and/or user tracking data. For purposes of this disclosure, monitoring data is defined to include data acquired during the process of monitoring or evaluating a predefined characteristic. The user activity data tracks data from the sensors **14** is transferred to the receivers **34** via the wireless connections **38** represented by a dashed line.

A Network System **101** of receivers **34** transfers the user activity and/or tracking data to system server **16** via connection **50**. System server **16** includes a processor **52** configured to process the user data in a known manner. For example, the processor **52** may convert raw user data acquired by the sensors **14** into more conveniently readable data.

As a non-limiting example, the display **42** can be implemented to graphically convey user information from system server **16** in a conveniently readable manner. As a non-limiting example, the user may be a cardiac patient with user monitoring data graphically conveyed as a conventional ECG plot comprising a sequence of P-waves, a QRS complexes and a T-waves. As another example, user tracking data may be graphically conveyed as an icon superimposed onto a map to indicate the user's relative location. Alarm **44** may be included in this embodiment.

In some embodiments, system **32** ID circuitry delivers a unique ID to the wearable device from database **18**. BLUETOOTH® chips can be coupled with other wearable devices **10** in the area. This data is then stored, as more fully explained in the following paragraph. The unique ID can be utilized for a variety of different applications including but not limited to payments, social networking and the like.

The ID circuitry of system **32** can include a number of system/components: unique ID storage, communication system, which reads and transmits the unique ID from the unique ID storage, battery **24** or power system that provides power to enable communication with the monitoring device **10**, a pathway system to route signals to through the circuitry, a cluster that crunches information, and a control system, to orchestrate the communication between different systems. All of these systems can be implemented in hardware, software or a combination thereof. Continuing with the telemetry system **32**, sensors **14** and sensing devices are disposed on wearable devices **10** worn by users. Data, such as movement, location, speed, acceleration, and the like, can be acquired, captured and provided to system **32**.

System **32** and an associated Network System **101** can include an identification reference, including user activity, performance and reference information for each individual sensor **14** and location.

The user activity, performance metrics, data and the like captured by system **32** can be recorded into standard relational databases SQL server, and/or other formats and can be exported in real-time.

In various embodiments, the monitoring device **10** and/or system **32** are fully sealed and have inductively charges. All communication is done wirelessly.

In one embodiment, there are no electrical contacts, physical contacts or connections with the monitoring device **10**. The monitoring device **10** is seamless. The telemetry

system **32** can include a microprocessor with CPU **20**, memory, interface electronics and conditioning electronics **33** configured to receive a signal from the sensors **14**. In one embodiment, all or a portion of the conditioning electronics **33** are at the monitoring device **10**.

In one embodiment, the CPU **20** includes a processor **52**, which can be a microprocessor, read only memory used to store instructions that the processor may fetch in executing its program, a random access memory (RAM) used by the processor **52** to store information and a master clock. The microprocessor **52** is controlled by the master clock that provides a master timing signal used to sequence the microprocessor **52** through its internal states in its execution of each processed instruction. In one embodiment, the microprocessor **52**, and especially the CPU **20**, is a low power device, such as CMOS, as is the necessary logic used to implement the processor design. The telemetry system **32** can store information about the user's activity in memory.

This memory may be external to the CPU **20** but can reside in the RAM. The memory may be nonvolatile such as battery backed RAM or electrically erasable programmable read only memory (EEPROM). Signals from the sensors **14** can be in communication with conditioning electronics **33** that with a filter **35**, with scale and can determine the presence of certain conditions. This conditioning essentially cleans the signal up for processing by CPU **20** and in some cases preprocesses the information. These signals are then passed to interface electronics, which converts the analog voltage or currents to binary ones and zeroes understood by the CPU **20**. The telemetry system **32** can also provide for intelligence in the signal processing, such as achieved by the CPU **20** in evaluating historical data.

In one embodiment, the actions of the user wearing the monitoring device **10** with the unique ID can be used for different activities and can have different classifications at system **32**.

The classification can be in response to the user's location, where the user spends it time, with which the user spends its time, determination of working relationships, family relationships, social relationships, and the like. These last few determinations can be based on the time of day, the types of interactions, comparisons of the amount of time with others, the time of day, a frequency of contact with others, the type of contact with others, the location and type of place where the user is at, and the like. These results are stored in database **18**.

In one embodiment, the user wearing the monitoring device **10** can access this information from any place where data is presented to the user, including but not limited to mobile devices, the WEB, applications program identifiers, and the like.

As a non-limiting example, the monitoring device **10** communicates with a base station at system **32**. The monitoring device **10** can intelligently switch between data transfer and charging based on sensor readout. The monitoring device **10** can represent data based on connected devices.

In one embodiment, the monitoring device **10** has the capability of providing recommendations, popularity of locations or activities based on acquired data from the user.

In one embodiment, the monitoring device **10** has the capability of introducing the user to other people or users based on their data and the user's data.

In one embodiment, the monitoring device **10** can determine emotion of the user.

In one embodiment, the monitoring device **10** uses incremental data transfer via BLUETOOTH® and the like. The

monitoring device 10 can transmit data through the inductive coupling for wireless charging. The user is also able to change the frequency of data transmission.

The monitoring device 10 can engage in intelligent switching between incremental and full syncing of data based on available communication routes. As a non-limiting example, this can be via cellular networks, WiFi, BLUETOOTH® and the like. In one embodiment, the monitoring device 10 has data storage. As a non-limiting example, storage of telemetry data on monitoring device 10 can be amounts up to about 16 mg.

In one embodiment, data transferred if it's in a selected proximity of a base station of system 32 or in proximity of an associated connected Network System 101. In one embodiment, the monitoring device 10 has a dynamic change of data capture frequency. The monitoring device 10 can be programmed to instantly change how often it samples any sensor 14 based upon the sensor data. Intelligent data sampling is based on sensor readout.

The monitoring device 10 can receive firmware updates via a base station 110 of system 32. In one embodiment, the monitoring device 10 presents analyzed data and feedback on a website. In one embodiment, the monitoring device 10's software is based on unique human movement. The monitoring device 10 is able to identify its wearer based on the unique patterns of movement, location check-ins and daily habits of the user.

In one embodiment, the app can be used on a mobile device, including but not limited to a smart phone and the like.

In one embodiment, a breakdown of recounting data that has been collecting is presented for analysis of that data. Observation or recommendations can be presented based on historical information and live information. The importance of the data can be based on past user behavior.

In one embodiment, the monitoring device 10 has artificial intelligence. A wearable device processor 54 implements logic resources that exist on monitoring device 10.

In one embodiment, monitoring device 10 engages in the routing of user information to third parties based on pre-defined rules, based on system 32 analyses.

In one embodiment, monitoring device 10 includes one or more processors 54 that implement intelligent algorithmic processing and transfer of information to third parties. Feedback can be provided to the end user that is based on visual, tactile, gesture information and the like.

The ID can be sent from the monitoring device 10 in a variety of different transmit modes, which may be provided as part of the firmware or software of an ID or sensor transmitter 14, and which may be utilized selectively during the operation of said sensor transmitter 14, may include "burst" transmit modes, wherein a burst of data information is transmitted, or "parcel" transmit modes, wherein timed data packets of data, which may, as desired, comprise partial data strings, are transmitted, and, if desired, repeated during time intervals. Further, the sensors 14 may have programmed therein diagnostic routines or other test modes which assist during manufacture and use, providing the operator with operational status and verification information on said sensor/transmitter 14, as needed. Referring to FIG. 4, system 32 includes data base 18 which contains the desired transmitter, sensor, 14 personality data, as well as, the address/device ID bits for each monitoring device 10.

In one embodiment, the initial programming of the monitoring device 10 for the ID, as well as optionally other personal information of the user, is done securely, as unau-

thorized future alteration of same thereafter can be utilized as a means of violating system integrity.

In one embodiment, an inductive field coil is used for programming the sensors 14 and ID of monitoring device 10.

As illustrated in FIG. 4, the monitoring device 10 can include a sensor 14 with an output that be received by an amplifier 56 and decoded by an I/O decoder 58 to determine I/O logic levels, as well as, both clock and data information 60. Many such methods are commonly available including ratio encoding, Manchester encoding, Non-Return to Zero (NRZ) encoding, or the like; alternatively, a UART type approach can be used. Once so converted, clock and data signals containing the information bits are passed to a memory 62. Any of these connections provides a logical link from the system's database 18 to the sensor 14, ID of the monitoring device 10, as shown in FIG. 5.

In one embodiment, illustrated in FIG. 5, the system 32 chooses the necessary programmable sensor functions and stores them into database 18. In one embodiment, in order to insure that an unauthorized user cannot connect into and program monitoring device 10 the following procedure may be used:

Both the sensor 14 and receiver 34 contain an identical, repeatable pseudo randomization algorithm in ROM or in ASIC logic.

Referring to FIG. 6, the algorithm is applied to outgoing programming data 64 from system 32 and produces a number of security/randomization bits 66 that can be appended to the outgoing programming message or message 68 and sent to a sensor 14.

Referring to FIG. 7 the sensor 14 likewise applies this pseudo randomization algorithm as the security/randomization bits 66 to the outgoing programming data, now forming the incoming programming data 70 to sensor 14 and produces a several bit result in the shift register 71. The scrambling algorithm is devised such that a small difference in the programming bit stream causes a great difference in the pseudo randomization result. As a non-limiting example, the present invention can use a 16 bit polynomial to produce this pseudo randomization.

Optionally, in one embodiment, before a sensor 14 accepts this programming, stored in an address and personality register 73, both the pseudo random code, stored in data in a shift register 75 from system 32 and a sensor 14, in a shift register 71 must match via a comparator ID, 77, indicating unauthorized acceptance use. In addition to insuring authorized access, this process also insures that the data itself is correct. The longer the polynomial sequence used, the greater the security.

In one embodiment, spread spectrum or other RF transmission is used and can include programming to determine that the frequency or spread spectrum code is unique to the area. If a spread spectrum code, system code, or frequency channel is found to be occupied at a future time of use. Re-programming of the monitoring device 10 is then done with a new, unused spread spectrum code or system code or frequency channel can be selected, or, in the alternative, CPU 20.

As illustrated in FIG. 5, step "E" would include, for example, the step of the sensor 14, inputting the programming message and saving a seed in memory 62; with the sensor 14 utilizing the seed to code digital data bits transmitted.

As illustrated in FIG. 8, the location of a monitoring device 10 with the ID and sensors 14 can be determined. As a non-limiting example, in one embodiment the monitoring

device **10** includes a sensor **14** that can provide a position signal having positioning data (e.g., raw GPD data or pseudo ranges) and the ID is transmitted from the monitoring device **10** to system server **16**. Server **16** receives the position signal and analyzes the signal to generate information representing the location of the monitoring device **10**. Server **16** transmits this location information to a client computer where the location of the monitoring device **10**, allowing a user to identify the location of the remote sensor **14**.

In one embodiment, the position signal transmitted by the remote sensor **14** can also include an emergency code. For example, in the event of an emergency, such as a medical emergency or otherwise, a user may press a "panic button" that can be on the monitoring device **10** or by use of a user's mobile device. Pressing the panic button may cause mobile device **74** to transmit an emergency signal to a cell site **76** where the emergency signal is relayed to server **16**. In response, server **16** can transmit Doppler information regarding in-view satellites, a fix command and a time trigger signal to the monitoring device **10**.

When the location of the monitoring device **10** has been determined, software running on server **16** configures server **16** such that a call or other signal is sent to a local emergency operator in the vicinity of remote sensor **14**. When the call or signal is received at the emergency operator station, the location of remote sensor **14** is transmitted and displayed. In some cases, where separate panic buttons are available for identifying medical, police, fire or other types of emergencies, the nature of the emergency is also displayed for the emergency operator. Based on this information, the emergency operator can initiate an emergency response by providing the location of remote sensor **14** to the required emergency service (police, fire department, ambulance service, etc.). In other embodiments, instead of or in addition to a position report for the remote sensor **14**, the emergency operator may also be provided with information which identifies an emergency response vehicle in close proximity to remote sensor **14**.

As illustrated in FIG. 9, a sensor **14** of the monitoring device **10** can include a SNAPSHOT GPS receiver **72**. As described above, sensor **14** uses information transmitted from separately located base station **110**, mobile devices, computers, and other devices, to assist in determining the position of the remote sensor **14**, as more fully disclosed in U.S. Pat. No. 6,661,372, incorporated herein by reference.

As non-limiting examples, and as illustrated in FIG. 10, the sensors **14** can be a thermal transducer **78**, an acoustic transducer **80**, and a magnetic transducer **82**. It will be appreciated that the present invention is not limited. The transducers **78**, **80**, and **82** in the monitoring device **10** can communicate with a microprocessor **84** also located in the monitoring device **10**. The monitoring device **10** can communicate with other devices via an RF transceiver **86**, an IRDA transceiver **88**, and/or an RF backscatter transceiver **90**. Each of the components in the monitoring device **10** receives power as necessary from the battery **24**, which may include the rechargeable battery.

The acoustic transducer **80** may include a microphone, a low-pass filter, a gain amplifier, and a threshold comparator. The acoustic transducer **80** may include an omnidirectional microphone, although any other suitable acoustic transducer device would suffice. The microphone may be a surface mount MEMS device that has a frequency range of 100 Hz to 10 kHz. A single MCP602 operational amplifier is used on the acoustic sensor to amplify and low-pass filter the acoustic signal from the microphone. Another operational amplifier is used to generate a voltage reference used for single

biasing and detection. The microphone output is biased to the midway point between the circuit supply voltage and ground to allow for both positive and negative signal swings. The biased signal is filtered with a second order low-pass Butterworth filter to remove upper frequency noise. It is then amplified with an adjustable gain that is controlled by a digital resistor potentiometer. This digital resistor operates on an I2C bus and is controlled by the microprocessor **84**. Lastly, the amplified acoustic signal is threshold detected against a static voltage to detect sufficiently large acoustic signals. The digital output of the threshold detector is connected to the microprocessor **84** for processing.

The magnetic transducer **82** can include a magnetic sensor integrated circuit, a differential instrumentation amplifier, a low-pass filter, two gain amplifiers, and a threshold detector. The magnetic transducer **82** may include an NVE AA002-02 GMR (giant magneto resistive) field sensor, although any suitable magnetic sensor would suffice. This sensor has a saturation field of 15 Oe, a linear range of 0 to 10.5 Oe, and a sensitivity of 3 mV/V/Oe. Two MCP602 CMOS operational amplifiers are used on the magnetic sensor to amplify and low-pass filter the analog output signal. An INA122UA instrumentation amplifier is used as a difference amplifier for the differential output from the magnetic sensor. The magnetic sensor IC can be based on Spintronics technology. Its output includes a differential voltage pair proportional to the detected magnetic field. The differential voltage pair is amplified and converted to a single voltage by the instrumentation amplifier. The AC-coupled signal is then amplified and filtered with a low-pass filter to remove upper frequency noise and boost the low-voltage signal output. The signal is amplified a second time by an adjustable gain controlled by a digital resistor similar to the acoustic sensor. Lastly, the amplified magnetic signal is threshold detected against a static voltage, to detect sufficiently large changes in magnetic fields. The digital output of the threshold detector can be connected to the microprocessor **84** for processing.

A DS 1803E-010 digitally controlled 10 kOhm variable resistor can be used in both the acoustic and magnetic sensor circuits. It is used to adjust the gain of one gain stage in each circuit. The digital resistor is controlled through an I2C interface. A LMV393IPWR comparator is also used in both the magnetic and acoustic sensor circuits for determining when a sufficiently strong sensor signal has been detected. It compares the analog sensor signal against the voltage reference and its output is tied to the microprocessor **84** for data collection.

The thermal transducer **78** may include a Burr Brown TMP100NA/250 12-bit digital temperature sensor, although any suitable thermal sensor would suffice. The digital temperature sensor has an operating range of -55 to +120.degree. C., an accuracy of 0.5.degree. C. and a maximum resolution of 0.0625.degree. C.

Even though it is a 12-bit sensor, suitable results are achieved with only 9-bit conversions with only the 8 most significant bits used. The sensor has an I2C interface and is normally kept in sleep mode for low power operation. When directed by the microprocessor **84**, the thermal transducer can perform a 9-bit temperature conversion in 75 milliseconds.

The RF transceiver **86** may include an RF Monolithic DR3000 transceiver, although any suitable transceiver or separate transmitter and receiver **34** would suffice. This transceiver **86** allows for both digital transmission and reception. The transceiver **86** can have an operating frequency of 916.5 MHz and is capable of baud rates between

2.4 kbps and 19.2 kbps. It can use OOK modulation and has an output power of 0.75 mW. It also can use digital inputs and outputs for direct connection with the microprocessor **84**. The transceiver **86** can use an antenna **92** (FIG. **11**) that may include a 17 mil thick plain steel electric guitar G-string cut to a length of 8.18 cm. It is used in a monopole over ground configuration and can require a matching circuit of one inductor and one capacitor. Alternatively, Frequency Shift Keying (FSK), Quadrature Phase Shift Keying (QPSK), or any other suitable modulation scheme may be utilized.

The IRDA transceiver **88** may include a Sharp GP2W0110YPS infrared transceiver, although any suitable IRDA compliant infrared transceiver would suffice. This transceiver **88** can be IRDA v1.2 compliant and in one embodiment has an operating range of 0.7 meters. In one embodiment, it is capable of 115.2 kbps data speeds.

The RF backscatter transmission device **90** may include circuitry available from Alien Technology (of Morgan Hill, Calif.) for receiving and transmitting signals via RF backscatter. Battery **24** may be a 3.6 volt ½ AA lithium battery with a capacity of 1.2 amp hours. The battery **24** can be a power source **24** that can include a Texas Instruments TPS76930DBVT voltage regulator to regulate the output signal to 3 volts and with a maximum current of 100 mA. The voltage regulator can include a LDO.

The RF backscatter transceiver **86** in the monitoring device **10** communicates with an RF backscatter reader **94** such as a class **3** reader from Alien Technology. The reader **94** transmits data to the backscatter transceiver **90** of the monitoring device **10** by broadcasting encoded RF pulses and receives data back from the transceiver **86** by continually broadcasting RF energy to the sensor **10** and monitoring the modulated RF reflections from the sensor **10**.

The RF backscatter transceiver **90** can include a printed circuit board (PCB) patch antenna for RF reception, and RF modulation, a Schotky diode detector circuit, a comparator circuit for signal decoding, and a logic circuit for wake-up. The logic circuit monitors the incoming data, and when an appropriate wake-up pattern is detected, it triggers the microprocessor **84** so that data reception can begin. In one embodiment, the reader **94** has an operating frequency between 2402 MHz and 2480 MHz, and uses frequency hopping in this band to reduce noise interference. A modulation method used by the reader **94** can be On-Off Keying (OOK). In one embodiment, the transmission power is 1 watt. The operation of the reader **94** may be controlled by an external computer (not shown) as directed by Labview software via a RS-232 serial link.

The RF transceiver **86** can communicate with an external RF transceiver **96** such as a DR3000 transceiver from Radio Monolithics, Inc. In one embodiment, it operates at 916.5 MHz, uses OOK modulation, has a communication range of 100 meters line of sight, and a baud rate of 19.2 kbps. The active RF antenna **92** can be a quarter-wavelength monopole made from a guitar G-string and appropriate matching circuitry. Two control lines from the microprocessor **84** can be used to select the mode of operation, choosing from transmit, receive, and sleep. The active RF receiver **34** consumes the most power in receive mode compared to the other two communication links.

FIG. **6** shows the relative positioning and shape of the active RF antenna **92** and the RF backscatter antenna **98**.

The IRDA transceiver **88** of the monitoring device **10** can communicate with an external IRDA transceiver **100** that may be identical to the IRDA transceiver **88**. Alternatively, the IRDA transceiver **100** can be one such as is provided in

most personal digital assistants (PDA) as well as many other consumer devices. The IRDA communication link follows the standard IRDA signal and coding protocol and is modeled after a standard UART interface. In one embodiment, the IRDA transceiver **88** is capable of data speeds less than 115.2 kbps, and may only have a range of 0.7 meters for transmission. One advantage of the IRDA communication link is that it does not require any of the RF spectrums for operation, but it typically does require line-of-sight communication.

When any one of the transceivers **86**, **88** and **90** on the monitoring device **10** detect the beginning of valid data on their respective communication link, all other transceivers are disabled, thereby preventing the corruption of incoming data with the noise or partial data packets on the other communication links. However, if the data on the active transceiver proves to be erroneous, the other transceivers will be re-enabled if appropriate to allow normal operation to continue. If the data received by the active transceiver is valid, however, the other transceivers will remain disabled for several hundred milliseconds longer in the high probability that the next data packet will be transmitted on the same communication link. If, after this extended delay, no additional packets are received, then the other transceivers will be re-enabled as appropriate.

In one embodiment, the active RF protocol has no wake-up or synchronization packets, and the packets sent to and from the sensor are identical. In one embodiment, the format of an active RF packet is shown in FIG. **2**. It can include a preamble to reset and spin-up the state machine of the RF receiver **34** and to properly bias the receiver's **34** data slicer/threshold detector for optimum noise rejection and signal regeneration, two framing bits to indicate the beginning and end of the data bytes, and the data bytes themselves.

Furthermore, the encoding scheme for the three symbols is shown in FIG. **12**. The entire packet is DC balanced to maintain an optimal level on the data slicer/threshold detector and the receiver **34**. Data is sent most significant bit first.

The IRDA communication link can follow the standard IRDA protocol for bit encoding and UART protocol for byte transmission. Packets transmitted on the IRDA link can contain no preamble or framing bits, but they do have a header that contains two bytes. The first byte is an ASCII "I" which denotes the beginning of a valid IRDA packet. The second byte equals the number of preceding bytes in the packet. This value is used by the receiver **34** to determine when the entire packet has been received and processing of information can begin. The packet structure is shown in FIG. **13** and the IRDA/UART encoding scheme is shown in FIG. **14**.

The data bytes contained in a packet transmitted to the sensor **10** through any of the communication links conform to a packet format. The CMD section of a packet is a single byte that identifies the type of packet being sent. The CMD byte appears above the beginning and end of the packet and the two must be identical. The reason for including the redundant byte is to further eliminate the chance of a packet's CMD identifier being corrupted at the receiver **34**, even if the CHECKSUM is correct.

The PAYLOAD contains all of the data that must be sent to, or returned from, the sensor. The PAYLOAD is broken down into individual bytes with the overall number of bytes and their content dependent on the type of packet being sent.

The CHECKSUM is a 16-bit CRC that is performed on all bytes in the data packet excluding the end CMD byte in

packets generated by the external device. The CHECKSUM is sent the most significant byte first.

The transceivers **86**, **88** and **90** may be required to communicate over a greater distance than do the components described herein. Upgrading these components to be suitable for longer distance transmission is considered to be within the spirit of this invention. The type of transducer is not limited to the specific transducer types described herein. In addition, the logic described herein for arbitrating between which communication device to use to communicate with the outside world and which sensor data to provide at what time is but one possible approach to arbitration logic within such a remote sensor **10**.

FIG. **15** illustrates one embodiment of an exemplary Network System **101** that can be used with the present invention. As shown in FIG. **15** a wireless packet data service Network System **102** that can be utilized with the monitoring device **10**. An enterprise Network System **104**, which may be a packet-switched network, can include one or more geographic sites and be organized as a local area network (LAN), wide area network (WAN) or metropolitan area network (MAN), and the like. One or more application servers **106-1** through **106-N** can be included and disposed as part of the enterprise network **104** are operable to provide or effectuate a host of internal and external services such as email, video mail, Network Systems **101** access, corporate data access, messaging, calendaring and scheduling, information management, and the like using the unique IDs of the wearable devices **10**. The monitoring device **10** can be in communication with a variety of personal information devices other than the monitoring device **10**, including but not limited to, computers, laptop computers, mobile devices, and the like.

Additionally, system server **16** may be interfaced with the enterprise Network System **104** to access or effectuate any of the services from a remote location using a monitoring device **10**. A secure communication link with end-to-end encryption may be established that is mediated through an external IP network, i.e., a public packet-switched network such as Network Systems **108**, as well as the wireless packet data service Network System **102** operable with a monitoring device **10** via suitable wireless Network System **101** infrastructure that includes a base station (BS) **110**. In one embodiment, a trusted relay Network System **101** **112** may be disposed between Network Systems **108** and the infrastructure of wireless packet data service Network System **102**.

In another embodiment, the infrastructure of the trusted relay network **112** may be integrated with the wireless packet data service network **102**, and the functionality of the relay infrastructure can be consolidated as a separate layer within a "one-network" environment. Additionally, as non-limiting examples, monitoring device **10** may be capable of receiving and sending messages, web browsing, interfacing with corporate application servers, and the like, regardless of the relationship between the networks **102** and **112**. Accordingly, a "network node" may include both relay functionality and wireless network infrastructure functionality in some exemplary implementations.

In one embodiment, the wireless packet data service Network System **102** is implemented in any known or heretofore unknown communications technologies and network protocols, as long as a packet-switched data service is available therein for transmitting packetized information. For instance, the wireless packet data service Network System **102** may be comprised of a General Packet Radio Service (GPRS) network that provides a packet radio access

for mobile devices using the cellular infrastructure of a Global System for Mobile Communications (GSM)-based carrier network. In other implementations, the wireless packet data service Network System **102** may comprise an Enhanced Data Rates for GSM Evolution (EDGE) network, an Integrated Digital Enhanced Network (IDEN), a Code Division Multiple Access (CDMA) network, a Universal Mobile Telecommunications System (UMTS) network, or any 3rd Generation (3G) network.

Referring now to FIGS. **16(a)** through **16(d)**, in one embodiment, the monitoring device **10** is in communication with an interaction engine **120** that can be at a mobile device **74** or system **32**. The interface engine can be a software application running on mobile device **74** associated with another party, including but not limited to a merchant, an associate, a friend, and the like. The enables the monitoring device **10** user and a merchant to interact with a transaction engine **114** to and enter into a financial transaction for the transfer of funds from a third party payment system **116** that is independent of the monitoring device **10** user's financial account **118**, and complete a transaction. It should be noted that the payment system **116** can be affiliated with the financial account **118** or can be a separate and non-affiliated with the financial account **118**. The interaction engine **120** can take input of information related to a transfer of funds from the monitoring device **10** users' financial accounts **118** as input to the transaction engine **114** to initiate and complete a financial transaction, including but not limited the purchase and payment of goods and services. In one embodiment, this input to the interaction engine **114** can include, an amount of a transaction, additional items related to the transaction, authorization and/or signature of the monitoring device **10** users.

In one embodiment, the mobile device **74** receives information from the monitoring device **10**, e.g., the unique ID.

The interaction engine **120** can also present products or services provided by a merchant to directly to or through system **32** to the monitoring device **10** user. In one embodiment, the monitoring device **10** users can use the mobile device **74**, the WEB, and the like, to view, text, pictures, audio, and videos, and browse through the products and services on the mobile device **74**, personal computers, other communication devices, the WEB, and anything that is BLUETOOTH®, anything associated with Network Systems **101**, and the like.

In one embodiment, the transaction engine **114**, which can be at the mobile device **74**, or external to the mobile device **74**, including but not limited to monitoring device **10** and the like, takes decoded financial transaction card information from a decoding engine **122**, internal or external to the mobile device **74**, and a transaction amount from an interaction engine **120**, also internal or external to the mobile device. The transaction engine **114** then contacts the payment service **116**, and or the monitoring device **10** users' financial account **118**, such as an acquiring bank that handles such authorization request, directly or through the payment system **116**, which may then communicate with a financial transaction card issuing bank to either authorize or deny the transaction. The payment system **116** can include a user database, a transaction database, a product database, and the like. These databases can also be external to payment system **116**. If the third party authorizes the transaction, then the transaction engine **114** transfers funds deducted from the account of the monitoring device **10** user, or the payment system **116** can already have those funds readily available, to an account of a third party which can be another monitoring device **10** user, a merchant, and the like, and provides

transaction or transfer of fund results to the interaction engine 120 for presentation to a third party.

In one embodiment, the transaction engine 114 does not have the financial account or financial card information of the monitoring device 10 user that is doing the transfer. In some embodiments, the transaction engine 114 keeps only selected information of the monitoring device 10 user's financial accounts 118 or financial transaction cards.

In one embodiment, the wearable device communicates directly, without mobile device 74, with the payment system 116 and/or the user's financial account 118 or associated financial institution.

In one embodiment, the transaction engine 114 communicates and interacts with the financial account 118 or associated financial institution directly or through the payment system 116, through a user database, product database, and transaction database, which databases can be separate from or included in the payment system 116, over a Network System 101. The Network System 101 can be a communication network, as recited above, and can be based on well-known communication protocols, including but not limited to, a TCP/IP protocol.

With social networking applications, the monitoring device 10, with its unique ID, is an ID device. Information from the monitoring device 10 relating to social networking, and the like, communicates with system 32. In this manner, the wearable devices 10, with their own unique ID's, can be recognized. This can occur at different locations, close by, distanced, and notifications can be sent to the different users wearing a monitoring device 10 for a variety of social networking and other communication applications. Additionally, monitoring device 10, with its sensors 14 and ID can communicate directly to social networking sites, Network System 101 Systems, cloud services, and the like.

In one embodiment, with the current permissions given by the wearable device users, marketers, companies or individuals who wish can deliver advertisement monitoring device 10 users. More particularly, system 32 can be configured to allow marketers, and the like, to deliver advertisements to consumers to buy products or services offered by the marketer. Advertisements can also be sent to monitoring device 10 users with the appropriate permissions. In one embodiment, system 32 maintains the anonymity of the monitoring device 10 users while allowing the marketers to have their advertisements delivered to those that fall within their defined market segment.

In one embodiment, the wearable device ID of a user provides a method of identifying and contacting users of a social networking service. The method may include the steps of signing up for a social networking service, displaying the wearable device ID, viewing another person's unique wearable device ID displayed by another user, and finding that user on a social networking service website by searching for the user using the wearable device ID viewed.

System 32 may serve a number of purposes without straying from the scope of the present invention. For example, the social networking service may allow monitoring device 10 users to engage in non-romantic relationships, keep in touch with acquaintances, friends and family, professional business relationships, and romantic relationships, may allow communication between wearable device users on a message board or Network Systems 101 forum, and may allow users to follow up on missed-connections that otherwise would not have been realized.

In one embodiment, the step of providing personal information to start an account with system 10 for different applications may be performed by a purchasing or acquiring

a monitoring device 10, with a unique assigned ID, and the user can fill in an online form. This form may require users to fill in fields on the form. These fields may include: first and last name, email address, a desired password, phone number, gender, birth date, address, geographic region, education information, employment information, interests, relationship information and interests, family information, religious views, ethnicity, physical features including hair color, eye color, measurements, and the like, type of relationship being sought, living situation, answers to quiz questions, and a personal description about interesting personality traits, among other things. In addition, users may upload one or a plurality of photographs for other users to view, or for users to store the photo or photos on the server of system 32.

In another embodiment the step of providing personal information to start an account with system 32 by monitoring device 10 users may be performed automatically. In this embodiment, system 32 can access a social networking service, access, via computer, contact lists or other sources of information that may include the type of information listed above.

In a further embodiment, the step of providing personal information to system 32 can be automated by importing data containing the personal information required from other social networking services including but not limited to Facebook®, LinkedIn®, MySpace®, Match.com®, EHarmony.com®, a user's email or contact list, v-card, and the like.

The unique wearable device ID may allow the user to be searched and identified by other users and potential users. Also, a computer generated email address may be provided to a user. In one embodiment, this email address may be the user's user ID followed by "@iseenya.com." In another embodiment, the email address may be the user's user ID directed to another domain name.

In one embodiment, a computer generated personal page may be provided to a monitoring device 10 user. The personal page may utilize a computer to automatically import the information provided when signing up with system 32 or a social networking service. In another embodiment, the information and formatting of the personal page can be customizable.

When mobile device 74 is used, it communicates with one or more sensors 14 that are at the monitoring device 10, as more fully herein. The mobile device can 74 pull from system 32 updates from the server 16, including but not limited to settings such as alarms, name of the wearable device wearer using the ID, a sensor 14 and the like. Sensors 14 at the monitoring device 10 can send streams of information, both encrypted and non-encrypted to the mobile device and then to the server at system 32. Server 16 sends encrypted, and can also send non-encrypted information, to mobile device 74. Processing of this information can be achieved at the mobile device 74, and/or server 16. Mobile device 74 can receive raw sensor information from the monitoring device 10. This information can be compressed as well as non-compressed. A compression algorithm, at the wearable device and/or mobile device 74 or system 32, can be used in order to minimize the amount of information that server 16 sends. System 32 can include additional encryption and/or decryption systems.

Referring now to FIG. 17, a social network circle/group 124 (hereinafter "SNET circle") comprising social devices 126, including monitoring device 10, is shown. Beyond traditional social networking features and services, a SNET circle 124 and associated social devices 124 according to

various embodiments of the invention include numerous novel features and attributes as described more fully below with general reference to the illustration. Monitoring device 10 can utilize network 101 for communication with the SNET circle, as well as with other social networking sites, or through system 32.

Briefly, membership in the SNET circle 124 may comprise docked and undocked social devices 124 and human SNET circle members [104] 128, as well as proxies thereof. Further, SNET circle 124 nodes may include device services and software (e.g., applications) of various types participating as members. By way of example, SNET circle members might include artificial intelligence agents/social robots 130, SNET security device(s) 132, appliances, vehicles and service providers 134, common or authorized members/functionality of other SNET circles 124, and the like. Further, access to specific content and resources of a SNET circle 124 may be shared with members of additional SNET(s) 124, including remote or web-based applications. Such access can be conditioned on acceptable profiling and association data. Similarly, social devices or individuals may be granted temporary or ad hoc memberships, with or without restricted access.

In the illustrated embodiment, formation, maintenance and operation of SNET circle 124 is performed by stand-alone or distributed SNET processing circuitry and software 136. It is noted that the "SNET processing circuitry" may comprise hardware, software, applications, or various combinations thereof, and be configurable to support various functionalities disclosed herein. Further, the SNET processing circuitry 136 may be included in a standalone server, server farm, cloud-based resources, Network System 101, system 32 and/or the various types of devices described below, and incorporate authentication and security functionality 138. In addition, specialized middleware may also be utilized by SNETs according to the invention, including standardized middleware with an associated certification process. Interactions and interdependencies within the SNET circle 124 may involve one or more of a social device association/control module 140, a SNET circle member profiling module 142, and an adaptive resource allocation and arbitration module 144 as described more fully below.

Distribution of internal and external SNET content/media 146 can be accomplished in a variety of ways in accordance with various embodiments of the invention. For example, media distribution may involve an adaptive or parallel Network System 101 routing infrastructure involving a wide variety of communication protocols and wired and/or wireless communications channels. SNET content/media 146 may comprise, for example, various user-driven (advertising) channels, pictures, videos, links, online text, etc. Access to such content, as well as communications with and remote access to social devices 124 of the SNET circle 124, may occur over a Network Systems backbone 148, cellular communication system, WAN, LAN, and the like.

FIG. 18 illustrates an embodiment of a social group 150 comprising a variety of members in accordance with the present invention that can communicate through their wearable devices 10 and other devices, including but not limited to mobile devices 74. In this embodiment, membership in the social group 150 may include a variety of novel social system members [204] 152 functioning in various capacities within the social group 150. As will be understood, certain of the social system members 152 may support direct or indirect associations between the social group 150 and human members/non-members and users 154.

In the illustrated embodiment, social system members (or nodes) 152 include one or more local or remote servers and server clusters that provide a support infrastructure for social group functionality and member operations (routing, data storage, services, etc.). Communications within the social group and with non-members may occur via dedicated or multi-function communication path devices.

Social system members 152 further include devices configured to operate as nodes within the social group 150. Social functionality in such devices and other social system members 152 can be implemented through various means. For example, a device may have integral hardware/firmware/software to support social group access and member operations. Alternatively, a general purpose device 152a may include social code that enables participation in the social group 150. In a further embodiment, a device 152b designed to include social functionality may participate in the social group 150 through a combination of non-social code and a social shim layer or driver wrapper. In yet another embodiment, a member device 152c having a social design may utilize additional social code, including code specific to a social group 150.

Participation in the social group 150 is supported through functionality that includes automated and member-triggered membership invitations and processing (membership management) 156. More particularly, membership management 156 may function to invite prospective members to participate in the social group 150 through automatic, automated and member-triggered processes. For example, membership management 156 might be configured by a human user 154 to establish a social group 150 by automatically inviting/accepting social system members having certain characteristics (such as devices owned or controlled by the user or acquaintances of the user).

Processing of accepted invitations and unsolicited requests to join the social group 150 may be conditioned upon input or authorization from an existing social system member(s) 152 or human user(s) 154 (e.g., through a user interface). Similarly, membership management 156 may be configured to generate automated suggestions regarding which prospective members receive an invitation. Various other approaches, such as those described herein, can be used to establish membership in accordance with the invention.

Access to and visibility of resources of a social group 150, including services and data, may be managed through general and member class-specific access configurations 158. For example, if membership in the social group 150 includes family members and associated devices, a uniform access configuration (or separate device and human configurations) could be applied across the class in an automatic or automated manner. In other embodiments, access control and constraints are imposed on a per-member basis.

The social group 150 may offer a wide variety of member services 162, including both internal and external services accessible by social system members 152. By way of example, the social group 150 may offer email or other communication services between full members and/or authorized guest members and visitors. As with other resources of the social group 150, access control and constraints on member services 162 may be applied to individual members or classes of members.

FIG. 19 is a functional block diagram illustrating a social network (SNET) infrastructure 164, as more fully described and disclosed in EP 2582116, fully incorporated herein by reference.

In one embodiment, illustrated in FIG. 20, wearable devices 10 are in communication with a distributed computer network 166 that can include networks 102, 104, 112, coupled to Network Systems 108 and system 32 via a plurality of communication links 168. Communication network 166 provides a mechanism for communication with system 16, monitoring device 10, social media networks, mobile devices 74, payment systems, 116, the engines 114, 120, 122, components of system 16, and with all third parties, as described above.

The communication network 166 may itself be comprised of many interconnected computer systems and communication links. Communication links 168 may be hardwire links, optical links, satellite or other wireless communications links, wave propagation links, or any other mechanisms for communication of information. Various communication protocols may be used to facilitate communication between the various systems shown in FIG. 20. These communication protocols may include TCP/IP, HTTP protocols, wireless application protocol (WAP), vendor-specific protocols, customized protocols, and others.

While in one embodiment, communication network 166 is the Network System 101, in other embodiments, communication network 166 may be any suitable communication network 166 including a local area network (LAN), a wide area network (WAN), a wireless network, an intranet, a private network, a public network, a switched network, and combinations of these, and the like.

System 32 is responsible for receiving information requests from wearable devices 10, third parties, and the like, performing processing required satisfying the requests, and for forwarding the results corresponding to the requests backing to the requesting monitoring device 10 and other systems. The processing required to satisfy the request may be performed by server 16 or may alternatively be delegated to other servers connected to communication network 166.

FIG. 21 is a simplified functional block diagram of a portion of a wireless communication device in accordance with an embodiment of the present invention. Monitoring device 10 characterizes available networks to determine current network information, and may select one of the available networks based on the current network information and at least one of user preferences, application requirements and system information.

Monitoring device 10 may include one or more of several wireless interfaces to allow communication over wireless links with various communication networks. The wireless interfaces may include a packet wireless interface, such as GSM/GPRS interface 302 for communicating with packet wireless communication systems such as Global System for Mobile Communications (GSM) or General Packet Radio Service (GPRS) systems. The wireless interfaces may also include a digital mobile wireless interface such as Wideband Code Division Multiple Access (WCDMA) wireless interface 304. The wireless interfaces may also include wireless local area network (LAN) interface 306 for communicating in accordance with wireless LAN standards such as IEEE 802.11(a) and 802.11(b). The wireless interfaces may also include a short-range wireless interface such as BLUETOOTH® interface 308 for communicating with PC's, mobile phones and other portable devices in accordance with a short range digital communication protocol such as BLUETOOTH®. BLUETOOTH® wireless technology is a de facto standard, as well as a specification for small-form factor, low-cost, short range wireless links between mobile PCs, mobile phones and other portable devices. The wireless interfaces may also include an ultra-wideband (UWB) inter-

faces where no carrier is used. Monitoring device 10 may also include other wireless interfaces 309, which may, for example, be an ultra-wideband (UWB) interface which use no carrier, an analogue RF interface or an optical interface. Although monitoring device 100 is illustrated with several interfaces 302-309, nothing requires that monitoring device 100 include all interfaces.

In one embodiment of the present invention, one or more of the wireless interfaces may include software wireless interfaces or modules. In this embodiment, a software wireless interface may be a software wireless configurable with software to allow the wireless interface to be used/reused for different wireless links. For example, rather than a wireless interface having separate hardware for different communications (e.g., WCDMA and 802.11) packaged in one interface, a software wireless interface may have components configured or configurable to adopt the characteristics of the different communication requirements.

The wireless interfaces provide the RF or optical front-end functionality for communicating over a wireless link with a selected communication network. The wireless interfaces receive digital signals from multi-protocol wireless controller 310, and may modulate the signals on a suitable carrier frequency. The wireless interfaces also may demodulate signals received from antennas 324 and send a digital signal to wireless controller 310. In the case of UWB communications, modulation and demodulation to and from a carrier frequency may not be performed. Wireless controller 310 configures the information in accordance with an appropriate protocol for the communication link.

The wireless interfaces are illustrated as functionally separate units for ease in understanding the present invention, however any one or more may be combined as a single unit. Furthermore, although wireless controller 310 is illustrated as a separate functional element from the wireless interfaces, some of the functionality of wireless controller 310 may be performed by the wireless interfaces. For example, some processing specific to a particular protocol may be performed by a wireless interface. In accordance with one embodiment, wireless interfaces may be added or removed from monitoring device 10, and monitoring device 10 may include slots adapted to receive additional wireless interfaces. In accordance with another embodiment, one or more wireless interfaces may be fabricated along with controller 310 as a separate module, circuit board or add-on card for use in monitoring device 10.

Multi-protocol wireless controller 310 may be comprised of one or more processors configured with firmware and software to interface with wireless connectivity assistant 312 and system processor 320. Based on instructions and control signals from wireless connectivity assistant 312, wireless controller 310 utilizes wireless interfaces to characterize available networks and determine current network and service information. Current network and service information for an available network may include the services available (e.g., data, voice and the like), protocol requirements (e.g., IEEE 802.11(a)/(b), TCP/IP, IPSec), quality of service (e.g., average bit-rate, packet latency and bit-error-rate), bit-rates available for a particular protocol, network congestion, cost of a particular service, power consumption, location information (e.g., distance to receiver) and available security (e.g., virtual private network (VPN) capability, encryption type, encryption level). Bit-rate, as used herein may include a nominal bit-rate (i.e., the available bit-rate), an instantaneous bit-rate (i.e., the number of bits transmitted in the time of a packet), an average bit-rate (i.e., judging the number of packets to be transmitted or retransmitted over a period of

time), or effective bit-rate (a bit-rate that factors in other factors such as dropped packets).

Controller **310** may also query a service when multiple services are hosted by a network. For example, the same network may provide voice service, internet access, data service without internet access, a premium data service with better quality of service, subscription access, a public access service with a fee per use, a licensed access service for client corporations, etc. Controller **310** may query both the network and the service to determine the network and service characteristics. Some services may have characteristics such as quality of service guarantees such that for some links, the quality of service may be function of factors such as network congestion, link quality, etc. Guarantees for quality of service may be associated with higher costs and an allocation of greater network assets, such as additional bandwidth.

In characterizing the available communication networks and/or services, wireless controller **310** may utilize one or more of the wireless interfaces to monitor communications (e.g., traffic and signals) from one of the available communication networks. In this embodiment, the monitored communications may be used to identify available communication networks and/or services as well as used to determine how busy a particular network and/or service is and to help identify available channels or available bandwidth for the particular network and/or service.

Wireless controller **310** may also interrogate an available communication network and/or service to determine current network information and network characteristics. For example, wireless controller **310** may cause one or more of the wireless interfaces to send an interrogation signal requesting network characteristics and current network information. Interrogation may include requests for information as well as requests for service. In a request for service, a connection may be established to ascertain information and/or have a back-up link in case an active link is dropped inadvertently. In one embodiment, the power required to maintain a back-up link may be considered.

In one embodiment, wireless controller **310** may use geographic location information to determine the characteristics of available communication networks. For example, monitoring device **10** may have the characteristics of various communication networks available for various geographic locations stored in a memory. The geographic location of communication monitoring device **10** may be calculated and the characteristics of the available communication may be determined. A global positioning system (GPS) receiver (not shown) may be used to determine the geographic location of monitoring device **10**, or alternatively, signals from transmitters of one or more of the communication networks may be used to determine location (e.g., by triangulation). Additionally, location information may be used to determine proximity to network transmitters/receivers to determine some of characteristics that may affect communications. For example, a greater distance to a network's transmitter/receiver may require more transmission power by monitoring device **10**, and/or may result in a lower signal-to-noise ratio or higher bit-error-rate.

In some situations, communication links may exist within the same frequency band (e.g., BLUETOOTH®, 802.11b and Home-RF). In these situation, controller **310** may determine how much a link is degraded due to the presence of a competing system in the same frequency band providing more complete information on the available communication options. For example, although the controller may identify an 802.11b system, it may be unusable due to a close proximity of a BLUETOOTH® system. Alternatively, the

802.11b system may be utilized, for example, when the BLUETOOTH® system is not being used or is in a "sleep" mode.

The network characteristics and current network information is accumulated by controller **310** for use by wireless connectivity assistant **312**. Wireless controller **310** may store current network information and characteristics for the available networks and/or services in storage element **311**. Wireless connectivity assistant **312** may be a software agent running on monitoring device **10** (e.g., on system processor **320**) to interface between applications and the wireless interfaces. Wireless connectivity assistant **312** may select one of the available networks for communicating based on the current network information and characteristics of the available networks and/or services stored in element **311**, application requirements stored in element **314**, user preferences stored in element **316**, and system information stored in element **318**. Elements **311**, **314**, **316** and **318** are illustrated as separate elements to facilitate the understanding of the invention; however one or more physical storage locations accessible by wireless connectivity assistant **312** may be utilized.

Application requirements stored in element **314** are the requirements a particular software application may require for communicating with a network, and may include requirements for communicating over a wireless link. Application requirements may include, for example, bit-rate requirements, quality of service requirements, connectivity continuity requirements and privacy/security requirements. Application requirements may also include latency and bit-rate information for a particular applications. For example, voice communication may require lower latency and a lower bit-rate that video conferencing which may require a higher bit-rate and a higher latency. Video playback, on the other hand, may be more tolerant on latency. Applications may include software for email communications, video conferencing, data transfer, internet access, audio transfer, teleconferencing and voice conversations.

System information stored in element **318** includes information about the elements of monitoring device **10** that are relevant to network communications. In general, system information may include system requirements as well as system constraints as well as other system related information. For example, system information may include battery/power characteristics, video display characteristics, processing abilities and processing speed, privacy requirements, camera resolution, and audio characteristics (e.g., speaker and/or headphone quality). Among other things, system information may be used by connectivity assistant **312** to help select an available communication network, service and protocol for communicating. For example, video quality in excess of what the video display is capable of displaying (or may be configured to display) need not be obtained, and therefore a higher bit-error rate or lower signal-to-noise ratio may be acceptable. System information may also, for example, include a window size for which a video may run allowing connectivity assistant to select lower bit-rates when the window size is small.

User preferences stored in element **316** may include a user's preferred communication carrier, quality preferences, power constraints, and privacy preferences. The user's quality preferences may include different quality of service tolerances and/or preferences for different types of communications and may vary depending on the particular application. For example, the user may prefer a more stable lower-quality video over a less stable higher-quality video; the user may prefer that lower power communications be

selected if he/she relies heavily on battery power; or the user may prefer lower cost communications or a particular carrier or service provider for certain types of communications. User preferences may, for example, indicate that when the battery is low, the user desires communication links requiring lower power or that links with increased bit-error-rates are acceptable. In one embodiment, user preferences may be stored in a memory element such as a smart card or token which may be inserted into monitoring device 10. User preferences may be input by user through I/O 322. Wireless connectivity assistant 312 pulls together the user preferences, application requirements, and system information to make an intelligent selection among the available communication networks. Desirably, wireless connectivity assistant 312 operates without user intervention providing the user with a more gratifying wireless communication experience.

In accordance with one embodiment, controller 310 interprets commands from applications and may switch between wireless links of various networks in response to changing conditions (e.g., link degradation, increased network congestion) or changing application requirements (e.g., a new or current application requires additional bandwidth). Controller 310 also may maintain one or more wireless links with a network and permits the simultaneous communication with several networks with concurrently running applications. Accordingly, wireless monitoring device 10 need not be dependent on one wireless link with any one network.

In one embodiment where the wireless device is a multimedia device, such as a video camera, for example, with limited storage capability, the video data may be sent to a remote location having additional storage capacity, such as the user's home. In this embodiment, the multimedia device may include the wireless capabilities described herein or may be coupled with a wireless communication device.

FIG. 22 is a flow chart of an intelligent network selection and communication procedure in accordance with an embodiment of the present invention. Procedure 400 may be performed by monitoring device 10 or may be performed by another wireless communication device suitably configured. Although the individual operations of procedure 400 are illustrated and described as separate operations, it should be noted that one or more of the individual operations may be performed concurrently. Further, nothing necessarily requires that the operations be performed in the order illustrated. Procedure 400 characterizes available networks and/or services to determine current network information and selects one of the available networks based on the current network and service information, and at least one of user preferences, application requirements and system information.

Operation 402 characterizes the available networks and/or services to determine network characteristics and current network and service information. Operation 402 may utilize traffic analysis information 404, location information 406, interrogation information 408 and current connection information 410. Operation 402 may be performed, for example, by multi-channel wireless controller 310 (FIG. 21) described previously.

Operation 412 may select an available network based on the network characteristics and current network and service information obtained in operation 402, and at least one of user preferences 414, application requirements 416 and system information 418. Operation 412 may be performed by wireless connectivity assistant 312 (FIG. 1). User preferences 414 may correspond with user preferences stored in element 316 (FIG. 21), application requirements 416 may correspond with application requirements stored in element

314 (FIG. 21) and system information 418 may correspond with system information stored in element 318 (FIG. 21).

Operation 420 initiates a communication session with the selected available communication network and services, and operation 422 communicates in accordance with the application. Operation 424 monitors current communication conditions and may select another communication link or another communication network and/or services as appropriate based on, for example, user preferences, application requirements and system information.

The foregoing description of various embodiments of the claimed subject matter has been provided for the purposes of illustration and description. It is not intended to be exhaustive or to limit the claimed subject matter to the precise forms disclosed. Many modifications and variations will be apparent to the practitioner skilled in the art. Particularly, while the concept "component" is used in the embodiments of the systems and methods described above, it will be evident that such concept can be interchangeably used with equivalent concepts such as, class, method, type, interface, module, object model, and other suitable concepts. Embodiments were chosen and described in order to best describe the principles of the invention and its practical application, thereby enabling others skilled in the relevant art to understand the claimed subject matter, the various embodiments and with various modifications that are suited to the particular use contemplated.

What is claimed is:

1. A user monitoring device system, comprising:

a user monitoring device that includes a microphone and one or more sensors to determine air quality, sound level/quality, light quality or ambient temperature near the user, a motion detection device included in the user monitoring device configured to detect a user's movement information, the motion detection device and the monitoring system configured to assist to determine user sleep monitoring, sleep information and sleep behavior information, the microphone configured to record user movement sounds detected by the motion detection device, the motion detection device configured to cause the microphone to stop recording user movement sounds when the movement sounds are not directed to sleep monitoring, sleep information and sleep behavior information; and

a telemetry system in communication with the motion detection device and the monitoring device, the telemetry system configured to assist to determine user sleep monitoring, sleep information and sleep behavior information; that can be stored in the database.

2. The system of claim 1, further comprising: a unique user ID.

3. The system of claim 2, further comprising:

ID circuitry, the ID circuitry including ID storage, a communication system that reads and transmits the unique ID from an ID storage.

4. The system of claim 1, further comprising:

a feedback control system or subsystem at the telemetry system.

5. The system of claim 4, wherein the feedback control system or subsystem is at the monitoring device.

6. The system of claim 4, wherein the feedback control system or subsystem is a standalone.

7. The system of claim 4, wherein the monitoring device in operate communicates the feedback signal or alert to the user.

31

8. The system of claim 4, further comprising:  
a closed-loop system that provides control data to the monitoring device.
9. The system of claim 1, wherein the device is a mobile device.
10. The system of claim 1, wherein the telemetry system in operation compares a measured sensor signal from a sensor to a threshold level.
11. The system of claim 1, wherein the motion detection device produces motion detection that is partially reflected by the person's skin and then penetrates to an internal organ where it is partially reflected from those organs and is then detected at a detector.
12. The system of claim 11, wherein a displacement of the internal organ and the person's movement are detected at the detector.
13. The system of claim 1, wherein the motion detection device has one antenna.
14. The system of claim 1, wherein the motion detection device has at least two antennas.
15. The system of claim 1, wherein the motion detection device is configured to separate a movement of more than one person or animals in a room.
16. The system of claim 15, wherein the motion detection device is configured to separate movement of more than one

32

- person or animals in the room with multiple receiving antennas or multiple motion detection emitters.
17. The system of claim 15, wherein the motion detection device separates the movement of more than one person or animals in the room with multiple receiving antennas and or multiple motion detection emitters on a single device by first determining a phase angle between two or more receivers.
18. The system of claim 15, wherein one or more transmitters and one or more receivers are used to determine a location of a person, animal or item.
19. The system of claim 15, wherein the person, item, or animal is located via motion detection with a passive retroreflective tag or with an active beacon which responds to an emitted motion detection signal.
20. The system of claim 1, wherein the motion detection device produces motion detection that is omni omni-directional.
21. The system of claim 20, wherein the motion detection rejects signals that are not relevant by first determining a range of a target of interest and then ignoring signals that are further than specified bounds from the target of interest.
22. The system of claim 1, wherein at least one of sensor data, audio data and motion detection data is used to reject false position signals relative to the person's sleep and/or sleep related parameters.

\* \* \* \* \*

专利名称(译)	具有可选无线通信的监控设备		
公开(公告)号	<a href="#">US9756403</a>	公开(公告)日	2017-09-05
申请号	US15/242540	申请日	2016-08-21
[标]申请(专利权)人(译)	你好		
申请(专利权)人(译)	HELLO INC.		
当前申请(专利权)人(译)	HELLO INC.		
[标]发明人	PROUD JAMES		
发明人	PROUD, JAMES		
IPC分类号	H04Q9/00 H02J7/02 A61B5/0205 H04L29/08 H04W4/00 H04W4/20 A61B90/90 A61B90/98 G01D4/00 G08C17/02 H02J50/80 H02J7/00 A61B5/11 A61B5/00		
CPC分类号	H04Q9/00 A61B5/0022 A61B5/0024 A61B5/02055 A61B90/90 A61B90/98 G01D4/002 G08C17/02 H02J7/025 H02J50/80 H04L67/02 H04L67/125 H04W4/005 H04W4/008 H04W4/206 A61B5/1112 A61B5/1118 A61B5/443 A61B5/6831 A61B5/6898 A61B5/743 A61B2560/0214 A61B2562/0233 A61B2562/08 H02J2007/0096 G06F19/00 G16H40/67 H02J7/00034 H02J50/10 H04W4/21 H04W4/70 H04W4/80		
代理人(译)	DAVIS , PAUL		
优先权	13/923909 2016-08-02 US 13/923637 2014-08-19 US 13/923614 2014-09-30 US 13/923809 2016-08-23 US 13/923750 2016-09-06 US 13/923560 2014-08-12 US 61/772265 2013-03-04 US 61/823502 2013-05-15 US 61/812083 2013-04-15 US		
其他公开文献	US20160360300A1		
外部链接	<a href="#">Espacenet</a> <a href="#">USPTO</a>		

摘要(译)

一个或多个传感器耦合到具有唯一用户ID的监控设备。一个或多个传感器获取从用户的活动，行为和习惯信息中的至少一个中选择的用户信息。包括ID存储器的ID电路，从ID存储器读取和发送唯一ID的通信系统，电源和通过电路路由信号的通路系统位于监视设备处。耦合到一个或多个无线接口的多协议无线控制器位于监视设备处，并且表征可用网络以确定当前网络信息。无线连接助手位于监视设备处，并基于当前网络信息以及用户偏好，应用要求和系统信息中的至少一个来选择可用网络之一。遥测系统与监视设备通信。

