



(19) **United States**

(12) **Patent Application Publication**  
**Ni et al.**

(10) **Pub. No.: US 2018/0296829 A1**  
(43) **Pub. Date: Oct. 18, 2018**

(54) **TRANSVENOUS METHOD OF TREATING SLEEP APNEA**

**Publication Classification**

- (71) Applicant: **INSPIRE MEDICAL SYSTEMS, INC.**, Maple Grove, MN (US)
- (72) Inventors: **Quan Ni**, Maple Grove, MN (US); **Mark A. Christopherson**, Maple Grove, MN (US); **Timothy P. Herbert**, Maple Grove, MN (US); **John Rondoni**, Maple Grove, MN (US)
- (73) Assignee: **INSPIRE MEDICAL SYSTEMS, INC.**, Maple Grove, MN (US)

- (51) **Int. Cl.**  
*A61N 1/36* (2006.01)  
*A61N 1/372* (2006.01)  
*A61B 5/00* (2006.01)  
*A61F 2/848* (2013.01)  
*A61F 2/86* (2013.01)
- (52) **U.S. Cl.**  
 CPC ..... *A61N 1/3601* (2013.01); *A61N 1/37205* (2013.01); *A61F 2/86* (2013.01); *A61F 2/848* (2013.01); *A61B 5/4818* (2013.01)

- (21) Appl. No.: **15/894,484**
- (22) Filed: **Feb. 12, 2018**

**Related U.S. Application Data**

- (62) Division of application No. 13/121,862, filed on Apr. 29, 2011, now Pat. No. 9,889,299, filed as application No. PCT/US2009/059060 on Sep. 30, 2009.
- (60) Provisional application No. 61/101,952, filed on Oct. 1, 2008.

(57) **ABSTRACT**

A system and method for treating sleep apnea includes inserting an implantable pulse generator subcutaneously within a body of a patient and connecting a lead to the pulse generator. The lead is inserted within the vasculature and advanced transvenously through the vasculature until a stimulation portion of the lead becomes positioned in close proximity to the hypoglossal nerve. A nerve-stimulation signal is applied to the hypoglossal nerve via the stimulation portion of the lead.

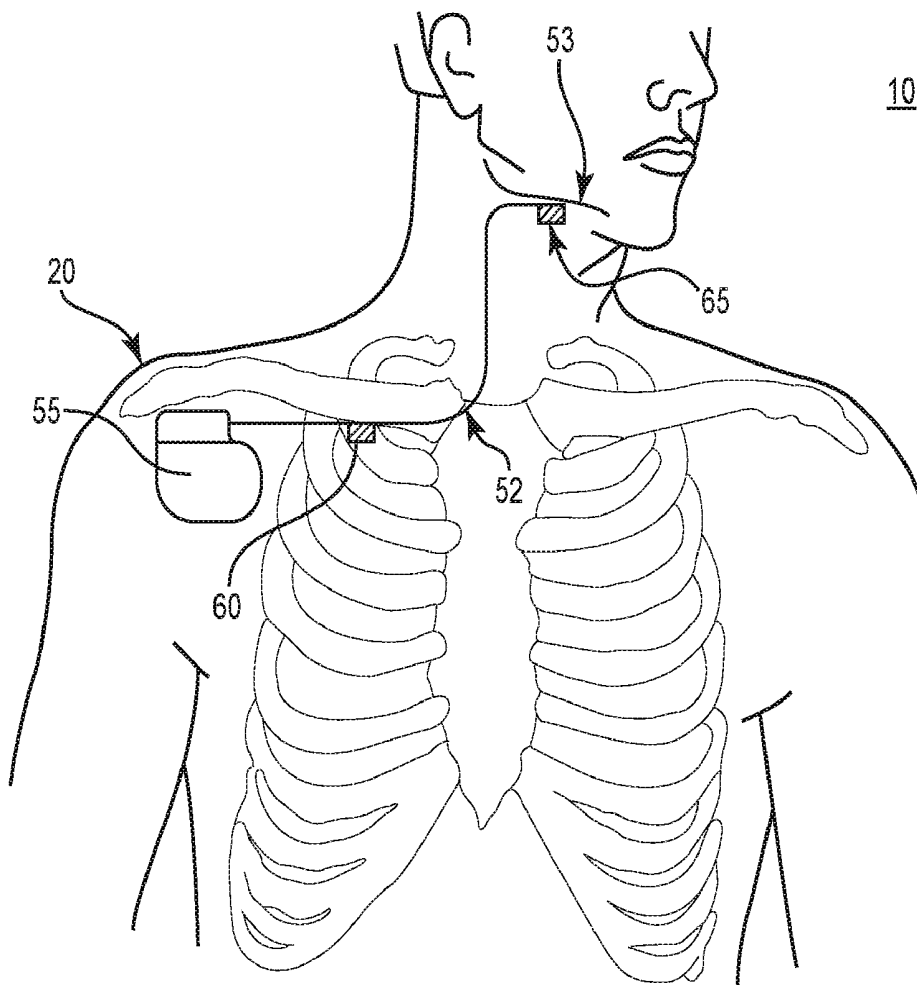

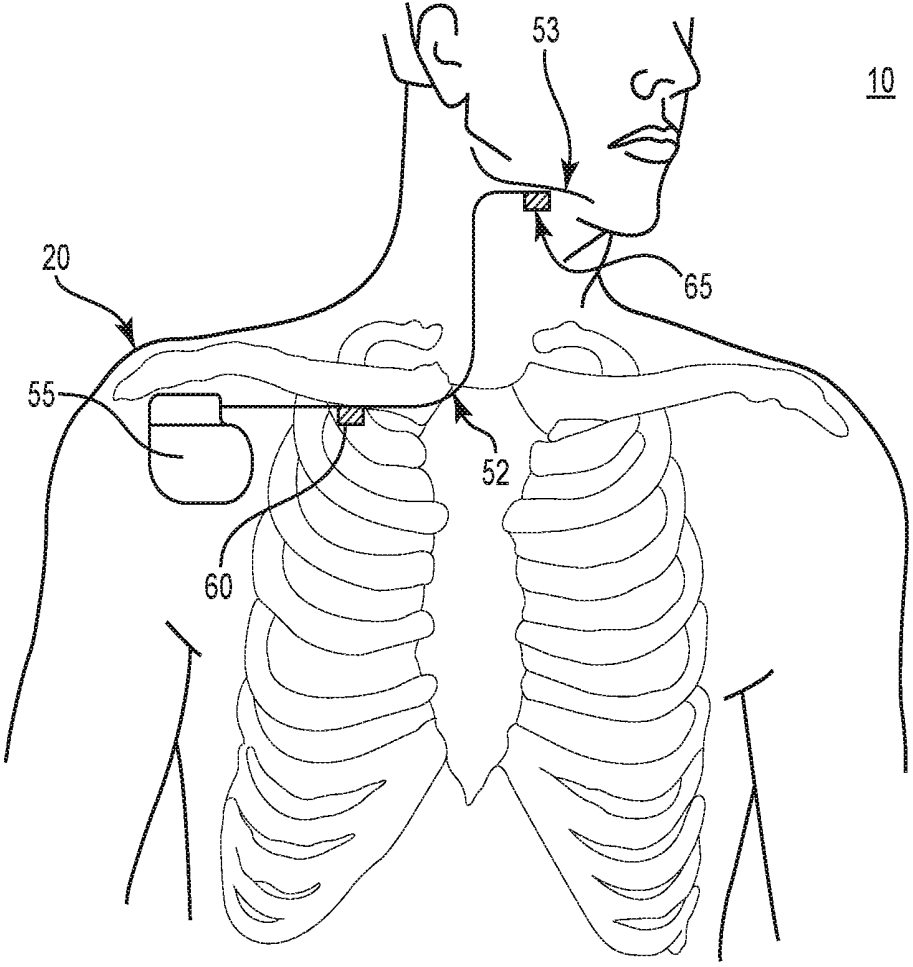

Fig. 1

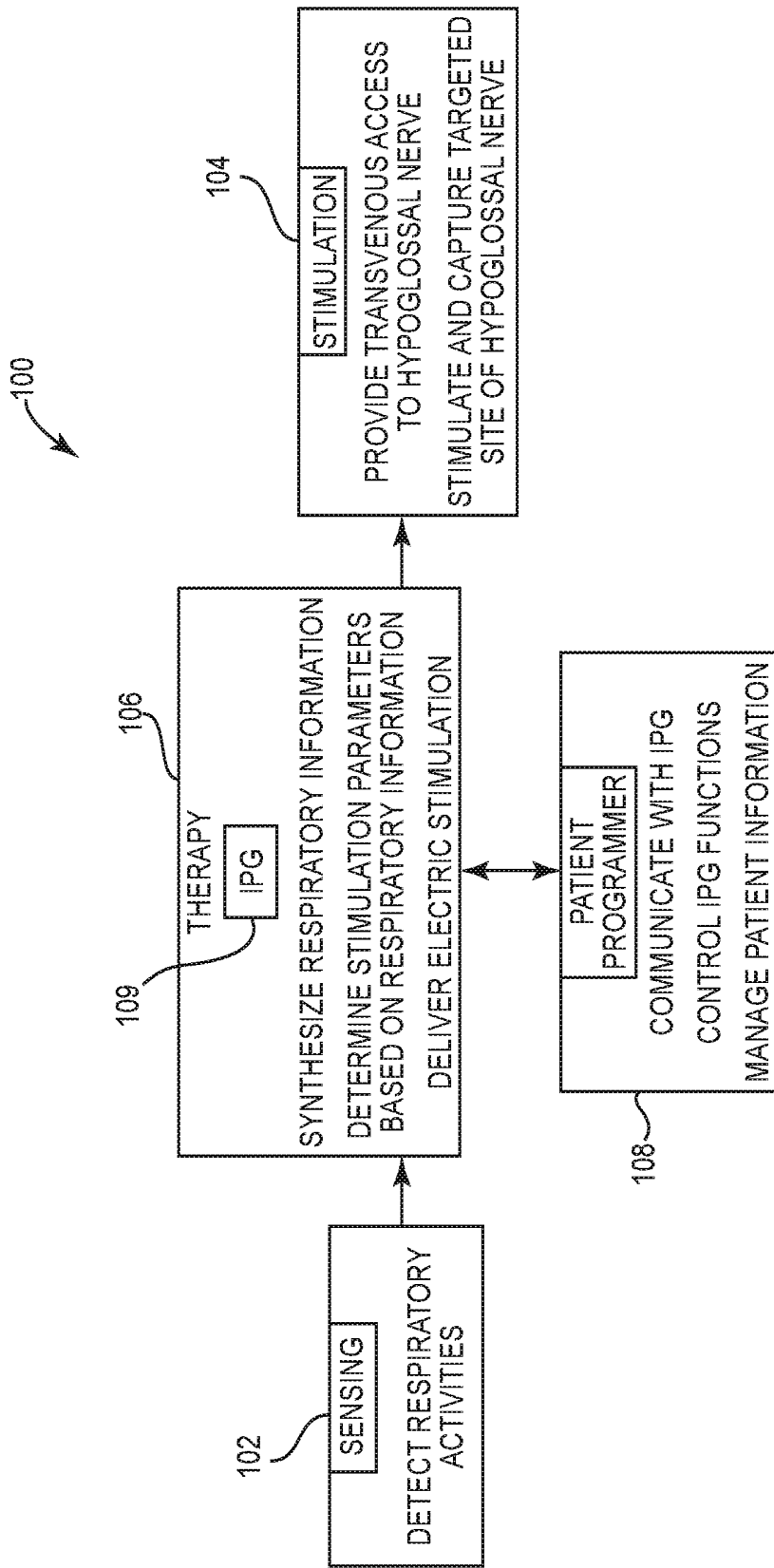

Fig. 2A

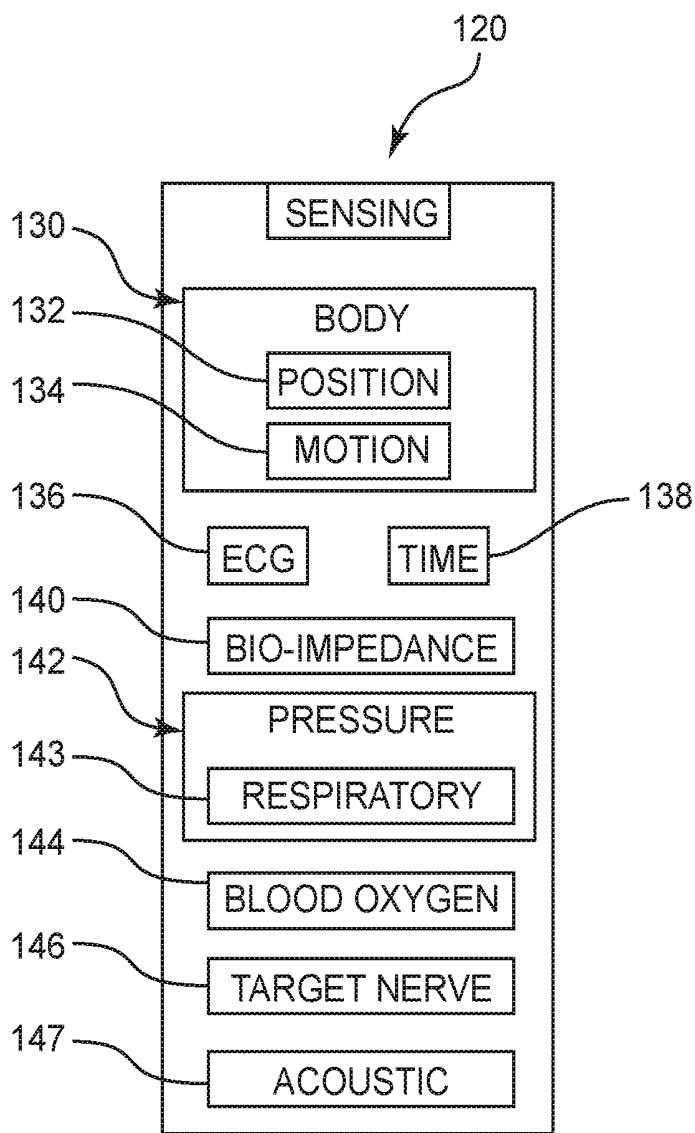

Fig. 2B

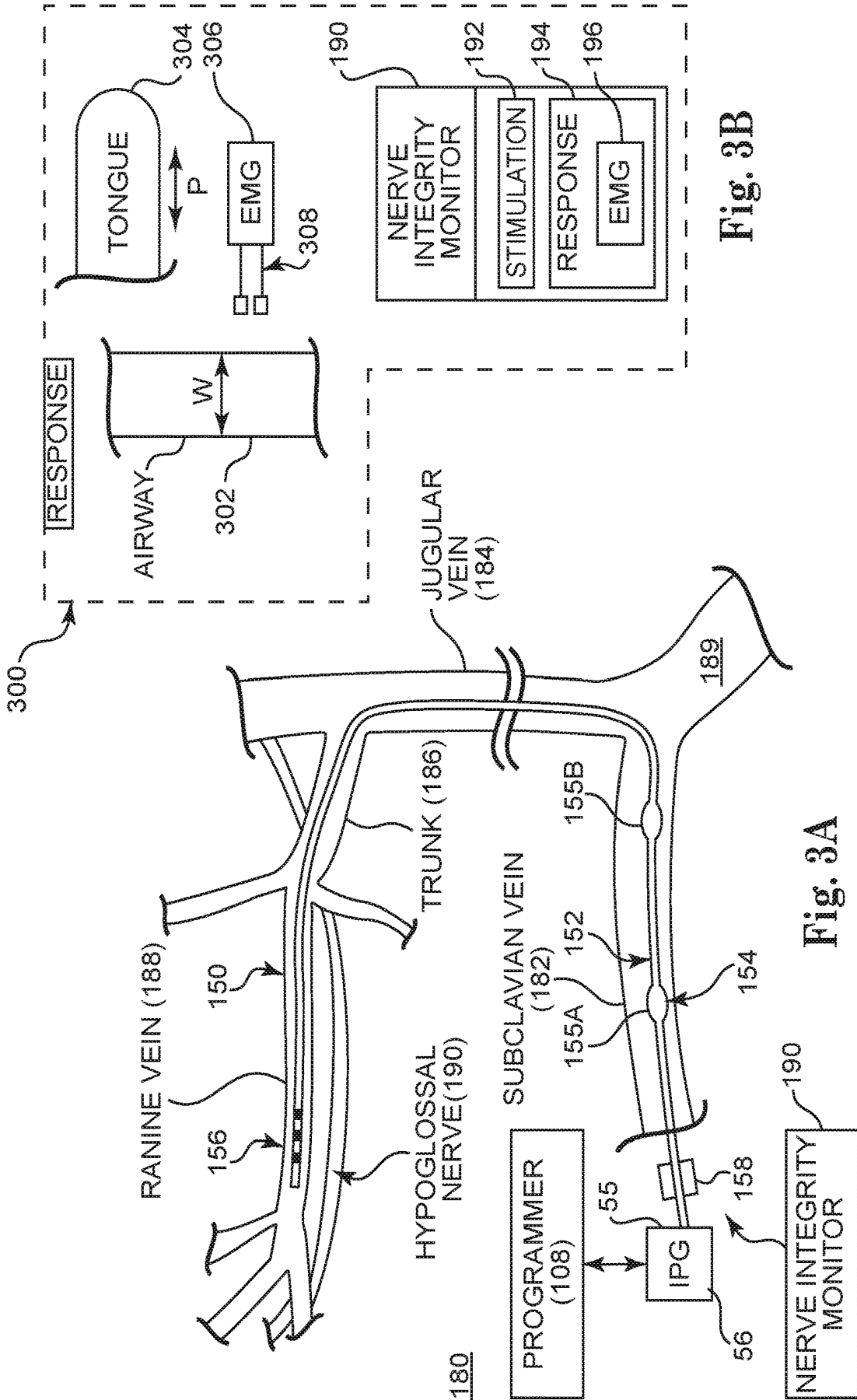

Fig. 3B

Fig. 3A

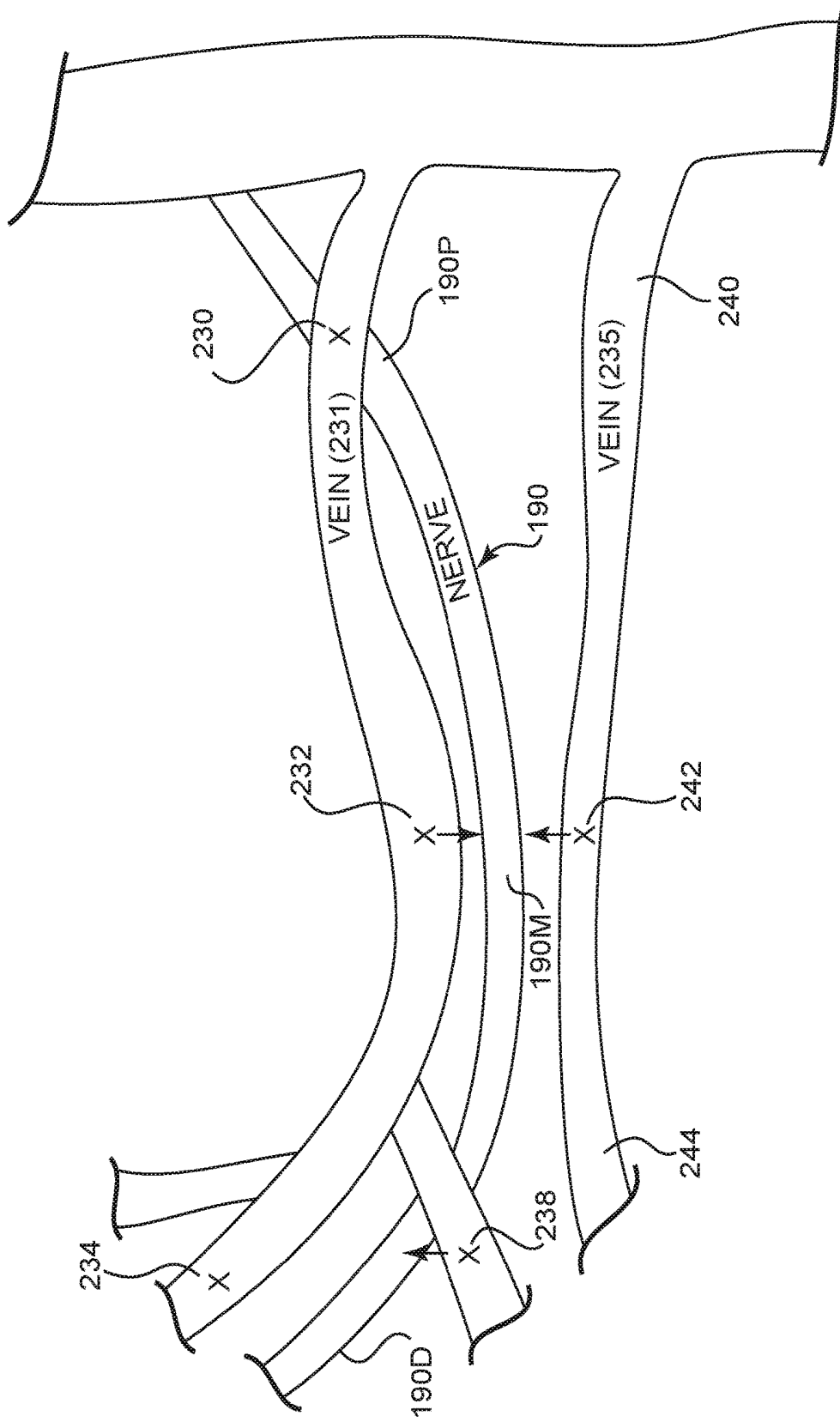

Fig. 4A

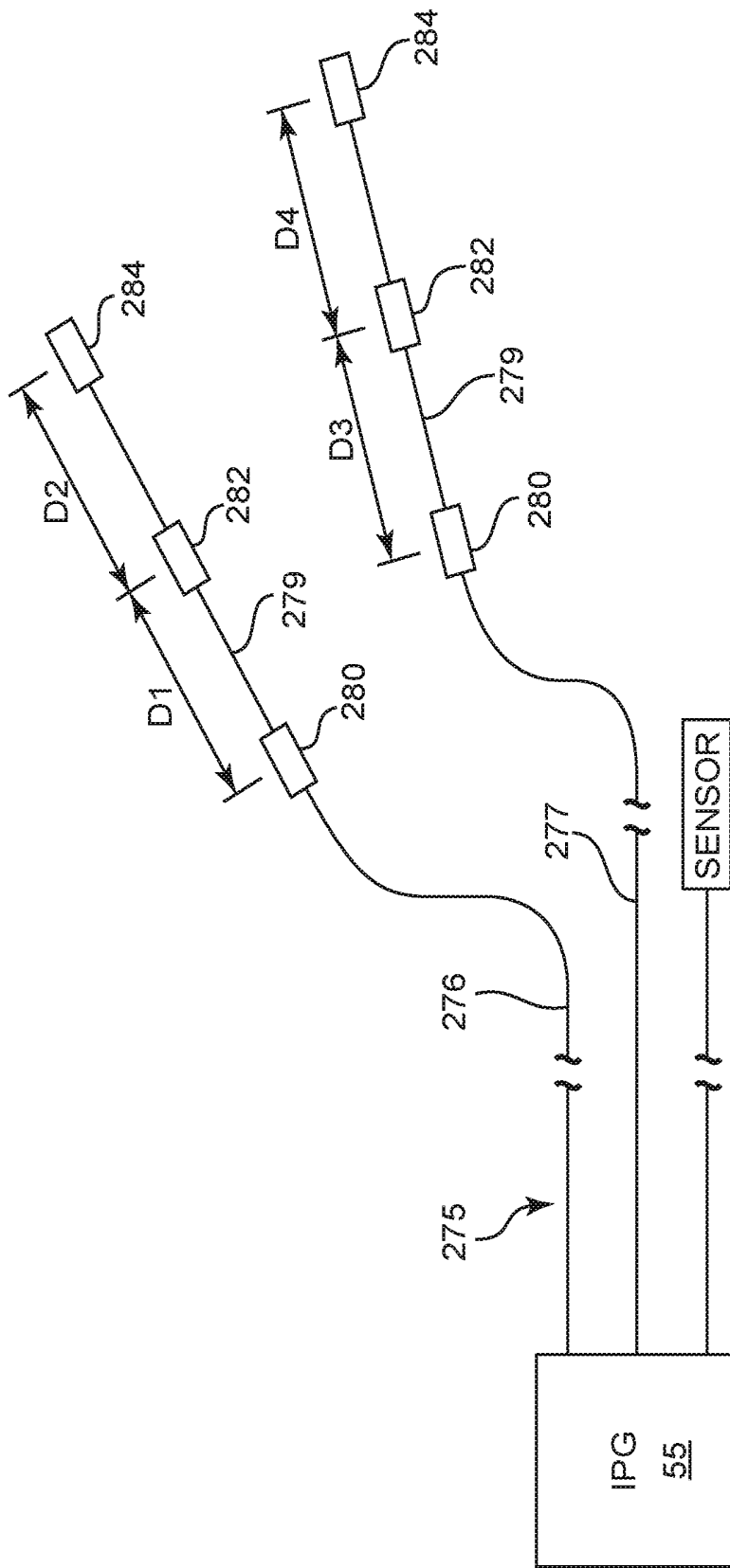

Fig. 4B

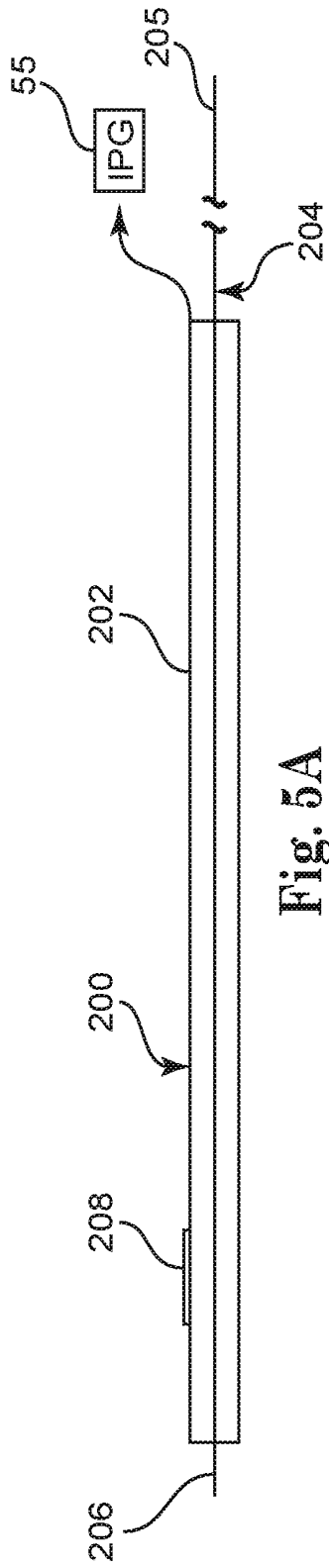

Fig. 5A

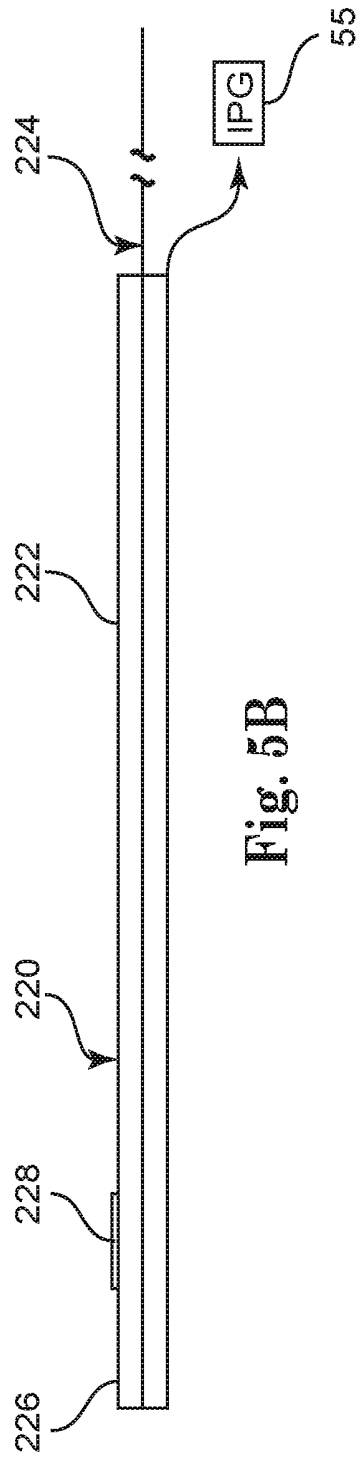

Fig. 5B

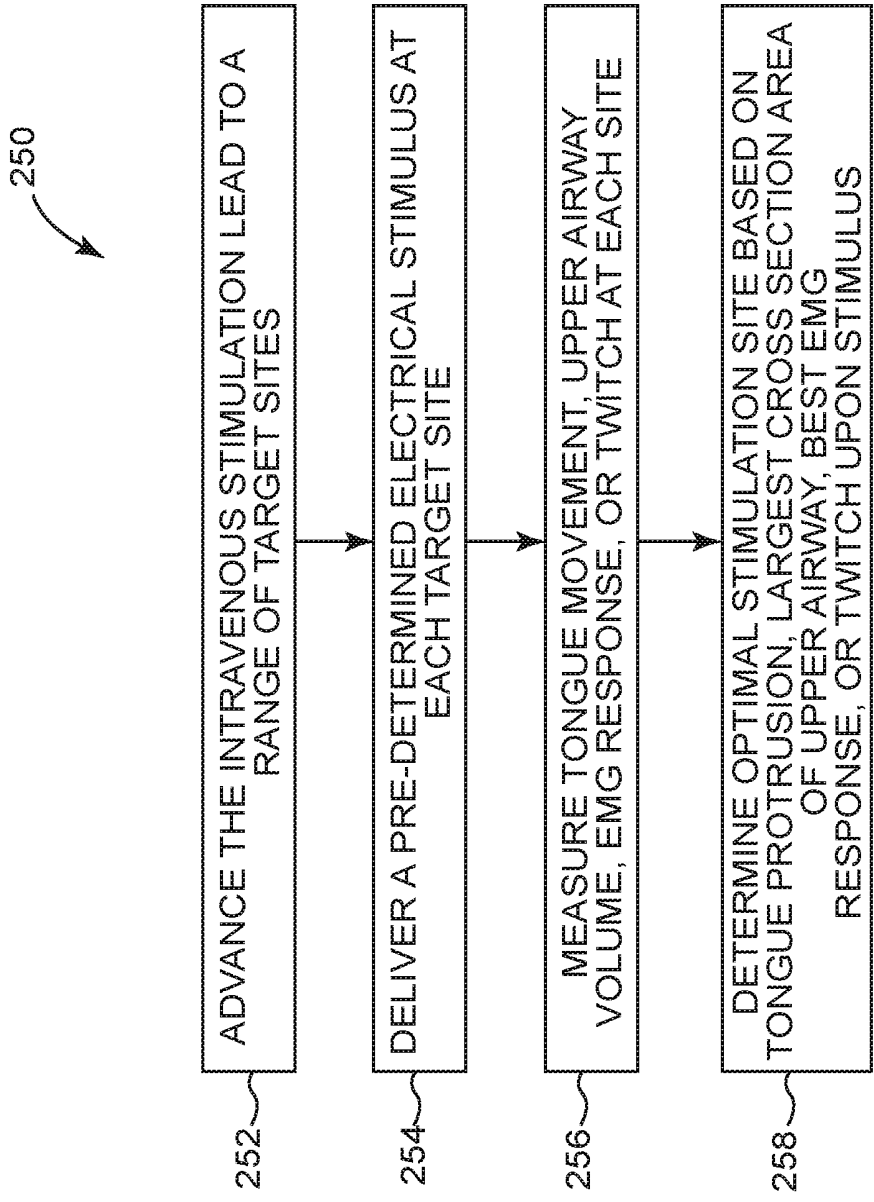
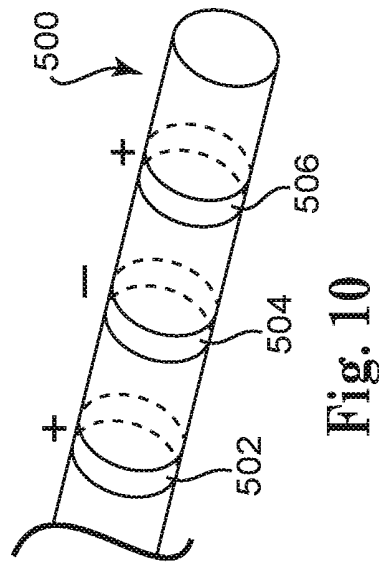
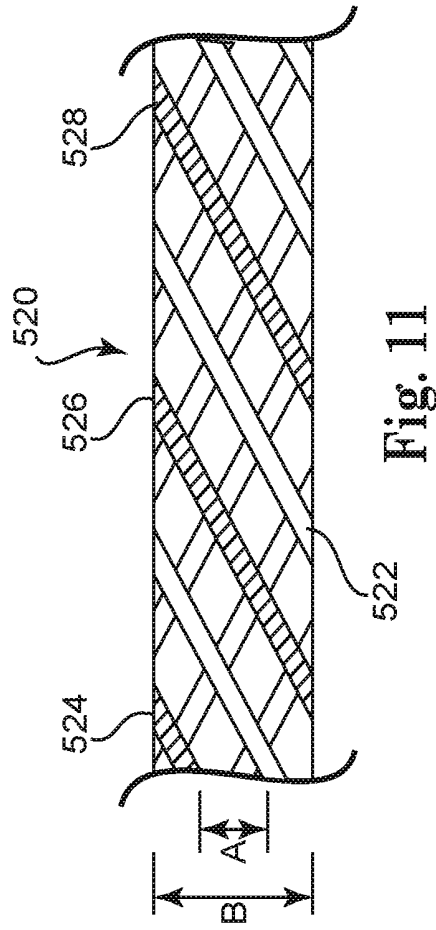
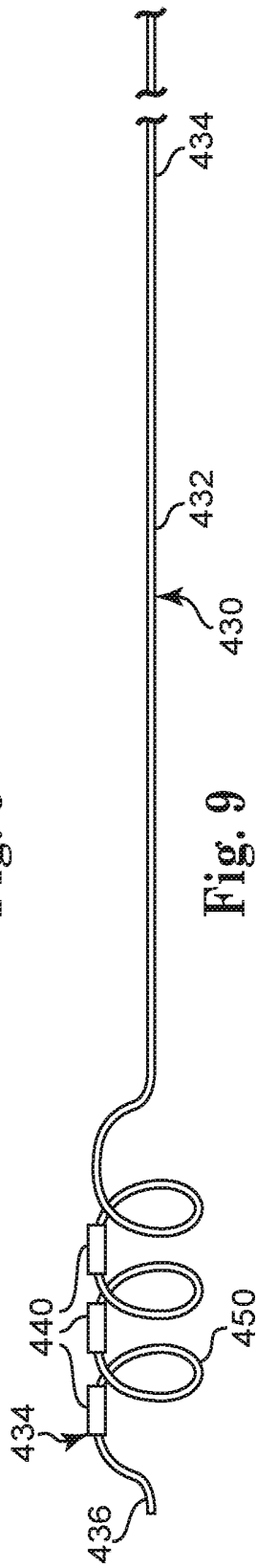
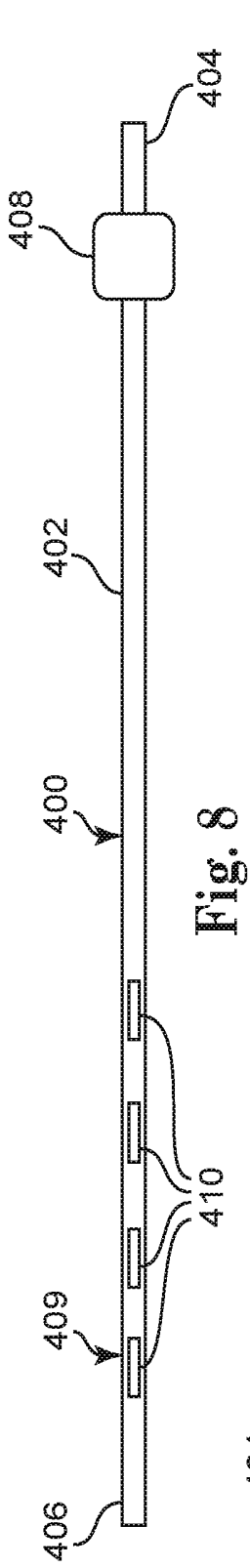

Fig. 6





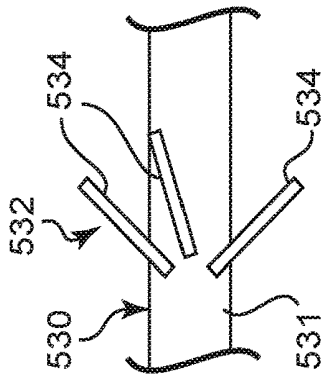

Fig. 12A

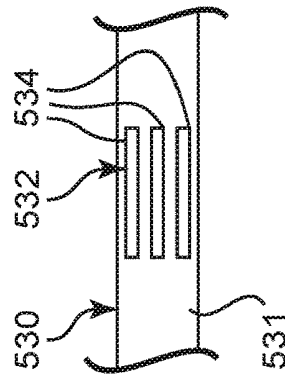

Fig. 12B

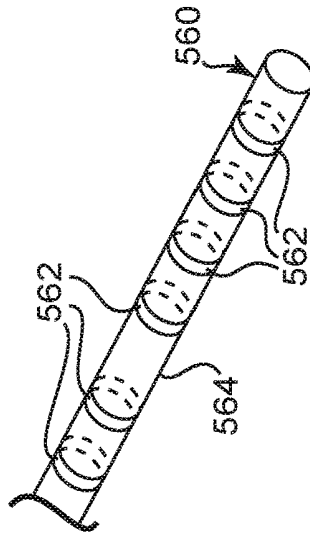

Fig. 14

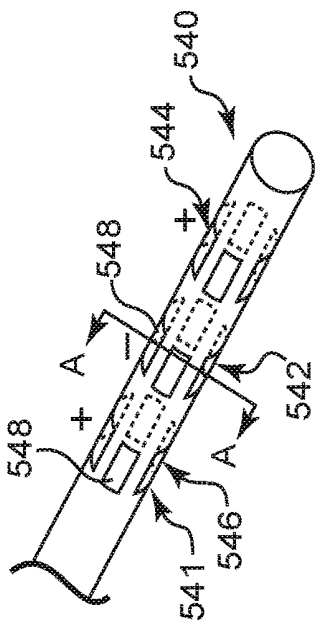
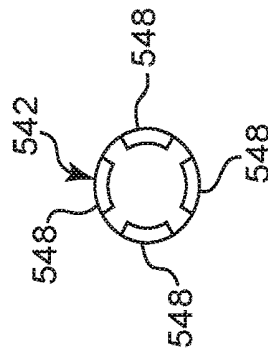

Fig. 13A



VIEW A-A

Fig. 13B

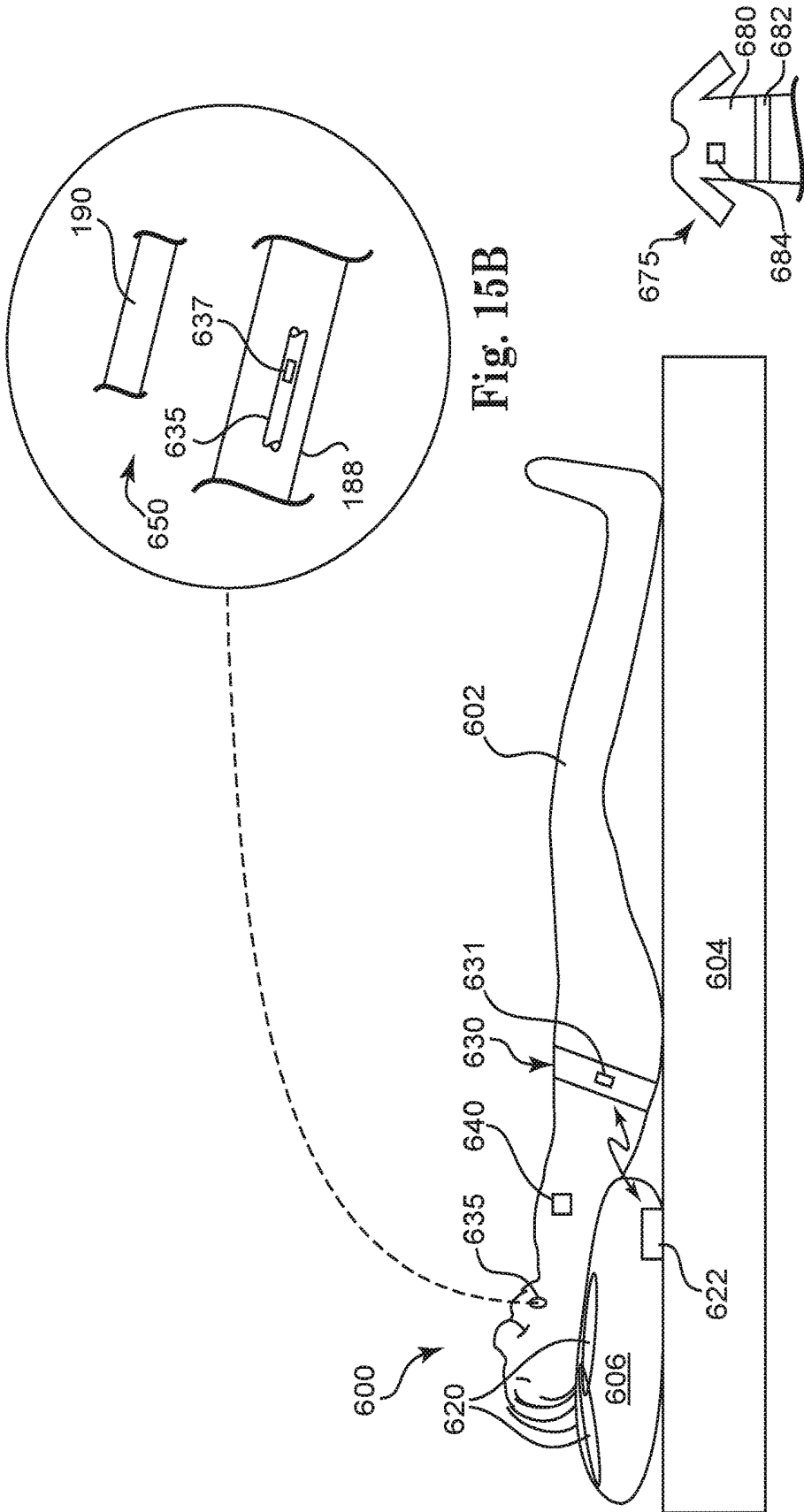

Fig. 15B

Fig. 15A

Fig. 15C

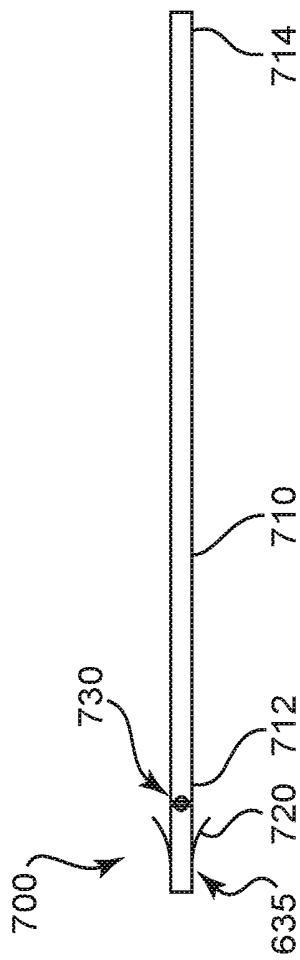

Fig. 16

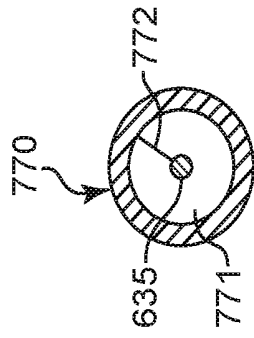

Fig. 17B

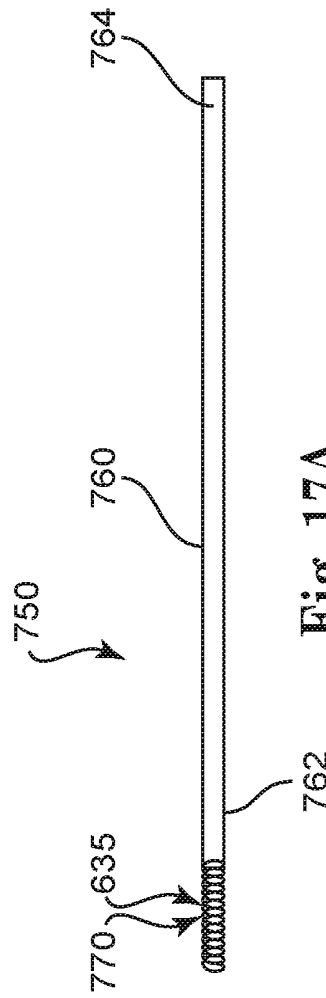

Fig. 17A

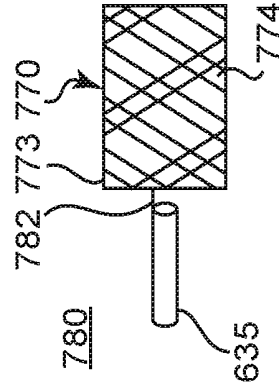

Fig. 17C

## TRANSVENOUS METHOD OF TREATING SLEEP APNEA

### CROSS-REFERENCE TO RELATED APPLICATIONS

[0001] This Patent Application is a Divisional of U.S. National Stage Application Ser. No. 13/121,862, which entered National Phase on Apr. 29, 2011 and which claims benefit of PCT/US2009/59060, filed Sep. 30, 2009 and U.S. Provisional Application No. 61/101,952, filed Oct. 1, 2008, all of which are incorporated herein by reference.

### BACKGROUND

[0002] The present disclosure relates generally to an implantable stimulation system for stimulating and monitoring soft tissue in a patient, and more particularly, the present disclosure relates to a method of using a transvenous delivery of a stimulation lead to treat sleep apnea.

[0003] Sleep apnea generally refers to the cessation of breathing during sleep. One type of sleep apnea, referred to as obstructive sleep apnea (OSA), is characterized by repetitive pauses in breathing during sleep due to the obstruction and/or collapse of the upper airway, and is usually accompanied by a reduction in blood oxygenation saturation.

[0004] One treatment for obstructive sleep apnea has included the delivery of electrical stimulation to the hypoglossal nerve, located in the neck region under the chin. Such stimulation therapy activates the upper airway muscles to maintain upper airway patency. In treatment of sleep apnea, increased respiratory effort resulting from the difficulty in breathing through an obstructed airway is avoided by synchronized stimulation of an upper airway muscle or muscle group that holds the airway open during the inspiratory phase of breathing. For example, the genioglossus muscle is stimulated during treatment of sleep apnea by a cuff electrode placed around the hypoglossal nerve.

### BRIEF DESCRIPTION OF THE DRAWINGS

[0005] Aspects and features of the present disclosure will be appreciated as the same becomes better understood by reference to the following detailed description of the embodiments of the present disclosure when considered in connection with the accompanying drawings, wherein:

[0006] FIG. 1 is a schematic illustration of an implantable stimulation system, according to an embodiment of the present disclosure;

[0007] FIG. 2A is a schematic illustration of a block diagram of an implantable stimulation system, according to an embodiment of the present disclosure;

[0008] FIG. 2B is a schematic illustration of a block diagram of a sensing monitor, according to an embodiment of the present disclosure;

[0009] FIG. 3A is a schematic illustration of a transvenous placement of a stimulation lead and sensor for treating sleep apnea, according to an embodiment of the present disclosure;

[0010] FIG. 3B is a schematic illustration of an array of response evaluation tools and a nerve monitoring system, according to an embodiment of the present disclosure;

[0011] FIG. 4A is a schematic illustration of a method of stimulating a nerve via multiple venous pathways and/or via multiple stimulation sites, according to an embodiment of the present disclosure;

[0012] FIG. 4B is a schematic illustration of a stimulation lead system including multiple independent stimulation leads, according to an embodiment of the present disclosure;

[0013] FIG. 5A is a side plan view of an over-the-wire delivery system for a stimulation lead, according to an embodiment of the present disclosure;

[0014] FIG. 5B is a side plan view of an stylet-driven delivery mechanism for a stimulation lead, according to an embodiment of the present disclosure;

[0015] FIG. 6 is a schematic illustration of a method of selecting a stimulation site, according to an embodiment of the present disclosure;

[0016] FIG. 7 is a schematic illustration of a transvenous placement of a stimulation lead and sensor for treating sleep apnea, according to an embodiment of the present disclosure;

[0017] FIG. 8 is a side plan view of a stimulation lead, according to an embodiment of the present disclosure;

[0018] FIG. 9 is a side plan view of a stimulation lead including a coiled configuration at a distal portion, according to an embodiment of the present disclosure;

[0019] FIG. 10 is a perspective view of a distal portion of a stimulation lead including an array of ring electrodes, according to an embodiment of the present disclosure;

[0020] FIG. 11 is a side plan view of a distal portion of a stimulation lead including a combined stent-electrode configuration, according to an embodiment of the present disclosure;

[0021] FIG. 12A is a side plan view of a distal portion of a stimulation lead including an array of selectively deployable tines shown in a deployed configuration, according to an embodiment of the present disclosure;

[0022] FIG. 12B is a side plan view of the lead of FIG. 12A with the tines shown in a storage position, according to an embodiment of the present disclosure;

[0023] FIG. 13A is a perspective view of a distal portion of a stimulation lead including a programmable array of electrodes mounted circumferentially around the lead, according to an embodiment of the present disclosure;

[0024] FIG. 13B is a sectional view as taken along lines A-A of FIG. 13A of the array of electrodes, according to an embodiment of the present disclosure;

[0025] FIG. 14 is a perspective view of a distal portion of a stimulation lead including an array of programmable ring electrodes, according to an embodiment of the present disclosure;

[0026] FIG. 15A is a side plan view schematically illustrating a nerve stimulation system, according to an embodiment of the present disclosure;

[0027] FIG. 15B is a schematic illustration of a transvenous placement of a microstimulator of the system of FIG. 15A, according to an embodiment of the present disclosure;

[0028] FIG. 15C is a schematic illustration of a garment configured to provide respiratory sensing for the system of FIGS. 15A-15B, according to an embodiment of the present disclosure;

[0029] FIG. 16 is a side plan view schematically illustrating an anchoring system of a transvenously delivered microstimulator, according to an embodiment of the present disclosure;

[0030] FIG. 17A is a side plan view schematically illustrating a stent-based anchoring system of a transvenously delivered microstimulator, according to an embodiment of the present disclosure;

**[0031]** FIG. 17B is a sectional view schematically illustrating a microstimulator and a stent of the anchoring system of FIG. 17A, according to an embodiment of the present disclosure; and

**[0032]** FIG. 17C is a side plan view schematically illustrating a microstimulator and a stent of the anchoring system of FIG. 17A, according to an embodiment of the present disclosure.

#### DESCRIPTION OF EMBODIMENTS

**[0033]** The following detailed description is merely exemplary in nature and is not intended to limit the present disclosure or the application and uses of the present disclosure. Furthermore, there is no intention to be bound by any expressed or implied theory presented in the preceding technical field, background, or the following detailed description.

**[0034]** Embodiments of the present disclosure provide an implantable medical device for treating obstructive sleep apnea wherein stimulation is provided to the hypoglossal nerve (or another target nerve) through a transvenous lead system. The stimulation may be provided synchronous with respiration detected by a sensing lead system. In some embodiments, a single transvenous lead includes both a sensing lead and the stimulation lead, such that the sensing lead is integral with or connected to the stimulation lead. In other embodiments, the sensing lead forms a transvenous lead separate from a transvenous stimulation lead. In still other embodiments, the sensing lead comprises a sensing lead external to the venous system altogether (such as being mounted externally on a patient or subcutaneously implanted) while the stimulation lead comprises a transvenous lead.

**[0035]** FIG. 1 is a schematic diagram of an implantable stimulation system that includes a transvenously placed stimulation electrode, according to an embodiment of the present disclosure. As illustrated in FIG. 1, an example of an implantable stimulation system 10 according to one embodiment of the present disclosure includes an implantable pulse generator (IPG) 55, capable of being surgically positioned within a pectoral region of a patient 20, and a stimulation lead 52 electrically coupled with the IPG 55 via a connector (not shown) positioned within a connection port of the IPG 55. The lead 52 includes a stimulation electrode portion 65 and extends from the IPG 55 so that the stimulation electrode portion 65 is positioned within a portion of the vasculature adjacent a desired nerve, such as the hypoglossal nerve 53 of the patient 10, to enable stimulation of the nerve 53, as described below in detail. An exemplary implantable stimulation system in which lead 52 may be utilized, for example, is described in U.S. Pat. No. 6,572,543 to Christopherson et al., and which is incorporated herein by reference in its entirety. In one embodiment, the lead 52 further includes an sensor portion 60 (electrically coupled to the IPG 55 and extending from the IPG 55) positioned in the patient 10 for sensing respiratory effort.

**[0036]** In some embodiments, in addition to the IPG 55 being configured to treat obstructive sleep apnea, the IPG 55 is additionally configured as a cardiac therapy device, such as a bradycardia pacemaker, implantable cardiac defibrillator, or cardiac resynchronization therapy device. In one aspect, one or more leads extend from the IPG 55 to access the heart via a transvenous approach in order to apply a cardiac therapy. In one embodiment, one or more of these

cardiac therapy configurations of the IPG 55 also have sensors (pressure, impedance) on the cardiac leads which may also provide a respiratory signal for use in delivering an obstructive sleep apnea therapy. Exemplary embodiments of an implantable stimulation system for applying a cardiac therapy via transvenous delivery of a lead is described in Hill et al. U.S. Pat. No. 6,006,134 and Cho et al. U.S. Pat. No. 6,641,542, which are both incorporated by reference herein in their entirety.

**[0037]** In one embodiment in which the IPG 55 is configured to treat both cardiac therapy and sleep apnea, a first lead (or set of leads) extends from the IPG 55 for sensing cardiac activity and detecting cardiac events while a second lead (or set of leads) extends from the IPG 55 to sense respiratory activity and to detect respiratory events. However, in another embodiment, only one set of leads is used to sense both respiratory activity and cardiac activity. Accordingly, in this latter embodiment, in one configuration, a respiratory signal obtained via a cardiac sensing lead is also used to trigger application of a stimulation signal when applying an obstructive sleep apnea therapy, and also optionally is used to monitor and detect apneas.

**[0038]** In some embodiments, instead of using a single IPG to apply both cardiac therapies and sleep apnea therapies, a second implantable pulse generator (IPG 55) is implanted (in addition to the first IPG) so that one IPG 55 applies a cardiac therapy while the other IPG 55 applies an obstructive sleep apnea therapy.

**[0039]** FIG. 2A is a block diagram schematically illustrating an implantable stimulation system 100, according to one embodiment of the present disclosure. In one embodiment, system 100 comprises at least substantially the same features and attributes as system 10 of FIG. 1. As illustrated in FIG. 2A, system 100 includes a sensing module 102, a stimulation module 104, a therapy module 106, and a patient management module 108. In one embodiment, the IPG 109 of therapy module 106 comprises at least substantially the same features and attributes as IPG 55 of FIG. 1.

**[0040]** Via an array of parameters, the sensing module 102 receives and tracks signals from various physiologic sensors (such as a pressure sensor, blood oxygenation sensor, acoustic sensor, electrocardiogram (ECG) sensor, or impedance sensor) in order to determine a respiratory state of a patient, whether or not the patient is asleep or awake, and other respiratory-associated indicators, etc. Such respiratory detection may be received from either a single sensor or any multiple of sensors, or combination of various physiologic sensors which may provide a more reliable and accurate signal.

**[0041]** For example, in one embodiment, the sensing module 102 comprises a sensing monitor 120, as illustrated in FIG. 2B. The sensing monitor 120 includes a body parameter 130, which includes at least one of a position-sensing component 132 or a motion-sensing component 134. In one embodiment, the motion-sensing component 134 tracks sensing of "seismic" activity (via an accelerometer or a piezoelectric transducer) that is indicative of walking, body motion, talking, etc. In another embodiment, the position-sensing component 132 tracks sensing of a body position or posture via an accelerometer or other transducer. In some embodiments, body parameter 130 utilizes signals from both the position-sensing component 132 and the motion-sensing component 134.

[0042] In some embodiments, sensing monitor 120 additionally comprises one or more of the following parameters: an ECG parameter 136; a time parameter 138; a bio-impedance parameter 140; a pressure parameter 142; and a blood oxygen parameter 144. In one aspect, the pressure parameter 142 includes a respiratory pressure component 143. In one aspect, the time parameter 142 tracks time generally (e.g. time intervals, elapsed time, etc.) while in other aspects, the time parameter 142 tracks the time of day in addition to or instead of the general time parameters. In another aspect, the time parameter 142 can be used to activate or deactivate a therapy regimen according to a time of day.

[0043] It is also understood that system 100 (FIG. 2A) would include, or be connected to, the analogous physiologic sensor (e.g., LED-type tissue perfusion oxygen saturation) implanted within or attached to the body of the patient to provide data to each one of their respective parameters (e.g., blood oxygenation parameter 144) of the sensing monitor 120. In some embodiments, sensing monitor 120 also includes a target nerve parameter 146 which represents physiologic data regarding the activity of a nerve to be stimulated, such as the hypoglossal nerve, including specification of the trunk and/or one or more branches of the hypoglossal nerve.

[0044] In other embodiments, the target nerve comprises another nerve (other than the hypoglossal nerve) that facilitates a therapy regimen to treat obstructive sleep apnea. In yet other embodiments, sensing monitor 120 also includes an acoustic sensing parameter 147 which represents physiologic data from respiratory airflow or cardiac activity that is sensed acoustically and that is indicative of respiratory effort.

[0045] In further reference to FIG. 2A, therapy manager 106 of system 100 is configured to automatically control initiation, termination, and/or adjustment of a sleep apnea therapy, in accordance with the principles of the present disclosure. Therapy manager 106 also tracks and applies various treatment parameters, such as an amplitude, pulse width, electrode polarity, duration, and/or frequency of a neuro-stimulation signal, in accordance with a treatment protocol programmed into the therapy manager 106.

[0046] In one embodiment, therapy manager 106 comprises one or more processing units and associated memories configured to generate control signals directing the operation of system 100, including at least sensing module 102, therapy manager 106, stimulation module 104, and patient management module 108. In particular, in response to or based upon commands received via an input and/or instructions contained in the memory associated with the controller in response to physiologic data gathered via the sensing module 102, therapy manager 106 generates control signals directing operation of stimulation module 104 to selectively control stimulation of a target nerve, such as the hypoglossal nerve, to restore airway patency and thereby reduce or eliminate apneic events.

[0047] With this in mind, therapy manager 106 acts to synthesize respiratory information, to determine suitable stimulation parameters based on that respiratory information, and to direct electrical stimulation to the target nerve. While any number of physiologic parameters can be used with varying success to detect an apnea, in one embodiment of the present disclosure, the sensing module 102 detects apneas via a thoracic bio-impedance parameter. In particu-

lar, a measurement of thoracic impedance is used to track the relative amplitude of the respiratory waveform. Physiologically speaking, the bio-impedance of the lungs varies as the lungs fill and empty with air. Accordingly, thoracic impedance increases during inspiration and decreases during expiration. In another aspect, a varying respiratory drive will also cause the amplitude of the bio-impedance to vary, with a larger respiratory drive increasing the signal amplitude of the bio-impedance. In one embodiment, the vector providing the bio-impedance measurement is predominantly lung-volume related, and not due to diaphragm displacement or cardiac displacement during respiration.

[0048] Upon obtaining the bio-impedance signal, the bio-impedance signal is further processed to identify an average peak amplitude over time. An apnea is detected by further identifying cyclic amplitude variations that occur for a duration substantially similar to the already known duration of a typical apneic event.

[0049] For purposes of this application, the term “processing unit” shall mean a presently developed or future developed processing unit that executes sequences of instructions contained in a memory. Execution of the sequences of instructions causes the processing unit to perform steps such as generating control signals. The instructions may be loaded in a random access memory (RAM) for execution by the processing unit from a read only memory (ROM), a mass storage device, or some other persistent storage, as represented by a memory associated with the controller. In other embodiments, hard wired circuitry may be used in place of or in combination with software instructions to implement the functions described. For example, the controller may be embodied as part of one or more application-specific integrated circuits (ASICs). Unless otherwise specifically noted, the controller is not limited to any specific combination of hardware circuitry and software, nor limited to any particular source for the instructions executed by the processing unit.

[0050] In general terms, the stimulation module 104 of system 100 is configured to generate and apply a neuro-stimulation signal via electrode(s) (such as stimulation electrode(s) 65) according to a treatment regimen programmed by a physician and/or in cooperation with therapy manager 106.

[0051] In general terms, the patient management module 108 is configured to facilitate communication to and from the IPG 109 in a manner familiar to those skilled in the art. Accordingly, the patient management module 108 is configured to report activities of the IPG 109 (including sensed physiologic data, stimulation history, number of apneas detected, etc.) and is configured to receive initial or further programming of the IPG 109 from an external source, such as a patient programmer, clinician programmer, etc.

[0052] FIG. 3A schematically illustrates a lead 150 in one exemplary embodiment of the implantable stimulation system 10 of FIG. 1. As shown in FIG. 3A, lead 150 is configured to be delivered transvenously and to be positioned within the vasculature. Lead 150 is configured to place a stimulation electrode portion 156 within the ranine vein 188 adjacent the hypoglossal nerve 190 (or another vein adjacent the hypoglossal nerve or another target nerve). In one aspect, the ranine vein is the vena comitans of the hypoglossal nerve, which begins at its distal end at a point below the front of the tongue, travels along the distal portion of the hypoglossal nerve, and then may join the lingual vein,

and eventually opens into the internal jugular vein. In another aspect, other veins, such as another branch of the lingual vein may also be a candidate for the simulation electrode placement instead of the ranine vein or in addition to the ranine vein.

[0053] Accordingly, lead 150 is employable in a method of transvenously delivering a stimulation electrode to stimulate a target nerve. In this method, as illustrated in FIG. 3A, lead 150 is introduced into and through the subclavian vein 182 and then is advanced through the jugular vein 184, through vein trunk 186, and into the ranine vein 190 (otherwise known as the vein comitans of the hypoglossal nerve) until stimulation electrode portion 156 is within a desired position of the ranine vein 180 (or another vein adjacent a target nerve).

[0054] In some embodiments, the neuro-stimulation signal is applied at a single stimulation site along the hypoglossal nerve or another target nerve, as illustrated in FIG. 3A. However, in other embodiments, the neuro-stimulation signal of a sleep apnea therapy is applied from one or more of multiple locations 230, 232, 234, 240, 242, 244 (represented by the symbol x) within one or more veins to target multiple stimulation sites 190P, 190M, 190D along a target nerve 190, as schematically illustrated in FIG. 4A. The electric field applied at each site is represented schematically by the directional arrow extending from the symbol x toward the stimulation site 190M, 190P, 190D on nerve 190. In one aspect, these multiple sites include multiple stimulation locations arranged proximally (e.g., location 230), midway (e.g. location 232), and distally (e.g., location 234) within vein 231 along the hypoglossal nerve 190, one or more stimulation locations on both the right and left hypoglossal nerves, and/or multiple stimulation locations (proximal 240, midportion 242, and distal 244) along another vein 235 adjacent to the hypoglossal nerve 190. While FIG. 4A depicts three stimulation sites or regions 190P, 190M, 190P on the target nerve, it is understood that embodiments of the present disclosure are employable to stimulate nerve 190 at any point (or multiple points) between (or distally beyond or proximally beyond) the identified regions 190P, 190M, 190P along nerve 190.

[0055] It is understood, as illustrated in FIG. 4B, that in some embodiments, a stimulation lead system 275 includes two or more stimulation leads 276, 277 that extend from an IPG 55 (FIGS. 1-2) to enable the separate leads 276, 277 to extend down each of the respective different transvenous pathways to enable two or more independent stimulation locations on a single target nerve from different veins, such as veins 231 and 235 (FIG. 2). In one aspect, each separate lead includes one, two, or more different electrode portions 280, 282, 284 spaced apart from each other along a length of the distal portion 279 of each lead 276, 277, as further illustrated in FIG. 4B. In some embodiments, the electrode portions 280, 282, 284 of each lead 276, 277 are arranged with a minimum distance (D1 or D2) therebetween such that the stimulation signal applied at one electrode portion is separate and independent from the stimulation signal applied at the other electrode portions to achieve independent stimulation sites along the same target nerve. Accordingly, the electrode portions of a distal portion of one lead are spaced apart such that when a stimulation signal from a first electrode portion (e.g., electrode portion 280) is applied at one site, the other respective sites are not stimulated by the first electrode portion. Of course, it is also understood that

each of the electrode portions 280, 282, 284 can be activated simultaneously to simultaneously apply a signal to each of the spaced apart, independent stimulation sites.

[0056] In some embodiments, the spacing D1 and D2 between the electrodes on the first lead 276 is equal to each other and the spacing D3 and D4 between the electrodes on the second lead 277 is equal to each other. In some other embodiments, the spacing D1 and D2 between the electrodes on the first lead 276 (or the spacing D3 and D4 between the electrodes on the second lead 277) is substantially different from each other. In some embodiments, the spacing (D1, D2) between the electrodes on the first lead 276 is the same as the spacing (D3, D4) between the respective electrode portions on the second lead 277. However, in other embodiments, the spacing (D1, D2) between the electrodes on the first lead 276 are the different than the spacing (D3, D4) between the electrode portions on the second lead 277 to account for the different distances traveled transvenously by the respective leads 276, 277 to locate the different respective electrode portions at desired stimulation sites.

[0057] It is understood that in other embodiments, the transvenously accessible stimulation sites along one or more nerves are spaced apart from each other by a distance that requires the application of stimulation signals to enable capturing the corresponding portion of the target nerve but wherein the spacing between adjacent stimulation sites along the nerve is close enough to allow some overlap between the adjacent stimulation signals.

[0058] In some embodiments, the separate stimulation leads 276, 277 of transvenous lead system 275 are positioned transvenously within different veins (e.g., 231 and 235 or a different set of veins) to stimulate different nerves. In this arrangement, one transvenous lead 276 stimulates a first nerve (such as nerve 190) and the other transvenous lead 277 stimulates a second nerve (not shown). In one aspect, each of the first and second nerves are associated with control of the respiratory system such that their selective stimulation relative to a respiratory pattern restores and maintains airway patency to alleviate obstructive sleep apnea.

[0059] Referring again to FIG. 3A, in some embodiments a nerve integrity monitor (stand alone monitor 190 or integrated into a sleep apnea physician programmer 108, such as programmer 108 in FIG. 2) is used to aide the physician in placing the electrode portion 156 of lead 150 in the proper location. In this regard, in one embodiment, the nerve integrity monitor comprises at least substantially the same features and attributes as the nerve integrity monitor described in U.S. Pat. No. 6,334,068, entitled INTRAOPERATIVE NEUROELECTROPHYSIOLOGICAL MONITOR, issued on Dec. 25, 2001, and which is hereby incorporated by reference in its entirety. In other embodiments, other nerve integrity monitors or an equivalent array of instruments (e.g., a stimulation probe and electromyography system) are used to apply the stimulation signal and evaluate the response of the muscle innervated by the target nerve.

[0060] In one embodiment, nerve integrity monitor 190 is further illustrated in FIG. 3B and comprises stimulation module 192 and a response module 194 that includes electromyography monitoring electronics (EMG) 196.

[0061] With this in mind, FIG. 3B further illustrates a response evaluation array 300, according to one embodiment of the present disclosure. As shown in FIG. 3B, response evaluation array 300 provides one or more mecha-

nisms to evaluate the effectiveness of a target site for stimulating a target nerve. In one embodiment, the array **300** includes: (1) observing or measuring the extent and location (an extension of the base of the tongue is preferred over extension of the tip) of tongue motor response **304**, such as but not limited to tongue protrusion (indicated by arrow P); (2) observing or measuring the extent of increased cross-sectional area (indicated by arrow W) of an upper respiratory airway **302**; (3) measuring the extent of an EMG response **306** (measured via EMG electronics **196** of monitor **190**) of one or more muscles upon stimulation applied at a potential target site within a vein; (4) observing or detecting a twitch of the tongue or laryngeal muscle; and/or (5) a substantial reduction in apnea events.

[0062] Accordingly, with this in mind, monitor **190** and one or more aspects of the response array **200** is used to evaluate the positioning of a lead within a vein relative to a potential stimulation site on a target nerve. In one aspect, a repetitive stimulation pattern is applied from the stimulation module **192** of nerve integrity monitor **190** to the electrode portion **156** of lead **150** as the lead **150** is advanced distally during navigation of the ranine vein (or other vein). In some embodiments, the applied stimulation pattern is a 1 second burst of stimulation every 3 seconds, a ramping stimulation pattern, and/or a physician controlled burst. In another aspect, electromyography (EMG) monitoring electronics **196** of the nerve integrity monitor **190** enables measuring a muscle response to the nerve stimulation applied during navigation of the target veins. Accordingly, fine wire electrodes **308** (or similar) are connected in electrical communication with the nerve integrity monitor **190** and are used to continuously monitor the muscle activity in response to the stimulation patterns applied via electrode portion **156** during navigation of the lead **150**. Using this arrangement, this closed loop feedback will allow the physician to obtain real-time feedback of a position (along the transvenous pathway) of the electrode leads **156** and feedback regarding the ability of the electrode leads **156** to capture the target nerve at a particular position of the electrode leads **156** along the transvenous pathway adjacent the target nerve. It is also understood that the methods described in association with FIGS. 1-3B for placement of lead **150** are applicable to placement of other leads described in association with FIGS. 4A-14.

[0063] In order to advance and deliver the electrode portion **156** of lead **150** to the target location, one embodiment of the present disclosure employs a delivery mechanism, such as one of the delivery mechanisms illustrated in FIGS. 5A-5B. In most instances, it is expected that the stimulation lead is introduced into a subclavian vein, however, other entry sites are not strictly excluded.

[0064] As illustrated in FIG. 5A, an over-the-wire lead system **200** includes an implantable lead **202** including at least one lumen (not shown) slidably advancable over a guide wire **204**. In use, distal end **206** of steerable guide wire **204** is advanced through the vasculature **180** (FIG. 3A) to the target location and then lead **202** is advanced over the proximal portion **205** of guide wire **204** (and along the length of guide wire **204**) until electrode portion **208** of lead **202** is located at the target stimulation site. In one aspect, lead **202** is in electrical communication with IPG **55** (FIG. 1) to enable IPG **55** to control operation of electrode portion **208** of lead **202**. It is also understood that once electrode portion **208** is located optimally along a length of the vein

(through which it extends), the lead **202** can be rotated to thereby rotate the electrode portion **208** to apply different stimulation effects to the various fascicles of the target nerve.

[0065] In another embodiment, a stylet-driven mechanism is employed to deliver electrode portion **156** of lead **150** to the target location to stimulate the hypoglossal nerve (or another target nerve). With this in mind, FIG. 5B illustrates a stylet lead system **220** that includes a lead **222** secured to a guide wire **224**. In use, distal end **226** of steerable lead **222** is advanced through the vasculature **180** via advancing and steering guide wire **224** until electrode portion **228** of lead **222** is located at the target stimulation site. In one aspect, lead **202** is in electrical communication with IPG **55** (FIG. 1) to enable IPG **55** to control operation of electrode portion **228** of lead **220**.

[0066] Referring again to FIG. 3A, in the one embodiment, lead **150** includes a lead body **152** that supports a respiratory sensor **154** (including first portion **155A** and second portion **155B**) at a proximal portion of lead body **152**. In other words, the respiratory sensor **154** is provided on the same lead body **152** as the electrode portion **156** so that both the respiratory sensor **154** and the electrode portion **156** are placed in the vasculature **180** in a single pass. With this arrangement, as the electrode portion **156** is advanced distally for placement adjacent a target nerve, the respiratory sensor **154** becomes automatically placed within a pectoral region of the patient **20** to enable sensing the respiration pattern of the thorax of the patient. With this placement, the sensor **154** detects respiratory features and/or patterns (e.g., inspiration, expiration, respiratory pause, etc.) in order to trigger activation of electrode portion **156** to stimulate a target nerve. Accordingly, with this arrangement, the IPG **55** (FIG. 1) receives sensor waveforms from the respiratory sensor **154**, thereby enabling the IPG **55** to deliver electrical stimulation synchronously with inspiration, such as with each respiratory breath (or another aspect of the respiratory pattern related to inspiration) according to a therapeutic treatment regimen in accordance with embodiments of the present disclosure. It is also understood that the respiratory sensor **154** is powered by the IPG **55** and the IPG **55** also contains internal circuitry to accept and process the impedance signal from the lead **150**.

[0067] In some embodiments, a respiratory waveform is monitored and stimulation (generally synchronous with respiration) is not applied until a respiratory feature and/or pattern indicative of an apnea is identified. Stimulation is terminated upon detection that the apneic-indicative feature or pattern is no longer present within the monitored respiratory waveform.

[0068] In one embodiment, the respiratory sensor **154** is an impedance sensor. In one aspect, the impedance sensor is configured to sense a bio-impedance signal or pattern whereby the control unit evaluates respiratory patterns within the bio-impedance signal. For bio-impedance sensing, in one embodiment, electric current will be injected through electrode **155B** and an electrically conductive portion of case **56** of the IPG **55** (FIG. 3A) and voltage will be sensed between electrode **155A** and **155B** (or also between **155A** and the electrically conductive portion of case **56** of IPG **55**) to compute the impedance.

[0069] In another embodiment of bio-impedance sensing, during the placement of the impedance sensing lead, the impedance waveform can be displayed on the programmer

(108) in real time. The location of electrodes 155A and 155B can be interactively (an array of electrodes would be available to select from via a multiplexer switch within the IPG) adjusted to yield the optimal signal to noise ratio in represent the respiratory phase information.

[0070] In another embodiment, the sensor 154 is a pressure sensor. In one aspect, the pressure sensor in this embodiment detects pressure in the thorax of the patient. In another aspect, this pressure could be a combination of thoracic pressure and cardiac pressure (e.g., blood flow). With this configuration, the controller is configured to analyze this pressure sensing information to detect the respiratory patterns of the patient.

[0071] In some embodiments, lead 150 includes an anchor 158 that is locatable at a proximal portion of lead body 152. The anchor 158 is configured to ensure that sensor 154 and electrode portion 156 remain in the proper position within the vasculature 180.

[0072] The previously introduced FIGS. 1 and 3A generally depict a stimulation electrode portion 65,156 transvenously delivered into the ranine vein (i.e., the vena comitans of the hypoglossal nerve) to enable stimulating the hypoglossal nerve to treat sleep apnea. In one embodiment of the present disclosure, as illustrated in FIG. 6, a method 250 of treating apnea includes identifying an optimal site to locate stimulation electrode portion 156 (FIG. 3A) along a length of the ranine vein (or another vein suitable to apply stimulation to the hypoglossal nerve or another target nerve) that will result in a desired stimulation of the hypoglossal nerve. In particular, as illustrated in FIG. 6, in a first step 252 the lead 150 is advanced through the vasculature 180 (FIG. 3A) to a range of target sites within the ranine vein (or other nearby vein) and a pre-determined electrical stimulus is applied at each potential target site along the ranine vein (at 254). As illustrated at 256, upon the application of the electrical stimulus at each potential target site, the response to the stimulation is identified by: (1) a degree of tongue protrusion; (2) the size of cross-sectional area of the upper airway; (3) a best EMG response indicative of maintaining airway patency; and/or 4) a twitch from either the tongue or laryngeal muscle. As illustrated at 258, using the response data for each potential target site, the method 250 identifies one or more treatment sites (from among the potential target sites along the ranine vein) correlated with the greatest impact on maintaining airway patency during inspiration.

[0073] It is also understood that these steps 252-258 can be repeated iteratively, as necessary, until the optimal vein and the optimal stimulation location along that vein are identified. With this in mind, in employing method 250, one or more venous pathways might be explored before one or more veins (and a location along that vein(s)) are identified as being an optimal site(s) from which to apply an electrical stimulus. In other words, method 250 is not limited to evaluating target sites within a single vein adjacent a target nerve, but extends to evaluating several different veins adjacent to one or more target nerves. In this regard, method 250 is employed to identify the vein from among a group of veins that enables providing the most efficacious stimulus to a target nerve (e.g., nerves innervating the muscles of the upper airway including the genioglossal, hypoglossus, palatoglossus, etc.), and to identify the best location along one of the those sites to provide the most efficacious stimulus. As previously mentioned, in some embodiments,

more than one vein is identified and used so that a stimulation signal is applied from two different veins toward the target nerve.

[0074] In one aspect, in evaluating multiple potential stimulation sites along a vein or along multiple veins, at each site the method 250 iteratively applies a stimulation signal with differing values for each signal parameter (e.g., polarity, pulse width, frequency, and amplitude) to determine which combination of values yields the best impact of the stimulation signal upon the target nerve at a potential site. In this way, each potential site is evaluated under conditions in which the stimulation signal would actually be applied were that potential site chosen as an optimal site for stimulation. In one embodiment, this determination of an optimal stimulation site via evaluating each of the stimulation parameters employs therapy module 106 in cooperation with stimulation module 104, a stimulation lead 150, and patient programming module 108, as previously described in association with FIGS. 1-3A.

[0075] FIG. 7 illustrates a stimulation lead system 350 to be deployed instead of lead 150, according to one embodiment of the present disclosure. Lead system 350 comprises substantially the same features and attributes as lead 150 (FIG. 3) except for providing the sensing portion along a separate lead body 382 from the lead body 352 that supports a stimulation electrode portion (not shown, but similar to electrode portion 156 in FIG. 3A). Accordingly, as illustrated in FIG. 7, lead system 350 includes a pair of lead bodies 352 and 382 with lead body 352 dedicated to supporting the stimulation electrodes and with lead body 382 dedicated to support the sensor 354. The lead body 382 supports sensor 354, including first portion 355A and second portion 355B spaced apart from each other along a length of lead body 382. In one embodiment, the lead body 382 has a length configured to orient both the first portion 355A and the second portion 355B within the subclavian vein 182. However, in other embodiments, the lead body has a length configured to orient one or both of the first portion 355A and the second portion 355B within one or more portions 189 of the vasculature 180 beyond the subclavian vein 182. In any case, sensor 354 is configured to monitor respiratory effort to detect patterns indicative of apneas/hypopneas, and to detect the patterns of inspiration, expiration, and/or respiratory pause, which may be used to trigger a therapeutic stimulation.

[0076] In some embodiments, sensor lead 382 of lead system 350 is not placed transvenously but is implanted subcutaneously, either adjacent to the pocket housing the IPG 55 or tunneled within tissue in the pectoral region surrounding the IPG 55. In other embodiments, sensor lead 382 additionally comprises a cardiac lead (epicardial or intra-cardiac) that is also used for a cardiac therapy (for example, therapies such as bradycardia, tachycardia, or heart failure).

[0077] While various different shapes and forms of leads can be used in the methods and systems of the present disclosure, FIGS. 8-14 illustrate several different exemplary embodiments of leads. In at least some of these embodiments, a fixation mechanism provides releasable fixation for a stimulation lead so that transvenous placement of a stimulation lead can be maintained for semi-permanent time period or can be reversed (i.e., removed) if necessary.

[0078] FIG. 8 is a side plan view schematically illustrating a lead 400 including a lead body 402 having a proximal

portion **404** and a distal portion **406**, which supports a stimulation electrode array **409**. The electrode array **409** includes one or more surface electrodes **410** spaced apart along a length of the distal portion **406** of the lead body **402**. In some embodiments, lead **400** includes an anchor **408** at the proximal portion **404** of lead body **402**, which is configured to maintain the position of the lead body **402** relative to a length of the vein(s) through which the lead body **402** extends. In one aspect, this anchor **408** facilitates maintaining the position of the stimulation electrode array **409** at a desired site within the vein adjacent a desired stimulation site of the target nerve.

**[0079]** Once implanted, a transvenous stimulation system for automatically treating obstructive sleep apnea must remain stable and endure the normal activities of the patient. For example, the neck of a patient moves through a wide range of motion through many different positions. To counteract the potential for a stimulation lead to move back and forth within a vein (relative to a desired stimulation site), embodiments of the present disclosure provide an anchoring mechanism to anchor a distal portion of a stimulation lead within a vein at the desired stimulation site relative to a target nerve. These anchoring mechanisms insure that proper placement of the stimulation lead is maintained despite the dynamic motion and varying positions of the neck, which could otherwise cause inadvertent repositioning of the stimulation lead (relative to the target nerve) if the distal anchoring mechanisms were not present. Several embodiments of a distal anchoring mechanism are described and illustrated in association with FIGS. **9** and **11-14**.

**[0080]** FIG. **9** is a side plan view schematically illustrating a lead **430** including a distal anchoring mechanism, in accordance with one embodiment of the present disclosure. In this embodiment, a lead **430** includes a lead body **432** having a proximal portion **434** and a distal portion **436**, which supports a stimulation electrode array **439**, as illustrated in FIG. **9**. The electrode array **439** includes one or more surface electrodes **440** spaced apart along a length of the distal portion **436** of the lead body **432**. In another aspect, distal portion **436** of lead body **432** comprises a distal anchoring mechanism arranged as a coiled configuration **450** and which is configured to maintain the position of the lead body **402** relative to a length of the vein(s) through which the lead body **402** extends. This coiled configuration acts to fix the distal portion **436** of the lead body **432** within the vein at the location at which the electrodes **440** will apply an electrical stimulus. In one aspect, prior to insertion of the lead **430** into the venous system, the distal portion **436** is in the coiled configuration **450**. However, in order to install the lead **432** into the venous system, the distal portion **436** is converted from the coiled configuration **450** into a generally straight configuration (i.e., lacking coils) by advancing the guide wire through at least the distal portion **436** of the lead body **432**. After maneuvering the guide wire and the lead **430** to the desired location within the venous system, the guide wire is removed proximally from the lead body **432**, which allows the distal portion **436** to return to the coiled configuration **450**. In one embodiment, this “memory effect” of the coiled configuration is achieved via incorporating materials such as Nitonal or thermo-formed polyurethane into the distal portion **436**. In other embodiments, other materials having memory behavior, as known by those skilled in the art, are employed to form distal portion **436**, thereby enabling the operation of coiled configuration **450**.

**[0081]** In another aspect, as previously described in connection with method **250**, each of the various stimulation parameters (for example, electrode polarity, amplitude, frequency, pulse width, and duration) are tested at each potential stimulation site as the stimulation lead **430** is maneuvered (through the venous system) adjacent to the target nerve. By evaluating the response at each location along the venous system (in the target nerve region) and noting the particular value or combination of stimulation parameters that yields the best response at that potential location, one can determine the optimal stimulation site for stimulation electrode array **439**. As previously described herein, this method of determining a stimulation site (according to an effective group of corresponding values for the stimulation parameters) can be applied to anyone of the different stimulation electrode configurations within this present disclosure.

**[0082]** In another embodiment of the stimulation leads and as previously described in association with FIGS. **1-4B**, two individual branches of the stimulation lead or two independent stimulation leads can be placed transvenously near both left and right side of the hypoglossal nerve. The IPG and programmer can control stimulation delivery to each branch of the stimulation lead either independently or dependently.

**[0083]** FIG. **10** is a perspective view illustrating another embodiment of the present disclosure. In this embodiment, a lead **500** includes an array of ring electrodes **502**, **504**, **506** at a distal portion of the lead **500** and which is configured to apply an electrical stimulus to a target nerve. In one aspect, this array of ring electrodes **502-506** is configured to direct an electrical field to a target nerve (e.g., hypoglossal nerve) spaced apart from the lead **500** within the vein (e.g., ranine vein). It is also understood that the ring electrodes **502-506** can be optionally employed in one or more of the other embodiments described in association with FIGS. **8-9** and **11-14**.

**[0084]** FIG. **11** is a perspective view schematically illustrating a lead **520** including a distal anchoring mechanism, in accordance with one embodiment of the present disclosure. In this embodiment, the lead **520** includes a stent portion **522** at a distal portion of the lead **520**, and in which the stent portion **522** includes one or more stimulation electrodes **524**, **526**, **528** incorporated into (or added onto) the structure (e.g., struts) of the stent. In one aspect, this array of electrodes **524-528** supported by the stent structure **522** is configured to direct an electrical field to a target nerve (e.g., hypoglossal nerve) spaced apart from the lead **500** within the vein (e.g., ranine vein). Moreover, the stent structure **522** provides a mechanism to secure the location of the electrodes **524-528** at a desired placement along a length of the vein (through which the lead **520** extends) corresponding to a desired stimulation site of a target nerve.

**[0085]** In one embodiment, the stent structure **522** is arranged in a collapsed state (having a diameter generally represented by A in FIG. **11**) during insertion into the venous system and the vein adjacent the target nerve. Once the stent structure **522** and associated stimulation electrodes are located a potential stimulation site, the physician initiates conversion of the stent structure **522** from its collapsed state to an expanded state (having a diameter generally represented by B in FIG. **11**) to contact the walls of the vein, which in turn, anchors the electrodes in place. In other words, the stent structure **522** acts as a distal fixation

mechanism that fixates the distal portion of the lead within the vein at the desired stimulation site. In one aspect, during the process of evaluating different potential stimulation sites, the stent structure is temporarily expanded to test the effectiveness of a stimulation signal at a potential stimulation site and then re-collapsed to enable repositioning the lead 520 along the vein to place the electrodes and stent structure at a different potential stimulation site. This process is repeated as many times as necessary until the optimal stimulation site is determined, where the stent structure 522 is then re-expanded to secure and maintain the distal portion of the lead 520 at the optimal stimulation site. It is understood that the selective expansion, collapse, and final fixation of the stent structure in an expanded state is performed according to techniques known in the art, such as manipulating the stent structure 522 via rotation, pushing, and/or pulling of a guide wire.

[0086] In other embodiments, instead of using the coiled configuration 350 of FIG. 9 or the stent structure of FIG. 11, fixation of a distal portion of a stimulation lead within a vein is achieved via other mechanisms.

[0087] FIGS. 12A-12B schematically illustrate a trans-venous stimulation lead 530 including a distal fixation mechanism, according to one embodiment of the present disclosure. As illustrated in FIG. 12A, a distal portion 531 of the stimulation lead 530 includes a distal fixation mechanism provided via an array 532 of deployable tines 534. In FIG. 12A, tines 534 are shown in a deployed configuration in which tines 534 extend radially from the body of distal portion 531 of lead 530. In this position, the tines 534 are configured to releasably engage the walls of a vein to thereby anchor the distal portion 531 within the vein. It is understood that the tines are configured in a manner as to not negatively impact the integrity of the walls of the vein.

[0088] In one aspect, as the distal portion of the lead is advanced through the venous system, a guidewire is used to position these tines 534 into a storage position generally against an outer wall of the lead, as schematically illustrated in FIG. 12B. After a suitable stimulation site has been determined, the tines 534 are deployed (i.e., selectively expanded radially outward away from the outer wall of the lead as shown in FIG. 12A) to engage the walls of the vein to thereby anchor the distal portion 531 of the lead at the desired stimulation site along that vein (and adjacent to the desired location along the target nerve). In some embodiments, the deployable tines 534 are made of a polyurethane material and/or a Nitinol spring.

[0089] It is understood that the array 532 of tines 534 is located on distal portion 531 of lead 530 at a position sufficiently close to an electrode stimulation portion of lead 530 (such as one of the electrode configurations illustrated throughout this application) to insure that the electrode stimulation portion is generally fixed within a vein at a location corresponding to a desired stimulation site of a target nerve.

[0090] FIG. 13 is a perspective view illustrating a trans-venous stimulation lead 540 configured to apply an electrical stimulus to a target nerve, according to another embodiment of the present disclosure. In this embodiment, the lead 540 includes a series 541 of programmable arrays 542, 544, 546 of electrode portions 548 with the respective arrays 542, 544, 546 spaced apart from each other along a length of the distal portion of the lead 540. In one aspect, the respective electrode portions 548 of each array extend circumferen-

tially about an outer surface of lead 540 in a spaced apart relationship to form a general ring-shaped configuration. In one aspect, the programmable arrays 542-546 of electrode portions 548 are configured to direct an electrical field from a location within the vein (e.g., ranine vein) to a target nerve (e.g., hypoglossal nerve) spaced apart from the lead 540. It is also understood that the arrays 542-546 of electrodes can be optionally employed in one or more of the other embodiments described in association with FIGS. 8-9 and 11-12B.

[0091] In one embodiment, each array 542, 544, 546 of electrodes comprises two, three, four or more independent electrode portions 548. In one aspect, the electrode portions 548 are independently programmed to stimulation the target stimulation site. In other words, at any given time, a stimulation signal is applied from zero, one, two, or more electrode portions 548 of each separate array 542-546. In this embodiment, the many varied positions of the electrode portions both along the length of the distal portion of the lead 540 and circumferentially or radially about the lead 540 enables precise activation of selective groups of electrode portions 548 (at their various spaced apart locations) to produce a stimulation signal at virtually any point relative to the distal portion of lead 540. Accordingly, this arrangement enables stimulation of a target nerve (or select portions/fascicles of a target nerve) with little or no rotation of the lead 540 to direct the stimulation to the target stimulation site.

[0092] FIG. 14 is a perspective view illustrating a trans-venous stimulation lead 560 configured to apply an electrical stimulus to a target nerve, according to another embodiment of the present disclosure. In this embodiment, a lead 560 includes a programmable array of ring electrodes 562 mounted at a distal portion 564 of the lead 560. In one aspect, this programmable array of ring electrodes 562 is configured to direct an electrical field from the location of the respective ring electrodes 562 within the vein (e.g., ranine vein) to a target nerve (e.g., hypoglossal nerve) spaced apart from the lead 560. It is also understood that the ring electrodes 562 can be optionally employed in one or more of the other embodiments described in association with FIGS. 8-9 and 11-12B. In one embodiment, each ring 562 may be independently programmed to stimulate the target stimulation site. In this embodiment, the many varied positions of the ring electrodes 562 along the length of the distal portion of the lead 560 enables precise activation one, two, or more ring electrodes 562 (at their various spaced apart locations) to produce a stimulation signal at virtually any point along a length of the distal portion of lead 560. Accordingly, this arrangement enables stimulation of a target nerve with little or no rotation of the lead 560 to direct the stimulation to the target stimulation site. Moreover, once lead 560 is located generally in the region of interest, the lead 560 need not be maneuvered extensively distally or proximally within the vein in order to position an electrode adjacent to a desired stimulation site of a nerve because any one or combination of the ring electrodes 562 along the length of the distal portion of the lead are available for activation to apply a stimulation signal to the target nerve. In one embodiment, the array of electrodes 562 has a length that substantially matches a majority of a length of the hypoglossal nerve, as it extends from a position near the jugular vein toward the genioglossus muscle. In one aspect, this length of the array enables determining which electrodes 562 of the array produce the most efficacious respiratory

airway patency without having to reposition the array within the vasculature. In another aspect, an efficacious respiratory airway patency is determined upon identifying which ring electrode **562** or combination of ring electrodes **562** produces a longest duration of increased airway patency, a largest size of increased airway patency, and/or a substantial reduction in apneas.

[0093] In this embodiment, the lead does not require rotation of the lead to direct the stimulation to the target stimulation site. Further with multiple rings attached the control unit, minimal positioning of the lead within the vein is required as optimal stimulation settings may be evaluated using multiple combinations of active or inactive electrode rings.

[0094] Several different embodiments have been described in association with FIGS. 1-7, in which an IPG **55** is implanted in a pectoral region and in which a sensor electrode(s) and a stimulation electrode(s) (extending from the IPG **55**) are delivered transvenously to sense respiratory patterns and to apply a stimulation signal, respectively. In addition, several embodiments of stimulation electrode arrays (and associated distal fixation mechanisms) have been described in association with FIGS. 8-14. Moreover, it is understood that in some embodiments, a lead is transvenously placed in each side of the body (left and right) such that bilateral (simultaneous or alternating) stimulation takes place on the left and/or right hypoglossal nerve (or other target nerve). With these various embodiments in mind, it is further understood that among those embodiments, several configurations are provided in which at least two electrodes are spaced apart in the body in the vicinity of the upper airway such that an impedance is measurable between the two spaced apart electrodes to provide an indication of airway patency (e.g., opening and/or closing of the upper airway). For example, to measure this impedance, one of the stimulations electrodes is placed transvenously on a first side of the body and the other one of the stimulation electrodes is placed transvenously on a second side of the body. In some embodiments, this bio-impedance is measured as a trans-thoracic bio-impedance, a trans-laryngeal bio-impedance, impedance, or a trans-pharyngeal bio-impedance.

[0095] In some configurations, the spaced electrodes are both stimulation electrodes, while in other configurations, the spaced apart electrodes comprise one stimulation electrode and one respiratory sensor electrode. In yet other configurations, the two spaced apart electrodes (used for measuring an impedance indicative of airway patency) include one of the electrodes comprising at least one of a stimulation electrode and a respiratory sensor electrode and the other one of the electrodes comprising an electrode formed by an electrically conductive portion of a case **56** or housing of the IPG **55**.

[0096] Moreover, in some embodiments, the respective electrodes portions provide a dual function in that each electrode provides a respiratory sensing function or a stimulation function as well as acting as a part of a pair of impedance sensing electrodes. On the other hand, in other embodiments, at least one electrode of the pair of impedance sensing electrodes does not also act to sense respiration (e.g. inspiration) or to stimulate but rather is dedicated for use in sensing impedance to detect or indicate a degree of airway patency.

[0097] Accordingly, by using a pair of electrodes to sense an impedance that is indicative of airway patency, a system

operating according principles of the present disclosure enables detection of apnea event by indicating whether or not a collapse of the airway has taken place. In one embodiment, this impedance-based indication of airway patency is used along with other physiologic sensing information (such as the sensing information described at least in association with FIGS. 2A-2B) to detect an apnea event, and to potentially trigger stimulation of a target nerve to restore airway patency in accordance with the embodiments of the present disclosure.

[0098] FIG. 15A is a side plan view schematically illustrating a nerve stimulation system **600** for treating obstructive sleep apnea, according to an embodiment of the present disclosure. In this embodiment, as illustrated in FIG. 15A, system **600** provides therapy to a patient **602** reclined on a support **604** (e.g. a bed) and a headrest structure **606** (e.g., pillow), which houses a power source/controller **622** and one or more radiofrequency transmission coils **620**. However, it is understood that this embodiment is not strictly limited to a bed **604** and/or pillow, but extends to other furniture configurations in which the patient **602** can remain stationary for an extended period of time. As further illustrated in FIG. 15A, system **600** includes a microstimulator **635** which is delivered transvenously into the ranine vein **188** (or other nearby vein) for stimulating the hypoglossal nerve **190** (or other target nerve), as illustrated in FIG. 15B. In some embodiments, transvenous delivery of microstimulator **635** is accomplished via techniques substantially similar to those previously described in association with FIGS. 9, 11, 12A-12B, as well as via transvenous delivery methods to be further described in association with FIGS. 16-17C.

[0099] In one embodiment, microstimulator **635** comprises a generally elongate member including circuitry for generating a neurostimulation signal and at least one electrode **637** arranged on a surface of the micro stimulator **635** for transmitting the signal to nerve **190**, as illustrated in FIG. 15B. In some embodiments, microstimulator **635** comprises a microminiature electronic device such as that described in Richmond et al. U.S. Pat. No. 6,240,316, and which is hereby incorporated by reference in its entirety. However, it is understood that in the context of the present disclosure, such micro stimulators are delivered transvenously instead of being directly implanted into a target muscle.

[0100] In general terms, system **600** applies a treatment regimen for treating obstructive sleep apnea according to sensing methods and stimulation parameters at least substantially the same as those previously described in association with FIGS. 1-14, including the potential use of bilateral stimulation (for simultaneous or alternate stimulation from the left and right sides of the body) via the use of two separate microstimulators.

[0101] Referring again to FIG. 15A, system **600** includes at least one sensing component configured to provide respiratory sensing suitable for detection of an apnea and for triggering application of the stimulation signal synchronous with respiration, such as with inspiration. In some embodiments, respiratory sensing is provided via an externally securable belt **630** including a respiratory pressure sensor **631**. Signals sensed at sensor **631** are transmitted wirelessly to power/controller **622** for use in apnea detection and treatment. In other embodiments, respiratory sensing is provided via an impedance sensor **640** which is secured on an external surface of a chest via a patch or even implanted subcutaneously. Sensor **640** communicates wirelessly with

power/controller 622. In some embodiments, belt 630 or the other sensor 640 includes an accelerometer or piezoelectric transducer for detecting body motion/position, with such information also being used by controller 622 and/or microstimulator 635 to determine when to monitor for apneas and/or when to treat apneas.

[0102] In use, as the patient reclines on the support 604, respiratory sensor 631 or 640 provides information about respiratory effort which is monitored via a power/controller 622. Once a treatment threshold is detected, power/controller 622 generates power which is communicated to microstimulator 635 via radiofrequency/transmission coils 620. It is also understood that in some embodiments, microstimulator 635 stores programmed instructions for applying a stimulation signal according to an obstructive sleep apnea treatment regimen, while in other embodiments microstimulator 635 receives such programmed instructions from controller 622 via coils 620. In either case, the instructions are also programmable by a clinician or by a patient (within certain physician-authorized constraints). With this in mind, the microstimulator 635, in turn, selectively stimulates nerve 190 (FIG. 15B) according to a treatment regimen to restore airway patency, thereby alleviating the obstructive sleep apnea.

[0103] In some embodiments, as illustrated in FIG. 15C, respiratory sensing information is obtained via sensors arranged on a garment 675 configured to be worn by the patient 602 during a time period when apneas might potentially occur (e.g. sleeping, resting). In one embodiment, garment 675 provides a respiration sensing belt 682 similar to belt 630, while in other embodiments garment 675 comprises one or more impedance sensors or other respiratory effort sensors 684 (and/or body motion/position detectors) on a pectoral region 680 of the garment 675.

[0104] FIG. 16 is a side plan view schematically illustrating an anchoring system of a transvenously delivered microstimulator, according to an embodiment of the present disclosure. Accordingly, in some embodiments, as illustrated in FIG. 16, a transvenous delivery mechanism 700 includes a steerable catheter/stylet 710 including a proximal portion 714 and a distal portion 712. The micro stimulator 635 is releasably secured at distal portion 712 of steerable catheter/stylet 710 via release mechanism 730. Using techniques known to those skilled in the art, catheter 710 is used to advance and maneuver the microstimulator 635 transvenously until adjacent to a desired stimulation site of a target nerve. At this location, the release mechanism 730 is activated to secure micro stimulator 635 within the vein adjacent the target nerve and the remainder the catheter 710 is then withdrawn from the vein leaving the microstimulator 635 within the vein. While various mechanisms can be used to secure the microstimulator 635 within the vein, in this embodiment, an array of selectively deployable tines 720 (or other selectively deployable anchors) extends radially outward from micro stimulator 635 to secure the microstimulator 635 relative to the vein and, thereby relative to the target nerve.

[0105] FIG. 17A is a side plan view schematically illustrating a stent-based anchoring system of a transvenously delivered microstimulator configured to treat obstructive sleep apnea, according to an embodiment of the present disclosure. In this embodiment, a microstimulator 635 is coupled to a stent 770. A steerable catheter/stylet 760 is adapted to transvenously deliver (using techniques known to

those skilled in the art) the combination of the stent 770 (in its collapsed state) and the microstimulator 635 to a location within a vein adjacent a target nerve. Further manipulation of the steerable catheter 760 results in release and expansion of the stent 770 to be secured relative to the walls of the vein and then withdrawal of the catheter/stylet 760. With this arrangement, the microstimulator 635 becomes generally fixed relative to a length of the vein and therefore generally fixed relative to a portion of the target nerve.

[0106] In some embodiments, micro stimulator 635 is coupled to extend within an interior 771 of stent 770, as illustrated in FIG. 17B. In one embodiment, micro stimulator 635 is coupled relative to the stent 770 via one or more semi-rigid or resilient tethers 772.

[0107] In yet other embodiments, microstimulator 635 is configured to extend distally forward from (or proximally relative to) an end 773 of stent 770 via support 782 (which extends from one or more struts 774), as illustrated in FIG. 17C. accordingly, in this arrangement, microstimulator 635 is not located within the interior 771 (FIG. 17B) of stent 770, which may lessen any potential interference of the body of stent 770 relative to the stimulation signal from microstimulator 635.

[0108] Embodiments of the transvenously-delivered microstimulator (described herein) enable precise location of a microstimulator adjacent to an optimal neurostimulation site because the transvenous approach enables the surgeon to vary the position of the microstimulator along the length of a vein (using the steerable catheter techniques) and thereby vary the position of the microstimulator along the length of the target nerve. This method allows the surgeon to identify a precise optimal stimulation site that causes contraction of one or more specific muscles (suited to restore airway patency) prior to fixing the location of the micro stimulator relative to the target nerve. Moreover, steerable catheter/stylets or other transvenous delivery instruments enable rotation of the microstimulator within the vein to further adjust the effect of the stimulation on a target nerve or portions of the target nerve.

[0109] Embodiments of the present disclosure provide an implantable system to provide therapeutic solutions for patients diagnosed with obstructive sleep apnea. The system is designed to stimulate the hypoglossal nerve during inspiration thereby preventing occlusions in the upper airway during sleep.

[0110] While at least one exemplary embodiment has been presented in the foregoing detailed description, it should be appreciated that variations exist. It should also be appreciated that the exemplary embodiment or exemplary embodiments are only examples, and are not intended to limit the scope, applicability, or configuration of the present disclosure in any way. Rather, the foregoing detailed description will provide those skilled in the art with a convenient road map for implementing the exemplary embodiment or exemplary embodiments. It should be understood that various changes can be made in the function and arrangement of elements without departing from the scope of the present disclosure as set forth in the appended claims and the legal equivalents thereof.

1. A method of treating obstructive sleep apnea, comprising:  
removably supporting a microstimulator on a distal portion of a catheter;

- inserting and advancing the catheter through the vasculature to position the microstimulator in close proximity to a hypoglossal nerve;
- anchoring the microstimulator within the vasculature in close proximity to the hypoglossal nerve and removing the catheter from the vasculature;
- applying, via the microstimulator, a nerve-stimulation signal to the hypoglossal nerve.
2. The method of claim 1, comprising monitoring a respiration pattern via at least one of:
- a sensing portion of a lead positioned within an upper body portion of a patient; or
  - a respiration sensor externally attached to the body.
3. The method of claim 2, comprising:
- synchronizing application of the nerve-stimulation signal with respiration.
4. The method of claim 2, wherein applying the nerve-stimulation signal comprises:
- detecting, within the monitored respiratory pattern, an apneic-indicative pattern prior to applying the nerve-stimulation signal;
  - synchronizing the application of the nerve-stimulation signal with respiration; and
  - discontinuing application of the nerve-stimulation signal when the apneic-indicative pattern is no longer detected within the monitored respiratory pattern.
5. The method of claim 4, comprising:
- monitoring an awake/sleep state.
6. The method of claim 1, comprising:
- removably supporting a structure at the distal portion of the catheter, including securing the microstimulator relative to the structure,
  - wherein advancing the catheter includes maintaining the structure in a deactivated state,
  - wherein anchoring the microstimulator includes deploying the structure into an activated state, in which the structure engages a side wall of the vasculature.
7. The method of claim 6, wherein the structure comprises a tine structure.
8. The method of claim 6, wherein the structure comprises a stent.
9. The method of claim 1, comprising:
- removably supporting a stent at the distal portion of the catheter, including securing the microstimulator relative to the stent,
  - wherein advancing the catheter includes maintaining the stent in a deactivated state, in which the stent has a compressed, first diameter sized less than a diameter of the vasculature at which the stimulation portion is positioned in close proximity to the hypoglossal nerve,
  - wherein anchoring the microstimulator includes deploying the stent structure into an activated state, in which the stent has an expanded, second diameter sized greater than the diameter of the vasculature at which the stimulation portion is positioned in close proximity to the hypoglossal nerve.
10. The method of claim 9, comprising:
- providing the stent as an array of struts assembled into a generally tubular structure with the microstimulator secured to an outer surface of the generally tubular structure.
11. The method of claim 9, comprising:
- providing the stent as an array of struts assembled into a generally tubular structure with the microstimulator suspended within an interior of the generally tubular structure.
12. The method of claim 1, comprising:
- placing a respiratory sensor external to a patient's body; and
  - detecting the apneic-type respiration pattern via the external respiratory sensor.
13. The method of claim 12, wherein placing the respiratory sensor externally comprises directly securing the respiratory sensor relative to the patient's body.
14. The method of claim 1, comprising:
- providing a power supply, a controller, and a power transmission mechanism in a first portion of a patient support;
  - placing the patient's body on a first portion and a second portion of the patient support while positioning the microstimulator in the patient's body in close proximity to the power transmission mechanism of the patient support; and
  - employing the power supply and controller to wirelessly transmit power, via the power transmission mechanism, to the microstimulator.
15. The method of claim 14, comprising:
- providing the first portion of the patient support as a headrest structure; and
  - positioning the power transmission mechanism at an upper portion of the headrest structure.
16. An obstructive sleep apnea treatment system comprising:
- a respiratory sensor removably securable to an exterior of a patient's body; and
  - a microstimulator configured to be transvenously delivered proximate to a hypoglossal nerve and including:
    - an anchor mechanism configured to anchor the microstimulator within the vasculature proximate the hypoglossal nerve; and
    - circuitry configured to generate a neurostimulation signal.
17. The system of claim 16, comprising:
- a patient support housing a power supply, a controller, and a transmission mechanism configured to wirelessly transmit power to the microstimulator upon positioning of the patient support in close proximity to the microstimulator.
18. The system of claim 16, wherein the anchor mechanism comprises:
- a tine structure including a base portion and a plurality of tines extending from the base portion, wherein the microstimulator is secured to base portion,
  - wherein the tine structure is movable between:
    - a deactivated state, in which the respective tines extend generally parallel to a longitudinal axis of the microstimulator; and
    - an activated state, in which the tines protrude generally outward from the microstimulator to engage a side wall of the vasculature.
19. The system of claim 16, wherein the anchor mechanism comprises:
- a stent, wherein the stent is movable between:
    - a deactivated state, in which the stent has a compressed, first diameter sized less than a diameter of the

vasculature at which the microstimulator is positioned in close proximity to the hypoglossal nerve; and

an activated state, in which the stent has an expanded, second diameter sized greater than the diameter of the vasculature at which the stimulation portion is positioned in close proximity to the hypoglossal nerve.

**20.** The system of claim **19**, wherein the stent comprises an array of struts defining a generally tubular structure, and wherein the microstimulator is secured to an outer surface of the generally tubular structure.

**21.** The system of claim **19**, wherein the stent comprises an array of struts defining a generally tubular structure, and wherein the microstimulator is secured via a tether to one or more respective struts to be suspended in at a position within an interior of the generally tubular structure.

\* \* \* \* \*

专利名称(译)	经静脉治疗睡眠呼吸暂停的方法		
公开(公告)号	<a href="#">US20180296829A1</a>	公开(公告)日	2018-10-18
申请号	US15/894484	申请日	2018-02-12
申请(专利权)人(译)	INSPIRE医疗系统, INC.		
当前申请(专利权)人(译)	INSPIRE医疗系统, INC.		
[标]发明人	NI QUAN CHRISTOPHERSON MARK A HERBERT TIMOTHY P RONDONI JOHN		
发明人	NI, QUAN CHRISTOPHERSON, MARK A. HERBERT, TIMOTHY P. RONDONI, JOHN		
IPC分类号	A61N1/36 A61B5/00 A61F2/848 A61F2/86 A61N1/372		
CPC分类号	A61N1/37205 A61F2/86 A61N1/3601 A61B5/4818 A61F2/848		
优先权	13/121862 2011-04-29 US PCT/US2009/059060 2009-09-30 WO 61/101952 2008-10-01 US		
外部链接	<a href="#">Espacenet</a> <a href="#">USPTO</a>		

摘要(译)

用于治疗睡眠呼吸暂停的系统和方法包括将可植入脉冲发生器皮下插入患者体内并将引线连接到脉冲发生器。将导线插入脉管系统内并通过脉管系统经静脉推进，直到导线的刺激部分位于靠近舌下神经的位置。通过引线的刺激部分将神经刺激信号施加到舌下神经。

