



(19) **United States**

(12) **Patent Application Publication**
An et al.

(10) **Pub. No.: US 2018/0192894 A1**
(43) **Pub. Date: Jul. 12, 2018**

(54) **RISK STRATIFICATION BASED HEART FAILURE DETECTION ALGORITHM**

A61B 5/024 (2006.01)

G16H 50/50 (2018.01)

A61N 1/372 (2006.01)

A61B 5/08 (2006.01)

(71) Applicant: **Cardiac Pacemakers, Inc.**, St. Paul, MN (US)

(52) **U.S. Cl.**

CPC *A61B 5/0205* (2013.01); *G16H 50/30*

(2018.01); *G06Q 10/00* (2013.01); *A61B*

5/4842 (2013.01); *A61B 5/7275* (2013.01);

G06Q 50/22 (2013.01); *A61B 5/0816*

(2013.01); *A61B 5/0031* (2013.01); *A61B*

5/02007 (2013.01); *A61B 5/024* (2013.01);

G16H 50/50 (2018.01); *A61N 1/37282*

(2013.01); *G16H 50/20* (2018.01)

(72) Inventors: **Qi An**, Blaine, MN (US); **Pramodsingh Hirasingh Thakur**, Woodbury, MN (US); **Viktorina A. Averina**, Shoreview, MN (US); **Yi Zhang**, Plymouth, MN (US); **Robert J. Sweeney**, Woodbury, MN (US)

(21) Appl. No.: **15/911,856**

(22) Filed: **Mar. 5, 2018**

(57) **ABSTRACT**

Related U.S. Application Data

(63) Continuation of application No. 13/726,786, filed on Dec. 26, 2012, now Pat. No. 9,968,266, which is a continuation-in-part of application No. 11/616,430, filed on Dec. 27, 2006, now Pat. No. 8,768,718.

Publication Classification

(51) **Int. Cl.**

A61B 5/0205 (2006.01)

G16H 50/30 (2018.01)

G06Q 10/00 (2012.01)

A61B 5/00 (2006.01)

G06Q 50/22 (2018.01)

G16H 50/20 (2018.01)

A61B 5/02 (2006.01)

A system comprises a risk analysis module and a worsening heart failure (WHF) detection module. The risk analysis module measures at least one first physiological parameter of a subject using a physiological sensor of an ambulatory medical device, and determines a heart failure (HF) risk score for the subject according to the at least one measured first physiological parameter. The HF risk score indicates susceptibility of the subject to experiencing a HF event. The WHF detection module measures at least one second physiological parameter of the subject using the same or different physiological sensor, and generates an indication of prediction that the subject will experience a WHF event when the at least one second physiological parameter satisfies a WHF detection algorithm. The risk analysis module adjusts generation of the indication by the WHF detection algorithm according to the determined HF risk score.

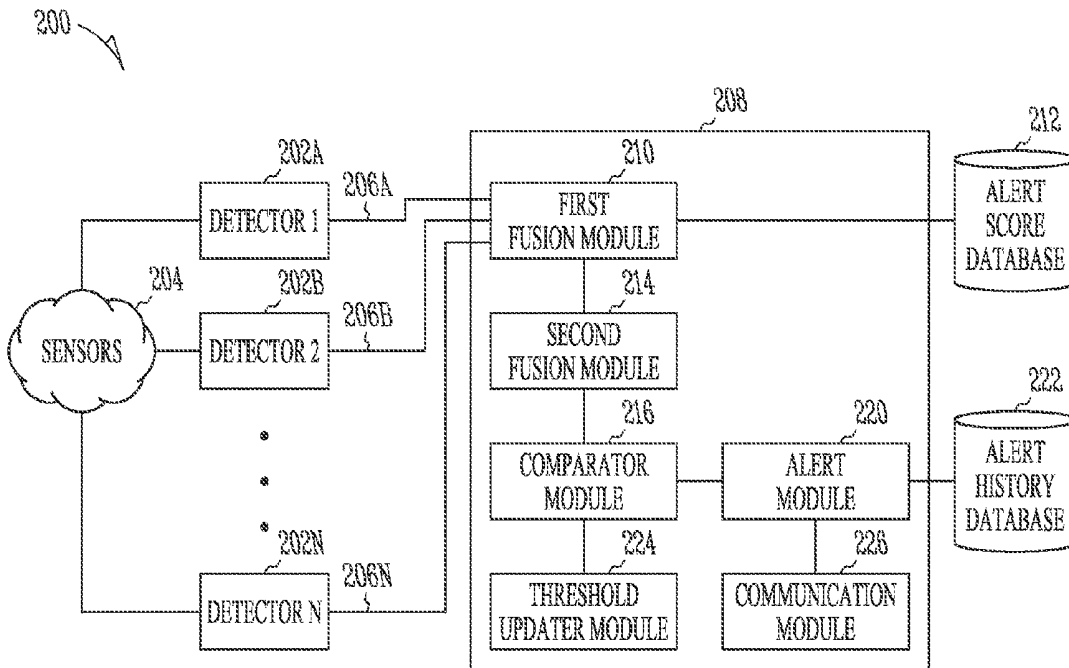

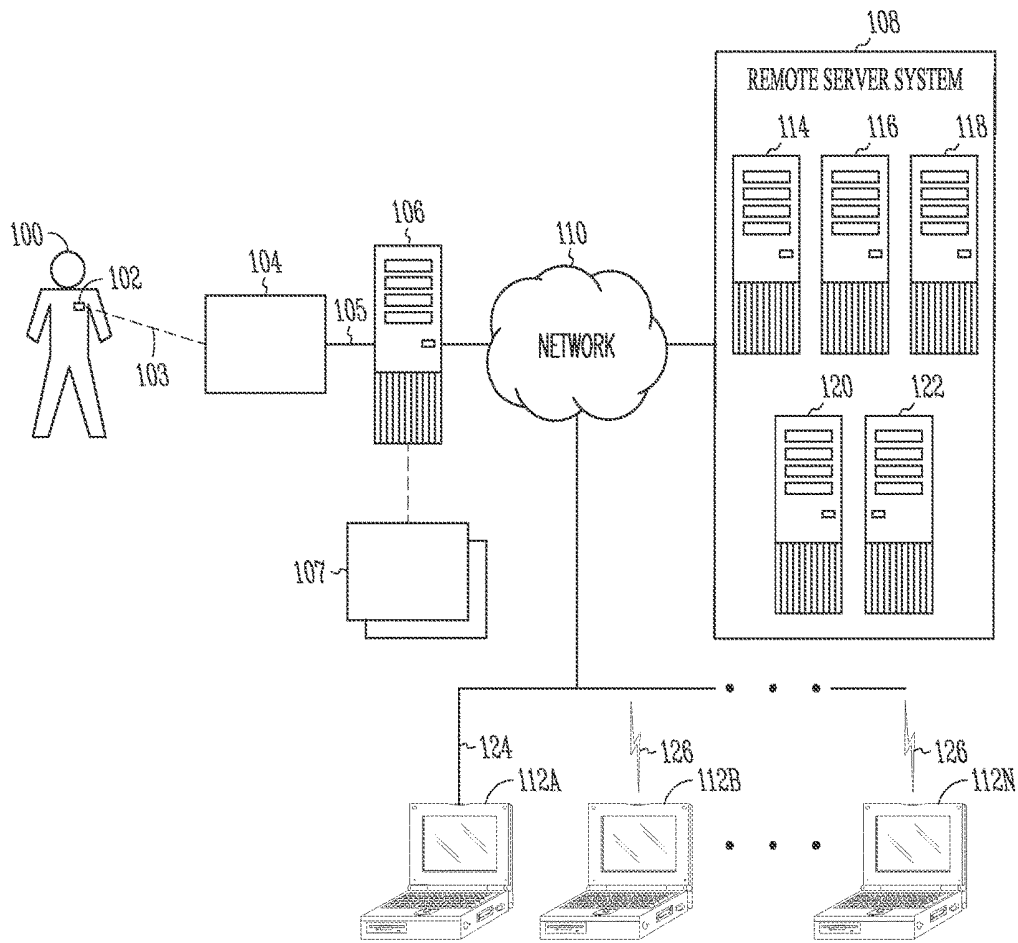

FIG. 1

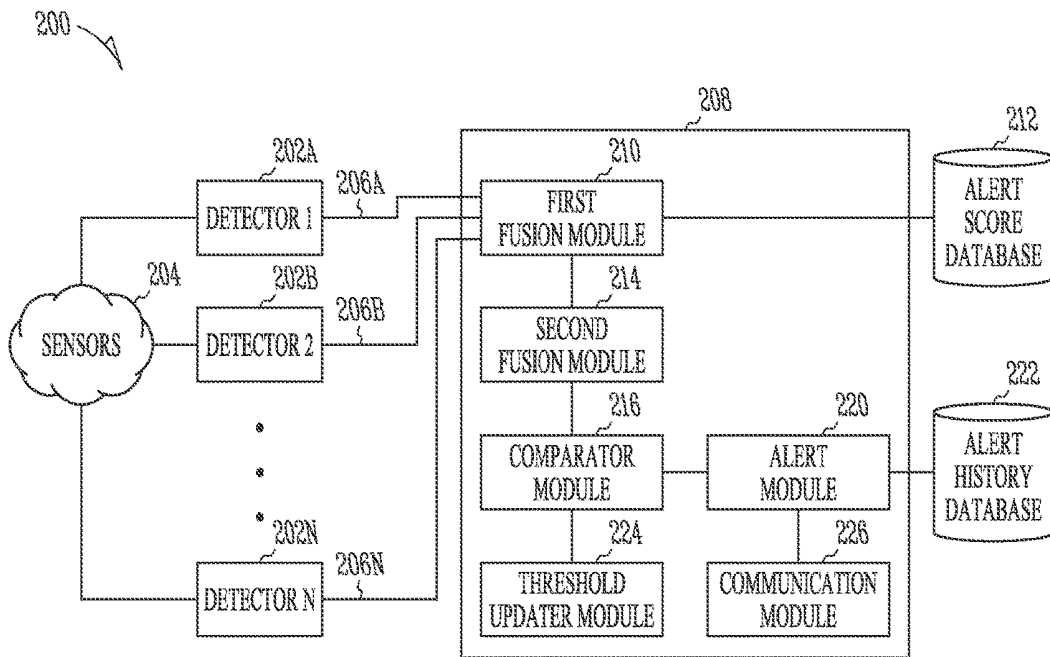

FIG. 2

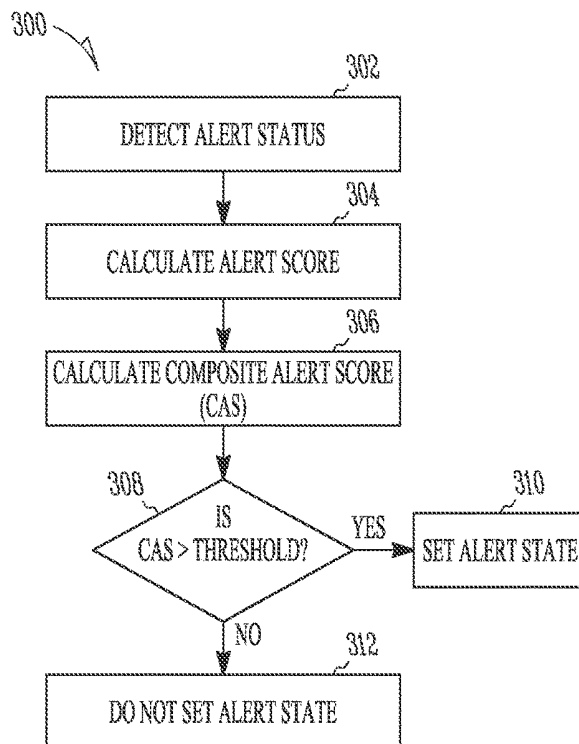

FIG. 3

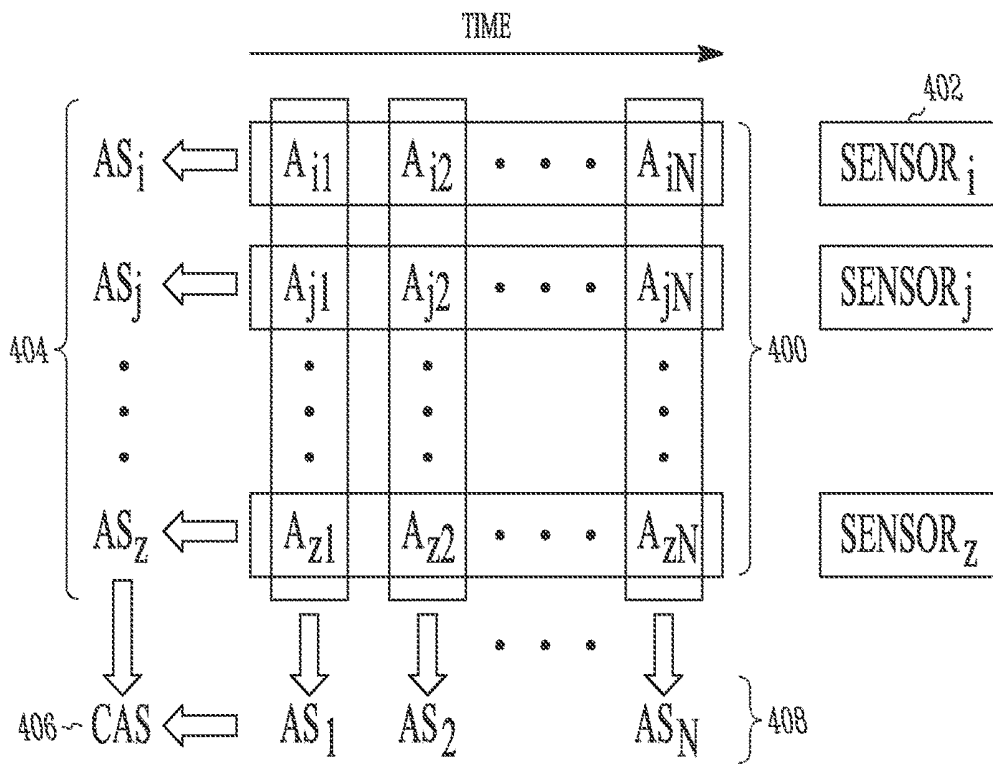

FIG. 4

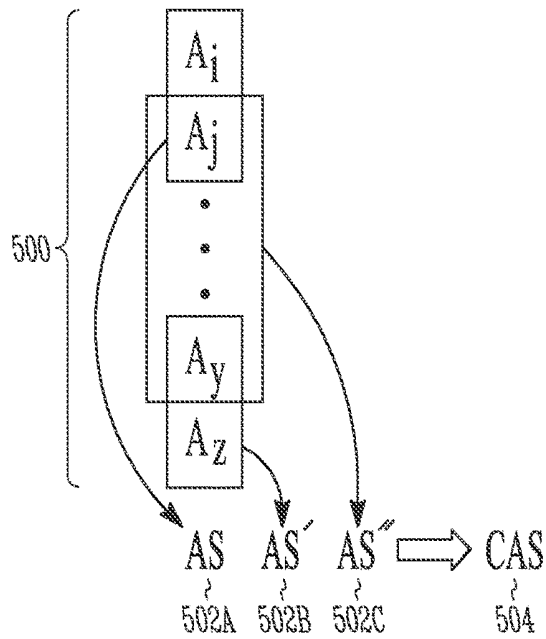

FIG. 5

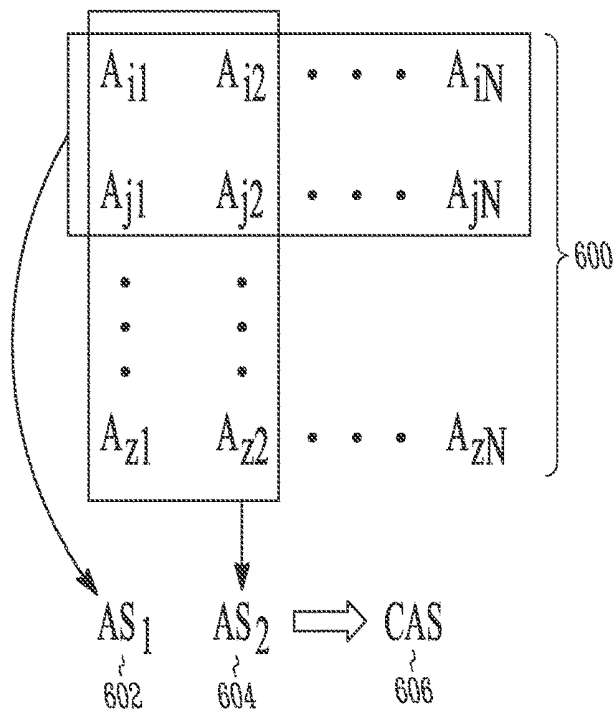

FIG. 6

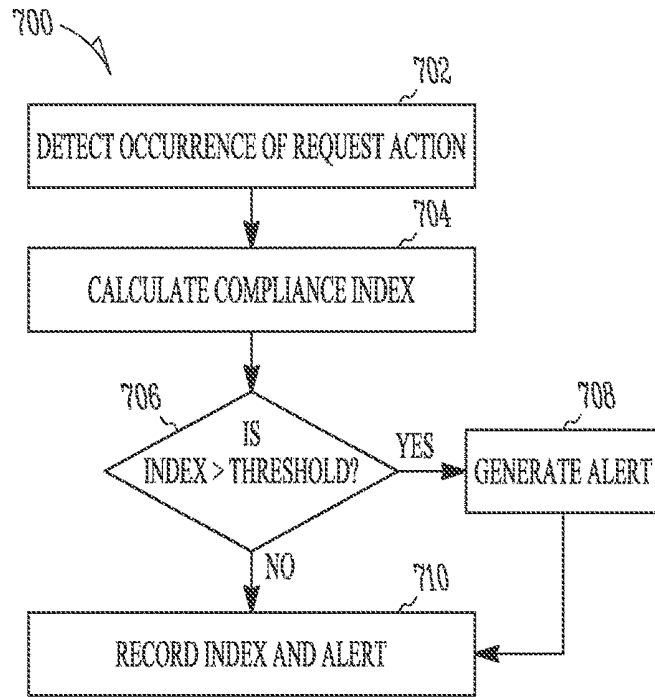

FIG. 7

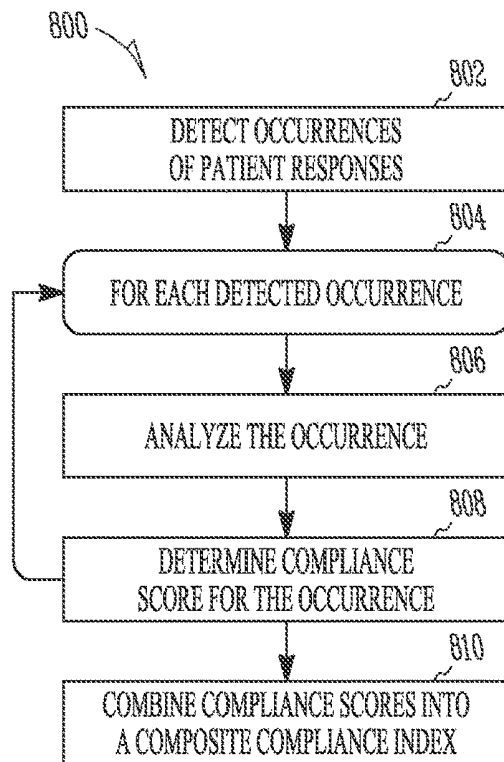
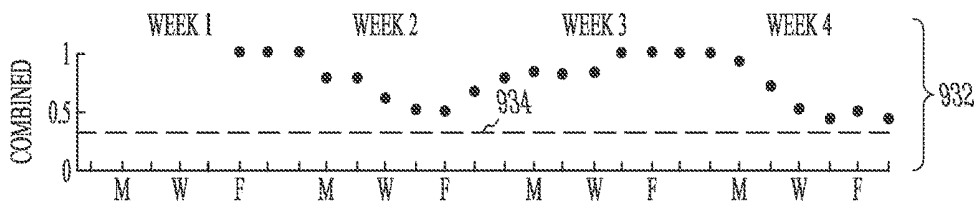
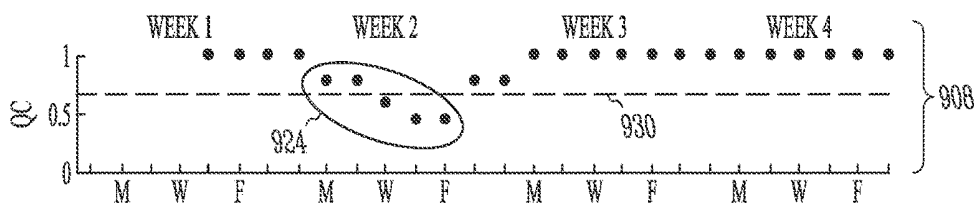
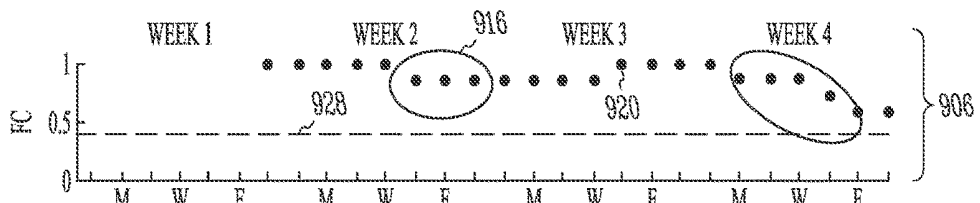
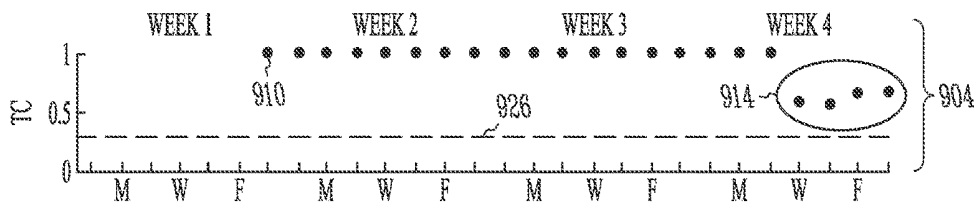
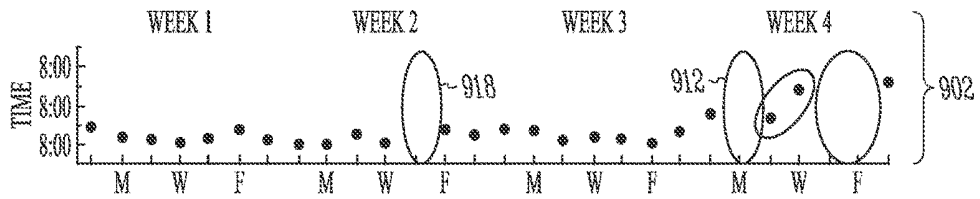
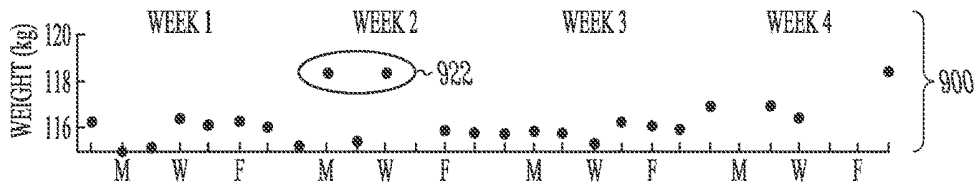

FIG. 8



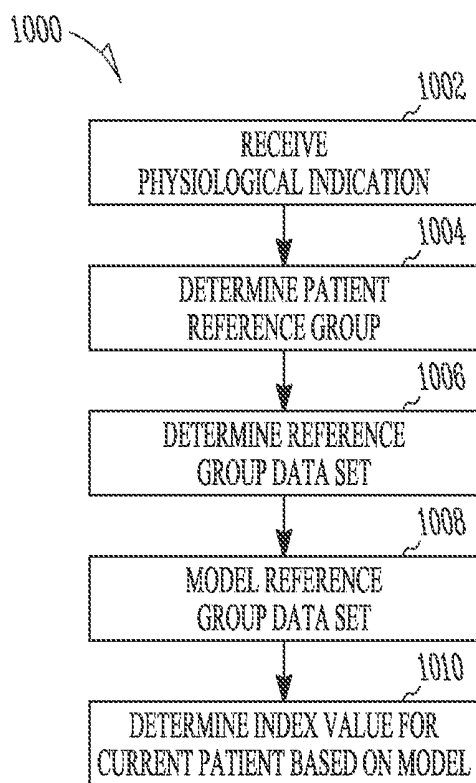

FIG. 10

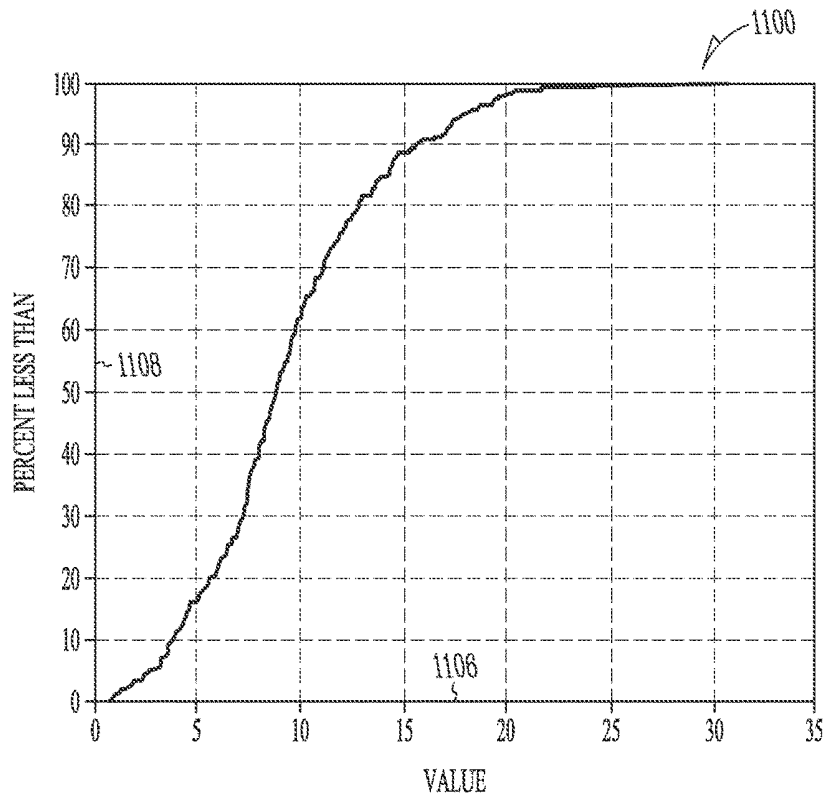

FIG. 11A

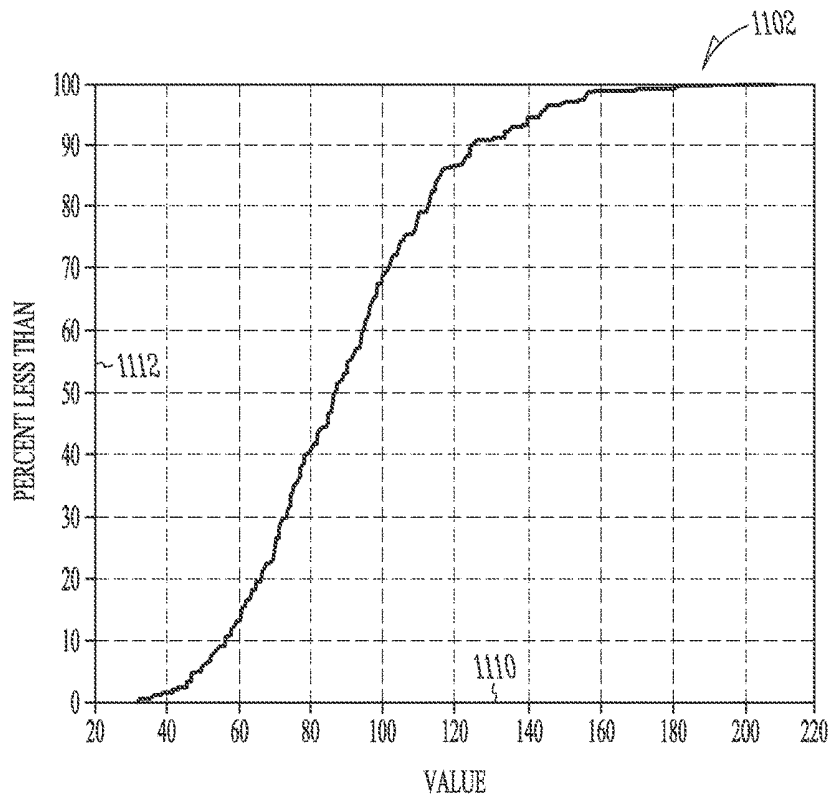

FIG. 11B

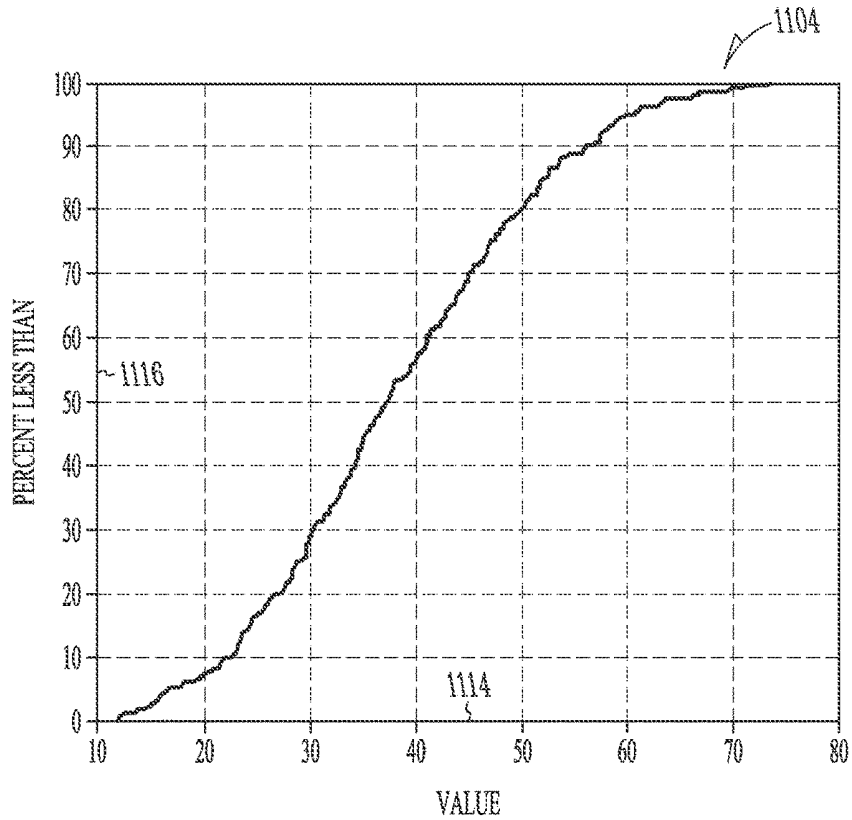

FIG. 11C

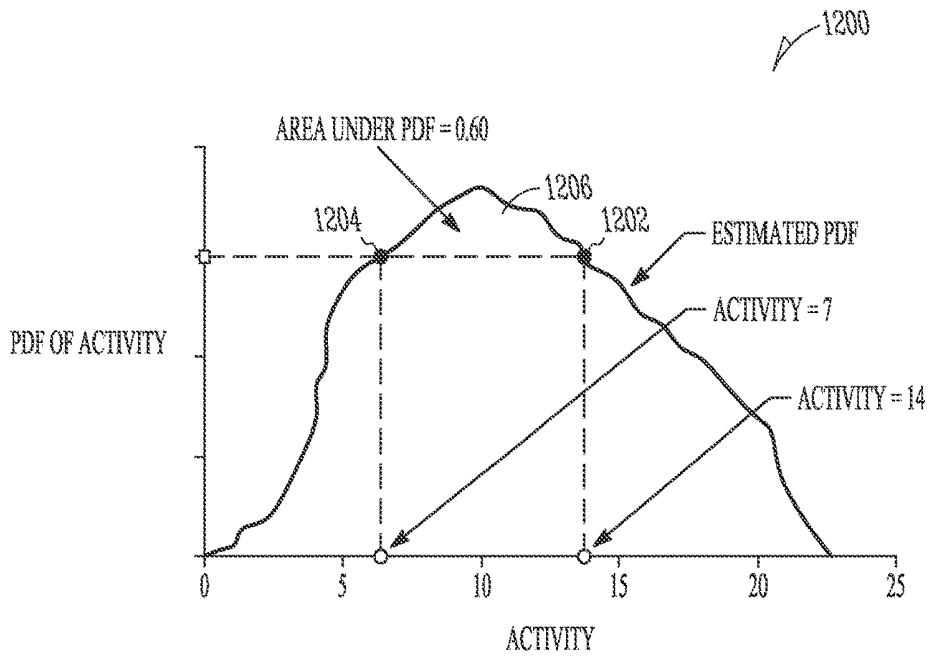

FIG. 12

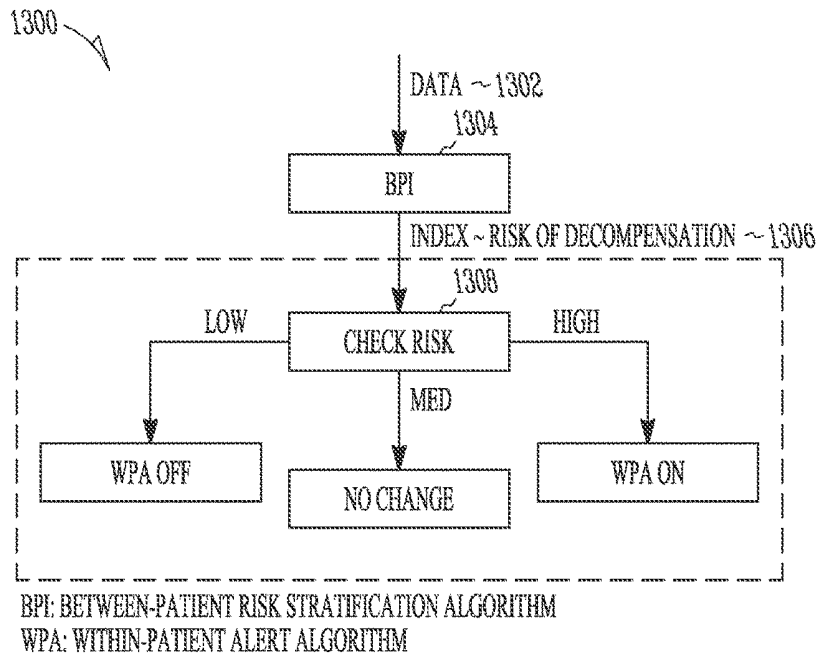

FIG. 13

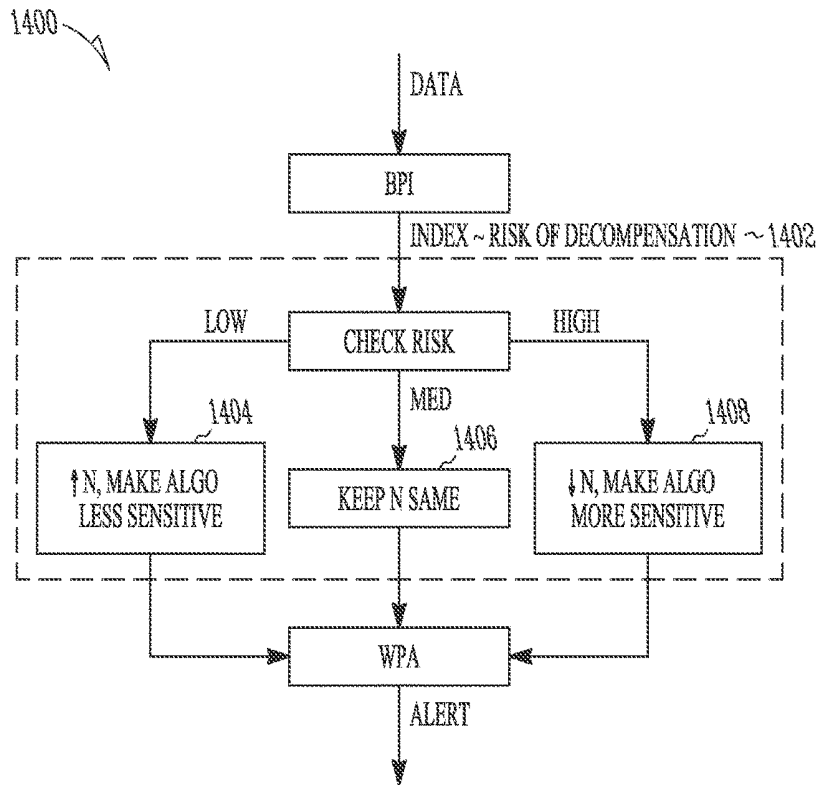

FIG. 14

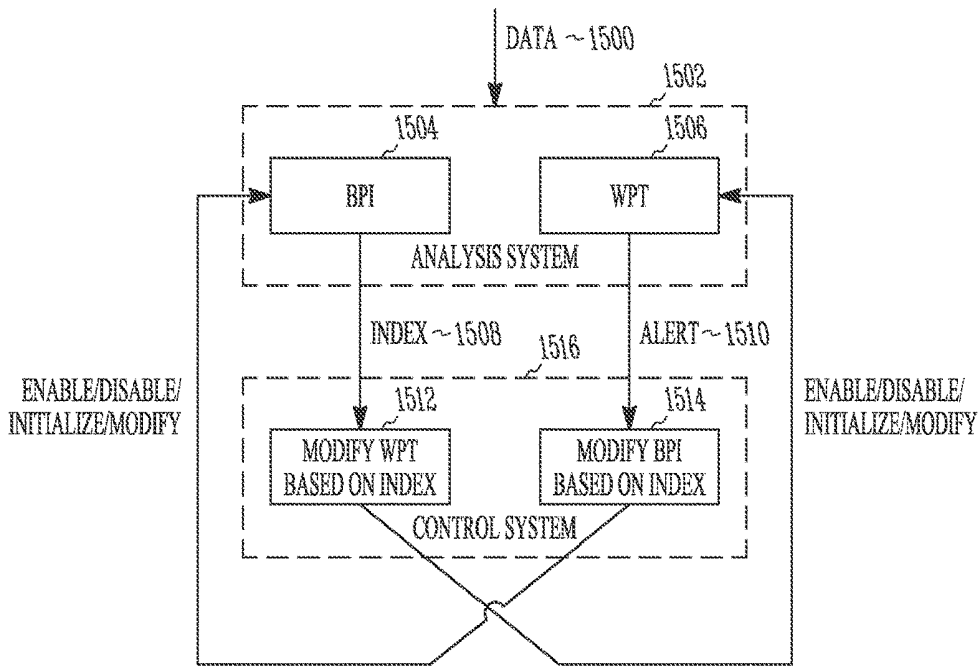

FIG. 15

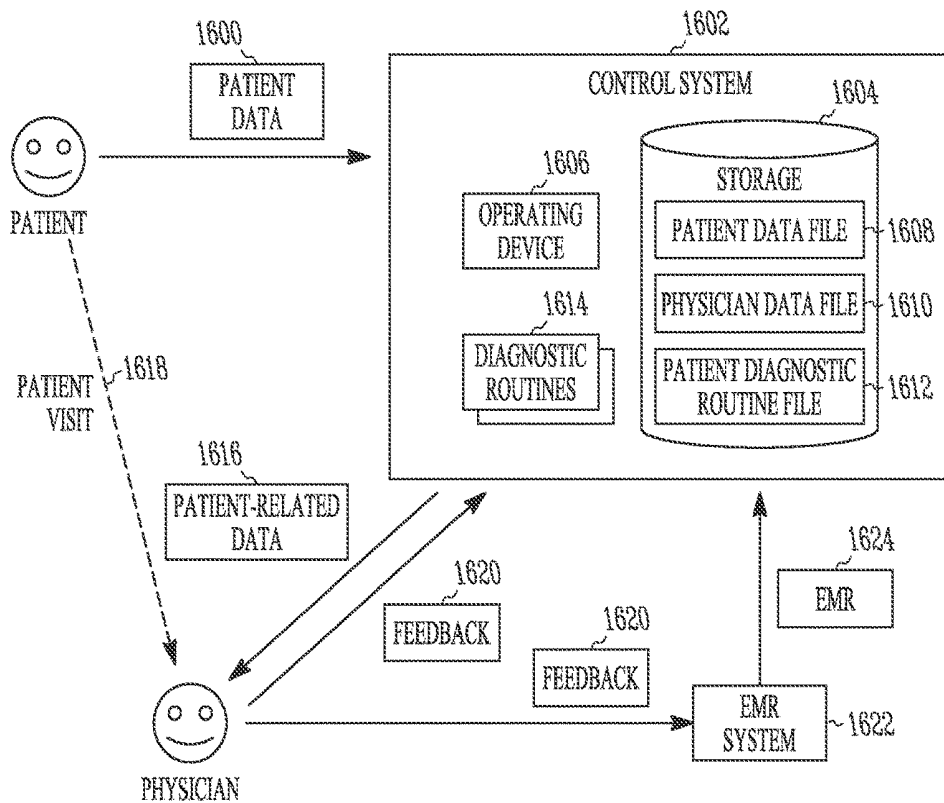

FIG. 16

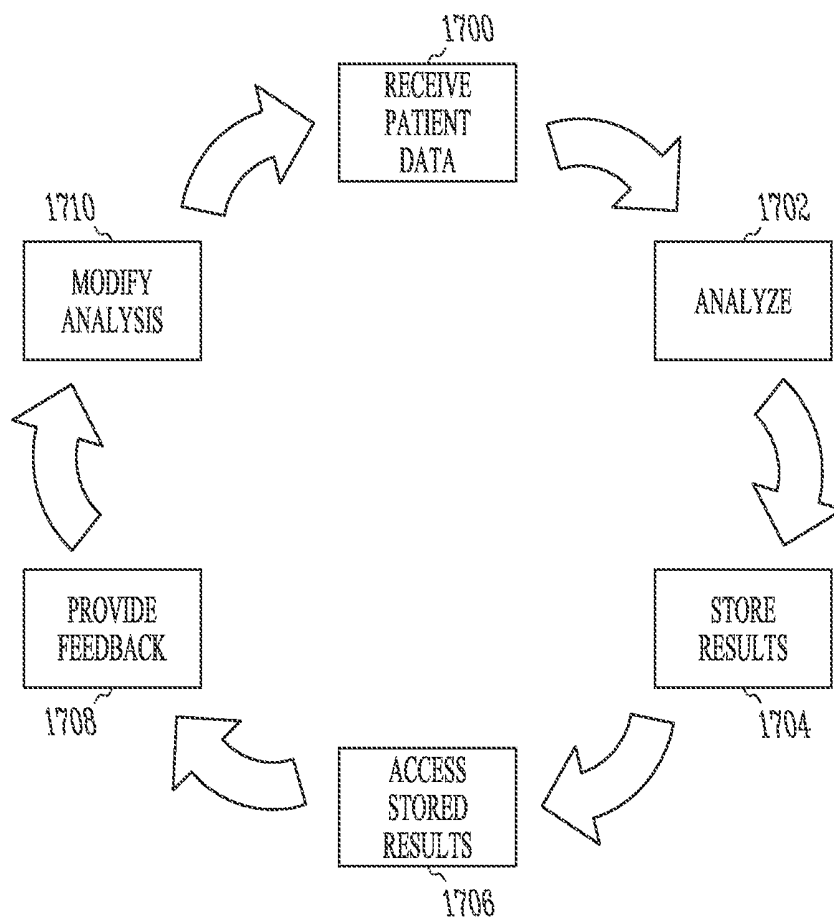

FIG. 17

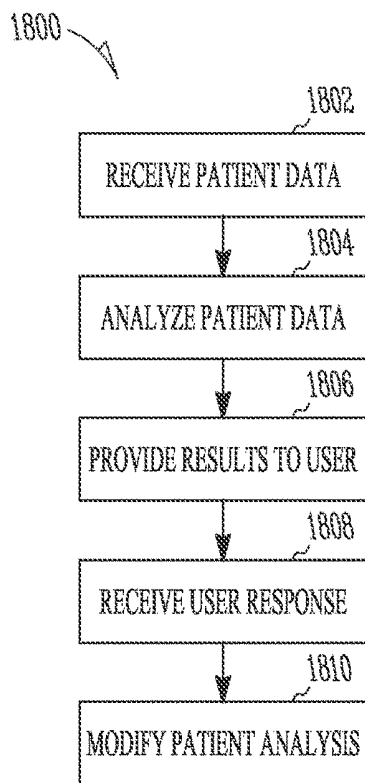

FIG. 18

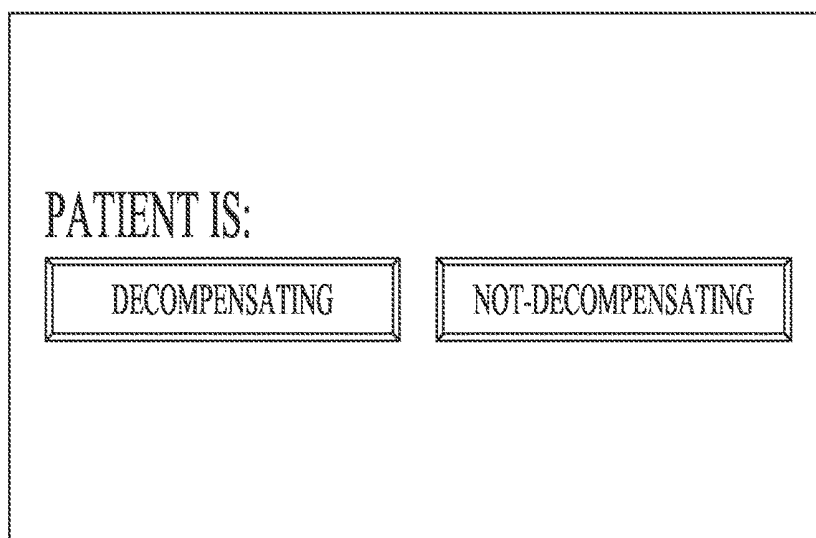

FIG. 19

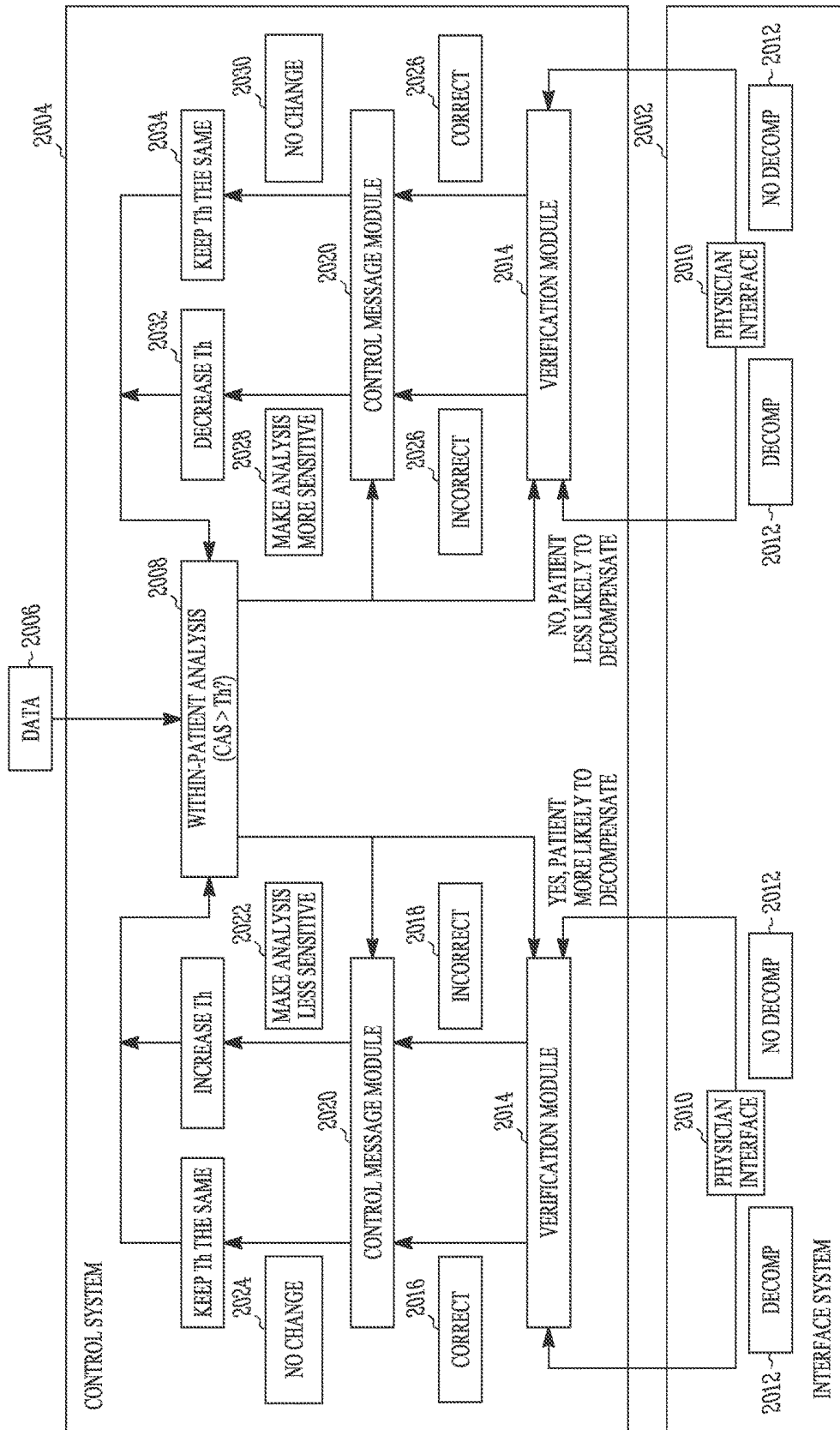

FIG. 20

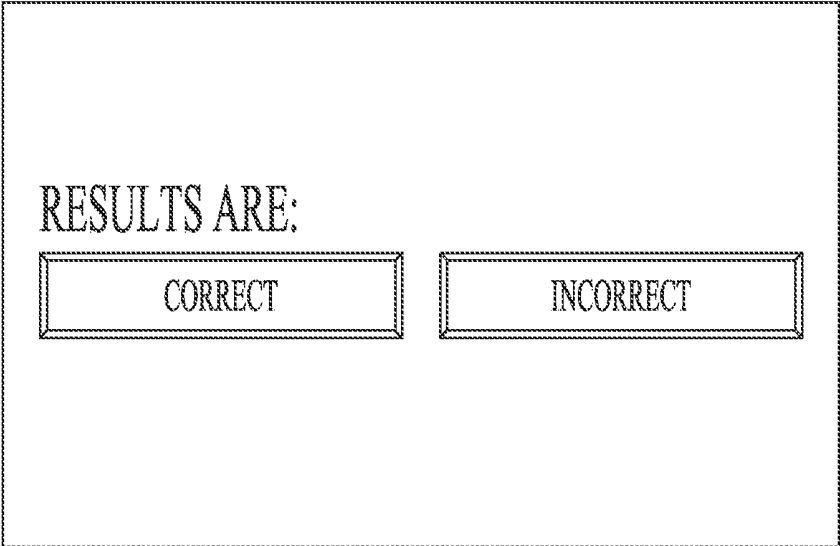

FIG. 21

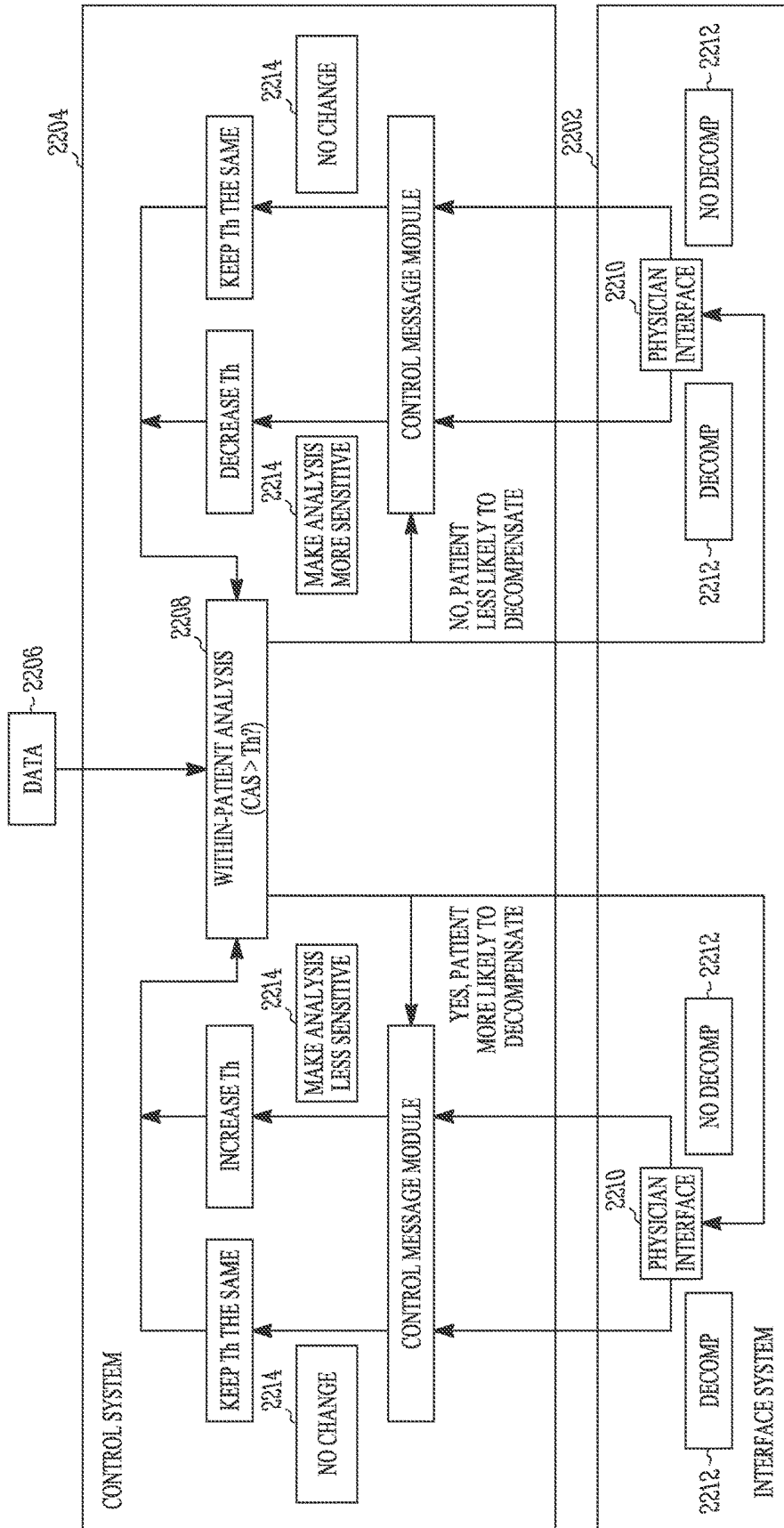

FIG. 22

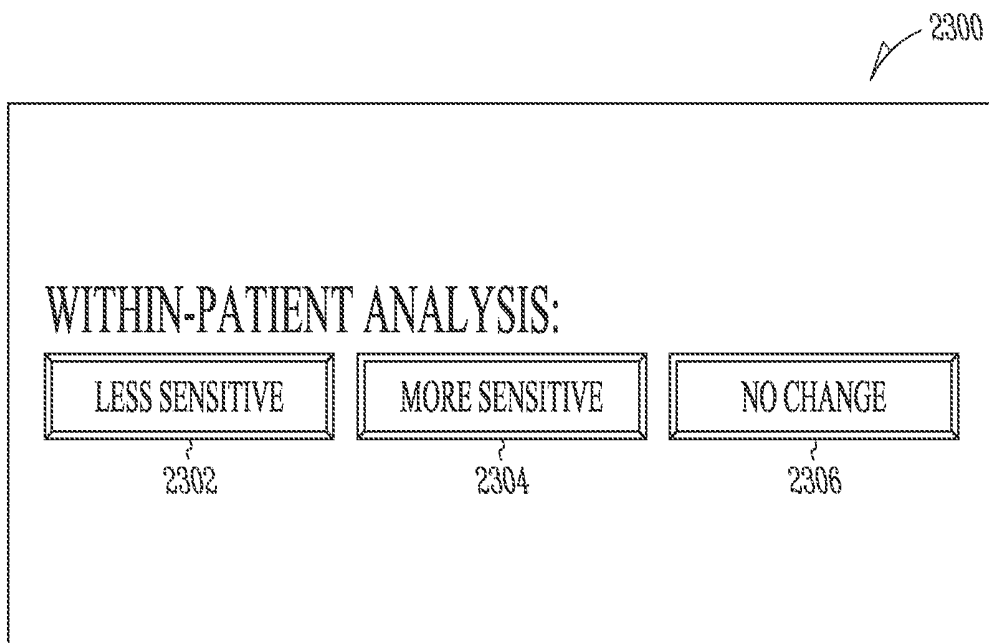

FIG. 23

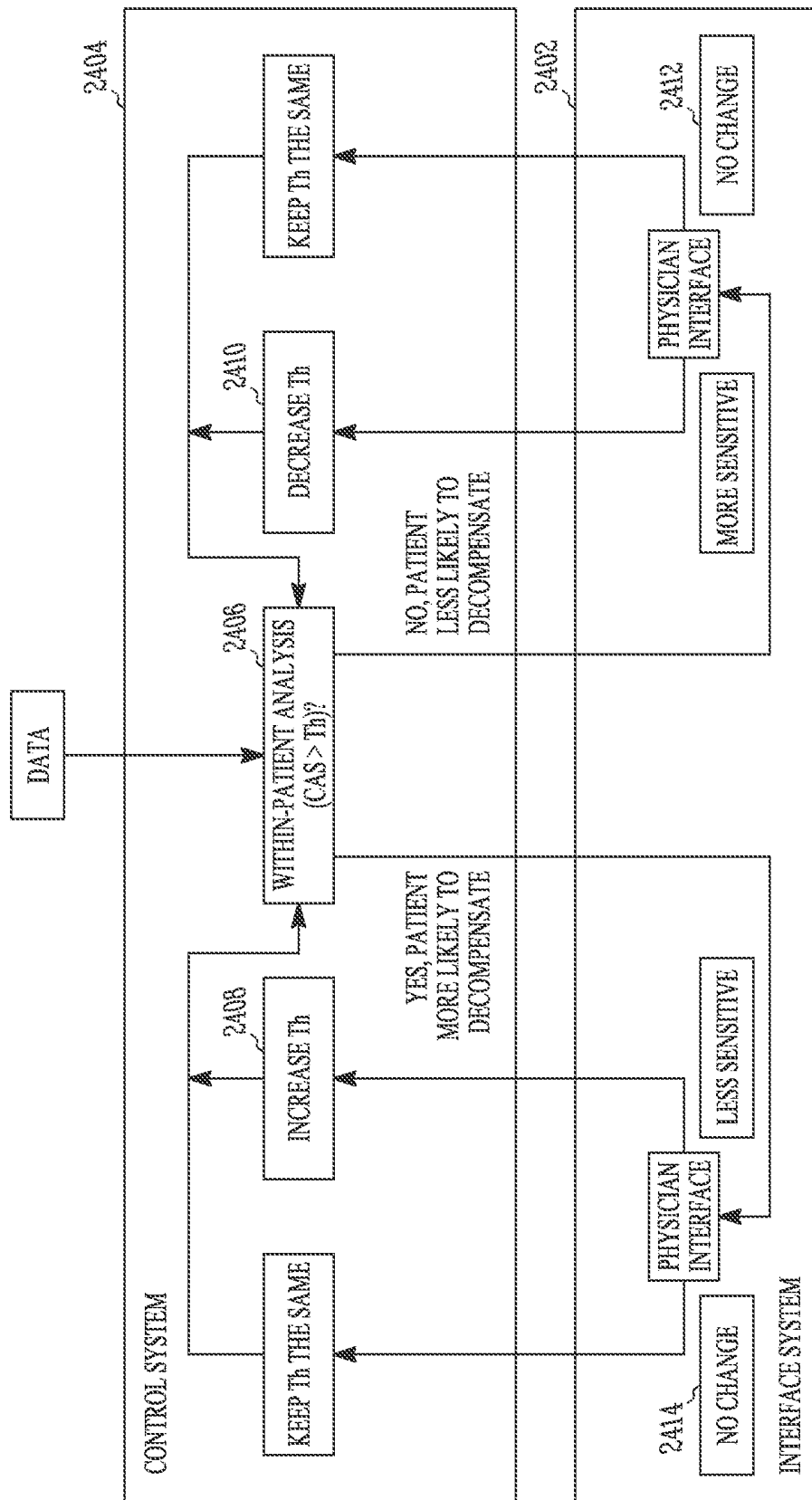

FIG. 24

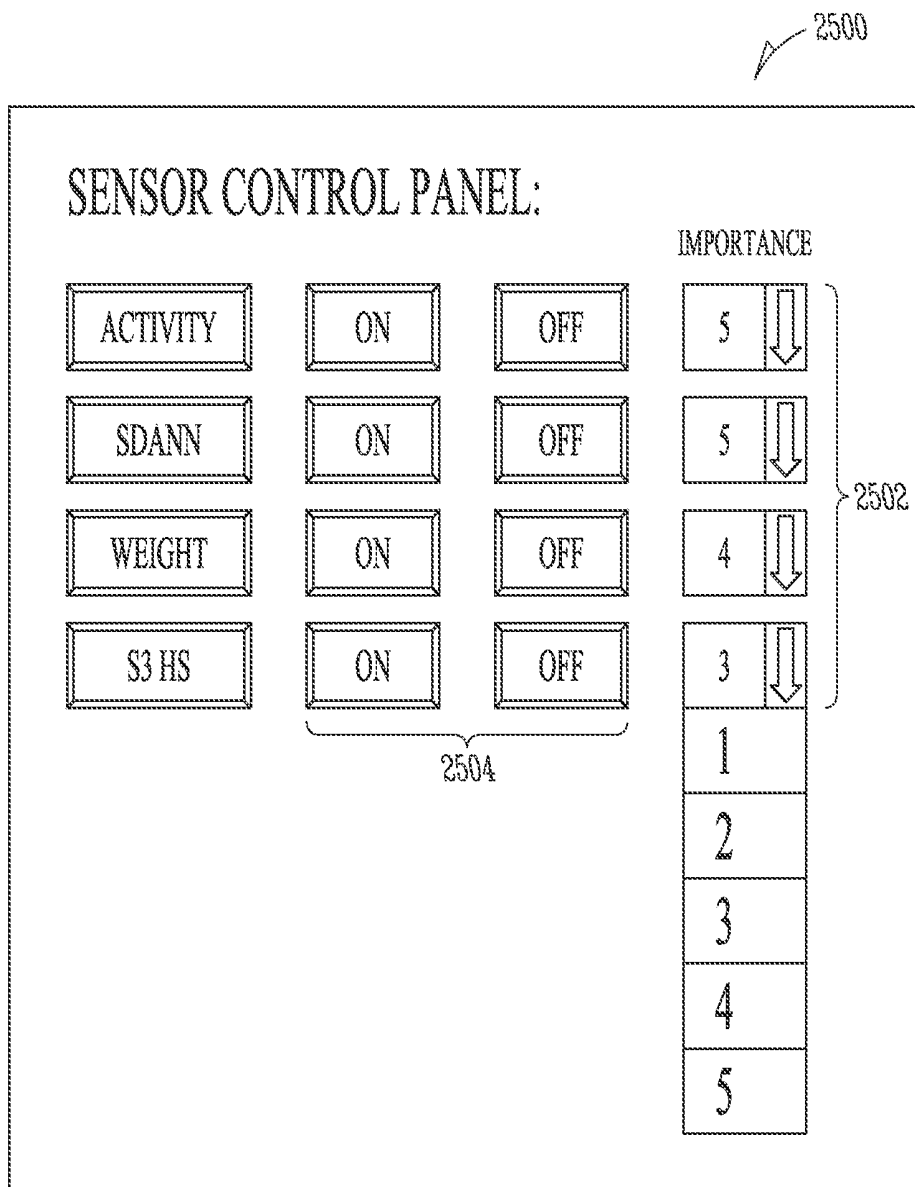

FIG. 25

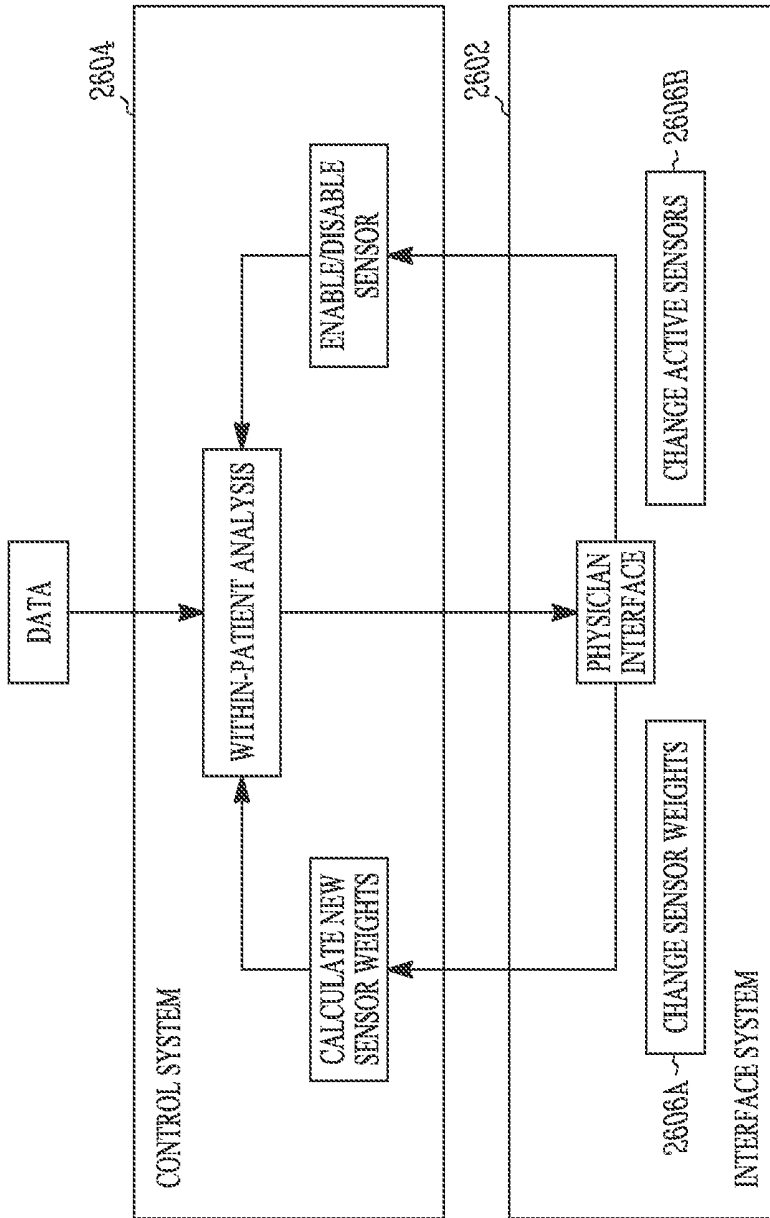

FIG. 26

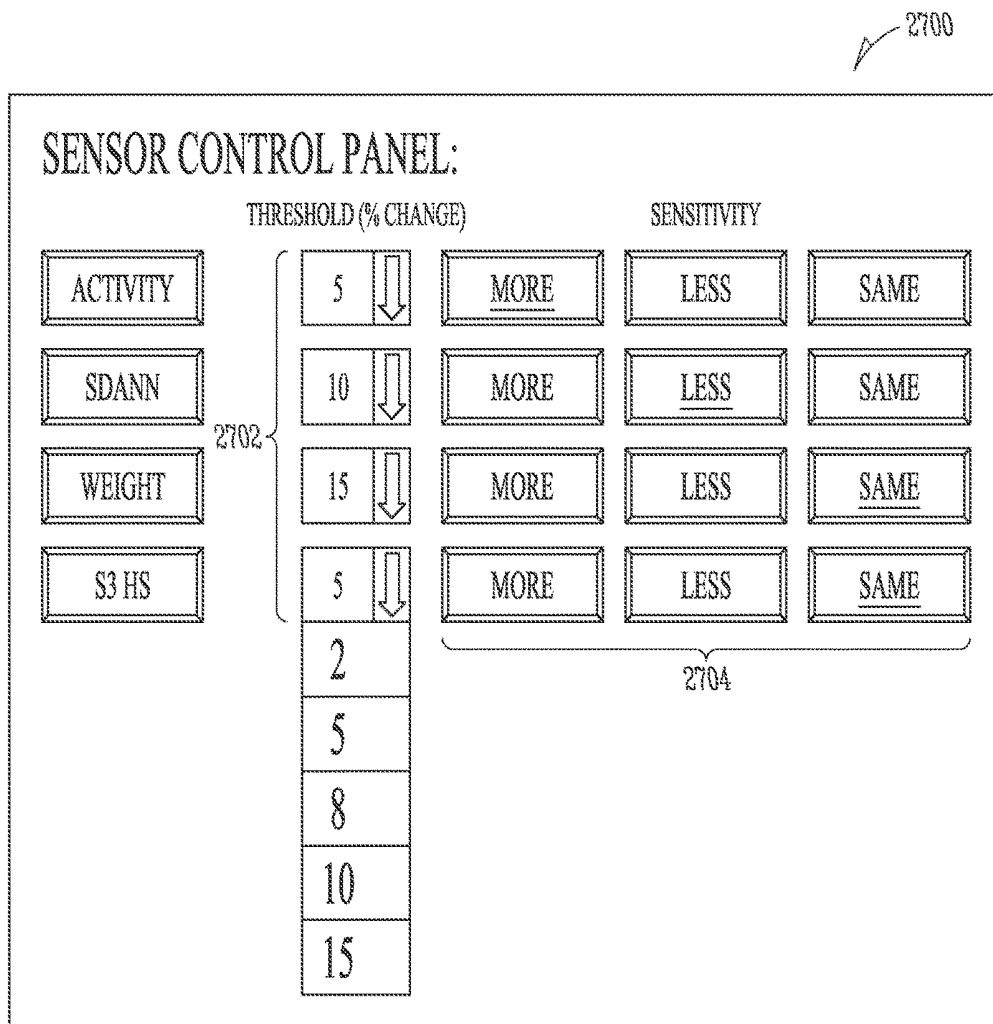

FIG. 27

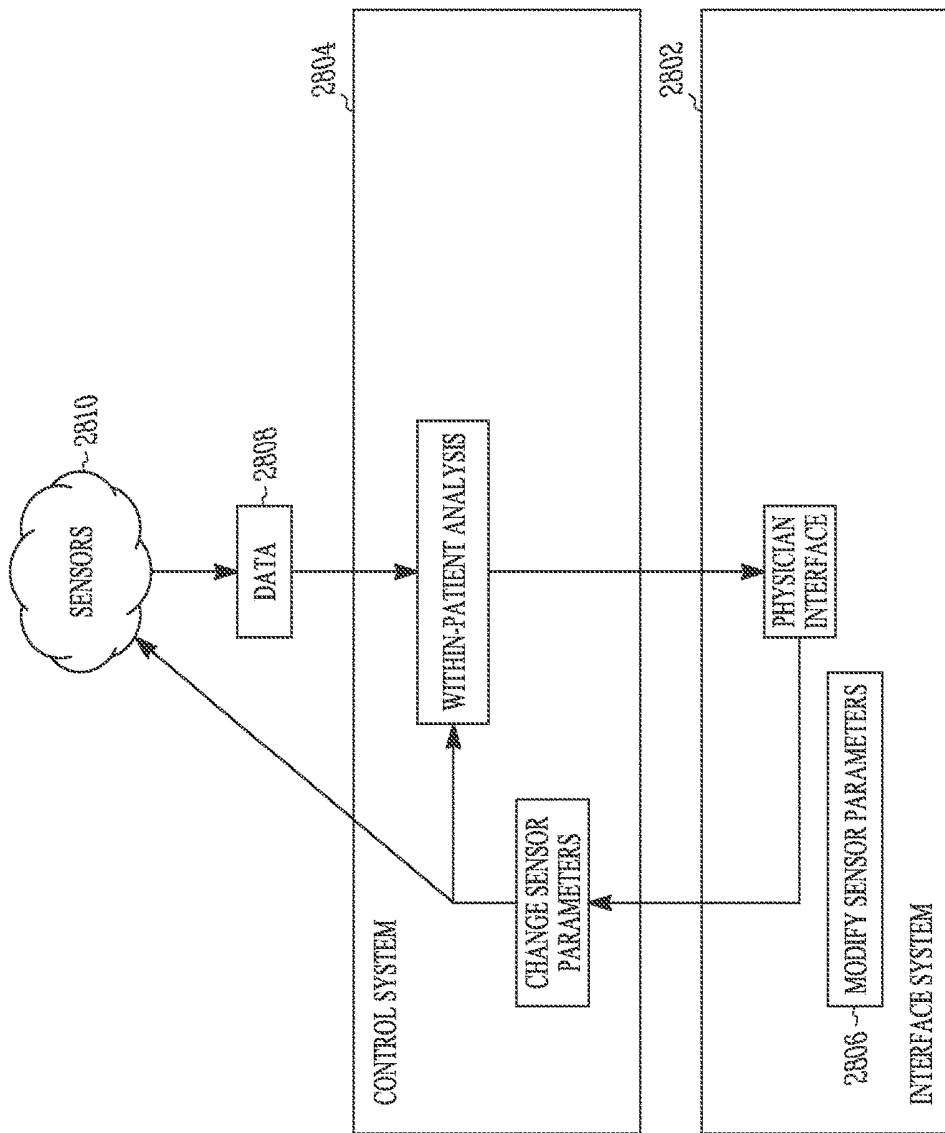

FIG. 28

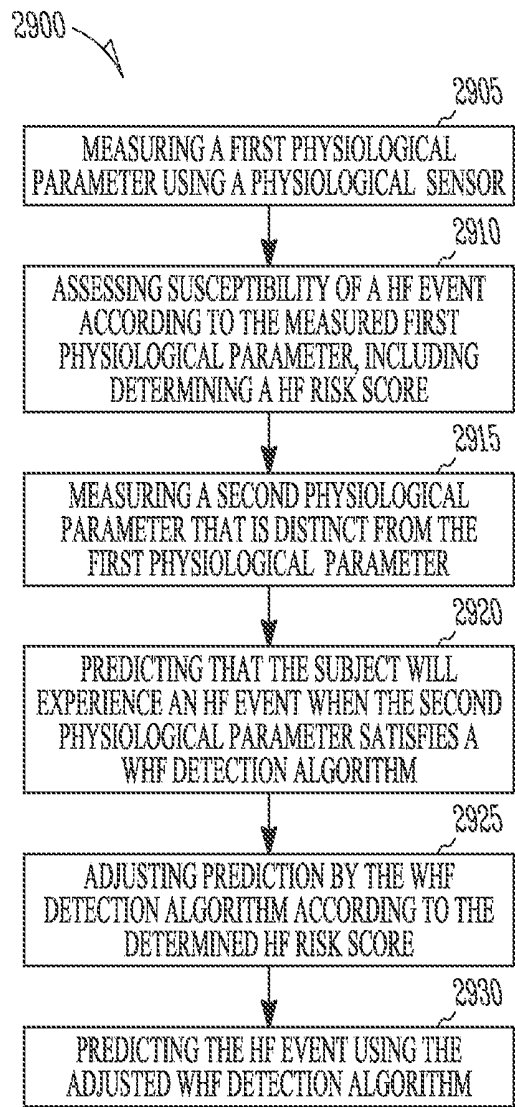

FIG. 29

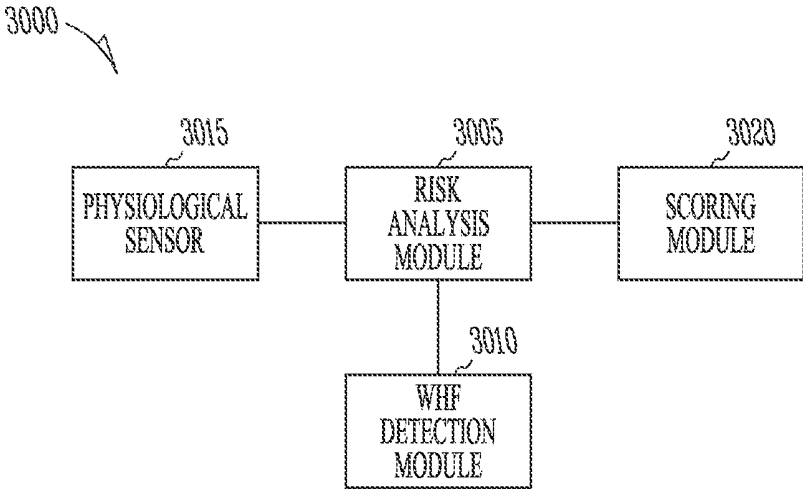

FIG. 30

**RISK STRATIFICATION BASED HEART
FAILURE DETECTION ALGORITHM**

PRIORITY CLAIM

[0001] This application is a continuation of U.S. application Ser. No. 13/726,786, filed Dec. 26, 2012, which is a continuation-in-part of U.S. patent application Ser. No. 11/616,430, filed on Dec. 27, 2006, now issued as U.S. Pat. No. 8,768,718, which is incorporated herein by reference in its entirety.

COPYRIGHT NOTICE

[0002] A portion of the disclosure of this patent document contains material that is subject to copyright protection. The copyright owner has no objection to the facsimile reproduction by anyone of the patent document or the patent disclosure, as it appears in the Patent and Trademark Office patent files or records, but otherwise reserves all copyright rights whatsoever. The following notice applies to the software and data as described below and in the drawings that form a part of this document: Copyright 2006, Cardiac Pacemakers, Inc. All Rights Reserved.

TECHNICAL FIELD

[0003] This patent document pertains generally to implantable medical devices, and more particularly, but not by way of limitation, to systems and methods for between-patient comparisons for risk stratification of future heart failure decompensation.

BACKGROUND

[0004] Ambulatory medical devices include implantable medical devices (IMDs) and wearable medical devices. IMDs include cardiac rhythm management devices such as pacemakers and implantable cardioverter/defibrillators. Wearable medical devices include wearable cardioverter defibrillators (WCDs) and wearable diagnostic devices (e.g., an ambulatory monitoring vest).

[0005] IMDs typically have the capability to communicate with an external device, such as an external programmer, via wireless telemetry, such as a radio-frequency (RF) or other telemetry link. While an external programmer is typically provided to program and modify the operating parameters of an IMD, IMDs can also include the capability for bidirectional communication so that information, such as physiological data, can be transmitted to the programmer. Wearable devices can also communicate data with a separate device. Home health care remote monitoring systems can also communicate with the medical devices and collect the patient and patient-related data. In addition, some monitoring systems can also collect other objective or subjective data using additional external sensors, such as a blood pressure cuff, a weight scale, or a specialized device that prompts the patient with questions regarding their health state. Some home health care monitoring systems can communicate with a centralized or other remote system, such as directly or using a networked system. Centralized systems, including medical practice systems, provide an efficient mode for physicians and other medical practitioners to manage patient-related data.

OVERVIEW

[0006] This document relates generally to systems, devices, and methods that provide one or both of diagnostic monitoring and electrical device-based therapy to the heart of a patient or subject. In particular it relates to, systems, devices, and methods that predict the likelihood that a subject will experience a physiological event, such as a heart failure (HF) related event.

[0007] A system example includes a risk analysis module and a worsening heart failure (WHF) detection module. The risk analysis module measures at least one first physiological parameter of a subject using a physiological sensor of an ambulatory medical device, and determines a HF risk score for the subject according to the at least one measured first physiological parameter. The HF risk score indicates susceptibility of the subject to experiencing a HF event. The WHF detection module measures at least one second physiological parameter of the subject using the same or different physiological sensor of the ambulatory medical device, and generates an indication of prediction that the subject will experience an HF event when the at least one second physiological parameter satisfies a WHF detection algorithm. The risk analysis module adjusts generation of the indication by the WHF detection algorithm according to the determined HF risk score.

[0008] This overview is intended to provide an overview of the subject matter of the present patent application. It is not intended to provide an exclusive or exhaustive explanation of the invention. The detailed description is included to provide further information about the subject matter of the present patent application.

BRIEF DESCRIPTION OF THE DRAWINGS

[0009] In the drawings, which are not necessarily drawn to scale, like numerals describe substantially similar components throughout the several views. Like numerals having different letter suffixes represent different instances of substantially similar components. The drawings illustrate generally, by way of example, but not by way of limitation, various embodiments discussed in the present document.

[0010] FIG. 1 illustrates portions of a system that enables physician-patient communication.

[0011] FIG. 2 is a detailed schematic view illustrating portions of a system that measures and detects variance in patient-related data to identify acute changes that may indicate an onset of a physiological condition.

[0012] FIG. 3 illustrates a method of using a composite alert score to detect an increased likelihood of a disease state or onset of a physiological condition.

[0013] FIGS. 4-6 are diagrams illustrating examples of relationships between alert values, alert scores, and composite alert scores.

[0014] FIG. 7 illustrates an example of a method of using sensed patient actions to determine a level of patient compliance.

[0015] FIG. 8 illustrates an example of a method of determining a compliance index over two or more different patient responses.

[0016] FIGS. 9A-9F are charts illustrating examples of recorded patient actions in response to at least one specific request.

[0017] FIG. 10 illustrates an example of a method of deriving a probabilistic index based on a particular patient compared to a patient population.

[0018] FIGS. 11A-C illustrate examples of a physical activity cumulative distribution function (CDF) chart, an SDANN CDF chart, and a Footprint % CDF chart.

[0019] FIG. 12 is an example of a probability distribution function chart that illustrates reference group patients' physical activity levels.

[0020] FIGS. 13 and 14 are diagrams illustrating examples of control and data flow between patient analysis processes.

[0021] FIG. 15 illustrates a cross-feedback configuration of patient analysis processes.

[0022] FIG. 16 is a dataflow diagram illustrating an example of a physician feedback process.

[0023] FIG. 17 illustrates an example of a feedback loop between a central system and a physician.

[0024] FIG. 18 is a flowchart illustrating an example of a method of using physician feedback to modify the execution of patient analysis routines.

[0025] FIG. 19 is an example of a user-interface to allow a medical professional to submit input or feedback to a control system.

[0026] FIG. 20 is a control flow diagram illustrating an example of an interaction between a user-interface system and a control system in accordance with the user-interface illustrated in FIG. 19.

[0027] FIG. 21 is an example of a user-interface to allow a medical professional to submit input or feedback to a control system.

[0028] FIG. 22 is a control flow diagram illustrating an example of an interaction between a user-interface system and a control system in accordance with the user-interface illustrated in FIG. 21.

[0029] FIG. 23 is another example of a user-interface to allow a medical professional to submit feedback to a control system.

[0030] FIG. 24 is a control flow diagram illustrating an example of an interaction between a user-interface system and a control system in accordance with the user-interface illustrated in FIG. 23.

[0031] FIG. 25 is another example of a user-interface.

[0032] FIG. 26 is a control flow diagram illustrating an example of an interaction between a user-interface system and a control system in accordance with the user-interface illustrated in FIG. 25.

[0033] FIG. 27 is another example of a user-interface to control one or more sensors.

[0034] FIG. 28 is a control flow diagram illustrating an example of an interaction between a user-interface system and a control system in accordance with the user-interface illustrated in FIG. 27.

[0035] FIG. 29 is a flow diagram of an example of a method of operating a medical device to detect the onset of a physiological event.

[0036] FIG. 30 is a block diagram showing portions of a system 3000 that detects the onset of a physiological event such as an event related to heart failure.

DETAILED DESCRIPTION

[0037] An ambulatory medical device is capable of moving about with the subject, such as chronically during activities of daily living. Such a device may include one or more of the features, structures, methods, or combinations

thereof described herein. For example, a cardiac monitor or a cardiac stimulator may be implemented to include one or more of the advantageous features or processes described below. It is intended that such a monitor, stimulator, or other implantable or partially implantable device need not include all of the features described herein, but may be implemented to include selected features that provide for unique structures or functionality. Such a device may be implemented to provide a variety of therapeutic or diagnostic functions.

Exemplary System Overview

[0038] FIG. 1 illustrates portions of a system that enables physician-patient communication. In the example of FIG. 1, a patient 100 is provided with an implantable medical device (IMD) 102. Examples of implantable medical devices include a pacemaker, an implantable cardioverter defibrillator (ICD), a cardiac resynchronization therapy pacemaker (CRT-P), a cardiac resynchronization therapy defibrillator (CRT-D), a neurostimulation device, a deep brain stimulation device, a cochlear implant or a retinal implant. In some examples, the IMD 102 is capable of sensing physiological data and storing such data for later communication. Examples of physiological data include implantable electrograms, surface electrocardiograms, heart rate intervals (e.g., AA, VV, AV or VA intervals), electrogram templates such as for tachyarrhythmia discrimination, pressure (e.g., intracardiac or systemic pressure), oxygen saturation, activity, heart rate variability, heart sounds, impedance, respiration, intrinsic depolarization amplitude, or the like.

[0039] The IMD 102 is capable of bidirectional communication 103 with an external transceiver 104. In various examples, the IMD 102 receives commands from the transceiver 104 and may also communicate one or more patient indications to the transceiver 104. Examples of patient indications may include such things as heart rate, heart rate variability, data related to tachyarrhythmia episodes, hemodynamic stability, activity, therapy history, autonomic balance motor trends, electrogram templates for tachy discrimination, heart rate variability trends or templates, or trends, templates, or abstractions derived from sensed physiological data. In some examples, patient indications include one or more physiological indications, such as the physiological data described above. In another example, the IMD 102 may also communicate one or more device indications to the transceiver 104. Examples of device indications include lead/shock impedance, pacing amplitudes, pacing thresholds, or other device metrics. In certain examples, the IMD 102 may communicate sensed physiological signal data to the transceiver 104, which may then communicate the signal data to a remote device, such as for processing.

[0040] Typically, the transceiver 104 is located in close proximity to the patient 100. The transceiver 104 may be included within or attached to a personal computer or a specialized device, such as a medical device programmer. In one example, the transceiver 104 is a hand-held device that is capable of connecting to a local computer 106. Typically, a connection 105 can be made using a hard-wired connection (e.g., serial, USB, Firewire) or a wireless connection (e.g., RF, IR). In some examples, the local computer 106 is a specialized device or a personal computer. In certain examples, the local computer 106 is adapted to communicate with a remote server system 108. The communication link between the local computer 106 and the remote server system 108 is typically made through a computer or tele-

communications network **110**. The network **110** may include, in various examples, one or more wired or wireless networking such as the Internet, satellite telemetry, cellular telemetry, microwave telemetry, or other long-range communication networks.

[0041] In an example, one or more external sensors **107** are adapted to communicate with the transceiver **104** and may transmit and receive information, such as sensed data. External sensors **107** may be used to measure patient physiological data, such as temperature (e.g., a thermometer), blood pressure (e.g., a sphygmomanometer), blood characteristics (e.g., glucose level), body weight, physical strength, mental acuity, diet, or heart characteristics. An external sensor **107** may also include one or more environmental sensors. The external sensors **107** can be placed in a variety of geographic locations (in close proximity to patient or distributed throughout a population) and can record non-patient specific characteristics such as, for example, temperature, air quality, humidity, carbon monoxide level, oxygen level, barometric pressure, light intensity, and sound.

[0042] External sensors **107** can also include devices that measure subjective data from the patient. Subjective data includes information related to a patient's feelings, perceptions, and/or opinions, as opposed to objective physiological data. For example, the "subjective" devices can measure patient responses to inquiries such as "How do you feel?", "How is your pain?" and "Does this taste good?" Such a device may also be adapted to present interrogatory questions related to observational data, such as "What color is the sky?" or "Is it sunny outside?" The device can prompt the patient and record responsive data from the patient using visual and/or audible cues. For example, the patient can press coded response buttons or type an appropriate response on a keypad. Alternatively, responsive data may be collected by allowing the patient to speak into a microphone and using speech recognition software to process the response.

[0043] In some examples, the remote server system **108** comprises one or more computers, such as a database server **114**, a network server **116**, a file server **118**, an application server **120** and a web server **122**. In certain examples, one or more terminals **112A**, **112B**, . . . , **112N** are locally or remotely connected to the remote server system **108** via network **110**. The terminals **112** are communicatively coupled to the remote server system **108** using a wired **124** or a wireless connection **126**. Examples of terminals **112** may include personal computers, dedicated terminal consoles, handheld devices (e.g., a personal digital assistant (PDA) or cellular telephone), or other specialized devices. In various examples, one or more users may use a terminal **112** to access the remote server system **108**. For example, a customer service professional may use a terminal **112** to access records stored in the remote server system **108** to update patient records. As another example, a physician or clinician may use a terminal **112** to receive or provide patient-related data, such as comments regarding a patient visit, physiological data from a test or collected by a sensor or monitor, therapy history (e.g., IMD shock or pacing therapy), or other physician observations.

[0044] In some examples, the IMD **102** is adapted to store patient data and to use the data to provide tailored therapy. For example, using historical physiological data, an IMD **102** may be able to discriminate between lethal and non-lethal heart rhythms and deliver an appropriate therapy.

However, it is often desirable to establish a proper baseline of historical data by collecting a sufficient amount of data in the IMD **102**. In some examples, a "learning period" of some time (e.g., thirty days) is used to establish the baseline for one or more physiological signals. An IMD **102** may, in an example, store a moving window of data of operation, such as a time period equal to the learning period, and may use the information as a baseline indication of the patient's biorhythms or biological events.

[0045] Once the baseline is established, then acute and long-term patient conditions may be determined probabilistically. The baseline may be established by using historical patient records or by comparing a patient to a population of patients. In an example, a diagnostic technique uses a patient-based baseline to detect a change in a patient's condition over time. Examples of a diagnostic technique that uses a patient-derived baseline are described in the next section.

[0046] In an example, patient diagnostics are automatically collected and stored by the implanted device **102**. These values may be based on the patient's heart rate or physical activity over a time period (e.g., 24-hour period) and each diagnostic parameter is saved as a function of the time period. In one example, heart-rate based diagnostics utilize only normal intrinsic beats. For heart rate variability (HRV) patient diagnostics, the average heart rate can be found at each interval within the time period, for example, at each of the 288 five-minute intervals occurring during 24 hours. From these interval values, the minimum heart rate (MinHR), average heart rate (AvgHR), maximum heart rate (MaxHR) and standard deviation of average normal-to-normal (SDANN) values may be calculated and stored. In one example, the implanted device **102** computes a HRV Footprint[®] patient diagnostic that can include a 2-dimensional histogram that counts the number of daily heartbeats occurring at each combination of heart rate (interval between consecutive beats) and beat-to-beat variability (absolute difference between consecutive intervals). Each histogram bin contains the daily total for that combination. The percentage of histogram bins containing one or more counts can be saved each day as the footprint percent (Footprint %). The implanted device **102** can also provide an Activity Log[®] patient diagnostic (Activity %), which can include a general measure of patient activity and can be reported as the percentage of each time period during which the device-based accelerometer signal is above a threshold value.

Within Patient Diagnosis

[0047] In certain examples, a within-patient diagnostic technique measures short-term variance of one or more patient-related physiological parameters to detect acute changes in physiologic sensor values. The measured physiological parameters may be compared to a baseline value to detect changes that exceed a threshold value. These changes may occur within a short period before a patient experiences an onset of a physiological condition and as such, an alert may be generated when changes exceed the threshold amount.

[0048] FIG. 2 is a detailed schematic view illustrating portions of a system **200** that measures and detects variance in patient-related data to identify acute changes that may indicate an onset of a physiological condition. In the system **200**, two or more detectors **202A**, **202B**, . . . , **202N** are connected to one or more sensors **204**. Sensors **204** may

include implanted or external sensors, such as those described above. Sensors **204** may be configured to automatically collect patient-related data (e.g., a heart rate monitor) or be configured to operate by user commands (e.g., an interrogatory device with a display, or a weight scale). The patient-related data may include sensed physiological data, sensed environmental data, or data collected from a patient in response to a query or request. Examples of the sensors **204** include, without limitation, an electrocardiogram, an accelerometer, a pressure sensor, a cardiac output (CO) detector, a heart rate monitor, an interrogatory device, a weight scale, and a microphone. Examples of sensed value include, without limitation, standard deviation of averaged normal-to-normal (SDANN) cardiac depolarization interval trends, heart rate minimum (HRMin), physical activity, or a patient compliance index (as described below). Each detector **202** may include hardware or software to evaluate the one or more input signals from the one or more sensors **204**, such as to determine a value of an alert status associated with the sensor-detector pair.

[0049] Detectors **202** may be configured to provide an alert status when one or more conditions are detected. In an example, the alert status is based on comparing one or more parameters (e.g., sensed values) to one or more threshold values, such as to determine whether the one or more parameters exceeds or falls below its corresponding threshold value. Threshold values may be configured as an absolute value (e.g., a minimum or maximum acceptable safety value) or based on a difference or change from a baseline or other known value. For example, a threshold may be configured as a maximum (or minimum) percent change from a value (e.g., baseline value); as a standard deviation value from a value; or an absolute change from a value (e.g., an increase of five points). In an example, the maximum percent change threshold value is computed by using a baseline value, such that if the sensed value (or daily average of sensed values) exceeds the percent change threshold from the baseline value an alert status is found. Baseline values may be calculated using a central tendency (e.g., average, mean, median, mode, etc.) or other composite of two or more sensed values over a particular time period (e.g., day, week, month, training period, etc.). An initial threshold value may be determined using performance of the within-patient diagnostic technique during a training or learning period (e.g., the first 30 days of operation of a new device). One or more threshold values may be adjusted, automatically or manually, from the initial threshold value during later performance.

[0050] In some examples, an alert status is reflective of whether an event occurred. For example, if a patient is requested to perform an action (e.g., take medicine or exercise daily) and fails to perform the requested action, then an alert may be generated. In various examples, the alert status may be represented as a binary value, a substantially continuous value, or a discrete value. Binary values may represent, for example, whether a patient action was detected (e.g., yes/no) or whether a two-state condition exists (e.g., on/off, hot/cold). Additionally, binary values may indicate whether a patient is more or less likely to experience a health change, such as a change to quality of life, an onset of a disease state (e.g., heart failure decompensation), or death. Discrete values may indicate, for example, a multi-state condition (e.g., low/medium/high) or a scaled value, such as a subjective rating of pain on a scale

of one to five. Substantially continuous values may indicate, for example, a normalized scale, such as a scale of zero to one, however, such values may be quantized by an analog-to-digital converter.

[0051] Each alert status is communicated to a fusion machine **208** using a corresponding data pathway **206A**, **206B**, . . . , **206N**. Depending on the configuration of the detectors **202** and the fusion machine **208**, one or more of the corresponding data pathways **206** may be wired or wireless. For example, in certain examples, the detectors **202** and the fusion machine **208** are integrated into an IMD. In other examples, one or more detectors **202** may be located separate from the IMD and possibly separate from each other. In this case, the fusion machine **208** may be integrated into one or more detectors **202** or it may comprise a separate machine.

[0052] Moreover, although the example illustrated in FIG. 2 depicts a detector **202** associated with an alert status value (communicated over a data pathway **206**), sensors **204**, detectors **202**, and data pathways **206** may be combined or multiplexed in various ways. For example, a detector **202** may use one or more sensors **204** to determine an alert status value. As another example, two or more detectors **202** may be used in combination to determine a particular alert status value. In another example, sensors **204** or detectors **202** may be reused in multiple combinations or permutations with other sensors **204** or detectors **202** to derive alert status values. Such combinations or permutations of sensors **204** or detectors **202** may be advantageous to provide an alert status value that reflects a more complex decision or determination.

[0053] The two or more detectors **202** may communicate their alert status values to a first fusion module **210**. The first fusion module **210** calculates an alert score using the alert status from one or more detectors **202**. In an example, the first fusion module **210** uses a weighted function to calculate the alert score. The weights in the weighted function may be adapted for a particular patient or a particular population of patients, such as by adjusting the weights based on prior knowledge of the suspected patient condition and the types or numbers of sensors used. For example, patients at high risk of heart failure decompensation may exhibit an unusually low physical activity or heart rate variability (HRV). By increasing the sensitivity of these sensors (e.g., decreasing a threshold value), a lower physical activity value or a lower HRV value may be detected earlier.

[0054] In another example, weights in the weighted function may be based on time, the number or types of sensors, or a confidence value associated with a sensor **204** or detector **202**. For example, more recent alert values may be weighed more than less recent alert values; a particular type of sensor may be considered more reliable and assigned a comparatively higher weight than sensors considered less reliable. As another example, in a situation where more than one sensor is used to determine an alert value, the number of sensors used to determine such an alert status may be used to assign a weight, such that alert values calculated using more sensors may be considered more reliable and thus, have a higher weight compared to alert values calculated using fewer sensors. In yet another example, weights may be assigned using a cost function. For example, individual decisions could be weighted according to their reliability,

such that the weights may be regarded as a function of the probability of miss or the probability of false alarm of an individual detection.

[0055] In addition, weights may be modified, such as between alert score calculations, to adaptively adjust to changing conditions. The alert score may be calculated periodically or recurrently, such as hourly, daily, or weekly. In an example, after calculating the alert score, the first fusion module 210 stores the alert score in an alert score memory 212. The history of alert scores may be used to track changes or in further processing, as described below. The alert score memory 212 may include a database, files, random access memory, or other storage unit.

[0056] The alert score may be communicated from the first fusion module 210 to the second fusion module 214. In another example, the second fusion module 214 accesses a storage unit, such as the alert score database 212, to obtain the current alert score. The second fusion module 214 also accesses the same or a different storage unit to obtain one or more historical alert scores. In an example, a fixed number of historical alert scores are obtained from the storage unit, such as to obtain a “moving window” of the most recent historical alert score data. For example, when alert scores are calculated and stored weekly, then three prior calculated alert scores may be obtained, along with the current alert score, to effectively view a month’s worth of alert score data. The second fusion module 214 uses the one or more historical alert scores in combination with the current alert score to calculate a combined alert score (CAS). In an example, the CAS is a weighted function of the alert scores. In various examples, weights in the weighted function may be equal, unequal, adaptive based on one or more patient characteristics, or based on time (e.g., more recent alert scores are given a higher weight, being considered more relevant, while less recent alert scores are given a lower weight).

[0057] In an example, the second fusion module 214 communicates the CAS to a comparator module 216. The comparator module 216 compares the CAS to a threshold CAS value. In various examples, the threshold CAS value is an absolute value, or may be based on a percent change from a baseline or other standard value. In other examples, the threshold CAS value is dynamic or static. For example, the threshold CAS value may be manually set by a user. The user may change the value at recurrent or periodic intervals. For example, a user may set the CAS threshold to some arbitrary high value and then dynamically or manually adjust the CAS threshold, such as to fine tune false positive or false negative rates (e.g., specificity or sensitivity).

[0058] Sensitivity generally refers to the ability of the detection scheme to effectively detect a particular result. Sensitivity can be expressed with the formula: sensitivity=(true positives)/(true positives+false negatives). Thus, a higher sensitivity generally indicates that an analysis correctly characterizes more true positives or eliminates false negatives.

[0059] Specificity generally refers to the ability of the detection scheme to avoid improper classifications. Specificity can be expressed with the function: specificity=(true negatives)/(true negatives+false positives). Thus, a higher specificity generally reflects more accurate classification of true negatives or reduction of false positives.

[0060] In other examples, the threshold CAS value is determined automatically. In an example, the threshold

updater module 224 uses one or more input parameters to configure or update the threshold CAS value. Input parameters may include things such as the time, the number of sensors or detectors, one or more patient characteristics, a physician’s or clinician’s preference, the previous threshold CAS value, or the CAS. The threshold updater module 224 may communicate the current threshold value to the comparator module 216 for use in the comparison. In certain examples, the threshold CAS value is established using a constant false alarm rate (CFAR) technique, such as described in Siejko et al U.S. patent application Ser. No. 11/276,735, entitled PHYSIOLOGICAL EVENT DETECTION SYSTEMS AND METHODS, filed on Mar. 13, 2006, which is assigned to the assignee of the present patent application, and which is incorporated herein by reference in its entirety, including its description of CFAR event detection techniques.

[0061] When the CAS exceeds the threshold CAS value, then the comparator module 216 provides an indication of this state to the alert module 220. The alert module 220 may, in some examples, record one or more aspects of the generated alert, such as in alert history database 222. The alert module 220 may communicate the alert state to a communication module 226, for communication to a user (e.g., a physician or clinician).

[0062] While FIG. 2 illustrates an example of a system 200 that implements fusion logic in a fusion machine 208, portions of the processing may occur at the sensor 204, detector 202, or be distributed among several processing machines. For example, a sensor 204 or detector 202 may include memory to record one or more sensed values over time and may only transmit a central tendency (e.g., mean, median, or mode) to the first fusion module 210 for further processing. As a further example, the fusion machine 208 may be located at a central server, programmer, or patient device.

[0063] FIG. 3 illustrates a method 300 of using a composite alert score to detect an increased likelihood of a disease state or onset of a physiological condition. At 302, one or more alert status values are detected. Alert status values may be binary (e.g., on/off, yes/no, high/low), substantially continuous (e.g., 1.4, 2.9, 9.34) or discrete (e.g., 1 out of 5, 2 out of 4). At 304, an alert score is calculated using the alert status values. In an example, the alert score is a weighted function, such that:

$$\text{Alert Score (AS)} = \text{Alert}_1 * w_1 + \text{Alert}_2 * w_2 + \dots + \text{Alert}_m * w_m$$

[0064] where weights w_1, w_2, \dots, w_m may be modified to weigh one alert value higher or lower than another alert value based on a factor, such as a patient characteristic or a sensor confidence level. In an example, alerts may be temporally related. For example, an alert status may be detected on a periodic or recurrent basis, such as daily, from a particular sensor. In another example, alerts may be otherwise associated. For example, alert statuses may be detected from one or more of similar types of sensors (e.g., implanted and external heart rate monitors), such that if an alert is detected from one sensor, then the alert may be considered to be active for all related or associated sensors. In another example, all related or associated sensors are polled and an alert is detected when some plurality or all concur on an alert state.

[0065] At 306, two or more alert scores are combined into a composite alert score (CAS). In an example, the CAS is a weighted function of alert scores, such that:

$$\text{Composite Alert Score (CAS)} = AS_i * w_i + AS_{i-1} * w_{i-1} + \dots + AS_n * w_n$$

[0066] where weights w_i, w_{i-1}, \dots, w_n may be modified to weigh one alert score higher or lower than another alert score based on a factor, such as time, patient changes over time, or the like. In an example, AS_i is the alert score of the current period and AS_{i-1} is the alert score for the previous period, etc. Periods may be days, weeks, months, or some other regular time interval. At 308, the CAS is compared to a threshold value. In an example, the threshold is fixed, however it may be adapted, such as for particular patients or over time in other examples. When the CAS is over the threshold value in this example, then at 310, an alert state is set. If the CAS does not exceed the threshold value in this example, then at 312, the alert state is not set. In various examples, the alert state may indicate one or more of an onset of a physiological condition, a change in a physiological condition, or a predictive measure of a possibility of an onset of such a physiological condition. For example, the alert state may be used to assist in predicting physiological or patient-related events, such as HF decompensation, lead fracture, sudden cardiac death (SCD), or myocardial infarction (MI). Additionally, the alert state may be indicative of or used for determining a likelihood of a change in a patient's quality of life or a likelihood of patient death in a particular time period or time frame. Portions or all of the method 300 may be executed on different processing machines, for example, method 300 could be executed by a central server, a programmer, or a patient device.

[0067] FIG. 4 is a diagram illustrating an example of relationships between alert values, alert scores, and composite alert scores. In an example, alert values 400 are sensed or detected over time and associated with a particular sensor 402. Alert values 400 may be combined first with respect to a particular sensor 402, for example, AS_1, AS_2, \dots, AS_z 404. The alert scores combined with respect to each sensor may then be combined to form the composite alert score, CAS 406. Alternatively, alert values 400 may be combined first with respect to a particular time slice, such that AS_1, AS_2, \dots, AS_N 408. Similarly, the alert scores combined with respect to each particular time slice may then be combined into a composite alert score 406. As described above, the calculation of the alert scores, either with respect to a particular sensor or with respect to a particular time slice, may include the use of a weighted function. In addition, the calculation of the combined alert score 406 may include a weighted function.

[0068] In other examples, as illustrated in FIGS. 5-6, alert scores may be calculated using various combinations of alert values. FIG. 5 is a diagram illustrating relationships between alert values, alert scores, and composite alert scores. In FIG. 5, alert values 500 are used in various combinations to determine alert scores 502A, 502B, 502C. For example, alert score AS 502A is composed of alert values A_i and A_j , alert score AS' 502B is composed of alert values A_y and A_z , and alert score AS'' 502C is composed of alert values A_j and A_y . Alert scores 502A, 502B, 502C may be combined to form a composite alert score 504. Alert values 500 may be obtained from the same sensor over time or from two or more sensors. In an example, when alert values 500 are obtained from the same sensor, the alert values 500 may be determined at

periodic or recurring time intervals, such as daily, hourly, or the like. In another example, when alert values 500 are obtained from two or more sensors, the values 500 may be obtained at approximately the same time.

[0069] FIG. 6 illustrates another relationship between alert values, alert scores, and composite alert scores. Provided an array or matrix of alert values 600, various subsets of alert values 600 may be combined to form alert scores, such as AS_1 602 and AS_2 604. Alert scores 602, 604 may be combined to form a composite alert score 606. As described above with reference to other examples, relationships illustrated in FIGS. 5 and 6 may include weighted functions.

Surrogate Measure of Patient Compliance

[0070] Measurements of patient compliance may provide a general indication of how closely a patient follows a physician's or clinician's direction or instruction. Patients who are non-compliant in one or more ways, such as concerning diet, exercise, or medicine, may also be non-compliant with regard to other medical advice or instruction. Non-compliant patients may benefit from closer observation or follow-up by their physician or clinician. The observation or follow-up may assist the physician or clinician in managing an increased medical risk due to non-compliance and increasing the patient's overall compliance. In addition, non-compliant patients may benefit from re-evaluating, modifying, ceasing, or implementing new therapies.

[0071] In some examples, patient compliance may be measured by detecting whether one or more requested actions were performed by the patient. Performance may be analyzed using one or more indexes, such as with respect to frequency, time, or technique or the like. For example, a patient who is requested to weigh himself unclothed daily at 9:00 AM may have a high frequency compliance score if he consistently weighs himself every day. However, if the weigh-ins are sporadically timed, for example from 8:30 AM to 11:00 AM, then the patient may be associated with a relatively lower time compliance score. In addition, if the patient's weight measured during weigh-ins differs by more than a few pounds, which may be considered normal daily weight variance, then it may be deduced that the patient was clothed during some weigh-ins and thus, may be associated with a relatively lower technique compliance score.

[0072] Thus, frequency compliance may be measured by a frequency compliance index score, and can be conceptualized as how often the requested action is documented. In an example, the frequency compliance score is measured as a ratio of missed measurements over a particular time period. In such a configuration, a higher frequency compliance score may indicate a lower patient compliance. In another example, an inverse ratio is used, that is, the number of successful measurements over a particular time period, where a higher compliance score may indicate a more patient compliance.

[0073] In addition, time compliance can be conceptualized as when an action is performed or documented, such as what time of day or what day of week. Time compliance may be measured by a time compliance index score. In an example, a variance or standard deviation or other measure of variability of the time of performance with respect to the requested time is calculated over a time period. In such a configuration, a higher variability score may indicate less patient compliance. The time compliance index score may be a function of such a variability score, such as a normal-

ized inverse of the variability score such that a higher time compliance index score indicates a generally more compliant patient.

[0074] Technique compliance may be viewed as how correctly or how completely a patient conducts or performs a requested action. By using one or more objective auxiliary measurements, a technique compliance index score may be derived. Not every requested patient action may be tested for technique compliance as some actions are too simple and others do not provide objective metrics to measure technique.

[0075] Patient actions may be detected using an interactive or interrogatory device (e.g., a patient monitor or personal computer), one or more external devices (e.g., a weight scale or blood-pressure cuff), one or more implanted devices (e.g., a cardiac rhythm management (CRM) device, accelerometer, or heart monitor), or any combination thereof. Additional examples of external sensors include, but are not limited to, a peak flow monitor, a glucose monitor, an oxygen saturation monitor, or an electrocardiogram monitor.

[0076] Requested patient actions may include one or more actions related to ongoing health care or therapy. For example, a patient may be requested to measure their blood pressure or weight at regular intervals. Requested patient actions may also include non-health care or non-therapy related actions. For example, a patient could be requested to report the outside temperature daily at a particular time. Such an action is not directly related to a patient's health care or therapy, but may be used as a surrogate or indirect measure of compliance. Patients who are generally more compliant to arbitrary instructions may also be more compliant to health care directives.

[0077] Monitoring one or more patient compliance index scores may provide an indication of a change in physiological or psychological disease state. Patients may be compared to a population of patients to determine whether they fall outside a particular level of compliance or range of compliance index scores (e.g., a median or mode of a patient population). The population of patients may be selected using one or more of the patient's particular characteristics, such as age, weight, gender, disease risk, current medical status, or the like. In addition, patient compliance scores may be used in auxiliary processes, such as a within-patient diagnosis, as described above. An acute change in a patient's compliance over time may indicate the onset of a physiological or psychological condition or disease state, such as heart failure decompensation, as an illustrative example. In other examples, a change in a patient's compliance may be indicative of or used for determining a likelihood of a change in a patient's quality of life or a likelihood of patient death in a particular time period or time frame.

[0078] A patient may be characterized into a class of compliancy. Grouping patients that are generally more compliant and patients that are generally less compliant may be used to determine which patients may require more observation, clearer instruction, or different therapy.

[0079] Another use of surrogate measures of patient compliance is to identify or label data as outliers. In other words, collected patient data, which may include subjective response data, measured physiological data, or other detected, measured, or sensed data related to a patient, may be considered suspect or viewed with less confidence if the patient's surrogate measure of patient compliance is below a threshold acceptable level. In an example, patient data

(e.g., electrograms, physical activity levels, HRV, heart sounds, etc.) recorded around the same time that the patient compliance score was below a threshold is flagged. Flags may be used as a measure of the quality of the measured patient data. For example, a patient compliance index score may be based on timely and consistent patient weigh-ins using an external weight scale. When the compliance index score falls below a threshold, patient weight values obtained may be considered suspect and may be weighted less in a within-patient or between-patient analysis. In another example, when the compliance index score falls below a threshold, physiological sensor data may instead be given an increased weight on the grounds that poor compliance can inferentially indicate that the patient may not be feeling well. This may be useful, for example, when the particular physiological sensor data is believed to be relatively independent of the particular patient compliance assessment technique being used.

[0080] Several modes of analysis are illustrated in FIGS. 7 and 8. FIG. 7 illustrates an example of a method 700 of using sensed patient actions to determine a level of patient compliance. The method 700 illustrated in FIG. 7 detects and monitors patient actions in response to a request. At 702, one or more occurrences of a patient action are detected. Patient actions may be in response to a request for such an action by a clinician, therapist, or physician. For example, a patient may be requested to log onto a website daily and answer one or more questions, which need not be related to the patient's health or current therapy. When a clinician asks a non-patient health related question, such as "Is it cloudy outside?", the clinician may be more interested in whether the patient responded, and when the patient responded, than whether the response is correct. In another example, a patient may be requested to take and report their blood pressure daily. Such a request may be related to the patient's current therapy or health monitoring, but for the purposes of measuring and determining patient compliance, the value of the blood pressure reading is irrelevant—the requesting physician or clinician may be more interested in the regularity or proper performance of the patient's actions. Some requested actions may be relatively simple, such as pressing a button on a user-interface display daily at a particular time. Other requested actions may be more complex, such as for example, accessing and interacting with a particular website.

[0081] At 704, a patient compliance index is calculated. In an example, the patient compliance index is calculated using one or more of a frequency compliance value, a time compliance value, or a technique compliance value. In an example, the patient compliance index is normalized, such as to provide a range of values from zero (least compliant) to one (most compliant). In some examples, the patient compliance index is calculated using two or more values in a weighted function. In an example, the weighted function is a function of an aspect of a detected responsive patient action. For example, the weighted function may focus on the time compliance of the patient's actions over a period of time. The weighted function may weigh more recent occurrences more than less recent occurrences. In another example, the weighted function is a function of two or more aspects of a detected responsive patient action. For example, given a patient action, time compliance may be considered more important and thus given a higher weight in the weighted function than technique compliance. In another example, different weights are distributed both temporally

and across different aspects of a detected patient action. Weight factors may also be related to the number or type of sensors used, one or more patient characteristics (e.g., health trends or risk stratification), or a patient population, in various examples.

[0082] At 706, the patient index is compared to one or more threshold values. In various examples, the threshold values may be an absolute value, a trended value, a population-based value, or the threshold value may be manually selected, e.g., by a user, such as a physician. Threshold values may define a minimum or maximum expected value, such that when the patient falls under a minimum threshold or exceeds a maximum threshold value, a resulting particular action or state (e.g., an alert or alarm) may occur. Threshold values may also be used to define an inner or outer range of expected or accepted values. For example,

[0083] At 708, if the patient index violates a threshold value or condition, for example when a value is outside of a range bounded by one or more threshold values, then an alert is generated. The alert may be communicated to a user, such as a physician, or be used in further processing, such as in determining an alert score or a composite alert score, as described above.

[0084] The index score and one or more details about the alert state, e.g., whether an alert was generated, to whom it was communicated if there was an alert, etc., can also be stored at 710. The compliance index or alert may be provided to one or more other systems, processes, or devices, for example to record and maintain a patient history or for quality assurance evaluation of the system. Recording patient compliance index scores over a period of time may be advantageous to analyze or evaluate one or more trends in the patient's compliance activity.

[0085] While FIG. 7 illustrates a method 700 that emphasizes detecting and monitoring a single type of requested patient response, FIG. 8 illustrates an example of a method 800 of determining a compliance index over two or more different patient responses. In addition to being an indicator of patient compliance, monitoring more than one patient response may be advantageous, such as to determine a secondary physical, physiological, or psychological condition. For example, a patient may be requested to weigh themselves daily and also to report the outdoor temperature using a handheld interrogatory device (e.g., a patient monitoring device). When the patient fails to weigh themselves over several days, but continues to report the outdoor temperature using the handheld interrogatory device, it may be inferred by the attending physician that the patient may be physically unable to get to the bathroom to weigh himself. The inference may be supported by a deduced fact that the patient is still capable of reporting the temperature from using the handheld patient monitoring device, which may be situated more conveniently, such as beside the patient's bed. In such a situation, the physician may wish to follow up to ensure that the patient is physically stable. Detecting the presence or absence of data or other trends may be useful to determine or predict patient problems, such as heart failure decompensation, loss of cognitive function, or physical incapacity.

[0086] At 802, two or more occurrences of different patient responses are detected. Detection may be automatic or manual. Examples of an automatically detected patient response includes using a software program or other programmable device to telephone or email a patient daily at a

particular time and detect a patient response. Other examples include sensors in implanted or external devices to detect things, such as physical activity levels of the patient, physical location of the patient (e.g., using a GPS device to detect whether the patient has left their house in a particular time period), or the like. Examples of manual detection include requesting that a patient measure themselves daily, such as by using a network-enabled weight scale connected to a centralized patient management system, or having a live operator or other personnel call or visit the patient daily to determine whether the patient was compliant that day.

[0087] At 804, for detected occurrences, the occurrence is analyzed at 806. Analysis of the occurrence may be similar to that described with reference to method 700 in FIG. 7. For example, one or more aspects of the occurrence may be analyzed, such the time regularity, frequency regularity, or technique correctness.

[0088] At 808, a compliance score is determined for the particular occurrence. The compliance score may be a weighted function of one or more aspects of the occurrence. The compliance score may also be a weighted function over time, such as weighing several successive occurrences in a particular time period.

[0089] At 810, the compliance scores of the two or more occurrences of different patient responses are combined into a composite compliance index. The composite compliance index may be computed using a weighted function. The weights in the weighted function may be static or dynamic. The composite compliance index may be stored and provided to other systems, processes, or devices.

[0090] FIGS. 9A-9F are charts illustrating examples of recorded patient actions in response to at least one specific request. In the example illustrated, the specific request is for the patient to weigh himself daily unclothed at 7:30 AM. The first chart 900 in FIG. 9A illustrates conceptualized (not real) data illustrating a series of weight measurements detected in response to the specific request. As illustrated, the patient's normal weight is in a range of approximately 114 kg and 117 kg. In an example, an allowable daily weight variance is provided to account for natural weight changes.

[0091] The second chart 902 in FIG. 9B illustrates the recorded time of each weigh-in. In an example, an allowable time variance is provided to allow for some flexibility in the timing of the patient's responsive action. In another example, any variance from the exact specified time may result in a lower compliance score.

[0092] The third, fourth, and fifth charts 904, 906, 908 illustrated in FIGS. 9C-9E respectively illustrate a trended time compliance score, a trended frequency compliance score, and a trended quality compliance score (technique compliance). In an example, the trended time compliance score, as illustrated in the third chart 904, is computed using the previous week's worth of recorded patient actions. In an example, the trended time compliance score is normalized, such as from a score of zero to one. Here, the specified time to perform the action is 7:30 AM. Using an allowable time variance of ± 30 minutes in this example, when a patient perform the requested action (weighing in) at any time between 7:00 AM and 8:00 AM, the patient is deemed to be in full compliance with respect to time. Using the prior seven day's data, the first value 910 of trended time compliance is a 1.0 because each of the prior seven day's weigh-ins were performed within the 7:00 AM to 8:00 AM allowable time range. When the patient fails to perform the

requested action within the allowable range, such as at **912**, then the corresponding trended time compliance score falls, such as at group **914**.

[0093] The fourth chart **906** in FIG. **9D** illustrates a trended frequency compliance score based on the data in the first chart **900**. Similar to the time compliance scores, the trended frequency compliance score is based on the previous week's worth of data, in an example. Here, when the patient performs the action, a corresponding daily frequency compliance score is one, and when the patient fails to perform the action, the corresponding daily frequency score is zero. The trended frequency compliance may be calculated as a linear function of the previous week's daily frequency compliance scores, such as

$$\frac{\sum_{j=0}^6 fc_j}{7},$$

where fc_j is the daily frequency compliance score (1 if the patient performed the requested action and 0 if the patient did not). As illustrated, the trended frequency compliance score falls off, see group **916**, when a patient action is not detected, such as at **918**, until the patient has performed the requested action for a full week's time with regularity. The trended frequency compliance score will then be adjusted to a value **920** to indicate full compliance.

[0094] The fifth chart **908** in FIG. **9E** illustrates a trended quality compliance score. Quality compliance may also be referred to as technique compliance. Some patient actions may be analyzed for such a compliance using the measurement value or other aspect of the requested patient action to infer or deduce a level of quality or correct technique used by the patient when executing the requested action. Similar to the trended time compliance score and the trended frequency compliance score, the trended quality compliance score may be based on prior occurrences of the patient's responsive action. In this example, the window or number of occurrences used to calculate the trended quality compliance score is illustrated as being five days. Here, the specific instructions included the instruction for the patient to measure their weight unclothed. Recognizing data outliers, such as those at **922**, which are abnormally high in comparison to other data points in the first chart **900**, it may be inferred or deduced that the patient improperly wore clothes while weighing in. Thus, the daily quality or technique compliance score is lower and corresponding trended quality compliance score falls off, such as at **924**.

[0095] One or more of the trended time compliance score, trended frequency compliance score, or trended quality compliance score, may have an associated threshold value, such that if the trended compliance score falls below the threshold value, an alarm is issued. Threshold values are illustrated in the third, fourth, and fifth charts **904**, **906**, **908** as dashed lines **926**, **928**, **930**, respectively. The threshold may be based on a statistical or probabilistic model (e.g., using a population database or previous measurements from a particular patient) or may be maintained by a user (e.g., a physician or clinician). For example, in some situations a user may want a higher or lower sensitivity to changes in different measures of compliance. Manually raising or lowering the threshold value for one or more of the trended

compliance scores may allow the user to manage false positive or false negatives (e.g., specificity or sensitivity) of compliance alerts. A CFAR technique can also be used, as discussed and incorporated above.

[0096] In some examples, a combined compliance score may be calculated, as illustrated in the sixth chart **932** in FIG. **9F**. The combined compliance score may be a weighted function of one or more of the trended time compliance score, the trended frequency compliance score, or the trended quality compliance score. In the example illustrated, the combined compliance score is a weighted linear function of the trended time compliance score, the trended frequency compliance score, and the trended quality compliance score, each with equal weights. In an example, the combined compliance score may also be trended with respect to time. A threshold value may also be provided (illustrated as dashed line **934**), such that if the combined compliance score is calculated to be less than the threshold value, an alarm is issued.

[0097] As an extension of the example illustrated in FIGS. **9A-9F**, two or more requested patient actions may be recorded and analyzed. The combined compliance score, as shown in the sixth chart **932**, may be a function of one or more of the time, frequency, or quality compliance scores from each of the two or more requested patient actions. One or more of the requested patient actions may be weighed differently from each other in the combined compliance score. In addition, each element of the combined compliance score (e.g., time, frequency, or quality) may also have an associated weight, which may differ from one another.

Between-Patient Diagnosis

[0098] Although monitoring a patient's physiological or other health-related indications over time may provide some insight into the patient's health-related trends, analysis may be made more complete by including a between-patient diagnosis technique. Between-patient diagnosis leverages previously recorded and documented patient data for the benefit of a current patient. By comparing the current patient to a group of similarly situated patients, probabilistic determinations may be made. For example, based on comparisons to a reference group or control group of patients, a particular patient may be said to be more similar or less similar to the reference group. As another example, using one or more other comparisons to the reference group, the particular patient may be probabilistically deemed more or less likely to experience a health event in a given amount of time (e.g., a specified "prediction time interval"), relative to the reference group. Using one or more such probabilistic measurements, a physician may change diagnosis or adjust or adapt therapy to increase the quality of life of the particular patient. For example, a physician may increase the number of follow up visits or shorten the length of time between successive follow up visits, tune one or more thresholds on one or more alert methods, or alter medication to be more aggressive or less aggressive.

[0099] In an example, a between-patient technique provides a population-based stratification of patients according to their risk of a health condition (e.g., heart failure decompensation) within a particular time frame (e.g., three months). For example, a given patient may be classified as "high," "medium," or "low" risk when compared to a reference patient population. The technique can include comparison of one or more heart rate variability (HRV)

diagnostics of a patient with a model of one or more similar diagnostics of a reference population. The reference population may include one or more typically, multiple patients, that may be similar to the current patient, such as being prescribed with similar medical devices or associated with similar therapies. The between-patient technique results in an index value, which may indicate whether (or a degree to which) the patient is similar to the reference population.

[0100] In an example, one or more threshold values are used to categorize or bin the patient into a particular group associated with a risk level or category. For example, threshold values may be established using quartiles, deciles, quintiles, or the like. In other examples, a logarithmic, exponential, or other distribution function (e.g., a Bell curve) may be used to stratify a patient population into two or more risk categories or levels. Threshold values may be adjusted, such as periodically or recurring. Adjustments may be performed automatically or manually, in various examples. For example, when a reference patient population is changed or replaced, such as when new patients are added to an existing reference group, one or more threshold values may be modified to maintain a proper population distribution. Such an adjustment may occur when triggered by a user (e.g., a physician) who has confirmed the use of the revised patient population reference group. An adjustment to one or more threshold values may occur automatically, such as when a system detects the availability or use of a revised patient population reference group.

[0101] While examples illustrating the use of HRV diagnostic values are described, other physiological, psychological, or other patient indications may be used to compare a particular patient with a reference group. For example, heart rate (HR), physical activity, blood pressure, heart sounds, intracardiac or thoracic or other impedance, or other metrics may be used for categorization or comparison.

[0102] Constructing an appropriate reference group may impact the accuracy or value of any predictive calculations based on comparisons between a patient and the reference group. As such, the reference group may be selected based on one or more similarities with the patient in question. Similar patients may include:

[0103] patients who participated in the same controlled study;

[0104] patients who are managed by the same or similar health provider, such as the same implant provider or the same therapy provider;

[0105] patients who are viewed as stable (e.g., did not die in a particular time, did not decompensate within a particular time, are compliant in their medication or other prescriptions, report a high quality of life, or have not used the health care system in a particular time period);

[0106] patients with similar age, gender, ethnicity, geography, clinic, left ventricular ejection fraction (LVEF), New York Heart Association (NYHA) heart failure classification, HF etiology, body mass index (BMI), blood pressure, Six-minute walk test (6MW), quality of life (QoL);

[0107] patients who have survived for a particular time frame (e.g., 5 years after implant or 6 months after change of therapy), patients who have not decompensated in a particular time frame (e.g., in the last 9 months)

[0108] patients using the same or similar medication;

[0109] patients with one or more similar co-morbidities or arrhythmia history;

[0110] patients with a similar device implant or device implant history.

This list of similarity characteristics is not meant to be exhaustive or complete, but merely illustrative of examples of some characteristics that may be used as parameters to group or associate patients into a reference group.

[0111] Reference group patients may be selected from public or private databases. For example, patients may be selected from a database associated with a remote patient management system, such as LATITUDE® as provided by Boston Scientific Corporation's Cardiac Rhythm Management (CRM) group of St. Paul, Minn. In addition, reference groups may be static or dynamic. Static reference groups may be comprised of patients having records that existed in a database or system at the time the current patient enrolled or entered the database or system. Thus, static reference groups may represent a snapshot of patients who existed in the system at a particular time, such as at the time of enrollment of a new patient. Static reference groups may not be updated. For example, for a particular diagnostic technique, a snapshot static reference group of patients is used to satisfy assumptions made in the analysis of the particular diagnostic technique. Changes in the static reference group may invalidate the results of such a strict diagnostic technique.

[0112] Dynamic reference groups may include dynamically updated static reference groups or true dynamic reference groups. Dynamically updated static reference groups may be updated recurrently or periodically, such as weekly, monthly, seasonally, or annually. Such an update may create a new static reference group, to be used for a period of time. Dynamically updated static reference groups may also be updated at a triggering event. Examples of triggering events include an interrogation of a current patient's implantable device, an implantation of a new patient device, the introduction of a new patient device (e.g., a release of a new model, firmware, software, or other component of a patient device), the introduction of a new drug, or when a new revision of the reference group is approved by an authority, such as the Food and Drug Administration (FDA). Additional examples of triggering events include a detected change in a patient's health condition, a change of a standard of care, a change in a population statistic (e.g., lifestyle, eating habit, education, birth rate, death rate, or habits), or the like. Triggering events may also include one or more user commands to update a reference group. The user commands may include one or more parameters, such as patient age; gender; comorbidity; implant type; or other physiological, environmental, cultural, or patient-related data. In an example, the parameters act as a filter that defines a patient subpopulation, which is used as a dynamically updated patient reference group. In various examples, the parameters may be combined using logical conjunction, disjunction, or both.

[0113] A true dynamic reference group typically includes a patient reference group that modifies its contents automatically, such as in near real-time. For example, a true dynamic reference group may be defined using one or more parameters, such as those described above, to characterize and select a subpopulation of patients. When a patient experiences a change in a physiological, environmental, or other patient-related characteristic, the patient may auto-

matically be added to or removed from the true dynamic reference group. In effect, in an example, a true dynamic reference group may be considered a dynamically updated static reference group that is updated when the reference group statistic (e.g., distribution) is requested or accessed. In another example, a true dynamic reference group may be viewed as a dynamically updated static reference group that is triggered to update at a small increment in time, such as every second, to make the reference group appear as a nearly real-time, dynamic view of a patient subpopulation.

[0114] FIG. 10 illustrates an example of a method 1000 of deriving a probabilistic index based on a particular patient compared to a patient population. At 1002, one or more physiological indications are received. Examples of physiological indications include sensed cardiac signals, physical activity level, and SDANN or Footprint % indices. Footprint % indices may include a measurement of an area under a 2-D histogram of heart rate variability of a patient. Physiological indications may be detected or provided by implanted or external patient monitoring devices. For example, an implanted cardiac rhythm management device may include electronics, memory, or other components to detect or store heart rate intervals, implantable electrograms, electrogram templates for tachyarrhythmia detection or rhythm discrimination, pressure (e.g., intracardiac or systemic pressure), oxygen saturation, physical activity, heart rate variability, heart sounds, thoracic or intracardiac or other impedance, respiration, intrinsic depolarization amplitude, heart rate, data related to tachyarrhythmia episodes, hemodynamic stability, therapy history, autonomic balance, heart rate variability trends or templates, or trends, templates, or abstractions derived from sensed physiological data.

[0115] At 1004, a patient reference group is determined or otherwise mapped to the current patient. As described above, the patient reference group may comprise patients from a pool of patients that share one or more similarities with the current patient. Increasing the number of similarities shared between the reference group and the current patient may increase the quality or accuracy of predictive calculations. Determining a relevant reference group may include considering one or more other factors, such as age, gender, medication, medical history, or the like, such as those described above.

[0116] At 1006, a reference group dataset is determined. In an example, the reference group dataset includes patient data of patients in the reference group, where the patient data is substantially similar to the physiological indications received at 1002. For example, if at 1002, a patient's physical activity levels are being monitored and reported by an internal or external patient device, then at 1006, patient data associated with physical activity level from the patient reference group is selected as the reference group dataset.

[0117] At 1008, a model of the reference group dataset is determined. In an example, the model is a probabilistic model and calculated using a probability function. In a further example, the probability function includes a cumulative distribution function (CDF). For example, the model may include a series of 1-dimensional (1D) empirical cumulative distribution functions of the reference group's weekly-averaged activity, SDANN, and Footprint % values. As another example, the CDF may include a single joint multivariable CDF with either a diagonal or full covariance matrix. In another example, the probability function includes

a probability distribution function (PDF). In an example, a probabilistic model may include a series of 1-D probability distribution functions (PDF), where a particular PDF models a distinct parameter. In another example, the model may include a single joint multi-dimensional PDF, where each dimension models a distinct parameter. For example, a PDF may include a joint multivariable PDF with either a diagonal or full covariance and may be estimated over the reference group patients' weekly-averaged activity, SDANN, and Footprint % values. Other physiological parameters may be used in the modeling and comparison, such as average heart rate, maximum heart rate, minimum heart rate, respiration rate, amplitude of S3 heart sound, or pulmonary artery pressure.

[0118] At 1010, the current patient's received physiological value can be used to determine an index value based on the model of the reference group dataset. The index value may be calculated periodically or recurrently, such as daily, weekly, or monthly, such as by using average values for the periodic or recurrent time interval. In an example, 1-dimensional CDFs can be used as "look up tables" to determine what percentage of reference group patients had physical activity levels less than or equal to the current patient's physical activity level. A similar process may be used with SDANN and Footprint % values. For each percentile, values near 0.5 can indicate that the patient is in the 50th percentile of the reference group (e.g., the patient is similar to the reference group), while values near 0 or 1 indicate that the patient is dissimilar to the reference group. The individual indices may be combined into a composite index, such as, for example, by multiplying, adding, or otherwise mathematically combining the individual indices.

[0119] In another example, a probability distribution function (PDF) can be used to model the reference group dataset. For example, a PDF may be constructed using the reference patients' activity, SDANN, and Footprint % values. The current patient's physiological values can be compared to an estimated PDF to determine the patient's index value. The index value may include the negative log-likelihood that the current patient's set of activity, SDANN, and Footprint % values belong to the PDF. In certain examples, the index value may also be the area under the PDF enclosed by (or outside of) an equiprobable contour that represents the probability that the current patient's set of values belong to the estimated PDF. In either case, a low (or high) index value indicates how similar (or different from) the current patient is compared to the reference group.

[0120] The index value may be advantageous to provide easier comparison between patients, provide a reference value that is easy to interpret, provide easier identification of any outlier values, or provide more insight into one or more correlations between patient physiological indications and probabilistic diagnoses. In some examples, the index value may indicate how likely a patient is to enter or recover from a disease state in a particular amount of time. As an illustration, the index value may be interpreted to indicate the likelihood of a patient to experience heart failure decompensation in the next six months, such as relative to other patients in the patient reference group. For example, Hazard ratios or Cox Proportional Models may be used to determine such a likelihood. In other examples, the index may be used to indicate how likely a patient is to experience a change in health, such as an increase or decrease in quality of life, or a likelihood of death in a particular timeframe.

[0121] FIGS. 11A-11C illustrate examples of a physical activity cumulative distribution function (CDF) chart 1100 in FIG. 11A, an SDANN CDF chart 1102 in FIG. 11B, and a Footprint % CDF chart 1104 in FIG. 11C. In FIG. 11A, the activity CDF chart 1100 includes an activity value 1106 along the x-axis and an activity index 1108 along the y-axis. The activity value 1106, in an example, represents the percentage of time a patient is considered active using a threshold, which may be based on heart rate, blood pressure, accelerometer, or one or more other indications of physical activity. The activity index 1108 represents the percentile of a particular patient with a particular activity value 1106. For example, a patient with an activity value 1106 of 10 has a corresponding activity index 1108 of approximately 0.62, which indicates that the patient is in the 62nd percentile of active patients, e.g., the patient is more active than 62% of the patients represented.

[0122] Similarly, in FIG. 11B, the SDANN CDF 1102 includes a standard deviation value along the x-axis 1110 and a SDANN index 1112 along the y-axis. In an example, the SDANN index 1112 represents the percentage of patients that have a SDANN value equal to or less than the corresponding standard deviation value 1110.

[0123] In FIG. 11C, the Footprint % CDF 1104 maps a footprint percentage 1114 against a footprint index 1116. In an example, the footprint index 1116 represents a percentile of patients who have a footprint percentage value equal to or less than the corresponding footprint percentage 1114.

[0124] FIG. 12 is an example of a probability distribution function chart 1200 that illustrates reference group patients' physical activity levels. The chart 1200 includes activity values on the x-axis and a percentage of patients who have the corresponding activity on the y-axis. To determine an activity index for a particular patient, the area under the probability distribution function (PDF) curve is calculated. In the example illustrated, by using equations that describe the probability distribution function chart 1200, it can be calculated that a patient with an activity level of 14 corresponds to a point 1202 on the curve. The 1-D activity PDF shown in FIG. 12 identifies a pair of points with equivalent probability density that defines an interval of integration. By analogy, a 2-D density would yield sets of points with equivalent probability densities or contours that would define areas of integration. In the example illustrated in FIG. 12, point 1202 and point 1204 share a common probability density. Using the two points 1202, 1204, an area 1206 under the PDF is defined. In an example, the activity index is equal to the area 1206 under the PDF. Using the calculated activity index may provide advantages, including easier comparison between several patients or easier communication of a patient status to the patient or other medical professionals.

Inter-Relationship Between within Patient Diagnosis and Between-Patient Diagnosis

[0125] A between-patient analysis may provide a more long-term indication of a patient's risk compared to a population. In contrast, a within-patient analysis may provide a more short-term indication of acute changes in a patient's health. Thus, it may be advantageous to use one analysis to tune performance of another analysis. For example, a between-patient analysis that includes a large number of patients in the population may provide a sufficient confidence that a particular patient is high or low risk for the

occurrence of a particular physiological condition. If the patient is considered high-risk, then one or more parameters of a within-patient analysis may be modified. For example, sampling timing intervals may be shortened to detect acute changes quicker, threshold values may be revised, or a probability distribution model may be selected based on the type or severity of the population-based risk. In contrast, if the patient is considered low-risk or lower risk, then a within-patient analysis may not be considered necessary. Alternatively, the within-patient analysis in such a situation may be revised to less be invasive or have reduced sensitivity and increased specificity (e.g., to reduce false alarms). Such a system may allow physicians to stratify patients according to their long-term risk using the between-patient technique and keep a closer watch for acute changes in patients with higher risk using the within-patient technique

[0126] In an example, a within-patient decompensation detection technique may be enabled or disabled when a low or high index value is returned from a between-patient risk stratification technique. FIG. 13 is a diagram 1300 illustrating an example of control and data flow between patient analysis processes. Sensor data 1302 is received and analyzed by a between-patient diagnostic technique 1304, such as one described above. The between-patient diagnostic technique 1304 outputs an index 1306 indicative of a risk or likelihood of a patient experiencing a disease or other health concern similar to that of the population used in the between-patient diagnostic technique 1304. A control module 1308 receives the index 1306 and compares it to a risk threshold. In an example, the risk comparison results in a tri-state output, such as "low," "medium," and "high" risk in comparison to a threshold value or a range of threshold values. When the index 1306 is associated with a low risk, then a corresponding within-patient alert (WPA) technique is disabled 1308. When the index 1306 is associated with a medium risk, then no change is made—if the WPA technique was enabled, then it remains enabled, and if the WPA technique was disabled, then it remains disabled. When the index 1306 is associated with a high risk, then the WPA technique is enabled. In an example, the WPA technique is enabled or disabled automatically. In another example, a user (e.g., an attending physician) may be notified of the suggested change in WPA state and may then manually or semi-automatically enable or disable the WPA technique.

[0127] Example: After a hospitalization, cardiac diagnostics may stabilize due to the effect of a drug therapy resulting in a lower index value (result of a between-patient diagnostic technique). In light of the lower index value, the within-patient technique may no longer be considered necessary. Thus, the within-patient technique may be disabled automatically or manually to reduce false alarms that may result from acute changes in patient data.

[0128] Example: After an implant procedure, if the index value from a between-patient technique is high enough (e.g., greater than a threshold value), it may imply that the patient is sufficiently different from a reference group comprising stable CRT-D patients that a physician may choose to maintain a closer watch on the patient. To do so, the physician may enable within-patient technique to alert the physician of acute changes in diagnostic parameters.

[0129] In an example, one or more parameters of a within-patient technique may be enabled, disabled, or modified

based on the result of a between-patient technique. For example, an acute detection threshold may be adjusted based on one or more population-based risk assessments. As another example, a measurement probability distribution function (PDF) model may be selected based on the population-based result (e.g., using a Gaussian or log normal PDF model).

[0130] FIG. 14 is a diagram 1400 illustrating an example of control and data flow between patient analysis processes. Similar to the system described in FIG. 13, based on an index value 1402, risk can be assessed with a tri-state output. In this illustration, when the risk is considered low, then one or more parameters in the within-patient technique are modified to make the technique more specific and less sensitive 1404. When the risk is considered high, then the technique is made more sensitive and less specific by adjusting the one or more parameters 1406. Finally, when the risk is considered medium, then the one or more parameters are maintained at their current values 1408. Parameters may include weights in a weighted function (weighting factors), models used for patient comparison, one or more threshold values, or the like. Parameters may also include variables that control conditional states (e.g., control flow), sample resolution (timing), frequency of assessment, pattern of assessment (e.g., time of day, sequencing of multiple assessments), or the like. For example, one or more parameters may be automatically determined or provided by a user (e.g., a physician or clinician) to indicate which of one or more analysis processes are evaluated and in which order after a preceding analysis is completed. Controlling the selection and arrangement of the analysis processing may be advantageous to refining the analytical result or reducing processing errors (e.g., false positive or false negative indications).

[0131] By automatically or manually adjusting the parameters of the within-patient technique, false alerts may be reduced or minimized, which may allow patients to be managed more efficiently. In an example, some parameters are adjusted automatically. In another example, one or more proposed changes to parameters are presented to a user, for example, an attending physician, who then may either permit or deny changes to the parameters.

[0132] Example: If a between-patient stratifier technique indicates that SDANN has a higher sensitivity for a particular patient compared to minimum heart rate (HRMin), then a within-patient technique may be modified to assign a higher weight to an SDANN parameter in a weighted function.

[0133] In certain examples, one or more performance parameters of a first technique, such as a between-patient stratifier, may be adjusted to affect the false positives, false negatives, specificity, sensitivity, positive predictive value, negative predictive value, number of false positives per year of a second technique, such as a within-patient technique.

[0134] As described above, sensitivity generally refers to the ability of the detection scheme to effectively detect a particular result. Sensitivity can be expressed with the formula: $\text{sensitivity} = (\text{true positives}) / (\text{true positives} + \text{false negatives})$. Thus, a higher sensitivity generally indicates that an analysis correctly characterizes more true positives or eliminates false negatives.

[0135] Specificity generally refers to the ability of the detection scheme to avoid improper classifications. Specificity can be expressed with the function: $\text{specificity} = (\text{true negatives}) / (\text{true negatives} + \text{false positives})$. Thus, a higher specificity generally reflects more accurate classification of true negatives or reduction of false positives.

[0136] Positive predictive value (PPV) generally refers to the ability of the detection scheme to accurately produce correct positive results. PPV can be expressed with the function: $\text{PPV} = (\text{true positive}) / (\text{true positives} + \text{false positives})$. Thus, PPV exhibits a ratio of correct positive indications.

[0137] Negative predictive value (NPV) generally refers to the ability of the detection scheme to accurately produce correct negative results. NPV can be expressed with the function: $\text{NPV} = (\text{true negatives}) / (\text{true negatives} + \text{false negatives})$. Thus, NPV exhibits a ratio of correct negative indications.

[0138] False positives (FP) per year is a ratio of false positive indications over one or more years. False positives per year can be expressed with the function: $\text{FP/yr} = (\text{FP in one or more years}) / (\text{number of years})$.

[0139] In an example, a within-patient technique may be used to influence a between-patient technique. For example, the between-patient technique may be enabled, disabled, or have one or more parameters modified or enabled based on the results of the within-patient technique.

[0140] FIG. 15 illustrates a cross-feedback configuration of patient analysis processes. Patient data 1500 is received at an analysis system 1502. In an example, the analysis system includes a remote patient management system, such as LATITUDE®. A between-patient index technique 1504 or a within-patient technique 1506 may use the received patient data 1500 to calculate an index 1508 or an alert 1510, respectively. In an example, the index 1508 indicates how similar a patient is to a patient population (e.g., reference group). In an example, the alert 1510 indicates an acute change in patient physiological parameters. The index 1508 and the alert 1510 are received at a control system 1516. In an example, the control system 1516 is part of the same system as the analysis system 1502, e.g., LATITUDE®. In other examples, the control system 1516 and the analysis system 1502 are in separate devices. For example, the analysis system 1502 may be located in a programmer, while the control system 1516 may be located at a centralized patient management server. A first module 1512 in the control system 1516 determines whether to modify the within-patient technique 1506 based on the calculated index 1508. A second module 1514 in the control system 1516 determines whether to modify the between-patient index technique 1504 based on the alert 1510. In either case, examples of the modifications may include enabling, disabling, initializing, or modifying one or more parameters of the corresponding technique.

[0141] In another example, three or more diagnostic techniques are configured to interact with each other. For example, a first between-patient diagnostic technique may be configured to focus on physical activity levels, a second between-patient index may be configured to focus on heart rate variability, and a third within-patient diagnostic technique may also be available. The results of the within-patient diagnostic technique (third technique) may affect one or both of the between-patient techniques (first and second). In other examples, two of the techniques may be configured to affect the third. In other examples, one technique may be used to determine which subsequent technique is used or in what order subsequent techniques are performed. In such a

configuration, the collection of techniques may be viewed as a state machine. Creating a matrix or “web” of one or more permutations or combinations of between-patient or within-patient diagnostic techniques may provide higher efficiency in diagnosis or fewer false positive or false negative indications.

Physician Feedback

[0142] In some situations, diagnostic techniques, such as those described herein, may result in false positive or false negative indications. For example, false indications may occur when a technique is first initialized to a general state before the technique has been revised or tuned for a particular patient. To reduce the number of false indications and improve accuracy, it may be advantageous to allow a medical professional to monitor and control such diagnostic techniques.

[0143] FIG. 16 is a dataflow diagram illustrating an example of a physician feedback process. Patient data 1600 is communicated to a control system 1602. Patient data 1600 may include physiological data, environmental data, or subjective patient responses, in various examples. In an example, the control system 1602 includes some or all of the components described in 108 (FIG. 1). In the example illustrated in FIG. 16, the control system includes a storage device 1604 and an operating device 1606. The storage device 1604 may be configured as a database, a file structure, or other storage means. The storage device 1604 typically includes a patient data file 1608, a physician data file 1610, and patient diagnostic routine file 1612.

[0144] The patient data file 1608 may include historical physiological data such as in raw or summarized format, historical subjective responsive patient data, one or more alerts generated from one or more patient detection techniques, trending data, extrapolated data (e.g., minimum, maximum, or median patient-related values for a particular timeframe), or other patient-related information (e.g., patient identification information, hospitalization information, historical automatic or physician diagnoses, etc.).

[0145] The physician data file 1610 may include physician notes or comments related to a particular patient, physician input (as described in further detail below), prescribed therapies, or other physician-related information.

[0146] Patient diagnostic routine file 1612 may include programmatic code or other structures that control or enable the decisional process of an automated patient evaluation. Patient diagnostic routine file 1612 may also include variables, such as threshold values, weighting factors, or other parameters used during the execution of patient diagnostic routines.

[0147] The operating device 1606 may include one or more computers or other programming devices to control the execution of patient diagnostic routines 1614. In an example, the operating device 1606 may access patient data from the patient data repository 1608, initialize one or more patient diagnostic routines 1614 using parameters stored in the patient data file 1608 or the patient diagnostic routine file 1612, execute the patient diagnostic routines 1614, and store results in the patient data file 1610 or the patient diagnostic routine file 1612.

[0148] At some time, a physician or other medical professional may access the control system 1602 and receive patient-related data 1616. Patient-related data 1616 may include physiological data, test results, summary data,

patient diagnostic parameters, patient therapies, or other patient data stored in the patient data file 1608 or the patient diagnostic routine file 1612. The physician may have an opportunity to interview or examine the patient, such as during a patient visit 1618. Using the observation, interview, or other information, the physician may provide feedback 1620 to the control system 1602. In an example, the physician may provide physician input (e.g., feedback 1620) to the control system 1602 using an observation, interview, examination, or evaluation of a patient or patient-related data. Such input may be independent from a contemporaneous result generated at the control system 1602, such that the physician may not have reviewed test results or may not have been provided with test results in the patient-related data 1616. An independent evaluation of a patient, not biased by a result generated by the control system 1602, may advantageously provide a “gold standard” or truth standard, by which the control system 1602 may adapt its methods or processes to be more accurate when compared to the physician’s assessment.

[0149] In some examples, a physician or clinician may provide input or feedback using a terminal, for example as illustrated at 112 (FIG. 1). In some examples, a physician or clinician may provide input to an electronic medical records system 1622. Some or all of an electronic medical record 1624 (EMR) stored at the electronic medical records system 1622 may then be imported to control system 1602. Portions or all of physician feedback 1620 may be stored in the physician data file 1610. In an example, the operating device 1606 may use physician feedback 1620 to alter or adjust the execution of one or more patient diagnostic routines 1614.

[0150] FIG. 17 illustrates an example of a feedback loop between a central system and a physician. At some time, patient data is received 1700. The patient data is analyzed 1702 by one or more patient diagnostic routines. Results of the analysis are stored 1704. A physician or clinician may access and review 1706 the stored results. The physician or clinician may provide feedback 1708. The feedback may be in the form of a verification (e.g., correct or incorrect result) or one or more commands (e.g., increase specificity or decrease threshold of a particular patient diagnostic routine), in various examples. The feedback may be an independent assessment of a patient in an example. In examples, the feedback message may be in the form of one or more standardized languages (e.g., eXtensible Markup Language (XML)) or in a standardized format (e.g., comma-separated file (.csv)). Using the physician or clinician’s feedback, one or more parameters of the analysis are modified 1710, which may affect later execution.

[0151] FIG. 18 is a flowchart illustrating an example of a method 1800 of using physician feedback to modify the execution of patient analysis routines. At 1802, patient data is received. Patient data may originate from one or more sources, including sensed physiological data from one or more implanted or external monitoring devices, patient response data from an interactive or interrogatory device, or health data obtained during an office visit or other examination or interview with a medical professional. Patient data may also be retrieved or received from an external data source, such as an electronic medical records database.

[0152] At 1804, the patient data is analyzed with one or more patient diagnostic analyses, such as those described above (e.g., within-patient technique or between-patient technique). At 1806, the results of the analysis are provided

to a user. In an example, the results are automatically forwarded to a user when certain conditions exist, for example, when an alert has been generated. In another example, the results are stored for later access by a user.

[0153] At 1808, a response is received from the user. The response may include a verification message in an example. The verification message may indicate that the results of the analysis were correct or incorrect based on further investigation by the user, for example. In another example, the response may include one or more user directives. The user directive may occur alone or in combination with a verification message. User directives may include increasing or decreasing an analysis' sensitivity or specificity; raising, lowering, or providing a particular value for a threshold or other parameter; or increasing, decreasing, or providing a particular value for an importance or ranking of a sensor or measurement. Further examples of user directives are described below.

[0154] At 1810, one or more aspects of patient diagnostic analyses are modified or adjusted using the response. Modifications may include enabling or disabling an analysis, increasing or decreasing one or more weights in a weighted function associated with an analysis, or modifying an alert detection technique (e.g., by raising or lowering a threshold). Other modifications may be implemented, such as choosing one predictive or discrimination technique over another or choosing which techniques to use together. For example, in the context of tachyarrhythmia discrimination and detection, a physician may decide to use a morphology-based discrimination algorithm (e.g., Rhythm ID) over an interval-based discrimination algorithm (e.g., one-button detection enhancement (OBDE)). As another example, in the context of heart failure decompensation detection or prediction, a physician may choose to blend the results of a pulmonary edema detection with an electrical dyssynchrony detection.

[0155] FIG. 19 is an example of a user-interface to allow a medical professional to submit input or feedback to a control system. In the example illustrated, a medical professional may provide an indication of whether a heart failure patient is decompensating. Such an indication is provided independent from any result calculated from the control system. For example, a physician may independently examine or interview a patient and derive a diagnosis without referring to a diagnosis generated by the control system. The indication need not be tied to a particular diagnostic analysis. For example, the physician may provide an indication that may be related to one or more within-patient diagnostic techniques and/or one or more between-patient diagnostic techniques. In various examples, the medical professional may be presented an input to provide one or more health characterizations (e.g., aspects of decompensation, arrhythmia, weight gain, blood pressure), some of which may be used by the control system (e.g., 1602 in FIG. 16) to modify a parameter or other aspect of a patient diagnostic technique, or a sensor's detection process.

[0156] FIG. 20 is a control flow diagram illustrating an example of an interaction between a user-interface system 2002 and a control system 2004 in accordance with the user-interface illustrated in FIG. 19. In an example, the user-interface system 2002 is incorporated into a user terminal, such as illustrated in FIG. 1 at 112. In an example, the control system 2004 is incorporated into a remote server system, such as 108 in FIG. 1. In the example illustrated in

FIG. 20, data 2006 is received by the control system 2004 and analyzed by a within-patient analysis 2008, such as an analysis described herein. A composite alert score is evaluated and compared to a threshold value (Th). If the composite alert score is greater than the threshold (Th), then the status is presented to a physician interface 2010, such as for display. In examples, the physician interface 2010 may include a computer terminal, an electronic medical records system, or other input mechanism. A physician may make an independent determination of the patient's status, for example during an office visit or during a telephonic patient interview. The physician may then provide the independent determination using the interface, such as an interface illustrated in FIG. 19. The independent determination may be performed asynchronously with contemporaneous evaluations performed by the control system 2004 or other systems, such that, for example, the independent determination may occur before, during, or after a particular within-patient analysis 2008 has been evaluated. The independent evaluation may rely on, at least in part, data similar to that received by the control system 2004, such as data 2006, or may use independently obtained data, such as data obtained during a patient examination, or may use a combination of data sources. Whatever the source of data, the independent evaluation is typically made without reference to automatically determined results, such as results of within-patient analysis 2008. In an example, the independent evaluation is stored at an electronic medical records store and later communicated to the control system 2004 in the form of an assessment message.

[0157] The independent determination may take the form of an assessment message 2012. One or more assessment messages 2012 are communicated to a verification module 2014 in the control system 2004. In various examples, the assessment message 2012 may be formatted using a standardized interface language, such as XML, or in a standard file format, such as comma-separated values (csv) or a tab delimited format. The verification module 2014 also has access to or is provided one or more aspects of the analysis 2008, such as current threshold values, current sensors used, or current CAS value. The verification module 2014 may include one or more programmatic modules, such as software programs, to compare the physician's assessment message 2012 with the output of the analysis 2008. For example, when the physician indicates that the patient is decompensating, if the results of the analysis 2008 indicate that the patient is more likely to decompensate, then the verification module 2014 generates a verification message 2016 indicating that the result of the analysis was correct. In various examples, the verification message 2016 may be formatted using a standardized interface language, such as XML, or in a standard file format, such as comma-separated values (csv) or a tab delimited format. However, if the physician indicates that the patient is not decompensating, then the verification module 2014 generates a verification message 2018 indicating that the result of the analysis was incorrect.

[0158] The verification message 2016, 2018 is received by a control message module 2020. The control message module 2020 also has access to or is provided with one or more aspects of the analysis 2008. The control message module 2020 may include one or more programmatic units, such as software, hardware, or a combination of both, containing instructions to determine what type of modification if any, is communicated to the analysis 2008. For example, when the

within-patient analysis **2008** indicated an alert state and the verification message **2018** indicates that the result was incorrect, then in an example, the control message module **2020** generates a control message **2022** to reduce the sensitivity of the analysis and the control system **2004** may then increase the threshold value **2014** to make the analysis **2008** more specific in later evaluations. By increasing the threshold value and making the analysis more specific, the physician may affect the analysis to reduce false positives in later evaluations. In certain examples, the control message module **2020** may have access to or be provided with one or more parameters that influence which control message is generated in a particular situation. For example, if an analysis is incorrect and the threshold value has been increased several times, then the control message module **2020** may generate a control message **2024** indicating to maintain the current threshold value.

[**0159**] In a similar fashion, if the composite alert score does not exceed the threshold, then that result may also be presented to the physician interface **2010**. The physician may make a similar independent evaluation of the patient's status and submit an assessment message **2012** to the verification module **2014** in the control system **2004**. The verification module **2014** then compares the physician's independent evaluation, contained in the assessment message **2012** with one or more aspects of the result of the analysis and generates a verification message **2026**. The verification message **2026** is then communicated to the control message module **2020** and a control message **2028**, **2030** is generated. The control system **2004** may use the control message **2028**, **2030** to decrease the threshold **2032** or keep the same threshold **2034**, in certain examples. For example, if the physician indicates that the patient is not decompensating, then the verification module **2014** confirms that the physician's diagnosis is consistent with the result of the analysis **2008** and no change is made **2034** to the threshold value. However, if the physician determines that the patient is decompensating, then the verification module **2014** may communicate a verification message **2026** indicating that the analysis was incorrect and the threshold value may be decreased **2032** to increase the sensitivity of the analysis in later evaluations. By increasing the threshold value and making analysis more sensitive, the physician may affect the analysis to reduce false negatives in later evaluations. As with previously described case, the control message module **2020** may determine that decreasing the threshold is either impossible (e.g., due to a lower limit of an analytical technique or a sensor's particular capabilities) or impracticable, and in such a case, the control message module **2020** may generate a "No Change" message **2030**.

[**0160**] FIG. **21** is an example of a user-interface to allow a medical professional to submit input or feedback to a control system. In the example illustrated, a medical professional may provide an indication of whether a particular result of a diagnostic analysis is correct. In an example, a user is provided with the results of a particular analysis (e.g., heart failure decompensation risk) along with one or more patient physiological indications (e.g., heart rate intervals, implantable electrograms, electrogram templates for tachyarrhythmia detection or rhythm discrimination, pressure (e.g., intracardiac or systemic pressure), oxygen saturation, physical activity, heart rate variability, heart sounds, thoracic or intracardiac or other impedance, respiration, intrinsic depolarization amplitude, heart rate, data related to tachyar-

rhythmia episodes, hemodynamic stability, therapy history, autonomic balance, heart rate variability trends or templates, or trends, templates, or abstractions derived from sensed physiological data). The user may then evaluate the patient's condition and determine whether the results of the analysis are correct. Conceptually, in an example, the user takes the place of the verification module **2014** in FIG. **20**.

[**0161**] FIG. **22** is a control flow diagram illustrating an example of an interaction between a user-interface system **2202** and a control system **2204** in accordance with the user-interface illustrated in FIG. **21**. In an example, the user-interface system **2202** is incorporated into a user terminal, such as illustrated in FIG. **1** at **112**. In an example, the control system **2204** is incorporated into a remote server system, such as **108** in FIG. **1**. In the example illustrated in FIG. **22**, data **2206** is received by the control system **2204** and analyzed by a within-patient analysis **2208**, such as within-patient analysis described herein. A composite alert score is evaluated and compared to a threshold value (Th). If the composite alert score is greater than the threshold (Th), then the status is presented to a physician interface **2210**, such as for display. In examples, the physician interface **2210** may include a computer terminal, an electronic medical records system, or other input mechanism. A physician may use the provided information to confirm the results of the analysis. Unlike the situation illustrated in FIG. **20**, the physician has foreknowledge of a result of the automated analysis, such that a patient evaluation is performed in response to the result and furthermore, to confirm the result. The physician may then provide the confirmation determination using the interface, such as an interface illustrated in FIG. **21**. The physician's determination is communicated using a verification message **2212** in certain examples. In various examples, the verification message **2012** may be formatted using a standardized interface language, such as XML, or in a standard file format, such as comma-separated values (csv) or a tab delimited format. Similar to the operation illustrated in FIG. **20**, the control system **2204** can use the verification message **2212** to generate one or more control messages **2214**, which may direct the control system **2204** to modify the execution of the analysis **2208**.

[**0162**] FIG. **23** is another example of a user-interface **2300** to allow a medical professional to submit feedback to a control system. In FIG. **23**, the physician is provided controls **2302**, **2304**, **2306** to adjust the sensitivity of a patient analysis. When a physician activates one of the controls **2302**, **2304**, **2306**, a control message is generated and communicated to the control system, in an example. The user-interface may be accessed, for example, during a patient evaluation where a physician has made an independent determination of the patient's status. If the physician concurs with the automatic patient analysis, then the physician may activate the "No Change" control **2306**. If the physician believes that the patient analysis is incorrect and indicating a false positive, then the physician may decide to reduce the sensitivity of the analysis and activate the "Less Sensitive" control **2302**. On the other hand, if the physician believes that the patient analysis is incorrect and indicating a false negative, then the physician may wish to increase the sensitivity of the analysis and active the "More Sensitive" control **2304**. In other examples where multiple patient analysis techniques are used, a separate set of controls may be associated with each patient analysis technique and

presented to the physician. In such a configuration, the physician may then have control over each analysis. In other examples, a single set of controls, such as those illustrated, are presented and may control multiple patient analysis techniques in an aggregate configuration. In addition, while controls that may be used to modify an algorithms sensitivity are illustrated in FIG. 23, in other examples, other controls may be provided to a user to control aspects of performance measures such as a false positive rate, a positive predictive value, a negative predictive value, or the like.

[0163] FIG. 24 is a control flow diagram illustrating an example of an interaction between a user-interface system 2402 and a control system 2404 in accordance with the user-interface illustrated in FIG. 23. Based on the result of the within-patient analysis 2406, the physician may determine that the result is incorrect and lower the sensitivity 2408 or raise the sensitivity 2410, depending on whether the incorrect result is perceived as a false positive or false negative, respectively. If the physician agrees with the within-patient analysis, then no change is indicated, such as in control messages 2412 and 2414. Control messages 2412, 2414 may be formatted using a standardized interface language, such as XML, or in a standard file format, such as comma-separated values (csv) or a tab delimited format.

[0164] FIG. 25 is another example of a user-interface 2500. In FIG. 25, a user is provided one or more controls 2504 to activate or deactivate one or more sensors associated with a patient analysis technique. In the example illustrated, one or more sensors are associated with a heart failure decompensation evaluation. A user (e.g., a physician or clinician) may use the controls 2504 to manage whether each sensor result is used in the patient analysis (e.g., within-patient analysis). Controlling such aspects of the patient evaluation may be advantageous for physicians that wish to dismiss particularly unfavorable sensors or emphasize particularly favorable sensors for a particular patient. For example, a physician may have determined during their practice that a particular sensor is less determinative or less accurate when used in a particular patient's evaluation. Using controls illustrated in FIG. 25 would allow such a physician to remove such a sensor from the calculus of such a patient's status.

[0165] Additionally, the importance, or weight, of each sensor may be provided by the user by manipulating the importance controls 2502. The importance controls 2502 may be presented as a dropdown control containing the allowable range of values indicative of importance. In an example, each sensor may be associated with a default control, which may be indicated in the importance control 2502.

[0166] FIG. 26 is a control flow diagram illustrating an example of an interaction between a user-interface system 2602 and a control system 2604 in accordance with the user-interface illustrated in FIG. 25. The user may send one or more control messages 2606A, 2606B to change sensor weights or activate or deactivate particular sensors associated with a patient analysis.

[0167] FIG. 27 is another example of a user-interface 2700 to control one or more sensors. For example, one or more controls may be provided to modify threshold values, modify sensitivity using general labels (e.g., "More Sensitive" or "Less Sensitive"), change the type of threshold computation used (e.g., an absolute value or a percent change from a baseline), or change a detection technique

used by a particular sensor. In the example illustrated in FIG. 27, threshold controls 2702 are provided to a user to set threshold values, such as a function of a percent change from a particular value (e.g., a baseline value or an arbitrary initial value). In addition, sensitivity controls 2704 are provided so that a user may generally set a particular sensor to be more or less sensitive. The sensitivity controls 2704 may be configured to indicate a current setting to the user, such as using bold face, coloring, or other graphical or textual details that display to the user the current setting. In the example shown, when a user changes a threshold value to be higher than the current setting, thus decreasing the sensitivity, the general sensitivity control 2704 associated with the changed threshold control 2702 has its presentation altered to reflect the reduced sensitivity. Similarly, when a user selects a general sensitivity control 2704, a corresponding threshold value may be indicated in the associated threshold control 2702.

[0168] FIG. 28 is a control flow diagram illustrating an example of an interaction between a user-interface system 2802 and a control system 2804 in accordance with the user-interface illustrated in FIG. 27. The user of the user-interface system 2802 may send one or more control messages 2806 to the control system 2804 to change one or more threshold values associated with one or more sensors, change the sensitivity of one or more sensors, manage the detection techniques used on one or more sensors, or perform other management tasks as described with regard to the user-interface in FIG. 27. In an example, the control system 2804 may receive unmodified, sensed data 2808 from one or more sensors 2810. The control system 2804 may then analyze the data 2808 and set one or more alerts using the modified threshold values, sensitivity levels, or other user-provided inputs, and ultimately derive the composite alert score. In other words, the control system 2804 may retain the user-provided information and manage the alerts local to the control system 2804. In another example, the control system 2804 may communicate the threshold values, sensitivity levels, or other user-provided information to one or more sensors 2810 corresponding to the sensors presented in a user-interface, such as in FIG. 27. In such an example, each sensor 2810 may then modify its own internal detection algorithm and provide appropriate alerts using the new threshold values, for example.

[0169] Some of all of the user-interfaces described in FIGS. 19, 21, 23, 25, 27 may be combined in various combinations or permutations to grant differing scopes of control to a user. Additionally, other user-interfaces not illustrated may be provided to a user to control other aspects of patient analysis techniques, such as analysis blending, sensor blending, timing intervals of sensor fusion over time, sensor settings, detection thresholds, selected population groups, or the like.

[0170] As described previously herein, centralized data may be advantageous for several reasons. For example, physicians may be able to share data easier in the situation where patients see several health care providers who are not members of the same medical practice and thus, does not have access to each other's EMR database. In addition, centralized data may provide greater insight into patient health trends when using systems and methods as described herein.

Within Patient Risk Stratification

[0171] Risk stratification of the patient can also be made using within-patient data, such as when between-patient data is unavailable or a clinician chooses not to use the between-patient data. The risk stratification can be used to adjust prediction of events by an I MB or a remote patient management system. This may reduce false alarms when detecting worsening HF status of the subject.

[0172] FIG. 29 is a flow diagram of an example of a method 2900 of operating a medical device to detect the onset of a physiological event such as an event related to heart failure. At block 2905, at least one first physiological parameter of a patient or subject is measured using a physiological sensor of an ambulatory medical device. In some examples, the physiological sensor includes a heart sound sensor and the first physiological parameter includes the measured amplitude of the S3 heart sound. Other examples of the first physiological parameter are provided herein.

[0173] At block 2910, a HF risk score is determined for the subject according to the measured at least one first physiological parameter. The HF risk score for the subject indicates susceptibility of the subject experiencing a WHF event. For example, determining a HF risk score can include assigning a HF risk score of low, medium or high based on the amplitude of the S3 heart sound exceeding a medium amplitude threshold or a high amplitude threshold. The HF risk score can be determined as a numerical value. In certain examples, the HF risk score can be determined as a value within a continuous range of values, such as a probability value calculated within a continuous range of values between zero and one.

[0174] At block 2915, at least one second physiological parameter of the subject is measured with the same or different physiological sensor. If a different physiological sensor is used, this sensor may be included in the same ambulatory medical device, a different ambulatory medical device, or a separate device that communicates with an ambulatory medical device. The at least one second physiological parameter is distinct from the at least one first physiological parameter. For example, the second physiological parameter may be a device-detected change in transthoracic impedance of the subject or device-detected weight gain of the subject that may indicate a buildup of thoracic fluid.

[0175] At block 2920, the medical device generates an indication of prediction that the subject will experience a WHF event when the at least one second physiological parameter satisfies a device-based WHF detection algorithm. The WHF detection algorithm may include detecting WHF when the second physiological parameter satisfies a WHF detection threshold such as transthoracic impedance decreasing below a threshold impedance value or a weight gain of the subject exceeding a threshold weight gain change in a specified period. Other examples of a WHF detection algorithm include, but are not limited to, a neural network algorithm, a fuzzy logic algorithm, a linear regression model algorithm, a decision tree algorithm, a Hidden Markov Model algorithm, a k-nearest neighbor algorithm, and a support vector machine.

[0176] At block 2925, prediction by the WHF detection algorithm is adjusted according to the determined HF risk score. For example, detection thresholds may be adjusted to be more easily satisfied in order to increase the sensitivity of

HF detection. In another example, neural network detection rules may be adjusted such as by weighting rules differently to make the neural network algorithm more sensitive to HF detection.

[0177] At block 2930, an indication of a predicted WHF event is generated when predicting the HF event using the adjusted WHF detection algorithm. The indication may be provided to at least one of a user or process. For example, the indication may be communicated from an implantable device to a second device for display to a user, or the indication may be communicated to process executing on a remote server that is part of a remote patient management system.

[0178] FIG. 30 is a block diagram showing portions of a system 3000 that detects the onset of a physiological event such as an event related to heart failure. The system 3000 includes a risk analysis module 3005 and a WHF detection module 3010. The modules can include hardware, software, firmware or combinations thereof to perform the functions described. The modules can include a processor, such as a microprocessor, ASIC, or other type of processor to execute the software and firmware.

[0179] The risk analysis module 3005 can be configured (e.g., by programming or logic) to measure at least one first physiological parameter of a subject using a physiological sensor of an ambulatory medical device and determine a HF risk score for the subject according to the at least one measured first physiological parameter. The HF risk score indicates susceptibility of the subject to experiencing a HF event. The HF risk score may reflect the susceptibility of the patient over six months to a year. A longer term HF risk score can result in health care resources being better allocated over the longer term.

[0180] The first physiological parameter can be measured using an electrical signal produced by the physiological sensor. According to some examples, the system 3000 includes the physiological sensor 3015.

[0181] As explained previously herein, the physiological sensor 3015 of the ambulatory medical device can include a heart sound sensor that provides a signal representative of one or more heart sounds of a patient. Some examples of a heart sound sensor include an accelerometer or microphone. The first physiological parameter can be related to the S3 heart sound and can include the measured amplitude of the S3 heart sound or energy of the S3 heart sound.

[0182] Amplitude or energy of the S3 heart sound can be measured by arranging a measurement window relative to a fiducial feature detected in a cardiac cycle. Signal processing is performed on a segment of a heart sound signal defined by the measurement window to determine S3 amplitude. For instance, the fiducial feature can be an S2 heart sound and the window is located a specified time duration (e.g., from 130 milliseconds (ms) to 270 ms) after the S2 heart sound. In another example, the fiducial feature can be the S1 heart sound and the measurement window can be located a specified time duration (e.g., 400 ms to 550 ms) after the S1 heart sound. In yet another example, the fiducial feature is the S3 heart sound and the measurement window can be positioned a specified time duration (e.g., +125 ms to -125 ms) around the S3 heart sound. In yet another example, the fiducial feature can be an R-wave or Q-wave of a QRS complex, and the measurement window can be arranged a specified time duration (e.g., 550 ms to 700 ms) after the

R-wave or Q-wave or a specified time duration (e.g., 50 ms to 150 ms) before the R-wave or Q-wave.

[0183] The S3 amplitude or energy can also be measured using a measurement window that is arranged relative two or more fiducial features in one or more cardiac cycles. For instance, a measurement window can be positioned relative to an S2 heart sound in a first cardiac cycle and an R-wave or Q-wave detected in the following cardiac cycle. In another example, a measurement window can be positioned relative to the S2 heart sound in a first cardiac cycle and the S1 heart sound in the following cardiac cycle.

[0184] The S3 amplitude measurement may represent peak amplitude of the S3 heart sound, peak-to-peak amplitude, mean amplitude, median amplitude, root-mean-squared amplitude, quantile measurement of amplitude, or other similar measurement of S3 energy. An increase in the amplitude of the S3 heart sound may indicate an increased risk of the subject experiencing an HF event (e.g., cardiac decompensation). Other parameters include the measured energy of the S3 heart sound, the measured power in the S3 heart sound, and the measured time duration of the S3 heart sound. Further examples include a time interval between two fiducial features indicative of heart sounds, such as the time interval between the S1 heart sound and the S2 heart sound. A measured decrease in the S1 to S2 time duration may indicate an increased risk of the subject experiencing a WHF event.

[0185] In some examples, the physiological sensor **3015** can include a respiration sensor that provides a signal representative of respiration of the subject. Some examples of a respiration sensor include an accelerometer to detect motion from respiration, or a circuit to measure impedance across a thorax region of the subject that varies with respiration. The first physiological parameter can include the measured respiration rate of the subject or the measured day-to-day variation in respiratory rate of the subject. An increase in respiratory rate or an increase in variation in respiration rate may indicate an increased risk of the subject experiencing a WHF event.

[0186] In some examples, the physiological sensor **3015** can include a cardiac signal sensing circuit that produces a signal representative of electrical cardiac activity of the subject. The first physiological parameter can include a time interval measured between two fiducial features occurring in one or more cardiac cycles. In some examples, the physiological sensor **3015** can include both a cardiac signal sensing circuit and a heart sound sensor, and the first physiological parameter includes one or more of the time duration between an R-wave to a fiducial of an S1 heart sound, the time duration between a Q-wave to a fiducial of the S1 heart sound, the time duration between a Q-wave to a fiducial of the S2 heart sound, the time duration between a Q-wave to a fiducial indicative of the opening of the aortic valve (Ao), the time duration between an R-wave to a fiducial indicative of Ao, and the time duration between a fiducial indicative of Ao to a fiducial indicative of closing of the aortic valve (Ac), and the time interval between the S2 heart sound and a Q-wave in the following cardiac cycle (Q-S1 time duration). A measured increase in the Q-S1 time duration may indicate an increased risk of the subject experiencing a WHF event.

[0187] In some examples, the physiological sensor **3015** can include a biomarker sensor that generates an indication of a biomarker or a surrogate indication of a biomarker that

is indicative of an HF event. In some examples, the biomarker sensor is indicative of a detected level of brain natriuretic peptide or BNP. BNP is secreted by a ventricle of the heart in response to excessive stretching of the myocardium due to HF. In some examples, the biomarker sensor is indicative of a detected level of an N-terminal amino acid secreted with BNP (NT-Pro-BNP). An indication of an increase in the level or an indication that the level exceeds a threshold level may indicate an increased risk of the subject experiencing a WHF event.

[0188] In some examples, the physiological sensor **3015** can include an impedance measurement circuit configured to measure impedance between electrodes that are positioned or can be positioned in a thorax region of the subject. The first physiological parameter can include a measurement representative of thoracic congestion. A measured decrease in thoracic impedance may indicate an increase in thoracic congestion and an increased risk of the subject experiencing a WHF event. In some examples, the electrodes are positioned or can be positioned at a large vein (e.g., the jugular vein) of the subject. The first physiological parameter can include a measurement representative of distention of the large vein (e.g., jugular vein distention or JVD). For instance, a measured decrease in the impedance between the positioned electrodes may indicate an increase in the distention of the vein that may in turn indicate an increased risk of the subject experiencing a WHF event.

[0189] The system **3000** can include the ambulatory medical device and a separate device (e.g., a device programmer or remote monitor). The risk analysis module **3005** can be included in the external device and one or both of the physiological sensor **3015** and the WHF detection module **3010** can be included in the ambulatory medical device. The ambulatory medical device may measure at least first physiologic parameter and communicate the measurement to the external device. Other arrangements are possible. For instance, an implantable device may communicate data (e.g., signal data) to an external device and at least one physiological parameter can be extracted from the communicated data. In another example, the risk analysis module **3005** is included in the ambulatory medical device. In some examples, the system **3000** includes a combination of a plurality of physiological sensors and the physiological sensors can be included in one more of the ambulatory medical devices and the separate device.

[0190] Historical data can also be used to calculate the HF risk score. In some examples, the ambulatory medical device includes a counter circuit and a timer circuit. The first physiological parameter can include a number of WHF events detected for the subject within a specified time window (e.g., one to three months). The risk analysis module **3005** may determine the HF risk score using the number of detected WHF events as the first physiological parameter.

[0191] The risk analysis module **3005** may determine a HF risk score by comparing the measured first physiological parameter with a pre-specified (e.g., programmed) threshold parameter value or a range of threshold parameter values. For instance, the risk analysis module **3005** may determine a HF risk score from one physiological parameter, or the risk analysis module may determine a HF risk score using two or more physiological parameters. In some examples, the individual risk scores can be determined for each of the plurality of physiological parameters and the individually determined

HF risk scores can then be combined to form a composite HF risk score for the subject. In some examples, the plurality of measured physiological parameters is combined directly to determine the HF risk score for the subject, such as by using a logistic regression model for example.

[0192] The risk analysis module 3005 may determine a HF risk score that categorizes the subject as low risk, medium risk, or high risk of an HF event according to the first physiological parameter. Other numbers of categories can be used, such as quartiles, deciles, quintiles, etc. The HF risk score may be the measured data of the first physiological parameter and the risk analysis module 3005 compares the determined HF risk score with at least one risk score threshold or risk score range. The risk analysis module 3005 assigns a HF risk category to the subject according to the comparison. In some examples, risk analysis module 3005 does not assign discrete risk categories as a score but uses a continuous value for the HF risk score. For instance, the risk analysis module 3005 may calculate a continuous value such as a probability value determined from the measured first parameter.

[0193] The HF risk score is used to adjust detection of a WHF event by the WHF detection module 3010. The WHF detection module 3010 measures at least one second physiological parameter of the subject using the same or different physiological sensor. If a different physiological sensor is used, the physiological sensor may reside in a different ambulatory medical device or a second device able to communicate with an ambulatory medical device. The second physiological parameter may be distinct from the first physiological parameter. For instance, the first physiological parameter may be a measurement (e.g., amplitude) of the S3 heart sound and the second physiological parameter may be a measure of deviation of the ST segment of the QRST complex of a cardiac cycle. Other examples of the second physiological parameter include blood pressure, heart rate, respiration rate, lung tidal volume, intrathoracic impedance, physical activity level, subject weight, heart sound timing, and heart sound amplitude. Still more examples of the second physiological parameter include one or more of the physiological parameters collected during a specific time of day, when the subject is in a specific posture, during a time when the subject is in a specific level of activity, or any combination of time of day, posture, and activity level.

[0194] The WHF detection module 3010 generates an indication of prediction that the subject will experience an HF event when the at least one second physiological parameter satisfies a WHF detection algorithm. The risk analysis module 3005 adjusts generation of the indication by the WHF detection algorithm according to a determined HF risk score. For instance, the WHF detection algorithm may include predicting a WHF event when the second physiological parameter satisfies a detection threshold criterion of the WHF detection algorithm. The risk analysis module 3005 may adjust the detection threshold criterion to make the detection more sensitive or less sensitive to detection according to the determined HF risk score. If the detection threshold criterion includes determining when the measured value of the second physiological parameter satisfies a specified (e.g., programmed) threshold parameter value, the risk analysis module 3005 may raise or lower the threshold value according to the HF risk score. The WHF detection module 3010 generates the indication using the adjusted

WHF detection algorithm and can provide the indication to at least one of a user or process as described previously herein.

[0195] In an illustrative example, the first physiological parameter may be the amplitude of the S3 heart sound and the second physiological parameter may be fluid status of the subject that is derived from intrathoracic impedance. Decreasing intrathoracic impedance may indicate fluid retention. Based on the measured S3 amplitude, the risk analysis module 3005 may assign a higher risk to the subject. The risk analysis module 3005 may then lower the value of an intrathoracic impedance threshold used by the WHF detection module 3010 to increase the sensitivity of prediction of a WHF event. If the risk analysis module 3005 does not identify an S3 heart sound in the heart sound signal, the risk analysis module 3005 may raise the value of an intrathoracic impedance threshold used by the WHF detection module 3010 to decrease the sensitivity of prediction of an HF event.

[0196] In another illustrative example, a combination of S3 energy and respiration rate are used as the first physiological parameters, and edema related fluid status is used as the second physiological parameter. It should be noted that both respiration rate and fluid status can be measured using intrathoracic impedance. The fluid status is measured using a component of the intrathoracic impedance that varies very slowly in frequency and is substantially DC. The respiration of the subject is measured using a component of the intrathoracic impedance that varies with a frequency of roughly one Hertz. Thus, the fluid status and the respiration rate can both be monitored using an intrathoracic impedance sensing circuit, yet the physiological parameters are distinct from each other. Based on the measured first parameters physiological parameters of S3 amplitude and respiration rate, the risk analysis module 3005 calculates a HF risk score or HF risk index for the subject and adjusts the sensitivity of prediction of a WHF event by the WHF detection module 3010 accordingly.

[0197] The functions performed by the risk analysis module 3005 and the WHF detection module 3010 can be performed by one device or can be performed by multiple devices. For instance, both the risk analysis module 3005 and the WHF detection module 3010 may both be included in an ambulatory medical device. In another example, the ambulatory medical device includes the WHF detection module 3010, and an external medical device includes the risk analysis module 3005 and a communication module in electrical communication with the risk analysis module 3005. The communication module is configured to communicate information (e.g., wirelessly) with the ambulatory medical device. The risk analysis module 3005 communicates an adjustment to the WHF detection algorithm to the ambulatory medical device.

[0198] As explained previously herein, a WHF detection algorithm other than threshold detection may be used by the WHF detection module 3010 to predict a WHF event. If the WHF detection algorithm includes a neural network algorithm, the risk analysis module 3005 may adjust a coefficient or path through a neural network decision scheme according to the determined HF risk score. If the WHF detection algorithm includes a fuzzy logic algorithm, the risk analysis module 3005 may adjust a shape of a membership function or coefficient used in a fuzzy logic decision scheme. If the WHF detection algorithm includes a linear regression

model, the risk analysis module **3005** may adjust a variable in the linear regression model. If the WHF detection algorithm includes a decision tree algorithm, the risk analysis module **3005** may remove a branch in the decision tree or adjust a weighting to the branch of the decision tree. If the WHF detection algorithm includes a Hidden Markov Model (HMM), the risk analysis module **3005** may change a probability distribution of the HMM.

[0199] In some examples, the risk analysis module **3005** may adjust at least one parameter of the WHF detection algorithm according to a determined category of the risk. In some examples, the risk analysis module **3005** continuously varies at least one parameter of the WHF detection algorithm as a function of the at least one first physiological parameter measurement. In some examples, the risk analysis module **3005** selects a WHF detection algorithm for implementation by the WHF detection module **3010** from among a plurality of detection algorithms according to the determined HF risk score. For instance, the risk analysis module **3005** may enable a logistic regression model as the WHF detection algorithm when the HF risk score is determined to be in a first HF risk score range, and enable a neural network model as the WHF detection algorithm when the HF risk score is determined to be in a second HF risk score range.

[0200] The risk analysis module **3005** may calculate a HF risk score that is static. For instance, because the risk score may reflect the susceptibility of the patient for a longer term (e.g., six months to a year) the risk analysis module **3005** may calculate the HF risk score over a specified (e.g., programmed) period of time such as thirty to sixty days to establish a baseline value or values for the at least one first parameter value. The risk analysis module **3005** then calculates the HF risk score using the baseline data. The risk analysis module **3005** may calculate a HF risk score that is dynamic. For instance, the risk analysis module **3005** may recalculate the HF risk score every day, week, or month using historical data within a specified window (e.g., 50 days to 1 day before the time when the HF risk score is updated). The risk analysis module **3005** may recalculate the HF risk score when detecting that the parameter value or values used to calculate the HF risk score have changed from the baseline value by more than a specified change amount (e.g., more than a specified percentage change in value).

[0201] If the risk analysis module **3005** uses more than one physiological parameter to calculate the HF risk score, the measurements from the parameters can be blended to produce an overall HF risk score according to the multiple measurements. In some examples, the risk analysis module **3005** measures a plurality of physiological parameters that are distinct from the at least one second physiological parameter, and determines individual HF risk scores for each of the plurality of physiological parameters. The individual HF risk scores can be combined to form a composite HF risk score for the subject. In some examples, the individual risk scores are combined using a weighting function.

[0202] According to some examples, the system **3000** includes a scoring module **3020** that determines individual reliability scores for each of the plurality of physiological parameters. A higher reliability score is assigned to a physiological parameter having a more consistent measurement. For example, a higher reliability score will be assigned to an S3 heart sound amplitude measurement if the heart sound sensor consistently identifies and measures an S3 heart sound than if the presence of an S3 heart sound is only

intermittently identified and measured. The risk analysis module **3050** may then combine the individual HF risk scores according to the determined reliability scores to form the composite HF risk score. The composite HF risk score may be calculated by excluding parameters deemed to be unreliable. For instance, the scoring module **3020** may discard a HF risk score for an individual physiological parameter measurement when a reliability score determined for the physiological parameter measurement falls below a specified reliability score threshold value.

[0203] A physician or clinician assessment of the HF condition of the subject can also be used in determining an HF risk score. In some examples, the system **3000** includes a user interface in electrical communication with the risk analysis module **3005**. The user interface can include one or more of a keyboard, mouse, display, and touchscreen. The electrical communication allows the user interface to communicate electrical signals with the risk analysis module **3005** even though there may be intervening circuitry between the user interface and the risk analysis module **3005**. The risk analysis module **3005** can receive an indication of severity of an HF condition of the subject via the user interface and determine the HF risk score according to the first physiological parameter measurement and the received indication of severity.

[0204] The risk assessment of a subject can be viewed as a first tier in detection of WHF events. Adjusting device prediction according to device-assessed risk may provide improved prediction of WHF events in patients.

Additional Notes and Examples

[0205] Example 1 includes subject matter (such as a system) comprising A risk analysis module and a WHF detection module. The risk analysis module is configured to measure at least one first physiological parameter of a subject using a physiological sensor of an ambulatory medical device, and determine a heart failure (HF) risk score for the subject according to the at least one measured first physiological parameter, wherein the HF risk score indicates susceptibility of the subject to experiencing a worsening heart failure (WHF) event. The WHF detection module is configured to measure at least one second physiological parameter of the subject using the same or different physiological sensor, wherein the at least one second physiological parameter is distinct from the at least one first physiological parameter, and generate an indication of prediction that the subject will experience a WHF event when the at least one second physiological parameter satisfies a WHF detection algorithm. The risk analysis module is configured to adjust generation of the indication by the WHF detection algorithm according to the determined HF risk score, and the WHF detection module is configured to generate the indication using the adjusted WHF detection algorithm and providing the indication to at least one of a user or process.

[0206] In Example 2, the subject matter of Example 1 optionally includes a WHF detection module configured to generate the indication of prediction of a WHF event when the at least one second physiological parameter satisfies at least one detection criterion of the WHF detection algorithm. The risk analysis module is optionally configured to adjust the at least one detection criterion of the WHF detection algorithm according to the determined HF risk score.

[0207] In Example 3, the subject matter of one or any combination of Examples 1 and 2 optionally includes a risk

analysis module configured to continuously vary at least one parameter of the WHF detection algorithm as a function of the at least one first physiological parameter measurement.

[0208] In Example 4, the subject matter of one or any combination of Examples 1-3 optionally includes a risk analysis module configured to select a detection algorithm as the WHF detection algorithm from among a plurality of detection algorithms according to the determined HF risk score.

[0209] In Example 5, the subject matter of Example 4 optionally includes a risk analysis module configured to enable a logistic regression model as the WHF detection algorithm when the HF risk score is determined to be in a first HF risk score range, and enable a neural network model as the WHF detection algorithm when the HF risk score is determined to be in a second HF risk score range.

[0210] In Example 6, the subject matter of one or any combination of Examples 1-5 optionally includes a risk analysis module configured to compare the determined HF risk score with at least one risk score threshold, and assign a HF risk category to the subject according to the comparison.

[0211] In Example 7, the subject matter of one or any combination of Examples 1-6 optionally includes one or more ambulatory medical devices. At least one of the ambulatory medical devices optionally includes at least one of a heart sound sensor and wherein the at least one first physiological parameter includes a measured amplitude of the S3 heart sound, a respiration sensor and wherein the at least one first physiological parameter includes a measured day-to-day variation in respiratory rate of the subject, a cardiac signal sensing circuit and wherein the at least one first physiological parameter includes a time interval measured between two fiducial features occurring in one or more cardiac cycles, a biomarker sensor configured to generate an indication or a surrogate indication of a biomarker indicative of a WHF event and wherein the at least one first physiological parameter includes at least one of a direct measure or a surrogate measure of the biomarker, a jugular vein distention (JVD) sensor configured to generate an indication of JVD or a surrogate indication of JVD, and a counter circuit and a timer circuit, and wherein the at least one first physiological parameter includes a number of HF events detected for the subject within a specified time window.

[0212] In Example 8, the subject matter of one or any combination of Examples 1-7 optionally includes a risk analysis module configured to measure a plurality of physiological parameters that are distinct from the at least one second physiological parameter, and determine the HF risk score using the plurality of physiological parameters.

[0213] In Example 9, the subject matter of one or any combination of Examples 1-8 optionally includes a scoring module configured to determine individual reliability scores for each of the plurality of physiological parameters, wherein a higher reliability score is assigned to a physiological parameter having a more consistent measurement. The risk analysis module is optionally configured to combine the individual HF risk scores according to the determined reliability scores to form a composite HF risk score.

[0214] In Example 10, the subject matter of Example 9 optionally includes a scoring module configured to discard a HF risk score for a physiological parameter measurement

when a reliability score determined for the physiological parameter measurement falls below a specified reliability score threshold value.

[0215] In Example 11, the subject matter of one or any combination of Examples 1-10 optionally includes a user interface in electrical communication with the risk analysis module. The risk analysis module is optionally configured to receive an indication of severity of an HF condition of the subject via the user interface, and determine the HF risk score according to the first physiological parameter measurement and the received indication of severity.

[0216] In Example 12, the subject matter of one or any combination of Examples 1-11 optionally includes an ambulatory medical device that includes the WHF detection module and an external medical device. The external medical device optionally includes the risk analysis module and a communication module in electrical communication with the risk analysis module. The communication module is optionally configured to communicate information with the ambulatory medical device, and the risk analysis module is optionally configured to communicate an adjustment to the WHF detection algorithm to the ambulatory medical device.

[0217] Example 13, can include subject matter (such as a method, a means for performing acts, or a machine-readable medium including instructions that, when performed by the machine, cause the machine to perform acts), or can optionally be combined with the subject matter of one or any combination of Examples 1-12 to include such subject matter, comprising measuring at least one first physiological parameter of a subject using a physiological sensor of an ambulatory medical device, determining a heart failure (HF) risk score of the subject according to the measured at least one first physiological parameter (the HF risk score indicates susceptibility of the subject experiencing a worsening heart failure (WHF) event), measuring at least one second physiological parameter of the subject with the same or different physiological sensor (the at least one second physiological parameter is distinct from the at least one first physiological parameter), generating an indication of prediction that the subject will experience a WHF event when the at least one second physiological parameter satisfies a device-based WHF detection algorithm, adjusting prediction by the WHF detection algorithm according to the determined HF risk score, and generating an indication of a predicted WHF event when predicting the WHF event using the adjusted WHF detection algorithm and providing the indication to at least one of a user or process.

[0218] Such subject matter can include means for measuring at least one first physiological parameter of a subject using a physiological sensor of an ambulatory medical device, an illustrative example of which includes a risk analysis module. Such subject matter can include means for determining a heart failure (HF) risk score of the subject according to the measured at least one first physiological parameter, an illustrative example of which is a risk analysis module. Such subject matter can include means for measuring at least one second physiological parameter of the subject with the same or different physiological sensor, an illustrative example of which is a WHF detection module. Such subject matter can include means for generating an indication of prediction that the subject will experience a WHF event when the at least one second physiological parameter satisfies a device-based WHF detection algorithm, an illustrative example of which is a WHF detection

module. Such subject matter can include means for adjusting prediction by the WHF detection algorithm according to the determined HF risk score, an illustrative example of which is a risk analysis module. Such subject matter can include means for generating an indication of a predicted WHF event when predicting the WHF event using the adjusted WHF detection algorithm and providing the indication to at least one of a user or process, an illustrative example of which is a WHF detection module.

[0219] In Example 14, the subject matter of Example 13 can optionally include an WHF event predicted when the at least one second physiological parameter satisfies at least one detection criterion of the WHF detection algorithm, and adjusting the at least one second physiological parameter detection criterion of the WHF detection algorithm according to the determined HF risk score.

[0220] In Example 15, the subject matter of one or any combination of Examples 13 and 14 optionally includes varying at least one WHF detection algorithm parameter continuously as a function of the determined HF risk score.

[0221] In Example 16, the subject matter of one or any combination of Examples 13-15 optionally includes selecting a detection algorithm from a plurality of WHF detection algorithms according to the determined HF risk score.

[0222] In Example 17, the subject matter of one or any combination of Examples 13-16 optionally includes assigning a HF risk category to the subject according to a comparison of the determined HF risk score with at least one risk score threshold.

[0223] In Example 18, the first physiological parameter of one or any combination of Example 13-18 optionally includes at least one of the amplitude of the S3 heart sound, a number of HF events experienced by the subject within a specified time window, day-to-day variation of respiratory rate, a direct measure of a biomarker indicative of a WHF event, a surrogate measure of a biomarker indicative of a WHF event, a time interval between two fiducial features occurring in one or more cardiac cycles, and a measure of jugular vein distention (JVD).

[0224] In Example 19, the subject matter of one or any combination of Examples 13-18 optionally includes measuring a plurality of physiological parameters distinct from the at least one second physiological parameter, and determining the HF risk score using the plurality of physiological parameters.

[0225] In Example 20, the subject matter of one or any combination of Examples 13-19 optionally includes receiving an indication of severity of an HF condition of the subject into the ambulatory medical device via a user interface, and determining the HF risk score according to the at least one first physiological parameter measurement and the received indication of severity.

[0226] Example 21 can include, or can optionally be combined with any portion or combination of any portions of any one or more of Examples 1-20 to include, subject matter that can include means for performing any one or more of the functions of Examples 1-20, or a machine-readable medium including instructions that, when performed by a machine, cause the machine to perform any one or more of the functions of Examples 1-20.

[0227] These non-limiting examples can be combined in any permutation of combination.

[0228] The above detailed description includes references to the accompanying drawings, which form a part of the

detailed description. The drawings show, by way of illustration, specific embodiments in which the invention can be practiced. These embodiments are also referred to herein as "examples." All publications, patents, and patent documents referred to in this document are incorporated by reference herein in their entirety, as though individually incorporated by reference. In the event of inconsistent usages between this document and those documents so incorporated by reference, the usage in the incorporated reference(s) should be considered supplementary to that of this document; for irreconcilable inconsistencies, the usage in this document controls.

[0229] In this document, the terms "a" or "an" are used, as is common in patent documents, to include one or more than one, independent of any other instances or usages of "at least one" or "one or more." In this document, the term "or" is used to refer to a nonexclusive or, such that "A or B" includes "A but not B," "B but not A," and "A and B," unless otherwise indicated. In the appended claims, the terms "including" and "in which" are used as the plain-English equivalents of the respective terms "comprising" and "wherein." Also, in the following claims, the terms "including" and "comprising" are open-ended, that is, a system, device, article, or process that includes elements in addition to those listed after such a term in a claim are still deemed to fall within the scope of that claim. Moreover, in the following claims, the terms "first," "second," and "third," etc. are used merely as labels, and are not intended to impose numerical requirements on their objects.

[0230] Method examples described herein can be machine or computer-implemented at least in part. The functions or algorithms described in method examples can correspond to modules, which can be software, hardware, firmware or combinations thereof. Some examples can include a computer-readable medium or machine-readable medium encoded with instructions operable to configure an electronic device to perform methods as described in the above examples. An implementation of such methods can include code, such as microcode, assembly language code, a higher-level language code, or the like. Such code can include computer readable instructions for performing various methods. The code can form portions of computer program products. Further, the code can be tangibly stored on one or more volatile or non-volatile computer-readable media during execution or at other times. These computer-readable media can include, but are not limited to, hard disks, removable magnetic disks, removable optical disks (e.g., compact disks and digital video disks), magnetic cassettes, memory cards or sticks, random access memories (RAM's), read only memories (ROM's), and the like.

[0231] The above description is intended to be illustrative, and not restrictive. For example, the above-described examples (or one or more aspects thereof) may be used in combination with each other. Other embodiments can be used, such as by one of ordinary skill in the art upon reviewing the above description. The Abstract is provided to comply with 37 C.F.R. § 1.72(b), to allow the reader to quickly ascertain the nature of the technical disclosure. It is submitted with the understanding that it will not be used to interpret or limit the scope or meaning of the claims. Also, in the above Detailed Description, various features may be grouped together to streamline the disclosure. This should not be interpreted as intending that an unclaimed disclosed feature is essential to any claim. Rather, inventive subject

matter may lie in less than all features of a particular disclosed embodiment. Thus, the following claims are hereby incorporated into the Detailed Description, with each claim standing on its own as a separate embodiment. The scope of the invention should be determined with reference to the appended claims, along with the full scope of equivalents to which such claims are entitled.

1. A medical device system comprising:
 - a risk analysis module configured to determine a heart failure (HF) risk score for a subject using an S3 heart sound parameter of the subject; and
 - a control module configured to calculate a worsening heart failure (WHF) score for the subject using a HF parameter,
 - wherein the control module is configured to adjust calculation of the WHF score according to the determined HF risk score.
2. The medical device system of claim 1, wherein the risk analysis module is configured to determine the HF risk score for the subject using a composite risk value including the S3 heart sound parameter.
3. The medical device system of claim 1, wherein the control module, to calculate the WHF score for the subject, is configured to apply a weighting function to the HF parameter, and to adjust the weighting function using the determined HF risk score.
4. The medical device system of claim 3, wherein the control module, to calculate the WHF score for the subject, is configured to applying a weighting function to a subset of HF parameters including the HF parameter, and to adjust the weighting of values of the subset of HF parameters as a function of the determined HF risk score.
5. The medical device system of claim 4, wherein the control module is configured to determine the subset of HF parameters from a set of HF parameters using the determined HF risk score.
6. The medical device system of claim 5, wherein the set of HF parameters includes one or more of heart rate (HR), respiration rate (RR), tidal volume (TV), intrathoracic impedance (ITTI), or one or more of heart sound (HS) timing or amplitude.
7. The medical device system of claim 1, wherein the S3 heart sound parameter includes an energy or an amplitude of an S3 heart sound of the subject.
8. The medical device system of claim 1, wherein the risk analysis module, to determine the HF risk score, is configured to determine one of a high risk of HF decompensation or a low risk of HF decompensation.
9. The medical device system of claim 1, including:
 - an ambulatory medical device including the risk analysis module configured to calculate the WHF score; and
 - an external device including the control module configured to determine the HF risk score.

10. The medical device system of claim 1, including an ambulatory medical device including the risk analysis module and the control module.

11. A method of operation of a medical device system, the method comprising:

determining, using a risk analysis module, a heart failure (HF) risk score for a subject using an S3 heart sound parameter of the subject; and

calculating, using a control module, a worsening heart failure (WHF) score for the subject using a HF parameter, wherein the calculating the WHF score for the subject is adjusted according to the determined HF risk score.

12. The method of claim 11, wherein determining the HF risk score for the subject includes using a composite risk value determined using the S3 heart sound parameter.

13. The method of claim 11, wherein calculating the WHF score for the subject includes using a weighting function applied to the HF parameter, and adjusting the weighting function using the determined HF risk score.

14. The method of claim 13, wherein calculating the WHF score for the subject includes applying a weighting function to a subset of HF parameters including the HF parameter, and

wherein adjusting the weighting function includes adjusting the weighting of values of the subset of HF parameters as a function of the determined HF risk score.

15. The method of claim 14, including determining the subset of HF parameters from a set of HF parameters using the determined HF risk score.

16. The method of claim 15, wherein the set of HF parameters includes one or more of heart rate (HR), respiration rate (RR), tidal volume (TV), intrathoracic impedance (ITTI), or one or more of heart sound (HS) timing or amplitude.

17. The method of claim 11, wherein the S3 heart sound parameter includes an energy or an amplitude of an S3 heart sound of the subject.

18. The method of claim 11, wherein determining the HF risk score includes determining a high risk of HF decompensation or a low risk of HF decompensation.

19. The method of claim 11, wherein calculating the WHF score of the subject includes using an ambulatory medical device of the medical device system, and

wherein determining the HF risk score includes using an external device of the medical device system.

20. The method of claim 11, wherein calculating the WHF score of the subject and determining the HF risk score includes using an ambulatory medical device of the medical device system.

* * * * *

专利名称(译)	基于风险分层的心力衰竭检测算法		
公开(公告)号	US20180192894A1	公开(公告)日	2018-07-12
申请号	US15/911856	申请日	2018-03-05
[标]申请(专利权)人(译)	心脏起搏器股份公司		
申请(专利权)人(译)	心脏起搏器, INC.		
当前申请(专利权)人(译)	心脏起搏器, INC.		
[标]发明人	AN QI THAKUR PRAMODSINGH HIRASINGH AVERINA VIKTORIA A ZHANG YI SWEENEY ROBERT J		
发明人	AN, QI THAKUR, PRAMODSINGH HIRASINGH AVERINA, VIKTORIA A. ZHANG, YI SWEENEY, ROBERT J.		
IPC分类号	A61B5/0205 G16H50/30 G06Q10/00 A61B5/00 G06Q50/22 A61B5/02 A61B5/024 A61B5/08 A61N1/372 G16H50/20 G16H50/50		
CPC分类号	A61B5/0205 G06Q10/00 A61B5/4842 A61B5/0816 A61B5/024 A61B5/02007 G16H50/20 G06Q50/22 A61B5/0031 A61N1/37282 G16H50/50 G16H50/30 A61B5/7275 G06F19/00 G16H40/63		
外部链接	Espacenet USPTO		

摘要(译)

系统包括风险分析模块和恶化心力衰竭 (WHF) 检测模块。风险分析模块使用移动医疗设备的生理传感器测量对象的至少一个第一生理参数, 并根据至少一个测量的第一生理参数确定对象的心力衰竭 (HF) 风险分数。HF 风险评分表明受试者对经历 HF 事件的易感性。WHF 检测模块使用相同或不同的生理传感器测量对象的至少一个第二生理参数, 并且当至少一个第二生理参数满足 WHF 检测算法时, 生成对象将经历 WHF 事件的预测的指示。风险分析模块根据确定的 HF 风险分数通过 WHF 检测算法调整指示的生成。

