



US 20170312518A1

(19) **United States**

(12) **Patent Application Publication**  
**Ziegler et al.**

(10) **Pub. No.: US 2017/0312518 A1**

(43) **Pub. Date: Nov. 2, 2017**

(54) **MONTAGE DESIGN FOR CLOSED LOOP SENSING AND NEUROSTIMULATION OF THE DORSAL LATERAL PREFRONTAL CORTEX AND/OR MOTOR CORTEX**

**Publication Classification**

(71) Applicant: **HRL Laboratories, LLC**, Malibu, CA (US)

(51) **Int. Cl.**  
*A61N 1/36* (2006.01)  
*A61N 1/04* (2006.01)  
*A61N 1/04* (2006.01)  
*A61B 5/00* (2006.01)  
*A61B 5/0478* (2006.01)  
*A61N 1/20* (2006.01)  
*A61B 5/00* (2006.01)

(72) Inventors: **Matthias Ziegler**, Oakton, VA (US);  
**Jaehoon Choe**, Agoura Hills, CA (US);  
**Matthew E. Phillips**, Calabasas, CA (US)

(52) **U.S. Cl.**  
CPC ..... *A61N 1/36025* (2013.01); *A61N 1/20* (2013.01); *A61N 1/0484* (2013.01); *A61B 5/0075* (2013.01); *A61B 5/4836* (2013.01); *A61B 5/0478* (2013.01); *A61N 1/0456* (2013.01)

(21) Appl. No.: **15/148,793**

(22) Filed: **May 6, 2016**

(57) **ABSTRACT**

Described is a system for automatic adjustment of neurostimulation. The system controls stimulation of specific neural regions through a neural device positioned on a human subject, while simultaneously performing recordings from the neural device using a targeted arrangement of stimulating electrodes and distinct types of recording electrodes of the neural device. Stimulation of the specific neural regions is adjusted in real-time based on the recordings from the neural device.

**Related U.S. Application Data**

(63) Continuation-in-part of application No. 15/066,813, filed on Mar. 10, 2016.

(60) Provisional application No. 62/131,031, filed on Mar. 10, 2015, provisional application No. 62/159,151, filed on May 8, 2015.

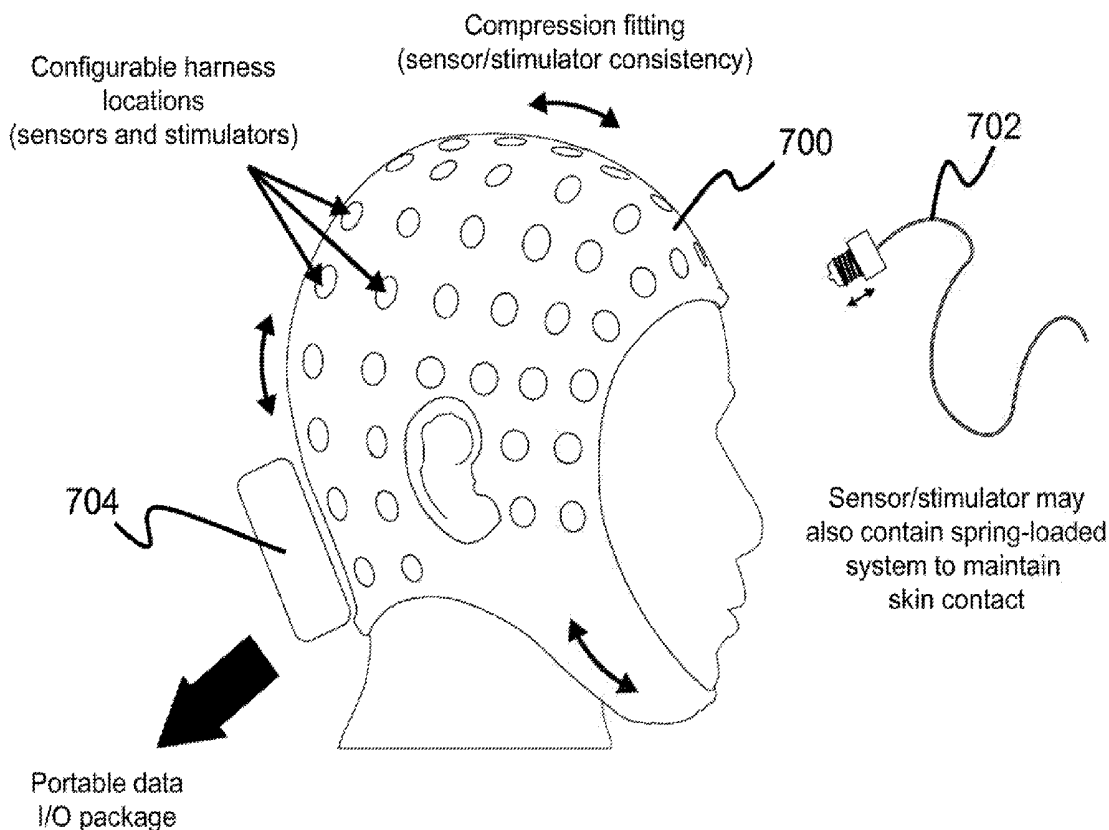

100

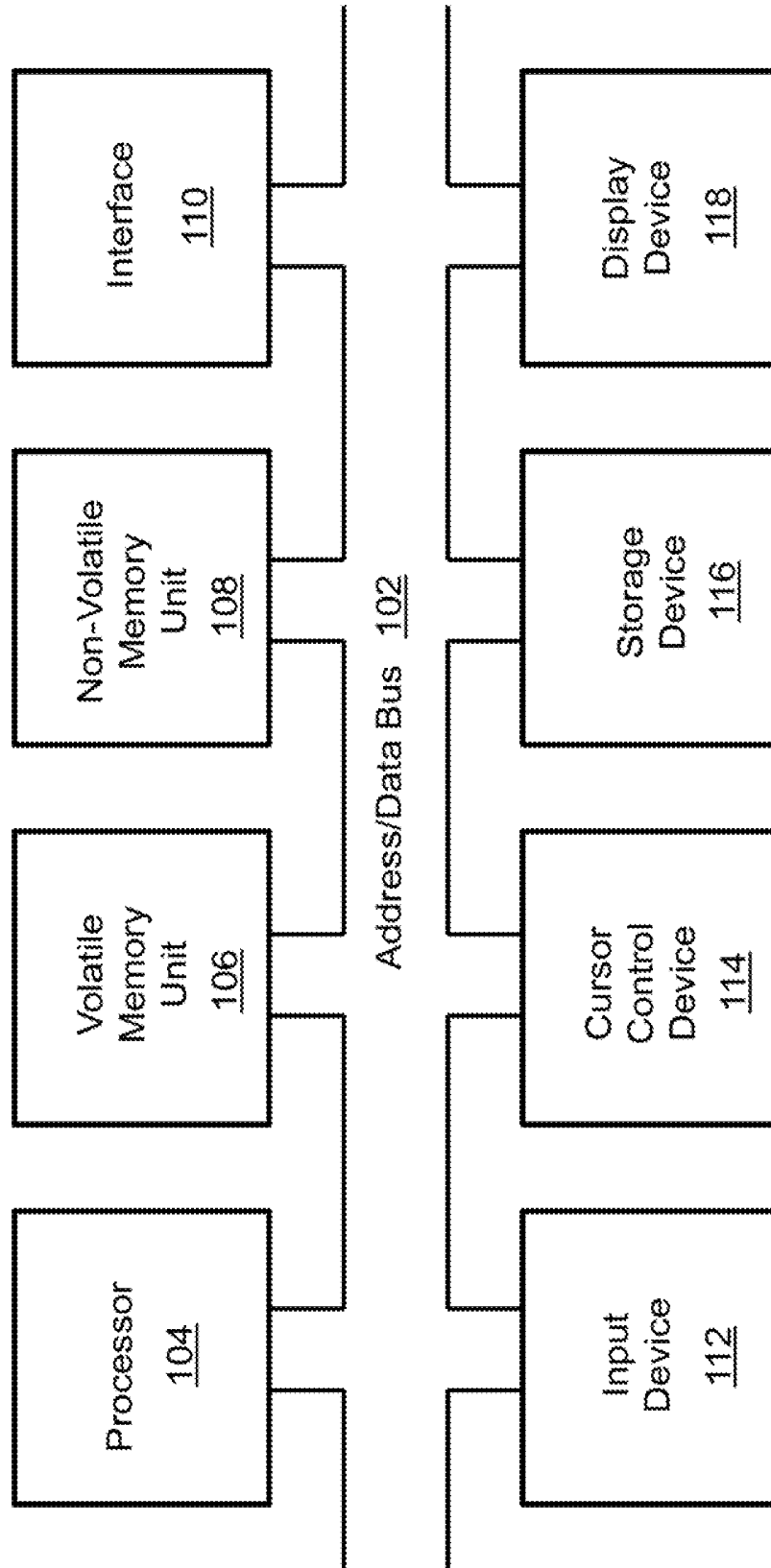

FIG. 1

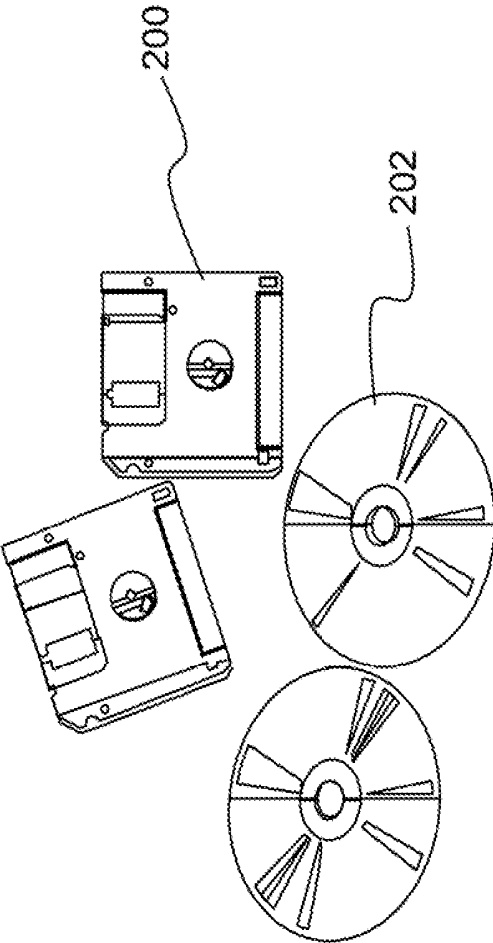

FIG. 2

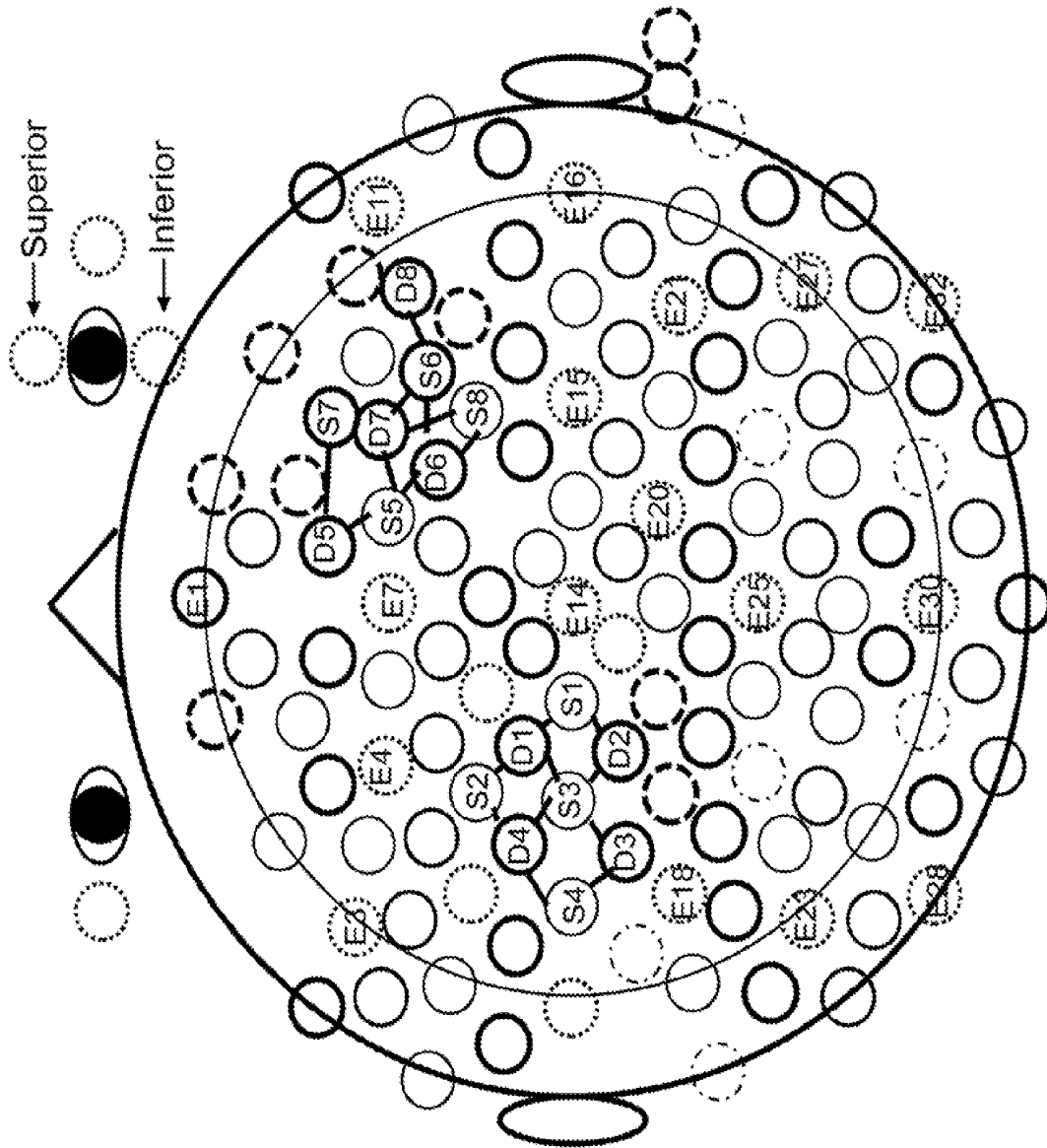

FIG. 3

### dIPFC Stimulation

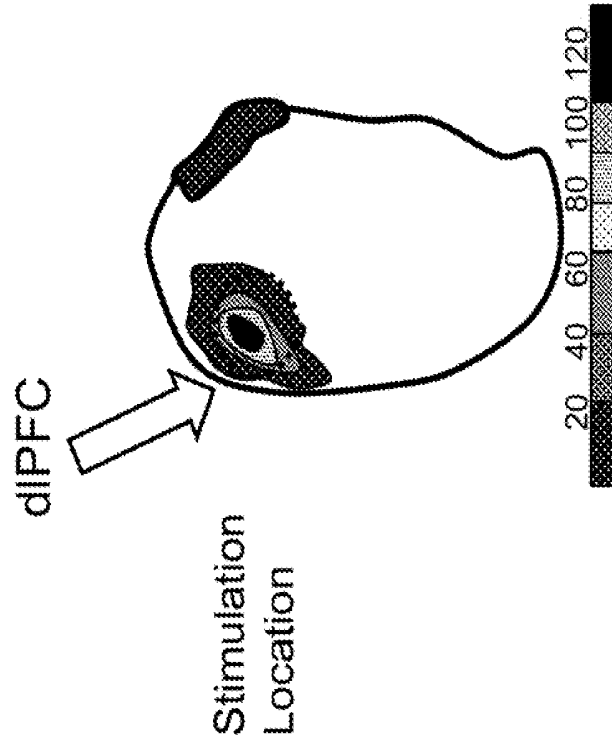

FIG. 4B

### Sham Stimulation

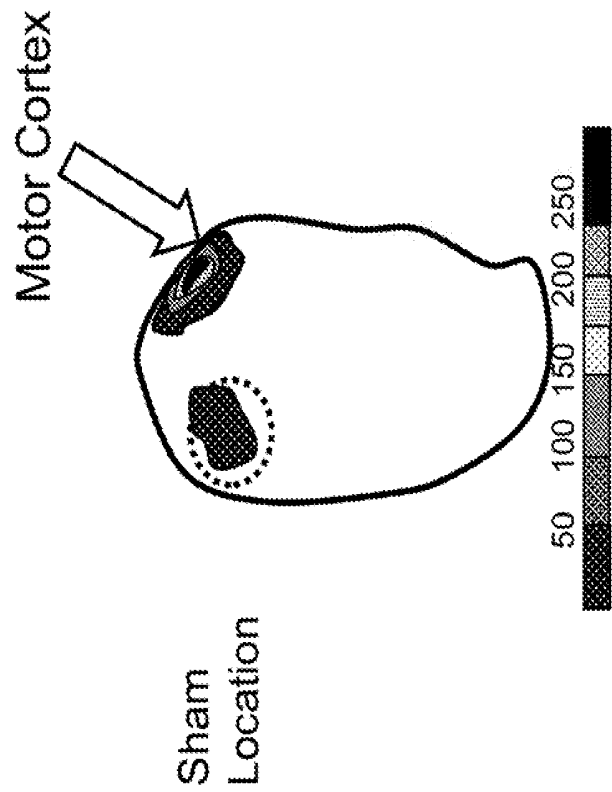

FIG. 4A

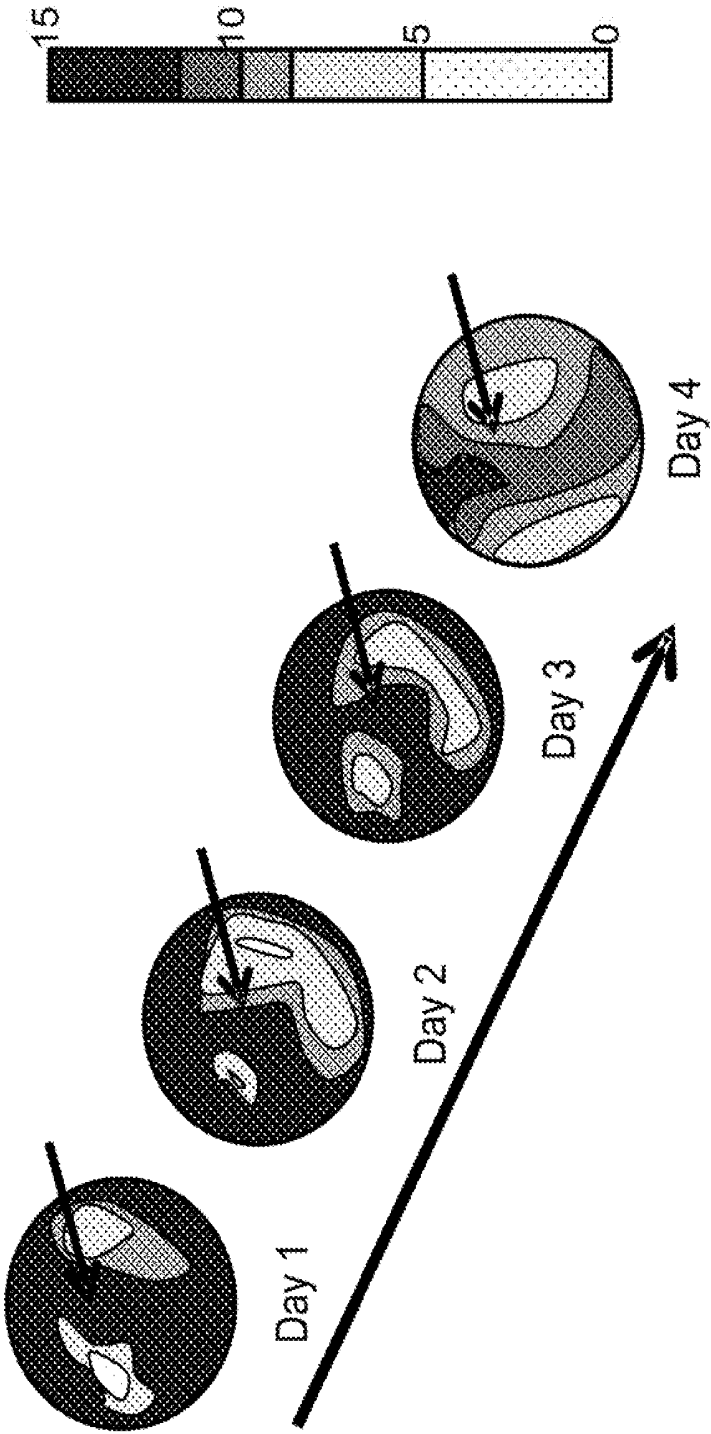

FIG. 4C

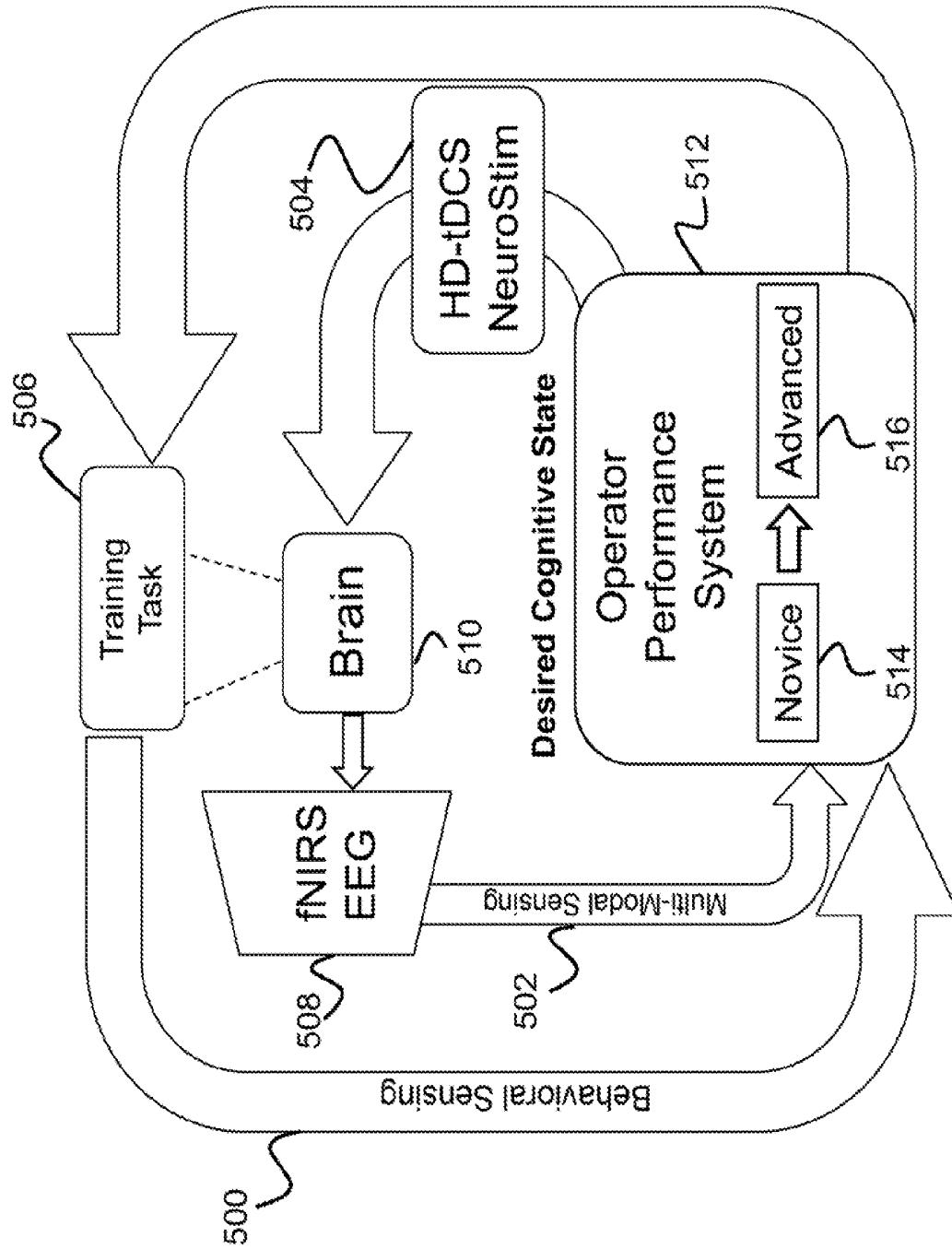

FIG. 5



FIG. 6

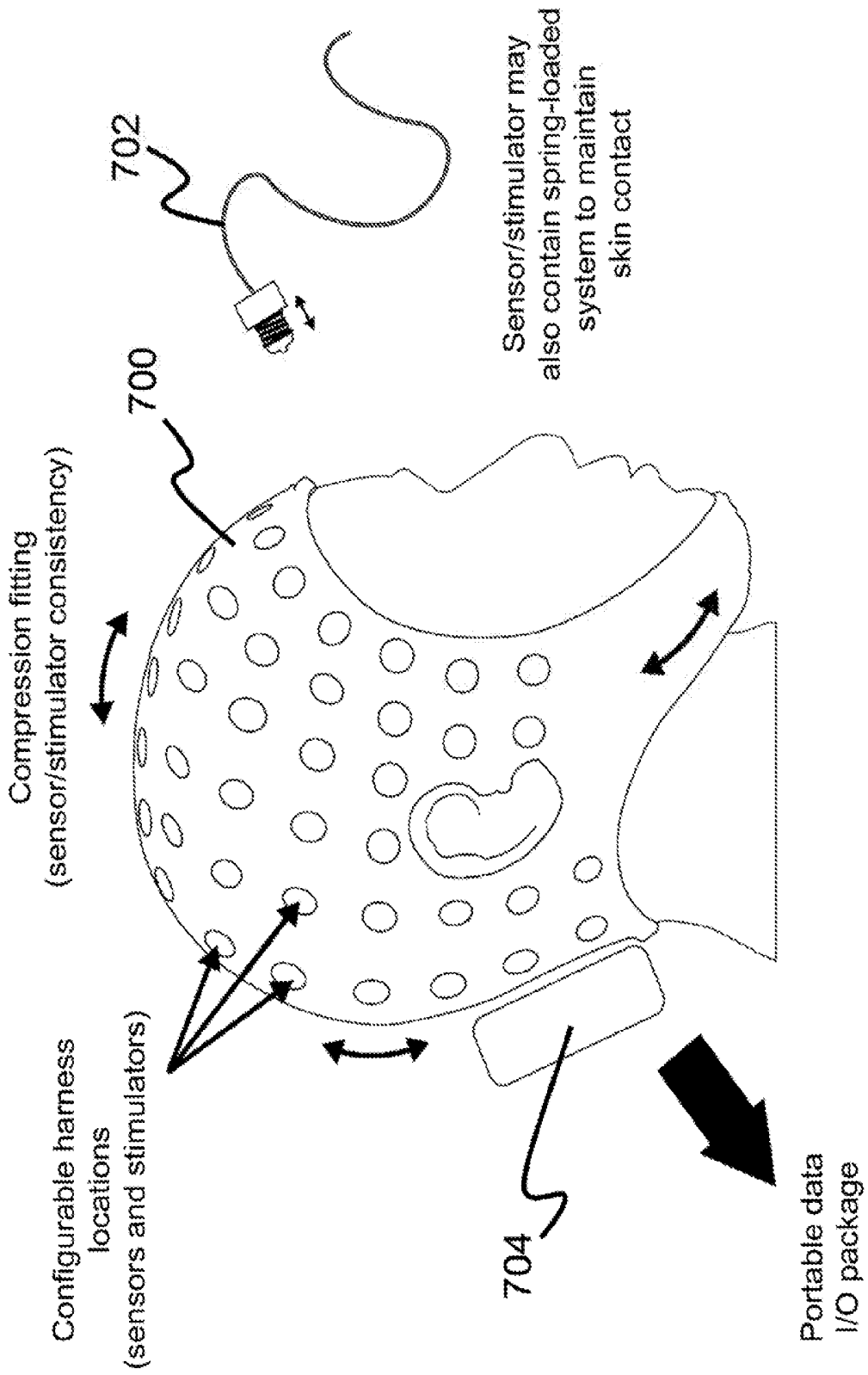

FIG. 7

**MONTAGE DESIGN FOR CLOSED LOOP  
SENSING AND NEUROSTIMULATION OF  
THE DORSAL LATERAL PREFRONTAL  
CORTEX AND/OR MOTOR CORTEX**

CROSS-REFERENCE TO RELATED  
APPLICATIONS

**[0001]** This is a Continuation-in-Part Application of U.S. application Ser. No. 15/066,813, filed in the United States on Mar. 10, 2016, entitled, "System and Method for Training and Assessment," which is a Non-Provisional Application of Provisional Application No. 62/131,031, filed in the United States on Mar. 10, 2015, entitled, "A Method for Pilot Training and Assessment," the entirety of which are incorporated herein by reference.

**[0002]** This is also a Non-Provisional Application of U.S. Provisional Patent Application No. 62/159,151 filed May 8, 2015, entitled, "Montage Design for Closed Loop Sensing and Neurostimulation of the Dorsal. Lateral Prefrontal Cortex and/or Motor Cortex," the entirety of which is incorporated herein by reference.

BACKGROUND OF INVENTION

(1) Field of Invention

**[0003]** The present invention relates to a system for adjusting neurostimulation and, more particularly, to a system for adjusting neurostimulation based on real-time sensing of brain states.

(2) Description of Related Art

**[0004]** Neurostimulation is a therapeutic activation of part of the nervous system using electrodes. Current techniques use a combination of electroencephalogram (EEG)/transcranial direct-current stimulation (tDCS) or functional near-infrared spectroscopy (fNIRS)/tDCS to target a variety of regions. Current state-of-the-art montages only provide either temporal (EEG) or spatial (tNIRS) information and do not provide all possible information about the current state of the brain, leading to possible misalignment and settings for neurostimulation.

**[0005]** Currently, brain imaging and planning of new stimulation occurs after the stimulation has been completed, such as described by Datta et al. in "Validation of finite element model of transcranial electrical stimulation using scalp potentials: Implications for clinical dose," *J Neural Engineering* 2013; 10(3), which is hereby incorporated by reference as though fully set forth herein. While operable for imaging after stimulation, such existing methods do not allow for simultaneous stimulation and recording or imaging. Thus, a continuing need exists for a system for adapting neurostimulation based on simultaneous recordings of the brain.

SUMMARY OF THE INVENTION

**[0006]** The present invention relates to a system for adjusting neurostimulation and, more particularly, to a system for adjusting neurostimulation based on real-time sensing of brain states. The system comprises one or more processors and a memory having instructions such that when the instructions are executed, the one or more processors perform multiple operations. The system stimulates specific neural regions through a neural device, while simultane-

ously performing recordings from the neural device using a targeted arrangement of stimulating electrodes and distinct types of recording electrodes of the neural device. Stimulation of the specific neural regions is adjusted in real-time based on the recordings from the neural device.

**[0007]** In another aspect, the system sets stimulation parameters to optimize any neural changes recorded by the recording electrodes to match a desired neural activity.

**[0008]** In another aspect, the system provides feedback of both temporal neural, changes and region specific neural changes via electroencephalogram (EEG) electrodes and functional near-infrared spectroscopy (fNIRS), electrodes, respectively.

**[0009]** In another aspect, preferred positions of stimulating electrodes on the neural device are provided that will focus effects of the stimulation on the specific neural regions while still allowing concentrated recordings of the specific neural regions.

**[0010]** In another aspect, stimulation is applied to a specific brain region, wherein the stimulation to be applied is determined by stimulation parameters determined based on prior recordings.

**[0011]** In another aspect, the stimulation is adjusted to decrease stimulation in one brain region and increase stimulation in another brain region.

**[0012]** In another aspect, the present invention comprises a method for automatic adjustment of neurostimulation. A targeted arrangement of stimulating electrodes and distinct types of recording electrodes is created for individualized stimulation. Stimulation of specific neural regions through a neural device, while simultaneously performing recordings from the neural device using the targeted arrangement of stimulating electrodes and distinct types of recording electrodes. Stimulation of the specific neural regions is adjusted in real-time based on the recordings from the neural device.

**[0013]** In another aspect, the neural device is a neural cap.

**[0014]** In another aspect, the present invention also comprises a method for causing a processor to perform the operations described herein.

**[0015]** Finally, in yet another aspect, the present invention also comprises a computer program product comprising computer-readable instructions stored on a non-transitory computer-readable medium that are executable by a computer having a processor for causing the processor to perform the operations described herein.

BRIEF DESCRIPTION OF THE DRAWINGS

**[0016]** The objects, features and advantages of the present invention will be apparent from the following detailed descriptions of the various aspects of the invention in conjunction with reference to the following drawings, where:

**[0017]** FIG. 1 is a block diagram depicting the components of a system for adjusting neurostimulation according to embodiments of the present disclosure;

**[0018]** FIG. 2 is an illustration of a computer program product according to embodiments of the present disclosure;

**[0019]** FIG. 3 is an illustration of an example arrangement of functional near-infrared spectroscopy (fNIRS), electroencephalography (EEG), and transcranial direct-current stimulation (tDCS) electrodes according to embodiments of the present disclosure;

**[0020]** FIG. 4A is an illustration of a control condition according to embodiments of the present disclosure;

[0021] FIG. 4B is an illustration of a stimulation condition according to embodiments of the present disclosure;

[0022] FIG. 4C is an illustration of topographic maps of wavelet-transformed data according to embodiments of the present disclosure;

[0023] FIG. 5 is an illustration of a closed loop system for adjusting neurostimulation parameters according to various embodiments of the present disclosure;

[0024] FIG. 6 illustrates a human subject receiving neurostimulation via a neural device according to some embodiments of the present disclosure; and

[0025] FIG. 7 illustrates a neural cap worn by a human subject for sensing and neurostimulation according to embodiments of the present disclosure.

#### DETAILED DESCRIPTION

[0026] The present invention relates to a system for adjusting neurostimulation and, more particularly, to a system for adjusting neurostimulation based on real-time sensing of brain states. The following description, is presented to enable one of ordinary skill in the art to make and use the invention and to incorporate it in the context of particular applications. Various modifications, as well as a variety of uses in different applications will be readily apparent to those skilled in the art, and the general principles defined herein may be applied to a wide range of aspects. Thus, the present invention is not intended to be limited to the aspects presented, but is to be accorded the widest scope consistent with the principles and novel features disclosed herein.

[0027] In the following detailed description, numerous specific details are set forth in order to provide a more thorough understanding of the present invention. However, it will be apparent to one skilled in the art that the present invention may be practiced without necessarily being limited to these specific details. In other instances, well-known structures and devices are shown in block diagram form, rather than in detail, in order to avoid obscuring the present invention.

[0028] The reader's attention is directed to all papers and documents which are filed concurrently with this specification and which are open to public inspection with this specification, and the contents of all such papers and documents are incorporated herein by reference. All the features disclosed in this specification, (including any accompanying claims, abstract, and drawings) may be replaced by alternative features serving the same, equivalent or similar purpose, unless expressly stated otherwise. Thus, unless expressly stated otherwise, each feature disclosed is one example only of a generic series of equivalent or similar features.

[0029] Furthermore, any element in a claim that does not explicitly state "means for" performing a specified function, or "step for" performing a specific function, is not to be interpreted as a "means" or "step" clause as specified in 35 U.S.C. Section 112, Paragraph 6. In particular, the use of "step of" or "act of" in the claims herein is not intended to invoke the provisions of 35 U.S.C. 112, Paragraph 6.

[0030] Please note, if used, the labels left, right, front, back, top, bottom, forward, reverse, clockwise and counter-clockwise have been used for convenience purposes only and are not intended to imply any particular fixed direction. Instead, they are used to reflect relative locations and/or

directions between various portions of an object. As such, as the present invention is changed, the above labels may change their orientation.

#### (1) Principal Aspects

[0031] Various embodiments of the invention include three "principal" aspects. The first is a system for adjusting neurostimulation. The system is typically in the form of a computer system operating software or in the form of a "hard-coded" instruction set. This system may be incorporated into a wide variety of devices that provide different functionalities. The second principal aspect is a method, typically in the form of software, operated using a data processing system (computer). The third principal aspect is a computer program product. The computer program product generally represents computer-readable instructions stored on a non-transitory computer-readable medium such as an optical storage device, e.g., a compact disc (CD) or digital versatile disc (DVD), or a magnetic storage device such as a floppy disk or magnetic tape. Other, non-limiting examples of computer-readable media include hard disks, read-only memory (ROM), and flash-type memories. These aspects will be described in more detail below.

[0032] A block diagram depicting an example of a system (i.e., computer system 100) of the present invention is provided in FIG. 1. The computer system 100 is configured to perform calculations, processes, operations, and/or functions associated with a program or algorithm. In one aspect, certain processes and steps discussed herein are realized as a series of instructions (e.g., software program) that reside within computer readable memory units and are executed by one or more processors of the computer system 100. When executed, the instructions cause the computer system 100 to perform specific actions and exhibit specific behavior, such as described herein.

[0033] The computer system 100 may include an address/data bus 102 that is configured, to communicate information. Additionally, one or more data processing units, such as a processor 104 (or processors), are coupled with the address/data bus 102. The processor 104 is configured to process information and instructions. In an aspect, the processor 104 is a microprocessor. Alternatively, the processor 104 may be a different type of processor such as a parallel processor, application-specific integrated circuit (ASIC), programmable logic array (PLA), complex programmable logic device (CPLD), or a field programmable gate array (FPGA).

[0034] The computer system 100 is configured to utilize one or more data storage units. The computer system 100 may include a volatile memory unit 106 (e.g., random access memory ("RAM"), static RAM, dynamic RAM, etc.) coupled with the address/data bus 102, wherein a volatile memory unit 106 is configured to store information and instructions for the processor 104. The computer system 100 further may include a non-volatile memory unit 108 (e.g., read-only memory ("ROM"), programmable ROM ("PROM"), erasable programmable ROM ("EPROM"), electrically erasable programmable ROM ("EEPROM"), flash memory, etc.) coupled with the address/data bus 102, wherein the non-volatile memory unit 108 is configured to store static information and instructions for the processor 104. Alternatively, the computer system 100 may execute instructions retrieved from an online data storage unit such as in "Cloud" computing. In an aspect, the computer system 100 also may include one or more interfaces, such as an

interface **110**, coupled with the address/data bus **102**. The one or more interfaces are configured to enable the computer system **100** to interface with other electronic devices and computer systems. The communication interfaces implemented by the one or more interfaces may include wireline (e.g., serial cables, modems, network adaptors, etc.) and/or wireless (e.g., wireless modems, wireless network adaptors, etc.) communication technology.

[0035] In one aspect, the computer system **100** may include an input device **112** coupled with the address/data bus **102**, wherein the input device **112** is configured to communicate information and command selections to the processor **100**. In accordance with one aspect, the input device **112** is an alphanumeric input device, such as a keyboard, that may include alphanumeric and/or function keys.

[0036] Alternatively, the input device **112** may be an input device other than an alphanumeric input device. In an aspect, the computer system **100** may include a cursor control device **114** coupled with the address/data bus **102**, wherein the cursor control device **114** is configured to communicate user input information and/or command selections to the processor **100**. In an aspect, the cursor control device **114** is implemented using a device such as a mouse, a track-ball, a track-pad, an optical tracking device, or a touch screen. The foregoing notwithstanding, in an aspect, the cursor control device **114** is directed and/or activated via input from the input device **112**, such as in response to the use of special keys and key sequence commands associated with the input device **112**. In an alternative aspect, the cursor control device **114** is configured to be directed or guided by voice commands.

[0037] In an aspect, the computer system **100** further may include one or more optional computer usable data storage devices, such as a storage device **116**, coupled with the address/data bus **102**. The storage device **116** is configured to store information, and/or computer executable instructions. In one aspect, the storage device **116** is a storage device such as a magnetic or optical disk drive (e.g., hard disk drive (“HDD”), floppy diskette, compact disk read only memory (“CD-ROM”), digital versatile disk (“DVD”). Pursuant to one aspect, a display device **118** is coupled with the address/data bus **102**, wherein the display device **118** is configured to display video and/or graphics. In an aspect, the display device **118** may include: a cathode ray tube (“CRT”), liquid crystal display (“LCD”), field emission display (“FED”), plasma display, or any other display device suitable for displaying video and/or graphic images and alphanumeric characters recognizable to a user.

[0038] The computer system **100** presented herein is an example computing environment in accordance with an aspect. However, the non-limiting example of the computer system **100** is not strictly limited to being a computer system. For example, an aspect provides that the computer system **100** represents a type of data processing analysis that may be used in accordance with various aspects described herein. Moreover, other computing systems may also be implemented. Indeed, the spirit and scope of the present technology is not limited to any single data processing environment. Thus, in an aspect, one or more operations of various aspects of the present technology are controlled or implemented using computer-executable instructions, such as program modules, being executed by a computer. In one implementation) such program modules include routines,

programs, objects, components and/or data structures that are configured to perform particular tasks or implement particular abstract data types. In addition, an aspect provides that one or more aspects of the present technology are implemented by utilizing one or more distributed computing environments, such as where tasks are performed by remote processing devices that are linked through a communications network, or such as where various program modules are located in both local and remote computer-storage media including memory-storage devices.

[0039] An illustrative diagram of a computer program product (i.e., storage device) embodying the present invention is depicted in FIG. 2. The computer program product is depicted as floppy disk **200** or an optical disk **202** such as a CD or DVD. However, as mentioned previously, the computer program product generally represents computer-readable instructions stored on any compatible non-transitory computer-readable medium. The term “instructions” as used with respect to this invention generally indicates a set of operations to be performed on a computer, and may represent pieces of a whole program or individual, separable, software modules. Non-limiting examples of “instruction” include computer program code (source or object code) and “hard-coded” electronics (i.e. computer operations coded into a computer chip). The “instruction” is stored on any non-transitory computer-readable medium, such as in the memory of a computer or on a floppy disk, a CD-ROM, and a flash drive. In either event, the instructions are encoded on a non-transitory computer-readable medium.

## (2) Specific Details of Various Embodiments

[0040] Described is a method for using non-invasive transcranial direct current stimulation (tDCS) of neurons in specific regions of the brain (e.g., motor cortex and/or dorsal lateral prefrontal cortex (dlPFC)) while simultaneously recording neural activity via electroencephalography (EEG) from the entire brain and functional near-infrared spectroscopy (fNIRS) from specific regions of the brain (e.g., motor cortex and dlPFC). The specific placement of each electrode for stimulating and recording allows for a novel focality in stimulation to the desired regions (based on an average adult male’s head) while also allowing for full coverage from the recording electrodes. The ability to monitor the brain activity of, for instance, the dlPFC and motor cortex in real-time allows for a closed-loop system that will alter the stimulation settings to match desired dlPFC and motor cortex neural activity.

[0041] The system according to embodiments of the present disclosure provides a unique approach to stimulating and recording from specific brain regions such that the different modalities cause minimal interference with each other while maintaining full coverage of the regions of interest. While each of the electrode modalities e.g., EEG, fNIRS, tDCS) has been used individually to target the motor cortex and dlPFC, the system according to various embodiments of the present disclosure uses all three modalities simultaneously.

[0042] By using this “montage” of electrodes, there is an unprecedented level of coverage to monitor the effects of neural stimulation to the motor cortex and/or the dlPFC in real-time. This will improve the ability to accurately set the levels of stimulation to optimize any neural changes to match the desired activity. By using EEG and fNIRS, the

present invention will provide feedback of both temporal brain changes (via EEG) and region specific changes (via tNIRS).

[0043] The ability to monitor brain states in real-time during stimulation will allow adjustments to be made to the stimulation setting based off of the changes to the activation pattern caused by the neurostimulation. Currently, brain imaging and planning of new stimulation occurs after the stimulation has been completed. By having localized brain imaging of the regions being stimulated, the system described herein has the unique ability to monitor and adapt stimulation settings to reach a desired change in neural activity.

[0044] FIG. 3 depicts the placement of stimulating electrodes, fNIRS electrodes, and EEG electrodes on a head of a subject. The electrodes are represented by small circles. E represents EEG electrodes, S represents source electrodes, and D represents, detector electrodes. Stimulation sites are represented by bold dashed circles. Bold lines connecting electrodes represent data channels of interest. The present invention functions by placing the stimulating electrodes (represented by bold dashed circles) at locations that will focus the effects of the stimulation on the brain region desired (e.g., motor cortex and/or dlPFC) while still allowing very concentrated recordings of the spatial areas of the regions by the functional near infrared spectroscopy (fNIRS) electrodes (i.e., electrodes with “S” “D”).

[0045] Additionally, the EEG electrodes are not interfered with and provide detailed coverage over the entire head allowing for maximal information received. This information can then be analyzed and used to reset the stimulation parameters based on the accurate recordings made from the stimulation. FIGS. 4A, 4B and 4C show results of the montage depicted in FIG. 3, providing evidence of the ability of both EEG and fNIRS to record changes that occur during stimulation with this montage. A sham stimulation (FIG. 4A) (i.e., control condition) indicates a stimulation protocol that conveys the perception of being stimulated to the subject, but does not deliver the current to the brain. FIG. 4B depicts the actual stimulation condition in which the current is delivered to the dlPFC as depicted. Without a montage such as the one illustrated in FIG. 3, these changes would not be able to be analyzed and understood.

[0046] Specifically, FIGS. 4A and 4B depict simultaneous recording of fNIRS with tDCS showing the difference in location activities caused by tDCS. FIG. 4C depicts simultaneous recording of EEG with tDCS showing the difference in timing activities caused by tDCS. FIG. 4C illustrates topographic maps of wavelet-transformed data. The smaller arrows point to significant changes in the midline frontal theta spectral power across days, which corresponds to skill acquisition. The large arrow depicts the progression of the subjects over the training regime of 4 days.

[0047] Closed loop stimulation adaptation is unique to the present invention. FIG. 5 illustrates the architecture for a closed stimulation adaptation that measures behavioral output (e.g., piloting improvements) via behavioral sensing 500 and multi-modal sensing 502 to adapt the stimulation (HD-tDCS neurostimulation 504) to a pattern that is fitting for the current level of expertise of the user and a training task 506 at hand. Behavioral sensing is performed by, for example, custom software written to read flight-recorder-like data from the simulation, which was then used to compare the behavioral performance within subjects an also

across subject conditions. Behavioral sensing are specific to the skill being trained. For example, the sensing may be based on quantitative metrics of pilot skill, such as G-force at landing). Multi-modal sensing 502 is performed by, for instance, fNIRS and EEG 508, which record neural activity in the brain 510 of the user. In combination with an operator performance system 512, the measurements from the multi-modal sensing 502 are used to automatically adjust stimulation parameters for HD-tDCS neurostimulation 504 of areas of the user's brain 510 in order to reach a desired cognitive state to improve the user's performance of the training task 506.

[0048] For example, the system according to various embodiments can be used to assist a complete novice being introduced to a task in which they must fly a plane through high turbulence. Using the present invention, the user will receive a computed stimulation (HD-tDCS neurostimulation 504) in a specific area, such as the motor cortex. The stimulation (HD-tDCS neurostimulation 504) is computed based on recordings from expert pilots and other novice pilots as well as a comparison of their fNIRS and EEG measurements and behaviors to the current novice pilot. It is critical to determine the typical variance of various novice pilots to optimize learning and stimulation parameters. In addition, individual phenotypes of behavior can be used to personalize stimulation montage for optimum learning. However, as the current novice pilot's performance improves, the model adapts the stimulation to decrease stimulation in the motor cortex, but increase the decision making aspect of the pilot's brain and target the dlPFC. This adjustment is performed as an evolving system that adapts stimulation based on the current recorded expert pilots and the novice pilot's improvements. The goal is to improve the performance of the novice 514 pilot to the level of the advanced 516 pilot.

[0049] FIG. 6 illustrates a human subject 600 receiving neurostimulation according to some embodiments of the present disclosure. A neural device 602 able to generate an electrical current delivers neurostimulation by applying a current through one electrode 604 (e.g., anode), and it flows through the brain to another electrode 606 (e.g., cathode). The neural device 602 is depicted as a patch that adheres to a portion of the patient's head. Any suitable neural device 602 can be used (such as the neural cap described below) provided that it can control stimulation of specific neural regions while performing recordings from the neural device 602 using a targeted arrangement of stimulating electrodes and recording electrodes of the neural device 602.

[0050] FIG. 7 illustrates a neural device worn by a human subject for sensing and neurostimulation according to embodiments of the present disclosure. As depicted in FIG. 7, the neural device is a neural cap 700. As shown, the neural cap 700 may have configurable harness locations for stimulators and sensors. Additionally, the sensor/stimulator may contain a spring-loaded system 702 to maintain skin contact. Compression fitting of the neural cap 700 achieves sensor/stimulator consistency. Furthermore, the neural cap 700 can be connected to portable data input/output (I/O) package 704.

[0051] Finally, while this invention has been described in terms of several embodiments, one of ordinary skill in the art will readily recognize that the invention may have other applications in other environments. It should be noted that many embodiments and implementations are possible. Fur-

ther, the following claims are in no way intended to limit the scope of the present invention to the specific embodiments described above. In addition, any recitation of “means for” is intended to evoke a means-plus-function reading of an element and a claim, whereas, any elements that do not specifically use the recitation “means for”, are not intended to be read as means-plus-function elements, even if the claim otherwise includes the word “means”. Further, while particular method steps have been recited in a particular order, the method steps may occur in any desired order and fall within the scope of the present invention.

What is claimed is:

1. A system for automatic adjustment of neurostimulation, the system comprising:

one or more processors and a non-transitory memory having instructions encoded thereon such that when the instructions are executed, the one or more processors perform operations of:

controlling stimulation of specific neural regions through a neural device, while simultaneously performing recordings from the neural device using a targeted arrangement of stimulating electrodes and distinct types of recording electrodes of the neural device; and

adjusting stimulation of the specific neural regions in real-time based on the recordings from the neural device.

2. The system as set forth in claim 1, wherein the one or more processors further perform an operation of setting stimulation parameters to optimize any neural changes recorded by the recording electrodes to match a desired neural activity.

3. The system as set forth in claim 1, wherein the one or more processors further perform an operation of providing feedback of both temporal neural changes and region specific neural changes via electroencephalogram (EEG) electrodes and functional near-infrared spectroscopy (fNIRS) electrodes, respectively,

4. The system as set forth in claim 1, wherein the one or more processors further perform an operation of providing preferred positions of stimulating electrodes on the neural device that will focus effects of the stimulation on the specific neural regions while still allowing concentrated recordings of the specific neural regions.

5. The system as set forth in claim 1, wherein the one or more processors further perform an operation of applying stimulation to a specific brain region, wherein the stimulation to be applied is determined by stimulation parameters determined based on prior recordings.

6. The system as set forth in claim 5, wherein the one or more processors further perform an operation of adjusting the stimulation to decrease stimulation in one brain region and increase stimulation in another brain region.

7. A computer-implemented method for automatic adjustment of neurostimulation, comprising:

an act of causing one or more processors to execute instructions stored on a non-transitory memory such that upon execution, the one or more processors perform operations of:

controlling stimulation of specific neural regions through a neural device, while simultaneously performing recordings from the neural device using a targeted arrangement of stimulating electrodes and distinct types of recording electrodes of the neural device; and

adjusting stimulation of the specific neural regions in real-time based on the recordings from the neural device.

8. The method as set forth in claim 7, wherein the one or more processors further perform an operation of setting stimulation parameters to optimize any neural changes recorded by the recording electrodes to match a desired neural activity.

9. The method as set forth in claim 7, wherein the one or more processors further perform an operation of providing feedback of both temporal neural changes and region specific neural changes via electroencephalogram (EEG) electrodes and functional near-infrared spectroscopy (fNIRS) electrodes, respectively.

10. The method as set forth in claim 7, wherein the one or more processors further perform an operation of providing preferred positions of stimulating electrodes on the neural device that will focus effects of the stimulation on the specific neural regions while still allowing concentrated recordings of the specific neural regions.

11. The method as set forth in claim 7, wherein the one or more processors further perform an operation of applying stimulation to a specific brain region, wherein the stimulation to be applied is determined by stimulation parameters determined based on prior recordings.

12. The method as set forth in claim 11, wherein the one or more processors further perform an operation of adjusting the stimulation to decrease stimulation in one brain region and increase stimulation in another brain region.

13. A computer program product for automatic adjustment of neurostimulation, the computer program product comprising:

computer-readable instructions stored on a non-transitory computer-readable medium that are executable by a computer having one or more processors for causing the processor to perform operations of:

controlling stimulation of specific neural regions through a neural device, while simultaneously performing recordings from the neural device using a targeted arrangement of stimulating electrodes and distinct types of recording electrodes of the neural device; and

adjusting stimulation of the specific neural regions in real-time based on the recordings from the neural device.

14. The computer program product as set forth in claim 13, further comprising instructions for causing the one or more processors to further perform an operation of setting stimulation parameters to optimize any neural changes recorded by the recording electrodes to match a desired neural activity.

15. The computer program product as set forth in claim 13, further comprising instructions for causing the one or more processors to further perform an operation of providing feedback of both temporal neural changes and region specific neural changes via electroencephalogram (EEG) electrodes and functional near-infrared spectroscopy (fNIRS) electrodes, respectively.

16. The computer program product as set forth in claim 13, further comprising instructions for causing the one or more processors to further perform an operation of providing preferred positions of stimulating electrodes on the neural device that will focus effects of the stimulation on the specific neural regions while still allowing concentrated recordings of the specific neural regions.

17. The computer program product as set forth in claim 13, further comprising instructions for causing the one or more processors to further perform an operation of applying stimulation to a specific brain region, wherein the stimulation to be applied is determined by stimulation parameters determined based on prior recordings.

18. The computer program product as set forth in claim 17, further comprising instructions for causing the one or more processors to further perform an operation of adjusting the stimulation to decrease stimulation in one brain region and increase stimulation in another brain region.

19. A method for automatic adjustment of neurostimulation, comprising acts of:

creating a targeted arrangement of stimulating electrodes and distinct types of recording electrodes for individualized stimulation through, a neural device

controlling, stimulation of specific neural regions through the neural device, while simultaneously performing recordings from the neural device using the targeted arrangement of stimulating electrodes and distinct types of recording electrodes of the neural device; and adjusting stimulation of the specific neural regions in real-time based on the recordings from the neural device.

20. The system as set forth in claim 1, wherein the neural device is a neural cap.

\* \* \* \* \*

专利名称(译)	蒙太奇设计用于闭环感知和背侧前额叶皮层和/或运动皮层的神经刺激		
公开(公告)号	<a href="#">US20170312518A1</a>	公开(公告)日	2017-11-02
申请号	US15/148793	申请日	2016-05-06
[标]申请(专利权)人(译)	赫尔实验室有限公司		
申请(专利权)人(译)	HRL实验室, LLC		
当前申请(专利权)人(译)	HRL实验室, LLC		
[标]发明人	ZIEGLER MATTHIAS CHOE JAEHOON PHILLIPS MATTHEW E		
发明人	ZIEGLER, MATTHIAS CHOE, JAEHOON PHILLIPS, MATTHEW E.		
IPC分类号	A61N1/36 A61N1/04 A61B5/00 A61B5/0478 A61N1/20		
CPC分类号	A61N1/36025 A61N1/0456 A61N1/0484 A61B5/4836 A61B5/0478 A61B5/0075 A61N1/20 A61B5/0036 A61N1/205		
优先权	62/131031 2015-03-10 US 62/159151 2015-05-08 US		
其他公开文献	US10376697		
外部链接	<a href="#">Espacenet</a> <a href="#">USPTO</a>		

摘要(译)

描述了一种用于自动调节神经刺激的系统。该系统通过位于人类对象上的神经装置控制特定神经区域的刺激，同时使用神经装置的刺激电极和不同类型的记录电极的目标布置来执行来自神经装置的记录。基于来自神经装置的记录实时调整特定神经区域的刺激。

