



US 20130303864A1

(19) **United States**  
(12) **Patent Application Publication**  
**Chen**

(10) **Pub. No.: US 2013/0303864 A1**  
(43) **Pub. Date: Nov. 14, 2013**

(54) **CLIP-STYLE MEDICAL SENSOR AND  
TECHNIQUE FOR USING THE SAME**

**Publication Classification**

- (71) Applicant: **Covidien LP, (US)**
- (72) Inventor: **Rodney P. Chen, Carson City, NV (US)**
- (21) Appl. No.: **13/868,794**
- (22) Filed: **Apr. 23, 2013**

- (51) **Int. Cl.**  
*A61B 5/1455* (2006.01)  
*A61B 5/00* (2006.01)
- (52) **U.S. Cl.**  
CPC ..... *A61B 5/14552* (2013.01); *A61B 5/443*  
(2013.01)  
USPC ..... **600/306; 600/340**

**Related U.S. Application Data**

- (63) Continuation of application No. 13/290,957, filed on Nov. 7, 2011, now Pat. No. 8,437,826, which is a continuation of application No. 11/415,717, filed on May 2, 2006, now Pat. No. 8,073,518.

(57) **ABSTRACT**

A clip-style pulse sensor may be adapted to apply limited, even pressure to a patient's tissue. A clip-style sensor is provided that reduces motion artifacts by exerting limited, uniform pressure to the patient tissue to reduce tissue exsanguination. Further, such a sensor provides a secure fit while avoiding discomfort for the wearer.

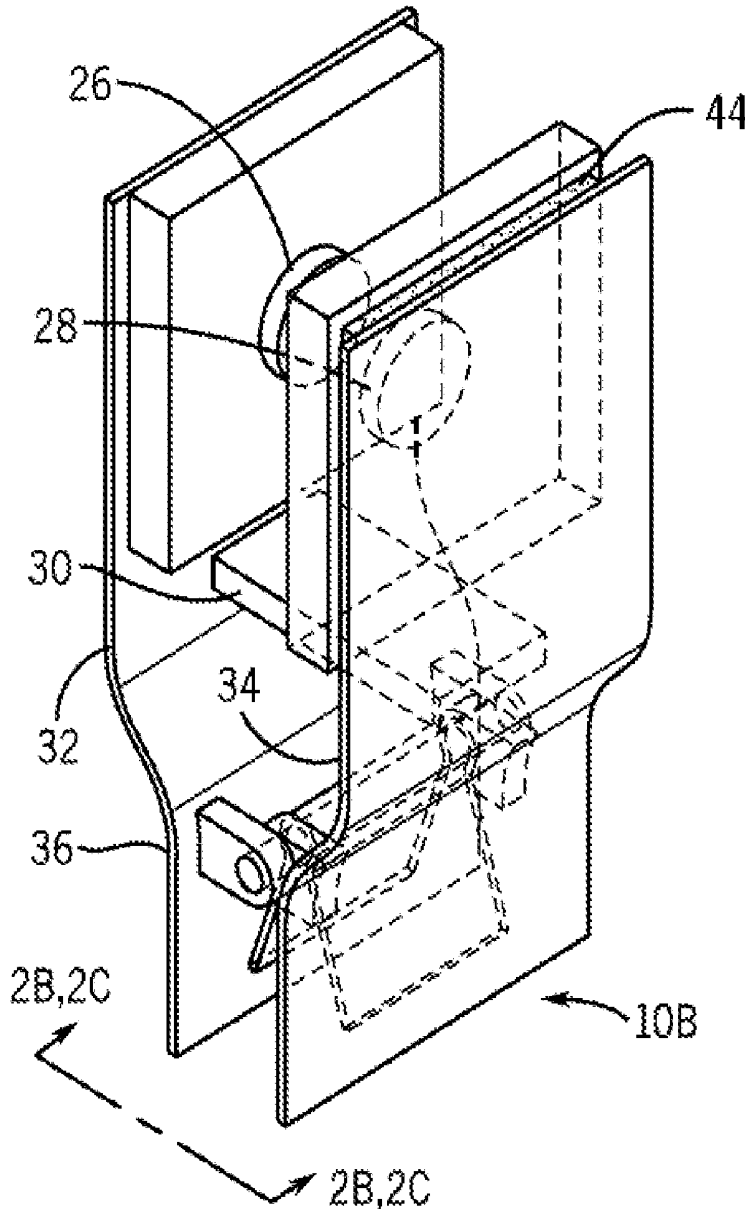

FIG. 1A

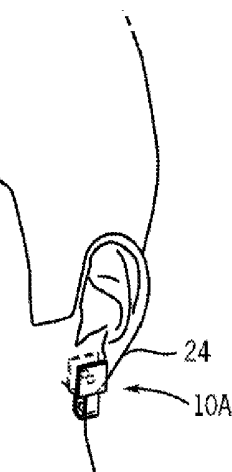
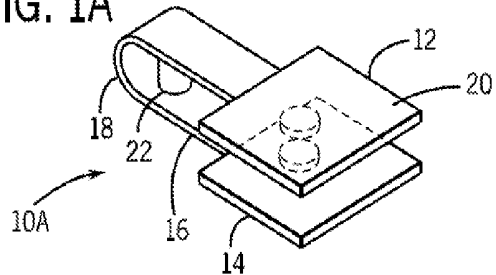

FIG. 1B

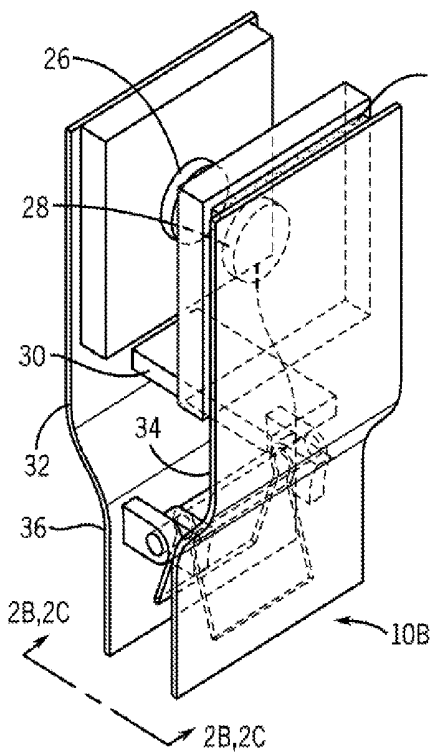

FIG. 2A

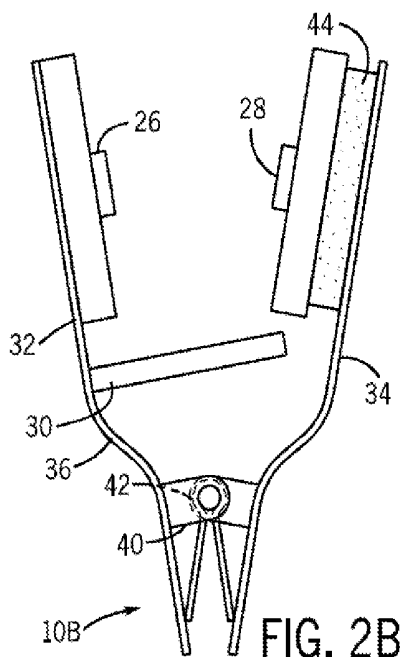
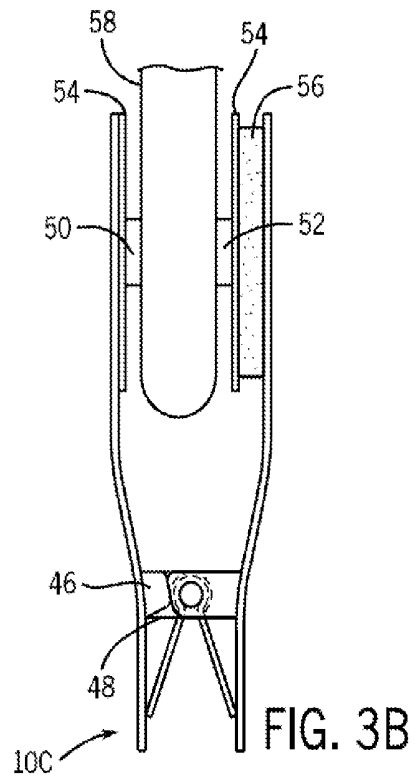
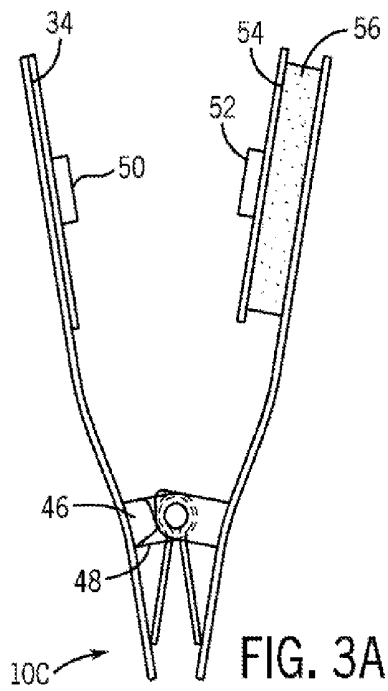
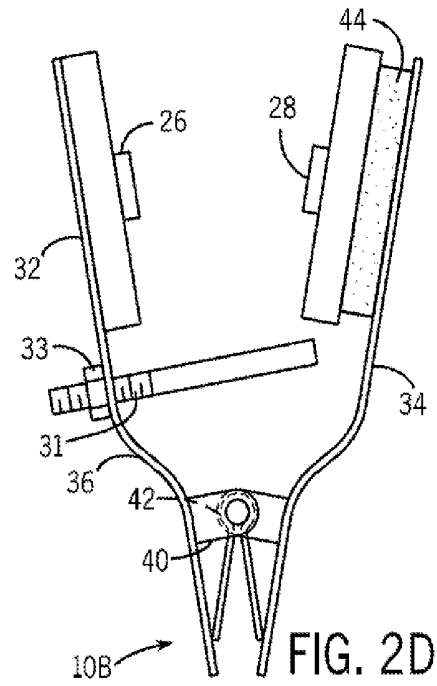
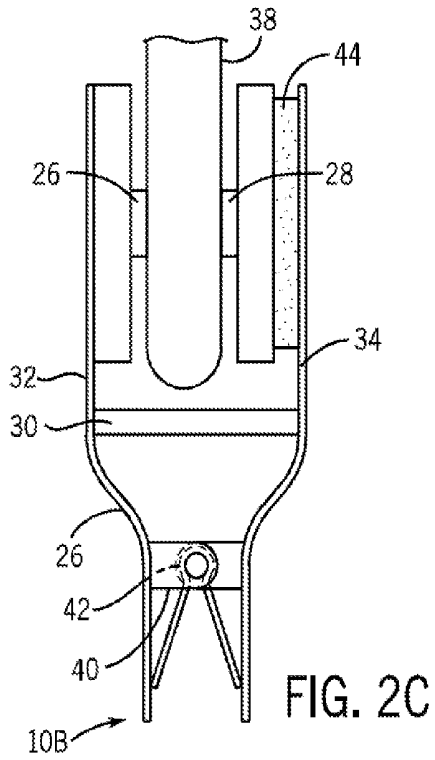

FIG. 2B



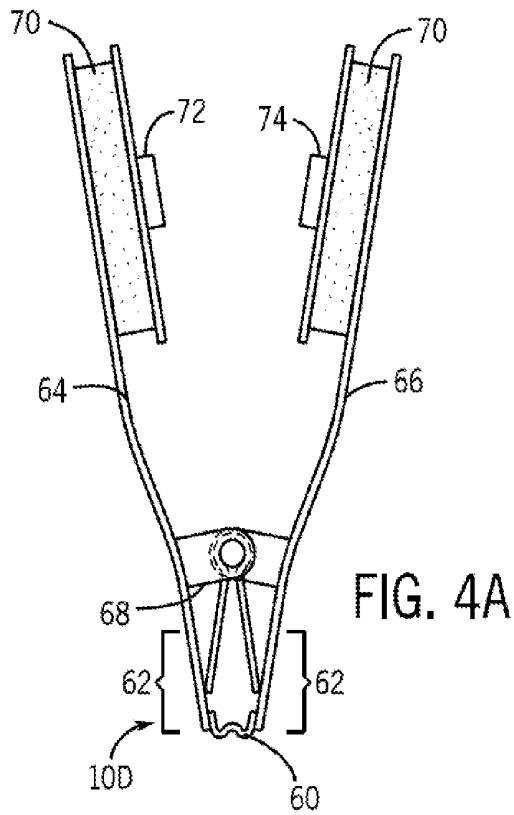

FIG. 4B

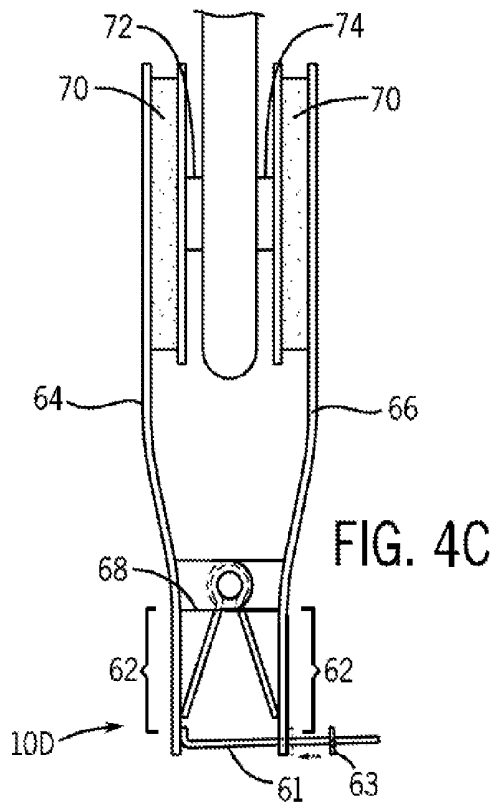
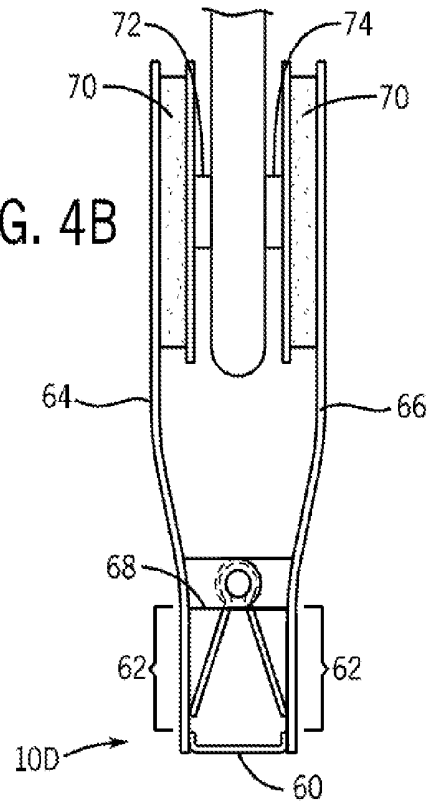
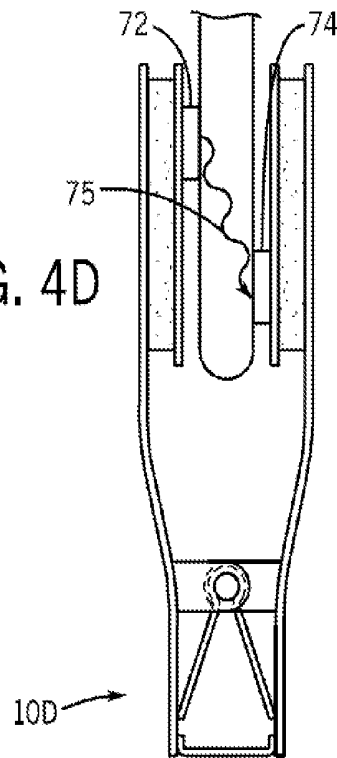

FIG. 4D



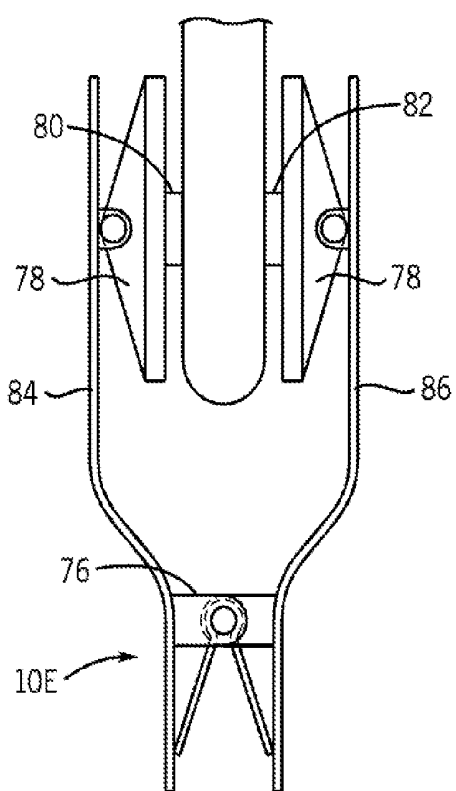

FIG. 5A

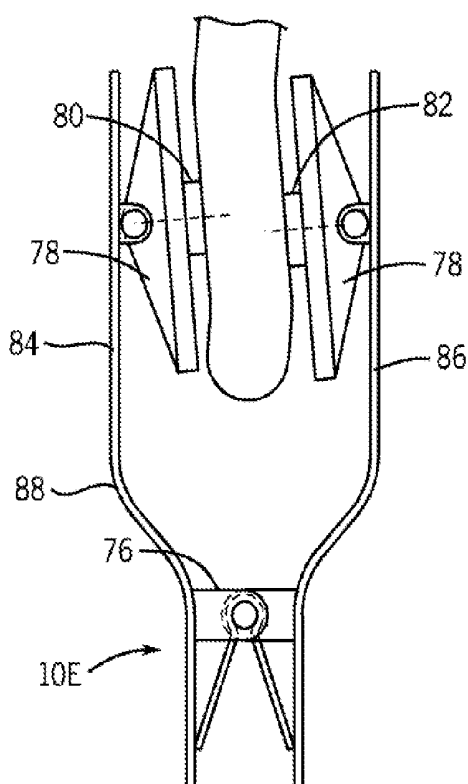

FIG. 5B

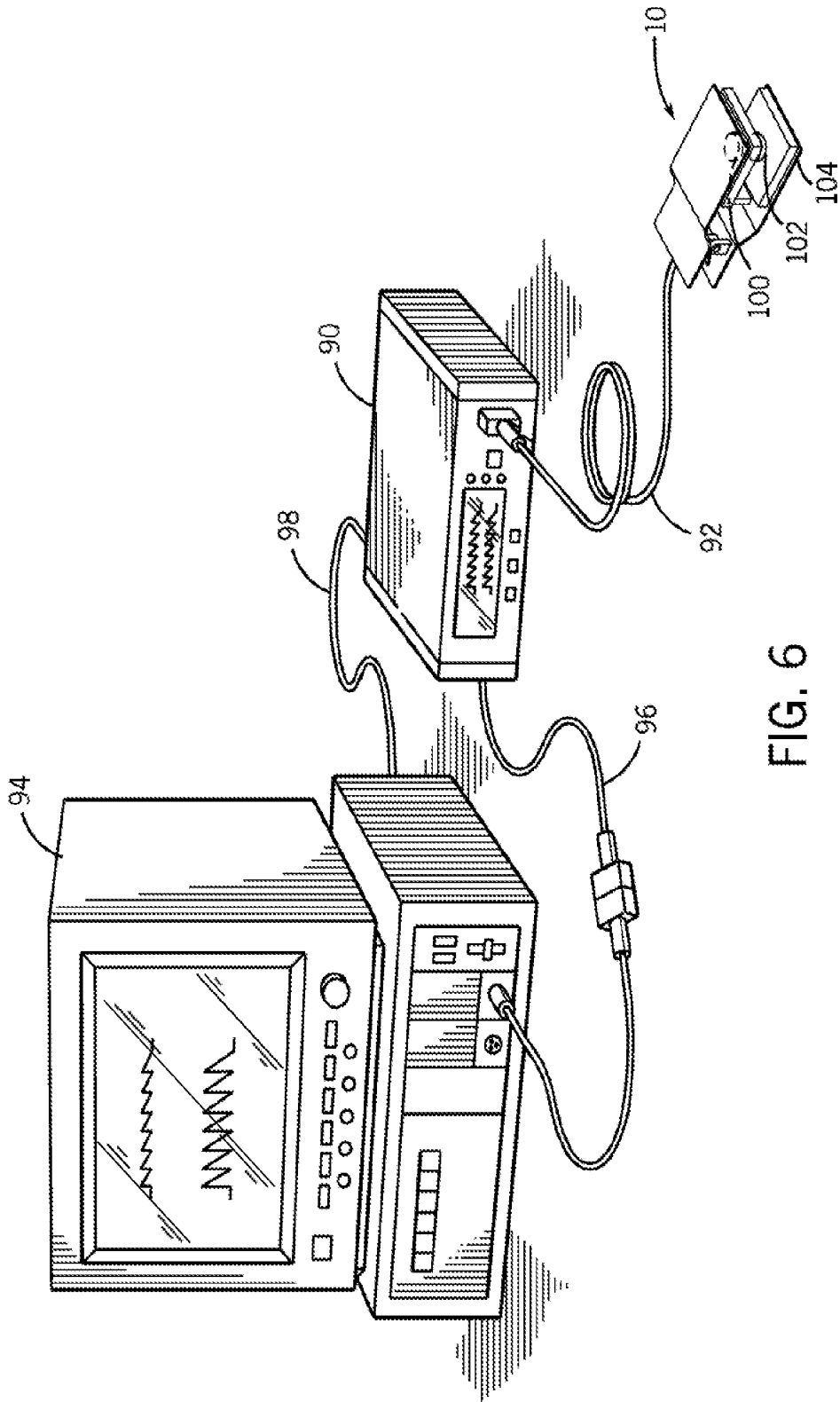

FIG. 6

## CLIP-STYLE MEDICAL SENSOR AND TECHNIQUE FOR USING THE SAME

### CROSS-REFERENCE TO RELATED APPLICATIONS

[0001] This application is a continuation of U.S. patent application Ser. No. 13/290,957, filed Nov. 7, 2011, which is a continuation of U.S. patent application No. Ser. 11/415,717, now U.S. Pat. No. 8,073,518, filed May 2, 2006, the specifications of which are incorporated by reference in their entireties herein for all purposes.

### BACKGROUND OF THE INVENTION

[0002] 1. Field of the Invention

[0003] The present invention relates generally to medical devices and, more particularly, to sensors used for sensing physiological parameters of a patient.

[0004] 2. Description of the Related Art

[0005] This section is intended to introduce the reader to various aspects of art that may be related to various aspects of the present invention which are described and/or claimed below. This discussion is believed to be helpful in providing the reader with background information to facilitate a better understanding of the various aspects of the present invention. Accordingly, it should be understood that these statements are to be read in this light, and not as admissions of prior art.

[0006] In the field of medicine, doctors often desire to monitor certain physiological characteristics of their patients. Accordingly, a wide variety of devices have been developed for monitoring many such physiological characteristics. Such devices provide doctors and other healthcare personnel with the information they need to provide the best possible healthcare for their patients. As a result, such monitoring devices have become an indispensable part of modern medicine.

[0007] One technique for monitoring certain physiological characteristics of a patient is commonly referred to as pulse oximetry, and the devices built based upon pulse oximetry techniques are commonly referred to as pulse oximeters. Pulse oximetry may be used to measure various blood flow characteristics, such as the blood-oxygen saturation of hemoglobin in arterial blood, the volume of individual blood pulsations supplying the tissue, and/or the rate of blood pulsations corresponding to each heartbeat of a patient. In fact, the "pulse" in pulse oximetry refers to the time varying amount of arterial blood in the tissue during each cardiac cycle.

[0008] Pulse oximeters typically utilize a non-invasive sensor that transmits light through a patient's tissue and that photoelectrically detects the absorption and/or scattering of the transmitted light in such tissue. One or more of the above physiological characteristics may then be calculated based upon the amount of light absorbed or scattered. More specifically, the light passed through the tissue is typically selected to be of one or more wavelengths that may be absorbed or scattered by the blood in an amount correlative to the amount of the blood constituent present in the blood. The amount of light absorbed and/or scattered may then be used to estimate the amount of blood constituent in the tissue using various algorithms.

[0009] Conventional pulse oximetry sensors are either disposable or reusable. In many instances, it may be desirable to employ, for cost and/or convenience, a reusable pulse oximeter sensor. Reusable sensors are typically semi-rigid or rigid devices that may be clipped to a patient. Unfortunately, reusable

sensors may be uncomfortable for the patient for various reasons. For example, sensors may have angled or protruding surfaces that, over time, may cause discomfort. In addition, reusable pulse oximeter sensors may pose other problems during use. For example, lack of a secure fit may allow light from the environment to reach the photodetecting elements of the sensor, thus causing inaccuracies in the resulting measurement.

[0010] Because pulse oximetry readings depend on pulsation of blood through the tissue, any event that interferes with the ability of the sensor to detect that pulsation can cause variability in these measurements. A reusable sensor should fit snugly enough that incidental patient motion will not dislodge or move the sensor, yet not so tight that normal blood flow to the tissue is disrupted. As sensors are worn for several hours at a time, an overly tight fit may cause local exsanguination of the tissue around the sensor. Exsanguinated tissue, which is devoid of blood, shunts the sensor light through the tissue, resulting in increased measurement errors.

### SUMMARY

[0011] Certain aspects commensurate in scope with the originally claimed invention are set forth below. It should be understood that these aspects are presented merely to provide the reader with a brief summary of certain forms that the invention might take and that these aspects are not intended to limit the scope of the invention. Indeed, the invention may encompass a variety of aspects that may not be set forth below.

[0012] There is provided a sensor that includes: a sensor body having a first portion and a second portion; a spring adapted to bias the first portion towards the second portion; a stopping element adapted to establish a minimum distance between the first portion and the second portion; and at least one sensing element disposed on the sensor body.

[0013] There is provided a sensor that includes: a sensor body having a first portion, a second portion; a spring adapted to bias the first portion towards the second; a substrate disposed on at least one of the first portion or the second portion, wherein the substrate is adapted to move with at least one degree of freedom relative to the sensor body; and at least one sensing element disposed on the substrate.

[0014] There is also provided a pulse oximetry system that includes: a pulse oximetry monitor and a pulse oximetry sensor adapted to be operatively coupled to the monitor, the sensor comprising: a sensor body having a first portion and a second portion; a spring adapted to bias the first portion towards the second portion; a stopping element adapted to establish a minimum distance between the first portion and the second portion; and at least one sensing element disposed on the sensor body.

[0015] There is also provided a method of operating a sensor that includes: biasing a first portion and a second portion of a sensor body towards one another with a spring; and establishing a minimum distance between the first portion and the second portion with a stopper disposed on the sensor body.

[0016] There is also provided a method of manufacturing a sensor that includes: providing a sensor body having a first portion and a second portion; providing a spring adapted to bias the first portion towards the second portion; providing a stopping element adapted to establish a minimum distance between the first portion and the second portion; and providing at least one sensing element disposed on the sensor body.

## BRIEF DESCRIPTION OF THE DRAWINGS

[0017] Advantages of the invention may become apparent upon reading the following detailed description and upon reference to the drawings in which:

[0018] FIG. 1A illustrates a perspective view of an exemplary sensor with a stopper and a flat spring according to the present invention;

[0019] FIG. 1B illustrates the sensor of FIG. 1A applied to a patient earlobe according to the present invention;

[0020] FIG. 2A illustrates a perspective view of an exemplary sensor with a rigid bar according to the present invention;

[0021] FIG. 2B illustrates a cross-sectional view of the open sensor of FIG. 2A;

[0022] FIG. 2C illustrates a cross-sectional view of the sensor of FIG. 2A applied to a patient's earlobe;

[0023] FIG. 2D illustrates a view of an exemplary sensor with an adjustable bar according to the present invention;

[0024] FIG. 3A illustrates a cross-sectional view of an open exemplary sensor with a stopper within a hinge according to the present invention;

[0025] FIG. 3B illustrates a cross-sectional view of the sensor of FIG. 3A applied to a patient's earlobe;

[0026] FIG. 4A illustrates a cross sectional view of an exemplary sensor with a strap according to the present invention;

[0027] FIG. 4B illustrates a cross-sectional view of the sensor of FIG. 4A applied to a patient's earlobe;

[0028] FIG. 4C illustrates a view of an alternative embodiment of the sensor of FIG. 4A;

[0029] FIG. 4D illustrates a view of an alternative embodiment of the sensor of FIG. 4A with an offset emitter and detector;

[0030] FIG. 5A illustrates a cross sectional view of an exemplary sensor with pivoting heads according to the present invention.

[0031] FIG. 5B illustrates a cross-sectional view of the sensor of FIG. 5A applied to a patient's earlobe; and

[0032] FIG. 6 illustrates a pulse oximetry system coupled to a multi-parameter patient monitor and a sensor according to embodiments of the present invention.

## DETAILED DESCRIPTION OF SPECIFIC EMBODIMENTS

[0033] One or more specific embodiments of the present invention will be described below. In an effort to provide a concise description of these embodiments, not all features of an actual implementation are described in the specification. It should be appreciated that in the development of any such actual implementation, as in any engineering or design project, numerous implementation-specific decisions must be made to achieve the developers' specific goals, such as compliance with system-related and business-related constraints, which may vary from one implementation to another. Moreover, it should be appreciated that such a development effort might be complex and time consuming, but would nevertheless be a routine undertaking of design, fabrication, and manufacture for those of ordinary skill having the benefit of this disclosure.

[0034] In accordance with the present technique, motion-resistant pulse oximetry sensors are provided that reduce measurement error by applying limited and uniform pressure to the optically probed tissue. A clip-style sensor for pulse

oximetry or other spectrophotometric uses is provided that has a compliant material disposed on the sensor to distribute the spring force of the clip to the tissue evenly when the sensor is applied to a patient. The clip-style sensor may also have a stopper that prevents the two portions of the clip from applying an excess of pressure to the patient's tissue. Alternatively, the clip-style sensor may allow the light emitting and detecting components of the sensor to tilt or otherwise move to accommodate the patient's tissue and to prevent overly tight gripping at the sensor placement site.

[0035] Pulse oximetry sensors are typically placed on a patient in a location that is normally perfused with arterial blood to facilitate measurement of the desired blood characteristics, such as arterial oxygen saturation measurement (SpO<sub>2</sub>). The most common sensor sites include a patient's fingertips, toes, earlobes, or forehead, and clip-style sensors are most commonly used on patient digits, earlobes, or nose bridges. Regardless of the placement of the sensor 10, the reliability of the pulse oximetry measurement is related to the accurate detection of transmitted light that has passed through the perfused tissue. Hence, a sensor 10 that fits a patient securely may reduce movement of the sensor and/or infiltration of light from outside sources into the sensor, which may lead to more accurate pulse oximetry measurements.

[0036] There are several factors that may influence the tightness with which a sensor may grip a patient's tissue. It is desirable to affix the sensor 10 to the patient in a manner that does not exsanguinate the tissue, but that provides sufficient pressure to squeeze out excess venous blood. Excess venous blood congestion in the optically probed tissue may influence the relationship between the modulation ratio of the time-varying light transmission signals of the wavelengths transmitted and SpO<sub>2</sub>. As venous blood has an increased concentration of deoxyhemoglobin as compared to arterial blood, its contribution to the pulse oximetry measurement may shift the wavelength of the detected light. Thus, the pulse oximetry sensor may measure a mixed arterial-venous oxygen saturation and detect differences in signal modulations unrelated to the underlying SpO<sub>2</sub> level. It is therefore desirable to reduce the contribution of excess venous blood to the pulse oximetry measurement by clipping a sensor to a patient's tissue with enough spring force to squeeze out excess venous blood.

[0037] On the other hand, a patient's tissue may suffer if clipped too tightly by a pulse oximetry sensor. In addition to causing patient discomfort, a sensor with excess gripping force in a hinge spring or other closing mechanism may squeeze both arterial and venous blood from a patient's tissue, causing the tissue to become exsanguinated. Light from a sensor's emitter that passes through such exsanguinated tissue may not be modulated by arterial blood, which may cause the resulting SpO<sub>2</sub> measurements to be artificially low. Thus, it is desirable to clip a sensor 10 to a patient's tissue tightly enough to reduce the amount of venous blood congestion, but not so tightly as to interfere with arterial blood perfusion.

[0038] In accordance with the present techniques, examples of clip-style sensors that apply limited, uniform pressure to a patient's tissue are disclosed. An exemplary sensor 10A adapted for use on a patient's earlobe is illustrated in FIG. 1A. The sensor has a first portion 12 and a second portion 14 that are applied to opposite sides of an earlobe. The sensor body 16 includes a flat spring 18 that may be used to

connect the first portion 12 and the second portion 14. The first portion 12 and the second portion 14 may have a rigid outer layer 20.

[0039] The sensor 10A may also include a stopper 22 that limits the distance that the first portion 12 and the second portion 14 may move towards one another. Generally, it is envisioned that the stopper 22 be configured to allow the first portion 12 to move towards the second portion 14 such that they are not able to move past a minimum distance from one another that permits the sensor 10A to securely grip a patient's tissue. Such a minimum distance may generally be determined by the desired sensor placement site (e.g. nose, earlobe, or digit) and the size of the patient (e.g. child or adult). As the sensor 10A is applied to the patient's earlobe 24, the stopper 22 absorbs part of the spring force of the flat spring 18 to prevent the sensor 10A from gripping the tissue so tightly as to cause exsanguinations or discomfort. The stopper 22 may be permanently attached to the sensor body 16, or may be removable.

[0040] In an alternate embodiment, FIG. 2A depicts a perspective side view of a sensor 10B with a permanently attached rigid bar 30 acting as a stopper between a first portion 32 and a second portion 34 of a sensor body 36. An emitter 26 is disposed on the first portion 32 and a detector 26 is disposed on the second portion 34. The rigid bar 30 is permanently attached to the first portion 32 and moves away from the second portion 34 during the opening of the sensor 10B, as shown in the cross-sectional view of the open sensor 10B in FIG. 2B. However, it should be understood that the rigid bar 30 may alternatively be disposed on the second portion 34 in other embodiments. The rigid bar 30 as depicted is disposed on the first portion 32 of the sensor 10B in a region of the sensor body 36 that is free of intervening tissue when the sensor 10B is applied an earlobe 38, as shown in FIG. 2C. As the sensor 10B is closed, the rigid bar 30 contacts the second portion 34 and prevents further biasing of the first portion 32 towards the second portion 34. The first portion 32 and the second portion 34 may be connected by a hinge 40 with a spring 42. Thus, the rigid bar 30 restricts the range of motion of the hinge 40, such that the hinge 40 may only move the first portion 32 and the second portion 34 toward one another to a certain degree. Thus, the maximum spring force applied to the tissue is limited because the rigid bar 30 limits the force that the first portion 32 and the second portion 34 may exert against the earlobe 38.

[0041] When the sensor 10B is applied to the patient's earlobe 38, as shown in FIG. 2C, a resilient pad 44 absorbs part of the force of the spring 42 and distributes the remaining spring force to the earlobe 38 along the tissue-contacting surface of the sensor 10B. Thus, the total compression resistance of the resilient material is generally less than the force of the spring 42. The resilient pad may be any shock-absorbing material, including foam, silicone, or rubber. The sensor 10B thereby evenly distributes a limited force to the patient's tissue through use of a resilient pad 44, which spreads the force along the tissue-contacting surface.

[0042] In an alternate embodiment, depicted in FIG. 2D, the sensor 10B may include an adjustable bar 31 that may be threaded through an opening (not shown) in the sensor body 36. Thus, the length of the adjustable bar 31 may be increased by threading more length of the adjustable bar 31 through the sensor body 36. In such an embodiment, the minimum distance between the first portion 32 and the second portion 34 may be increased to accommodate the tissue of larger

patients. Alternatively, smaller patients may require adjustment of the adjustable bar 31 such that more of the adjustable bar is threaded outside the sensor body 36 (i.e. not in the region between the first portion 32 and the second portion 34). Additionally, the sensor 10B may be applied to the patient, and a healthcare worker may adjust the length of the adjustable bar 31 until a desired amount of pressure on the tissue is achieved. In certain embodiments, the adjustable bar may be further secured by a nut 33 or other holding mechanism.

[0043] It is also envisioned that spring force of a hinge may be restricted by other mechanical structures. For example, in an alternative embodiment shown in FIG. 3A and FIG. 3B, a sensor 10C has a stopper 46 that is disposed within the mechanism of a hinge 48 to restrict rotational motion, thus preventing the hinge 48 from exerting maximum pressure to the tissue when sensor 10C is applied to a patient's earlobe 58. The stopper 46 may be a rigid material that is designed to mechanically block the motion of the hinge 48.

[0044] As depicted, the emitter 50 and the detector 52 are disposed on a thin substrate 54. The substrate 54 may be any suitable material, including plastic or woven cloth, and may be rigid or flexible. The substrate 54 may be disposed on the tissue-contacting side of a resilient pad 56. In certain embodiments, it may be advantageous to employ a flexible substrate 54, which may conform more closely to a patient's tissue when the sensor 10C is applied. In other embodiments, a more rigid substrate 54 may absorb more of the spring force of the hinge 48, and thus may prevent the sensor 10C from exerting excess pressure on the tissue.

[0045] Alternatively, as shown by the embodiment illustrated in FIGS. 4A-D, a sensor 10D may have a flexible but inelastic strap 60, such as a plastic or metal strap, disposed on the handle end 62 of the sensor body, connecting the first portion 64 and the second portion 66. When the sensor 10D is open, the strap 60 is slack. When the sensor 10D is closed, such as when the sensor 10D is applied to a patient, as shown in FIG. 4B, the strap 60 is drawn taut, thus preventing the hinge 68 from moving the first portion 64 and the second portion 66 closer than a distance dictated by the length of the strap 60.

[0046] As depicted, the sensor 10D has resilient pads 70 disposed on the tissue-contacting sides of the first portion 64 and the second portion 66 of a sensor. The use of a resilient pad 70 on both the first portion 64 and the second portion 66 provides greater compression resistance against the spring force of the hinge 68 than only a single resilient pad. Additionally, the spring force is evenly distributed along the tissue-contacting surface that holds both the emitter 72 and the detector 74 against the tissue. Thus, a sensor 10D may be used in conjunction with a relatively strong spring. This may be advantageous in situations in which an ambulatory patient may require the sensor 10D to fit securely enough to withstand dislodgement in response to everyday activity.

[0047] In an alternate embodiment, FIG. 4C illustrates a sensor 10D with an adjustable strap 61. The adjustable strap 61 may be threaded through an opening (not shown) in the sensor body. When an appropriate length of the adjustable strap is disposed between the first portion 64 and the second portion 66 to provide the desired pressure on a patient's tissue, the adjustable strap 61 may be held in place by a clamp 63. As more length of the adjustable strap 61 is released into the region between the first portion 64 and the second portion 66, the sensor 10D is able to close more tightly over the tissue. Alternatively, a healthcare worker may pull the adjustable

strap 61 through the sensor body such that the length of adjustable strap 61 between the first portion 64 and the second portion 66 is decreased, and as a result the sensor 10D would exert less pressure on the tissue.

[0048] Clip-style sensors as provided herein are often used on a patient's earlobes, which may have fewer vascular structures as compared to a digit. To maximize the transmission of light through well-perfused capillary structures, an alternative embodiment of the sensor 10D is depicted in which the emitter 72 and detector 74 are offset from each other, so that they are not directly opposite. This causes the light emitted by the emitter 72 to pass through more blood-perfused tissue to reach the detector 74. As such, the light has a greater opportunity to be modulated by arterial blood in a manner which relates to a blood constituent. FIG. 4D illustrates that the configuration of the sensor 10D provides a longer light transmission path through the tissue, as indicated by arrow 75.

[0049] FIG. 5A and FIG. 5B depict an embodiment of a sensor 10E in which part of the spring force of a hinge 76 is absorbed by pivoting heads 78, upon which an emitter 80 and a detector 82 are disposed. The pivoting heads 78 are disposed on a first portion 84 and a second portion 86 of the sensor 10E. The first portion 84 and the second portion 86 are connected by the hinge 76. Pivoting heads are disposed on the tissue-contacting side of the first portion 84 and the second portion 86. As FIG. 5B illustrates, the pivoting heads 78 may tilt relative to the sensor body 88 in order to accommodate the contours of the patient's tissue. In certain embodiments, the pivoting heads 78 may also include resilient pads (not shown) that distribute the spring force of the hinge 76 along the tissue-contacting surface of the sensor 10E. In other embodiments, the sensor 10E may also include a stopper or stopping mechanism as described herein.

[0050] In an alternate embodiment (not shown), an adhesive material is applied to the tissue-contacting surface of the sensor 10 to enhance the securing of the sensor 10 to the tissue. The use of an adhesive material may improve the contact of the sensor to the appendage, and limit the susceptibility to motion artifacts. In addition, the likelihood of a gap between the sensor body and the skin is avoided.

[0051] In certain embodiments, it is contemplated that the spring force of the hinge (e.g. 40, 48, 68, or 78) or other closing mechanism, such as a flat spring (e.g. flat spring 18), has sufficient pressure so that it exceeds the typical venous pressure of a patient, but does not exceed the diastolic arterial pressure. A sensor 10 that applies a pressure greater than the venous pressure will squeeze excess venous blood from the optically probed tissue, thus enhancing the sensitivity of the sensor to variations in the arterial blood signal. Since the pressure applied by the sensor is designed to be less than the arterial pressure, the application of pressure to the tissue does not interfere with the arterial pulse signal. Typical venous pressure, diastolic arterial pressure and systolic arterial pressure are less than 10-35 mmHg, 80 mmHg, and 120 mmHg, respectively. These pressures may vary because of the location of the vascular bed and the patient's condition. In certain embodiments, the sensor may be adjusted to overcome an average pressure of 15-30 mmHg. In other embodiments, low arterial diastolic blood pressure (about 30 mmHg) may occur in sick patients. In such embodiments, the sensor 10 may remove most of the venous pooling with light to moderate pressure (to overcome about 15 mmHg). It is contemplated that removing venous blood contribution without arterial blood exsanguination may improve the arterial pulse signal.

[0052] The exemplary sensors described above, illustrated generically as a sensor 10, may be used in conjunction with a pulse oximetry monitor 90, as illustrated in FIG. 6. It should be appreciated that the cable 92 of the sensor 10 may be coupled to the monitor 90 or it may be coupled to a transmission device (not shown) to facilitate wireless transmission between the sensor 10 and the monitor 90. The monitor 90 may be any suitable pulse oximeter, such as those available from Nellcor Puritan Bennett Inc. Furthermore, to upgrade conventional pulse oximetry provided by the monitor 90 to provide additional functions, the monitor 90 may be coupled to a multi-parameter patient monitor 94 via a cable 96 connected to a sensor input port or via a cable 98 connected to a digital communication port.

[0053] The sensor 10 includes an emitter 100 and a detector 102 that may be of any suitable type. For example, the emitter 100 may be one or more light emitting diodes adapted to transmit one or more wavelengths of light in the red to infrared range, and the detector 102 may be a photodetector selected to receive light in the range or ranges emitted from the emitter 100. For pulse oximetry applications using either transmission or reflectance type sensors, the oxygen saturation of the patient's arterial blood may be determined using two or more wavelengths of light, most commonly red and near infrared wavelengths. Similarly, in other applications, a tissue water fraction (or other body fluid related metric) or a concentration of one or more biochemical components in an aqueous environment may be measured using two or more wavelengths of light, most commonly near infrared wavelengths between about 1,000 nm to about 2,500 nm. It should be understood that, as used herein, the term "light" may refer to one or more of infrared, visible, ultraviolet, or even X-ray electromagnetic radiation, and may also include any wavelength within the infrared, visible, ultraviolet, or X-ray spectra.

[0054] The emitter 100 and the detector 102 may be disposed on a sensor body 104, which may be made of any suitable material, such as plastic, foam, woven material, or paper. Alternatively, the emitter 100 and the detector 102 may be remotely located and optically coupled to the sensor 10 using optical fibers. In the depicted embodiments, the sensor 10 is coupled to a cable 92 that is responsible for transmitting electrical and/or optical signals to and from the emitter 100 and detector 102 of the sensor 10. The cable 92 may be permanently coupled to the sensor 10, or it may be removably coupled to the sensor 10—the latter alternative being more useful and cost efficient in situations where the sensor 10 is disposable.

[0055] The sensor 10 may be a "transmission type" sensor. Transmission type sensors include an emitter 100 and detector 102 that are typically placed on opposing sides of the sensor site. If the sensor site is a fingertip, for example, the sensor 10 is positioned over the patient's fingertip such that the emitter 100 and detector 102 lie on either side of the patient's nail bed. In other words, the sensor 10 is positioned so that the emitter 100 is located on the patient's fingernail and the detector 102 is located 180° opposite the emitter 100 on the patient's finger pad. During operation, the emitter 100 shines one or more wavelengths of light through the patient's fingertip and the light received by the detector 102 is processed to determine various physiological characteristics of the patient. In each of the embodiments discussed herein, it should be understood that the locations of the emitter 100 and the detector 102 may be exchanged. For example, the detector

**102** may be located at the top of the finger and the emitter **100** may be located underneath the finger. In either arrangement, the sensor **10** will perform in substantially the same manner. **[0056]** Reflectance type sensors generally operate under the same general principles as transmittance type sensors. However, reflectance type sensors include an emitter **100** and detector **102** that are typically placed on the same side of the sensor site. For example, a reflectance type sensor may be placed on a patient's fingertip or forehead such that the emitter **100** and detector **102** lie side-by-side. Reflectance type sensors detect light photons that are scattered back to the detector **102**.

**[0057]** While the invention may be susceptible to various modifications and alternative forms, specific embodiments have been shown by way of example in the drawings and have been described in detail herein. However, it should be understood that the invention is not intended to be limited to the particular forms disclosed. Indeed, the present techniques may not only be applied to measurements of blood oxygen saturation, but these techniques may also be utilized for the measurement and/or analysis of other blood constituents using principles of pulse oximetry. Rather, the invention is to cover all modifications, equivalents, and alternatives falling within the spirit and scope of the invention as defined by the following appended claims.

What is claimed is:

1. A sensor adapted to be applied to a patient's tissue comprising:
  - a sensor body having a first portion and a second portion biased towards one another;
  - a first substrate disposed on the first portion;
  - a second substrate disposed on the second portion, wherein the first substrate and the second substrate are each configured to tilt relative to the sensor body; and
  - at least one sensing element disposed on at least one of the first substrate or the second substrate.
2. The sensor, as set forth in claim 1, wherein the first substrate and the second substrate are adapted to pivot on respective pins.
3. The sensor, as set forth in claim 1, wherein the first substrate is connected to the first portion by a hinge.
4. The sensor, as set forth in claim 1, wherein the sensor is adapted to apply a spring force to the patient's tissue adapted to overcome a blood pressure of about 35 mm Hg or less.
5. The sensor, as set forth in claim 1, further comprising a resilient material disposed on at least one of the first portion or the second portion.
6. The sensor, as set forth in claim 6, wherein the resilient material is disposed on one or both of the first substrate or the second substrate.

7. The sensor, as set forth in claim 6, wherein the resilient material comprises a foam.

8. The sensor, as set forth in claim 1, comprising an adhesive material disposed on at least one of the first substrate or the second substrate.

9. The sensor, as set forth in claim 1, wherein the sensing element comprises an emitter and a detector.

10. The sensor, as set forth in claim 9, wherein the emitter comprises a light-emitting diode and the detector comprises a photodetector.

11. The sensor, as set forth in claim 9, wherein the emitter is disposed on the first portion and the detector is disposed on the second portion such that the emitter and the detector are not opposite each other.

12. The sensor, as set forth in claim 1, wherein the sensor comprises at least one of a pulse oximetry sensor, a sensor for measuring a water fraction, or a combination thereof.

13. The sensor, as set forth in claim 1, comprising at least one integrated circuit device.

14. The sensor, as set forth in claim 1, comprising a cable comprising one or more integrated circuits.

15. A pulse oximetry system comprising:

- a pulse oximetry monitor; and
- a pulse oximetry sensor adapted to be operatively coupled to the monitor, the sensor comprising:
  - a sensor body having a first portion and a second portion biased towards one another;
  - a first substrate disposed on the first portion;
  - a second substrate disposed on the second portion, wherein the first substrate and the second substrate are each configured to tilt relative to the sensor body; and
  - at least one sensing element disposed on at least one of the first substrate or the second substrate.

16. The pulse oximetry system, as set forth in claim 15, wherein the sensing element comprises an emitter and wherein a detector is disposed on the second portion.

17. The pulse oximetry system, as set forth in claim 16, wherein detector is disposed on the second portion such that the emitter and the detector are not opposite each other.

18. The pulse oximetry system, as set forth in claim 15, wherein the sensor is configured to be applied to an ear.

19. The pulse oximetry system, as set forth in claim 15, wherein the sensor is configured to be applied to a finger.

20. The pulse oximetry system, as set forth in claim 15, wherein the sensor comprises a spring that biases the first portion and the second portion towards one another.

\* \* \* \* \*

专利名称(译)	夹式医疗传感器及其使用技术		
公开(公告)号	<a href="#">US20130303864A1</a>	公开(公告)日	2013-11-14
申请号	US13/868794	申请日	2013-04-23
[标]申请(专利权)人(译)	柯惠有限合伙公司		
申请(专利权)人(译)	COVIDIEN LP ,		
当前申请(专利权)人(译)	COVIDIEN LP		
[标]发明人	CHEN RODNEY P		
发明人	CHEN, RODNEY P.		
IPC分类号	A61B5/1455 A61B5/00		
CPC分类号	A61B5/14552 A61B5/443 A61B5/6816 A61B5/6819 A61B5/6826 A61B5/6838 A61B2090/034		
外部链接	<a href="#">Espacenet</a> <a href="#">USPTO</a>		

摘要(译)

夹式脉冲传感器可以适于向患者的组织施加有限的均匀压力。提供了一种夹式传感器，其通过向患者组织施加有限的均匀压力来减少运动伪影，从而减少组织放血。此外，这种传感器提供牢固的配合，同时避免佩戴者的不适。

