



US010271748B2

(12) **United States Patent**  
**Al-Ali**

(10) **Patent No.:** **US 10,271,748 B2**  
(45) **Date of Patent:** **\*Apr. 30, 2019**

(54) **PATIENT MONITOR FOR DETERMINING MICROCIRCULATION STATE**

*A61B 5/6801* (2013.01); *A61B 5/7275* (2013.01); *A61B 5/7282* (2013.01); *A61B 5/746* (2013.01)

(71) Applicant: **MASIMO CORPORATION**, Irvine, CA (US)

(58) **Field of Classification Search**  
None  
See application file for complete search history.

(72) Inventor: **Ammar Al-Ali**, San Juan Capistrano, CA (US)

(56) **References Cited**

(73) Assignee: **MASIMO CORPORATION**, Irvine, CA (US)

U.S. PATENT DOCUMENTS

(\*) Notice: Subject to any disclaimer, the term of this patent is extended or adjusted under 35 U.S.C. 154(b) by 30 days.

3,980,075 A 9/1976 Heule  
4,960,128 A 10/1990 Gordon et al.  
(Continued)

This patent is subject to a terminal disclaimer.

OTHER PUBLICATIONS

(21) Appl. No.: **15/709,189**

U.S. Appl. No. 15/797,839, Patient Monitor for Monitoring Microcirculation, filed Oct. 30, 2017.

(22) Filed: **Sep. 19, 2017**

*Primary Examiner* — Eric F Winakur  
*Assistant Examiner* — Marjan Fardanesh  
(74) *Attorney, Agent, or Firm* — Knobbe Martens Olson & Bear LLP

(65) **Prior Publication Data**

US 2018/0055385 A1 Mar. 1, 2018

**Related U.S. Application Data**

(63) Continuation of application No. 14/923,235, filed on Oct. 26, 2015, now Pat. No. 9,795,310, which is a (Continued)

(57) **ABSTRACT**

As placement of a physiological monitoring sensor is typically at a sensor site located at an extremity of the body, the state of microcirculation, such as whether vessels are blocked or open, can have a significant effect on the readings at the sensor site. It is therefore desirable to provide a patient monitor and/or physiological monitoring sensor capable of distinguishing the microcirculation state of blood vessels. In some embodiments, the patient monitor and/or sensor provide a warning and/or compensates a measurement based on the microcirculation state. In some embodiments, a microcirculation determination process implementable by the patient monitor and/or sensor is used to determine the state of microcirculation of the patient.

(51) **Int. Cl.**

*A61B 5/1455* (2006.01)  
*A61B 5/026* (2006.01)  
*A61B 5/024* (2006.01)  
*A61B 5/00* (2006.01)  
*A61B 5/02* (2006.01)

(52) **U.S. Cl.**

CPC ..... *A61B 5/0261* (2013.01); *A61B 5/02007* (2013.01); *A61B 5/02427* (2013.01); *A61B 5/14551* (2013.01); *A61B 5/14552* (2013.01);

**22 Claims, 7 Drawing Sheets**

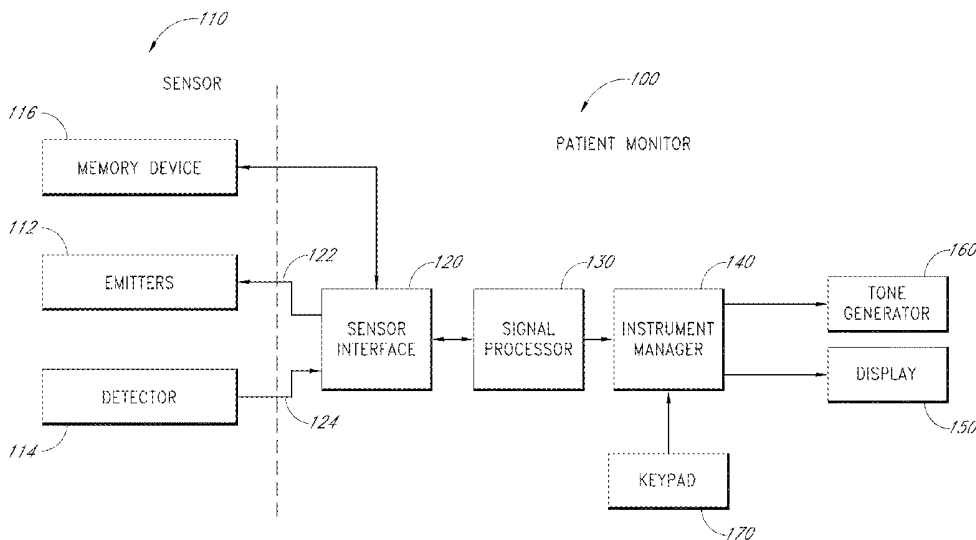

**Related U.S. Application Data**

continuation of application No. 14/160,316, filed on Jan. 21, 2014, now Pat. No. 9,192,312, which is a continuation of application No. 13/101,093, filed on May 4, 2011, now Pat. No. 8,666,468.

(60) Provisional application No. 61/332,155, filed on May 6, 2010.

(56)

**References Cited**

## U.S. PATENT DOCUMENTS

4,964,408 A	10/1990	Hink et al.	6,129,675 A	10/2000	Jay
5,041,187 A	8/1991	Hink et al.	6,144,868 A	11/2000	Parker
5,069,213 A	12/1991	Polczynski	6,151,516 A	11/2000	Kiani-Azarbayjany et al.
5,163,438 A	11/1992	Gordon et al.	6,152,754 A	11/2000	Gerhardt et al.
5,319,355 A	6/1994	Russek	6,157,850 A	12/2000	Diab et al.
5,337,744 A	8/1994	Branigan	6,165,005 A	12/2000	Mills et al.
5,341,805 A	8/1994	Stavridi et al.	6,184,521 B1	2/2001	Coffin, IV et al.
D353,195 S	12/1994	Savage et al.	6,206,830 B1	3/2001	Diab et al.
D353,196 S	12/1994	Savage et al.	6,229,856 B1	5/2001	Diab et al.
5,377,676 A	1/1995	Vari et al.	6,232,609 B1	5/2001	Snyder et al.
D359,546 S	6/1995	Savage et al.	6,236,872 B1	5/2001	Diab et al.
5,431,170 A	7/1995	Mathews	6,241,683 B1	6/2001	Macklem et al.
D361,840 S	8/1995	Savage et al.	6,253,097 B1	6/2001	Aronow et al.
D362,063 S	9/1995	Savage et al.	6,256,523 B1	7/2001	Diab et al.
5,452,717 A	9/1995	Branigan et al.	6,263,222 B1	7/2001	Diab et al.
D363,120 S	10/1995	Savage et al.	6,278,522 B1	8/2001	Lepper, Jr. et al.
5,456,252 A	10/1995	Vari et al.	6,280,213 B1	8/2001	Tobler et al.
5,479,934 A	1/1996	Imran	6,285,896 B1	9/2001	Tobler et al.
5,482,036 A	1/1996	Diab et al.	6,301,493 B1	10/2001	Marro et al.
5,490,505 A	2/1996	Diab et al.	6,308,089 B1	10/2001	von der Ruhr et al.
5,494,043 A	2/1996	O'Sullivan et al.	6,317,627 B1	11/2001	Ennen et al.
5,533,511 A	7/1996	Kaspari et al.	6,321,100 B1	11/2001	Parker
5,534,851 A	7/1996	Russek	6,325,761 B1	12/2001	Jay
5,561,275 A	10/1996	Savage et al.	6,334,065 B1	12/2001	Al-Ali et al.
5,562,002 A	10/1996	Lalin	6,343,224 B1	1/2002	Parker
5,590,649 A	1/1997	Caro et al.	6,349,228 B1	2/2002	Kiani et al.
5,602,924 A	2/1997	Durand et al.	6,360,114 B1	3/2002	Diab et al.
5,632,272 A	5/1997	Diab et al.	6,368,283 B1	4/2002	Xu et al.
5,638,816 A	6/1997	Kiani-Azarbayjany et al.	6,371,921 B1	4/2002	Caro et al.
5,638,818 A	6/1997	Diab et al.	6,377,829 B1	4/2002	Al-Ali
5,645,440 A	7/1997	Tobler et al.	6,388,240 B2	5/2002	Schulz et al.
5,685,299 A	11/1997	Diab et al.	6,397,091 B2	5/2002	Diab et al.
D393,830 S	4/1998	Tobler et al.	6,430,437 B1	8/2002	Marro
5,743,262 A	4/1998	Lepper, Jr. et al.	6,430,525 B1	8/2002	Weber et al.
5,758,644 A	6/1998	Diab et al.	6,463,311 B1	10/2002	Diab
5,760,910 A	6/1998	Lepper, Jr. et al.	6,470,199 B1	10/2002	Kopotic et al.
5,769,785 A	6/1998	Diab et al.	6,501,975 B2	12/2002	Diab et al.
5,782,757 A	7/1998	Diab et al.	6,505,059 B1	1/2003	Kollias et al.
5,785,659 A	7/1998	Caro et al.	6,515,273 B2	2/2003	Al-Ali
5,791,347 A	8/1998	Flaherty et al.	6,519,487 B1	2/2003	Parker
5,810,734 A	9/1998	Caro et al.	6,525,386 B1	2/2003	Mills et al.
5,823,950 A	10/1998	Diab et al.	6,526,300 B1	2/2003	Kiani et al.
5,830,131 A	11/1998	Caro et al.	6,541,756 B2	4/2003	Schulz et al.
5,833,618 A	11/1998	Caro et al.	6,542,764 B1	4/2003	Al-Ali et al.
5,860,919 A	1/1999	Kiani-Azarbayjany et al.	6,580,086 B1	6/2003	Schulz et al.
5,890,929 A	4/1999	Mills et al.	6,584,336 B1	6/2003	Ali et al.
5,904,654 A	5/1999	Wohltmann et al.	6,595,316 B2	7/2003	Cybulski et al.
5,919,134 A	7/1999	Diab	6,597,932 B2	7/2003	Tian et al.
5,934,925 A	8/1999	Tobler et al.	6,597,933 B2	7/2003	Kiani et al.
5,940,182 A	8/1999	Lepper, Jr. et al.	6,606,511 B1	8/2003	Ali et al.
5,987,343 A	11/1999	Kinast	6,632,181 B2	10/2003	Flaherty et al.
5,995,855 A	11/1999	Kiani et al.	6,639,668 B1	10/2003	Trepagnier
5,997,343 A	12/1999	Mills et al.	6,640,116 B2	10/2003	Diab
6,002,952 A	12/1999	Diab et al.	6,643,530 B2	11/2003	Diab et al.
6,011,986 A	1/2000	Diab et al.	6,650,917 B2	11/2003	Diab et al.
6,027,452 A	2/2000	Flaherty et al.	6,654,624 B2	11/2003	Diab et al.
6,036,642 A	3/2000	Diab et al.	6,658,276 B2	12/2003	Kiani et al.
6,045,509 A	4/2000	Caro et al.	6,661,161 B1	12/2003	Lanzo et al.
6,067,462 A	5/2000	Diab et al.	6,671,531 B2	12/2003	Al-Ali et al.
6,081,735 A	6/2000	Diab et al.	6,678,543 B2	1/2004	Diab et al.
6,088,607 A	7/2000	Diab et al.	6,684,090 B2	1/2004	Ali et al.
6,110,522 A	8/2000	Lepper, Jr. et al.	6,684,091 B2	1/2004	Parker
6,124,597 A	9/2000	Shehada	6,697,656 B1	2/2004	Al-Ali
6,128,521 A	10/2000	Marro et al.	6,697,657 B1	2/2004	Shehada et al.
			6,697,658 B2	2/2004	Al-Ali
			RE38,476 E	3/2004	Diab et al.
			6,699,194 B1	3/2004	Diab et al.
			6,714,804 B2	3/2004	Al-Ali et al.
			RE38,492 E	4/2004	Diab et al.
			6,721,582 B2	4/2004	Trepagnier et al.
			6,721,585 B1	4/2004	Parker
			6,725,075 B2	4/2004	Al-Ali
			6,728,560 B2	4/2004	Kollias et al.
			6,735,459 B2	5/2004	Parker
			6,745,060 B2	6/2004	Diab et al.
			6,760,607 B2	7/2004	Al-Ali
			6,770,028 B1	8/2004	Ali et al.
			6,771,994 B2	8/2004	Kiani et al.
			6,792,300 B1	9/2004	Diab et al.

(56)

## References Cited

## U.S. PATENT DOCUMENTS

6,813,511 B2	11/2004	Diab et al.	7,377,899 B2	5/2008	Weber et al.
6,816,741 B2	11/2004	Diab	7,383,070 B2	6/2008	Diab et al.
6,822,564 B2	11/2004	Al-Ali	7,415,297 B2	8/2008	Al-Ali et al.
6,826,419 B2	11/2004	Diab et al.	7,428,432 B2	9/2008	Ali et al.
6,830,711 B2	12/2004	Mills et al.	7,438,683 B2	10/2008	Al-Ali et al.
6,850,787 B2	2/2005	Weber et al.	7,440,787 B2	10/2008	Diab
6,850,788 B2	2/2005	Al-Ali	7,454,240 B2	11/2008	Diab et al.
6,852,083 B2	2/2005	Caro et al.	7,467,002 B2	12/2008	Weber et al.
6,861,639 B2	3/2005	Al-Ali	7,469,157 B2	12/2008	Diab et al.
6,898,452 B2	5/2005	Al-Ali et al.	7,471,969 B2	12/2008	Diab et al.
6,920,345 B2	7/2005	Al-Ali et al.	7,471,971 B2	12/2008	Diab et al.
6,931,268 B1	8/2005	Kiani-Azarbayjany et al.	7,483,729 B2	1/2009	Al-Ali et al.
6,934,570 B2	8/2005	Kiani et al.	7,483,730 B2	1/2009	Diab et al.
6,939,305 B2	9/2005	Flaherty et al.	7,489,958 B2	2/2009	Diab et al.
6,943,348 B1	9/2005	Coffin, IV	7,496,391 B2	2/2009	Diab et al.
6,950,687 B2	9/2005	Al-Ali	7,496,393 B2	2/2009	Diab et al.
6,961,598 B2	11/2005	Diab	D587,657 S	3/2009	Al-Ali et al.
6,970,792 B1	11/2005	Diab	7,499,741 B2	3/2009	Diab et al.
6,979,812 B2	12/2005	Al-Ali	7,499,835 B2	3/2009	Weber et al.
6,985,764 B2	1/2006	Mason et al.	7,500,950 B2	3/2009	Al-Ali et al.
6,993,371 B2	1/2006	Kiani et al.	7,509,154 B2	3/2009	Diab et al.
6,996,427 B2	2/2006	Ali et al.	7,509,494 B2	3/2009	Al-Ali
6,999,904 B2	2/2006	Weber et al.	7,510,849 B2	3/2009	Schurman et al.
7,003,338 B2	2/2006	Weber et al.	7,526,328 B2	4/2009	Diab et al.
7,003,339 B2	2/2006	Diab et al.	7,530,942 B1	5/2009	Diab
7,015,451 B2	3/2006	Dalke et al.	7,530,949 B2	5/2009	Al Ali et al.
7,024,233 B2	4/2006	Ali et al.	7,530,955 B2	5/2009	Diab et al.
7,027,849 B2	4/2006	Al-Ali	7,563,110 B2	7/2009	Al-Ali et al.
7,030,749 B2	4/2006	Al-Ali	7,596,398 B2	9/2009	Al-Ali et al.
7,039,449 B2	5/2006	Al-Ali	7,618,375 B2	11/2009	Flaherty
7,041,060 B2	5/2006	Flaherty et al.	D606,659 S	12/2009	Kiani et al.
7,044,918 B2	5/2006	Diab	7,647,083 B2	1/2010	Al-Ali et al.
7,048,687 B1	5/2006	Reuss et al.	D609,193 S	2/2010	Al-Ali et al.
7,067,893 B2	6/2006	Mills et al.	D614,305 S	4/2010	Al-Ali et al.
7,096,052 B2	8/2006	Mason et al.	RE41,317 E	5/2010	Parker
7,096,054 B2	8/2006	Abdul-Hafiz et al.	7,729,733 B2	6/2010	Al-Ali et al.
7,132,641 B2	11/2006	Schulz et al.	7,734,320 B2	6/2010	Al-Ali
7,142,901 B2	11/2006	Kiani et al.	7,761,127 B2	7/2010	Al-Ali et al.
7,149,561 B2	12/2006	Diab	7,761,128 B2	7/2010	Al-Ali et al.
7,186,966 B2	3/2007	Al-Ali	7,764,982 B2	7/2010	Dalke et al.
7,190,261 B2	3/2007	Al-Ali	D621,516 S	8/2010	Kiani et al.
7,215,984 B2	5/2007	Diab	7,791,155 B2	9/2010	Diab
7,215,986 B2	5/2007	Diab	7,801,581 B2	9/2010	Diab
7,221,971 B2	5/2007	Diab	7,822,452 B2	10/2010	Schurman et al.
7,225,006 B2	5/2007	Al-Ali et al.	RE41,912 E	11/2010	Parker
7,225,007 B2	5/2007	Al-Ali	7,844,313 B2	11/2010	Kiani et al.
RE39,672 E	6/2007	Shehada et al.	7,844,314 B2	11/2010	Al-Ali
7,239,905 B2	7/2007	Kiani-Azarbayjany et al.	7,844,315 B2	11/2010	Al-Ali
7,245,953 B1	7/2007	Parker	7,865,222 B2	1/2011	Weber et al.
7,254,429 B2	8/2007	Schurman et al.	7,873,497 B2	1/2011	Weber et al.
7,254,431 B2	8/2007	Al-Ali	7,880,606 B2	2/2011	Al-Ali
7,254,433 B2	8/2007	Diab et al.	7,880,626 B2	2/2011	Al-Ali et al.
7,254,434 B2	8/2007	Schulz et al.	7,891,355 B2	2/2011	Al-Ali et al.
7,272,425 B2	9/2007	Al-Ali	7,894,868 B2	2/2011	Al-Ali et al.
7,274,955 B2	9/2007	Kiani et al.	7,899,507 B2	3/2011	Al-Ali et al.
D554,263 S	10/2007	Al-Ali	7,899,518 B2	3/2011	Trepagnier et al.
7,280,858 B2	10/2007	Al-Ali et al.	7,904,132 B2	3/2011	Weber et al.
7,289,835 B2	10/2007	Mansfield et al.	7,909,772 B2	3/2011	Popov et al.
7,292,883 B2	11/2007	De Felice et al.	7,910,875 B2	3/2011	Al-Ali
7,295,866 B2	11/2007	Al-Ali	7,919,713 B2	4/2011	Al-Ali et al.
7,328,053 B1	2/2008	Diab et al.	7,937,128 B2	5/2011	Al-Ali
7,332,784 B2	2/2008	Mills et al.	7,937,129 B2	5/2011	Mason et al.
7,338,447 B2	3/2008	Phillips	7,937,130 B2	5/2011	Diab et al.
7,340,287 B2	3/2008	Mason et al.	7,941,199 B2	5/2011	Kiani
7,341,559 B2	3/2008	Schulz et al.	7,951,086 B2	5/2011	Flaherty et al.
7,341,562 B2	3/2008	Pless et al.	7,957,780 B2	6/2011	Lamego et al.
7,343,186 B2	3/2008	Lamego et al.	7,962,188 B2	6/2011	Kiani et al.
D566,282 S	4/2008	Al-Ali et al.	7,962,190 B1	6/2011	Diab et al.
7,355,512 B1	4/2008	Al-Ali	7,976,472 B2	7/2011	Kiani
7,356,365 B2	4/2008	Schurman	7,988,637 B2	8/2011	Diab
7,371,981 B2	5/2008	Abdul-Hafiz	7,990,382 B2	8/2011	Kiani
7,373,193 B2	5/2008	Al-Ali et al.	7,991,446 B2	8/2011	Al-Ali et al.
7,373,194 B2	5/2008	Weber et al.	8,000,761 B2	8/2011	Al-Ali
7,376,453 B1	5/2008	Diab et al.	8,008,088 B2	8/2011	Bellott et al.
7,377,794 B2	5/2008	Al Ali et al.	RE42,753 E	9/2011	Kiani-Azarbayjany et al.
			8,019,400 B2	9/2011	Diab et al.
			8,028,701 B2	10/2011	Al-Ali et al.
			8,029,765 B2	10/2011	Bellott et al.
			8,036,727 B2	10/2011	Schurman et al.

(56)

## References Cited

## U.S. PATENT DOCUMENTS

8,036,728 B2	10/2011	Diab et al.	8,532,727 B2	9/2013	Ali et al.
8,046,040 B2	10/2011	Ali et al.	8,532,728 B2	9/2013	Diab et al.
8,046,041 B2	10/2011	Diab et al.	D692,145 S	10/2013	Al-Ali et al.
8,046,042 B2	10/2011	Diab et al.	8,547,209 B2	10/2013	Kiani et al.
8,048,040 B2	11/2011	Kiani	8,548,548 B2	10/2013	Al-Ali
8,050,728 B2	11/2011	Al-Ali et al.	8,548,549 B2	10/2013	Schurman et al.
RE43,169 E	2/2012	Parker	8,548,550 B2	10/2013	Al-Ali et al.
8,118,620 B2	2/2012	Al-Ali et al.	8,560,032 B2	10/2013	Al-Ali et al.
8,126,528 B2	2/2012	Diab et al.	8,560,034 B1	10/2013	Diab et al.
8,128,572 B2	3/2012	Diab et al.	8,570,167 B2	10/2013	Al-Ali
8,130,105 B2	3/2012	Al-Ali et al.	8,570,503 B2	10/2013	Vo et al.
8,145,287 B2	3/2012	Diab et al.	8,571,617 B2	10/2013	Reichgott et al.
8,150,487 B2	4/2012	Diab et al.	8,571,618 B1	10/2013	Lamego et al.
8,175,672 B2	5/2012	Parker	8,571,619 B2	10/2013	Al-Ali et al.
8,180,420 B2	5/2012	Diab et al.	8,577,431 B2	11/2013	Lamego et al.
8,182,443 B1	5/2012	Kiani	8,581,732 B2	11/2013	Al-Ali et al.
8,185,180 B2	5/2012	Diab et al.	8,584,345 B2	11/2013	Al-Ali et al.
8,190,223 B2	5/2012	Al-Ali et al.	8,588,880 B2	11/2013	Abdul-Hafiz et al.
8,190,227 B2	5/2012	Diab et al.	8,600,467 B2	12/2013	Al-Ali et al.
8,203,438 B2	6/2012	Kiani et al.	8,606,342 B2	12/2013	Diab
8,203,704 B2	6/2012	Merritt et al.	8,626,255 B2	1/2014	Al-Ali et al.
8,204,566 B2	6/2012	Schurman et al.	8,630,691 B2	1/2014	Lamego et al.
8,219,172 B2	7/2012	Schurman et al.	8,634,889 B2	1/2014	Al-Ali et al.
8,224,411 B2	7/2012	Al-Ali et al.	8,641,631 B2	2/2014	Sierra et al.
8,228,181 B2	7/2012	Al-Ali	8,652,060 B2	2/2014	Al-Ali
8,229,533 B2	7/2012	Diab et al.	8,663,107 B2	3/2014	Kiani
8,233,955 B2	7/2012	Al-Ali et al.	8,666,468 B1	3/2014	Al-Ali
8,244,325 B2	8/2012	Al-Ali et al.	8,667,967 B2	3/2014	Al-Ali et al.
8,255,026 B1	8/2012	Al-Ali	8,670,811 B2	3/2014	O'Reilly
8,255,027 B2	8/2012	Al-Ali et al.	8,670,814 B2	3/2014	Diab et al.
8,255,028 B2	8/2012	Al-Ali et al.	8,676,286 B2	3/2014	Weber et al.
8,260,577 B2	9/2012	Weber et al.	8,682,407 B2	3/2014	Al-Ali
8,265,723 B1	9/2012	McHale et al.	RE44,823 E	4/2014	Parker
8,274,360 B2	9/2012	Sampath et al.	RE44,875 E	4/2014	Kiani et al.
8,280,473 B2	10/2012	Al-Ali	8,690,799 B2	4/2014	Telfort et al.
8,301,217 B2	10/2012	Al-Ali et al.	8,700,112 B2	4/2014	Kiani
8,306,596 B2	11/2012	Schurman et al.	8,702,627 B2	4/2014	Telfort et al.
8,310,336 B2	11/2012	Muhsin et al.	8,706,179 B2	4/2014	Parker
8,315,683 B2	11/2012	Al-Ali et al.	8,712,494 B1	4/2014	MacNeish, III et al.
RE43,860 E	12/2012	Parker	8,715,206 B2	5/2014	Telfort et al.
8,337,403 B2	12/2012	Al-Ali et al.	8,718,735 B2	5/2014	Lamego et al.
8,346,330 B2	1/2013	Lamego	8,718,737 B2	5/2014	Diab et al.
8,353,842 B2	1/2013	Al-Ali et al.	8,718,738 B2	5/2014	Blank et al.
8,355,766 B2	1/2013	MacNeish, III et al.	8,720,249 B2	5/2014	Al-Ali
8,359,080 B2	1/2013	Diab et al.	8,721,541 B2	5/2014	Al-Ali et al.
8,364,223 B2	1/2013	Al-Ali et al.	8,721,542 B2	5/2014	Al-Ali et al.
8,364,226 B2	1/2013	Diab et al.	8,723,677 B1	5/2014	Kiani
8,374,665 B2	2/2013	Lamego	8,740,792 B1	6/2014	Kiani et al.
8,385,995 B2	2/2013	Al-Ali et al.	8,754,776 B2	6/2014	Poeze et al.
8,385,996 B2	2/2013	Smith et al.	8,755,535 B2	6/2014	Telfort et al.
8,388,353 B2	3/2013	Kiani et al.	8,755,856 B2	6/2014	Diab et al.
8,399,822 B2	3/2013	Al-Ali	8,755,872 B1	6/2014	Marinow
8,401,602 B2	3/2013	Kiani	8,761,850 B2	6/2014	Lamego
8,405,608 B2	3/2013	Al-Ali et al.	8,764,671 B2	7/2014	Kiani
8,414,499 B2	4/2013	Al-Ali et al.	8,768,423 B2	7/2014	Shakespeare et al.
8,418,524 B2	4/2013	Al-Ali	8,771,204 B2	7/2014	Telfort et al.
8,423,106 B2	4/2013	Lamego et al.	8,777,634 B2	7/2014	Kiani et al.
8,428,967 B2	4/2013	Olsen et al.	8,781,543 B2	7/2014	Diab et al.
8,430,817 B1	4/2013	Al-Ali et al.	8,781,544 B2	7/2014	Al-Ali et al.
8,437,825 B2	5/2013	Dalvi et al.	8,781,549 B2	7/2014	Al-Ali et al.
8,455,290 B2	6/2013	Siskavich	8,788,003 B2	7/2014	Schurman et al.
8,457,703 B2	6/2013	Al-Ali	8,790,268 B2	7/2014	Al-Ali
8,457,707 B2	6/2013	Kiani	8,801,613 B2	8/2014	Al-Ali et al.
8,463,349 B2	6/2013	Diab et al.	8,821,397 B2	9/2014	Al-Ali et al.
8,466,286 B2	6/2013	Bellot et al.	8,821,415 B2	9/2014	Al-Ali et al.
8,471,713 B2	6/2013	Poeze et al.	8,830,449 B1	9/2014	Lamego et al.
8,473,020 B2	6/2013	Kiani et al.	8,831,700 B2	9/2014	Schurman et al.
8,483,787 B2	7/2013	Al-Ali et al.	8,840,549 B2	9/2014	Al-Ali et al.
8,489,364 B2	7/2013	Weber et al.	8,847,740 B2	9/2014	Kiani et al.
8,498,684 B2	7/2013	Weber et al.	8,849,365 B2	9/2014	Smith et al.
8,504,128 B2	8/2013	Blank et al.	8,852,094 B2	10/2014	Al-Ali et al.
8,509,867 B2	8/2013	Workman et al.	8,852,994 B2	10/2014	Wojtczuk et al.
8,515,509 B2	8/2013	Bruinsma et al.	8,868,147 B2	10/2014	Stippick et al.
8,523,781 B2	9/2013	Al-Ali	8,868,150 B2	10/2014	Al-Ali et al.
8,529,301 B2	9/2013	Al-Ali et al.	8,870,792 B2	10/2014	Al-Ali et al.
			8,886,271 B2	11/2014	Kiani et al.
			8,888,539 B2	11/2014	Al-Ali et al.
			8,888,708 B2	11/2014	Diab et al.
			8,892,180 B2	11/2014	Weber et al.

(56)

## References Cited

## U.S. PATENT DOCUMENTS

8,897,847	B2	11/2014	Al-Ali	9,375,185	B2	6/2016	Ali et al.
8,909,310	B2	12/2014	Lamego et al.	9,386,953	B2	7/2016	Al-Ali
8,911,377	B2	12/2014	Al-Ali	9,386,961	B2	7/2016	Al-Ali et al.
8,912,909	B2	12/2014	Al-Ali et al.	9,392,945	B2	7/2016	Al-Ali et al.
8,920,317	B2	12/2014	Al-Ali et al.	9,397,448	B2	7/2016	Al-Ali et al.
8,921,699	B2	12/2014	Al-Ali et al.	9,408,542	B1	8/2016	Kinast et al.
8,922,382	B2	12/2014	Al-Ali et al.	9,436,645	B2	9/2016	Al-Ali et al.
8,929,964	B2	1/2015	Al-Ali et al.	9,445,759	B1	9/2016	Lamego et al.
8,942,777	B2	1/2015	Diab et al.	9,466,919	B2	10/2016	Kiani et al.
8,948,834	B2	2/2015	Diab et al.	9,474,474	B2	10/2016	Lamego et al.
8,948,835	B2	2/2015	Diab	9,480,422	B2	11/2016	Al-Ali
8,965,471	B2	2/2015	Lamego	9,480,435	B2	11/2016	Olsen
8,983,564	B2	3/2015	Al-Ali	9,492,110	B2	11/2016	Al-Ali et al.
8,989,831	B2	3/2015	Al-Ali et al.	9,510,779	B2	12/2016	Poeze et al.
8,996,085	B2	3/2015	Kiani et al.	9,517,024	B2	12/2016	Kiani et al.
8,998,809	B2	4/2015	Kiani	9,532,722	B2	1/2017	Lamego et al.
9,028,429	B2	5/2015	Telfort et al.	9,538,949	B2	1/2017	Al-Ali et al.
9,037,207	B2	5/2015	Al-Ali et al.	9,538,980	B2	1/2017	Telfort et al.
9,060,721	B2	6/2015	Reichgott et al.	9,549,696	B2	1/2017	Lamego et al.
9,066,666	B2	6/2015	Kiani	9,554,737	B2	1/2017	Schurman et al.
9,066,680	B1	6/2015	Al-Ali et al.	9,560,996	B2	2/2017	Kiani
9,072,474	B2	7/2015	Al-Ali et al.	9,560,998	B2	2/2017	Al-Ali et al.
9,078,560	B2	7/2015	Schurman et al.	9,566,019	B2	2/2017	Al-Ali et al.
9,084,569	B2	7/2015	Weber et al.	9,579,039	B2	2/2017	Jansen et al.
9,095,316	B2	8/2015	Welch et al.	9,591,975	B2	3/2017	Dalvi et al.
9,106,038	B2	8/2015	Telfort et al.	9,622,692	B2	4/2017	Lamego et al.
9,107,625	B2	8/2015	Telfort et al.	9,622,693	B2	4/2017	Diab
9,107,626	B2	8/2015	Al-Ali et al.	D788,312	S	5/2017	Al-Ali et al.
9,113,831	B2	8/2015	Al-Ali	9,636,055	B2	5/2017	Al-Ali et al.
9,113,832	B2	8/2015	Al-Ali	9,636,056	B2	5/2017	Al-Ali
9,119,595	B2	9/2015	Lamego	9,649,054	B2	5/2017	Lamego et al.
9,131,881	B2	9/2015	Diab et al.	9,662,052	B2	5/2017	Al-Ali et al.
9,131,882	B2	9/2015	Al-Ali et al.	9,668,679	B2	6/2017	Schurman et al.
9,131,883	B2	9/2015	Al-Ali	9,668,680	B2	6/2017	Bruinsma et al.
9,131,917	B2	9/2015	Telfort et al.	9,668,703	B2	6/2017	Al-Ali
9,138,180	B1	9/2015	Coverston et al.	9,675,286	B2	6/2017	Diab
9,138,182	B2	9/2015	Al-Ali et al.	9,687,160	B2	6/2017	Kiani
9,138,192	B2	9/2015	Weber et al.	9,693,719	B2	7/2017	Al-Ali et al.
9,142,117	B2	9/2015	Muhsin et al.	9,693,737	B2	7/2017	Al-Ali
9,153,112	B1	10/2015	Kiani et al.	9,697,928	B2	7/2017	Al-Ali et al.
9,153,121	B2	10/2015	Kiani et al.	9,717,425	B2	8/2017	Kiani et al.
9,161,696	B2	10/2015	Al-Ali et al.	9,717,458	B2	8/2017	Lamego et al.
9,161,713	B2	10/2015	Al-Ali et al.	9,724,016	B1	8/2017	Al-Ali et al.
9,167,995	B2	10/2015	Lamego et al.	9,724,024	B2	8/2017	Al-Ali
9,176,141	B2	11/2015	Al-Ali et al.	9,724,025	B1	8/2017	Kiani et al.
9,186,102	B2	11/2015	Bruinsma et al.	9,730,640	B2	8/2017	Diab et al.
9,192,312	B2	11/2015	Al-Ali	9,743,887	B2	8/2017	Al-Ali et al.
9,192,329	B2	11/2015	Al-Ali	9,749,232	B2	8/2017	Sampath et al.
9,192,351	B1	11/2015	Telfort et al.	9,750,442	B2	9/2017	Olsen
9,195,385	B2	11/2015	Al-Ali et al.	9,750,443	B2	9/2017	Smith et al.
9,211,072	B2	12/2015	Kiani	9,750,461	B1	9/2017	Telfort
9,211,095	B1	12/2015	Al-Ali	9,775,545	B2	10/2017	Al-Ali et al.
9,218,454	B2	12/2015	Kiani et al.	9,775,546	B2	10/2017	Diab et al.
9,226,696	B2	1/2016	Kiani	9,775,570	B2	10/2017	Al-Ali
9,241,662	B2	1/2016	Al-Ali et al.	9,778,079	B1	10/2017	Al-Ali et al.
9,245,668	B1	1/2016	Vo et al.	9,782,077	B2	10/2017	Lamego et al.
9,259,185	B2	2/2016	Abdul-Hafiz et al.	9,782,110	B2	10/2017	Kiani
9,267,572	B2	2/2016	Barker et al.	9,787,568	B2	10/2017	Lamego et al.
9,277,880	B2	3/2016	Poeze et al.	9,788,735	B2	10/2017	Al-Ali
9,289,167	B2	3/2016	Diab et al.	9,788,768	B2	10/2017	Al-Ali et al.
9,295,421	B2	3/2016	Kiani et al.	9,795,300	B2	10/2017	Al-Ali
9,307,928	B1	4/2016	Al-Ali et al.	9,795,310	B2	10/2017	Al-Ali
9,323,894	B2	4/2016	Kiani	9,795,358	B2	10/2017	Telfort et al.
D755,392	S	5/2016	Hwang et al.	9,795,739	B2	10/2017	Al-Ali et al.
9,326,712	B1	5/2016	Kiani	9,801,556	B2	10/2017	Kiani
9,333,316	B2	5/2016	Kiani	9,801,588	B2	10/2017	Weber et al.
9,339,220	B2	5/2016	Lamego et al.	9,808,188	B1	11/2017	Perea et al.
9,341,565	B2	5/2016	Lamego et al.	2003/0069489	A1	4/2003	Abreu
9,351,673	B2	5/2016	Diab et al.	2005/0171438	A1	8/2005	Chen et al.
9,351,675	B2	5/2016	Al-Ali et al.	2006/0161054	A1	7/2006	Reuss et al.
9,364,181	B2	6/2016	Kiani et al.	2007/0282478	A1	12/2007	Al-Ali et al.
9,368,671	B2	6/2016	Wojtczuk et al.	2009/0143655	A1	6/2009	Shani
9,370,325	B2	6/2016	Al-Ali et al.	2009/0247984	A1	10/2009	Lamego et al.
9,370,326	B2	6/2016	McHale et al.	2009/0275813	A1	11/2009	Davis
9,370,335	B2	6/2016	Al-Ali et al.	2009/0275844	A1	11/2009	Al-Ali
				2010/0004518	A1	1/2010	Vo et al.
				2010/0030040	A1	2/2010	Poeze et al.
				2011/0082711	A1	4/2011	Poeze et al.
				2011/0105854	A1	5/2011	Kiani et al.

(56)

## References Cited

## U.S. PATENT DOCUMENTS

2011/0125060	A1	5/2011	Telfort et al.	2015/0165312	A1	6/2015	Kiani
2011/0208015	A1	8/2011	Welch et al.	2015/0196237	A1	7/2015	Lamego
2011/0230733	A1	9/2011	Al-Ali	2015/0196249	A1	7/2015	Brown et al.
2011/0237969	A1	9/2011	Eckerbom et al.	2015/0216459	A1	8/2015	Al-Ali et al.
2012/0046557	A1	2/2012	Kiani	2015/0230755	A1	8/2015	Al-Ali et al.
2012/0165629	A1	6/2012	Merritt et al.	2015/0238722	A1	8/2015	Al-Ali
2012/0209082	A1	8/2012	Al-Ali	2015/0245773	A1	9/2015	Lamego et al.
2012/0209084	A1	8/2012	Olsen et al.	2015/0245794	A1	9/2015	Al-Ali
2012/0283524	A1	11/2012	Kiani et al.	2015/0257689	A1	9/2015	Al-Ali et al.
2012/0319816	A1	12/2012	Al-Ali	2015/0272514	A1	10/2015	Kiani et al.
2013/0023775	A1	1/2013	Lamego et al.	2015/0351697	A1	12/2015	Weber et al.
2013/0041591	A1	2/2013	Lamego	2015/0351704	A1	12/2015	Kiani et al.
2013/0060147	A1	3/2013	Welch et al.	2015/0359429	A1	12/2015	Al-Ali et al.
2013/0096405	A1	4/2013	Garfio	2015/0366507	A1	12/2015	Blank
2013/0096936	A1	4/2013	Sampath et al.	2015/0380875	A1	12/2015	Coverston et al.
2013/0243021	A1	9/2013	Siskavich	2016/0029932	A1	2/2016	Al-Ali
2013/0253334	A1	9/2013	Al-Ali et al.	2016/0051205	A1	2/2016	Al-Ali et al.
2013/0267804	A1	10/2013	Al-Ali	2016/0058347	A1	3/2016	Reichgott et al.
2013/0296672	A1	11/2013	O'Neil et al.	2016/0066823	A1	3/2016	Al-Ali et al.
2013/0296713	A1	11/2013	Al-Ali et al.	2016/0066824	A1	3/2016	Al-Ali et al.
2013/0324808	A1	12/2013	Al-Ali et al.	2016/0072429	A1	3/2016	Kiani et al.
2013/0331660	A1	12/2013	Al-Ali et al.	2016/0081552	A1	3/2016	Wojtczuk et al.
2014/0012100	A1	1/2014	Al-Ali et al.	2016/0095543	A1	4/2016	Telfort et al.
2014/0051953	A1	2/2014	Lamego et al.	2016/0095548	A1	4/2016	Al-Ali et al.
2014/0081100	A1	3/2014	Muhsin et al.	2016/0103598	A1	4/2016	Al-Ali et al.
2014/0081175	A1	3/2014	Telfort	2016/0143548	A1	5/2016	Al-Ali
2014/0120564	A1	5/2014	Workman et al.	2016/0166182	A1	6/2016	Al-Ali et al.
2014/0121482	A1	5/2014	Merritt et al.	2016/0166183	A1	6/2016	Poeze et al.
2014/0127137	A1	5/2014	Bellott et al.	2016/0192869	A1	7/2016	Kiani et al.
2014/0135588	A1	5/2014	Al-Ali et al.	2016/0196388	A1	7/2016	Lamego
2014/0163344	A1	6/2014	Al-Ali	2016/0197436	A1	7/2016	Barker et al.
2014/0163402	A1	6/2014	Lamego et al.	2016/0213281	A1	7/2016	Eckerbom et al.
2014/0166076	A1	6/2014	Kiani et al.	2016/0228043	A1	8/2016	O'Neil et al.
2014/0171763	A1	6/2014	Diab	2016/0233632	A1	8/2016	Scruggs et al.
2014/0180038	A1	6/2014	Kiani	2016/0234944	A1	8/2016	Schmidt et al.
2014/0180154	A1	6/2014	Sierra et al.	2016/0270735	A1	9/2016	Diab et al.
2014/0180160	A1	6/2014	Brown et al.	2016/0283665	A1	9/2016	Sampath et al.
2014/0187973	A1	7/2014	Brown et al.	2016/0287090	A1	10/2016	Al-Ali et al.
2014/0213864	A1	7/2014	Abdul-Hafiz et al.	2016/0287786	A1	10/2016	Kiani
2014/0266790	A1	9/2014	Al-Ali et al.	2016/0296169	A1	10/2016	McHale et al.
2014/0275808	A1	9/2014	Poeze et al.	2016/0310052	A1	10/2016	Al-Ali et al.
2014/0275835	A1	9/2014	Lamego et al.	2016/0314260	A1	10/2016	Kiani
2014/0275871	A1	9/2014	Lamego et al.	2016/0324486	A1	11/2016	Al-Ali et al.
2014/0275872	A1	9/2014	Merritt et al.	2016/0324488	A1	11/2016	Olsen
2014/0276115	A1	9/2014	Dalvi et al.	2016/0327984	A1	11/2016	Al-Ali et al.
2014/0288400	A1	9/2014	Diab et al.	2016/0328528	A1	11/2016	Al-Ali et al.
2014/0316217	A1	10/2014	Purdon et al.	2016/0331332	A1	11/2016	Al-Ali
2014/0316218	A1	10/2014	Purdon et al.	2016/0367173	A1	12/2016	Dalvi et al.
2014/0316228	A1	10/2014	Blank et al.	2017/0000394	A1	1/2017	Al-Ali et al.
2014/0323825	A1	10/2014	Al-Ali et al.	2017/0007134	A1	1/2017	Al-Ali et al.
2014/0323897	A1	10/2014	Brown et al.	2017/0007190	A1	1/2017	Al-Ali et al.
2014/0323898	A1	10/2014	Purdon et al.	2017/0007198	A1	1/2017	Al-Ali et al.
2014/0330092	A1	11/2014	Al-Ali et al.	2017/0014083	A1	1/2017	Diab et al.
2014/0330098	A1	11/2014	Merritt et al.	2017/0014084	A1	1/2017	Al-Ali et al.
2014/0336481	A1	11/2014	Shakespeare et al.	2017/0027456	A1	2/2017	Kinast et al.
2014/0357966	A1	12/2014	Al-Ali et al.	2017/0042488	A1	2/2017	Muhsin
2015/0005600	A1	1/2015	Blank et al.	2017/0055847	A1	3/2017	Kiani et al.
2015/0011907	A1	1/2015	Purdon et al.	2017/0055851	A1	3/2017	Al-Ali
2015/0012231	A1	1/2015	Poeze et al.	2017/0055882	A1	3/2017	Al-Ali et al.
2015/0032029	A1	1/2015	Al-Ali et al.	2017/0055887	A1	3/2017	Al-Ali
2015/0038859	A1	2/2015	Dalvi et al.	2017/0055896	A1	3/2017	Al-Ali et al.
2015/0045637	A1	2/2015	Dalvi	2017/0079594	A1	3/2017	Telfort et al.
2015/0080754	A1	3/2015	Purdon et al.	2017/0086723	A1	3/2017	Al-Ali et al.
2015/0087936	A1	3/2015	Al-Ali et al.	2017/0143281	A1	5/2017	Olsen
2015/0094546	A1	4/2015	Al-Ali	2017/0147774	A1	5/2017	Kiani
2015/0097701	A1	4/2015	Al-Ali et al.	2017/0156620	A1	6/2017	Al-Ali et al.
2015/0099950	A1	4/2015	Al-Ali et al.	2017/0173632	A1	6/2017	Al-Ali
2015/0099951	A1	4/2015	Al-Ali et al.	2017/0187146	A1	6/2017	Kiani et al.
2015/0099955	A1	4/2015	Al-Ali et al.	2017/0188919	A1	7/2017	Al-Ali et al.
2015/0101844	A1	4/2015	Al-Ali et al.	2017/0196464	A1	7/2017	Jansen et al.
2015/0106121	A1	4/2015	Muhsin et al.	2017/0196470	A1	7/2017	Lamego et al.
2015/0112151	A1	4/2015	Muhsin et al.	2017/0202490	A1	7/2017	Al-Ali et al.
2015/0116076	A1	4/2015	Al-Ali et al.	2017/0224231	A1	8/2017	Al-Ali
2015/0126830	A1	5/2015	Schurman et al.	2017/0224262	A1	8/2017	Al-Ali
2015/0141781	A1	5/2015	Weber et al.	2017/0228516	A1	8/2017	Sampath et al.
				2017/0245790	A1	8/2017	Al-Ali et al.
				2017/0251974	A1	9/2017	Shreim et al.
				2017/0251975	A1	9/2017	Shreim et al.
				2017/0258403	A1	9/2017	Abdul-Hafiz et al.

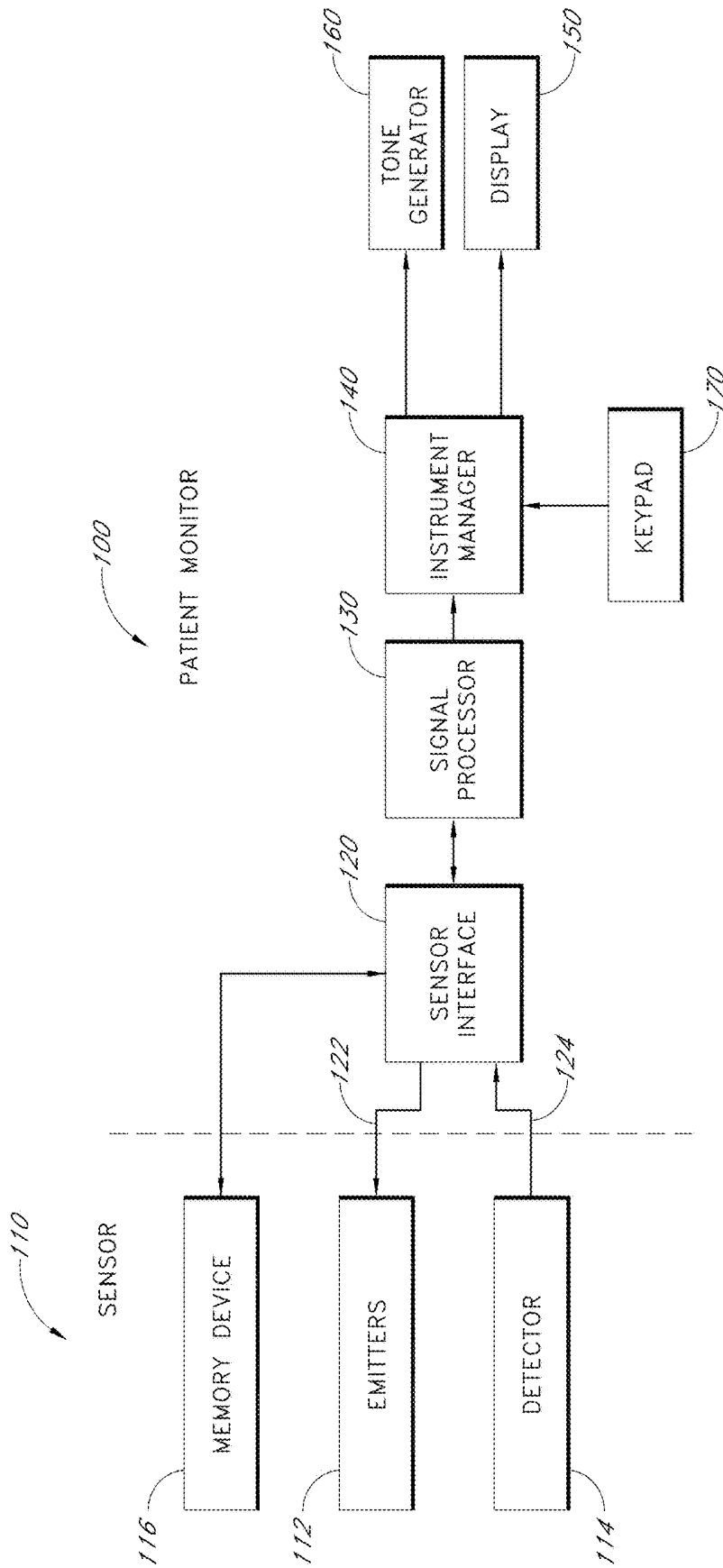
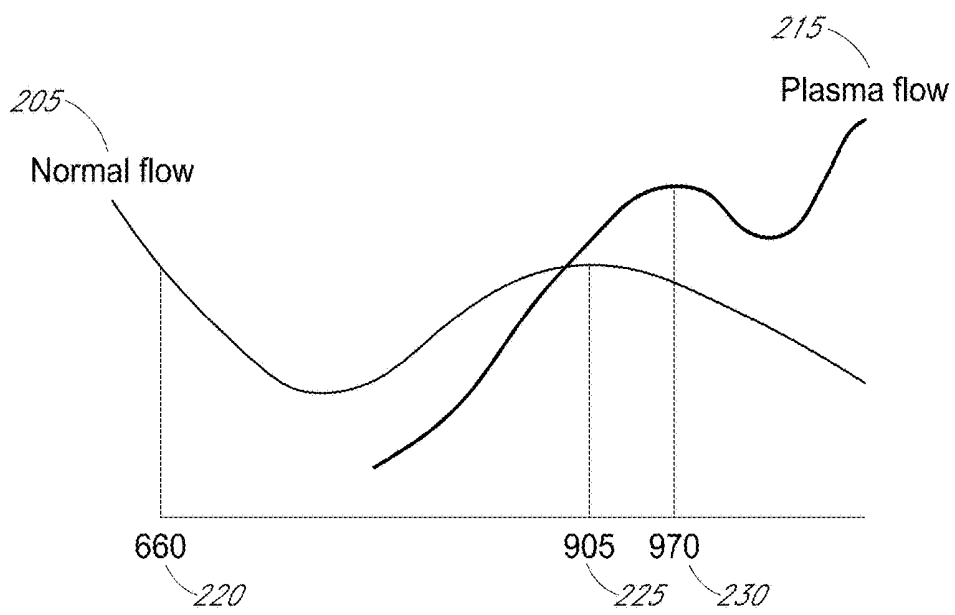

FIG. 1



*FIG. 2*

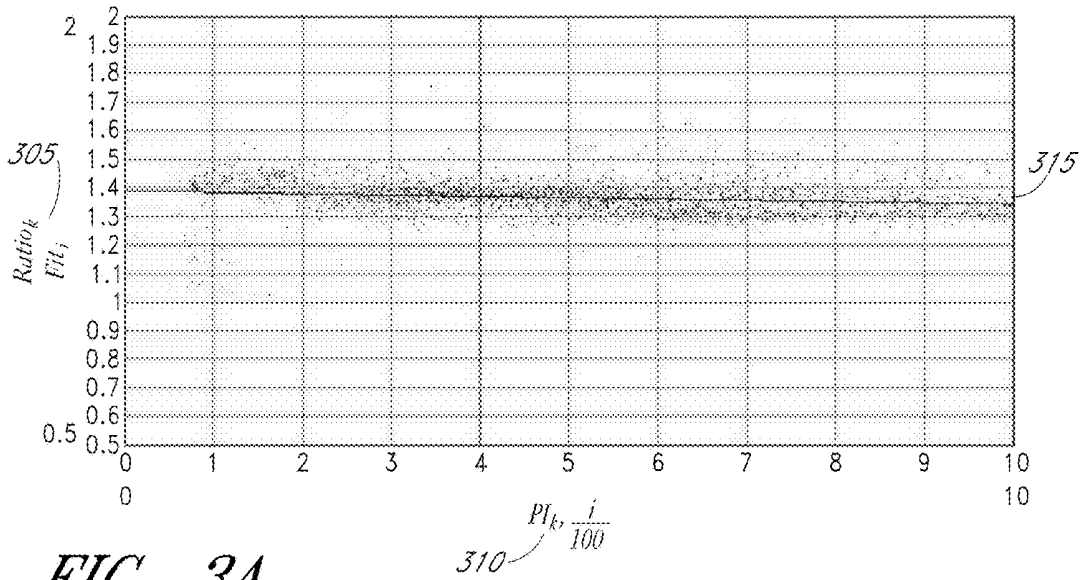

FIG. 3A

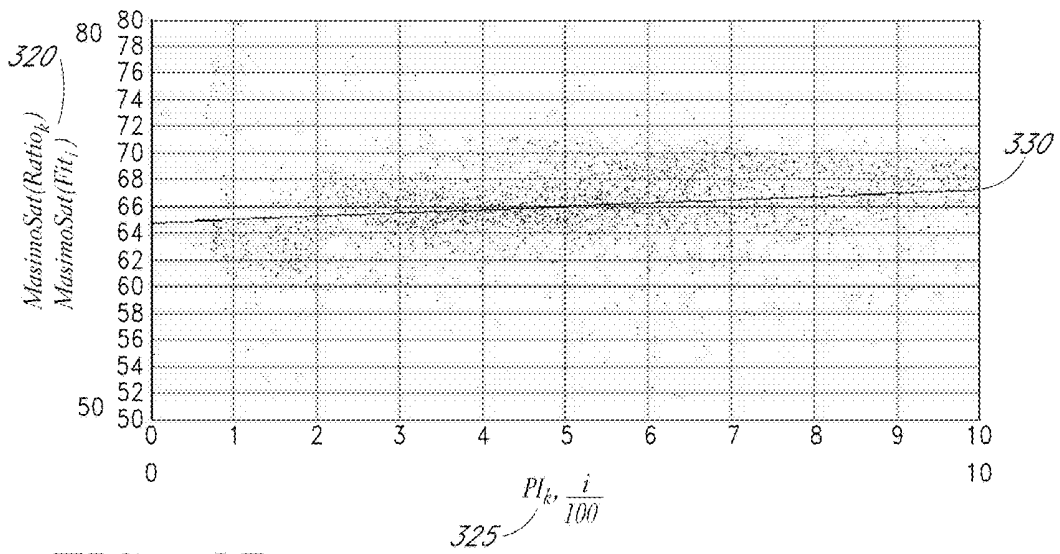

FIG. 3B

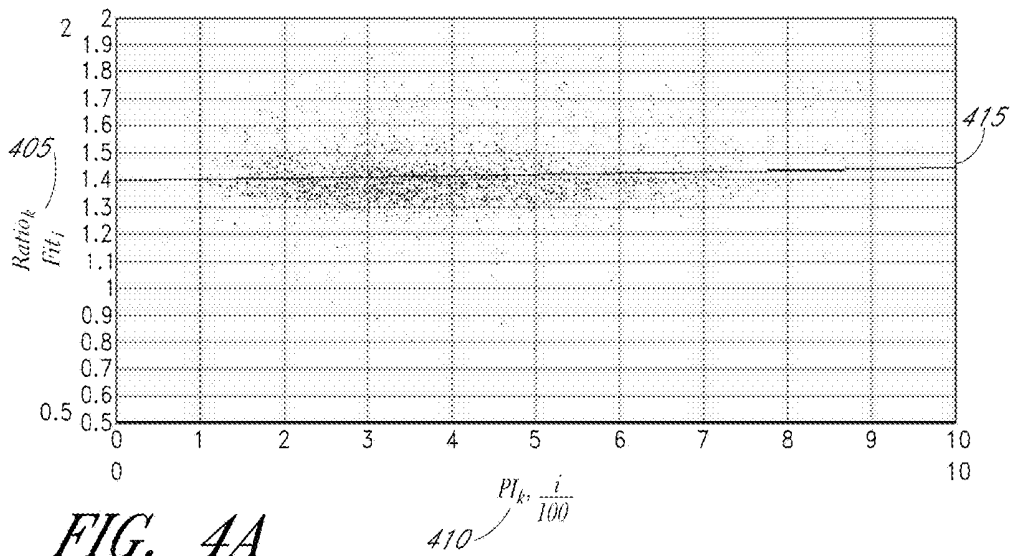

FIG. 4A

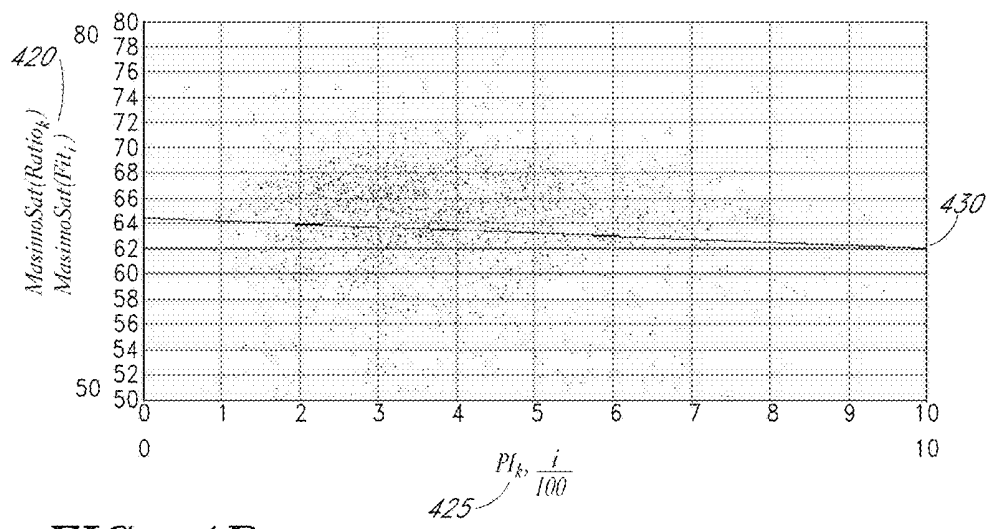

FIG. 4B

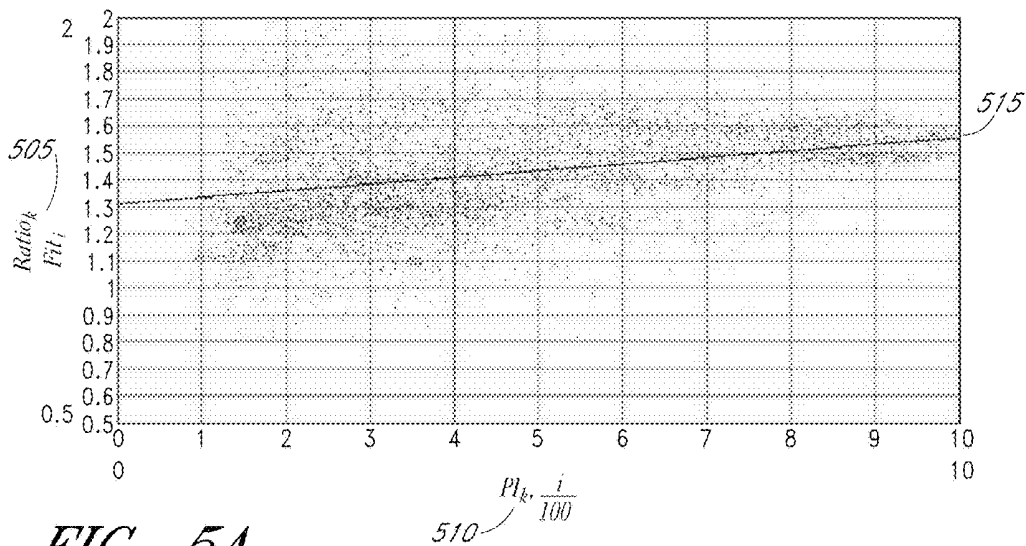

FIG. 5A

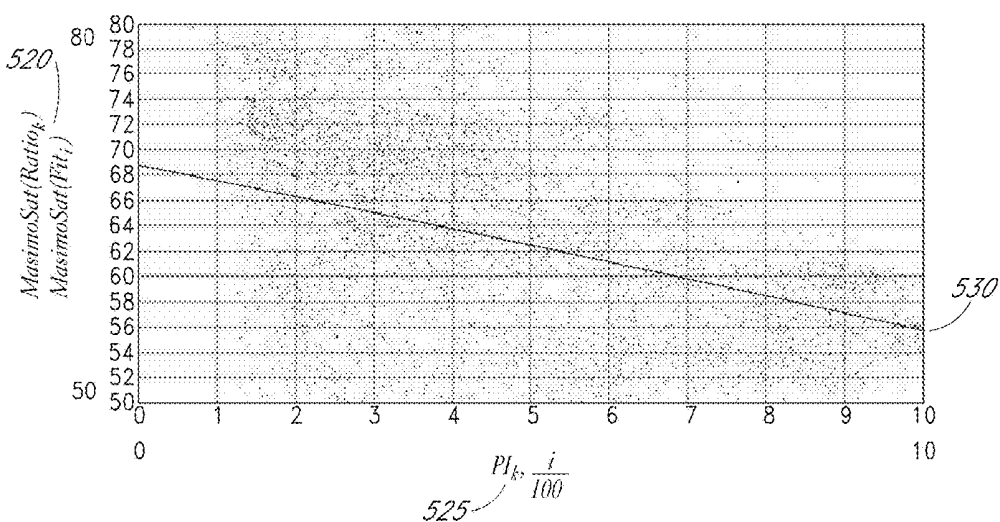

FIG. 5B

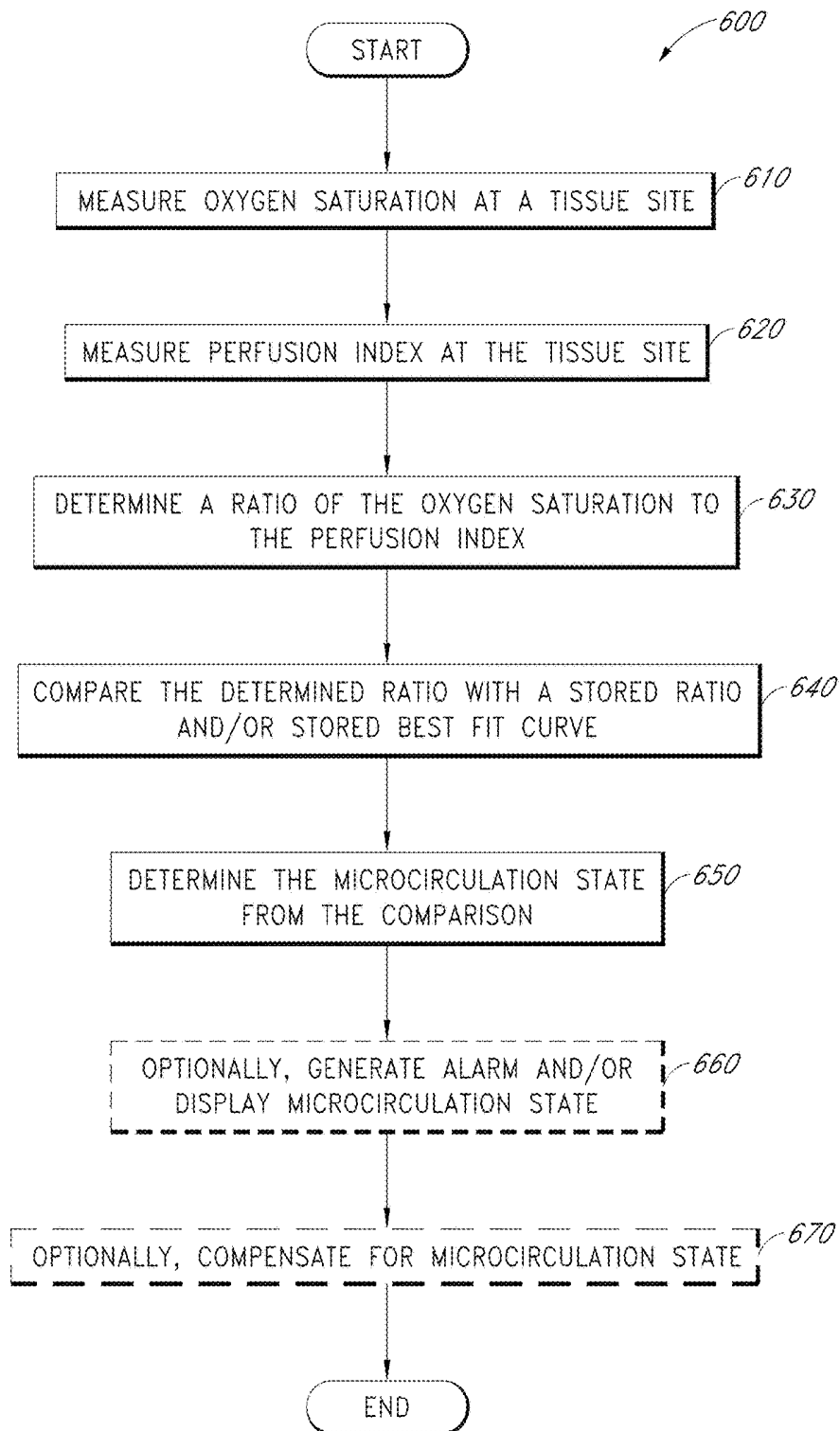

FIG. 6

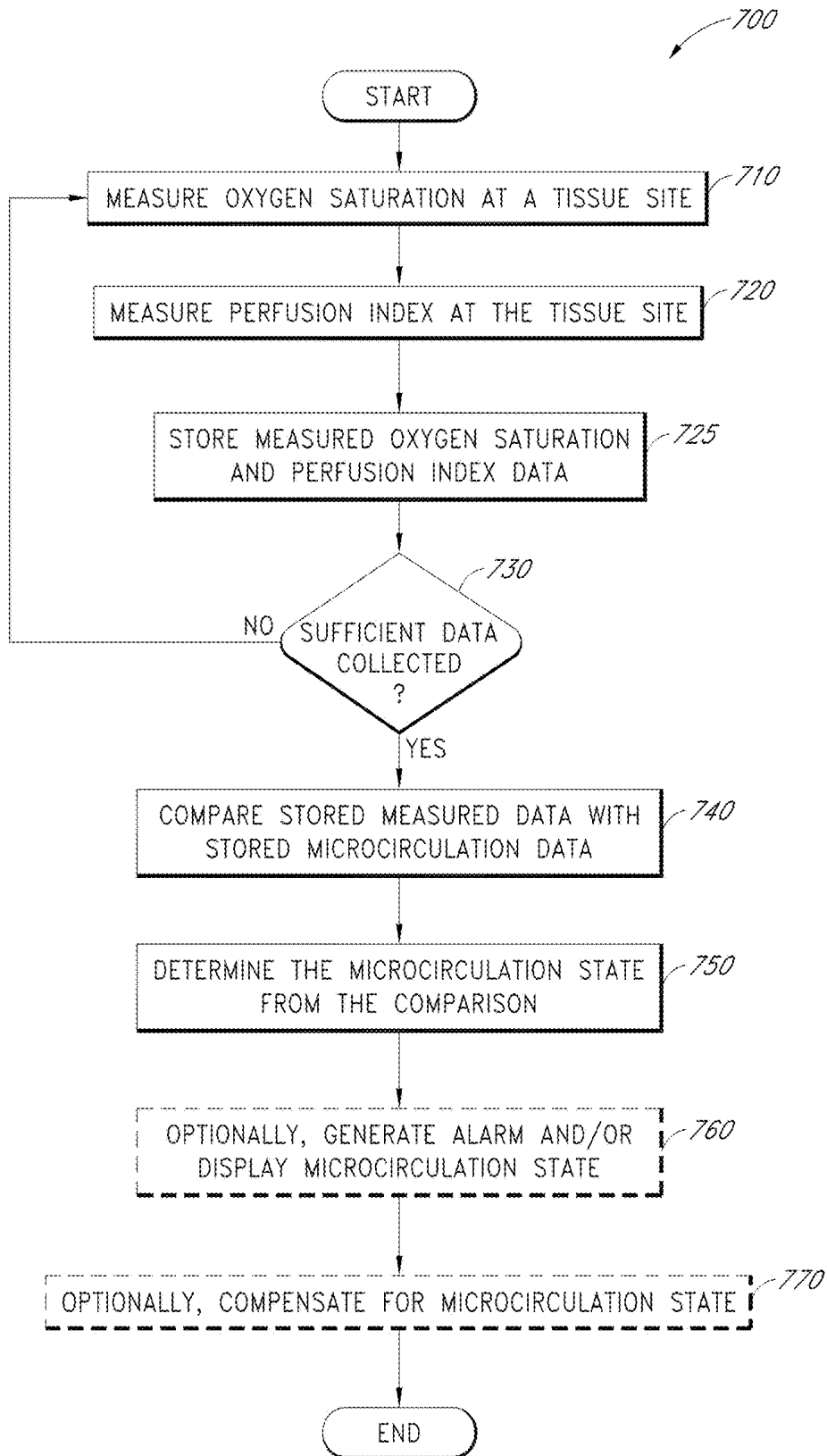

FIG. 7

## PATIENT MONITOR FOR DETERMINING MICROCIRCULATION STATE

### CROSS-REFERENCE TO RELATED APPLICATIONS

This application is a continuation of U.S. patent application Ser. No. 14/923,235, filed Oct. 26, 2015, titled PATIENT MONITOR FOR DETERMINING MICROCIRCULATION STATE, which is a continuation of U.S. patent application Ser. No. 14/160,316, filed Jan. 21, 2014, titled PATIENT MONITOR FOR DETERMINING MICROCIRCULATION STATE, which is a continuation of U.S. patent application Ser. No. 13/101,093, filed May 4, 2011, titled PATIENT MONITOR FOR DETERMINING MICROCIRCULATION STATE, which claims the benefit of priority under 35 U.S.C. § 119(e) of U.S. Provisional Application No. 61/332,155, filed May 6, 2010, titled PATIENT MONITOR FOR DETERMINING MICROCIRCULATION STATE, the entire contents of each of which are hereby incorporated by reference herein in their entireties.

### FIELD OF THE DISCLOSURE

The present disclosure relates to medical sensors and specifically to a medical sensor and/or monitor for determining the circulation state in blood vessels.

### BACKGROUND OF THE DISCLOSURE

Patient monitoring of various physiological parameters of a patient is important to a wide range of medical applications. Oximetry is one of the techniques that has developed to accomplish the monitoring of some of these physiological characteristics. It was developed to study and to measure, among other things, the oxygen status of blood. Pulse oximetry—a noninvasive, widely accepted form of oximetry—relies on a sensor attached externally to a patient to output signals indicative of various physiological parameters, such as a patient's constituents and/or analytes, including for example a percent value for arterial oxygen saturation, carbon monoxide saturation, methemoglobin saturation, fractional saturations, total hematocrit, bilirubins, perfusion quality, or the like. A pulse oximetry system generally includes a patient monitor, a communications medium such as a cable, and/or a physiological sensor having light emitters and a detector, such as one or more LEDs and a photodetector. The sensor is attached to a tissue site, such as a finger, toe, ear lobe, nose, hand, foot, or other site having pulsatile blood flow which can be penetrated by light from the emitters. The detector is responsive to the emitted light after attenuation by pulsatile blood flowing in the tissue site. The detector outputs a detector signal to the monitor over the communication medium, which processes the signal to provide a numerical readout of physiological parameters such as oxygen saturation (SpO<sub>2</sub>) and/or pulse rate.

High fidelity pulse oximeters capable of reading through motion induced noise are disclosed in U.S. Pat. Nos. 7,096,054, 6,813,511, 6,792,300, 6,770,028, 6,658,276, 6,157,850, 6,002,952, 5,769,785, and 5,758,644, which are assigned to Masimo Corporation of Irvine, Calif. ("Masimo Corp.") and are incorporated by reference herein. Advanced physiological monitoring systems can incorporate pulse oximetry in addition to advanced features for the calculation and display of other blood parameters, such as carboxyhemoglobin (HbCO), methemoglobin (HbMet), total hemoglobin (Hbt),

total Hematocrit (Hct), oxygen concentrations, glucose concentrations, blood pressure, electrocardiogram data, temperature, and/or respiratory rate as a few examples. Typically, the physiological monitoring system provides a numerical readout of and/or waveform of the measured parameter. Advanced physiological monitors and multiple wavelength optical sensors capable of measuring parameters in addition to SpO<sub>2</sub>, such as HbCO, HbMet and/or Hbt are described in at least U.S. patent application Ser. No. 11/367,013, filed Mar. 1, 2006, titled Multiple Wavelength Sensor Emitters and U.S. patent application Ser. No. 11/366,208, filed Mar. 1, 2006, titled Noninvasive Multi-Parameter Patient Monitor, assigned to Masimo Laboratories, Inc. and incorporated by reference herein. Further, noninvasive blood parameter monitors and optical sensors including Rainbow™ adhesive and reusable sensors and RAD-57™ and Radical-7™ monitors capable of measuring SpO<sub>2</sub>, pulse rate, perfusion index (PI), signal quality (SiQ), pulse variability index (PVI), HbCO and/or HbMet, among other parameters, are also commercially available from Masimo Corp.

During blood circulation, arteries carry blood away from the heart in high volume and under high pressure. Arteries branch off into smaller blood vessels, called arterioles. Arterioles are well innervated, surrounded by smooth muscle cells, and are about 10-100 μm in diameter. Arterioles carry the blood to the capillaries, which are the smallest blood vessels, which are not innervated, have no smooth muscle, and are about 5-8 μm in diameter. Blood flows out of the capillaries into the venules, which have little smooth muscle and are about 10-200 μm in diameter. The blood flows from venules into the veins, which carry blood back to the heart.

Microcirculation generally refers to the vascular network lying between the arterioles and the venules, including the capillaries, as well as the flow of blood through this network. These small vessels can be found in the vasculature which are embedded within organs and are responsible for the distribution of blood within tissues as opposed to larger vessels in the macrocirculation which transport blood to and from the organs. One of the functions of microcirculation is to deliver oxygen and other nutrients to tissue. Sometimes, microcirculation in these small vessels can become blocked, interfering with the delivery of oxygen to the tissue.

### SUMMARY OF THE DISCLOSURE

As placement of a physiological monitoring sensor is typically at a sensor site located at an extremity of the body, the state of microcirculation, such as whether vessels are blocked or open, can have a significant effect on the readings at the sensor site. It is therefore desirable to provide a patient monitor and/or physiological monitoring sensor capable of distinguishing the microcirculation state of blood vessels. In some embodiments, the patient monitor and/or sensor provide a warning and/or compensates a measurement based on the microcirculation state. In some embodiments, a microcirculation determination process implementable by the patient monitor and/or sensor is used to determine the state of microcirculation of the patient.

### BRIEF DESCRIPTION OF THE DRAWINGS

Throughout the drawings, reference numbers may be re-used to indicate correspondence between referenced ele-

ments. The drawings are provided to illustrate embodiments of the disclosure described herein and not to limit the scope thereof.

FIG. 1 illustrates a block diagram of a patient monitor, such as a pulse oximeter, and associated sensor;

FIG. 2 illustrates an example graph depicting the optical absorption characteristic of normal blood and plasma;

FIGS. 3A and 3B illustrate graphs of oxygen saturation values for a normal microcirculation state data set;

FIGS. 4A and 4B illustrate graphs of oxygen saturation values for another normal microcirculation state data set;

FIGS. 5A and 5B illustrate graphs of oxygen saturation values for an anomalous microcirculation state data set;

FIG. 6 illustrates a flow diagram for a process for determining the state of microcirculation usable by a pulse oximeter; and

FIG. 7 illustrates a flow diagram for a process for determining the state of microcirculation wherein multiple data points are collected.

### DETAILED DESCRIPTION

FIG. 1 illustrates a block diagram of a patient monitor 100, such as a pulse oximeter, and associated sensor 110. Generally, in the case of a pulse oximeter, the sensor 110 has LED emitters 112, generally one at a red wavelength and one at an infrared wavelength, and a photodiode detector 114. The sensor 110 is generally attached to an adult patient's finger or an infant patient's foot. For a finger, the sensor 110 is configured so that the emitters 112 project light through the fingernail and through the blood vessels and capillaries underneath. The LED emitters 112 are activated by drive signals 122 from the pulse oximeter 100. The detector 114 is positioned at the fingertip opposite the fingernail so as to detect the LED emitted light as it emerges from the finger tissues. The photodiode generated signal 124 is relayed by a cable to the pulse oximeter 100.

A pulse oximeter 100 determines oxygen saturation (SpO<sub>2</sub>) by computing the differential absorption by arterial blood of the two wavelengths emitted by the sensor 110. A typical pulse oximeter 100 contains a sensor interface 120, one or more processors 130, such as a SpO<sub>2</sub> processor, an instrument manager 140, a display 150, an audible indicator (tone generator) 160, and a keypad 170. The sensor interface 120 provides LED drive current 122 which alternately activates the sensor's red and infrared LED emitters 112. The sensor interface 120 also has input circuitry for amplification and filtering of the signal 124 generated by the photodiode detector 114, which corresponds to the red and infrared light energy attenuated from transmission through the patient tissue site. The SpO<sub>2</sub> processor 130 calculates a ratio of detected red and infrared intensities, and an arterial oxygen saturation value is empirically determined based on that ratio. The instrument manager 140 provides hardware and software interfaces for managing the display 150, audible indicator 160, and keypad 170. The display 150 shows the computed oxygen saturation status, as described above. Similarly, other patient parameters including HbCO, HbMet, Hbt, Hct, oxygen concentrations, glucose concentrations, pulse rate, PI, SiQ, and/or PVI can be computed. The audible indicator 160 provides the pulse beep as well as alarms indicating desaturation events. The keypad 170 provides a user interface for such things as alarm thresholds, alarm enablement, and/or display options.

Computation of SpO<sub>2</sub> relies on the differential light absorption of oxygenated hemoglobin, HbO<sub>2</sub>, and deoxygenated hemoglobin, Hb, to determine their respective con-

centrations in the arterial blood. Specifically, pulse oximetry measurements are made at red (R) and infrared (IR) wavelengths chosen such that deoxygenated hemoglobin absorbs more red light than oxygenated hemoglobin, and, conversely, oxygenated hemoglobin absorbs more infrared light than deoxygenated hemoglobin, for example 660 nm (R) and 905 nm (IR).

To distinguish between tissue absorption at the two wavelengths, the red and infrared emitters 112 are provided drive current 122 so that only one is emitting light at a given time. For example, the emitters 112 can be cycled on and off alternately, in sequence, with each only active for a quarter cycle and with a quarter cycle separating the active times. This allows for separation of red and infrared signals and removal of ambient light levels by downstream signal processing. Because only a single detector 114 is used, it responds to both the red and infrared emitted light and generates a time-division-multiplexed ("modulated") output signal 124. This modulated signal 124 is coupled to the input of the sensor interface 120.

In addition to the differential absorption of hemoglobin derivatives, pulse oximetry relies on the pulsatile nature of arterial blood to differentiate hemoglobin absorption from absorption of other constituents in the surrounding tissues. Light absorption between systole and diastole varies due to the blood volume change from the inflow and outflow of arterial blood at a peripheral tissue site. This tissue site might also comprise skin, muscle, bone, venous blood, fat, pigment, and/or the like, each of which absorbs light. It is assumed that the background absorption due to these surrounding tissues is invariant and can be ignored. Thus, blood oxygen saturation measurements are based upon a ratio of the time-varying or AC portion of the detected red and infrared signals with respect to the time-invariant or DC portion:  $R/IR = (Red_{AC}/Red_{DC}) / (IR_{AC}/IR_{DC})$ .

The desired SpO<sub>2</sub> measurement is then computed from this ratio. The relationship between R/IR and SpO<sub>2</sub> can be determined by statistical regression of experimental measurements obtained from human volunteers and calibrated measurements of oxygen saturation. In a pulse oximeter device, this empirical relationship can be stored as a "calibration curve" in a read-only memory (ROM) look-up table so that SpO<sub>2</sub> can be directly read-out of the memory in response to input R/IR measurements.

The pulse oximeter 100 can also measure perfusion index, PI, which is a numerical value that indicates the strength of the IR signal returned from a monitoring site and provides a relative assessment of the pulse strength at the monitoring site. The perfusion index can be defined as follows:  $PI = (IR_{max} - IR_{min}) / IR_{DC}$ , where  $IR_{max}$  is the maximum value,  $IR_{min}$  is the minimum value, and  $IR_{DC}$  is the average value of the invariant portion. As the light absorption characteristic of blood is typically "flatter" or less sensitive to oxygen saturation around the infrared wavelength, the infrared signal from a sensor is influenced primarily by the amount of the blood at the monitoring site, not by the level of oxygenation in the blood. Accordingly, the perfusion index, which is a numerical value that indicates the strength of the IR signal returned from a monitoring site, provides a relative assessment of the pulse strength at the monitoring site. PI values generally range from 0.02% (very weak pulse strength) to 20% (very strong pulse strength). In some embodiments, PI can be measured using other wavelengths. For example, red, near red, near IR, as well as other wavelengths can be used.

In an embodiment, the sensor 110 also includes a memory device 116. The memory 116 can include any one or more

of a wide variety of memory devices known to an artisan from the disclosure herein, including erasable programmable read only memory (EPROM), electrically erasable programmable read-only memory (EEPROM), flash memory, other non-volatile memory, a combination of the same or the like. The memory 116 can include read-only memory such as read-only memory (ROM), a read and write device such as a random-access memory (RAM), combinations of the same, or the like. The remainder of the present disclosure will refer to such combination as simply EPROM for ease of disclosure; however, an artisan will recognize from the disclosure herein that the memory can include ROM, RAM, single wire memory, other types of memory, combinations of the same, or the like.

The memory device 116 can advantageously store some or all of a wide variety of data and information, including, for example, information on the type or operation of the sensor, type of patient or body tissue, buyer or manufacturer information, sensor characteristics including the number of wavelengths capable of being emitted, emitter specifications, emitter drive requirements, demodulation data, calculation mode data, calibration data, software such as scripts, executable code, or the like, sensor electronic elements, sensor life data indicating whether some or all sensor components have expired and should be replaced, encryption information, monitor or algorithm upgrade instructions or data, or the like. In an embodiment, the memory device can also include oxygen saturation to perfusion index and R/IR ratio to perfusion index ratios and/or data.

In certain situations, pulse oximetry sensors may produce anomalous readings, such as when a patient suffers from cyanosis. In a patient suffering from cyanosis, blood cells are uncharacteristically low on oxygen, leading to oxygen deficiency and giving the patient's skin a bluish-hue. One potential cause is that the patient's body produces too much hemoglobin, making the blood "thicker" or slower flowing, making microcirculation vessels more prone to blockage. Thus, a "blocked" microcirculation state can indicate cyanosis.

A "blocked" microcirculation state can also indicate other medical conditions, such as sepsis, systemic inflammatory response syndrome (SIRS), or septicemia. Sepsis is a potentially deadly medical condition that is characterized by a whole-body inflammatory state (called SIRS) and the presence of a known or suspected infection. The body may develop this inflammatory response by the immune system to microbes in the blood, urine, lungs, skin, or other tissue. Septicemia is a related medical term referring to the presence of pathogenic organisms in the bloodstream, which can lead to sepsis. Sepsis can also be referred to as blood poisoning. During sepsis or SIRS, inflammation in the body can cause constriction in blood vessels, leading to low blood pressure or insufficient blood flow.

During a "blocked" microcirculation state, blood cells can get blocked in the microcirculation vessels, such as the arterioles and capillaries. Blood cells can clump together or otherwise catch against the wall of blood vessels, creating a blockage that prevents blood cells, including red blood cells carrying hemoglobin, from passing through the blockage. However, plasma, which is composed of mostly water and in which the blood cells are suspended, is generally able to flow through passages in the blockage. In some situations, some blood vessels at the monitoring site may continue to have normal flow while some vessels are blocked. Thus, a "blocked" microcirculation state can indicate that some microcirculation vessels in an area are blocked and not necessarily all vessels in the area are blocked.

With the blockage preventing most or all the red blood cells from passing a blood vessel, at most only a limited amount of hemoglobin passes through a blocked blood vessel. In some situations, the blood vessel may only be partially blocked, where some hemoglobin passes through but less than when the blood vessel is unblocked. Normally, blood is made up of about 40-50% of red blood cells, of which about 95% is hemoglobin. Plasma, which is about 95% water, normally constitutes about 55% of the blood's volume.

Accordingly, a pulse oximeter placed on a tissue site experiencing blockage in microcirculation vessels may detect mostly plasma passing through with no or only a small percentage of red blood cells, at least at part of the monitoring site. The resulting change in the normal composition of blood can cause anomalous readings in the pulse oximetry monitor. As plasma has generally different absorption characteristics for red and infrared wavelengths than normal blood, pulse oximetry readings may become skewed. Red<sub>AC</sub> and/or IR<sub>AC</sub> can be affected, causing measured R/IR ratio to change. For example, if Red<sub>AC</sub> rises or IR<sub>AC</sub> drops, the R/IR ratio increases. Alternatively, if Red<sub>AC</sub> drops or IR<sub>AC</sub> rises, the R/IR ratio decreases. Thus, the value of R/IR can change due to a change in the light absorption of blood even if the underlying oxygen saturation of the blood remains the same.

However, by comparing oxygen saturation and PI for normal microcirculation to the oxygen saturation and PI for blocked microcirculation, such as by calculating and comparing ratios, the monitor can determine the existence of an abnormal situation. Typically, SpO<sub>2</sub> is mostly independent of PI, with SpO<sub>2</sub> varying minimally as PI increases. However, SpO<sub>2</sub> varying by more than normal as PI increases can indicate an anomalous microcirculation state, such as a blockage. In one embodiment, by analyzing the measured ratios, the pulse oximeter 100 can determine the microcirculation state, such as whether a blocked vessel exists in the microcirculation vessels.

FIG. 2 illustrates an example graph depicting the optical absorption characteristic of normal blood and plasma. The graph depicts sampling wavelengths at 660 nm 220 and at 905 nm 225. As illustrated, IR absorption for plasma at a frequency of 905 nm is on a "steeper" section of the curve compared to the "flatter" section of the curve for normal blood. This can imply that readings for IR for plasma would be more sensitive to changes in the absorption quality of the blood. In contrast, the IR measurement for normal blood, for example at 905 nm, is usually insensitive to a change in oxygenation of normal blood, but more affected by change in the amount of blood. As illustrated in the graph, plasma can have a "flatter" section in its absorption curve at a different wavelength, for example at 970 nm 230.

FIGS. 3A and 3B illustrate graphs of oxygen saturation values for a normal microcirculation state data set. FIG. 3A has a y-axis 305 corresponding to the measured ratio, R/IR, and a x-axis 310 corresponding to perfusion index, PI. FIG. 3B has a y-axis 320 corresponding to measured oxygen saturation, and an x-axis 325 corresponding to perfusion index, PI. FIGS. 3A and 3B represent multiple data points with a best fit line 315, 330 indicating the trend of the data points. Each data point represents a measurement. As illustrated, the best fit line for FIG. 3A trends slightly downward and the best fit line for FIG. 3B trends slightly upwards. However, there is generally only a small change in the y-axis for the best fit line as PI increases, with the change in FIG. 3A around 0.1 and the change in FIG. 3B around 4.

FIGS. 4A and 4B illustrate graphs of oxygen saturation values for another normal microcirculation state data set. FIG. 4A has a y-axis 405 corresponding to the measured ratio, R/IR, and an x-axis 410 corresponding to perfusion index, PI. FIG. 4B has a y-axis 420 corresponding to measured oxygen saturation, and an x-axis 425 corresponding to perfusion index, PI. FIGS. 4A and 4B represent multiple data points with a best fit line 415, 430 indicating the trend of the data points. Each data point represents a measurement. As illustrated, the best fit line for FIG. 4A trends slightly upwards and the best fit line for FIG. 4B trends slightly downwards. However, there is generally only a small change in the y-axis for the best fit line as PI increases, with the change in FIG. 4A around 0.1 and the change in FIG. 4B around 3.

FIGS. 5A and 5B illustrate graphs of oxygen saturation values for an anomalous microcirculation state data set. FIG. 5A has a y-axis 505 corresponding to the measured ratio, R/IR, and an x-axis 510 corresponding to perfusion index, PI. FIG. 5B has a y-axis 520 corresponding to measured oxygen saturation, and an x-axis 525 corresponding to perfusion index, PI. FIGS. 5A and 5B represent multiple data points with a best fit line 515, 530 indicating the trend of the data points. Each data point represents a measurement. As illustrated, the best fit line for FIG. 5A trends significantly upwards on the y-axis by around 0.3 and the best fit line for FIG. 5B trends significantly downwards on the y-axis by around 13 as PI increases.

In comparison to FIGS. 3A and 4A, FIG. 5A shows a high R/IR ratio for low values of PI that becomes a high R/IR ratio as PI increases. In comparison to FIGS. 3B and 4B, FIG. 5B shows a high reading for low values of PI that becomes a low reading as PI increases. Differences between the graphs can be explained by the microcirculation state in FIGS. 5A and 5B being different from the microcirculation state in FIGS. 3A-4B. For example, FIGS. 5A and 5B can represent a "blocked" or partially blocked microcirculation state where the blood passing through the sensor includes mostly plasma. As discussed above, this can skew R/IR and the measured oxygen saturation derived from R/IR.

FIG. 6 illustrates a flow diagram for a process 600 for determining the state of microcirculation usable by a pulse oximeter. Microcirculation state can be determined by comparison with microcirculation data stored on a patient monitor, such as the pulse oximeter 100 of FIG. 1. The process 600 can be implemented by embodiments of the sensor 110 and/or patient monitor 100 of FIG. 1 or other suitable device.

While in conventional pulse oximetry, measurements are generally taken pulse-by-pulse and averaged over pulses, microcirculation measurements can be measured using only a single pulse or a portion of a single pulse. This can be done, for example, at the minimum and/or maximum blood flow of a pulse. Microcirculation measurements can also be determined over multiple pulses. In some embodiments, microcirculation measurements are taken during a portion of the normal measurement time used by a physiological sensor to take a measurement of a parameter, thereby allowing detection of aberrant parameter measurements using the microcirculation measurements. For example, while a pulse oximeter is measuring SpO2 over several pulses, microcirculation measurements can be taken per pulse and a warning given if an irregular microcirculation state is detected, thereby notifying a user of a possible aberration in the current SpO2 reading.

At block 610, oxygen saturation is measured at a tissue monitoring site. In one embodiment, oxygen saturation is determined using a pulse oximeter sensor.

At block 620, perfusion index or pulse strength is measured. In one embodiment, the perfusion index is determined using the same sensor used to measure oxygen saturation so that readings are taken at the same monitoring site.

At block 630, a ratio of oxygen saturation to perfusion index is determined. Oxygen saturation can be a SpO2 value based on the measured R/IR ratio looked-up against a calibration curve. Alternatively, the ratio can be perfusion index to oxygen saturation. In other embodiments, the measured R/IR ratio can be used directly instead of SpO2.

In some embodiments, multiple readings of perfusion index and oxygen saturation can be taken and averaged together before determining the ratio in order to account for outliers. The multiple readings can be filtered before averaging. For example, readings can first be filtered based on closeness of PI values before the readings are averaged together.

At block 640, the determined ratio in block 630 is compared to stored microcirculation data. The stored data can be data sets for microcirculation states. In some embodiments, a ratio, a curve, a line, table, data points, or formula can be stored that corresponds to a data set. The measured perfusion index and oxygen saturation can then be compared to the stored data. In some embodiments, multiple readings are taken and a best fit line or curve is generated and compared to a stored best fit line or curve. In some embodiments, readings are collected at various PI values in order to generate a trend line.

At block 650, the microcirculation state is determined from comparison of the stored microcirculation data. For example, if the determined ratio is similar to a stored ratio corresponding to a data set for unblocked microcirculation, the microcirculation state is determined to be unblocked. Other data sets for other microcirculation states, such as blocked and/or partially blocked can also be stored. Where multiple data sets are stored, the state can be determined by selecting the state corresponding to the stored ratio closest to the measured ratio.

At block 660, the monitor can optionally generate an alarm and/or display the microcirculation state. For example, an alarm signal can be generated by the monitor to indicate that the readings may be anomalous, such as when a blocked or partially blocked microcirculation state is detected. The alarm can be a visual indicator (e.g., icon, message or image) and/or an audio indicator. In an embodiment, the alarm can indicate the detection of cyanosis, sepsis, SIRS or other medical condition based at least partly on the determined microcirculation state. In some situations, no action is taken, such as when readings are determined to be normal or non-threatening.

At block 670, the monitor can optionally compensate for the microcirculation state in order to improve accuracy of the readings. After the microcirculation state returns to normal, the compensation process can be ended.

In one embodiment, an offset can be added to the measured parameter value, such as SpO2. The offset can be calculated based on data sets for microcirculation state. Different microcirculation states can have different offsets. For example, if a "blocked" microcirculation state produces high readings for low PI values, a negative offset can be used. However, if a "blocked" state produces a low value for high PI values, then a positive offset can be used. In one embodiment, a varying offset can be used depending on the value of PI.

In one embodiment, a different wavelength emitter can be used to compensate for a microcirculation state. For example, rather than using a regular infrared emitter, typi-

cally 905 nm, an emitter with a different infrared wavelength, such as 970 nm can be used. In one embodiment, the different wavelength is selected such that the wavelength is at a “flat” section of the light absorption curve for plasma, that is, where the light absorption is not much affected by changes in oxygen saturation. In one embodiment, the selected wavelength with regards to plasma mimics the properties of the regular wavelength with regards to normal flowing blood. In some embodiments, a different wavelength red emitter can be used instead of the regular red wavelength emitter.

In some embodiments, the pulse oximeter sensor used to measure oxygen saturation and PI can be provided with an additional emitter at a different wavelength than the existing emitters. When a certain microcirculation state is detected, such as a “blocked” state, the additional emitter can be used. For example, a pulse oximetry sensor can be equipped with LED’s capable of emitting at 660 nm, 905 nm, and at 970 nm wavelengths. Under normal operation, the 660 nm and 905 nm emitters are active. However, upon detecting a blocked microcirculation state, the 905 nm emitter can be deactivated and the 970 nm emitter activated in its place. In some embodiments, a variable wavelength emitter can be used rather than separate emitters. In some embodiments, the additional emitter can be a red wavelength emitter.

FIG. 7 illustrates a flow diagram for a process 700 for determining the state of microcirculation wherein multiple data points are collected. The process 700 can be implemented by embodiments of the sensor 110 and/or patient monitor 100 of FIG. 1 or other suitable device.

At block 710 and block 720, oxygen saturation and perfusion index are measured. At block 725, measured values are stored in memory. Each paired measurement forms a data point.

At block 730, the number of stored data points is checked to determine if sufficient data has been collected to determine the microcirculation state. Data can be sufficient if a set number of data points have been collected, a set amount of time has passed, and/or a spectrum of data points have been collected, such as for differing values of PI.

At block 740, the stored measured data is compared with stored microcirculation data. Typically, the microcirculation data is pre-stored on the pulse oximeter before use, as opposed to collected during use. A comparison can involve generating a curve or line from the measured data, calculating a rate of change for the stored data, generating a trend line for the measured data or the like and comparing with the stored microcirculation data.

At block 750, the microcirculation state is determined from comparison of the stored microcirculation data. For example, if the measured data is similar to microcirculation data corresponding to a data set for unblocked microcirculation, the microcirculation state is determined to be unblocked. Other data sets for other microcirculation states, such as for blocked and/or partially blocked can also be stored. Where multiple data sets are stored, the state can be determined by selecting the state corresponding to the stored ratio closest to the measured ratio.

Blocks 760 and 770 are similar to steps 660 and 670 described in FIG. 6.

As will be apparent from the above description, the R/IR ratio corresponds to oxygen saturation or SpO2 and can be used in place of oxygen saturation or SpO2 for the above comparisons, and vice versa.

While the above systems and methods have been described in terms of oxygen saturation and PI, other physiological parameters can be measured in place of or in

addition to oxygen saturation and/or perfusion index and used to determine microcirculation state. For example, perfusion index is an indication of amplitude and/or signal strength and other parameters or measurements indicating amplitude and/or signal strength can be used. In some embodiments, one or more different sensors can be used in place of or in addition to a pulse oximeter sensor.

Conditional language used herein, such as, among others, “can,” “could,” “might,” “may,” “e.g.,” and the like, unless specifically stated otherwise, or otherwise understood within the context as used, is generally intended to convey that certain embodiments include, while other embodiments do not include, certain features, elements and/or states. Thus, such conditional language is not generally intended to imply that features, elements and/or states are in any way required for one or more embodiments or that one or more embodiments necessarily include logic for deciding, with or without author input or prompting, whether these features, elements and/or states are included or are to be performed in any particular embodiment. The terms “comprising,” “including,” “having,” and the like are synonymous and are used inclusively, in an open-ended fashion, and do not exclude additional elements, features, acts, operations, and so forth. Also, the term “or” is used in its inclusive sense (and not in its exclusive sense) so that when used, for example, to connect a list of elements, the term “or” means one, some, or all of the elements in the list.

Various systems and processes for determining microcirculation state have been disclosed in detail in connection with various embodiments. These embodiments are disclosed by way of examples only and are not to limit the scope of the claims that follow. Indeed, the novel methods and systems described herein can be embodied in a variety of other forms; furthermore, various omissions, substitutions and changes in the form of the methods and systems described herein can be made without departing from the spirit of the inventions disclosed herein. The claims and their equivalents are intended to cover such forms or modifications as would fall within the scope and spirit of certain of the inventions disclosed herein. One of ordinary skill in the art will appreciate the many variations, modifications and combinations. For example, the various embodiments of the microcirculation determination process can be used with other oxygen saturation sensors and with both disposable and reusable sensors. In some embodiments, the determination process can be applied to other blood vessels to detect a blockage, even in vessels not involved in microcirculation.

Furthermore, in certain embodiments, the systems and methods described herein can advantageously be implemented using computer software, hardware, firmware, or any combination of software, hardware, and firmware. In one embodiment, the system includes a number of software modules that comprise computer executable code for performing the functions described herein. In certain embodiments, the computer-executable code is executed on one or more general purpose computers or processors. However, a skilled artisan will appreciate, in light of this disclosure, that any module that can be implemented using software can also be implemented using a different combination of hardware, software or firmware. For example, such a module can be implemented completely in hardware using a combination of integrated circuits. Alternatively or additionally, such a module can be implemented completely or partially using specialized computers or processors designed to perform the particular functions described herein rather than by general purpose computers or processors.

Moreover, certain embodiments of the invention are described with reference to methods, apparatus (systems) and computer program products that can be implemented by computer program instructions. These computer program instructions can be provided to a processor of a general purpose computer, special purpose computer, or other programmable data processing apparatus to produce a machine, such that the instructions, which execute via the processor of the computer or other programmable data processing apparatus, create means for implementing the acts specified herein to transform data from a first state to a second state.

Each of the processes, methods, and algorithms described in the preceding sections may be embodied in, and fully or partially automated by, code modules executed by one or more computers or computer processors. The code modules may be stored on any type of non-transitory computer-readable medium or computer storage device, such as hard drives, solid state memory, optical disc, and/or the like. The processes and algorithms may be implemented partially or wholly in application-specific circuitry. The results of the disclosed processes and process steps may be stored, persistently or otherwise, in any type of non-transitory computer storage such as, e.g., volatile or non-volatile storage.

The various features and processes described above may be used independently of one another, or may be combined in various ways. All possible combinations and subcombinations are intended to fall within the scope of this disclosure. In addition, certain method or process blocks may be omitted in some implementations. The methods and processes described herein are also not limited to any particular sequence, and the blocks or states relating thereto can be performed in other sequences that are appropriate. For example, described blocks or states may be performed in an order other than that specifically disclosed, or multiple blocks or states may be combined in a single block or state. The example blocks or states may be performed in serial, in parallel, or in some other manner. Blocks or states may be added to or removed from the disclosed example embodiments. The example systems and components described herein may be configured differently than described. For example, elements may be added to, removed from, or rearranged compared to the disclosed example embodiments.

While certain example embodiments have been described, these embodiments have been presented by way of example only, and are not intended to limit the scope of the inventions disclosed herein. Thus, nothing in the foregoing description is intended to imply that any particular feature, characteristic, step, module, or block is necessary or indispensable. Indeed, the novel methods and systems described herein may be embodied in a variety of other forms; furthermore, various omissions, substitutions and changes in the form of the methods and systems described herein may be made without departing from the spirit of the inventions disclosed herein. The accompanying claims and their equivalents are intended to cover such forms or modifications as would fall within the scope and spirit of certain of the inventions disclosed herein.

What is claimed is:

1. A patient monitor configured to monitor a patient and determine a microcirculation condition of the patient, the patient monitor comprising:

a sensor interface configured to receive a signal from a physiological sensor that is configured to transmit light of at least a first wavelength and a second wavelength into tissue of a patient and to detect the light after it has

been attenuated by the tissue, wherein the signal is responsive to the detected light; and  
one or more processors configured to:

process the signal to determine at least:

a measure of oxygen saturation of the tissue of the patient, and

an other calculated parameter responsive to a physiological characteristic of the tissue of the patient;

determine a relationship between the measure of oxygen saturation and the other calculated parameter;

compare the determined relationship with at least some of a plurality of previously determined data sets, wherein the previously determined data sets indicate microcirculation conditions associated with different relationships between measures of oxygen saturation and other calculated parameters; and

responsive to determining, based on said comparing, that a microcirculation condition of the patient comprises an at least partially blocked microcirculation condition in at least a portion of blood vessels in the tissue of the patient, perform at least one of:

provide an electronic microcirculation condition indication for review by a caregiver,

cause the physiological sensor to be configured to transmit at least a portion of the light at a different wavelength, or

apply an offset of to at least one of the measure of oxygen saturation or the other calculated parameter to compensate for the at least partially blocked microcirculation condition.

2. The patient monitor of claim 1, wherein the one or more processors are further configured to:

determine that the microcirculation condition is indicative of cyanosis and/or sepsis; and

in response to determining that the microcirculation condition is indicative of cyanosis and/or sepsis, provide the electronic microcirculation indication.

3. The patient monitor of claim 1, wherein the other calculated parameter comprises a measure of perfusion or perfusion index of the tissue of the patient.

4. The patient monitor of claim 3, wherein determining the relationship comprises:

determining a ratio of the measure of oxygen saturation to the measure of perfusion or perfusion index.

5. The patient monitor of claim 4, wherein comparing the determined relationship with at least some of the plurality of previously determined data sets comprises:

comparing the ratio with at least some of the plurality of previously determined data sets.

6. The patient monitor of claim 4, wherein the plurality of previously determined data sets comprise a plurality of lookup curves, and wherein comparing the determined relationship with at least some of the plurality of previously determined data sets further comprises:

generating a trend line based on the ratio and one or more other ratios determined based on further measures of oxygen saturation and perfusion or perfusion index obtained a different times; and

comparing the trend line to at least one lookup curve of the plurality of lookup curves.

7. The patient monitor of claim 1, wherein comparing the determined relationship with at least some of the plurality of previously determined data sets comprises:

determining one of the plurality of previously determined data sets that is most similar to the determined relationship.

## 13

8. The patient monitor of claim 1, wherein the oxygen saturation is responsive to differential absorption of hemoglobin derivatives.

9. The patient monitor of claim 1, wherein the at least partially blocked microcirculation condition indicates an at least partial blockage of hemoglobin.

10. The patient monitor of claim 1 further comprising: a memory storing the plurality of previously determined data sets, wherein:

at least some of the previously determined data sets indicate relationships between measures of oxygen saturation and the other calculated parameter that correspond to an at least partially blocked microcirculation condition, and

at least some of the previously determined data sets indicate relationships between measures of oxygen saturation and the other calculated parameter that correspond to an unblocked microcirculation condition.

11. A method of monitoring a patient and non-invasively determining a microcirculation condition of the patient, the method comprising:

receiving, from a non-invasive physiological sensor at a tissue site of a patient, a signal responsive to light of at least at first wavelength and a second wavelength that is transmitted by non-invasive physiological sensor and detected by the non-invasive physiological sensor after attenuation by tissue of the patient;

processing the signal to determine at least:

a measure of oxygen saturation of the tissue of the patient, and

an other calculated parameter responsive to a physiological characteristic of the tissue of the patient;

determining a relationship between the measure of oxygen saturation and the other calculated parameter;

comparing the determined relationship with at least some of a plurality of previously determined and stored relationships between measures of oxygen saturation and other calculated parameters, wherein:

at least some of the previously determined relationships correspond to an at least partially blocked microcirculation condition, and

at least some of the previously determined relationships correspond to an unblocked microcirculation condition; and

responsive to determining, based on said comparing, that a the microcirculation condition of the patient comprises an at least partially blocked microcirculation condition in at least a portion of blood vessels in the tissue of the patient, perform at least one of:

providing an electronic microcirculation condition indication for review by a caregiver,

causing the non-invasive physiological sensor to be configured to transmit at least a portion of the light at a different wavelength, or

applying an offset of to at least one of the measure of oxygen saturation or the other calculated parameter to compensate for the at least partially blocked microcirculation condition.

12. The method of claim 11, wherein the other calculated parameter comprises a measure of perfusion or perfusion index of the tissue of the patient.

13. The method of claim 12, wherein determining the relationship comprises:

determining a ratio of the measure of oxygen saturation to the measure of perfusion or perfusion index.

## 14

14. The method of claim 13, wherein comparing the determined relationship with at least some of the plurality of previously determined relationships:

comparing the ratio with at least some of the plurality of previously determined relationships.

15. The method of claim 13, wherein the plurality of previously determine relationships comprise a plurality of lookup curves, and wherein comparing the determined relationship with at least some of the plurality of previously determined relationships comprises:

generating a trend line based on the ratio and one or more other ratios determined based on further measures of oxygen saturation and perfusion or perfusion index obtained a different times; and

comparing the trend line to at least one lookup curve of the plurality of lookup curves.

16. The method of claim 11, wherein comparing the determined relationship with at least some of the plurality of previously determined relationships comprises:

determining one of the plurality of previously determined relationships that is most similar to the determined relationship.

17. The method of claim 11, wherein the oxygen saturation is responsive to differential absorption of hemoglobin derivatives, and wherein the at least partially blocked microcirculation condition indicates an at least partial blockage of hemoglobin.

18. A method of monitoring a patient and non-invasively determining a microcirculation condition of the patient, the method comprising:

receiving, from a non-invasive physiological sensor at a tissue site of a patient, a signal responsive to light of at least at first wavelength and a second wavelength that is transmitted by non-invasive physiological sensor and detected by the non-invasive physiological sensor after attenuation by tissue of the patient;

processing the signal to determine at least:

a first measure of oxygen saturation of the tissue of the patient at a first time,

a first other calculated parameter responsive to a physiological characteristic of the tissue of the patient at the first time,

a second measure of oxygen saturation of the tissue of the patient at a second time different from the first time, and

a second other calculated parameter responsive to a physiological characteristic of the tissue of the patient at the second time;

determining a first relationship between the first measure of oxygen saturation and the first other calculated parameter;

determining a second relationship between the second measure of oxygen saturation and the second other calculated parameter;

comparing the determined first and second relationships with at least some of a plurality of previously determined and stored relationships between measures of oxygen saturation and other calculated parameters, wherein:

at least some of the previously determined relationships correspond to an at least partially blocked microcirculation condition, and

at least some of the previously determined relationships correspond to an unblocked microcirculation condition; and

responsive to determining, based on said comparing, that a microcirculation condition of the patient comprises an

15

at least partially blocked microcirculation condition in at least a portion of blood vessels in the tissue of the patient, perform at least one of:  
providing an electronic microcirculation condition indication for review by a caregiver,  
causing the non-invasive physiological sensor to be configured to transmit at least a portion of the light at a different wavelength, or  
applying an offset of to at least one of the first measure of oxygen saturation, the second measure of oxygen saturation, the first other calculated parameter, or the second other calculated parameter to compensate for the at least partially blocked microcirculation condition.

19. The method of claim 18, wherein:  
determining the first and second relationships includes:  
    averaging the respective first and second measures of oxygen saturation to determine an average measure of oxygen saturation;  
    averaging the respective first and second other calculated parameters to determine an average other calculated parameter; and  
    determining a ratio of the average measure of the other calculated parameter to the average measure of oxygen saturation; and  
wherein comparing the determined first and second relationships with at least some of the plurality of previously determined and stored relationships includes:

16

comparing the ratio with at least some of the plurality of previously determined relationships.

20. The method of claim 18, wherein determining the first and second relationships includes:

    determining respective ratios of the respective first and second other calculated parameters to the respective first and second measures of oxygen saturation; and  
    wherein comparing the determined first and second relationships with at least some of the plurality of previously determined and stored relationships includes:  
        comparing the ratios to at least one lookup curve of the plurality of previously determined relationships.

21. The method of claim 18, wherein comparing the determined first and second relationships with at least some of the plurality of previously determined relationships comprises:

    determining one of the plurality of previously determined relationships that is most similar to at least one of the first or second determined relationships.

22. The method of claim 18, wherein the oxygen saturation is responsive to differential absorption of hemoglobin derivatives, and wherein the at least partially blocked microcirculation condition indicates an at least partial blockage of hemoglobin.

\* \* \* \* \*

专利名称(译)	用于确定微循环状态的患者监测器		
公开(公告)号	<a href="#">US10271748</a>	公开(公告)日	2019-04-30
申请号	US15/709189	申请日	2017-09-19
[标]申请(专利权)人(译)	梅西莫股份有限公司		
申请(专利权)人(译)	Masimo公司		
当前申请(专利权)人(译)	Masimo公司		
[标]发明人	AL ALI AMMAR		
发明人	AL-ALI, AMMAR		
IPC分类号	A61B5/1455 A61B5/02 A61B5/00 A61B5/024 A61B5/026		
CPC分类号	A61B5/0261 A61B5/02007 A61B5/02427 A61B5/14551 A61B5/746 A61B5/6801 A61B5/7275 A61B5/7282 A61B5/14552		
优先权	14/160316 2015-11-24 US 61/332155 2010-05-06 US		
其他公开文献	US20180055385A1		
外部链接	<a href="#">Espacenet</a>		

摘要(译)

由于生理监测传感器的放置通常位于位于身体末端的传感器位置处，微循环状态（例如血管是否被阻塞或打开）可对传感器部位处的读数产生显著影响。因此，希望提供一种能够区分血管微循环状态的患者监测器和/或生理监测传感器。在一些实施例中，患者监测器和/或传感器基于微循环状态提供警告和/或补偿测量。在一些实施例中，可由患者监测器和/或传感器实现的微循环确定过程用于确定患者的微循环状态。

