



US010098560B2

(12) **United States Patent**
Narayan et al.

(10) **Patent No.:** **US 10,098,560 B2**
(45) **Date of Patent:** **Oct. 16, 2018**

(54) **SYSTEM AND METHOD TO IDENTIFY SOURCES ASSOCIATED WITH BIOLOGICAL RHYTHM DISORDERS**

(58) **Field of Classification Search**
CPC A61B 5/02405
See application file for complete search history.

(71) Applicants: **The Regents of the University of California**, Oakland, CA (US); **Topera, Inc.**, Menlo Park, CA (US)

(56) **References Cited**

U.S. PATENT DOCUMENTS

4,421,114 A 12/1983 Berkovits et al.
4,630,204 A 12/1986 Mortara

(Continued)

FOREIGN PATENT DOCUMENTS

CN 1768342 A 5/2006
CN 1863574 A 11/2006

(Continued)

OTHER PUBLICATIONS

Ciaccio, Edward J. et al., "Development of Gradient Descent Adaptive Algorithms to Remove Common Mode Artifact for Improvement of Cardiovascular Signal Quality", *Annals of Biomedical Engineering*, vol. 35, No. 7, Jul. 2007, pp. 1146-1155.

(Continued)

Primary Examiner — Carl H Layno

Assistant Examiner — Jennifer Ghand

(74) *Attorney, Agent, or Firm* — Eleanor Musick; Scott H. Davison; Musick Davison LLP

(72) Inventors: **Sanjiv Narayan**, La Jolla, CA (US); **Carey Robert Briggs**, La Jolla, CA (US); **Ruchir Sehra**, Scottsdale, AZ (US)

(73) Assignees: **The Regents of the University of California**, Oakland, CA (US); **Topera, Inc.**, Menlo Park, CA (US); **The United States of America as Represented by the Department of Veterans Affairs**, Washington, DC (US)

(*) Notice: Subject to any disclaimer, the term of this patent is extended or adjusted under 35 U.S.C. 154(b) by 0 days.

(21) Appl. No.: **14/869,687**

(22) Filed: **Sep. 29, 2015**

(65) **Prior Publication Data**

US 2016/0015283 A1 Jan. 21, 2016

Related U.S. Application Data

(63) Continuation of application No. 14/774,120, filed as application No. PCT/US2014/029645 on Mar. 14, (Continued)

(51) **Int. Cl.**
A61B 5/024 (2006.01)
A61B 5/042 (2006.01)
(Continued)

(52) **U.S. Cl.**
CPC **A61B 5/0422** (2013.01); **A61B 5/0002** (2013.01); **A61B 5/046** (2013.01)

(57) **ABSTRACT**

A system and method are provided to define a driver of a source associated with a cardiac rhythm disorder of a human heart. A plurality of cardiac signals associated with sensors arranged spatially in relation to an area of the heart are processed to determine a sequence of arcs of rotation in relation to the sensors over a time interval. Rotational directions of the arcs of rotation in the sequence are determined. The area of the heart is identified as controlling the source when the rotational directions of the arcs of rotation in the sequence continue in a same rotational direction in excess of a threshold.

30 Claims, 9 Drawing Sheets

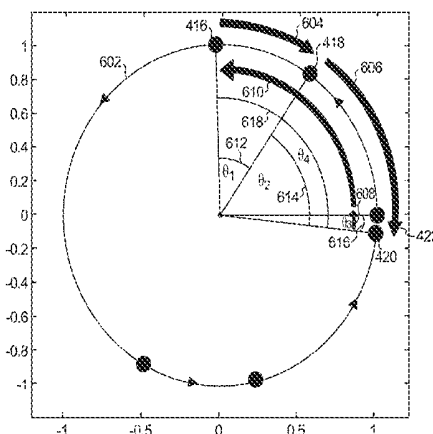

Related U.S. Application Data

2014, which is a continuation of application No. 13/844,562, filed on Mar. 15, 2013, now Pat. No. 9,332,915.

(51) **Int. Cl.**

A61B 5/00 (2006.01)

A61B 5/046 (2006.01)

(56)

References Cited

U.S. PATENT DOCUMENTS

4,754,763 A	7/1988	Doemland	6,950,696 B2	9/2005	Bjorling et al.
4,905,707 A	3/1990	Davies et al.	6,950,702 B2	9/2005	Sweeney
4,905,708 A	3/1990	Davies	6,959,212 B2	10/2005	Hsu et al.
5,029,082 A	7/1991	Shen et al.	6,975,900 B2	12/2005	Rudy et al.
5,092,341 A	3/1992	Kelen	6,978,168 B2	12/2005	Beatty et al.
5,121,750 A	6/1992	Katims	6,985,768 B2	1/2006	Hemming et al.
5,172,699 A	12/1992	Svenson et al.	7,016,719 B2	3/2006	Rudy et al.
5,178,154 A	1/1993	Ackmann et al.	7,043,292 B2	5/2006	Tarjan et al.
5,366,487 A	11/1994	Adams et al.	7,076,288 B2	7/2006	Skinner
5,427,112 A	6/1995	Noren et al.	7,117,030 B2	10/2006	Berenfeld et al.
5,433,198 A	7/1995	Desai	7,123,954 B2	10/2006	Narayan et al.
5,439,483 A	8/1995	Duong-Van	7,206,630 B1	4/2007	Tarler
5,450,846 A	9/1995	Goldreyer	7,215,993 B2	5/2007	Lin
5,458,621 A	10/1995	White et al.	7,245,962 B2	7/2007	Ciaccio et al.
5,480,422 A	1/1996	Ben-Haim	7,263,397 B2	8/2007	Hauck et al.
5,487,391 A	1/1996	Panescu	7,283,865 B2	10/2007	Noren
5,582,173 A	12/1996	Li	7,289,843 B2	10/2007	Beatty et al.
5,645,070 A	7/1997	Turcott	7,289,845 B2	10/2007	Sweeney et al.
5,657,755 A	8/1997	Desai	7,328,063 B2	2/2008	Zhang et al.
5,662,108 A	9/1997	Budd et al.	7,369,890 B2	5/2008	Lovett
5,687,737 A	11/1997	Branham et al.	7,505,810 B2	3/2009	Harlev et al.
5,718,241 A	2/1998	Ben-Haim et al.	7,515,954 B2	4/2009	Harlev et al.
5,795,303 A	8/1998	Swanson et al.	7,567,835 B2	7/2009	Gunderson et al.
5,810,740 A	9/1998	Paisner	7,580,744 B2	8/2009	Hsu
5,817,134 A	10/1998	Greenhut et al.	7,620,446 B2	11/2009	Ferek-Petric
5,819,740 A	10/1998	Muhlenberg	7,657,307 B2	2/2010	Dam et al.
5,836,889 A	11/1998	Wyborny et al.	7,729,753 B2	6/2010	Kremliovskiy et al.
5,840,025 A	11/1998	Ben-Haim	7,734,333 B2	6/2010	Ghanem et al.
5,848,972 A	12/1998	Triedman et al.	7,734,336 B2	6/2010	Ghanem et al.
5,868,680 A	2/1999	Steiner et al.	7,738,948 B2	6/2010	Rouw et al.
5,954,661 A	9/1999	Greenspon et al.	7,742,812 B2	6/2010	Ghanem et al.
5,954,665 A	9/1999	Ben-Haim	7,751,882 B1	7/2010	Helland
6,052,618 A	4/2000	Dahlke et al.	7,761,142 B2	7/2010	Ghanem et al.
6,066,094 A	5/2000	Ben-Haim	7,761,150 B2	7/2010	Ghanem et al.
6,097,983 A	8/2000	Strandberg	7,769,452 B2	8/2010	Ghanem et al.
6,112,117 A	8/2000	Kenknight et al.	7,801,594 B1	9/2010	Higham
6,115,628 A	9/2000	Stadler et al.	7,907,993 B2	3/2011	Ghanem et al.
6,188,924 B1	2/2001	Swanson et al.	7,907,994 B2	3/2011	Stolarski et al.
6,208,888 B1	3/2001	Yonce	7,930,018 B2	4/2011	Harlev et al.
6,236,883 B1	5/2001	Ciaccio et al.	7,930,020 B2	4/2011	Zhang et al.
6,251,125 B1	6/2001	Kenknight et al.	7,953,475 B2	5/2011	Harlev et al.
6,256,540 B1	7/2001	Panescu et al.	7,962,202 B2	6/2011	Bhunia
6,301,496 B1	10/2001	Reisfeld	8,050,732 B2	11/2011	Desai
6,324,421 B1	11/2001	Stadler et al.	8,050,751 B2	11/2011	Zhang et al.
6,360,121 B1	3/2002	Shoda	8,050,757 B2	11/2011	Hsu
6,397,100 B2	5/2002	Stadler et al.	8,095,205 B2	1/2012	Bhunia et al.
6,438,406 B2	8/2002	Yonce	8,095,206 B2	1/2012	Ghanem et al.
6,438,409 B1	8/2002	Malik et al.	8,160,684 B2	4/2012	Ghanem et al.
6,449,503 B1	9/2002	Hsu	8,165,666 B1	4/2012	Briggs et al.
6,510,339 B2	1/2003	Kovtun et al.	8,165,671 B2	4/2012	Freeman et al.
6,522,905 B2	2/2003	Desai	8,175,702 B2	5/2012	Efimov et al.
6,539,256 B1	3/2003	Kenknight et al.	8,306,618 B2	11/2012	Ghanem et al.
6,542,773 B2	4/2003	Dupree et al.	8,315,697 B2	11/2012	Hsu
6,553,251 B1	4/2003	Lähdesmäki	8,340,766 B2	12/2012	Ryu et al.
6,584,345 B2	6/2003	Govari	8,386,024 B2	2/2013	Gunderson et al.
6,725,085 B2	4/2004	Schwartzman et al.	8,435,185 B2	5/2013	Ghanem et al.
6,738,655 B1	5/2004	Sen et al.	8,489,171 B2	7/2013	Hauck et al.
6,788,969 B2	9/2004	Dupree et al.	8,521,266 B2	8/2013	Narayan et al.
6,847,839 B2	1/2005	Ciaccio et al.	8,588,885 B2	11/2013	Hall et al.
6,856,830 B2	2/2005	He	8,594,777 B2	11/2013	Briggs et al.
6,889,081 B2	5/2005	Hsu	8,639,325 B2	1/2014	Efimov et al.
6,892,091 B1	5/2005	Ben-Haim et al.	8,676,303 B2	3/2014	Narayan
6,920,350 B2	7/2005	Xue et al.	8,700,140 B2	4/2014	Narayan et al.
6,941,166 B2	9/2005	MacAdam et al.	8,715,199 B1	5/2014	Macneil et al.
			8,812,074 B2	8/2014	Kordis et al.
			8,838,222 B2	9/2014	Narayan et al.
			8,838,223 B2	9/2014	Narayan et al.
			8,868,169 B2	10/2014	Narayan et al.
			9,031,642 B2	5/2015	Ghosh
			9,050,006 B2	6/2015	Narayan et al.
			9,055,876 B2	6/2015	Narayan et al.
			9,055,877 B2	6/2015	Narayan et al.
			9,055,878 B2	6/2015	Narayan et al.
			9,089,269 B2	7/2015	Narayan et al.
			9,107,600 B2	8/2015	Narayan et al.
			9,220,427 B2	12/2015	Narayan et al.
			9,241,667 B2	1/2016	Narayan et al.
			9,282,910 B2	3/2016	Narayan et al.
			9,332,915 B2	5/2016	Narayan et al.

(56)

References Cited

U.S. PATENT DOCUMENTS

9,375,156 B2 6/2016 Narayan et al.
 9,380,950 B2 7/2016 Narayan et al.
 9,392,948 B2 7/2016 Briggs et al.
 9,393,425 B2 7/2016 Narayan
 9,398,860 B2 7/2016 Macneil et al.
 9,398,883 B2 7/2016 Narayan et al.
 9,408,536 B2 8/2016 Narayan et al.
 9,439,573 B2 9/2016 Narayan et al.
 9,468,387 B2 10/2016 Narayan et al.
 9,549,684 B2 1/2017 Narayan et al.
 9,668,666 B2 6/2017 Narayan et al.
 2002/0010392 A1 1/2002 Desai
 2002/0016548 A1 2/2002 Stadler et al.
 2003/0018277 A1 1/2003 He
 2003/0083587 A1 5/2003 Ferek-Petric
 2003/0236466 A1 12/2003 Tarjan
 2004/0073262 A1 4/2004 Lovett
 2004/0093035 A1 5/2004 Schwartz et al.
 2004/0243014 A1 12/2004 Lee et al.
 2005/0137638 A1 6/2005 Yonce et al.
 2005/0148892 A1 7/2005 Desai
 2005/0203502 A1 9/2005 Boveja et al.
 2006/0084970 A1 4/2006 Beatty et al.
 2006/0161069 A1 7/2006 Li
 2006/0161206 A1 7/2006 Efimov et al.
 2007/0016261 A1 1/2007 Dong et al.
 2007/0055167 A1 9/2007 Bullinga
 2007/0208260 A1 9/2007 Afonso
 2007/0208263 A1 9/2007 John et al.
 2007/0232948 A1 10/2007 Stadler et al.
 2007/0299351 A1 12/2007 Harlev et al.
 2008/0097539 A1 4/2008 Belalcazar et al.
 2008/0109041 A1 5/2008 de Voir
 2008/0114258 A1 5/2008 Zhang et al.
 2008/0188765 A1 8/2008 Stolarski et al.
 2008/0208012 A1 8/2008 Ali
 2009/0069704 A1 3/2009 MacAdam et al.
 2009/0099468 A1 4/2009 Thiagalingam et al.
 2009/0099618 A1 4/2009 Rouso et al.
 2009/0112106 A1 4/2009 Zhang
 2009/0112110 A1 4/2009 Zhang et al.
 2009/0112199 A1 4/2009 Zhang et al.
 2009/0131760 A1 5/2009 Ali et al.
 2009/0163968 A1 6/2009 Donofrio
 2009/0177071 A1 7/2009 Harlev et al.
 2009/0177072 A1 7/2009 Harlev et al.
 2009/0259266 A1 10/2009 Zhang et al.
 2009/0299203 A1 12/2009 de Voir et al.
 2010/0026543 A1 2/2010 Tsai et al.
 2010/0204592 A1 8/2010 Hatib et al.
 2010/0217143 A1 8/2010 Whittington et al.
 2010/0239627 A1 9/2010 Zhang et al.
 2010/0249627 A1 9/2010 Zhang et al.
 2010/0298729 A1 11/2010 Zhang et al.
 2010/0305456 A1 12/2010 Brainard, II
 2010/0324435 A1 12/2010 Higham
 2011/0077540 A1 3/2011 Belalcazar
 2011/0087121 A1 4/2011 Zhang et al.
 2011/0112425 A1 5/2011 Muhlsteff et al.
 2011/0130801 A1 6/2011 Maskara et al.
 2011/0196249 A1 8/2011 Staeuber et al.
 2011/0257547 A1 10/2011 Zhang et al.
 2011/0282227 A1 11/2011 Zhang
 2012/0184858 A1 7/2012 Harlev et al.
 2012/0232417 A1 9/2012 Zhang et al.
 2013/0006131 A1 1/2013 Narayan et al.
 2013/0150740 A1 6/2013 Narayan et al.
 2013/0150742 A1 6/2013 Briggs et al.
 2013/0245474 A1 9/2013 Nicolson et al.
 2013/0324871 A1 12/2013 Dubois et al.
 2013/0331718 A1 12/2013 Narayan et al.
 2013/0345577 A1 12/2013 Thakur et al.
 2014/0005562 A1 1/2014 Bunch et al.
 2014/0228696 A1 8/2014 Narayan et al.
 2014/0235988 A1 8/2014 Ghosh

2014/0276152 A1 9/2014 Narayan et al.
 2014/0336520 A1 11/2014 Zeng et al.
 2014/0371609 A1 12/2014 Narayan et al.
 2014/0371613 A1 12/2014 Narayan et al.
 2015/0038861 A1 2/2015 Narayan et al.
 2015/0196212 A1 7/2015 Narayan et al.
 2015/0257710 A1 9/2015 Narayan et al.
 2015/0289807 A1 10/2015 Narayan et al.
 2015/0313548 A1 11/2015 Narayan et al.
 2016/0015283 A1 1/2016 Narayan et al.
 2016/0022163 A1 1/2016 Narayan et al.
 2016/0095531 A1 4/2016 Narayan et al.
 2016/0166167 A1 6/2016 Narayan et al.
 2016/0278657 A1 9/2016 Narayan et al.
 2016/0302734 A1 10/2016 Narayan
 2016/0360983 A1 12/2016 Narayan et al.
 2016/0374571 A1 12/2016 Narayan et al.
 2017/0007176 A1 1/2017 Narayan et al.

FOREIGN PATENT DOCUMENTS

CN 101292870 A 10/2008
 CN 101461711 A 6/2009
 EP 284685 10/1988
 EP 2269691 A2 1/2011
 EP 1808124 B1 4/2011
 JP H09215667 A 8/1997
 WO 1994021168 9/1994
 WO 1996025096 A1 8/1996
 WO 1996032885 A1 10/1996
 WO 1996032897 A1 10/1996
 WO 1996039929 A1 12/1996
 WO 1997024983 A2 7/1997
 WO 2000045700 A1 8/2000
 WO 2005035046 A2 4/2005
 WO 2005115232 A1 12/2005
 WO 2007078421 A2 7/2007
 WO 2007106829 A2 9/2007
 WO 2008035070 A2 3/2008
 WO 2008035070 A3 3/2008

OTHER PUBLICATIONS

Holm, M. et al., "A New Method for Analysis of Atrial Activation During Chronic Atrial Fibrillation in Man", IEEE Transactions on Biomedical Engineering, vol. 43, No. 2, Feb. 1, 1996, pp. 198-210.
 Houben, R.P.M., et al., "Processing of Intracardiac Electrograms in Atrial Fibrillation", IEEE Engineering in Medicine and Biology Magazine, Nov./Dec. 2006, pp. 40-51.
 Houben, R.P.M., et al., "Automatic mapping of human atrial fibrillation by template matching", Heart Rhythm, vol. 3, No. 10, Oct. 1, 2006, pp. 1221-1228.
 Kadish, A., et al., "Characterization of fibrillatory rhythms by ensemble vector directional analysis", Am J Physiol.—Heart Circ. Physiol., vol. 285, Oct. 2003, pp. H1705-H1719.
 Kalifa, J. et al. "Mechanisms of wave fractionation at boundaries of high-frequency excitation in the posterior left atrium of the isolated sheep heart during atrial fibrillation," Circulation, vol. 113, No. 5, Feb. 7, 2006, pp. 626-633.
 Lin, Y-J, et al., "Electrophysiological Characteristics and Catheter Ablation in Patients With Paroxysmal Right Atrial Fibrillation", Circulation, Sep. 20, 2005; 112(12): 1692-1700, Epub Sep. 12, 2005.
 Masse, S., et al., "Wave similarity of human ventricular fibrillation from bipolar electrograms", Eurospace (2007) vol. 9, pp. 10-19.
 Nademanee, Koonlawee, et al., "A new approach for catheter ablation of atrial fibrillation: mapping of the electrophysiologic substrate", J. Amer.Coll.Cardiol., vol. 43, No. 11, Jun. 2, 2004, pp. 2044-2053.
 Narayan, S.M., et al., "Dynamics factors preceding the initiation of atrial fibrillation in humans", Heart Rhythm, vol. 5, No. 6, Jun. 1, 2008, pp. S22-S25.
 Saksena, S., et al., "Regional Endocardial Mapping of Spontaneous and Induced Atrial Fibrillation in Patients With Heart Disease and Refractory Atrial Fibrillation", Am J Cardiol, 1999; 84:880-889.

(56)

References Cited

OTHER PUBLICATIONS

Sornborger, Andrew, et al., "Extraction of Periodic Multivariate Signals: Mapping of Voltage-Dependent Dye Fluorescence in the Mouse Heart", *IEEE Transactions on Medical Imaging*, vol. 22, No. 12, Dec. 2003, pp. 1537-1549.

Sun, Yan, et al., "Characteristic wave detection in ECG signal using morphological transform", *BMC Cardiovascular Disorders*, vol. 5, No. 28, 2005.

Tai, Dean C.S., et al., "Correction of motion artifact in transmembrane voltage-sensitive fluorescent dye emission in hearts", *Am. J. Physiol. Heart Circ. Physiol.*, vol. 287, 2004, pp. H985-H993.

Ulphani, J.S., et al., "Frequency gradients during two different forms of fibrillation in canine atria", *Heart Rhythm*, vol. 4, No. 10, Oct. 2007, pp. 1315-1323.

Umapathy, K, et al. "Spatiotemporal Frequency Analysis of Ventricular Fibrillation in Implanted Human Hearts," *IEEE Transactions on Biomedical Engineering*, vol. 56, No. 2, Feb. 1, 2009, pp. 328-335.

Yenn-Jiang L, et al. "Electrophysiological Mechanisms and Catheter Ablation of Complex Atrial Arrhythmias from Crista Terminalis: Insight from Three-Dimensional Noncontact Mapping," *Pacing and Clinical Electrophysiology*, vol. 27, No. 9, Sep. 1, 2004, pp. 1231-1239.

PCT/US2009/060178: International Preliminary Report on Patentability, dated Apr. 12, 2011, 10 pages.

EP09819953: Supplementary European Search Report and European Search Opinion, dated Feb. 7, 2012, 5 pages.

PCT/US2011/031468: International Preliminary Report on Patentability, dated Oct. 9, 2012, 8 pages.

PCT/US2011/031470: International Preliminary Report on Patentability, dated Oct. 9, 2012, 7 pages.

PCT/US2012/029935: International Search Report and Written Opinion, dated Nov. 8, 2012, 9 pages.

EP12711553: Supplementary European Search Report and European Search Opinion, dated Sep. 11, 2013, 7 pages.

PCT/US2012/036157: International Preliminary Report on Patentability, dated Nov. 5, 2013, 8 pages.

PCT/US2012/068639: International Preliminary Report on Patentability, dated Jun. 10, 2014, 6 pages.

PCT/US2012/068640: International Preliminary Report on Patentability, dated Jun. 10, 2014, 5 pages.

PCT/US/2014/029645 International Search Report and Written Opinion, dated Aug. 18, 2014, 17 pages.

PCT/US2014/029616 International Search Report and Written Opinion, dated Sep. 18, 2014, 9 pages.

EP12855266.8: Supplementary European Search Report & European Search Opinion, dated Jun. 2, 2015, 9 pages.

EP12855738.6: Supplementary European Search Report & European Search Opinion, dated Jun. 5, 2015, 9 pages.

Eckman, et al., "Recurrence Plots of dynamical systems," *Europhys. Lett.*, 4 (3), Nov. 1, 1987 pp. 973-977.

English-language translation of Chinese patent publication No. CN 101461711A, published Jun. 24, 2009.

EP12779506.0: Supplementary European Search Report & European Search Opinion, dated Nov. 18, 2014, 8 pages.

EP147665096.4 Supplementary European Search Report & European Search Opinion, dated Oct. 21, 2016, 6 pages.

EP15192804.1 Supplementary European Search Report, dated Feb. 18, 2016, 7 pages.

Jung, TP et al, Removing Electroencephalographic Artifacts by Blind Source Separation, *Psychophysiology*, 37.02 (2000): 163-178.

PCT/US2015/023929, International Search Report and Written Opinion, dated Jul. 9, 2015, 8 pages.

PCT/US2015/046742 International Search Report and Written Opinion; dated Dec. 1, 2015, 5 pages.

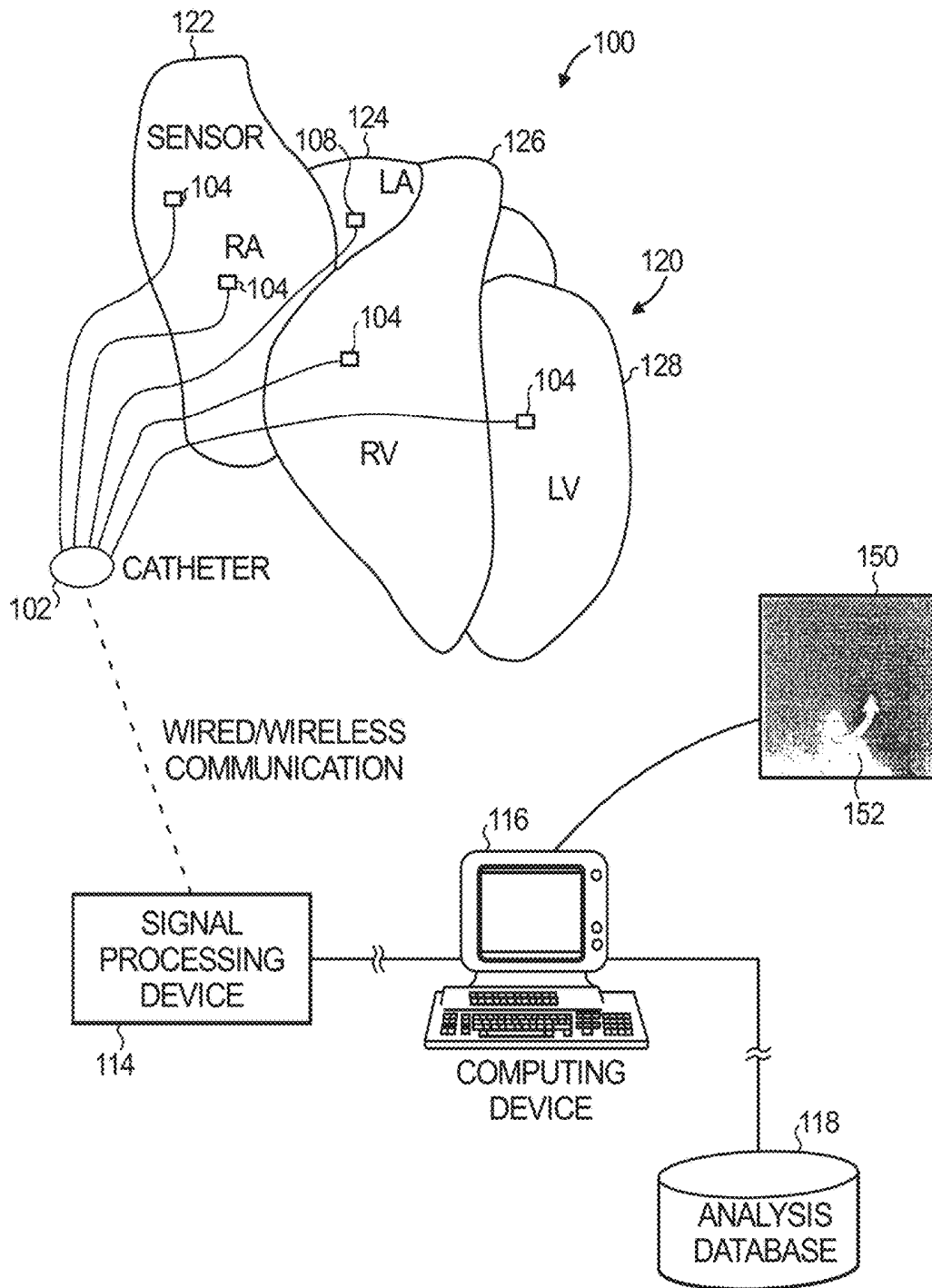

Fig. 1

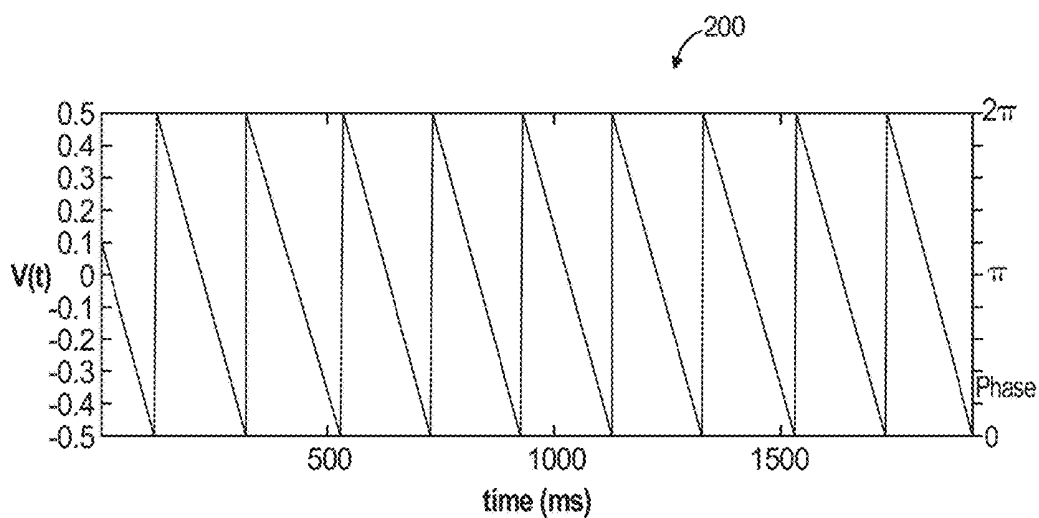

Fig. 2

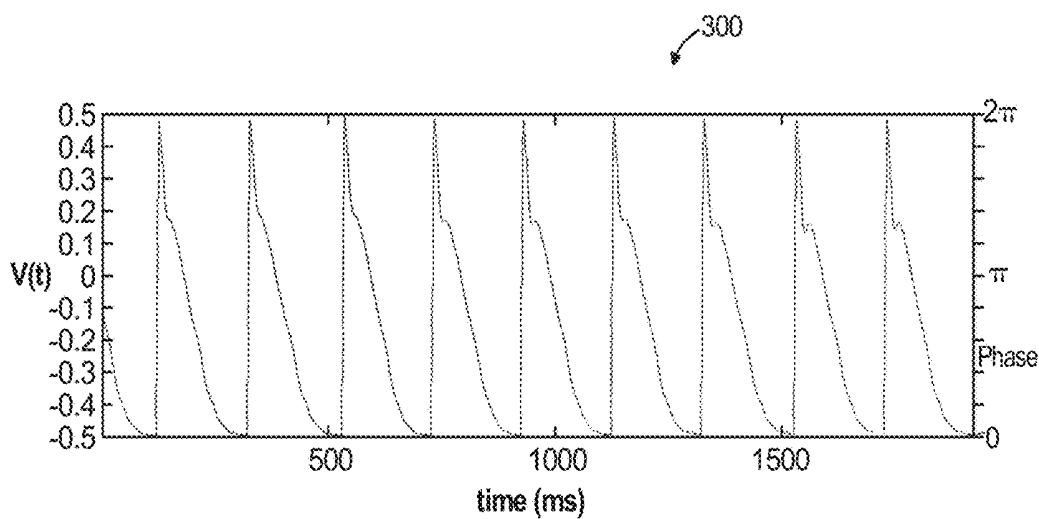

Fig. 3

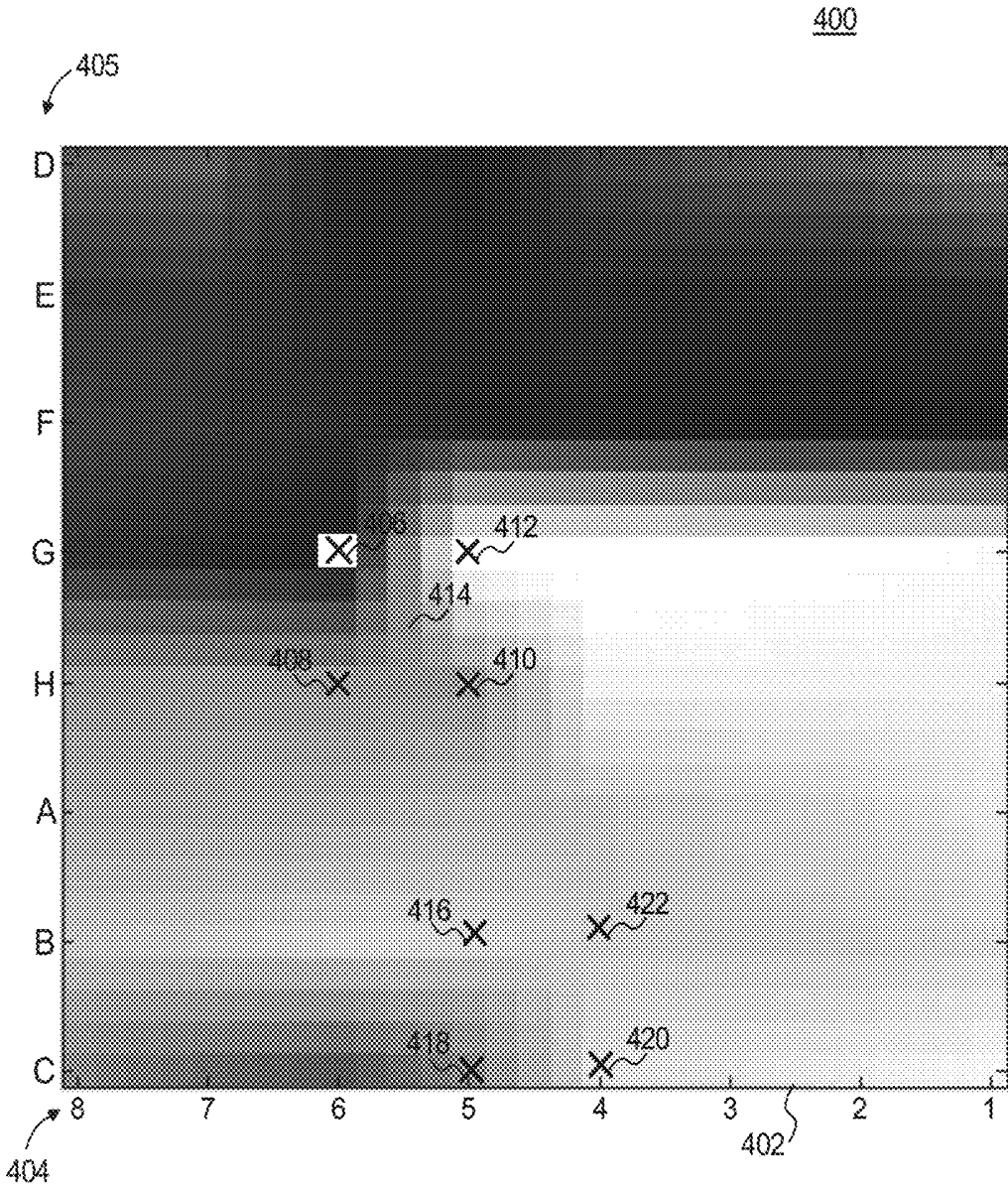

Fig. 4

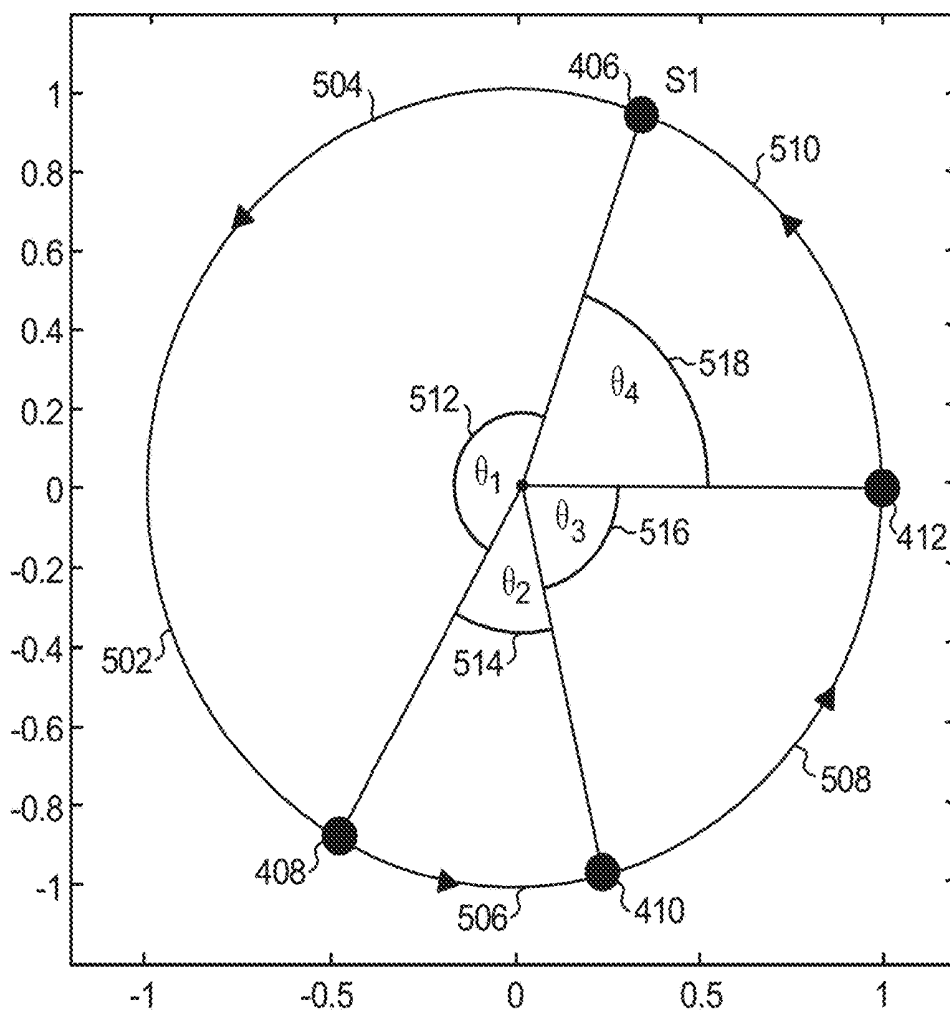

Fig. 5

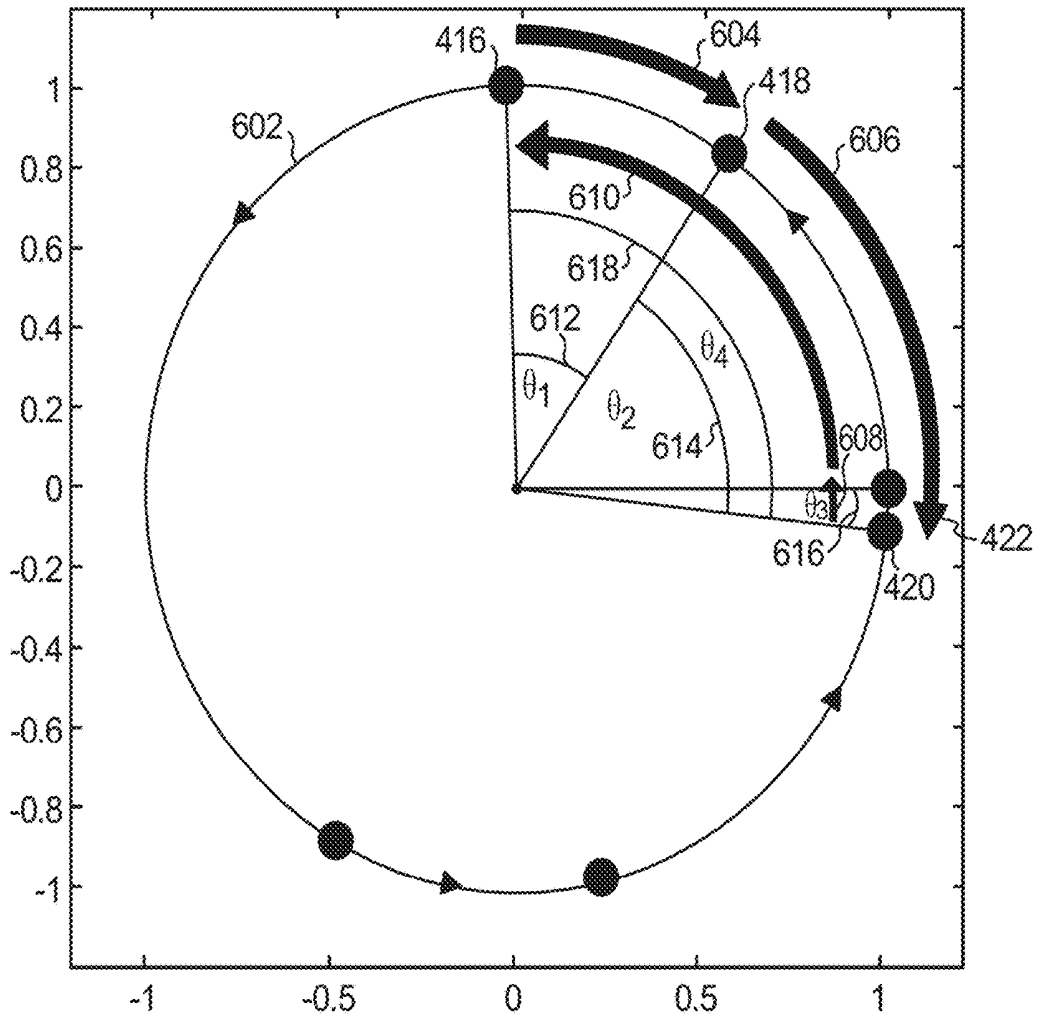

Fig. 6

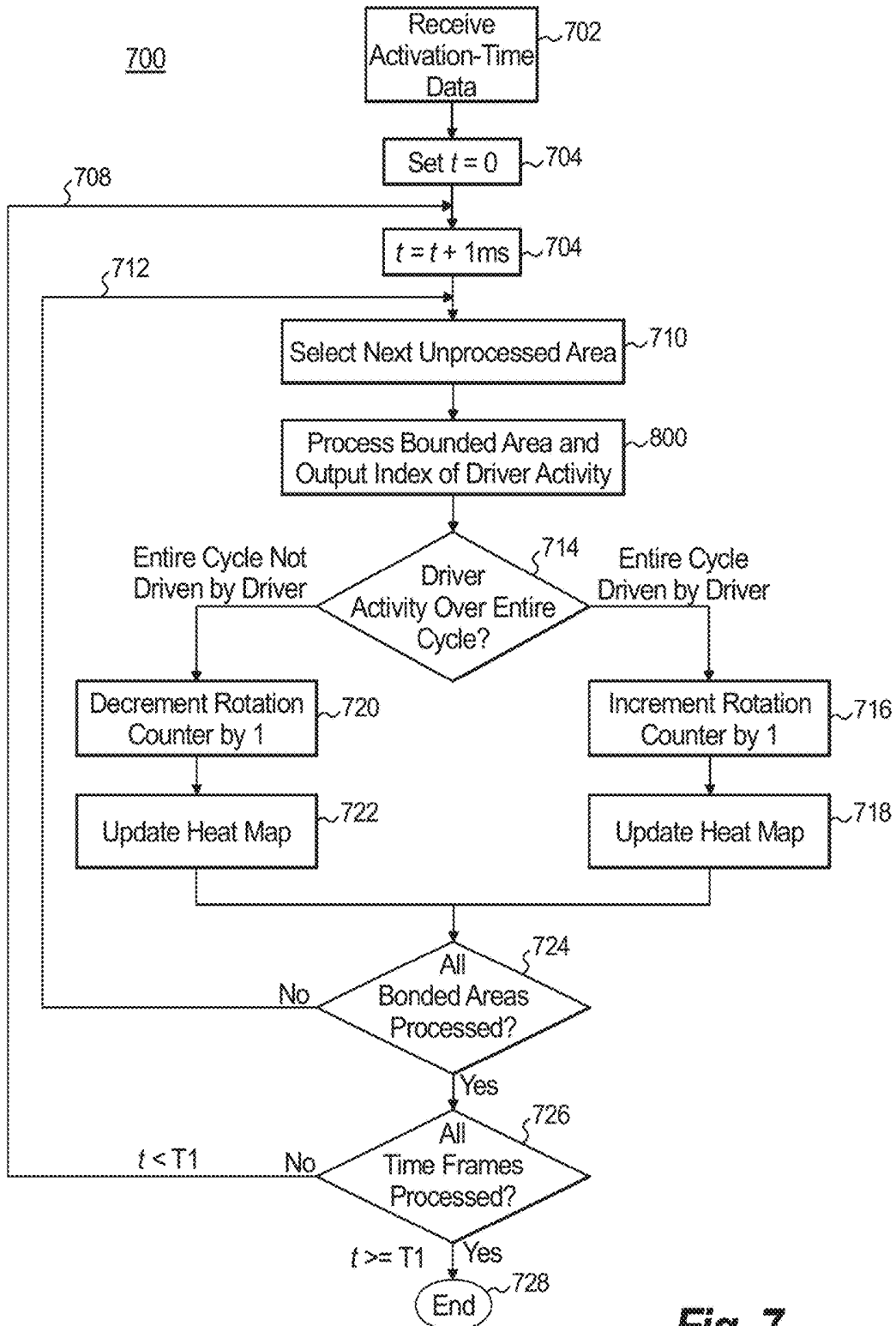

Fig. 7

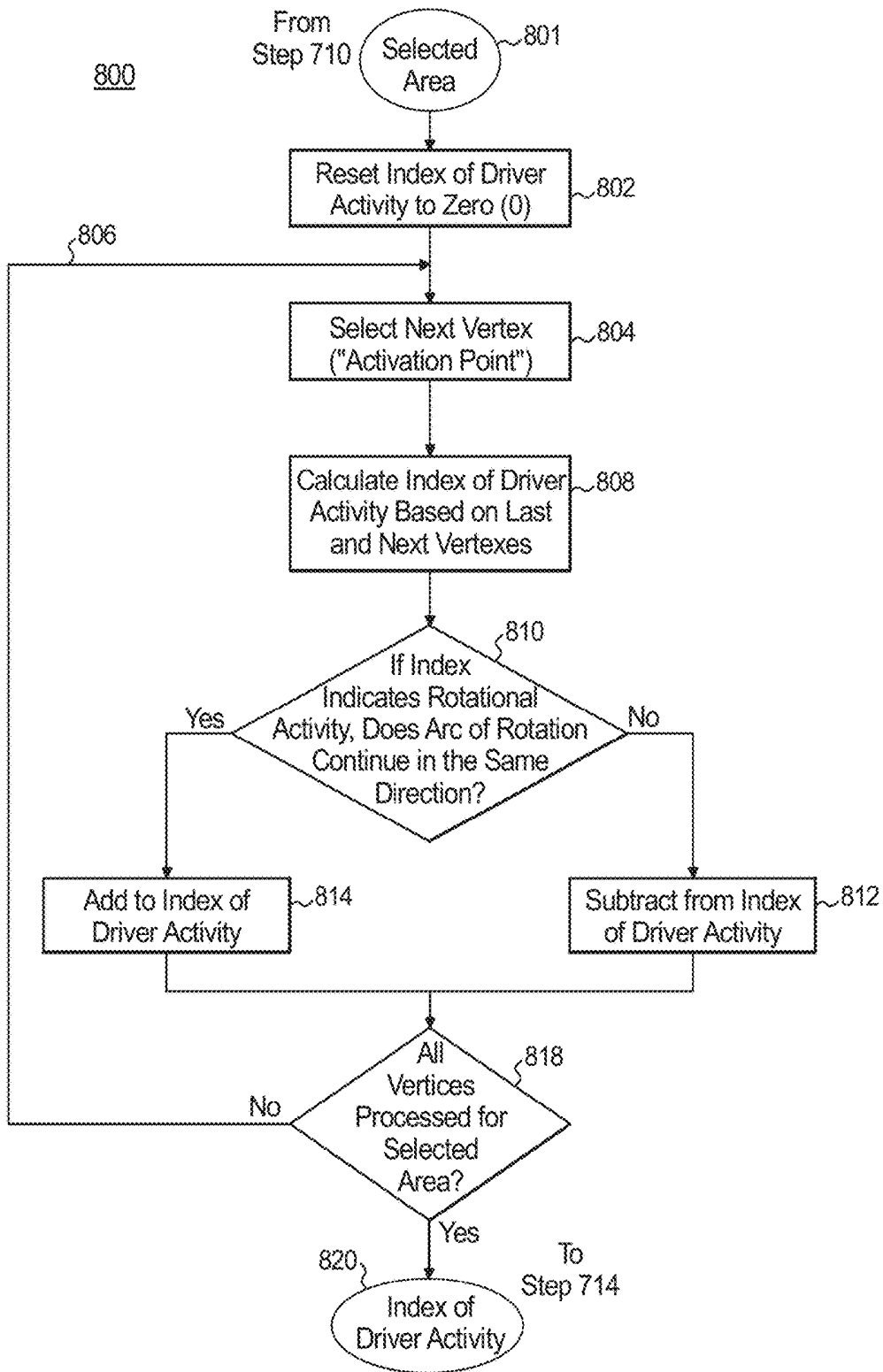

Fig. 8

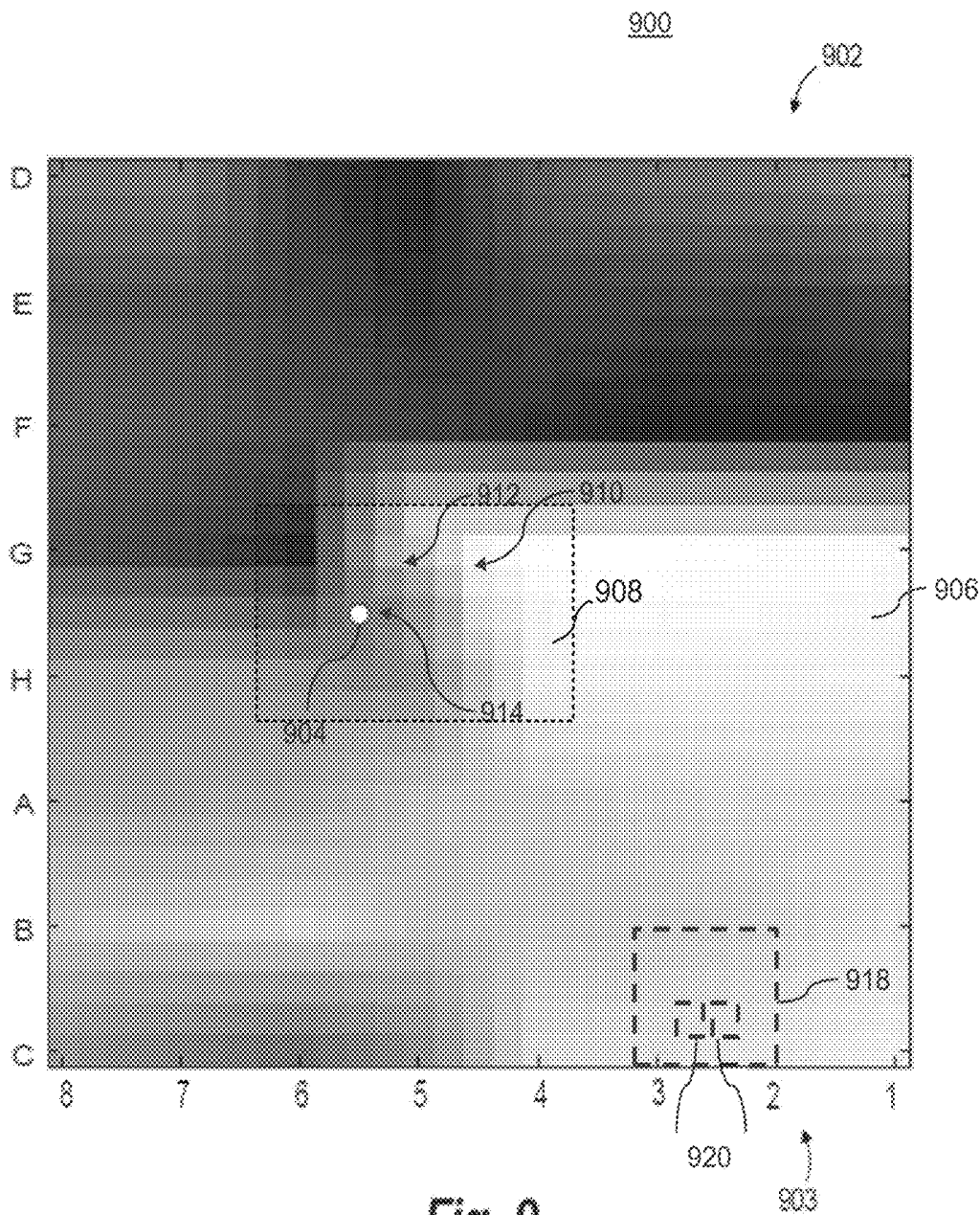

Fig. 9

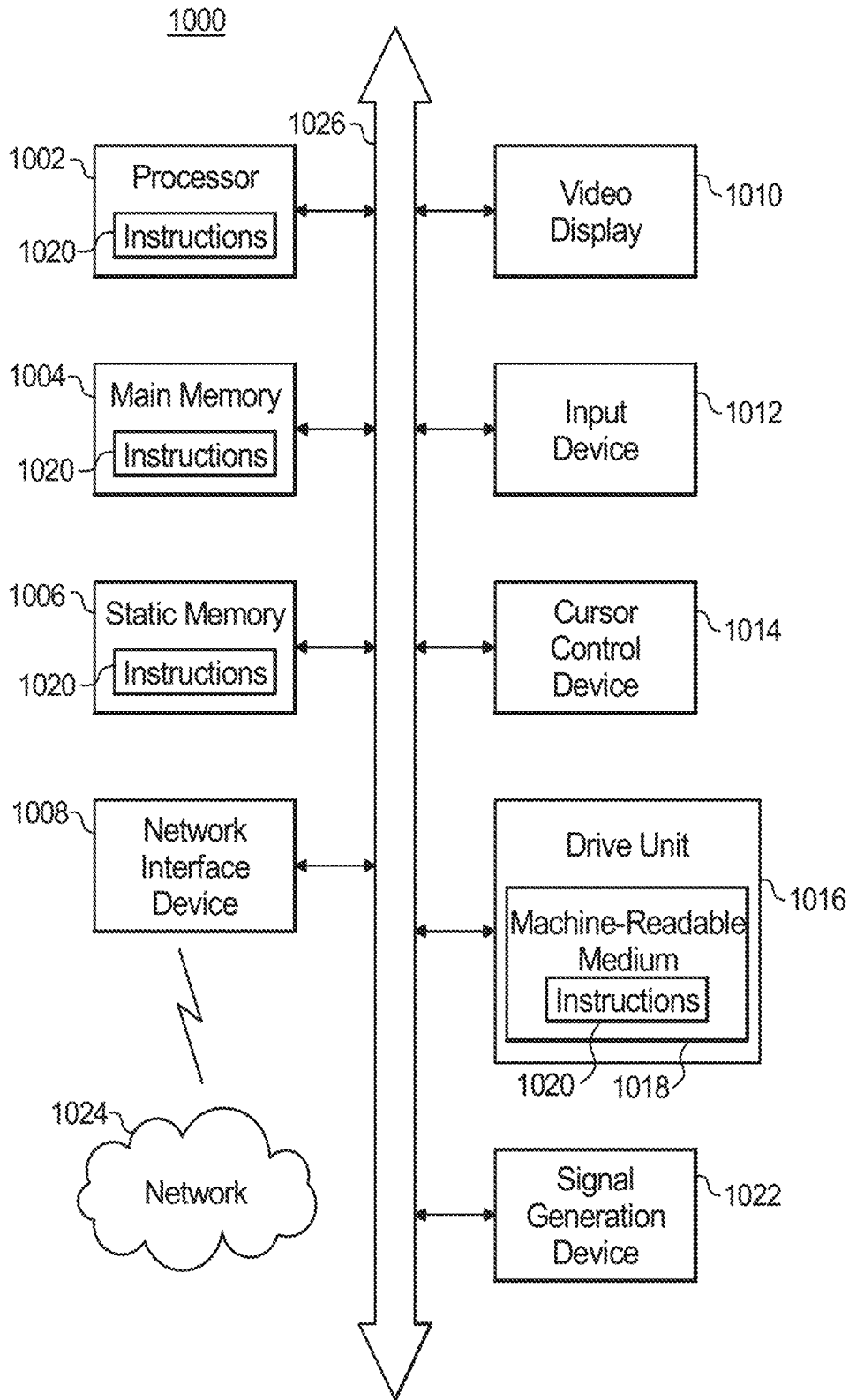

Fig. 10

SYSTEM AND METHOD TO IDENTIFY SOURCES ASSOCIATED WITH BIOLOGICAL RHYTHM DISORDERS

RELATED APPLICATIONS

This application is a continuation of application Ser. No. 14/774,120, filed Sep. 9, 2015, which is a 371 national stage filing of International Application No. PCT/US2014/029645, filed Mar. 14, 2014, which claims the benefit of the priority of U.S. application Ser. No. 13/844,562, now U.S. Pat. No. 9,332,915, filed Mar. 15, 2013, which is incorporated herein by reference in its entirety.

GOVERNMENT RIGHTS

This invention was made with government support under Grants R01 HL83359 and HL103800 from the National Institutes of Health. The government has certain rights in the invention.

BACKGROUND

Field of the Disclosure

The present application relates generally to biological rhythm disorders. More specifically, the present application is directed to a system and method to define drivers of sources associated with biological rhythm disorders, such as heart rhythm disorders.

Brief Discussion of Related Art

Heart (cardiac) rhythm disorders are common and represent significant causes of morbidity and death throughout the world. Malfunction of the electrical system in the heart represents a proximate cause of heart rhythm disorders. Heart rhythm disorders exist in many forms, of which the most complex and difficult to treat are atrial fibrillation (AF), ventricular tachycardia (VT) and ventricular fibrillation (VF). Other rhythm disorders, which are easier to treat, but which may also be clinically significant, include atrial tachycardia (AT), supraventricular tachycardia (SVT), atrial flutter (AFL), supraventricular ectopic complexes/beats (SVE) and premature ventricular complexes/beats (PVC). While under normal conditions the sinus node keeps the heart in sinus rhythm, under certain conditions rapid activation of the normal sinus node can cause inappropriate sinus tachycardia or sinus node reentry, both of which also represent heart rhythm disorders.

Previously, treatment of heart rhythm disorders—particularly complex rhythm disorders of AF, VF and polymorphic VT—has been difficult because the location in the heart that harbors the source of the heart rhythm disorder could not be identified. There have been various theories of how complex rhythm disorders function and clinical applications for treating these complex rhythm disorders. However, none of the applications proved fruitful in the treatment of complex rhythm disorders.

Recently, there has been a breakthrough discovery that for the first time identified sources associated with complex heart rhythm disorders. This technological breakthrough successfully reconstructed cardiac activation information (onset times) in signals obtained from electrodes of catheters introduced into patients' heart to identify rotational activation patterns (rotational sources) or centrifugal patterns (focal sources) that cause a large percentage of the heart rhythm disorders worldwide. Treatment of the heart rhythm disorders can thus be targeted to these rotational or focal

sources in the patients' heart to eliminate the heart rhythm disorders. Such treatment can be successfully delivered by ablation, for example.

While a rotational or focal source of a complex heart rhythm disorder can be identified as described above, the inner mechanism of the source—i.e., the core of the rotational source (its likely center of rotation), or origin of a focal source—are not well defined. In some instances, a rotational source may have one or more diffuse sections (activation wave fronts) that generally appear to rotate around a subjective rotation center, but tend to spread out diffusely about a section of the patient's heart. While the diffuse activation wave fronts are associated with the source of the complex rhythm disorder, they may contribute insignificantly to driving the heart rhythm disorder than one or more other activation wave fronts of the rotational source. Similarly, the core of a centrifugally emanating focal source of a complex rhythm disorder has not been well defined.

It has thus far been undefined how to identify the core of a rotational source in contrast to an insignificant 'passive' rotation that is not a source of the heart rhythm disorder, or how to identify the origin of a true focal source in contrast to an occasional focal activation that can be secondary to a complex rhythm disorder, rather than its source.

There are no known systems or methods to define the core of a rotational source or the origin of a focal source associated with a heart rhythm disorder.

SUMMARY

In accordance with an embodiment or aspect, a method of identifying a driver of a source associated with a heart rhythm disorder is disclosed. Data is accessed from a plurality of sensors representing biological activity in the heart. A local first region of the heart that has repeating activation and that controls a second distant region of the heart for at least a predetermined number of beats is identified. The first local region is assigned as a driver of a source of the heart rhythm disorder, the source including the first local region and the second distant region.

In accordance with another embodiment or aspect, a system of identifying a driver of a source associated with a heart rhythm disorder is disclosed. The system includes a processor and a storage medium storing instructions that, when executed by the processor, cause the processor to perform certain operations. The operations include accessing data from a plurality of sensors representing biological activity in the heart. The operations also include identifying a local first region of the heart that has repeating activation and that controls a second distant region of the heart for at least a predetermined number of beats. The operations further include assigning the first local region as a driver of a source of the heart rhythm disorder, the source including the first local region and the second distant region.

In accordance with yet another embodiment or aspect, a method of identifying an area of a human heart associated with controlling a source of a cardiac rhythm disorder is disclosed. A plurality of cardiac signals, associated with sensors arranged spatially in relation to the area of the heart, is processed to determine at least one sequence of activation in relation to the sensors over a time interval. A rotational direction of the at least one sequence of activation is determined. The area of the heart is identified as associated with controlling the source when the at least one sequence of activation continues to rotate in the rotational direction over the time interval.

In accordance with a further embodiment or aspect, a system to identify an area of a human heart associated with controlling a source of a cardiac rhythm disorder is disclosed. The system includes a processing device and a memory device storing instructions that, when executed by the processing device, cause the processing device to perform certain operations. The operations include processing a plurality of cardiac signals associated with sensors arranged spatially in relation to the area of the heart to determine at least one sequence of activation in relation to the sensors over a time interval. The operations also include determining a rotational direction of the at least one sequence of activation. The operations further include identifying the area of the heart as associated with controlling the source when the at least one sequence of activation continues to rotate in the rotational direction over the time interval.

In accordance with still another embodiment or aspect, a method to define a driver of a source associated with a cardiac rhythm disorder of a human heart is disclosed. A plurality of cardiac signals associated with sensors arranged spatially in relation to an area of the heart is processed to determine a sequence of arcs of rotation in relation to the sensors over a time interval. Rotational directions of the arcs of rotation in the sequence are determined. The area of the heart is identified as a driver of the source when the rotational directions of the arcs of rotation in the sequence continue in a same rotational direction in excess of a threshold.

In accordance with still a further embodiment or aspect, a system to define a driver of a source associated with a cardiac rhythm disorder of a human heart is disclosed. The system includes a processing device and a memory device storing instructions that, when executed by the processing device, cause the processing device to perform certain operations. The operations include processing a plurality of cardiac signals associated with sensors arranged spatially in relation to an area of the heart to determine a sequence of arcs of rotation in relation to the sensors over a time interval. The operations also include determining rotational directions of the arcs of rotation in the sequence. The operations further include identifying the area of the heart as a driver of the source when the rotational directions of the arcs of rotation in the sequence continue in a same rotational direction in excess of a threshold.

These and other purposes, goals and advantages of the present application will become apparent from the following detailed description read in connection with the accompanying drawings.

BRIEF DESCRIPTION OF THE DRAWINGS

Some embodiments or aspects are illustrated by way of example and not limitation in the figures of the accompanying drawings in which like numbers refer to like parts and in which:

FIG. 1 illustrates a system to identify rotational patterns or centrifugal patterns indicating activation emanation from localized sources for heart rhythm disorders;

FIG. 2 illustrates an example phase-time curve related to electrical signals sensed by a sensor positioned in relation to a heart illustrated in FIG. 1;

FIG. 3 illustrates another example phase-time curve related to electrical signals sensed by a sensor positioned in relation to the heart illustrated in FIG. 1;

FIG. 4 illustrates a grid with sensing elements related to locations of sensors illustrated in FIG. 1;

FIG. 5 illustrates a first example unit circle showing sensor elements illustrated in FIG. 4 with a first set of phase values;

FIG. 6 illustrates a second example unit circle showing the sensor elements illustrated in FIG. 4 with a second set of different phase values;

FIG. 7 illustrates a flowchart that shows an example method for summing (counting) indexes of rotational activity or centrifugal activation associated with a localized driver associated with areas of the grid illustrated in FIG. 4 over a time interval;

FIG. 8 illustrates a flowchart that shows an example method for summing an index of driver activity within an area of the grid illustrated in FIG. 7;

FIG. 9 illustrates a heat map, which indicates the persistence of a rotational driver (illustrated) or focal driver associated with a source of the heart rhythm disorder, and which is superimposed on an activation propagation map; and

FIG. 10 illustrates a block diagram of an illustrative embodiment of a general computer system.

DETAILED DESCRIPTION

A system and method for defining drivers of sources associated with heart rhythm disorders are disclosed herein. In the following description, for the purposes of explanation, numerous specific details are set forth in order to provide a thorough understanding of example embodiments or aspects. It will be evident, however, to one skilled in the art, that an example embodiment may be practiced without all of the disclosed specific details.

The present disclosure is applicable to defining various drivers of sources associated with heart rhythm disorders. Drivers may be represented by persistent rotational activation around a center that may show movement ('meander' or 'precession'), or persistently repetitive activation from an origin. The disclosure can also be applied to other biological rhythm disorders, such as neurological seizures, esophageal spasms, bladder instability, irritable bowel syndrome, and other biological disorders for which biological activation information can be reconstructed to permit determination, diagnosis, and/or treatment of the cause or source of the disorders. It is particularly useful, however, in complex rhythm disorders which result in complex activation patterns, and especially useful in complex rhythm disorders of the heart such as atrial fibrillation, ventricular fibrillation and others, in order to find the driver(s) associated with source(s) of the complex rhythm disorders such that they can be treated with expediency.

Complex heart rhythm disorders, including but not limited to atrial fibrillation, polymorphic atrial tachycardia, ventricular fibrillation, polymorphic ventricular tachycardia and others, typically result in activation patterns that are extremely difficult to decipher.

A novel concept is that activation from a localized region of the heart must activate surrounding tissue during the heart rhythm disorder by definition, even for complex heart rhythm disorders. This control may proceed via a centrifugal activation from the local region to surrounding tissue, or by rotational (rotor) activation from the local region to surrounding tissue. The localized region (driver) for complex rhythm disorders generally occupies an area. This disclosure describes for the first time that the driver within a localized region may demonstrate activation sequences that are rotational or centrifugal, which may affect or control a remote region of the heart.

Thus, to identify or define the local region of a complex heart rhythm disorder, it is essential not just to identify its rotational or centrifugal driver, but it is also necessary to ensure that the driver controls activation in a distant region of the heart. These criteria can, therefore, help to eliminate many spurious or unimportant ‘spins’ or ‘focal discharges’ uncovered in the current state of the art that are not drivers of the sources associated with heart rhythm disorders, and can help to improve treatment where localized therapy has not been successful in the past.

The ability to determine accurate activation information of heart beats in complex disorders has previously been very difficult, such that targeted therapy aimed at the source(s) of these disorders has not been possible. Among the advantages of the present disclosure is the ability to recognize rotational electrical patterns, even amidst the virtually indiscernible sensed activation patterns, such that a determination of the source of the disorder can be determined and treated.

Complex rhythm disorders are directly caused by localized sources, from whence activation may take the form of spiral waves with rotational electrical activity, focal sources in which activation emanates centrifugally or a combination. The complexity of multiple concurrent drivers can cause disorganized activation patterns (sources), which have obscured prior attempts to map these rhythms. In this way, passive activation from colliding or secondary wave fronts may transiently obscure the detection of the source of the disorder, but not terminate its internal driver. In electrophysiological terms, this is similar to pacing ‘entrainment’ transiently altering activation sequences around a driver (e.g., in the Wolff-Parkinson-White syndrome or atrial flutter), with redetection of the driver when entrainment stops. The present disclosure shows that this is also true for detection of drivers of sources associated with complex rhythm disorders.

Accordingly, rotational electrical activity from a spiral wave (rotor, reentrant circuit) may appear to be insignificant, either in the degree or duration of the rotation, or have inconsistent rotation patterns. It has previously been unclear how to separate sources from transient activation of an occasional rotation or single cycle where activation appears to emanate from an origin, inherent in all complex rhythms. This task has been more difficult since sources for complex rhythms are not points, but occupy limited spatial areas within which the driver may move (termed “meander” or “precession”)—akin to the movement of a spinning object in a gravity well.

The present disclosure provides a system and method for defining or identifying persistent rotational drivers or focal drivers within localized sources associated with complex rhythm disorders. Rotational drivers can be defined or identified by showing that activation sequences trace successive angles, or show successive angular sectors over time, or using phase mapping, vector analysis and other methods. Focal drivers can be identified by vectors, coherence, correlation, phase and other analytic methods to identify centrifugal activation from an origin. Additionally, the system and method of the present disclosure provide qualitative and/or quantitative indicators to indicate the strength, consistency, and duration of identified phase singularities.

Another advantage is that the present disclosure provides a system and method that can be carried out rapidly while a sensing device, e.g., a catheter having sensors thereon, is used in or near the patient and can be followed by treatment of cardiac tissue to ameliorate the disorder and in many cases cure the disorder. Treatment may thus occur immediately upon computing the rotational electrical pattern infor-

mation of the driver of the source, since it will indicate the location(s) of the cause or source of the disorder.

FIG. 1 illustrates an example system for identifying the driver (an area of the heart) associated with the source of a heart rhythm disorder **100**. The example system **100** is configured to identify a driver, in the form of persistent rotational or centrifugal patterns, associated with sensed cardiac electrical activity of a patient’s heart **120** in connection with determining the source of a heart rhythm disorder. The heart **120** includes a right atrium **122**, left atrium **124**, right ventricle **126** and left ventricle **128**.

The example system **100** includes a catheter **102**, signal processing device **114**, computing device **116** and analysis database **118**. The catheter **102** is configured to detect cardiac electrical information in the heart and to transmit the detected cardiac electrical information to the signal processing device **114**, either via a wireless or wired connection. The catheter includes an array of probes/sensors **104**, which can be inserted into the heart through the patient’s blood vessels. Sensors **104** may provide unipolar and/or bipolar signals.

In some embodiments or aspects, one or more of the sensors **104** are not inserted into the patient’s heart **120**. For example, some sensors may detect cardiac electrical information via the patient’s surface (e.g., electrocardiogram) or remotely without contact with the patient (e.g., magnetocardiogram or methods to identify electrical information via the inverse solution). As another example, some sensors may also derive cardiac electrical information from cardiac motion of a non-electrical sensing device (e.g., echocardiogram). In various embodiments or aspects, these sensors can be used separately or in different combinations, and further these separate or different combinations can also be used in combination with sensors inserted into the patient’s heart **120**.

The sensors **104** are positioned at respective sensor locations adjacent to or contacting tissue in the heart **120** or near the heart **120**. The sensors **104** can detect cardiac electrical activity at the sensor locations and can generate corresponding sensing signals which are output to the signal processing device **114**. The sensors **104** may further be configured to deliver energy to ablate the heart **120** at the sensor locations, particularly when the sensor location is adjacent to or contacting heart tissue.

The signal processing device **114** is configured to process (e.g., clarify and amplify) the sensing signals generated by the sensors **104** and to output corresponding cardiac signals. The computing device **116** receives (which refers to receiving or accessing) the cardiac signals and processes them in accordance with methods disclosed herein to identify rotational electrical activity (clockwise or counterclockwise) or centrifugal activity (indicating a focal driver) from the cardiac signals. Additionally, the computing device **116** identifies indices of driver activity that are persistent.

The computing device **116** displays an activation propagation map (APM) video **150** that combines and spatially lays out data from a plurality of monophasic action potential (MAP) voltage representations of the cardiac signals. The APM video **150** includes a sequence of APM frames that are associated with a series of time increments over a time interval. Arrow **152** indicates rotational movement of displayed information. Each element in the MAP representation is associated with a respective sensor **104** of the array of sensors. A MAP representation includes voltage (or charge) versus time and other indexes. For rotational drivers, detection may also use information on rotational angles, solid angles, angular velocity, and tangential velocity at the cir-

cumference of rotation and phase information. For focal sources, information may also include centrifugal indexes (such as velocity and acceleration), and centripetal indexes (such as velocity and acceleration). Centripetal indexes typically indicate a passive area (not a source), but may indicate a source that is moving away from the sensor. For all sources, quantification includes stigmata of dynamic movement such as Doppler shift, disorganization in the core, and measures of entropy since the driver may move constantly and dynamically within the source region. Information may also include activation onset time information associated with the electrical activity sensed by a sensor **104** of the array of sensors. The MAP representation can be mapped as curves on time and voltage axes, as well as several other representations including polar plots and three-dimensional plots.

As used herein, activation onset time is a time point at which activation commences in a cell or tissue, as opposed to other time points during activation. Activation is a process whereby a cell commences its operation from a quiescent (diastolic) state to an active (electrical) state.

The computing device **116** receives, accesses, or generates the signal representations and APM video **150**. An example of generation of an APM video **150** and a signal representation in the form of a monophasic action potential (MAP) is described in U.S. Pat. No. 8,165,666, which is incorporated herein by reference in its entirety. In particular, FIG. 11 of the '666 patent illustrates an APM video **150** of MAPs. Other signals of value include noise-free unipolar electrograms and processed unipolar electrograms. Similarly, other systems and methods can reconstruct cardiac or biological activation information to include activation times, phase information and onset.

The APM video **150** may be generated by systems and methods that can display process or reconstruct cardiac or biological electrical information over time to generate a dynamic video representation of activation information, electrical activity, rotational activity and/or a core associated with the rotational activity, focal activity and/or the origin from where centrifugal activation emanates.

In one embodiment or aspect, rotational activation is indicated from phase mapping by a phase singularity, in which the dynamic activation information may exhibit rotational motion. The APM video **150** in this case may also display an indicator of a phase singularity, such as a white dot, that may be determined by calculations performed per frame. Each frame displays information based on measurements made at the time of the frame. The degree of confidence in each rotational driver in this embodiment is indicated by the persistence of a phase singularity over time. Singularities detected for only a short amount of time may be displayed in only a few frames so that the visual indication is not visible, is barely visible, and/or quickly disappears. When there is persistence, the frame-by-frame rotational motion may be visible and detectable to a viewer.

FIG. 2 illustrates a phase-time curve **200** generated from voltage-time data (activation-time data) of MAP signals obtained during the heart rhythm disorder, for one preferred embodiment of rotational driver detection via phase mapping. The phase-time data and phase time curve **200** are generated by processing MAP signals, including converting the voltage-time data represented by MAPs into the phase-time data with noise-reduction and further processing of the data. The voltage-time to phase-time data conversions used for generating curve **200** may be performed by multiplying a normalized voltage of sampled data points along the MAP signal (which may be approximated) by 2π . The phase-time

data is plotted on x-y axes corresponding to time and phase, respectively. Voltage-time to phase-time data conversions are understood by a person having skill in the art. The representation used in the present example is a sawtooth approximation.

The approximation may be performed on the MAP signal before the conversion or after the conversion. The phase-time data shown in FIG. 2 approximates the MAP signal (that actually has four distinct phases, as shown in FIG. 3, but approximates a triangle) with a straight line. A portion of a MAP signal extending between a detected activation onset and a detected beginning of repolarization is approximated with a straight line. Similarly, a portion of the MAP signal extending from the beginning of repolarization to a next activation onset time is approximated with a straight line. Either or both approximations may be used.

FIG. 3 shows an example phase-time curve **300** that is also converted from voltage-time data (activation-time data) associated with MAP signals and then converted to phase-time data, as described above. As shown, an approximation is not used to generate the phase-time data represented by phase-time curve **300**.

The computing device **116** generates, accesses, or receives phase-time data, phase-time curves **200**, **300** and/or the APM **150**. The APM **150** spatially arranges MAPs on a display that may be a two-dimensional or three-dimensional display, such as a model shaped as the heart **120**. The spatial arrangement is relative to the physical sensor locations **104** in relation to the heart **120**. Similarly, other systems and methods that can reconstruct cardiac or biological electrical information to provide representations of cardiac electrical activity having activation onset information (activation-time data) may be used to generate the APM video **150**.

FIG. 4 provides an example two-dimensional APM frame **400** of a series of frames (e.g., an APM video **150**) that correspond to sequential, evenly-spaced time increments (e.g., every millisecond (msec) or every 10 msec) in a time interval. The time interval can be two-ten seconds, or a different interval. Each APM frame **400** can be generated by sampling multiple MAP signals at time t of the time interval.

APM frame **400** includes a grid **402** having an electrode reference **404** labeled 1-8 and a spline reference **405** labeled A-H. The electrode reference **404** and spline reference **405** have 64 intersecting elements, also referred to as sensor elements, which correspond to respective sensors **104** of the array of sensors (e.g., 64 sensors). Four example sensor elements **406**, **408**, **410**, **412** correspond to respective intersections on the grid **402** (1-8, A-H), and further correspond to respective sensors **104** of the array of sensors. Specifically, the sensor elements **406**, **408**, **410**, **412** are located on grid **402** at intersecting elements that may be labeled (6, G), (6, H), (5, H), and (5, G), respectively.

Grid **402** is segmented into a plurality of areas, with each area defined or bounded by at least three sensor elements. The areas are configured as polygons (e.g., a triangle, rectangle, or square), and some cases can cover the entire grid **402**. The sensor elements that define each area are positioned at vertices of the area. An example area **414** is a square having vertices at intersecting elements that may be labeled (6, G), (6, H), (5, H), and (5, G). Area **414** is defined by sensor elements **406**, **408**, **410**, **412** that are positioned at the four vertices of a square (G-H, 6-5). In the example shown, the entire grid **402** is covered by contiguous, non-overlapping square areas, with each square area being bounded or defined by four sensor elements. Area **414** corresponds to an area of the heart **120** defined or bounded by the sensors **104**, which correspond to the sensor elements

406, 408, 410, 412. In another embodiment, the areas may overlap. Similarly, an example second area is defined by sensor elements **416, 418, 420, 422**, which correspond to respective sensors **104**.

The sensor elements of the APM frame **400** are assigned a gray-scale level that corresponds to the voltage (or charge) of the MAP signals. The gray-scale levels for elements located between the sensor elements **406, 408, 410, 412** may be determined using interpolation (e.g., based on the representative MAP signals). The '666 patent and U.S. patent application Ser. No. 13/081,411, which are incorporated herein by reference in their entirety, describe systems and methods to generate a series of APM frames.

A series of APM frames **400** may be displayed in a sequence, e.g., as a video stream (APM video **150**). A viewer may be able to see changes in the represented voltage (or charge) depicted over time. This approach may display either a rotational or focal driver. In this example, the change in voltage has a rotational pattern over time, indicating that a phase singularity has been sensed by sensors **104**. Notably, the displayed rotational patterns may not be indicative of a phase singularity that is associated with a cardiac rhythm disorder. Rotational patterns less likely to indicate drivers of heart rhythm disorders are inconsistent, fleeting, and/or non-persistent; they may change rotational direction and/or have an insubstantial degree of rotation. In fact, some of the rotational patterns may not be displayed for a sufficient number of frames to be visible to a viewer, whereas other rotational patterns may be visible, but may then disappear. Despite all of this, the APM video **150** of APM frames **400** can provide useful information to a surgeon, including dynamic changes over time and the rotational patterns on the grid **402**.

In one embodiment or aspect, the present disclosure provides a system and method that sums, for all of the time increments in a time interval, rotational activity associated with each area on the grid **402**. The total sum is indicative of a phase singularity located at that area. Excluded from the sum, however, is rotational activity that occurs in opposite directions at the same area and rotational activity that has an insubstantial degree of rotation (e.g., satisfies criteria in accordance with the disclosed method described below). The sum is recorded by a rotational counter associated with each area of the grid **402**. The rotational counter is modified, e.g., incremented, each time there is rotational activity having a substantial degree of rotation in the associated area. When the time interval is ended, the magnitude of the rotational counter associated with each area of the grid **402** indicates the existence and degree of persistence of phase singularities at each area of the grid **402**.

Turning now to FIGS. **5** and **6**, a method is described for determining whether rotational activity at time t has a substantial degree of rotation that would warrant incrementing the rotational counter. For each time t , a phase sum is calculated for each area on grid **402**. The phase sum is calculated by determining a shortest path between a sequence of the sensor elements (**406, 408, 410, 412**) beginning and ending at a first sensor element of the sequence, calculating a phase difference between the sensor elements in the sequence using a shortest path, and summing the phase differences. The calculated phase sum result may be 0 , 2π , or -2π . Phase sum= 0 indicates insufficient rotational activity for incrementing the rotational counter and indicates that no net rotation is present. Phase sum= 2π or -2π indicates that the rotational counter should be updated, e.g., incremented or decremented, respectively, and indicates that rotation occurs, with the positive or negative sign

indicative of a clockwise or counterclockwise direction of rotation (e.g., depending on a convention selected). The selected convention can be that a positive value is associated with a counterclockwise path, and a negative value is associated with a clockwise path. The selected convention can also be the reversed, i.e., the negative value is associated with the counterclockwise path, and the positive value is associated with the clockwise path.

FIG. **5** illustrates an example method for calculating phase sum at time t for the area **414** defined by sensor elements **406, 408, 410, and 412** in FIG. **4**. A unit circle **502** having radius= 1 is provided. Sensor elements **406, 408, 410, and 412** are disposed on the circumference of the unit circle **502** in accordance with a phase associated with each of the respective sensor elements **406, 408, 410, and 412**. The phase associated with each sensor element **406, 408, 410, and 412** is determined from the phase at time t along the corresponding phase-time curve, e.g., phase-time curves **200** or **300**.

Any sensor element may be selected to be the first sensor element. The sensor elements are then processed in a selected sequence. The sequence may be based on the position of sensor elements **406, 408, 410, and 412** on grid **402**, by proceeding in a counterclockwise or clockwise direction around area **414** among the sensor elements in accordance with their arrangement on grid **402**, beginning with the first selected sensor element and ending with the first sensor element. In this example, sensor elements are ordered as **406, 408, 410, 412**. Sensor element **406** is selected to be the first sensor element.

The shortest path is determined between the first sensor element **406** and the second sensor element **408**. The path **504** in the counterclockwise direction is shorter than an alternative path in the clockwise direction. Therefore, path **504** is determined to be the shortest path between sensor elements **406** and **408**.

The phase difference **512** between the sensor elements **406** and **408** for shortest path **504** is determined. The phase difference **512** is assigned a positive value because the shortest path from sensor element **406** to sensor element **408** is in a counterclockwise direction based on the selected convention.

The shortest path and phase difference are similarly determined for each of the sensor element pairs **408** and **410**, **410** and **412**, and **412** and the first sensor element **406**. The shortest paths, respectively, are **506, 508, and 510**, all in the counterclockwise direction. Thus, the respective phase differences **514, 516, and 518** are all positive. The four phase differences **512-518** are summed to determine the phase sum. Since the entire circumference of the unit circle is traversed in the counterclockwise direction along the shortest paths **504-510**, all of the phase differences are positive. Phase sum= 2π , which indicates the possible presence of a rotational driver.

The example in FIG. **5** illustrates that there is an indication of a rotational driver when a full circle around the unit circle **502** is completed by following the shortest paths between sensor elements **406, 408, 410, 412** disposed on the unit circle **502**, including back to the first sensor element **406**. When the rotation between the sensors **104** is in one direction, the phase differences are all positive or all negative and do not cancel each other out. This results in a phase sum= 2π , which indicates that the rotational activity measured at the corresponding sensors **104** is consistent with a rotational driver of the heart rhythm disorder.

FIG. **6** illustrates another example for calculating phase at time t for another area of the grid **402**. A unit circle **602**

having radius=1 is provided with sensor elements **416**, **418**, **420**, and **422** disposed on the circumference of unit circle **602**.

The shortest path **604** is determined between the first sensor element **416** and the second sensor element **418**. The path in the clockwise direction is shorter than an alternative path in the counterclockwise direction. Therefore, the shortest path is determined to be the shortest path **604**.

The phase difference **612** between the sensor elements **416** and **418** for the shortest path **604** is determined. The phase difference **612** is assigned a negative value because the shortest path **604** from sensor element **416** to sensor element **418** traverses the circumference of the unit circle **602** in a clockwise direction based on the selected convention.

The shortest path and phase difference are similarly determined for each of sensor element pairs **418** and **420**, **420** and **422**, and **422** and the first sensor element **416**. The shortest paths, respectively, are **606**, **608**, and **610**. Shortest path **606** is directed in a clockwise direction. Therefore, phase difference **614** has a negative value. Shortest paths **608** and **610** are in a counterclockwise direction. Therefore, phase differences **616** and **618** have positive values. The phase differences **612** and **614** cancel out the phase differences **616** and **618**, since they are equal in magnitude when summed, but opposite in direction. Thus, the sum of phase differences **612-618** is zero (0), which indicates the absence of a phase singularity at this area.

The example in FIG. 6 illustrates that there is no indication of rotation when a full circle around the unit circle **602** cannot be completed by following the shortest paths between sensor elements **416**, **418**, **420**, **422** disposed on the unit circle **602**, including back to the first sensor element **416**. When the rotation between the sensors **104** is in different directions (clockwise and counterclockwise), then some phase differences are positive and some are negative, cancelling each other out. This results in a phase sum=0, which indicates that the rotational electrical activity measured at the corresponding sensors **104** is insufficient to indicate a rotational driver.

FIGS. 7 and 8 provide example flow diagrams that describe an example method **700** to process activation-time data for a time interval TI in order to detect rotational activation that is sufficiently significant and persistent to indicate the existence of a source of a cardiac rhythm disorder.

Importantly, the flowcharts outline a method and a system to sum indexes of rotational activation (detected for instance, via singularities or angles of rotation) as well as focal drivers (detected, for instance, from centrifugal activation). This is important since both may coexist, and because the principle of centrifugal activation from a source may apply whether the driver associated with the source is focal or rotational. Thus, all analyses included in this specification include either analyses (summation) of indexes of rotational activation, indexes of centrifugal activation (that may be centripetal if the source moves) or a combination over time.

The method further includes generating a visual quantitative display of the persistence of drivers of sources associated with heart rhythm disorders. The heat map indicates locations in grid **402** associated with persistent rotations and/or the degree of the persistence. Heat map displays the areas of grid **402** and assigns each area a visual indication (e.g., color, shade, or intensity) that indicates the magnitude of the rotational counter associated with that area. When the rotational counter associated with an area is incremented or

decremented by 1, the visual indication associated with that area is increased or decreased, respectively, by one unit to show the change in the rotational counter.

A unit of a visual indication may be for example, a spectral unit, e.g., along the rainbow spectrum, such as wherein red is at the high end and violet is at the low end, a shade of gray unit; or an intensity unit. These units can be dimensionless, can indicate a ratio relative to a baseline uniform (non-rotational) propagation field, or can have other dimensions. This will vary with the specific heart rhythm disorder and signal source under consideration, but may include degrees (radians) or persistent rotation, a ratio (%) of persistence across a number of cycles, a correlation value (dimensionless) and other dimensions.

The heat map may include a single map or a video including a series of maps. The heat map may be displayed independently or overlaid (e.g., superimposed) over another map, such as an APM frame or a structural map of a corresponding biological structure, e.g., the heart **120**. When the heat map is overlaid over an APM frame, such as being overlaid over an APM video **150**, they are synchronized to display information relating to the same time increment. Additionally, they are spatially consistent with one another in reference to the biological structure (e.g., heart **120**).

At step **702**, activation-time data is accessed or received. The activation-time data may be accessed in real time during a procedure in which sensors **104** generate sensing data, or after a procedure is completed. The activation-time data may be accessed from a computing device **116** or a remote device, such as via a wired or wireless communication. Moreover, in some embodiments or aspects, the activation-time data thus accessed or received can be converted to phase-time data in accordance with description in reference to FIGS. 2 and 3 hereinabove.

At initialization step **704**, a time counter, t , is initialized by setting $t=0$. Also, the rotational counter associated with each area of grid **402** is initialized by setting each rotational counter=0. Additionally, the heat map is initialized by setting the visual indication of each area of grid **402** to a neutral visual indication that indicates rotational counter=0 for that area.

At step **706**, an outer loop **708** commences to iteratively process all time increments within time interval TI. Step **706** increments t by a predetermined time increment which, in the current example, is one (1) msec. At step **710**, an inner loop **712** commences to iteratively process each area included in grid **402** (shown in FIG. 4). Accordingly, loops **708** and **712** process all areas of grid **402** for each incremental time t .

At step **710**, a next unprocessed area of grid **402** is selected. For the first pass through the inner loop **712**, a first area is selected. For example, the first area may be selected to be the square area bounded by sensor elements **104** located in the upper left hand corner of grid **402** at grid intersections (8, D), (8, E), (7, E), and (7, D). In some embodiments or aspects, the activation-time data can be converted to phase-time data for the selected area in accordance with description in reference to FIGS. 2 and 3 hereinabove.

The second selected area may also be adjacent to the previously selected area and so on. Accordingly, in the example shown, inner loop **712** is processed forty-nine (49) times until each of the forty-nine (49) areas provided in grid **402** is processed for the current time t . The order of processing the areas may be predefined, but is not limited to any particular order.

As an example, area **414** illustrated in FIG. 4 is selected for processing. The selected area **414** is processed at step **800** to calculate an index of driver activity for the selected area **414**. Accordingly, the grid intersections for sensor elements **406-412** that define the selected area **414** are provided as input to step **800**. The index of driver activity for the selected area **414** is determined at step **800**. For example, the index of driver activity is calculated using the analysis of FIGS. 5 and 6 in accordance with phase-time data converted in accordance with FIGS. 2 and 3. Step **800** outputs the index of driver activity for the selected area **414**, after which control passes to determination step **714**. Step **800** is described below in greater detail with respect to FIG. 8.

At step **714**, a determination is made whether driver activity is over an entire cycle. If the entire cycle is driven by the driver, then control passes to step **716**. If the entire cycle is not driven by the driver, then control passes to step **720**.

At step **716**, a rotational counter associated with the currently selected area is incremented by a count of one. At step **718**, the heat map is updated by increasing the visual indication associated with the selected area by one unit. Then, control passes to step **724**, the end of inner-loop **712**.

At step **720**, the rotational counter is decremented by a count of one. At step **722**, the heat map is updated by decreasing the visual indication associated with the selected area by one unit. Then, control passes to step **724**, the end of inner-loop **712**.

At step **724**, a determination is made whether all areas were processed for time t . If not, execution passes to step **710**, and another pass of inner-loop **712** is processed for the next area until all of the areas of grid **402** have been processed. If the determination at step **724** is that all areas have been processed for time t , then execution proceeds to step **726**, the end of outer-loop **708**, to determine whether all frames for interval TI were processed (e.g., $t \geq TI$).

If the determination at step **726** is that $t < TI$, meaning that there are more time frames (increments) to process for interval TI , then control returns to step **706** and a next pass of outer-loop **708** is performed for the next time increment. If the determination at step **726** is that $t = TI$, meaning that all of the frames in interval TI have been processed, then outer-loop **708** is terminated, and control passes to step **728**, at which the method **700** ends.

In operation, during each iteration of outer-loop **708** at time t , all areas are processed and the rotational counter and the visual indication of the heat map associated with each area are updated and summed. Thus, with each subsequent iteration of outer-loop **708**, the rotational counter associated with each area is updated by incrementing or decrementing the rotational counter, depending on the rotational direction. When a possible rotational driver having the same rotational direction is detected in an area in many iterations of outer-loop **708**, the rotational counter associated with that area is successively incremented (or decremented, depending upon polarity) and achieves a relatively high magnitude in the positive or negative direction, indicating the presence of persistent rotational activation in a counterclockwise or clockwise direction at the area.

On the other hand, when opposite rotational directions occur during different iterations of outer-loop **708**, the rotational counter is incremented and then decremented (or vice versa), cancelling out an increase in magnitude (herein referring to the rotational counter absolute value), indicating that a persistent rotational driver does not exist at the area. Accordingly, the magnitude of the rotational counter asso-

ciated with each area is indicative of the persistence of rotation in a consistent rotational direction.

In some embodiments or aspects, the heat map may include only the final frame, and/or the final magnitude of the rotational counter for each area may be reported. The magnitude of each rotational counter indicates whether rotation occurs in the associated area and its degree of persistence. The final magnitude of the rotational counter associated with the respective area may be compared to a predetermined threshold. If the rotational counter exceeds the threshold, a determination may be made that persistent rotation occurs in the associated area. While the final magnitude of the rotational counter provides static quantitative information, the final heat map frame provides static qualitative visual information about the existence and persistence of rotational patterns.

In other embodiments or aspects in which the method **700** is performed, when the phase-time data for the entire time interval and/or all of the areas is available before beginning execution of step **704**, some or all of the execution steps in the example method **700** may be performed in a different order, serially, in parallel, or a combination thereof, as opposed to iteratively. Steps associated with different frames and/or different areas may be performed in a different order, serially, in parallel, or a combination thereof. The method **700** ends at step **728**.

With reference to FIG. 8, an example method is shown for executing step **800** in FIG. 7. The method processes an area and determines an index of driver activity for the area. At input step **801** the identification of the area selected at step **710** in FIG. 7 is provided as input. The input includes identification of the sensor elements that define the selected area. In the present example, the selected area is area **414** which is defined by the sensor elements **406-412**.

At step **802**, the index of driver activity is initialized to 0. At step **804**, a loop **806** commences for iteratively selecting, in a sequence, sensor elements **406-412** that define the area **414**, for example. In the current example, sensor element **406** is selected for the first pass through loop **806**. Sensor elements **408**, **410**, and **412** are selected sequentially for subsequent respective passes through loop **806**. The example sequence describes a counterclockwise path around area **414**. Other sequences may be selected.

At step **808**, the index of driver activity is determined based on last and next vertexes of a selected area, e.g., between a selected sensor element and the next sensor element in the sequence, moving from the selected sensor element to the next sensor element in a selected direction (e.g., clockwise or counterclockwise). It is noted that the same selected direction is used for all iterations of loop **806**. In the present example, during the first pass through loop **806**, the index of driver activity between sensor elements **406** and **408** is determined. During the second, third and fourth passes, respectively, the index of driver activity between sensor elements is determined. At step **810**, a determination is made as to whether an arc of rotation continues in the same direction. If no, step **812** is executed to adjust the index of driver activity, e.g., subtracting a value from the index of the driver activity. If yes, step **814** is executed to adjust the index of driver activity, e.g., adding a value to the index of the driver activity.

At step **818**, end of loop **806**, a determination is made whether all vertexes (e.g., sensor elements **406-412**) were processed for the selected area **414**. If not, control returns to step **804** to select the next sensor element in the sequence and to execute loop **806** with the newly selected sensor element. After the final iteration of loop **806**, at step **818** a

determination is made whether all of the sensor elements have been selected and processed. If so, the index of driver activity is output at step 820 and control passes to step 714 of FIG. 7.

Now with reference to FIG. 7, the heat map generated by the computing device 116 is overlaid on an APM frame. The heat map may include a series of frames that correspond to the time increments associated with each iteration of outer-loop 708. The heat map uses a visual indication, such as color, intensity, or shades of gray to indicate the magnitude of the rotational counter associated with each area of grid 402. The higher the magnitude of the rotational counter, the stronger the persistence of detected rotational activation areas.

Different colors or shades of gray may be assigned to various rotational counter magnitudes. The colors and shades of the heat map may be translucent so that when overlaid over another map, graphic, text, or the like, the underlying information may be visible. In a multicolor configuration, for example, warm colors may be assigned to the higher rotational counter magnitudes, and cool colors may be assigned to the lower rotational counter magnitudes (e.g., based on the rainbow spectrum), with red indicating the highest magnitude and purple representing the lowest. In a gray-scale configuration, for example, light shades may be assigned to the higher magnitudes and dark shades may be assigned to the lower magnitudes, with white indicating the highest magnitude and black representing the lowest magnitude.

In the current example, a single color is used, such as red, wherein the intensity of the color increases with the magnitude of the rotational counter. When the rotational counter=0 the color is not displayed.

As iterations of outer-loop 708 are processed and the rotational counter is updated, the heat map is updated, frame by frame. Thus, each frame of heat map represents a summation of the previous frames. Throughout the summation, an increase of magnitude of the rotational counter indicates existence of and persistence of a detected rotational pattern. When step 728 is reached, a final frame of the heat map has been generated and the heat map is complete. The final frame shows the summation of all the previous frames and graphically shows persistent rotations, their location on the grid 402, and the degree of their persistence.

The displayed heat map indicates the location of a persistent rotational pattern (driver) to a viewer, e.g., a surgeon. The surgeon may use that information to identify a source associated with a cardiac rhythm disorder. Accordingly, the surgeon may treat cardiac tissue at the source, and/or the rotational pattern (driver) that drives the source, or within a possible margin of tissue to suppress or eliminate the cardiac rhythm disorder.

The series of frames of the heat map may be stored and replayed. Since the information is summed for all areas of grid 402 with each iteration of outer-loop 708, as the series of frames of the heat map video is replayed, the visual indications of persistence are dynamic, with persistent rotation shown increasing in intensity, and fleeting rotation or noise either not visible, or visible for a short duration and then disappearing or fading.

The grid 402 may be normalized with respect to a preference value. The preference value may be used to set a most significant value to one (1), with the others assuming a range between zero (0) and one (1). Alternatively, the grid 402 may be normalized with respect to the time analyzed, reflecting a percentage of time during which detected phase singularities are present.

FIG. 9 shows a frame 900 that includes a heat map frame 902 overlaid over an APM frame 903. APM frame 903 may be a single stand-alone frame or may belong to a series of APM frames, e.g., a video 150. When the heat map 902 video is overlaid over an APM video, the maps can be synchronized so that the frames 902 and 903 correspond to the same time increment. Alternatively, they may be unsynchronized.

The example APM 903 includes an area of electrical activity 906 that moves about a central point, as seen when playing back previous frames. Based on information gathered in a single frame, the central point has been identified as a region having repeating activation indicated by a white dot 904. The heat map 902 includes an area 908 that includes areas 910, 912, 914 of varying intensity, listed here from least to most intense. The area 908 indicates that the rotational counter associated with that portion of heat map 902 has been incremented, with the intensity of the red area 908 increasing in areas 912 and 914 in accordance with the magnitude of the rotational counter. The most intense area 914 corresponds to the highest calculated magnitude of the rotational counter. The highest calculated magnitude of the rotational counter and the most intense area 914 may indicate the center (driver) of the electrical activity 906 and be indicative of the source of a cardiac rhythm disorder. Here, the most intense area 914 is located near white dot 904 of the APM 903. Accordingly, the white dot 904 of the APM 903 is consistent with the intense red area 914 of the heat map 902.

An example area 918 is shown on heat map 902, with its boundaries indicated by dotted lines. The area 918 may include smaller elements 920. The visual indication associated with the area 918 may vary within the area 918, with different elements 920 appearing to have a different visual indication. Methods and calculations, such as interpolation, may be used to vary the visual indication of different elements 920 within area 918. Additionally, the appearance of the visual indication of the two elements 920 having the same visual indication may differ due to the underlying image, e.g., the APM 903.

The heat map 902 provides a summation of information that builds over the course of the video to display persistent patterns, and filters out events that do not have a significant amount of associated rotation. The combination of information provides the viewer with a combination of robust information, dynamic information and locational information.

Additionally or alternatively, the heat map 902 may be overlaid or superimposed on an image of the sensor locations and/or the anatomy where the sensors 104 are positioned. This combination of images may provide additional locational information relating the location of the persistent phase singularities relative to the location of the sensors 104.

FIG. 10 is a block diagram of an illustrative embodiment of a general computing system 1000. The computing system 1000 can include a set of instructions that can be executed to cause the computing system 1000 to perform any one or more of the methods or computer based functions disclosed herein. The computing system 1000, or any portion thereof, may operate as a standalone device or may be connected, e.g., using a network 1024 or other connection, to other computing systems or peripheral devices.

The computing system 1000 may also be implemented as or incorporated into various devices, such as a personal computer (PC), a tablet PC, a personal digital assistant (PDA), a mobile device, a palmtop computer, a laptop computer, a desktop computer, a communications device, a

control system, a web appliance, or any other machine capable of executing a set of instructions (sequentially or otherwise) that specify actions to be taken by that machine. Further, while a single computing system **1000** is illustrated, the term “system” shall also be taken to include any collection of systems or sub-systems that individually or jointly execute a set, or multiple sets, of instructions to perform one or more computer functions.

As illustrated in FIG. **10**, the computing system **1000** may include a processor **1002**, e.g., a central processing unit (CPU), a graphics-processing unit (GPU), or both. Moreover, the computing system **1000** may include a main memory **1004** and a static memory **1006** that can communicate with each other via a bus **1026**. As shown, the computing system **1000** may further include a video display unit **1010**, such as a liquid crystal display (LCD), an organic light emitting diode (OLED), a flat panel display, a solid state display, or a cathode ray tube (CRT). Additionally, the computing system **1000** may include an input device **1012**, such as a keyboard, and a cursor control device **1014**, such as a mouse. The computing system **1000** can also include a disk drive unit **1016**, a signal generation device **1022**, such as a speaker or remote control, and a network interface device **1008**.

In a particular embodiment or aspect, as depicted in FIG. **10**, the disk drive unit **1016** may include a machine-readable or computer-readable medium **1018** in which one or more sets of instructions **1020**, e.g., software, can be embedded, encoded or stored. Further, the instructions **1020** may embody one or more of the methods or logic as described herein. In a particular embodiment or aspect, the instructions **1020** may reside completely, or at least partially, within the main memory **1004**, the static memory **1006**, and/or within the processor **1002** during execution by the computing system **1000**. The main memory **1004** and the processor **1002** also may include computer-readable media.

In an alternative embodiment or aspect, dedicated hardware implementations, such as application specific integrated circuits, programmable logic arrays and other hardware devices, can be constructed to implement one or more of the methods described herein. Applications that may include the apparatus and systems of various embodiments or aspects can broadly include a variety of electronic and computing systems. One or more embodiments or aspects described herein may implement functions using two or more specific interconnected hardware modules or devices with related control and data signals that can be communicated between and through the modules, or as portions of an application-specific integrated circuit. Accordingly, the present system encompasses software, firmware, and hardware implementations.

In accordance with various embodiments or aspects, the methods described herein may be implemented by software programs tangibly embodied in a processor-readable medium and may be executed by a processor. Further, in an exemplary, non-limited embodiment or aspect, implementations can include distributed processing, component/object distributed processing, and parallel processing. Alternatively, virtual computing system processing can be constructed to implement one or more of the methods or functionality as described herein.

It is also contemplated that a computer-readable medium includes instructions **1020** or receives and executes instructions **1020** responsive to a propagated signal, so that a device connected to a network **1024** can communicate voice, video or data over the network **1024**. Further, the instructions **1020**

may be transmitted or received over the network **1024** via the network interface device **1008**.

While the computer-readable medium is shown to be a single medium, the term “computer-readable medium” includes a single medium or multiple media, such as a centralized or distributed database, and/or associated caches and servers that store one or more sets of instructions. The term “computer-readable medium” shall also include any tangible medium that is capable of storing or encoding a set of instructions for execution by a processor or that cause a computing system to perform any one or more of the methods or operations disclosed herein.

In a particular non-limiting, example embodiment or aspect, the computer-readable medium can include a solid-state memory, such as a memory card or other package, which houses one or more non-volatile read-only memories. Further, the computer-readable medium can be a random access memory or other volatile re-writable memory. Additionally, the computer-readable medium can include a magneto-optical or optical medium, such as a disk or tapes or other storage device to capture and store carrier wave signals, such as a signal communicated over a transmission medium. A digital file attachment to an e-mail or other self-contained information archive or set of archives may be considered a distribution medium that is equivalent to a tangible storage medium. Accordingly, any one or more of a computer-readable medium or a distribution medium and other equivalents and successor media, in which data or instructions may be stored, are included herein.

In accordance with various embodiments or aspects, the methods described herein may be implemented as one or more software programs running on a computer processor. Dedicated hardware implementations including, but not limited to, application specific integrated circuits, programmable logic arrays, and other hardware devices can likewise be constructed to implement the methods described herein. Furthermore, alternative software implementations including, but not limited to, distributed processing or component/object distributed processing, parallel processing, or virtual machine processing can also be constructed to implement the methods described herein.

It should also be noted that software that implements the disclosed methods may optionally be stored on a tangible storage medium, such as a magnetic medium, such as a disk or tape; a magneto-optical or optical medium, such as a disk; or a solid state medium, such as a memory card or other package that houses one or more read-only (non-volatile) memories, random access memories, or other re-writable (volatile) memories. A stored digital file attachment to e-mail or other self-contained information archive or set of archives is considered a distribution medium equivalent to a tangible storage medium. Accordingly, a tangible storage medium or distribution medium as listed herein, and other equivalents and successor media, in which the software implementations herein may be stored, are included herein.

Thus, a system and method to define a rational source associated with a biological rhythm disorder, such a heart rhythm disorder, has been described herein. Although specific example embodiments or aspects have been described, it will be evident that various modifications and changes may be made to these embodiments or aspects without departing from the broader scope of the invention. Accordingly, the specification and drawings are to be regarded in an illustrative rather than a restrictive sense. The accompanying drawings that form a part hereof, show by way of illustration, and not of limitation, specific embodiments or aspects in which the subject matter may be practiced. The embodi-

ments or aspects illustrated are described in sufficient detail to enable those skilled in the art to practice the teachings disclosed herein. Other embodiments or aspects may be utilized and derived therefrom, such that structural and logical substitutions and changes may be made without departing from the scope of this disclosure. This Detailed Description, therefore, is not to be taken in a limiting sense, and the scope of various embodiments or aspects is defined only by the appended claims, along with the full range of equivalents to which such claims are entitled.

Such embodiments or aspects of the inventive subject matter may be referred to herein, individually and/or collectively, by the term "invention" merely for convenience and without intending to voluntarily limit the scope of this application to any single invention or inventive concept if more than one is in fact disclosed. Thus, although specific embodiments or aspects have been illustrated and described herein, it should be appreciated that any arrangement calculated to achieve the same purpose may be substituted for the specific embodiments or aspects shown. This disclosure is intended to cover any and all adaptations or variations of various embodiments or aspects. Combinations of the above embodiments or aspects, and other embodiments or aspects not specifically described herein, will be apparent to those of skill in the art upon reviewing the above description.

The Abstract is provided to comply with 37 C.F.R. § 1.72(b) and will allow the reader to quickly ascertain the nature and gist of the technical disclosure. It is submitted with the understanding that it will not be used to interpret or limit the scope or meaning of the claims.

In the foregoing description of the embodiments or aspects, various features are grouped together in a single embodiment for the purpose of streamlining the disclosure. This method of disclosure is not to be interpreted as reflecting that the claimed embodiments or aspects have more features than are expressly recited in each claim. Rather, as the following claims reflect, inventive subject matter lies in less than all features of a single disclosed embodiment or aspect. Thus the following claims are hereby incorporated into the Detailed Description, with each claim standing on its own as a separate example embodiment or aspect. It is contemplated that various embodiments or aspects described herein can be combined or grouped in different combinations that are not expressly noted in the Detailed Description. Moreover, it is further contemplated that claims covering such different combinations can similarly stand on their own as separate example embodiments or aspects, which can be incorporated into the Detailed Description.

The invention claimed is:

1. A method of identifying an area of a human heart, the area associated with control of a source of a cardiac rhythm disorder of the human heart, the method comprising:

processing a plurality of cardiac signals associated with sensors arranged spatially in relation to the area of the heart to determine at least one sequence of activation in relation to the sensors over a time interval, the area comprising a first region and a second region associated with the source;

determining a rotational direction of the at least one sequence of activation; and

identifying the first region as associated with controlling the second region when the at least one sequence of activation continues to rotate in the rotational direction with a substantial degree of rotation over the time interval as indicated by a rotational counter incremented in excess of a threshold.

2. The method of claim 1, wherein the sensors define vertices of the area of the heart.

3. The method of claim 2, wherein the area comprises a plurality of areas of the heart defined by the vertices, the plurality of areas associated with controlling the source of the cardiac rhythm disorder.

4. The method of claim 1, wherein the method further comprises generating an indicator associated with the area of the heart as controlling the source.

5. The method of claim 4, wherein the method further comprises corresponding the indicator to the sensors arranged spatially in relation to the area of the heart.

6. The method of claim 5, wherein corresponding the indicator to the sensors arranged spatially in relation to the area of the heart comprises overlaying the indicator over a representation of the plurality of cardiac signals.

7. The method of claim 1, wherein determining the rotational direction of the at least one sequence of activation further comprises:

determining arcs of rotation of the at least one sequence in relation to the sensors over the time interval; and determining rotational directions of the arcs of rotation.

8. The method of claim 7, wherein identifying the area of the heart as associated with controlling the source further comprises determining that the rotational directions of the arcs of rotation continue in the rotational direction in excess of the threshold.

9. The method of claim 7, wherein determining a rotational direction of an arc of rotation comprises:

selecting a first cardiac signal and a second cardiac signal from the plurality of cardiac signals; determining indices of rotational activity among the first cardiac signal and the second cardiac signal at a plurality of time points during the time interval; and combining the indices of rotational activity to define the rotational direction of the arc of rotation.

10. The method of claim 9, wherein determining an index of rotational activity comprises:

calculating a phase difference among the first cardiac signal and the second cardiac signal at a time point of the time interval; and

determining whether the phase difference is less than or equal to a first phase threshold, or whether the phase difference is greater than a second phase threshold;

incrementing the phase difference by a phase value when the phase difference is less than or equal to the first phase threshold; and

decrementing the phase difference by the phase value when the phase difference is greater than the second phase threshold.

11. The method of claim 10, wherein combining the indices of rotational activity comprises summing calculated phase differences, as incremented or decremented, at the plurality of time points of the time interval.

12. The method of claim 1, wherein the method further comprises:

performing processing, determining and identifying over a plurality of time intervals; and

determining persistence of the identified area as controlling the source when the at least one sequence of activation continues to rotate in the rotational direction over the plurality of time intervals.

13. The method of claim 12, wherein the method further comprises generating an indicator associated with the persistence of the identified area as associated with controlling the source.

21

14. The method of claim 13, wherein the method further comprises corresponding the indicator to the sensors arranged spatially in relation to the area of the heart.

15. The method of claim 14, wherein corresponding the indicator to the sensors arranged spatially in relation to the area of the heart comprises overlaying the indicator over representations of the plurality of cardiac signals associated with the plurality of time intervals.

16. A system to identify an area of a human heart, the area associated with control of a source of a cardiac rhythm disorder of the human heart, the system comprising:

- a processing device; and
- a memory device to store a plurality of instructions that, when executed by the processing device, cause the processing device to perform operations comprising:
 - processing a plurality of cardiac signals associated with sensors arranged spatially in relation to the area of the heart to determine at least one sequence of activation in relation to the sensors over a time interval, the area comprising a first region and a second region associated with the source;
 - determining a rotational direction of the at least one sequence of activation; and
 - identifying the first region as associated with controlling the second region when the at least one sequence of activation continues to rotate in the rotational direction with a substantial degree of rotation over the time interval as indicated by a rotational counter incremented in excess of a threshold.

17. The system of claim 16, wherein the sensors define vertices of the area of the heart.

18. The system of claim 17, wherein the area comprises a plurality of areas of the heart defined by the vertices, the plurality of areas associated with controlling the source of the cardiac rhythm disorder.

19. The system of claim 16, wherein the operations further comprise generating an indicator associated with the area of the heart as controlling the source.

20. The system of claim 19, wherein the operations further comprise corresponding the indicator to the sensors arranged spatially in relation to the area of the heart.

21. The system of claim 20, wherein the operations further comprise overlaying the indicator over a representation of the plurality of cardiac signals.

22. The system of claim 16, wherein the operations to determine the rotational direction of the at least one sequence of activation comprise:

- determining arcs of rotation of the at least one sequence in relation to the sensors over the time interval; and
- determining rotational directions of the arcs of rotation.

23. The system of claim 22, wherein the operations to identify the area of the heart as associated with controlling the source comprise determining that the rotational direc-

22

tions of the arcs of rotation continue in the rotational direction in excess of the threshold.

24. The system of claim 23, wherein the operations to determine a rotational direction of an arc of rotation comprise:

- selecting a first cardiac signal and a second cardiac signal from the plurality of cardiac signals;
- determining indices of rotational activity among the first cardiac signal and the second cardiac signal at a plurality of time points during the time interval; and
- combining the indices of rotational activity to define the rotational direction of the arc of rotation.

25. The system of claim 24, wherein the operations to determine an index of rotational activity comprise:

- calculating a phase difference among the first cardiac signal and the second cardiac signal at a time point of the time interval; and
- determining whether the phase difference is less than or equal to a first phase threshold, or whether the phase difference is greater than a second phase threshold;
- incrementing the phase difference by a phase value when the phase difference is less than or equal to the first phase threshold; and
- decrementing the phase difference by the phase value when the phase difference is greater than the second phase threshold.

26. The system of claim 24, wherein the operation to combine the indices of rotational activity comprise summing calculated phase differences, as incremented or decremented, at the plurality of time points of the time interval.

27. The system of claim 16, wherein the operations further comprise:

- performing processing, determining and identifying over a plurality of time intervals; and
- determining persistence of the identified area as controlling the source when the at least one sequence of activation continues to rotate in the rotational direction over the plurality of time intervals.

28. The system of claim 27, wherein the operations further comprise generating an indicator associated with the persistence of the identified area as controlling the source.

29. The system of claim 28, wherein the operations further comprise corresponding the indicator to the sensors arranged spatially in relation to the area of the heart.

30. The system of claim 29, wherein the operations to correspond the indicator to the sensors arranged spatially in relation to the area of the heart comprise overlaying the indicator over representations of the plurality of cardiac signals associated with the plurality of time intervals.

* * * * *

专利名称(译)	识别与生物节律紊乱相关的来源的系统和方法		
公开(公告)号	US10098560	公开(公告)日	2018-10-16
申请号	US14/869687	申请日	2015-09-29
[标]申请(专利权)人(译)	加利福尼亚大学董事会 托佩拉公司		
申请(专利权)人(译)	加利福尼亚大学董事会 TOPERA, INC		
当前申请(专利权)人(译)	加利福尼亚大学董事会 TOPERA INC. 美洲的美国为代表的退伍军人事务署		
[标]发明人	NARAYAN SANJIV BRIGGS CAREY ROBERT SEHRA RUCHIR		
发明人	NARAYAN, SANJIV BRIGGS, CAREY ROBERT SEHRA, RUCHIR		
IPC分类号	A61B5/024 A61B5/042 A61B5/00 A61B5/046		
CPC分类号	A61B5/0422 A61B5/046 A61B5/0002 A61B5/0006 A61B5/02405 A61B5/04012 A61B18/12 A61B2562/04 A61B5/02444 A61B5/044 A61B5/0452 A61B5/6852 A61B2560/0475		
优先权	PCT/US2014/029645 2014-03-14 WO		
其他公开文献	US20160015283A1		
外部链接	Espacenet		

摘要(译)

提供了一种系统和方法，以定义与人类心脏的心律紊乱相关的源的驱动器。处理与相对于心脏区域在空间上布置的传感器相关联的多个心脏信号，以在一段时间间隔内确定相对于传感器的旋转弧序列。确定序列中的旋转弧的旋转方向。当序列中的旋转弧的旋转方向在超过阈值的相同旋转方向上继续时，心脏区域被识别为控制源。

