



US009668655B2

(12) **United States Patent**
Fojtik

(10) **Patent No.:** **US 9,668,655 B2**
(45) **Date of Patent:** **Jun. 6, 2017**

- (54) **LARGE SURFACE AREA TEMPERATURE SENSING**
- (71) Applicant: **CIRCA Scientific, LLC**, Englewood, CO (US)
- (72) Inventor: **Shawn P. Fojtik**, Park City, UT (US)
- (73) Assignee: **CIRCA Scientific, LLC**, Englewood, CO (US)
- (*) Notice: Subject to any disclaimer, the term of this patent is extended or adjusted under 35 U.S.C. 154(b) by 0 days.

- (21) Appl. No.: **14/567,924**
- (22) Filed: **Dec. 11, 2014**

(65) **Prior Publication Data**
US 2015/0094570 A1 Apr. 2, 2015

Related U.S. Application Data
(62) Division of application No. 12/406,771, filed on Mar. 18, 2009, now Pat. No. 9,155,476.
(Continued)

(51) **Int. Cl.**
A61B 5/00 (2006.01)
A61B 5/01 (2006.01)
(Continued)

(52) **U.S. Cl.**
CPC *A61B 5/015* (2013.01); *A61B 5/01* (2013.01); *A61B 5/4836* (2013.01); *A61B 5/687* (2013.01);
(Continued)

(58) **Field of Classification Search**
CPC *A61B 5/015*; *A61B 5/01*; *A61B 5/6853*; *A61B 5/6858*; *A61B 2018/00797*;
(Continued)

(56) **References Cited**
U.S. PATENT DOCUMENTS

D237,116 S 10/1975 Ekbladh
D282,965 S 3/1986 Wellenstam
(Continued)

FOREIGN PATENT DOCUMENTS

EP 1 504 725 A1 2/2005
JP HEI 01-107307 7/1989
(Continued)

OTHER PUBLICATIONS

European Patent Office, "Supplementary European Search Report," in European Application No. 09721913.3, mailed May 8, 2013.
(Continued)

Primary Examiner — Max Hindenburg
Assistant Examiner — Jonathan M Foreman
(74) *Attorney, Agent, or Firm* — Durham Jones & Pinegar, P.C., Intellectual Property Law Group

(57) **ABSTRACT**

A temperature probe for monitoring temperatures of a surface of a tissue or organ within the body of a subject includes a section with a substantially two-dimensional arrangement and a plurality of temperature sensors positioned across an area defined by the substantially two-dimensional arrangement. Such an apparatus may be used in conjunction with procedures in which thermal techniques are used to diagnose a disease state or treat diseased tissue. Specifically, a temperature probe may be used to monitor temperatures across an area of a surface of a tissue or organ located close to the treated tissue to prevent subsection of the monitored tissue or organ to potentially damaging temperatures.

18 Claims, 5 Drawing Sheets

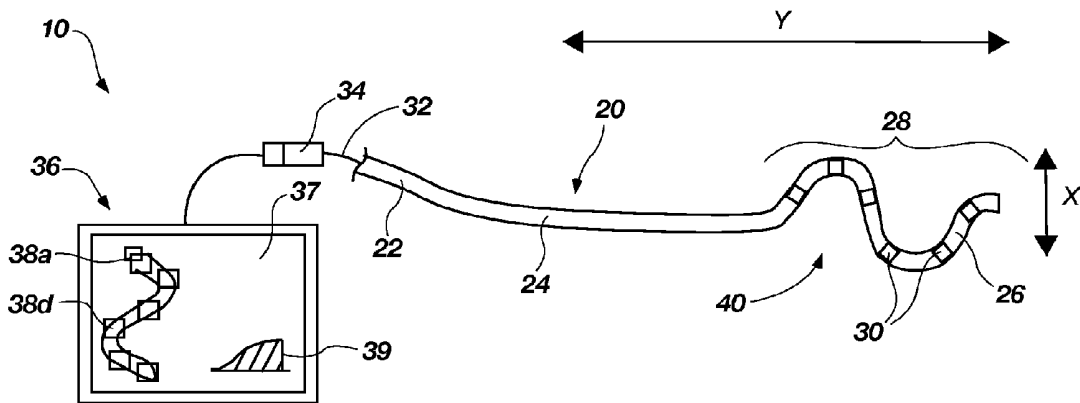

Related U.S. Application Data

(60) Provisional application No. 61/037,624, filed on Mar. 18, 2008.

(51) **Int. Cl.**
A61B 18/00 (2006.01)
A61B 34/20 (2016.01)
A61B 90/00 (2016.01)

(52) **U.S. Cl.**
 CPC *A61B 5/6873* (2013.01); *A61B 5/742* (2013.01); *A61B 18/00* (2013.01); *A61B 34/20* (2016.02); *A61B 5/6853* (2013.01); *A61B 5/6858* (2013.01); *A61B 5/6859* (2013.01); *A61B 2018/00357* (2013.01); *A61B 2018/00404* (2013.01); *A61B 2018/00529* (2013.01); *A61B 2018/00547* (2013.01); *A61B 2018/00577* (2013.01); *A61B 2018/00797* (2013.01); *A61B 2034/2063* (2016.02); *A61B 2090/376* (2016.02); *A61B 2562/0271* (2013.01)

(58) **Field of Classification Search**
 CPC A61B 2562/0271; A61B 5/6859; A61M 25/01; A61M 25/002
 USPC 600/549; 374/100
 See application file for complete search history.

(56) **References Cited**

U.S. PATENT DOCUMENTS

5,170,803 A 12/1992 Hewson et al.
 5,391,155 A 2/1995 Sachse
 5,536,274 A 7/1996 Neuss
 5,673,695 A 10/1997 McGee et al.
 5,800,413 A 9/1998 Swartz et al.
 5,803,902 A 9/1998 Sienkiewicz et al.
 6,015,382 A 1/2000 Zwart et al.
 6,080,118 A 6/2000 Blythe
 6,080,160 A 6/2000 Chen et al.
 6,106,522 A 8/2000 Fleischman et al.
 6,432,041 B1 8/2002 Taniguchi et al.
 6,589,259 B1 7/2003 Solingen
 6,939,313 B2 9/2005 Saadat et al.
 7,140,766 B2 11/2006 Glukhovskiy et al.
 7,293,915 B2 11/2007 Chen
 7,361,180 B2 4/2008 Saadat et al.
 7,621,908 B2 11/2009 Miller
 D611,601 S 3/2010 Tamai et al.
 D624,651 S 9/2010 Leroy et al.
 D624,652 S 9/2010 Carus et al.
 D625,809 S 10/2010 Cuschieri et al.
 D625,812 S 10/2010 Dapri et al.
 D625,813 S 10/2010 Dapri et al.
 D626,226 S 10/2010 Carus et al.
 D626,227 S 10/2010 Leroy et al.
 7,819,817 B2* 10/2010 Rahn 600/549
 2002/0133223 A1 9/2002 Vito et al.
 2003/0013985 A1 1/2003 Saadat
 2004/0073132 A1 4/2004 Maahs et al.
 2004/0176699 A1 9/2004 Walker et al.
 2004/0215296 A1* 10/2004 Ganz A61B 5/0538
 607/99
 2005/0033334 A1 2/2005 Santra et al.
 2005/0240116 A1 10/2005 Saadat et al.
 2006/0009715 A1 1/2006 Khairkhanan et al.
 2006/0085054 A1 4/2006 Zikorus et al.
 2006/0106375 A1 5/2006 Werneth et al.
 2006/0116609 A1 6/2006 Kanuka et al.

2006/0201519 A1 9/2006 Frazier et al.
 2006/0293697 A1 12/2006 Nakao et al.
 2007/0066968 A1 3/2007 Rahn
 2007/0179378 A1* 8/2007 Boese A61B 5/042
 600/407
 2007/0225701 A1 9/2007 O'Sullivan
 2007/0255183 A1 11/2007 Chen
 2008/0033415 A1 2/2008 Rieker et al.
 2008/0077126 A1 3/2008 Rashidi
 2008/0177175 A1 7/2008 Mottola et al.
 2008/0215047 A1 9/2008 Calabro et al.
 2008/0234606 A1 9/2008 Itou
 2008/0243112 A1 10/2008 De Neve
 2008/0306468 A1 12/2008 Tamai et al.
 2009/0030320 A1 1/2009 Ishihara
 2009/0112248 A1 4/2009 Maloney
 2009/0312602 A1 12/2009 Sakamoto et al.
 2010/0002916 A1 1/2010 Yamaguchi
 2010/0030098 A1 2/2010 Fojtik
 2010/0210944 A1 8/2010 Kondo
 2010/0312223 A1 12/2010 Kozak et al.
 2012/0010524 A1 1/2012 Fojtik et al.

FOREIGN PATENT DOCUMENTS

JP HEI 03-056048 A2 8/1991
 JP 2002-541905 A 12/2002
 JP 2005-095602 A 4/2005
 JP 2007-537784 12/2007
 WO 00/62699 A2 10/2000
 WO 02/43789 A2 6/2002
 WO 2005/117755 A2 12/2005
 WO 2006/055286 A2 5/2006
 WO 2007/001981 A2 1/2007
 WO 2009/117523 A2 9/2009
 WO 2012/151584 A1 11/2012

OTHER PUBLICATIONS

File:Sine wave amplitude.svg, May 12, 2008, [online], [retrieved on Mar. 24, 2011]. Retrieved from Internet, <URL: <http://www.wikipedia.org>>.
 File:Waveforms.svg, Oct. 23, 2006, [online], [retrieved on Mar. 24, 2011]. Retrieved from Internet, <URL: <http://www.wikipedia.org>>.
 Korean Intellectual Property Office as International Searching Authority, "International Search Report and Written Opinion," mailed Nov. 2, 2009, in international application No. PCT/US2009/037571.
 Merriam-Webster's Collegiate Dictionary 10th ed. Merriam-Webster, Inc. 2001, p. 449.
 Ralph M. Hartwell II, "An Improved Sine to Square Wave Converter for Rife/Bare Systems," May 24, 2001, [online], [retrieved on Mar. 24, 2011]. Retrieved from Internet, <URL: <http://www.w5jgv.com>>.
 Sine wave, Revision as of Nov. 7, 2006, [online], [retrieved on Dec. 14, 2010]. Retrieved from Internet, <URL: <http://www.wikipedia.org>>.
 United States Patent and Trademark Office Acting as the International Searching Authority, "International Search Report and Written Opinion," in international application No. PCT/US2011/036330, mailed Aug. 16, 2011.
 United States Patent and Trademark Office Acting as the International Searching Authority, "International Search Report and Written Opinion," in international application No. PCT/US2012/036814, mailed Aug. 14, 2012.
 Japanese Patent Office, "Final Notification of Reasons for Rejection," mailed Dec. 19, 2014 in Japanese patent application No. 2013-510314.

* cited by examiner

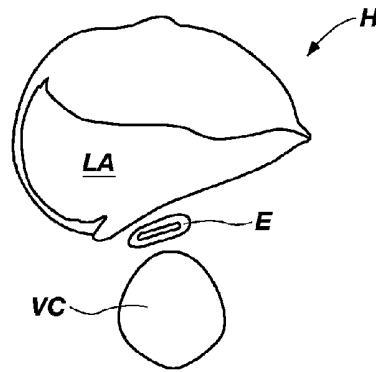

FIG. 1

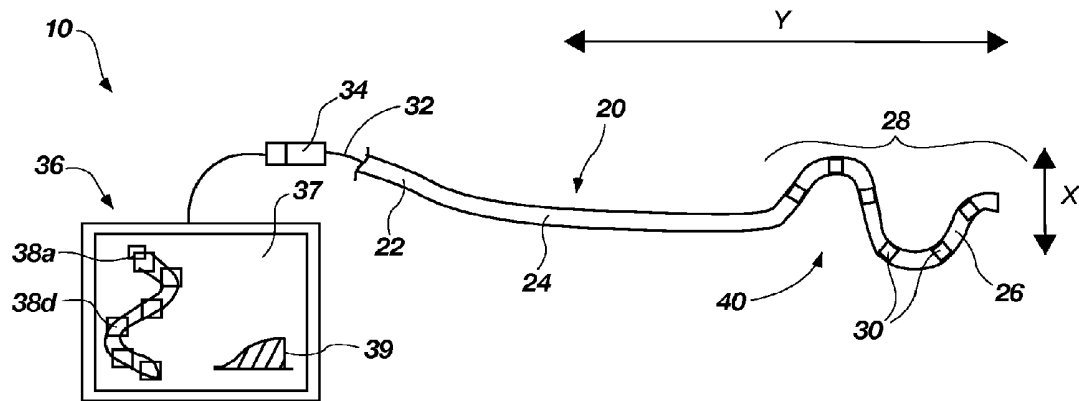

FIG. 2

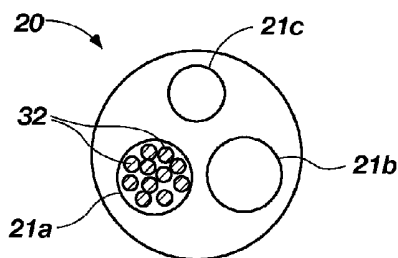

FIG. 2A

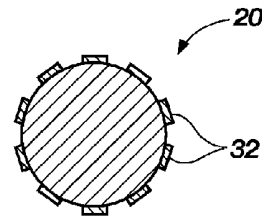

FIG. 2B

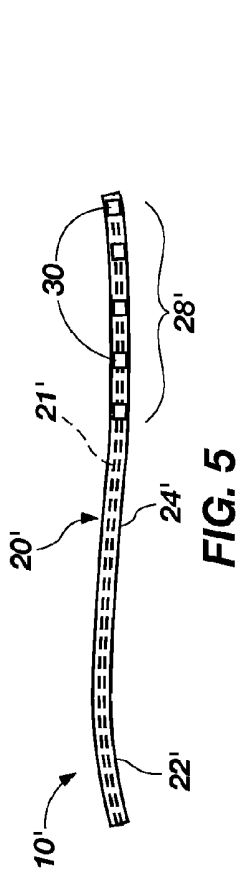

FIG. 5

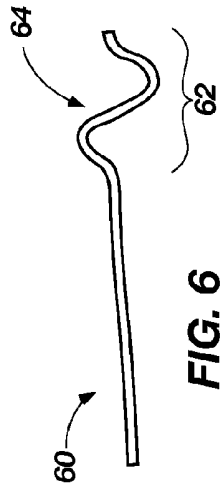

FIG. 6

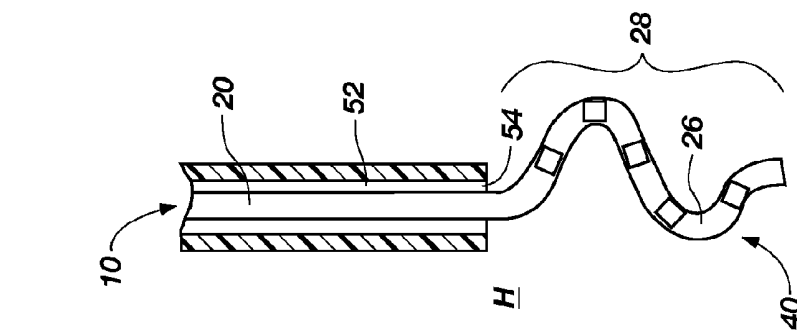

FIG. 7

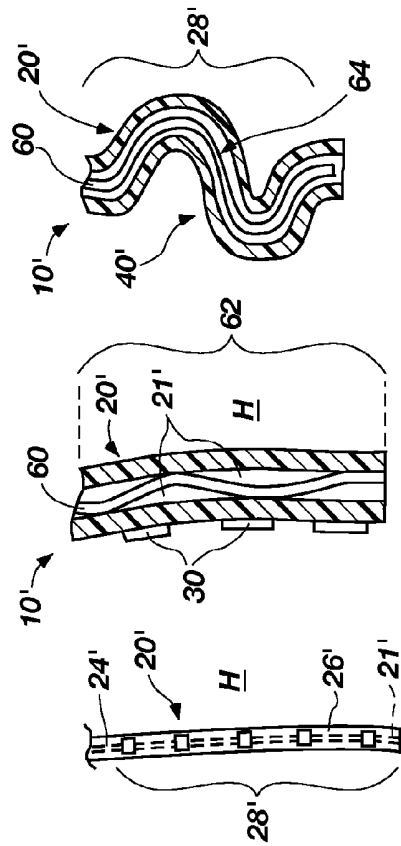

FIG. 8

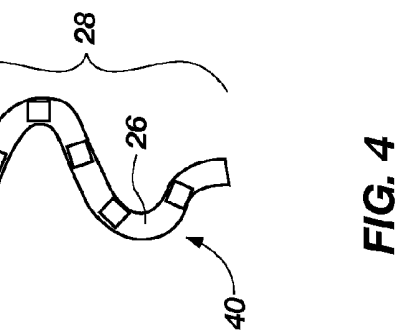

FIG. 9

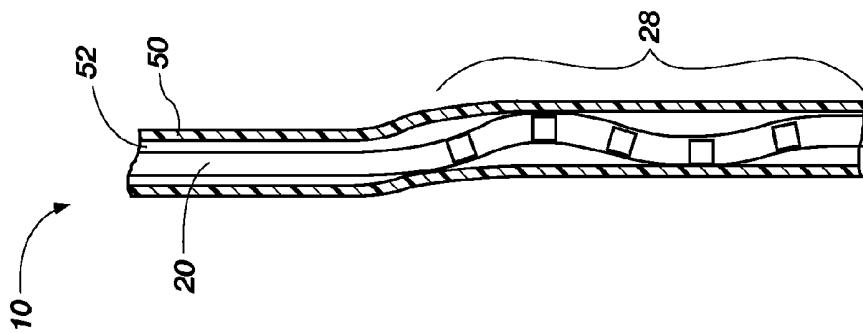

FIG. 3

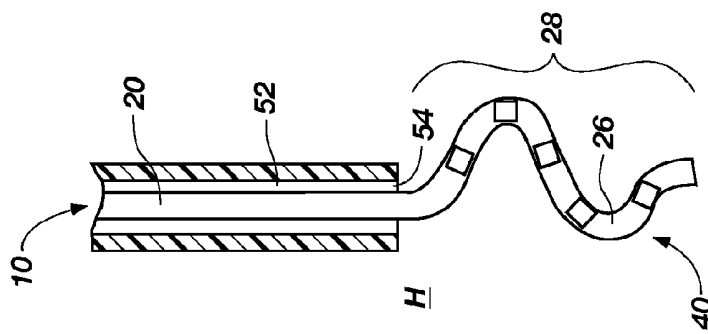

FIG. 4

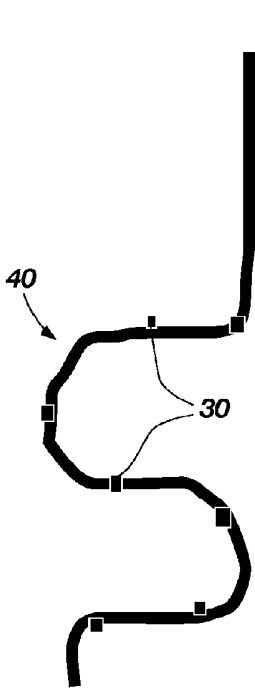

FIG. 10

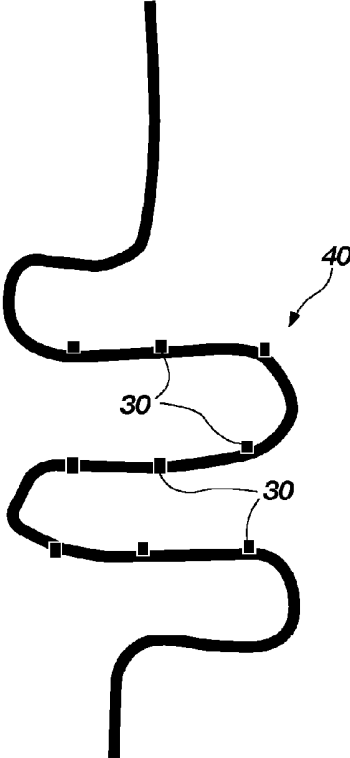

FIG. 11

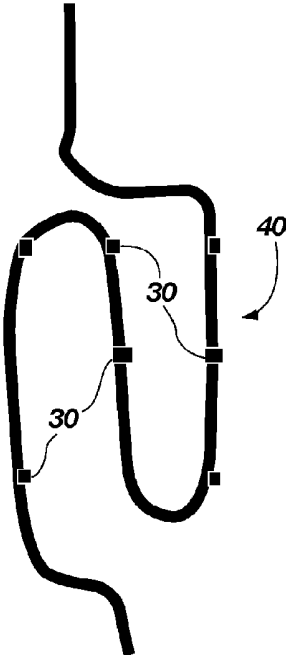

FIG. 12

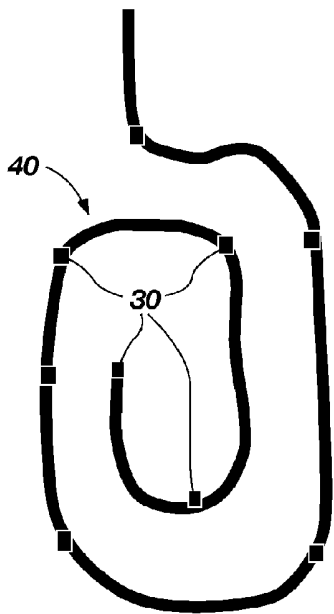

FIG. 13

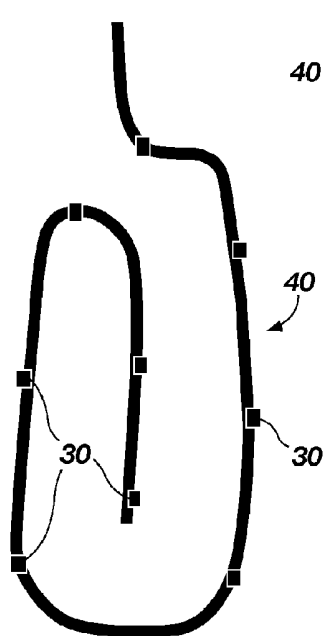

FIG. 14

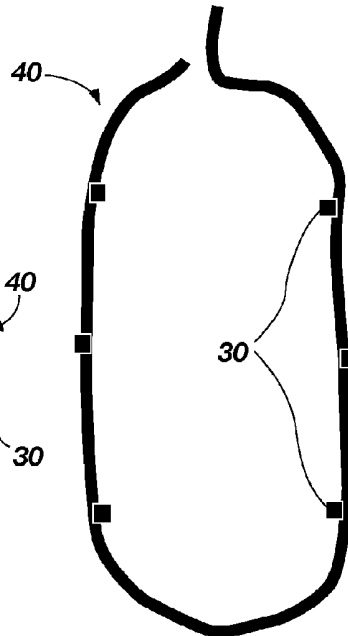

FIG. 15

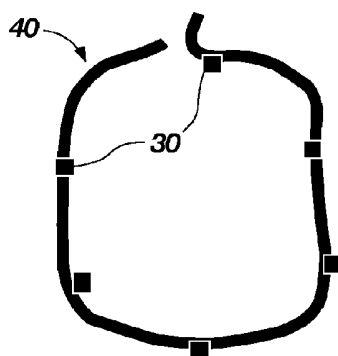

FIG. 16

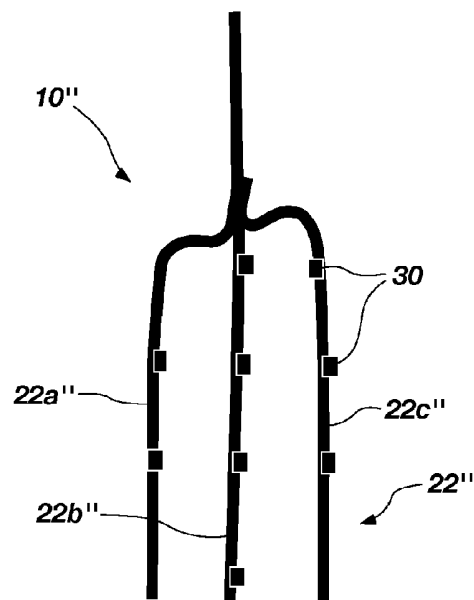

FIG. 17

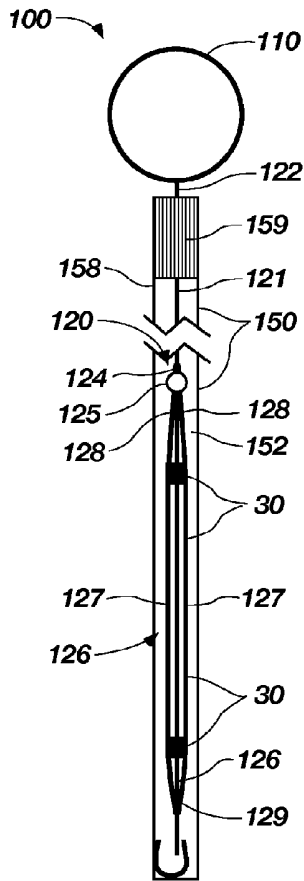

FIG. 18

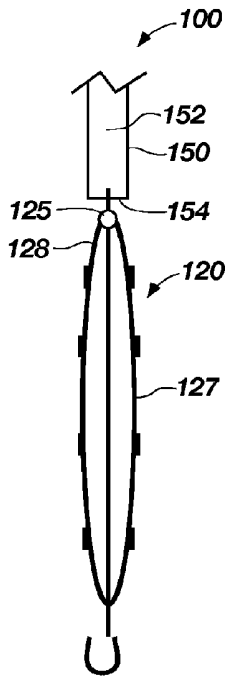

FIG. 19

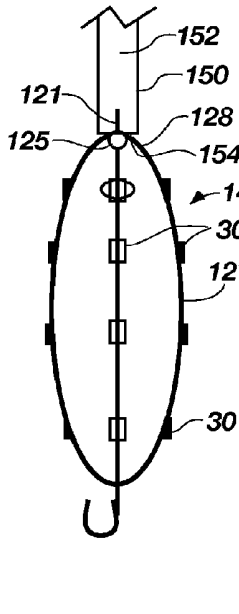

FIG. 20

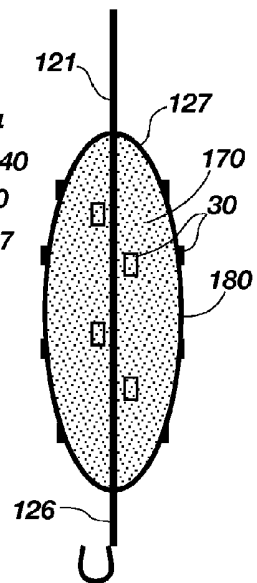

FIG. 21

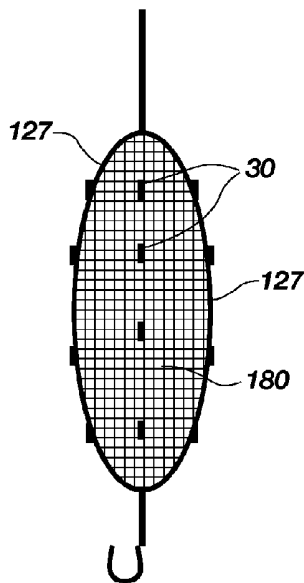

FIG. 22

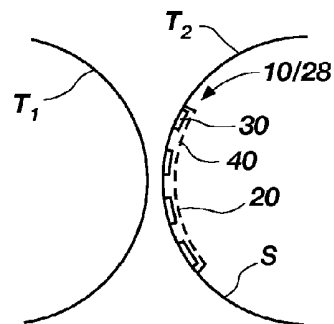

FIG. 23

LARGE SURFACE AREA TEMPERATURE SENSING

CROSS-REFERENCE TO RELATED APPLICATION

This application is a divisional of U.S. patent application Ser. No. 12/406,771, filed on Mar. 18, 2009, titled LARGE SURFACE AREA TEMPERATURE SENSING DEVICE (“the ’771 Application”). The ’771 Application claims the benefit of the Mar. 18, 2008, filing date of U.S. Provisional Patent Application No. 61/037,624 titled LARGE SURFACE AREA TEMPERATURE SENSING DEVICE (“the ’624 Provisional Application”) under 35 U.S.C. §119(e). The entire disclosure of each of the foregoing patent applications is hereby incorporated herein.

TECHNICAL FIELD

The present invention relates generally to apparatuses for monitoring temperatures of an internal surface of a hollow organ in the body of a subject and, more specifically, to temperature monitoring apparatuses that are configured to monitor temperatures at different locations spread over an area of an internal surface of a hollow organ. The present invention also relates to methods in which temperatures across areas of an internal surface of a hollow organ are monitored, including techniques in which an adjacent tissue or organ is heated or cooled.

BACKGROUND OF RELATED ART

A variety of techniques have been developed in which tissues or organs in a patient’s body are heated or cooled. Tissues may be heated by a variety of techniques, including high frequency ultrasound, radiofrequency treatments, laser treatments, use of infrared radiation, and by direct application of thermal energy. Cooling is often effected cryogenically. Techniques that heat and cool tissues may be collectively referred to as “thermal techniques.”

Thermal techniques are useful for diagnosing a variety of disease states and for treating a variety of disease states. More specifically, thermal techniques may be used to diagnose and/or treat cancerous tissues, to destroy diseased tissues, to congeal blood, and to perform a variety of other diagnostic and surgical procedures. Examples of organs that may be subjected to thermal techniques include the heart, the lungs, gastrointestinal organs, the liver, the pancreas, urological organs, prostates, reproductive organs, and skin.

The degree of heating or cooling that is required to optimize the efficiency of some thermal techniques may adversely affect tissues or organs that are adjacent to a treated tissue or organ. For example, a great deal of heat is generated when left atrial ablation techniques are used to treat atrial fibrillation in human subjects. In addition to heating and treating the diseased tissue in the heart H, the esophagus E, which is adjacent to the left atrium LA of the heart H, as shown in FIG. 1, may also be heated. As FIG. 1 illustrates, a typical human esophagus E typically has a narrow oval shape that resembles a pancake, with a large portion of the outer surface of the esophagus E located next to or in contact with the left atrium LA, although the size, shape, and/or position of the esophagus E may vary. In an average human adult, about 58 mm of the length and the majority of the front side of a 14 mm diameter esophagus E is located in proximity to or contacts the left atrium LA. As a consequence of this intimate arrangement between the

esophagus E and the left atrium LA, the heat generated during left atrial ablation may damage the esophagus E and may, in some cases, create an esophageal fistula. Unfortunately, the complications that arise from esophageal fistula often do not present themselves until weeks after the procedure and, in many cases, at too late a time to treat and/or cure the sometimes fatal damage that has been done.

In recognition of the potentially dire consequences of overheating the esophagus E during left atrial ablation, some physicians have started using catheters with single temperature sensors to monitor the temperature within the subject’s esophagus E. Typically, a catheter with a size of 9 French (about 3 mm diameter) to about 18 French (about 64 mm diameter) is used in conjunction with a conventional temperature sensor (e.g., an esophageal stethoscope available from Smiths Medical of Hythe, Kent, United Kingdom). If the sensed temperature reaches a predetermined level, the physician may discontinue the left atrial ablation momentarily to allow the esophagus E to cool. The effectiveness of these techniques is limited, however, as a single temperature sensor may only monitor heat at a single location within the relatively large area of the esophageal wall located adjacent to the left atrium LA.

In an apparent effort to reduce the likelihood of esophageal fistula during left atrial ablation procedures, a variety of different types of inflatable devices have been developed. Some inflatable devices are configured to cool the esophagus E during left atrial ablation. Other inflatable devices are configured to ensure contact between one or more temperature sensors and the interior surface of the front of the esophageal wall. Despite assertions to the contrary, since the esophagus E is confined between the left atrium LA of the relatively rigid heart H and the even more rigid vertebral column VC (see FIG. 1), any change in the shape of the esophagus E by inflating a device that has been introduced into the esophagus E merely pushes or distends the esophagus E closer to, or into more intimate contact with, the left atrium LA. The obvious result of such movement or distension is an increase in the likelihood that a left atrial ablation procedure will cause an esophageal fistula. In addition, use of an inflatable device will undesirably prevent a subject from swallowing during the typically lengthy (two to four hour) procedure, which may unnecessarily require that the subject be placed under general anesthesia during the procedure.

SUMMARY

The present invention includes various embodiments of temperature probes configured to be positioned against internal organ surfaces. A temperature probe that incorporates teachings of the present invention includes an elongate member and a plurality of temperature sensors carried at discrete locations along the length of the elongate member. When disposed within the interior of a hollow organ, a section of the elongate member is configured to have a substantially two-dimensional arrangement that arranges the temperature sensors in an area array. The arrangement of the shaped section of the elongate member is referred to as a “substantially two-dimensional arrangement” to account for the thicknesses of the elongate element and the temperature sensors carried thereby, as well as for any slight deviations of the elongate member from a desired plane for the two-dimensional arrangement.

A substantially two-dimensional arrangement of a portion of a temperature probe of the present invention may, in some embodiments, be defined during manufacture of the tem-

perature probe or apparatus (e.g., catheters, guide wires, shaping wires, etc.) that are to be used therewith. In other embodiments, a temperature probe or an apparatus that is configured for use therewith may be configured to enable a physician to define the substantially two-dimensional arrangement.

In some embodiments, the elongate member comprises a flexible element with a section that, in a relaxed state, is pre-shaped to a desired, substantially two-dimensional arrangement. Elongate members with such characteristics may take on substantially linear, or one-dimensional, configurations when introduced into a linear catheter under stress but, upon removal of the pre-shaped section from the catheter, the pre-shaped section returns to its relaxed state, in which it has a substantially two-dimensional arrangement.

In other embodiments, the elongate member is an element that has a substantially linear, or one dimensional, configuration, but includes a section that may be formed into a substantially two-dimensional arrangement of desired configuration. A section of an elongate member that is ordinarily substantially linear may take on a substantially two-dimensional arrangement when a wire that includes a section with the substantially two-dimensional arrangement is introduced into a lumen of the elongate member. Such a wire may itself be somewhat flexible or selectively flexible (e.g., depending upon its temperature, etc.), and its introduction into the interior of a hollow organ of a subject's body may be enabled by rigidity of a proximal and/or intermediate portion of the elongate member, a property (e.g., shape memory, etc.) of the material from which the wire is formed, or by any other suitable means. When the shaped portion of the wire is introduced into a corresponding flexible section of the elongate member, that section of the elongate member may assume the substantially two-dimensional arrangement.

Other embodiments of temperature probes of the present invention include mechanisms for transforming substantially linear sections of elongate members to two-dimensional arrangements. In one such embodiment, an elongate element comprises a control wire, along with a multi-element portion along a portion of the length of the control wire. The multi-element portion includes at least two parallel arms that carry temperature sensors. While the multi-element portion is contained within a catheter, it may have a substantially linear configuration. Once the catheter has been introduced into the interior of a hollow organ, the control wire may be moved distally to push the multi-element portion out of a distal end of the catheter. The control wire may then be drawn back toward the distal end of the catheter, which engages an actuator associated with the at least two parallel arms and causes them to bow outwardly, forcing the multi-element portion into a substantially two-dimensional arrangement, such as a loop.

Other techniques for causing a section of a temperature probe to assume a substantially two-dimensional configuration (e.g., aspiration of air from a lumen extending through a section of the temperature probe, introduction of pressure into a lumen extending through a section of the temperature probe, manipulation of a section of a temperature probe following its introduction into the body of a subject, etc.) are also within the scope of the present invention.

The present invention includes techniques for introducing a temperature probe into the body of a subject with the temperature probe in a substantially linear, or one-dimensional, configuration, then allowing or causing a section of an elongate member of the temperature probe to assume the

substantially two-dimensional arrangement when that section of the temperature probe is at a desired location within the subject's body.

In addition to including various embodiments of temperature probes, the present invention also includes embodiments of methods, or procedures, in which the temperatures at various locations over an area of a body tissue are monitored. When such a procedure is conducted, a first tissue or organ of a subject's body is subjected to a thermal technique while temperature is monitored over an area of an adjacent, second tissue or organ of the subject's body. In some embodiments, the temperature of the second tissue or organ may be monitored without substantial deformation of the second tissue or organ, without substantial displacement of the second tissue or organ, and/or without preventing the second tissue or organ from functioning. Additionally, if any portion of the monitored area approaches a potentially damaging (cold or hot) temperature, precautionary measures may be taken. Various embodiments of such precautionary measures include, but are not limited to, temporary termination of the thermal technique, movement of the affected portion of the second tissue or organ away from the first tissue or organ, and/or changing the temperature of the affected portion of the second tissue or organ.

In a specific embodiment, the method of the present invention may be effected during left atrial ablation, which is a surgical procedure that may be used to treat atrial fibrillation. During a left atrial ablation procedure, temperature may be monitored at a plurality of locations spaced over an area of an interior surface of a front portion of a subject's esophageal wall that is located adjacent to the left atrium of the subject's heart. Such temperature monitoring may be effected without any substantial change in the shape of the esophagus, without any substantial displacement of the monitored portion of the esophagus, and without blocking the esophagus or otherwise preventing the subject from swallowing. If any portion of the sensed area approaches a potentially damaging temperature, cautionary measures may be taken. In various embodiments, the left atrial ablation procedure may be temporarily terminated, the heated portion of the esophagus may be moved away from the left atrium, and/or the heated portion of the esophagus may be cooled.

Other embodiments of procedures in which thermal techniques are employed are also within the scope of the present invention, including, without limitation, monitoring the temperature of the trachea during ablation of the pulmonary vein; monitoring the temperature of the ureters and/or colon during thermal treatment of the prostate; monitoring the temperature of and, optionally, flattening a portion of the duodenum of the small intestine during thermal treatment of the liver (e.g., to treat hepatic carcinoma, etc.); monitoring the temperature of the cystic duct, gall bladder, and/or stomach during thermal treatment of the liver; monitoring brain temperature through tissues lining the nasal cavities; monitoring the temperature of tissues in the nasal cavities during thermal pharyngeal procedures; and monitoring tissues of or adjacent to the kidneys while breaking up kidney stones.

Other aspects, as well as various features and advantages, of the present invention will become apparent to those of ordinary skill in the art through consideration of the ensuing description, the accompanying drawings, and the appended claims.

BRIEF DESCRIPTION OF THE DRAWINGS

In the drawings:

FIG. 1 is a cross-sectional representation of a portion of a human body illustrating the relationship between the esophagus and the heart;

FIG. 2 depicts an embodiment of a temperature probe with an elongate member that includes a section with a substantially two-dimensional arrangement and temperature sensors arranged along the section of the elongate member in such a way that, when the section is in its substantially two-dimensional arrangement, the temperature sensors are arranged in an area array;

FIGS. 2A and 2B illustrate different embodiments of the elongate members of a temperature probe of the present invention;

FIG. 3 illustrates the embodiment of temperature probe shown in FIG. 2, in a substantially linear, or one-dimensional, configuration when disposed within a lumen of a catheter having a substantially linear, or one-dimensional, configuration;

FIG. 4 depicts relaxation of a segment of the embodiment of temperature probe shown in FIG. 2 to its substantially two-dimensional arrangement upon exiting a distal end of the catheter of FIG. 3;

FIG. 5 shows an embodiment of a temperature probe with an elongate member that includes a flexible section that, in its relaxed state, may be substantially linear, or one-dimensional, and that includes a flexible section that carries a plurality of temperature sensors;

FIG. 6 illustrates an embodiment of a shaped wire with a section that, in its relaxed state, has a substantially two-dimensional arrangement;

FIG. 7 depicts introduction of the embodiment of temperature probe shown in FIG. 5 into an interior of a hollow organ of a subject;

FIG. 8 depicts introduction of the shaped wire of FIG. 6 into the temperature probe of FIG. 5, with the section that has the substantially two-dimensional arrangement deformed to a substantially linear, or one-dimensional, configuration;

FIG. 9 shows the flexible section of the temperature probe of FIGS. 5 and 6 in a substantially two-dimensional arrangement when the shaped portion of the wire of FIG. 6 assumes its substantially two-dimensional arrangement within the flexible section;

FIGS. 10 through 17 depict various embodiments of two-dimensional configurations in which a section of a temperature probe of the present invention may be arranged;

FIGS. 18 through 20 illustrate an embodiment of temperature probe configured to be mechanically arranged in a substantially two-dimensional arrangement upon being positioned at or near a desired location;

FIGS. 21 and 22 depict embodiments of temperature probes that include similar elements to the embodiment shown by FIGS. 18 through 20; and

FIG. 23 schematically depicts use of an embodiment of a temperature probe of the present invention in conjunction with a procedure in which a thermal technique is employed.

DETAILED DESCRIPTION

As shown in FIG. 2, a temperature probe 10 according to an embodiment of the present invention includes an elongate member 20 with a proximal portion 22, an intermediate portion 24, and a distal portion 26. In addition, temperature probe 10 includes a plurality of temperature sensors 30

located along one or both of intermediate portion 24 and distal portion 26. More specifically, temperature sensors 30 are positioned along a section 28 of elongate member 20 that is configured to have a substantially two-dimensional arrangement 40 when placed adjacent to or against an area of a surface of a tissue or organ in the body of a subject. Section 28 may also carry other elements, such as radioopaque markers, echogenic markers, other sensors, and the like. The shape of the substantially two-dimensional arrangement 40 distributes three or more temperature sensors 30 over an area (e.g., an area array in the depicted embodiment) that is relatively large when compared with the miniscule area covered by elongate member 20 itself. Temperature sensors 30 may be arranged across an area array in which at least two sensors 30 spaced laterally (x-axis X) apart from each other a first distance that exceeds a width of elongate member 20 and at least two sensors 30 spaced vertically (y-axis Y) apart from each other a second distance that is at least as great as the first distance.

Elongate member 20 may, in various embodiments, have a length of about 20 cm to about 200 cm. The substantially two-dimensional arrangement 40 may have a width that exceeds a diameter of elongate member 20 by at least ten percent. In a specific embodiment, the substantially two-dimensional arrangement 40 covers an area with a width of about 10 mm to about 30 mm and a length of about 40 mm to about 80 mm, although substantially two-dimensional arrangements that cover narrower areas, wider areas, shorter areas, and longer areas are also within the scope of the present invention.

In some embodiments, such as that depicted by FIG. 2, section 28 of elongate member 20 may be configured in the substantially two-dimensional arrangement 40 while in a relaxed state. The material from which elongate member 20 is formed may, in such embodiments, be somewhat flexible and elastic, at least under certain conditions (e.g., when placed under a load, with or without other conditions), to enable elongation of section 28 from the substantially two-dimensional arrangement 40 to a more linear, substantially one-dimensional, configuration. For example, section 28 may be elongated when placed under a load within the lumen 52 of a catheter 50, as shown in FIG. 3.

A variety of materials are suitable for forming a pre-shaped but flexible elongate member 20 (or at least section 28 thereof), including plastics and metal alloys. In embodiments where section 28 of elongate member 20 is formed from a plastic, the plastic may comprise a polyester, a polyurethane, a latex, polyvinyl chloride, and the polyether block amide marketed as PEBAX®. Metals and/or metal alloys that may be used to form elongate member 20 include, but are not limited to, shape memory alloys such as the nickel-titanium alloy referred to as NITINOL (for nickel titanium naval ordinance laboratory), steel, nickel-titanium, cobalt-chromium, and the cobalt-based alloy available under the trade name ELGILOY®. An elongate member 20 that is formed from a metal or metal alloy may, in some embodiments, be coated with a softer polymer to prevent damage to the tissues and organs of the body of a subject into which temperature probe 10 is introduced. In some embodiments, the entire elongate member 20 may be formed from the same material, while other embodiments of elongate member 20 have hybrid constructions, such as a metal proximal portion 22 joined to a plastic or shape memory alloy distal portion 26.

As depicted by FIG. 2A, in some embodiments, including embodiments in which elongate member 20 is formed from a plastic, elongate member 20 may comprise a tubular

member with one or more lumens **21a**, **21b**, **21c** (three are shown) extending therethrough. Lumen **21a** of such an elongate member **20** may be configured to accommodate wires (e.g., thermally conductive elements or electrically conductive wires **32** that lead to temperature sensors **30**, to other sensors, etc.) or other elements of temperature probe **10**. Lumen **21b** may be configured to transport fluids into (e.g., fluids that provide a heat sink, cooled fluids to decrease a temperature of the sensed tissue, heated fluids to increase a temperature of the sensed tissue, etc.) or out of the subject's body, or to provide a pathway by which other medical devices may be introduced into the subject's body. Lumen **21c** of elongate member **20** may be configured to receive a guide wire.

As an alternative to wires **32** that extend through an interior (e.g., through a lumen **21a**) of elongate member **20**, wires **32** may be carried upon an exterior of elongate member **20** (including embodiments in which elongate member **20** includes one or more lumens **21a**, **21b**, **21c**, as well as embodiments in which elongate member **20** lacks lumens, or has a solid cross-section), as illustrated by FIG. 2B. Various embodiments of externally carried wires **32** include wires that are defined by etching a metal film formed on an external surface of elongate member **20**, wires that are stamped or printed onto the external surface of elongate member **20**, and wires that are discrete from, but carried by (e.g., wrapped around, etc.) the external surface of elongate member **20**. Of course, in embodiments where elongate member **20** is formed from a metal or metal alloy, electrically insulative elements (e.g., a dielectric coating, etc.) (not shown) may electrically isolate wires **32** that are carried by the exterior surface of elongate member **20** from the material of elongate member **20**.

As depicted by FIG. 2B, in some embodiments, elongate member **20** may have a solid cross section.

Each temperature sensor **30** of temperature probe **10** may comprise any suitable type of temperature sensor known in the art. In various embodiments, thermocouples or thermistors that have been swaged to metal or thermally conductive (e.g., platinum, platinum-iridium, gold, etc.) sensors may be used as temperature sensors **30**. Each temperature sensor **30** may comprise a single element configured to detect a single temperature at a particular location. Alternatively, one or more temperature sensors **30** of a temperature probe **10** of the present invention may include a plurality of ganged temperature sensing elements, each of which may sense and/or report a different temperature to provide a more accurate temperature reading at a particular location.

Wires **32** that communicate with temperature sensors **30** (or with individual temperature sensing elements of a sensor **30**) extend proximally along elongate member **20** to a suitable connector **34** associated with proximal portion **22** of elongate member **20**. In some embodiments, connector **34** may comprise a known **400** series connector or a known series **700** connector, such as, or similar to, those manufactured by Datex Ohmeda, GE Medical, Nihon Kohden, or Vital Signs, Inc.

Connector **34** enables connection of wires **32** and, thus, thermal sensors **30** to a suitable temperature monitor (not shown) that, in turn, communicates with a processing element (not shown) associated with a temperature display system **36**. In the depicted embodiment, display system **36** includes a display element **37** that shows the temperatures **38a**, **38b**, etc., monitored at various locations that correspond to the locations of temperature sensors **30** in the substantially two-dimensional arrangement **40** of section **28** of elongate member **20**. Temperatures **38a**, **38b**, etc., may be

visually arranged in a manner that corresponds to the physical arrangement of temperature sensors **30** across the substantially two dimensional configuration **40**. Additionally, display system **36** may clearly identify the warmest and coolest sensed temperatures **38a**, **38b**, etc. (e.g., by color, such as red and blue, respectively; by fast and slow flashing, respectively; etc.). Display system **36** may also present a rate **39** at which a sensed temperature is changing. The rate of temperature change may be displayed numerically or, as depicted, graphically.

With reference to FIG. 3, an embodiment of a method for introducing a temperature probe **10** into a body of a subject is depicted. Specifically, temperature probe **10** is introduced into a lumen **52** of a substantially linear, or one-dimensional, catheter **50**. Catheter **50** is sufficiently rigid to cause section **28** of elongate element **20** of temperature probe **10** to flex and, thus, to straighten while catheter **50** maintains its substantial linearity. In some embodiments, catheter **50** may also be sufficiently flexible to move through curved cavities or vessels. With the non-linear, substantially two-dimensional arrangement **40** (FIG. 2) of elongate element **20** of temperature probe **10** confined within lumen **52** of catheter **50** in a substantially linear configuration, temperature probe **10** may be easily introduced into a hollow area H within the body of a subject.

Once distal portion **26** of elongate element **20** of temperature probe **10** has been positioned within hollow area H, distal portion **26** and section **28** may be pushed out of a distal end **54** of lumen **52** and into hollow area H, where section **28** may assume its relaxed, substantially two-dimensional arrangement **40**, as shown by FIG. 4.

As an alternative to the use of a catheter to straighten temperature probe **10** and introduce a distal portion **26** of the same into hollow area H, a proximal end of a guide wire whose distal end has already been introduced into hollow area H may be introduced into a lumen **21c** (FIG. 2A) of elongate member **30**. The rigidity of the guide wire may be sufficient to straighten section **28** of elongate member **30**, facilitating its introduction into hollow area H. Once section **28** has been introduced to a desired location, the guide wire may be removed from lumen **21c**, allowing section **28** to assume the substantially two-dimensional arrangement **40**.

Another embodiment of temperature probe **10'** of the present invention is depicted by FIGS. 5 through 9. As depicted by FIG. 5, temperature probe **10'** comprises a substantially one-dimensional elongate member **20'** with the same features as elongate member **20** (FIG. 2), with the primary exception being that section **28'** of elongate member **20'** is not shaped to have a substantially two-dimensional configuration **40** (FIG. 2). Instead, section **28'** of elongate member **20'** of temperature probe **10'** is flexible, and may be deformed to take on a substantially two-dimensional configuration **40** (FIG. 2).

As depicted by FIGS. 6 and 7, a lumen **21'** that extends through the length of elongate member **20'** is configured to receive a shaped wire **60**. As shown in FIG. 6, prior to its introduction into lumen **21'**, shaped wire **60** includes a section **62** that, in its relaxed state, has a substantially two-dimensional arrangement **64**. Shaped wire **60** is a flexible element that may be substantially straightened. In various embodiments, shaped wire **60** may be formed from a somewhat rigid, yet flexible plastic or a metal or metal alloy, such as a shape memory alloy that is flexible at room temperature, but that becomes rigid when heated (e.g., to a subject's body temperature, etc.).

FIG. 7 illustrates the introduction of distal and intermediate portions **26'** and **24'** of elongate member **20'** of tem-

perature probe 10 into a hollow area H of the body of a subject. As elongate member 20' is introduced into hollow area H, so are temperature sensors 30 that are carried by section 28'. Due to its substantially linear, or one-dimensional configuration, known techniques may be used to introduce elongate member 20' into hollow area H.

Thereafter, shaped wire 60 may be introduced into lumen 21' of elongate member 20' of temperature probe 10', as illustrated by FIG. 8. As shaped wire 60 is introduced into lumen 21', section 62 of shaped wire 60 may be deformed (e.g., by the rigidity of a proximal portion 22' and/or intermediate portion 24' of elongate member 20' (FIG. 5), by temperature-dependent flexibility, etc.) to render section 62 substantially linear, or to have a one-dimensional configuration. Such deformation of section 62 enables shaped wire 60 to be easily introduced into a temperature probe 10' that has been inserted into hollow area H.

When section 62 (FIG. 6) of shaped wire 60 has been introduced into section 28' of elongate member 20' of temperature probe 10', section 62 may assume the substantially two-dimensional arrangement 64 (e.g., due to flexibility of section 28', upon being heated to or beyond a transition temperature, etc.), as depicted by FIG. 9. As section 62 of shaped wire 60 assumes the substantially two-dimensional arrangement 64, the flexibility of section 28' also allows it to be drawn into a corresponding, substantially two-dimensional arrangement 40'. With section 28' of elongate member 20' in the substantially two-dimensional arrangement 40', temperature sensors 30 (FIG. 5) that are carried by section 28' are spread across an area defined by the substantially two-dimensional arrangement 40'.

Referring now to FIGS. 10 through 16, various embodiments of substantially two-dimensional arrangements 40 are depicted along with possible arrangements of temperature sensors 30. Specifically, FIGS. 10 through 12 show different embodiments of serpentine, or S, arrangements, while FIGS. 13 and 14 depict examples of spiral, or pigtail, arrangements, and FIGS. 15 and 16 illustrate different looped arrangements. Of course, substantially two-dimensional arrangements 40 of other shapes and configurations are also within the scope of the present invention.

FIG. 17 illustrates a forked embodiment of temperature probe 10" with an enlarged distal portion 22" that includes two or more substantially parallel arms 22a", 22b", etc. (the depicted embodiment includes a distal portion 22" with three arms 22a", 22b", and 22c"). As illustrated, each arm 22a", 22b", and 22c" carries at least one temperature sensor 30. In some embodiments, one or more arms 22a", 22b", 22c", etc., may carry more than one temperature sensor 30.

FIGS. 18 through 20 illustrate another embodiment of temperature probe 100, which is configured to be mechanically arranged in a substantially two-dimensional arrangement upon being positioned at or near a desired location.

As shown in FIG. 18, temperature probe 100 includes an introductory catheter 150, an elongate member 120 at least partially carried by introductory catheter 150, and a plurality of temperature sensors 30 carried by a distal portion 126 of elongate member 120.

Elongate member 120 includes a proximally located pull wire 121. A user engagement element 110 is associated with a proximal end 122 of pull wire 121 to facilitate movement of elongate member 120 through a lumen 152 of introductory catheter 150. Pull wire 121 may extend along substantially the entire length of elongate member 120. In the depicted embodiment, an intermediate portion 124 of pull wire 121 extends through a slip ring 125, to which proximal ends 128 of two or more loop wires 127 are secured. Each

loop wire 127 carries at least one temperature sensor 30 and, as depicted, at least one loop wire 127 may carry a plurality of temperature sensors 30. Distal ends 129 of loop wires 127 are secured to pull wire 121 at or near its distal end 126. In some embodiments, distal ends 129 of loop wires 127 may be fixedly secured to pull wire 121.

Distal end 126 of pull wire 121 may be configured or covered with an element that prevents trauma to the tissues of a subject as pull wire 121 is advanced distally and distal end 126 exits introductory catheter 150.

In the arrangement shown by FIG. 18, loop wires 127 are contained within lumen 152 of introductory catheter 150. This arrangement facilitates the introduction of a distal portion of temperature probe 100 into a hollow area of a subject's body. Once the distal portion of temperature probe 100 has been placed at a desired location, elongate member 120 may be pushed distally through lumen 152 until proximal ends 128 of loop wires 127 and slip ring 125 have exited a distal end 154 of lumen 152 of introductory catheter 150, as depicted by FIG. 19.

Thereafter, as shown in FIG. 20, pull wire 121 may be proximally withdrawn. As pull wire 121 is proximally withdrawn, slip ring 125, proximal ends 128 of loop wires 127, and/or an engagement element (not shown) associated with slip ring 125 or with proximal ends 128 engage distal end 154 of introductory catheter 150. As pull wire 121 is further withdrawn and proximal ends 128 are held into place relative to distal end 154, loop wires 127 bow outwardly, providing a distal portion of temperature probe 100 with a substantially two-dimensional arrangement 140. While the distal portion of temperature probe 100 is in the substantially two-dimensional arrangement 140, temperature sensors 30 that are carried by loop wires 127 are spread across an area defined by the substantially two-dimensional arrangement 140. The area over which loop wires 127 spread depends, of course, upon the degree to which pull wire 121 is withdrawn.

With reference again to FIG. 18, user engagement element 110 and pull wire 121 may be associated with each other in such a way as to impart a user with control over an orientation of the substantially two-dimensional arrangement 140 (FIG. 20). In some embodiments, user engagement element 110 and pull wire 121 may be manipulated to enable deflection (e.g., of up to about 5°, etc.) of the substantially two-dimensional arrangement 140 in any direction relative to an axis of elongate member 120.

A position of pull wire 121 relative to introductory catheter 150 and, thus, the substantially two-dimensional arrangement 140 (FIG. 20) of the distal portion of temperature probe 100, may be maintained by causing a locking element 159 associated with a proximal end 158 of introductory catheter 150 to engage a proximal portion 122 of pull wire 121 (e.g., by screwing locking element 159 down into proximal portion 122, etc.).

Instead of requiring that distal portion 126 of pull wire 121 be partially withdrawn into lumen 152 of introductory catheter 150 to expand loop wires 127, in other embodiments, a flexible element, such as a balloon 170 enclosed within a mesh basket 180 or a mesh basket 180 alone, may be secured to loop wires 127, as shown in FIGS. 21 and 22, respectively. Balloon 170 may be inflated by known techniques. Mesh basket 180 may comprise a compressed element that, when removed from lumen 152 of introductory catheter 150, automatically expands. Mesh basket 180 may have a substantially two-dimensional configuration (e.g., having a narrow oval, or pancake, cross-sectional shape, etc.) so as to minimize or even prevent manipulation of the shape, displacement, and/or blockage of the hollow organ

within which either of these elements are placed. In embodiments including a balloon **170**, mesh basket **180** may constrain the shape of the balloon **170** to the substantially two-dimensional configuration. In some embodiments, balloon **170** or mesh basket **180** may carry temperature sensors **30**.

With reference now to FIG. **23**, an embodiment of a method, or procedure, is depicted in which an embodiment of temperature probe **10** of the present invention is used to monitor temperatures at a plurality of locations across an area of a surface **S** of second tissue or an organ T_2 in the body of a subject as a first tissue or organ T_1 of the subject's body is subjected to a thermal technique. A plurality of temperature sensors **30** distributed across an area defined by a substantially two-dimensional arrangement **40** of a section **28** of an elongate member **20** is placed against surface **S**. Section **28** may be placed against surface **S** without substantially deforming surface **S** or the shape of second tissue or organ T_2 of which surface **S** is a part, without substantially displacing any part of second tissue or organ T_2 , and/or without preventing second tissue or organ T_2 from functioning properly as the temperature of surface **S** is monitored. In some embodiments, section **28** may deform slightly to conform to a shape of surface **S**.

If any portion of the monitored area of surface **S** approaches a potentially damaging (cold or hot) temperature, precautionary measures may be taken. Various embodiments of such precautionary measures include, but are not limited to, temporary termination of the thermal technique, changing the temperature of the affected portion of second tissue or organ T_2 , and/or movement of the affected portion of second tissue or organ T_2 away from first tissue or organ T_1 . Various embodiments for moving the affected portion of second tissue or organ T_2 include, but are not limited to, deformation of second tissue or organ T_2 to a flattened (e.g., narrowed oval) shape (e.g., by modifying an area occupied by the substantially two-dimensional arrangement **40** of section **28**, etc.), manipulation of a position of temperature sensor **10** within the body of the subject to move a portion of second tissue or organ T_2 , or any other suitable technique for moving tissue with temperature sensor **10**.

Although the foregoing description contains many specifics, these should not be construed as limiting the scope of the present invention, but merely as providing illustrations of some embodiments. Similarly, other embodiments of the invention may be devised which lie within the scope of the present invention. Features from different embodiments may be employed in combination. The scope of the invention is, therefore, indicated and limited only by the appended claims and their legal equivalents, rather than by the foregoing description. All additions, deletions and modifications to the invention as disclosed herein which fall within the meaning and scope of the claims are to be embraced thereby.

What is claimed is:

1. A left atrial ablation method, comprising:

introducing a temperature probe comprising a single elongated element into an esophagus of an individual, the single elongated element including a proximal portion that is substantially linear and a temperature-sensing portion continuous with a distal end of the proximal portion and including a plurality of divergent bends, the temperature-sensing portion having substantially a same cross-sectional shape and dimensions as the proximal portion;

placing the temperature-sensing portion of the single elongated element of the temperature probe and a plurality of temperature sensors arranged sequentially

along a length of the temperature-sensing portion, spaced apart along the length of the temperature-sensing portion, and arranged in an area array by the plurality of divergent bends of the temperature-sensing portion against an interior surface of a portion of the esophagus located adjacent to a left atrium of a heart of the individual, the act of placing the temperature-sensing portion including positioning the plurality of temperature sensors in the area array against the interior surface of the portion of the esophagus without preventing the esophagus from functioning normally; with the plurality of temperature sensors positioned against the interior surface of the portion of the esophagus, ablating abnormal tissue of a wall of the left atrium of the heart of the individual from an interior of the left atrium; and

monitoring a temperature of the interior surface of the portion of the esophagus with the plurality of temperature sensors while ablating the abnormal tissue.

2. The left atrial ablation method of claim **1**, wherein placing the temperature-sensing portion of the single elongated element of the temperature probe occurs while visualizing a location of the temperature-sensing portion of the single elongated element of the temperature probe.

3. The left atrial ablation method of claim **2**, wherein visualizing the location of the temperature-sensing portion of the single elongated element of the temperature probe comprises fluoroscopy.

4. The left atrial ablation method of claim **2**, wherein visualizing the location of the temperature-sensing portion of the single elongated element of the temperature probe comprises ultrasound.

5. The left atrial ablation method of claim **1**, wherein placing comprises placing the temperature-sensing portion to distribute the plurality of temperature sensors over an area having a height of about 40 mm to about 80 mm and a width of about 10 mm to about 30 mm against the interior surface of the portion of the esophagus.

6. The left atrial ablation method of claim **1**, wherein placing the temperature-sensing portion of the single elongated element of the temperature probe against the interior surface of the portion of the esophagus located adjacent to the left atrium of the heart of the individual comprises placing the temperature-sensing portion against a front surface of the esophagus.

7. The left atrial ablation method of claim **1**, wherein introducing comprises introducing the temperature-sensing portion into the esophagus of the individual in a straightened configuration and enabling the temperature-sensing portion to assume a serpentine configuration once the temperature-sensing portion has been positioned within the esophagus; and

placing comprises placing at least a portion of the serpentine configuration against the interior surface of the portion of the esophagus to position a plurality of temperature sensors carried by the serpentine configuration against the interior surface of the portion of the esophagus.

8. The left atrial ablation method of claim **1**, wherein placing the temperature-sensing portion of the single elongated element of the temperature probe against the interior surface of the portion of the esophagus located adjacent to the left atrium of the heart of the individual occurs without any substantial change in a shape of the esophagus.

9. The left atrial ablation method of claim **1**, wherein placing the temperature-sensing portion of the single elongated element of the temperature probe against the interior

13

surface of the portion of the esophagus located adjacent to the left atrium of the heart of the individual occurs without any substantial displacement of the portion of the esophagus.

10. The left atrial ablation method of claim 1, wherein placing the temperature-sensing portion of the single elongated element of the temperature probe against the interior surface of the portion of the esophagus located adjacent to the left atrium of the heart of the individual occurs without preventing the individual from swallowing.

11. The left atrial ablation method of claim 1, further comprising:

taking precautionary measures if any portion of the interior surface of the portion of the esophagus is heated to a potentially damaging temperature during the acts of ablating and monitoring.

12. The left atrial ablation method of claim 11, wherein taking precautionary measures includes at least temporarily terminating the act of ablating.

13. The left atrial ablation method of claim 11, wherein taking precautionary measures includes cooling the interior

14

surface of the portion of the esophagus that is heated to a potentially damaging temperature.

14. The left atrial ablation method of claim 11, wherein taking precautionary measures includes moving the portion of the esophagus away from the left atrium.

15. The left atrial ablation method of claim 14, wherein moving the portion of the esophagus away from the left atrium includes deforming a shape of the portion of the esophagus.

16. The left atrial ablation method of claim 15, wherein deforming the shape of the portion of the esophagus comprises flattening the portion of the esophagus.

17. The left atrial ablation method of claim 14, wherein moving the portion of the esophagus away from the left atrium includes repositioning the portion of the esophagus within the body of the subject.

18. The left atrial ablation method of claim 14, wherein moving the portion of the esophagus occurs by manipulating the temperature probe.

* * * * *

专利名称(译)	大表面积温度传感		
公开(公告)号	US9668655	公开(公告)日	2017-06-06
申请号	US14/567924	申请日	2014-12-11
[标]申请(专利权)人(译)	CIRCA SCI		
申请(专利权)人(译)	CIRCA科技有限责任公司		
当前申请(专利权)人(译)	CIRCA科技有限责任公司		
[标]发明人	FOJTIK SHAWN P		
发明人	FOJTIK, SHAWN P.		
IPC分类号	A61B5/00 A61B5/01 A61B18/00 A61B34/20 A61B90/00		
CPC分类号	A61B5/742 A61B5/015 A61B5/01 A61B5/4836 A61B5/687 A61B5/6873 A61B18/00 A61B34/20 A61B5/6853 A61B5/6858 A61B5/6859 A61B2018/00357 A61B2018/00404 A61B2018/00529 A61B2018/00547 A61B2018/00577 A61B2018/00797 A61B2034/2063 A61B2090/376 A61B2562/0271 A61B5/0036		
优先权	61/037624 2008-03-18 US		
其他公开文献	US20150094570A1		
外部链接	Espacenet USPTO		

摘要(译)

一种用于监测受试者体内组织或器官表面温度的温度探测器，包括具有基本上二维布置的部分和多个温度传感器，所述多个温度传感器位于由基本上二维布置限定的区域上。这种装置可以与其中使用热技术来诊断疾病状态或治疗患病组织的程序结合使用。具体地，温度探针可用于监测位于处理组织附近的组织或器官表面区域的温度，以防止被监测的组织或器官受到潜在的破坏性温度。

