



US 20190350506A1

(19) **United States**

(12) **Patent Application Publication**

Al-Ali

(10) **Pub. No.: US 2019/0350506 A1**

(43) **Pub. Date: Nov. 21, 2019**

(54) **ADVANCED PULSE OXIMETRY SENSOR**

(71) Applicant: **MASIMO CORPORATION**, Irvine, CA (US)

(72) Inventor: **Ammar Al-Ali**, San Juan Capistrano, CA (US)

(21) Appl. No.: **16/532,065**

(22) Filed: **Aug. 5, 2019**

Related U.S. Application Data

(63) Continuation of application No. 16/226,249, filed on Dec. 19, 2018, which is a continuation of application No. 15/195,199, filed on Jun. 28, 2016.

(60) Provisional application No. 62/188,430, filed on Jul. 2, 2015.

Publication Classification

(51) **Int. Cl.**

| | |
|--------------------|-----------|
| <i>A61B 5/1455</i> | (2006.01) |
| <i>A61B 5/00</i> | (2006.01) |
| <i>A61B 5/145</i> | (2006.01) |
| <i>A61B 5/024</i> | (2006.01) |

(52) **U.S. Cl.**

CPC *A61B 5/14552* (2013.01); *A61B 5/6826* (2013.01); *A61B 5/14532* (2013.01); *A61B 5/742* (2013.01); *A61B 2562/04* (2013.01); *A61B 5/7278* (2013.01); *A61B 5/02416* (2013.01); *A61B 5/14546* (2013.01); *A61B 5/4875* (2013.01); *A61B 5/0002* (2013.01)

(57)

ABSTRACT

A non-invasive, optical-based physiological monitoring system is disclosed. One embodiment includes an emitter configured to emit light. A diffuser is configured to receive and spread the emitted light, and to emit the spread light at a tissue measurement site. The system further includes a concentrator configured to receive the spread light after it has been attenuated by or reflected from the tissue measurement site. The concentrator is also configured to collect and concentrate the received light and to emit the concentrated light to a detector. The detector is configured to detect the concentrated light and to transmit a signal representative of the detected light. A processor is configured to receive the transmitted signal and to determine a physiological parameter, such as, for example, arterial oxygen saturation, in the tissue measurement site.

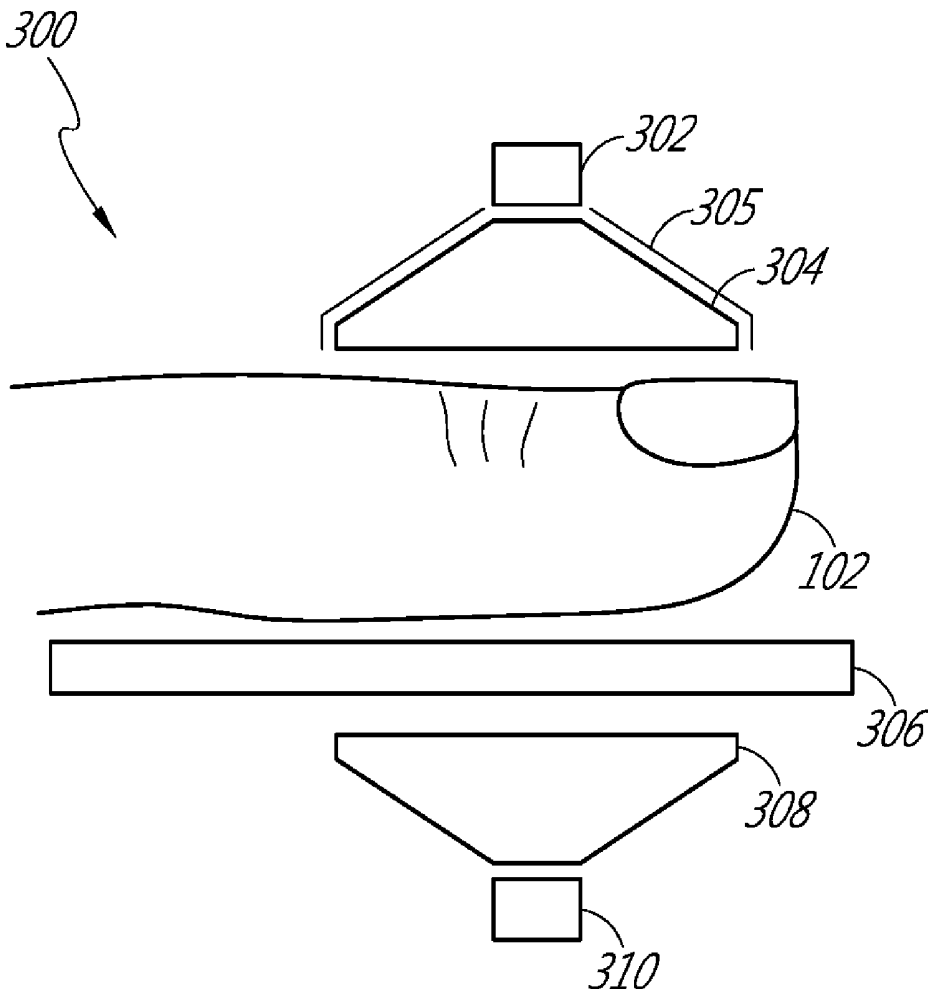

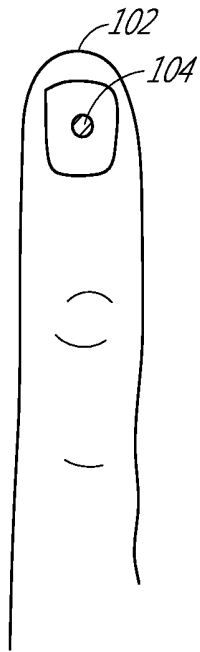

FIG. 1
(PRIOR ART)

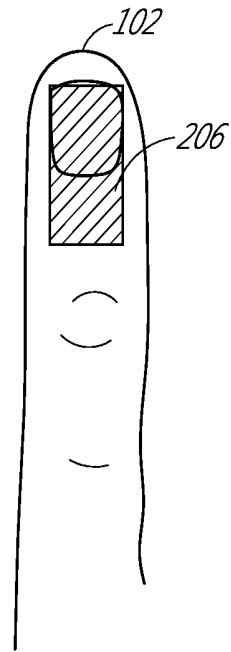

FIG. 2

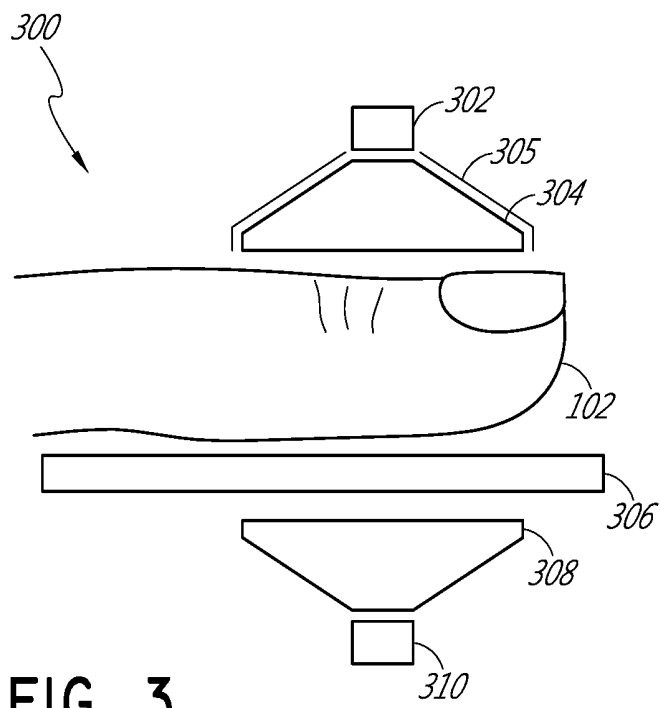

FIG. 3

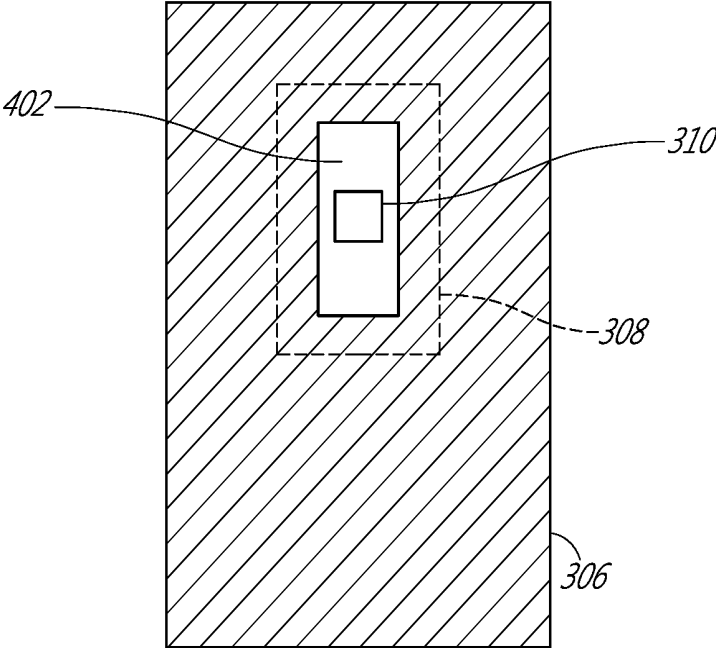

FIG. 4A

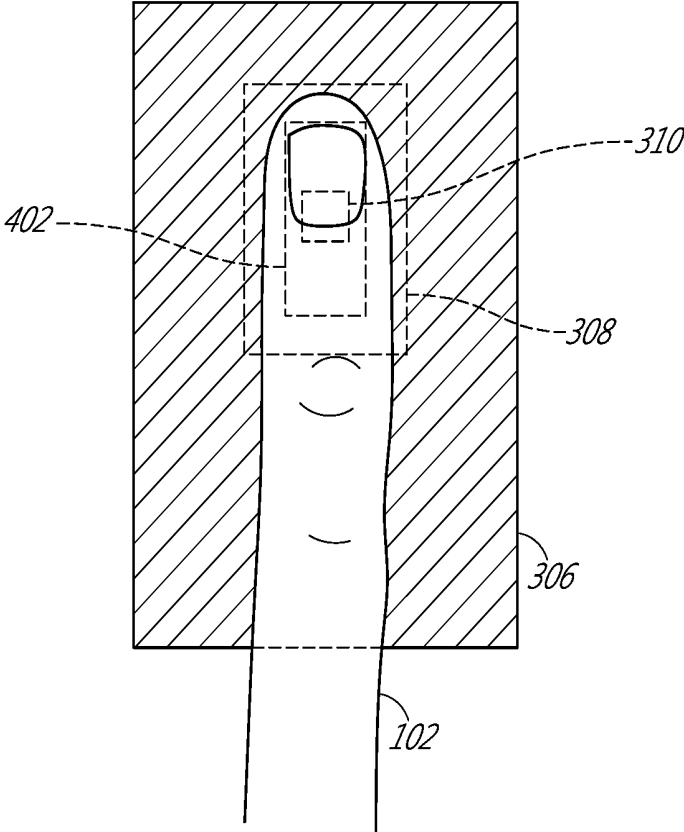

FIG. 4B

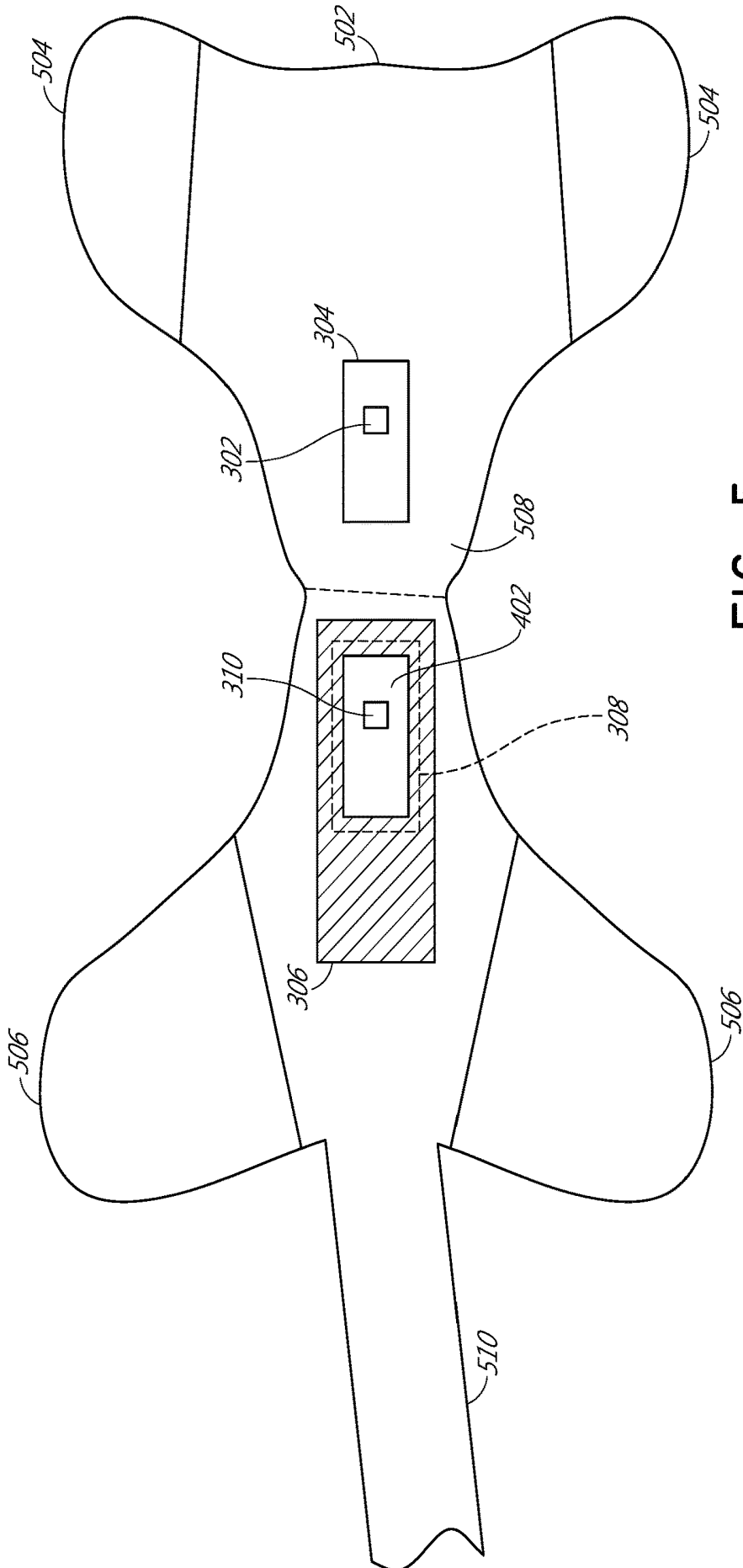

FIG. 5

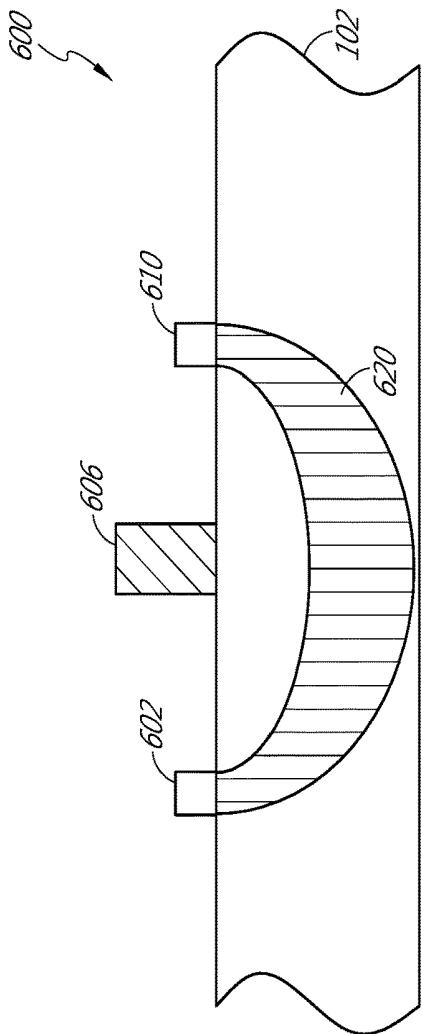

FIG. 6
(PRIOR ART)

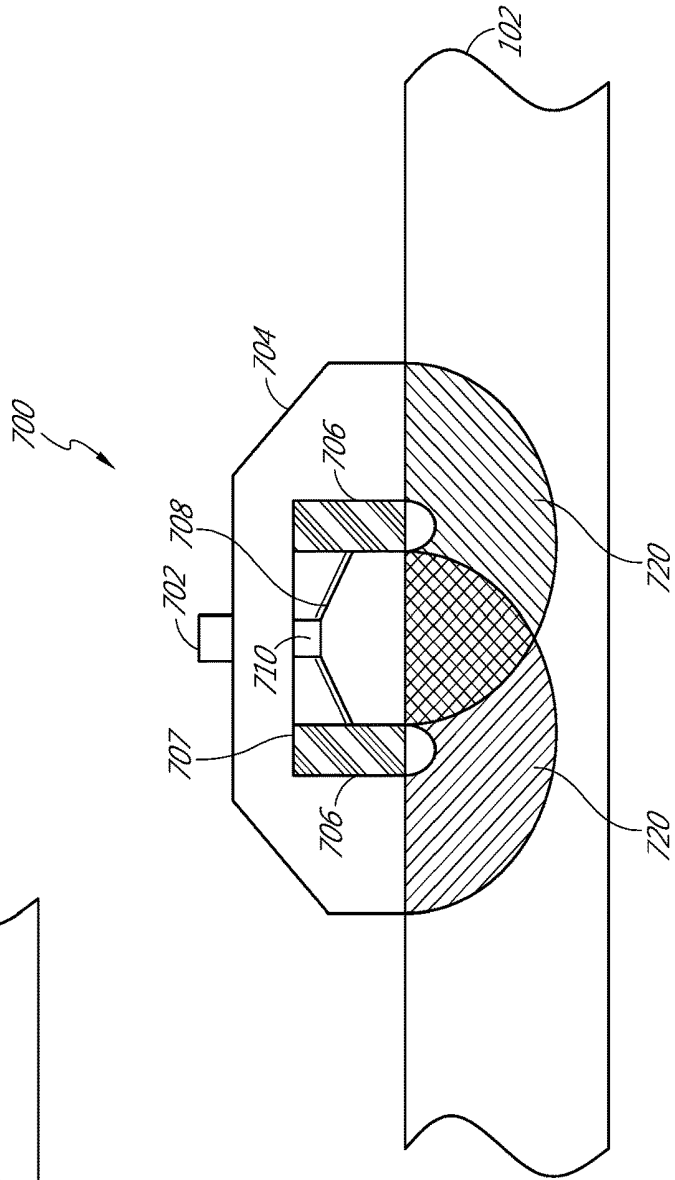

FIG. 7A

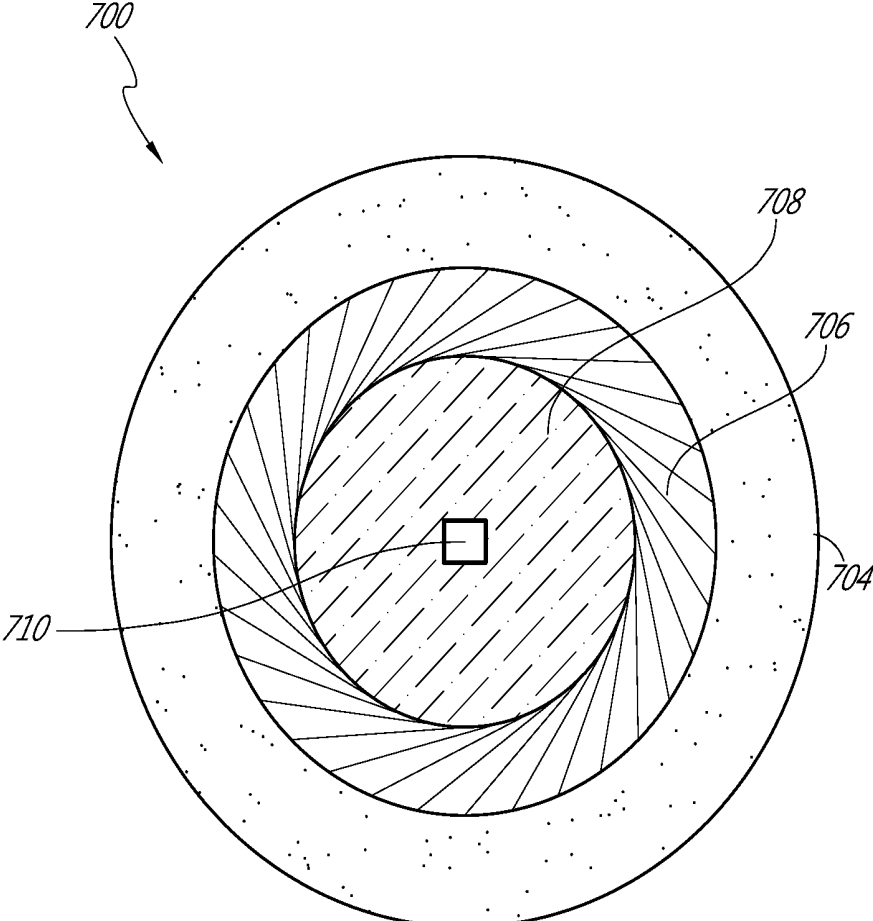

FIG. 7B

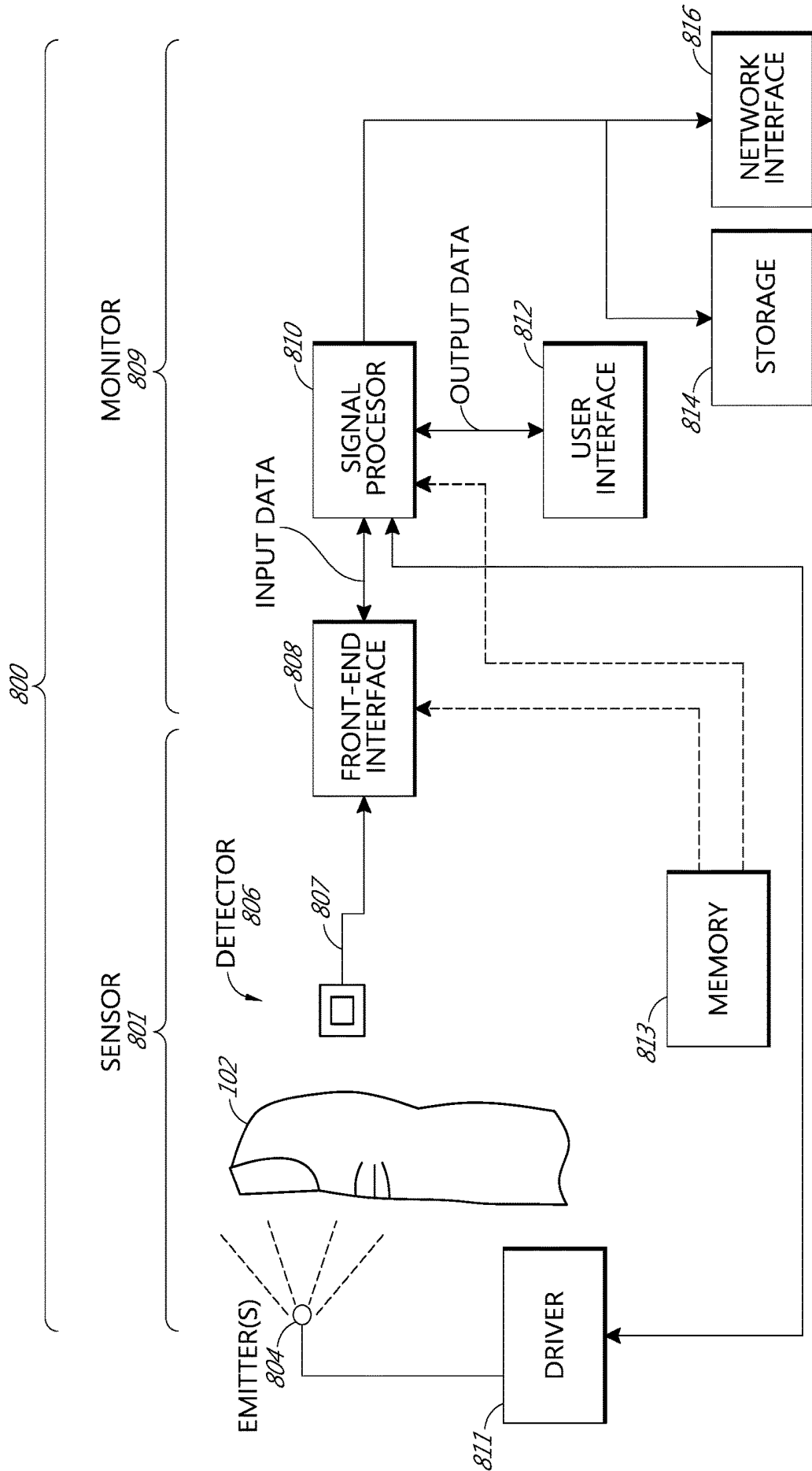

FIG. 8

ADVANCED PULSE OXIMETRY SENSOR

INCORPORATION BY REFERENCE TO ANY PRIORITY APPLICATIONS

[0001] The present application is a continuation of U.S. patent application Ser. No. 16/226,249 filed Dec. 19, 2018, which is a continuation of U.S. patent application Ser. No. 15/195,199 filed Jun. 28, 2016, which claims priority benefit under 35 U.S.C. § 119(e) from U.S. Provisional Application No. 62/188,430, filed Jul. 2, 2015, entitled “Advanced Pulse Oximetry Sensor,” which is incorporated by reference herein. Any and all applications for which a foreign or domestic priority claim is identified in the Application Data Sheet as filed with the present application are hereby incorporated by reference under 37 CFR 1.57.

FIELD OF THE DISCLOSURE

[0002] The present disclosure relates to the field of non-invasive optical-based physiological monitoring sensors, and more particularly to systems, devices and methods for improving the non-invasive measurement accuracy of oxygen saturation, among other physiological parameters.

BACKGROUND

[0003] Spectroscopy is a common technique for measuring the concentration of organic and some inorganic constituents of a solution. The theoretical basis of this technique is the Beer-Lambert law, which states that the concentration c_i of an absorbent in solution can be determined by the intensity of light transmitted through the solution, knowing the pathlength d_λ , the intensity of the incident light $I_{0,\lambda}$, and the extinction coefficient $\epsilon_{i,\lambda}$ at a particular wavelength λ .

[0004] In generalized form, the Beer-Lambert law is expressed as:

$$I_\lambda = I_{0,\lambda} e^{-d_\lambda \cdot \mu_{a,\lambda}} \quad (1)$$

$$\mu_{a,\lambda} = \sum_{i=1}^n \epsilon_{i,\lambda} \cdot c_i \quad (2)$$

where $\mu_{a,\lambda}$ is the bulk absorption coefficient and represents the probability of absorption per unit length. The minimum number of discrete wavelengths that are required to solve equations 1 and 2 is the number of significant absorbers that are present in the solution.

[0005] A practical application of this technique is pulse oximetry, which utilizes a noninvasive sensor to measure oxygen saturation and pulse rate, among other physiological parameters. Pulse oximetry relies on a sensor attached externally to the patient to output signals indicative of various physiological parameters, such as a patient's blood constituents and/or analytes, including for example a percent value for arterial oxygen saturation, among other physiological parameters. The sensor has an emitter that transmits optical radiation of one or more wavelengths into a tissue site and a detector that responds to the intensity of the optical radiation after absorption by pulsatile arterial blood flowing within the tissue site. Based upon this response, a processor determines the relative concentrations of oxygenated hemoglobin (HbO₂) and deoxygenated hemoglobin (Hb) in the

blood so as to derive oxygen saturation, which can provide early detection of potentially hazardous decreases in a patient's oxygen supply.

[0006] A pulse oximetry system generally includes a patient monitor, a communications medium such as a cable, and/or a physiological sensor having one or more light emitters and a detector, such as one or more light-emitting diodes (LEDs) and a photodetector. The sensor is attached to a tissue site, such as a finger, toe, earlobe, nose, hand, foot, or other site having pulsatile blood flow which can be penetrated by light from the one or more emitters. The detector is responsive to the emitted light after attenuation or reflection by pulsatile blood flowing in the tissue site. The detector outputs a detector signal to the monitor over the communication medium. The monitor processes the signal to provide a numerical readout of physiological parameters such as oxygen saturation (SpO₂) and/or pulse rate. A pulse oximetry sensor is described in U.S. Pat. No. 6,088,607 entitled Low Noise Optical Probe; pulse oximetry signal processing is described in U.S. Pat. Nos. 6,650,917 and 6,699,194 entitled Signal Processing Apparatus and Signal Processing Apparatus and Method, respectively; a pulse oximeter monitor is described in U.S. Pat. No. 6,584,336 entitled Universal/Upgrading Pulse Oximeter; all of which are assigned to Masimo Corporation, Irvine, Calif., and each is incorporated by reference herein in its entirety.

[0007] There are many sources of measurement error introduced to pulse oximetry systems. Some such sources of error include the pulse oximetry system's electronic components, including emitters and detectors, as well as chemical and structural physiological differences between patients. Another source of measurement error is the effect of multiple scattering of photons as the photons pass through the patient's tissue (arterial blood) and arrive at the sensor's light detector.

SUMMARY

[0008] This disclosure describes embodiments of non-invasive methods, devices, and systems for measuring blood constituents, analytes, and/or substances such as, by way of non-limiting example, oxygen, carboxyhemoglobin, methemoglobin, total hemoglobin, glucose, proteins, lipids, a percentage thereof (e.g., saturation), pulse rate, perfusion index, oxygen content, total hemoglobin, Oxygen Reserve Index™ (ORI™) or for measuring many other physiologically relevant patient characteristics. These characteristics can relate to, for example, pulse rate, hydration, trending information and analysis, and the like.

[0009] In an embodiment, an optical physiological measurement system includes an emitter configured to emit light of one or more wavelengths. The system also includes a diffuser configured to receive the emitted light, to spread the received light, and to emit the spread light over a larger tissue area than would otherwise be penetrated by the emitter directly emitting light at a tissue measurement site. The tissue measurement site can include, such as, for example, a finger, a wrist, or the like. The system further includes a concentrator configured to receive the spread light after it has been attenuated by or reflected from the tissue measurement site. The concentrator is also configured to collect and concentrate the received light and to emit the concentrated light to a detector. The detector is configured to detect the concentrated light and to transmit a signal indicative of the detected light. The system also includes a

processor configured to receive the transmitted signal indicative of the detected light and to determine, based on an amount of absorption, an analyte of interest, such as, for example, arterial oxygen saturation or other parameter, in the tissue measurement site.

[0010] In certain embodiments of the present disclosure, the diffuser comprises glass, ground glass, glass beads, opal glass, or a microlens-based, band-limited, engineered diffuser that can deliver efficient and uniform illumination. In some embodiments the diffuser is further configured to define a surface area shape by which the emitted spread light is distributed onto a surface of the tissue measurement site. The defined surface area shape can include, by way of non-limiting example, a shape that is substantially rectangular, square, circular, oval, or annular, among others.

[0011] According to some embodiments, the optical physiological measurement system includes an optical filter having a light-absorbing surface that faces the tissue measurement site. The optical filter also has an opening that is configured to allow the spread light, after being attenuated by the tissue measurement site, to be received by the concentrator. In an embodiment, the opening has dimensions, wherein the dimensions of the opening are similar to the defined surface area shape by which the emitted spread light is distributed onto the surface of the tissue measurement site. In an embodiment, the opening has dimensions that are larger than the defined surface area shape by which the emitted spread light is distributed onto the surface of the tissue measurement site. In other embodiments, the dimensions of the opening in the optical filter are not the same as the diffuser opening, but the dimensions are larger than the detector package.

[0012] In other embodiments of the present disclosure, the concentrator comprises glass, ground glass, glass beads, opal glass, or a compound parabolic concentrator. In some embodiments the concentrator comprises a cylindrical structure having a truncated circular conical structure on top. The truncated section is adjacent the detector. The light concentrator is structured to receive the emitted optical radiation, after reflection by the tissue measurement site, and to direct the reflected light to the detector.

[0013] In accordance with certain embodiments of the present disclosure, the processor is configured to determine an average level of the light detected by the detector. The average level of light is used to determine a physiological parameter in the tissue measurement site.

[0014] According to another embodiment, a method to determine a constituent or analyte in a patient's blood is disclosed. The method includes emitting, from an emitter, light of at least one wavelength; spreading, with a diffuser, the emitted light and emitting the spread light from the diffuser to a tissue measurement site; receiving, by a concentrator, the spread light after the spread light has been attenuated by the tissue measurement site; concentrating, by the concentrator, the received light and emitting the concentrated light from the concentrator to a detector; detecting, with the detector, the emitted concentrated light; transmitting, from the detector, a signal responsive to the detected light; receiving, by a processor, the transmitted signal responsive to the detected light; and processing, by the processor, the received signal responsive to the detected light to determine a physiological parameter.

[0015] In some embodiments, the method to determine a constituent or analyte in a patient's blood includes filtering,

with a light-absorbing detector filter, scattered portions of the emitted spread light. According to an embodiment, the light-absorbing detector filter is substantially rectangular in shape and has outer dimensions in the range of approximately 1-5 cm in width and approximately 2-8 cm in length, and has an opening through which emitted light may pass, the opening having dimensions in the range of approximately 0.25-3 cm in width and approximately 1-7 cm in length. In another embodiment, the light-absorbing detector filter is substantially square in shape and has outer dimensions in the range of approximately 0.25-10 cm², and has an opening through which emitted light may pass, the opening having dimensions in the range of approximately 0.1-8 cm². In yet another embodiment, the light-absorbing detector filter is substantially rectangular in shape and has outer dimensions of approximately 3 cm in width and approximately 6 cm in length, and has an opening through which emitted light may pass, the opening having dimensions of approximately 1.5 cm in width and approximately 4 cm in length.

[0016] In still other embodiments of the method to determine a constituent or analyte in a patient's blood, spreading, with a diffuser, the emitted light and emitting the spread light from the diffuser to a tissue measurement site is performed by at least one of a glass diffuser, a ground glass diffuser, a glass bead diffuser, an opal glass diffuser, and an engineered diffuser. In some embodiments the emitted spread light is emitted with a substantially uniform intensity profile. And in some embodiments, emitting the spread light from the diffuser to the tissue measurement site includes spreading the emitted light so as to define a surface area shape by which the emitted spread light is distributed onto a surface of the tissue measurement site.

[0017] According to yet another embodiment, a pulse oximeter is disclosed. The pulse oximeter includes an emitter configured to emit light at one or more wavelengths. The pulse oximeter also includes a diffuser configured to receive the emitted light, to spread the received light, and to emit the spread light directed at a tissue measurement site. The pulse oximeter also includes a detector configured to detect the emitted spread light after being attenuated by or reflected from the tissue measurement site and to transmit a signal indicative of the detected light. The pulse oximeter also includes a processor configured to receive the transmitted signal and to process the received signal to determine an average absorbance of a blood constituent or analyte in the tissue measurement site over a larger measurement site area than can be performed with a point light source or point detector. In some embodiments, the diffuser is further configured to define a surface area shape by which the emitted spread light is distributed onto a surface of the tissue measurement site, and the detector is further configured to have a detection area corresponding to the defined surface area shape by which the emitted spread light is distributed onto the surface of the tissue measurement site. According to some embodiments, the detector comprises an array of detectors configured to cover the detection area. In still other embodiments, the processor is further configured to determine an average of the detected light.

[0018] For purposes of summarizing, certain aspects, advantages and novel features of the disclosure have been described herein. It is to be understood that not necessarily all such advantages can be achieved in accordance with any particular embodiment of the systems, devices and/or meth-

ods disclosed herein. Thus, the subject matter of the disclosure herein can be embodied or carried out in a manner that achieves or optimizes one advantage or group of advantages as taught herein without necessarily achieving other advantages as can be taught or suggested herein.

BRIEF DESCRIPTION OF THE DRAWINGS

[0019] Throughout the drawings, reference numbers can be re-used to indicate correspondence between referenced elements. The drawings are provided to illustrate embodiments of the disclosure described herein and not to limit the scope thereof.

[0020] FIG. 1 illustrates a conventional approach to 2D pulse oximetry in which the emitter is configured to emit optical radiation as a point optical source.

[0021] FIG. 2 illustrates the disclosed 3D approach to pulse oximetry in which the emitted light irradiates a substantially larger volume of tissue as compared to the point source approach described with respect to FIG. 2A.

[0022] FIG. 3 illustrates schematically a side view of a 3D pulse oximetry sensor according to an embodiment of the present disclosure.

[0023] FIG. 4A is a top view of a portion of a 3D pulse oximetry sensor according to an embodiment of the present disclosure.

[0024] FIG. 4B illustrates the top view of a portion of the 3D pulse oximetry sensor shown in FIG. 4A, with the addition of a tissue measurement site in operational position.

[0025] FIG. 5 illustrates a top view of a 3D pulse oximetry sensor according to an embodiment of the present disclosure.

[0026] FIG. 6 illustrates a conventional 2D approach to reflective pulse oximetry in which the emitter is configured to emit optical radiation as a point optical source.

[0027] FIG. 7A is a simplified schematic side view illustration of a reflective 3D pulse oximetry sensor according to an embodiment of the present disclosure.

[0028] FIG. 7B is a simplified schematic top view illustration of the 3D reflective pulse oximetry sensor of FIG. 7A.

[0029] FIG. 8 illustrates a block diagram of an example pulse oximetry system capable of noninvasively measuring one or more blood analytes in a monitored patient, according to an embodiment of the disclosure.

DETAILED DESCRIPTION

[0030] FIG. 1 illustrates schematically a conventional pulse oximetry sensor having a two-dimensional (2D) approach to pulse oximetry. As illustrated, the emitter 104 is configured to emit optical radiation as a point optical source, i.e., an optical radiation source that has negligible dimensions such that it may be considered as a point. This approach is referred to herein as “two-dimensional” pulse oximetry because it applies a two-dimensional analytical model to the three-dimensional space of the tissue measurement site 102 of the patient. Point optical sources feature a defined, freely selectable, and homogeneous light beam area. Light beams emitted from LED point sources often exhibit a strong focus which can produce a usually sharply-defined and evenly-lit illuminated spot often with high intensity dynamics. Illustratively, when looking at the surface of the tissue measurement site 102 (or “sample tissue”), which in this example is a finger, a small point-like surface

area of tissue 204 is irradiated by a point optical source. In some embodiments, the irradiated circular area of the point optical source is in the range between 8 and 150 microns. Illustratively, the emitted point optical source of light enters the tissue measurement site 102 as a point of light. As the light penetrates the depth of the tissue 102, it does so as a line or vector, representing a two-dimensional construct within a three-dimensional structure, namely the patient's tissue 102.

[0031] Use of a point optical source is believed to reduce variability in light pathlength which would lead to more accurate oximetry measurements. However, in practice, photons do not travel in straight paths. Instead, the light particles scatter, bouncing around between various irregular objects (such as, for example, red blood cells) in the patient's blood. Accordingly, photon pathlengths vary depending on, among other things, their particular journeys through and around the tissue at the measurement site 102. This phenomenon is referred to as “multiple scattering.” In a study, the effects of multiple scattering were examined by comparing the results of photon diffusion analysis with those obtained using an analysis based on the Beer-Lambert law, which neglects multiple scattering in the determination of light pathlength. The study found that that the difference between the average lengths of the paths traveled by red and infrared photons makes the oximeter's calibration curve (based on measurements obtained from normal subjects) sensitive to the total attenuation coefficients of the tissue in the two wavelength bands used for pulse oximetry, as well as to absorption by the pulsating arterial blood.

[0032] FIG. 2 illustrates schematically the disclosed systems, devices, and methods to implement three-dimensional (3D) pulse oximetry in which the emitted light irradiates a larger volume of tissue at the measurement site 102 as compared to the 2D point optical source approach described with respect to FIG. 1. In an embodiment, again looking at the surface of the tissue measurement site 102, the irradiated surface area 206 of the measurement site 102 is substantially rectangular in shape with dimensions in the range of approximately 0.25-3 cm in width and approximately 1-6 cm in length. In another embodiment, the irradiated surface area 206 of the measurement site 102 is substantially rectangular in shape and has dimensions of approximately 1.5 cm in width and approximately 2 cm in length. In another embodiment, the irradiated surface area 206 of the measurement site 102 is substantially rectangular in shape and has dimensions of approximately 0.5 cm in width and approximately 1 cm in length. In another embodiment, the irradiated surface area 206 of the measurement site 102 is substantially rectangular in shape has dimensions of approximately 1 cm in width and approximately 1.5 cm in length. In yet another embodiment, the irradiated surface area 206 of the measurement site 102 is substantially square in shape and has dimensions in a range of approximately 0.25-9 cm². In certain embodiments, the irradiated surface area 206 of the measurement site 102 is within a range of approximately 0.5-2 cm in width, and approximately 1-4 cm in length. Of course a skilled artisan will appreciate that many other shapes and dimensions of irradiated surface area 206 can be used. Advantageously, by irradiating the tissue measurement site 102 with a surface area 206, the presently disclosed systems, devices, and methods apply a three-dimensional analytical model to the three-dimensional structure being measured, namely, the patient's sample tissue 102.

[0033] According to the Beer-Lambert law, the amount of light absorbed by a substance is proportional to the concentration of the light-absorbing substance in the irradiated solution (i.e., arterial blood). Advantageously, by irradiating a larger volume of tissue 102, a larger sample size of light attenuated (or reflected) by the tissue 102 is measured. The larger, 3D sample provides a data set that is more representative of the complete interaction of the emitted light as it passes through the patient's blood as compared to the 2D point source approach described above with respect to FIG. 1. By taking an average of the detected light, as detected over a surface area substantially larger than a single point, the disclosed pulse oximetry systems, devices, and methods will yield a more accurate measurement of the emitted light absorbed by the tissue, which will lead to a more accurate oxygen saturation measurement.

[0034] FIG. 3 illustrates schematically a side view of a pulse oximetry 3D sensor 300 according to an embodiment of the present disclosure. In the illustrated embodiment, the 3D sensor 300 irradiates the tissue measurement site 102 and detects the emitted light, after being attenuated by the tissue measurement site 102. In other embodiments, for example, as describe below with respect to FIGS. 7A and 7B, the 3D sensor 300 can be arranged to detect light that is reflected by the tissue measurement site 102. The 3D sensor 300 includes an emitter 302, a light diffuser 304, a light-absorbing detector filter 306, a light concentrator 308, and a detector 310. In some optional embodiments, the 3D sensor 300 further includes a reflector 305. The reflector 305 can be a metallic reflector or other type of reflector. Reflector 305 can be a coating, film, layer or other type of reflector. The reflector 305 can serve as a reflector to prevent emitted light from emitting out of a top portion of the light diffuser 304 such that light from the emitter 302 is directed in the tissue rather than escaping out of a side or top of the light diffuser 304. Additionally, the reflector 305 can prevent ambient light from entering the diffuser 304 which might ultimately cause errors within the detected light. The reflector 305 also prevent light piping that might occur if light from the detector 302 is able to escape from the light diffuser 304 and be piped around a sensor securement mechanism to detector 310 without passing through the patient's tissue 102.

[0035] The emitter 302 can serve as the source of optical radiation transmitted towards the tissue measurement site 102. The emitter 302 can include one or more sources of optical radiation, such as LEDs, laser diodes, incandescent bulbs with appropriate frequency-selective filters, combinations of the same, or the like. In an embodiment, the emitter 302 includes sets of optical sources that are capable of emitting visible and near-infrared optical radiation. In some embodiments, the emitter 302 transmits optical radiation of red and infrared wavelengths, at approximately 650 nm and approximately 940 nm, respectively. In some embodiments, the emitter 302 includes a single source optical radiation.

[0036] The light diffuser 304 receives the optical radiation emitted from the emitter 302 and spreads the optical radiation over an area, such as the area 206 depicted in FIG. 2. In some embodiments, the light diffuser 304 is a beam shaper that can homogenize the input light beam from the emitter 302, shape the output intensity profile of the received light, and define the way (e.g., the shape or pattern) the emitted light is distributed to the tissue measurement site 102. Examples of materials that can be used to realize the light diffuser 304 include, without limitation, a white sur-

face, glass, ground glass, glass beads, polytetrafluoroethylene (also known as Teflon®, opal glass, and greyed glass, to name a few. Additionally, engineered diffusers can be used to realize the diffuser 304 by providing customized light shaping with respect to intensity and distribution. Such diffusers can, for example, deliver substantially uniform illumination over a specified target area (such as, for example, irradiated surface area 206) in an energy-efficient manner. Examples of engineered diffusers can include molded plastics with specific shapes, patterns or textures designed to diffuse the emitter light across the entirety of the patient's tissue surface.

[0037] Advantageously, the diffuser 304 can receive emitted light in the form of a point optical source and spread the light to fit a desired surface area on a plane defined by the surface of the tissue measurement site 102. In an embodiment, the diffuser 304 is made of ground glass which spreads the emitted light with a Gaussian intensity profile. In another embodiment the diffuser 304 includes glass beads. In some embodiments, the diffuser 304 is constructed so as to diffuse the emitted light in a Lambertian pattern. A Lambertian pattern is one in which the radiation intensity is substantially constant throughout the area of dispersion. One such diffuser 304 is made from opal glass. Opal glass is similar to ground glass, but has one surface coated with a milky white coating to diffuse light evenly. In an embodiment, the diffuser 304 is capable of distributing the emitted light on the surface of a plane (e.g., the surface of the tissue measurement site 102) in a predefined geometry (e.g., a rectangle, square, or circle), and with a substantially uniform intensity profile and energy distribution. In some embodiments, the efficiency, or the amount of light transmitted by the diffuser 304, is greater than 70% of the light emitted by the emitter 302. In some embodiments, the efficiency is greater than 90% of the emitted light. Other optical elements known in the art may be used for the diffuser 304.

[0038] In an embodiment, the diffuser 304 has a substantially rectangular shape having dimensions within a range of approximately 0.5-2 cm in width and approximately 1-4 centimeters in length. In another embodiment, the substantially rectangular shape of the diffuser 304 has dimensions of approximately 0.5 cm in width and approximately 1 cm in length. In another embodiment, the diffuser's 304 substantially rectangular shape has dimensions of approximately 1 cm in width and approximately 1.5 cm in length. In yet another embodiment, the diffuser 304 has a substantially square shape with dimensions in the range of approximately 0.25-10 cm².

[0039] The light-absorbing detector filter 306, which is also depicted in FIG. 4A in a top view, is a planar surface having an opening 402 through which the emitted light may pass after being attenuated by the tissue measurement site 102. In the depicted embodiment, the opening 402 is rectangular-shaped, with dimensions substantially similar to the irradiated surface area 206. According to an embodiment, the light-absorbing detector filter is substantially rectangular in shape and has outer dimensions of 4 cm in width and 8 cm in length, and has an opening through which emitted light may pass, the opening having dimensions of 2 cm in width and 5 cm in length. In another embodiment, the light-absorbing detector filter is substantially rectangular in shape and has outer dimensions in the range of 1-3 cm in width and 2-8 cm in length, and has an opening through which emitted light may pass, the opening having dimensions in the range

of 0.25-2 cm in width and 1-4 cm in length. In yet another embodiment, the light-absorbing detector filter is substantially rectangular in shape and has outer dimensions of 3 cm in width and 6 cm in length, and has an opening through which emitted light may pass, the opening having dimensions of 1.5 cm in width and 4 cm in length.

[0040] The top surface of the light-absorbing filter 306 (facing the tissue measurement site 102 and the emitter 302) is coated with a material that absorbs light, such as, for example, black pigment. Many other types of light-absorbing materials are well known in the art and can be used with the detector filter 306. During operation, light emitted from the emitter 302 can reflect off of the tissue measurement site 102 (or other structures within the 3D sensor 300) to neighboring portions of the 3D sensor 300. If those neighboring portions of the 3D sensor 300 possess reflective surfaces, then the light can reflect back to the tissue measurement site 102, progress through the tissue and arrive at the detector 310. Such multiple scattering can result in detecting photons whose pathlengths are considerably longer than most of the light that is detected, thereby introducing variations in pathlength which will affect the accuracy of the measurements of the pulse oximetry 3D sensor 300. Advantageously, the light-absorbing filter 306 reduces or eliminates the amount of emitted light that is reflected in this manner because it absorbs such reflected light, thereby stopping the chain of scattering events. In certain embodiments, the sensor-facing surfaces of other portions of the 3D sensor 300 are covered in light-absorbing material to further decrease the effect of reflective multiple scattering.

[0041] The light concentrator 308 is a structure to receive the emitted optical radiation, after attenuation by the tissue measurement site 102, to collect and concentrate the dispersed optical radiation, and to direct the collected and concentrated optical radiation to the detector 310. In an embodiment, the light concentrator 308 is made of ground glass or glass beads. In some embodiments, the light concentrator 308 includes a compound parabolic concentrator.

[0042] As described above with respect to FIG. 1, the detector 310 captures and measures light from the tissue measurement site 102. For example, the detector 310 can capture and measure light transmitted from the emitter 302 that has been attenuated by the tissue in the measurement site 102. The detector 310 can output a detector signal responsive to the light captured or measured. The detector 310 can be implemented using one or more photodiodes, phototransistors, or the like. In addition, a plurality of detectors 310 can be arranged in an array with a spatial configuration corresponding to the irradiated surface area 206 to capture the attenuated or reflected light from the tissue measurement site.

[0043] Referring to FIG. 4A, a top view of a portion of the 3D sensor 300 is provided. The light-absorbing detector filter 306 is illustrated having a top surface coated with a light-absorbing material. The light-absorbing material can be a black opaque material or coating or any other dark color or coating configured to absorb light. Additionally, a rectangular opening 402 is positioned relative to the light concentrator 308 (shown in phantom) and the detector 310 such that light may pass through the rectangular opening 402, into the light concentrator 308, and to the detector 310. FIG. 4B illustrates the top view of a portion of the 3D sensor 300 as in FIG. 4A, with the addition of the tissue measurement site 102 in operational position. Accordingly, the

rectangular opening 402, the light concentrator 308 and the detector 310 are shown in phantom as being under the tissue measurement site 102. In FIGS. 4A and 4B, the light concentrator 308 is shown to have dimensions significantly larger than the dimensions of the rectangular opening 402. In other embodiments, the dimensions of the light concentrator 308, the rectangular opening 402, and the irradiated surface area 206 are substantially similar.

[0044] FIG. 5 illustrates a top view of a 3D pulse oximetry sensor 500 according to an embodiment of the present disclosure. The 3D sensor 500 is configured to be worn on a patient's finger 102. The 3D sensor 500 includes an adhesive substrate 502 having front flaps 504 and rear flaps 506 extending outward from a center portion 508 of the 3D sensor 500. The center portion 508 includes components of the 3D pulse oximetry sensor 300 described with respect to FIGS. 3, 4A and 4B. On the front side of the adhesive substrate 502 the emitter 302 and the light diffuser 304 are positioned. On the rear side of the adhesive substrate 502 the light-absorbent detector filter 306, the light concentrator 308 and the detector 310 are positioned. In use, the patient's finger serving as the tissue measurement site 102 is positioned over the rectangular opening 402 such that when the front portion of the adhesive substrate is folded over on top of the patient's finger 102, the emitter 302 and the light diffuser 304 are aligned with the measurement site 102, the filter 306, the light concentrator 308 and the detector 310. Once alignment is established, the front and rear flaps 504, 506 can be wrapped around the finger measurement site 102 such that the adhesive substrate 502 provides a secure contact between the patient's skin and the 3D sensor 500. FIG. 5 also illustrates an example of a sensor connector cable 510 which is used to connect the 3D sensor 500 to a monitor 809, as described with respect to FIG. 8.

[0045] FIG. 6 is a simplified schematic illustration of a conventional, 2D approach to reflective pulse oximetry in which the emitter is configured to emit optical radiation as a point optical source. Reflective pulse oximetry is a method by which the emitter and detector are located on the same side of the tissue measurement site 102. Light is emitted into a tissue measurement site 102 and attenuated. The emitted light passes into the tissue 102 and is then reflected back to the same side of the tissue measurement site 102 as the emitter. As illustrated in FIG. 6, a depicted reflective 2D pulse oximetry sensor 600 includes an emitter 602, a light block 606, and a detector 610. The light block 606 is necessary because the emitter 602 and the detector 610 are located on the same side of the tissue measurement site 102. Accordingly, the light block 606 prevents incident emitter light, which did not enter the tissue measurement site 102, from arriving at the detector 610. The depicted 2D pulse oximetry sensor 600 is configured to emit light as a point source. As depicted in FIG. 6, a simplified illustration of the light path 620 of the emitted light from the emitter 602, through the tissue measurement site 102, and to the detector 610 is provided. Notably, a point source of light is emitted, and a point source of light is detected. As discussed above with respect to FIG. 1, use of a point optical source can result in substantial measurement error due to pathlength variability resulting from the multiple scatter phenomenon. The sample space provided by a 2D point optical emitter source is not large enough to account for pathlength variability, which will skew measurement results.

[0046] FIGS. 7A and 7B are simplified schematic side and top views, respectively, of a 3D reflective pulse oximetry sensor 700 according to an embodiment of the present disclosure. In the illustrated embodiment, the 3D sensor 700 irradiates the tissue measurement site 102 and detects the emitted light that is reflected by the tissue measurement site 102. The 3D sensor 700 can be placed on a portion of the patient's body that has relatively flat surface, such as, for example a wrist, because the emitter 702 and detector 710 are on located the same side of the tissue measurement site 102. The 3D sensor 700 includes an emitter 702, a light diffuser 704, a light block 706, a light concentrator 708, and a detector 710.

[0047] As previously described, the emitter 702 can serve as the source of optical radiation transmitted towards the tissue measurement site 102. The emitter 702 can include one or more sources of optical radiation. Such sources of optical radiation can include LEDs, laser diodes, incandescent bulbs with appropriate frequency-selective filters, combinations of the same, or the like. In an embodiment, the emitter 702 includes sets of optical sources that are capable of emitting visible and near-infrared optical radiation. In some embodiments, the emitter 702 transmits optical radiation of red and infrared wavelengths, at approximately 650 nm and approximately 940 nm, respectively. In some embodiments, the emitter 702 includes a single source of optical radiation.

[0048] The light diffuser 704 receives the optical radiation emitted from the emitter 302 and homogenously spreads the optical radiation over a wide, donut-shaped area, such as the area outlined by the light diffuser 704 as depicted in FIG. 7B. Advantageously, the diffuser 704 can receive emitted light in the form of a 2D point optical source (or any other form) and spread the light to fit the desired surface area on a plane defined by the surface of the tissue measurement site 102. In an embodiment, the diffuser 704 is made of ground glass or glass beads. A skilled artisan will understand that many other materials can be used to make the light diffuser 704.

[0049] The light blocker 706 includes an annular ring having a cover portion 707 sized and shaped to form a light isolation chamber for the light concentrator 708 and the detector 710. (For purposes of illustration, the light block cover 707 is not illustrated in FIG. 7B.) The light blocker 706 and the cover 707 can be made of any material that optically isolates the light concentrator 708 and the detector 710. The light isolation chamber formed by the light blocker 706 and cover 708 ensures that the only light detected by the detector 710 is light that is reflected from the tissue measurement site.

[0050] The light concentrator 708 is a cylindrical structure with a truncated circular conical structure on top, the truncated section of which is adjacent the detector 710. The light concentrator 708 is structured to receive the emitted optical radiation, after reflection by the tissue measurement site 102, and to direct the reflected light to the detector 710. In an embodiment, the light concentrator 708 is made of ground glass or glass beads. In some embodiments, the light concentrator 708 includes a compound parabolic concentrator.

[0051] As previously described, the detector 710 captures and measures light from the tissue measurement site 102. For example, the detector 710 can capture and measure light transmitted from the emitter 702 that has been reflected from

the tissue in the measurement site 102. The detector 710 can output a detector signal responsive to the light captured or measured. The detector 710 can be implemented using one or more photodiodes, phototransistors, or the like. In addition, a plurality of detectors 710 can be arranged in an array with a spatial configuration corresponding to the irradiated surface area depicted in FIG. 7B by the light concentrator 708 to capture the reflected light from the tissue measurement site.

[0052] Advantageously, the light path 720 illustrated in FIG. 7A depicts a substantial sample of reflected light that enter the light isolation chamber formed by the light blocker 706 and cover 707. As previously discussed, the large sample of reflected light (as compared to the reflected light collected using the 2D point optical source approach) provides the opportunity to take an average of the detected light, to derive a more accurate measurement of the emitted light absorbed by the tissue, which will lead to a more accurate oxygen saturation measurement.

[0053] Referring now to FIG. 7B, a top view of the 3D sensor 700 is illustrated with both the emitter 702 and the light blocker cover 707 removed for ease of illustration. The outer ring illustrates the footprint of the light diffuser 704. As light is emitted from the emitter 702 (not shown in FIG. 7B), it is diffused homogenously and directed to the tissue measurement site 102. The light blocker 706 forms the circular wall of a light isolation chamber to keep incident light from being sensed by the detector 710. The light blocker cover 707 blocks incidental light from entering the light isolation chamber from above. The light concentrator 710 collects the reflected light from the tissue measurement site 102 and funnels it upward toward the detector 710 at the center of the 3D sensor 700.

[0054] FIG. 8 illustrates an example of an optical physiological measurement system 800, which may also be referred to herein as a pulse oximetry system 800. In certain embodiments, the pulse oximetry system 800 noninvasively measures a blood analyte, such as oxygen, carboxyhemoglobin, methemoglobin, total hemoglobin, glucose, proteins, lipids, a percentage thereof (e.g., saturation), pulse rate, perfusion index, oxygen content, total hemoglobin, Oxygen Reserve Index™ (ORI™) or many other physiologically relevant patient characteristics. These characteristics can relate to, for example, pulse rate, hydration, trending information and analysis, and the like. The system 800 can also measure additional blood analytes and/or other physiological parameters useful in determining a state or trend of wellness of a patient.

[0055] The pulse oximetry system 800 can measure analyte concentrations at least in part by detecting optical radiation attenuated by tissue at a measurement site 102. The measurement site 102 can be any location on a patient's body, such as a finger, foot, earlobe, wrist, forehead, or the like.

[0056] The pulse oximetry system 800 can include a sensor 801 (or multiple sensors) that is coupled to a processing device or physiological monitor 809. In an embodiment, the sensor 801 and the monitor 809 are integrated together into a single unit. In another embodiment, the sensor 801 and the monitor 809 are separate from each other and communicate with one another in any suitable manner, such as via a wired or wireless connection. The sensor 801 and monitor 809 can be attachable and detachable from each

other for the convenience of the user or caregiver, for ease of storage, sterility issues, or the like.

[0057] In the depicted embodiment shown in FIG. 8, the sensor 801 includes an emitter 804, a detector 806, and a front-end interface 808. The emitter 804 can serve as the source of optical radiation transmitted towards measurement site 102. The emitter 804 can include one or more sources of optical radiation, such as light emitting diodes (LEDs), laser diodes, incandescent bulbs with appropriate frequency-selective filters, combinations of the same, or the like. In an embodiment, the emitter 804 includes sets of optical sources that are capable of emitting visible and near-infrared optical radiation.

[0058] The pulse oximetry system 800 also includes a driver 811 that drives the emitter 804. The driver 811 can be a circuit or the like that is controlled by the monitor 809. For example, the driver 811 can provide pulses of current to the emitter 804. In an embodiment, the driver 811 drives the emitter 804 in a progressive fashion, such as in an alternating manner. The driver 811 can drive the emitter 804 with a series of pulses for some wavelengths that can penetrate tissue relatively well and for other wavelengths that tend to be significantly absorbed in tissue. A wide variety of other driving powers and driving methodologies can be used in various embodiments. The driver 811 can be synchronized with other parts of the sensor 801 to minimize or reduce jitter in the timing of pulses of optical radiation emitted from the emitter 804. In some embodiments, the driver 811 is capable of driving the emitter 804 to emit optical radiation in a pattern that varies by less than about 10 parts-per-million.

[0059] The detector 806 captures and measures light from the tissue measurement site 102. For example, the detector 806 can capture and measure light transmitted from the emitter 804 that has been attenuated or reflected from the tissue at the measurement site 102. The detector 806 can output a detector signal 107 responsive to the light captured and measured. The detector 806 can be implemented using one or more photodiodes, phototransistors, or the like. In some embodiments, a detector 806 is implemented in detector package to capture and measure light from the tissue measurement site 102 of the patient. The detector package can include a photodiode chip mounted to leads and enclosed in an encapsulant. In some embodiments, the dimensions of the detector package are approximately 2 square centimeters. In other embodiments, the dimensions of the detector package are approximately 1.5 centimeters in width and approximately 2 centimeters in length.

[0060] The front-end interface 808 provides an interface that adapts the output of the detectors 806, which is responsive to desired physiological parameters. For example, the front-end interface 808 can adapt the signal 807 received from the detector 806 into a form that can be processed by the monitor 809, for example, by a signal processor 810 in the monitor 809. The front-end interface 808 can have its components assembled in the sensor 801, in the monitor 809, in a connecting cabling (if used), in combinations of the same, or the like. The location of the front-end interface 808 can be chosen based on various factors including space desired for components, desired noise reductions or limits, desired heat reductions or limits, and the like.

[0061] The front-end interface 808 can be coupled to the detector 806 and to the signal processor 810 using a bus, wire, electrical or optical cable, flex circuit, or some other

form of signal connection. The front-end interface 808 can also be at least partially integrated with various components, such as the detectors 806. For example, the front-end interface 808 can include one or more integrated circuits that are on the same circuit board as the detector 806. Other configurations can also be used.

[0062] As shown in FIG. 8, the monitor 909 can include the signal processor 810 and a user interface, such as a display 812. The monitor 809 can also include optional outputs alone or in combination with the display 812, such as a storage device 814 and a network interface 816. In an embodiment, the signal processor 810 includes processing logic that determines measurements for desired analytes based on the signals received from the detector 806. The signal processor 810 can be implemented using one or more microprocessors or sub-processors (e.g., cores), digital signal processors, application specific integrated circuits (ASICs), field programmable gate arrays (FPGAs), combinations of the same, and the like.

[0063] The signal processor 810 can provide various signals that control the operation of the sensor 801. For example, the signal processor 810 can provide an emitter control signal to the driver 811. This control signal can be useful in order to synchronize, minimize, or reduce jitter in the timing of pulses emitted from the emitter 804. Accordingly, this control signal can be useful in order to cause optical radiation pulses emitted from the emitter 804 to follow a precise timing and consistent pattern. For example, when a transimpedance-based front-end interface 808 is used, the control signal from the signal processor 810 can provide synchronization with an analog-to-digital converter (ADC) in order to avoid aliasing, cross-talk, and the like. As also shown, an optional memory 813 can be included in the front-end interface 808 and/or in the signal processor 810. This memory 813 can serve as a buffer or storage location for the front-end interface 808 and/or the signal processor 810, among other uses.

[0064] The user interface 812 can provide an output, e.g., on a display, for presentation to a user of the pulse oximetry system 800. The user interface 812 can be implemented as a touch-screen display, a liquid crystal display (LCD), an organic LED display, or the like. In alternative embodiments, the pulse oximetry system 800 can be provided without a user interface 812 and can simply provide an output signal to a separate display or system.

[0065] The storage device 814 and a network interface 816 represent other optional output connections that can be included in the monitor 809. The storage device 814 can include any computer-readable medium, such as a memory device, hard disk storage, EEPROM, flash drive, or the like. The various software and/or firmware applications can be stored in the storage device 814, which can be executed by the signal processor 810 or another processor of the monitor 809. The network interface 816 can be a serial bus port (RS-232/RS-485), a Universal Serial Bus (USB) port, an Ethernet port, a wireless interface (e.g., WiFi such as any 802.1x interface, including an internal wireless card), or other suitable communication device(s) that allows the monitor 809 to communicate and share data with other devices. The monitor 809 can also include various other components not shown, such as a microprocessor, graphics processor, or controller to output the user interface 812, to control data communications, to compute data trending, or to perform other operations.

[0066] Although not shown in the depicted embodiment, the pulse oximetry system 800 can include various other components or can be configured in different ways. For example, the sensor 801 can have both the emitter 804 and detector 806 on the same side of the tissue measurement site 102 and use reflectance to measure analytes.

[0067] Although the foregoing disclosure has been described in terms of certain preferred embodiments, many other variations than those described herein will be apparent to those of ordinary skill in the art.

[0068] Conditional language used herein, such as, among others, “can,” “might,” “may,” “e.g.,” and the like, unless specifically stated otherwise, or otherwise understood within the context as used, is generally intended to convey that certain embodiments include, while other embodiments do not include, certain features, elements and/or states. Thus, such conditional language is not generally intended to imply that features, elements and/or states are in any way required for one or more embodiments or that one or more embodiments necessarily include logic for deciding, with or without author input or prompting, whether these features, elements and/or states are included or are to be performed in any particular embodiment. The terms “comprising,” “including,” “having,” and the like are synonymous and are used inclusively, in an open-ended fashion, and do not exclude additional elements, features, acts, operations, and so forth. Also, the term “or” is used in its inclusive sense (and not in its exclusive sense) so that when used, for example, to connect a list of elements, the term “or” means one, some, or all of the elements in the list. Further, the term “each,” as used herein, in addition to having its ordinary meaning, can mean any subset of a set of elements to which the term “each” is applied.

[0069] While the above detailed description has shown, described, and pointed out novel features as applied to various embodiments, it will be understood that various omissions, substitutions, and changes in the form and details of the systems, devices or algorithms illustrated can be made without departing from the spirit of the disclosure. As will be recognized, certain embodiments of the disclosure described herein can be embodied within a form that does not provide all of the features and benefits set forth herein, as some features can be used or practiced separately from others.

[0070] The term “and/or” herein has its broadest, least limiting meaning which is the disclosure includes A alone, B alone, both A and B together, or A or B alternatively, but does not require both A and B or require one of A or one of B. As used herein, the phrase “at least one of” A, B, “and” C should be construed to mean a logical A or B or C, using a non-exclusive logical or.

[0071] The apparatuses and methods described herein may be implemented by one or more computer programs executed by one or more processors. The computer programs include processor-executable instructions that are stored on a non-transitory tangible computer readable medium. The computer programs may also include stored data. Non-limiting examples of the non-transitory tangible computer readable medium are nonvolatile memory, magnetic storage, and optical storage. Although the foregoing disclosure has been described in terms of certain preferred embodiments, other embodiments will be apparent to those of ordinary skill in the art from the disclosure herein. Additionally, other combinations, omissions, substitutions

and modifications will be apparent to the skilled artisan in view of the disclosure herein. Accordingly, the present invention is not intended to be limited by the description of the preferred embodiments, but is to be defined by reference to claims.

[0072] Additionally, all publications, patents, and patent applications mentioned in this specification are herein incorporated by reference to the same extent as if each individual publication, patent, or patent application were specifically and individually indicated to be incorporated by reference.

1. (canceled)
2. A physiological monitoring device comprising:
 - a plurality of emitters, wherein each of the plurality of emitters is configured to emit light proximate a wrist of a user;
 - a material positioned between the plurality of emitters and the tissue measurement site, the material configured to alter a shape of the light emitted from one or more of the plurality of emitters before the light reaches the tissue measurement site;
 - a plurality of detectors configured to detect the light after attenuation by tissue, the plurality of detectors further configured to output at least one signal responsive to the detected light;
 - a surface comprising a dark-colored coating, the surface positioned between the plurality of detectors and the tissue, the dark-colored coating comprising an opening configured to allow at least a portion of light reflected from the tissue to pass through the surface;
 - a light block between the plurality of emitters and the plurality of detectors and configured to prevent at least a portion of the light emitted from the plurality of emitters from reaching the plurality of detectors without first reaching the tissue; and
 - a processor configured to receive and process one or more signals responsive to the at least one outputted signal and determine a physiological parameter of the user responsive to the one or more signals.
3. The physiological monitoring device of claim 2, wherein the material is configured to change an output intensity profile of the light.
4. The physiological monitoring device of claim 2, further comprising a display configured to present visual feedback responsive to the determined physiological parameter.
5. The physiological monitoring device of claim 4, wherein the display is a touch-screen display.
6. The physiological monitoring device of claim 2, wherein the plurality of emitters and the plurality of detectors are arranged in a reflectance measurement configuration.
7. The physiological monitoring device of claim 2, wherein the light block comprises an at least partially circular shape, and wherein the plurality of emitters are positioned outside the light block and the plurality of detectors are positioned inside the light block.
8. The physiological monitoring device of claim 2, wherein the physiological parameter comprises pulse rate.
9. The physiological monitoring device of claim 2, wherein the material comprises plastic.
10. The physiological monitoring device of claim 2, wherein the material comprises glass.
11. The physiological monitoring device of claim 2, wherein the material is configured to disperse the light

emitted from the one or more of the plurality of emitters before the light reaches the tissue measurement site.

12. The physiological monitoring device of claim 2, wherein an amount of light transmitted by the material to the tissue measurement site is greater than 90% of the light emitted by the plurality of emitters.

13. The physiological monitoring device of claim 2, wherein the light emitted from the one or more of the plurality of emitters comprises a Gaussian intensity profile after interaction with the material.

14. The physiological monitoring device of claim 2, wherein the altered shape of the light after interaction with the material comprises a circular geometry.

15. The physiological monitoring device of claim 2, wherein the opening in the dark-colored coating comprises a width and a length, and wherein the width is larger than the length.

16. The physiological monitoring device of claim 2, wherein the dark-colored coating comprises black.

17. A method of measuring a physiological parameter, the method comprising:

emitting, from a plurality of emitters, light proximate a wrist of a user;

shaping at least a portion of the light emitted from the plurality of emitters before the light reaches the tissue measurement site;

permitting light reflected from tissue of the user to pass through an opening in a dark-colored coating on a surface and detecting, with a detector, at least a portion of the reflected light passing through the opening, wherein the surface is positioned between the detector and the tissue;

preventing at least a portion of the light emitted from the plurality of emitters from reaching the plurality of detectors without first reaching the tissue with a light block positioned between the plurality of emitters and the detector;

outputting, from the detector, at least one signal responsive to the detected light; and

electronically processing one or more signals responsive to the outputted at least one signal to determine a physiological parameter.

18. The method of claim 17, wherein the light block comprises an at least partially circular shape, and wherein the plurality of emitters are positioned outside the light block and the of detector is positioned inside the light block.

19. The method of claim 17, further comprising presenting, with a display, visual feedback responsive to the determined physiological parameter.

20. The method of claim 17, wherein the dark-colored coating comprises black.

21. The method of claim 17, wherein the step of shaping the at least the portion of the light emitted from the plurality of emitters is performed with a material comprising at least one of glass or plastic.

22. The method of claim 17, wherein the step of shaping the at least the portion of the light emitted from the plurality of emitters comprises spreading the at least the portion of the light before the light reaches the tissue measurement site.

23. The method of claim 17, wherein the opening in the dark-colored coating comprises a width and a length, and wherein the width is larger than the length.

24. A physiological monitoring device comprising:

a plurality of optical sources configured to emit light proximate a wrist of a user;

a material positioned between the plurality of optical sources and a tissue measurement site, wherein the material is configured to shape at least a portion of the light emitted from one or more of the plurality of emitters before the light reaches the tissue measurement site;

a plurality of detectors configured to detect the light after attenuation by tissue, the plurality of detectors further configured to output at least one signal responsive to the detected light, wherein the plurality of optical sources and the plurality of detectors are arranged in a reflectance measurement configuration;

a surface comprising a dark-colored coating, the surface positioned between the plurality of detectors and the tissue, the dark-colored coating comprising an opening configured to allow at least a portion of light reflected from the tissue to pass through the surface;

a light block between the plurality of optical sources and the plurality of detectors and configured to prevent at least a portion of light emitted from the plurality of optical sources from reaching the plurality of detectors without first reaching the tissue;

a processor configured to receive and process one or more signals responsive to the at least one outputted signal and determine a physiological parameter of the user responsive to the one or more signals; and

a touch-screen display configured to present visual feedback responsive to the determined physiological parameter;

wherein the physiological monitoring device is configured to wirelessly transmit physiological parameter data to a separate device.

25. The physiological monitoring device of claim 24, wherein the opening in the dark-colored coating comprises a width and a length, and wherein the width is larger than the length.

26. The physiological monitoring device of claim 24, wherein the material comprises at least one of glass or plastic.

27. A system configured to measure one or more physiological parameters of a user, the system comprising:

a physiological monitoring device comprising:

a plurality of emitters configured to emit light proximate a wrist of a user;

a material positioned between the plurality of emitters and a tissue measurement site, the material configured to alter a shape of the light emitted from one or more of the plurality of emitters before the light reaches the tissue measurement site;

a plurality of detectors configured to detect the light after attenuation by tissue, the plurality of detectors further configured to output at least one signal responsive to the detected light;

a surface comprising a dark-colored coating, the surface positioned between the plurality of detectors and the tissue, the dark-colored coating comprising an opening configured to allow at least a portion of light reflected from the tissue to pass through the surface;

a light block between the plurality of emitters and the plurality of detectors and configured to prevent at

least a portion of light from the plurality of emitters from reaching the plurality of detectors without first reaching the tissue; and

- a processor configured to receive and process one or more signals responsive to the outputted at least one signal and determine a physiological parameter of the user responsive to the one or more signals; and
- a processing device configured to wirelessly receive physiological parameter data from the physiological monitoring device, wherein the processing device comprises a user interface, a storage device, and a network interface configured to wirelessly communicate with the physiological monitoring device, and wherein the user interface includes a touch-screen display configured to present visual feedback responsive to the physiological parameter data.

28. The system of claim **27**, wherein the system is configured to determine a state of wellness of the user based on the determined physiological parameter.

29. The system of claim **27**, wherein the system is configured to determine a trend of wellness of the user based on the determined physiological parameter.

30. The system of claim **27**, wherein the visual feedback presented by the touch-screen display is responsive to a pulse rate of the user.

31. The system of claim **27**, wherein the material comprises at least one of glass or plastic.

* * * * *

| | | | |
|----------------|---|-----------------------|------------|
| 专利名称(译) | 先进的脉搏血氧饱和度传感器 | | |
| 公开(公告)号 | US20190350506A1 | 公开(公告)日 | 2019-11-21 |
| 申请号 | US16/532065 | 申请日 | 2019-08-05 |
| [标]申请(专利权)人(译) | 梅西莫股份有限公司 | | |
| 申请(专利权)人(译) | Masimo公司 | | |
| 当前申请(专利权)人(译) | Masimo公司 | | |
| [标]发明人 | AL ALI AMMAR | | |
| 发明人 | AL-ALI, AMMAR | | |
| IPC分类号 | A61B5/1455 A61B5/00 A61B5/145 A61B5/024 | | |
| CPC分类号 | A61B5/02416 A61B5/0002 A61B5/14546 A61B5/4875 A61B5/14552 A61B5/6826 A61B5/7278 A61B5/742 A61B2562/04 A61B5/14532 | | |
| 优先权 | 62/188430 2015-07-02 US | | |
| 其他公开文献 | US10646146 | | |
| 外部链接 | Espacenet | USPTO | |

摘要(译)

公开了基于光学的非侵入性生理监测系统。一个实施例包括配置为发射光的发射器。漫射器被配置为接收和扩散所发射的光，并在组织测量部位处发射所扩散的光。该系统还包括集中器，该集中器被配置为在已被组织测量部位衰减或反射后接收扩展光。聚光器还被配置为收集并聚光接收到的光，并将聚光发射到检测器。检测器被配置为检测会聚的光并传输代表检测到的光的信号。处理器被配置为接收发射的信号并确定组织测量部位中的生理参数，例如动脉血氧饱和度。

