



(19) **United States**

(12) **Patent Application Publication**
ZHANG

(10) **Pub. No.: US 2017/0203114 A1**

(43) **Pub. Date: Jul. 20, 2017**

(54) **METHOD AND APPARATUS FOR VERIFYING DISCRIMINATING OF TACHYCARDIA EVENTS IN A MEDICAL DEVICE HAVING DUAL SENSING VECTORS**

A61B 5/0464 (2006.01)
A61B 5/0452 (2006.01)
A61B 5/00 (2006.01)
A61B 5/042 (2006.01)
A61B 5/04 (2006.01)

(71) Applicant: **Medtronic, Inc.**, Minneapolis, MN (US)

(52) **U.S. Cl.**
CPC *A61N 1/3987* (2013.01); *A61B 5/0422* (2013.01); *A61B 5/0456* (2013.01); *A61B 5/04011* (2013.01); *A61B 5/0464* (2013.01); *A61B 5/04525* (2013.01); *A61B 5/686* (2013.01); *A61B 5/7207* (2013.01); *A61N 1/3621* (2013.01); *A61N 1/3956* (2013.01)

(72) Inventor: **Xusheng ZHANG**, Shoreview, MN (US)

(21) Appl. No.: **15/477,475**

(22) Filed: **Apr. 3, 2017**

(57) **ABSTRACT**

Related U.S. Application Data

(63) Continuation of application No. 14/339,156, filed on Jul. 23, 2014, now Pat. No. 9,610,025.

(60) Provisional application No. 62/019,658, filed on Jul. 1, 2014.

A method and medical device for detecting a cardiac event that includes sensing cardiac signals from a plurality of electrodes, sensing a plurality of beats in response to the sensed cardiac signals, identifying each beat of the plurality of beats as one of a normal beat and a not normal beat, determining at least one of whether a number of beats identified as a normal beat is greater than a normal beat threshold, whether an RR interval associated with the beats identified as being a normal beat is less than a threshold interval, and whether RR intervals associated with the beats identified as being normal beats are within an RR interval range, and identifying the cardiac event as being one of shockable and not shockable in response to the determining.

Publication Classification

(51) **Int. Cl.**
A61N 1/39 (2006.01)
A61B 5/0456 (2006.01)
A61N 1/362 (2006.01)

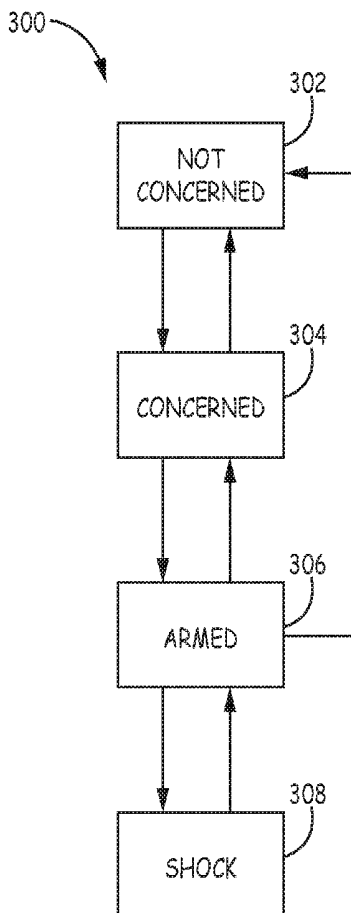

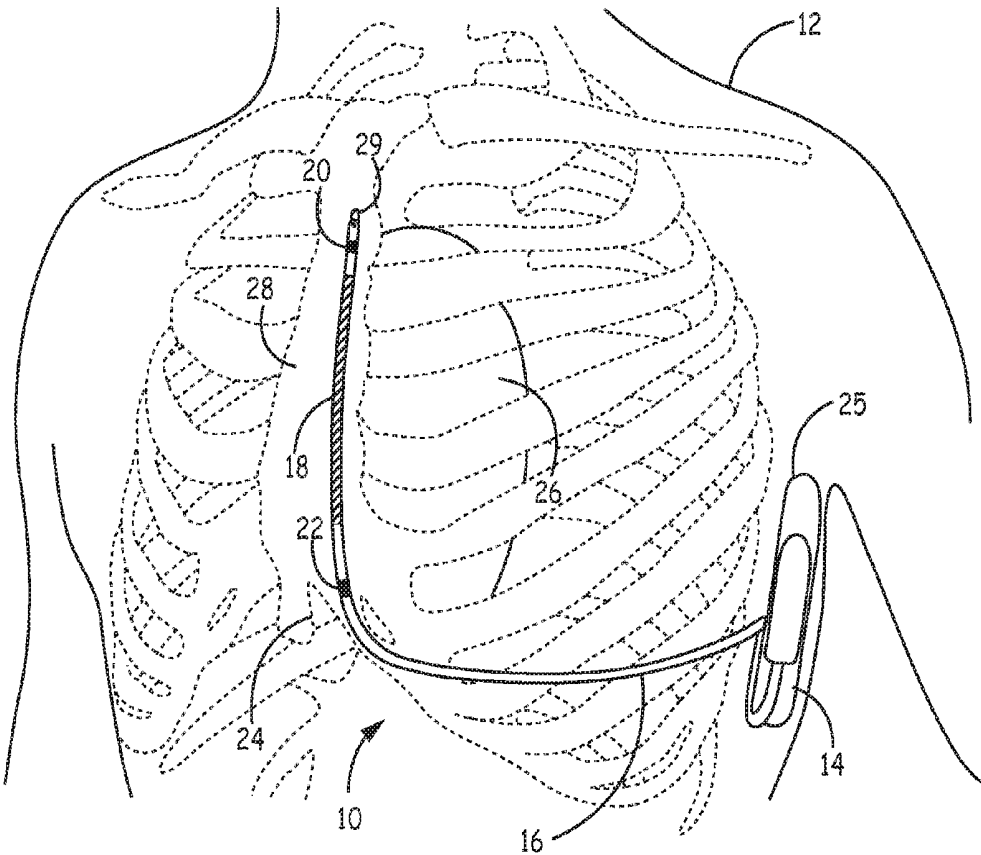

FIG. 1

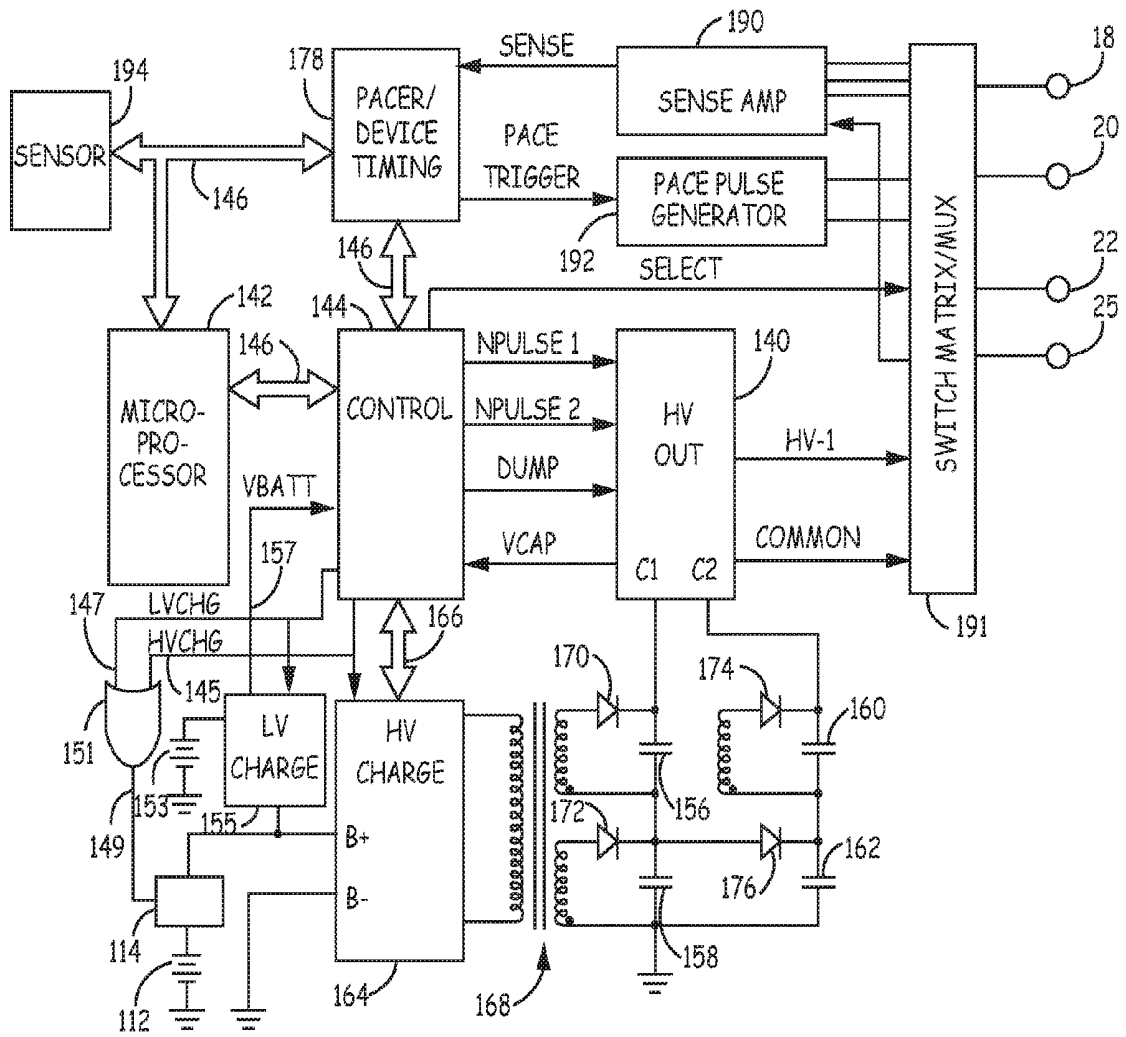

FIG. 2

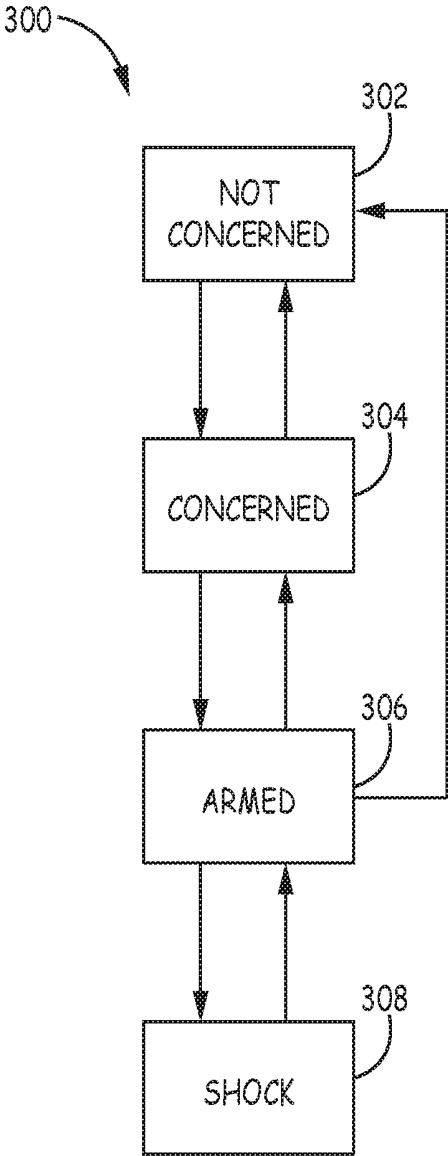

FIG. 3

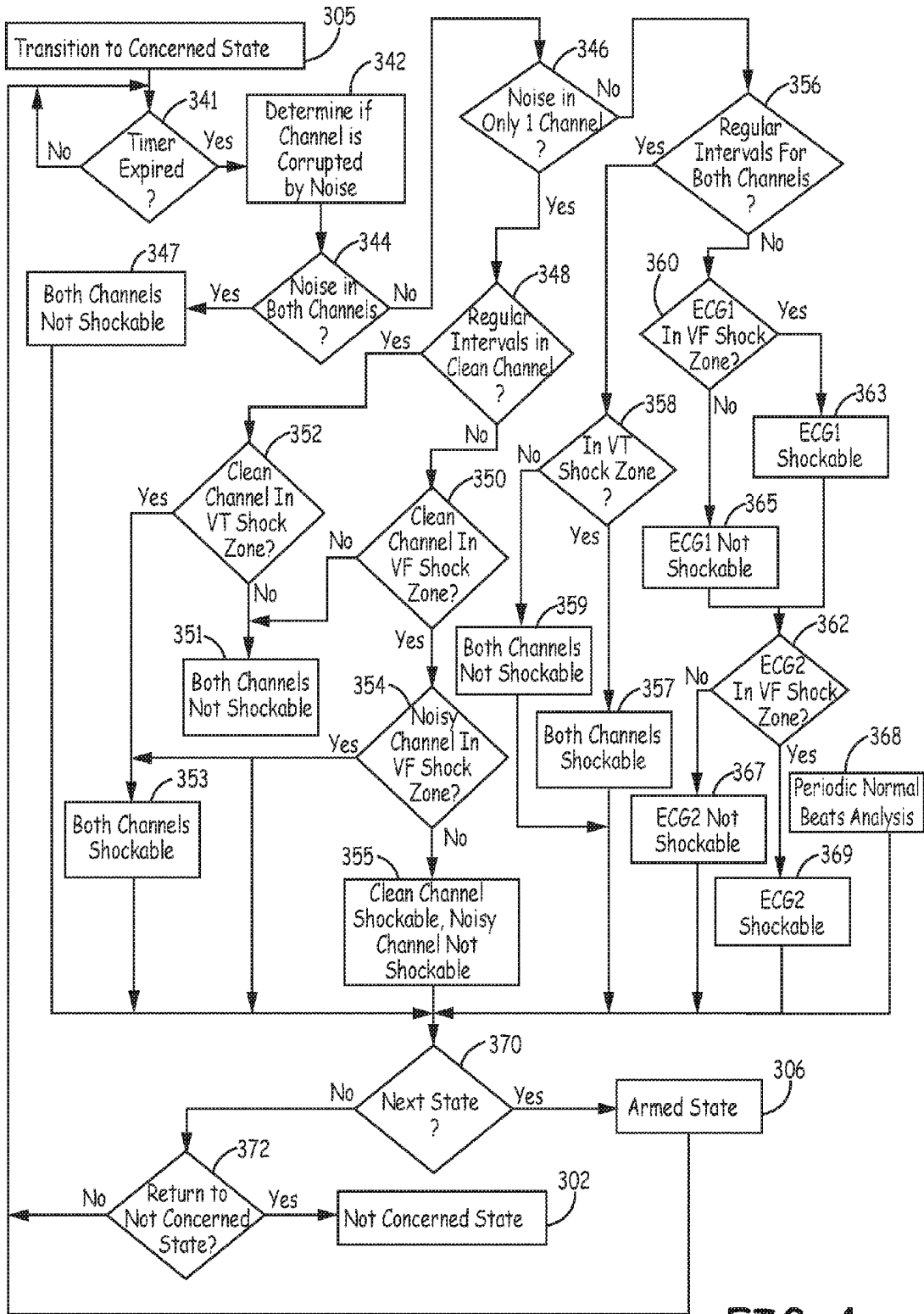

FIG. 4

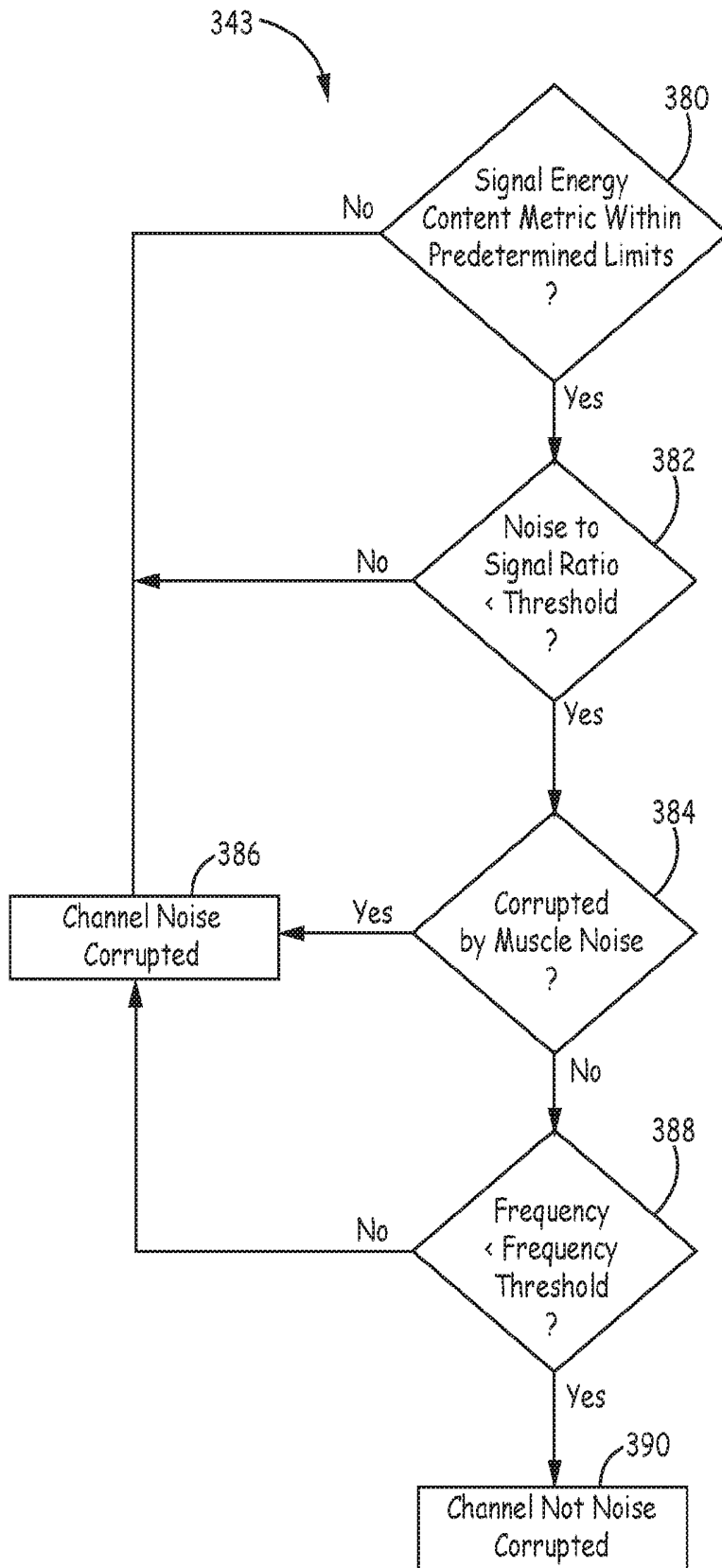

FIG. 5

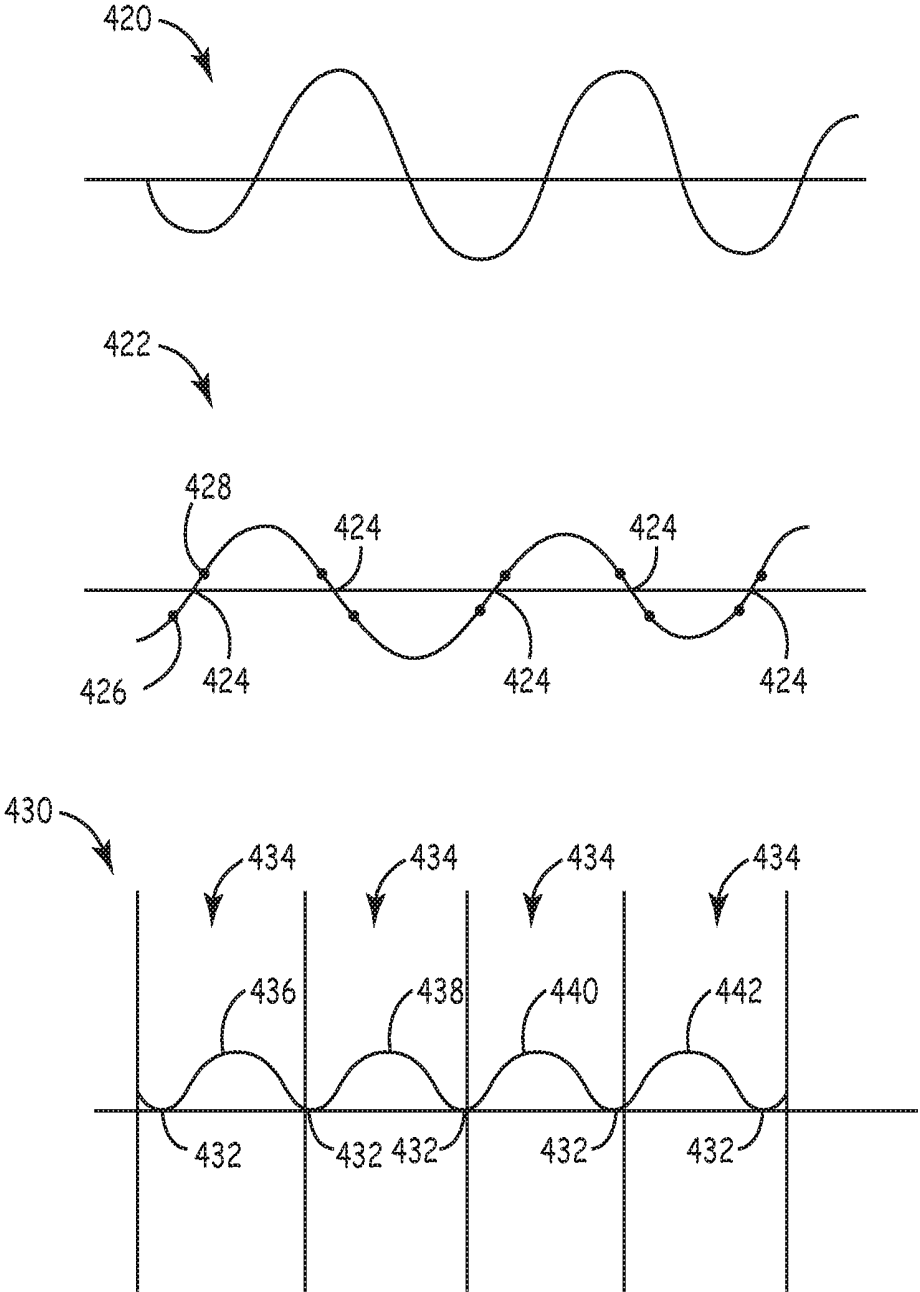

FIG. 6A

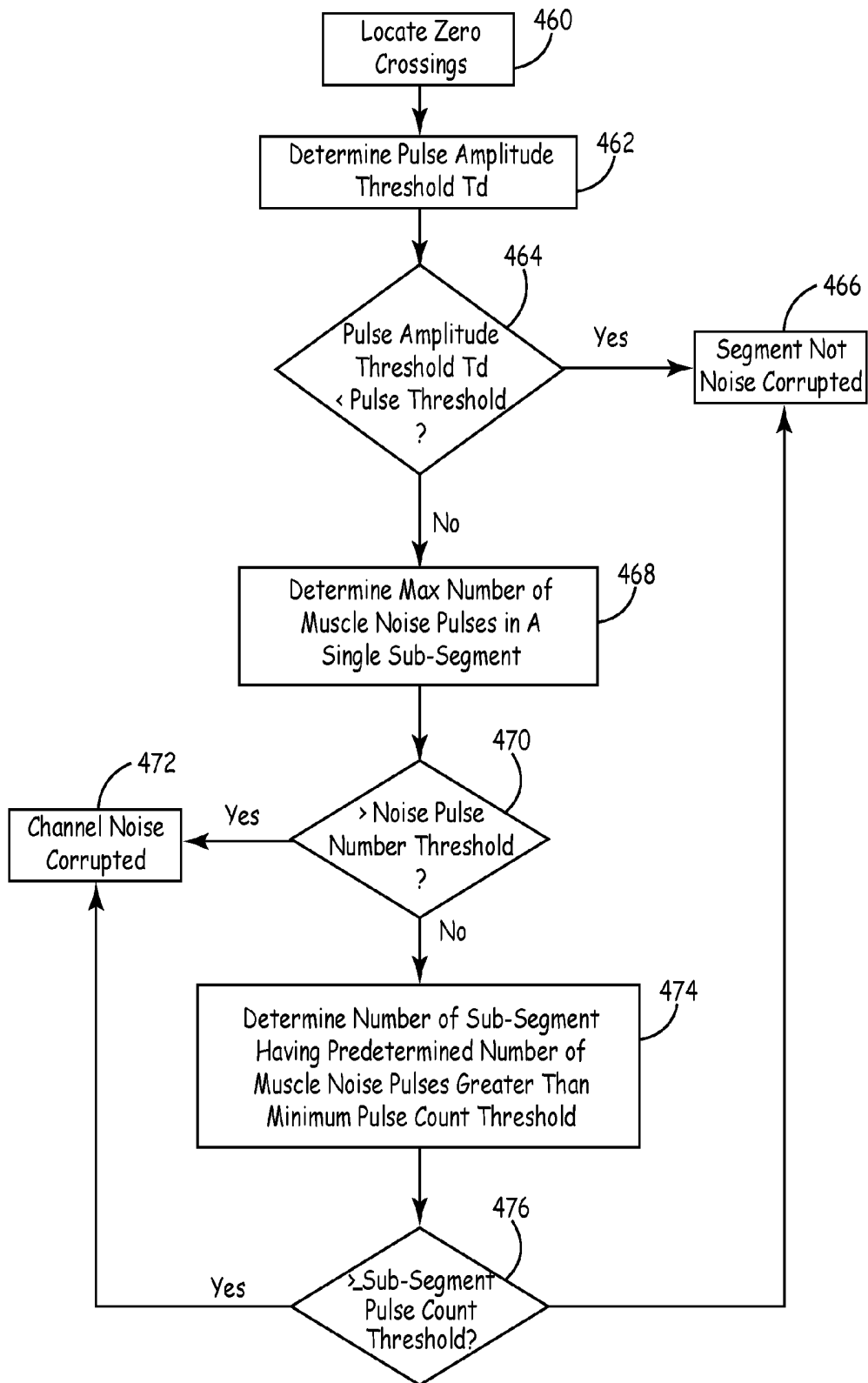

FIG. 6B

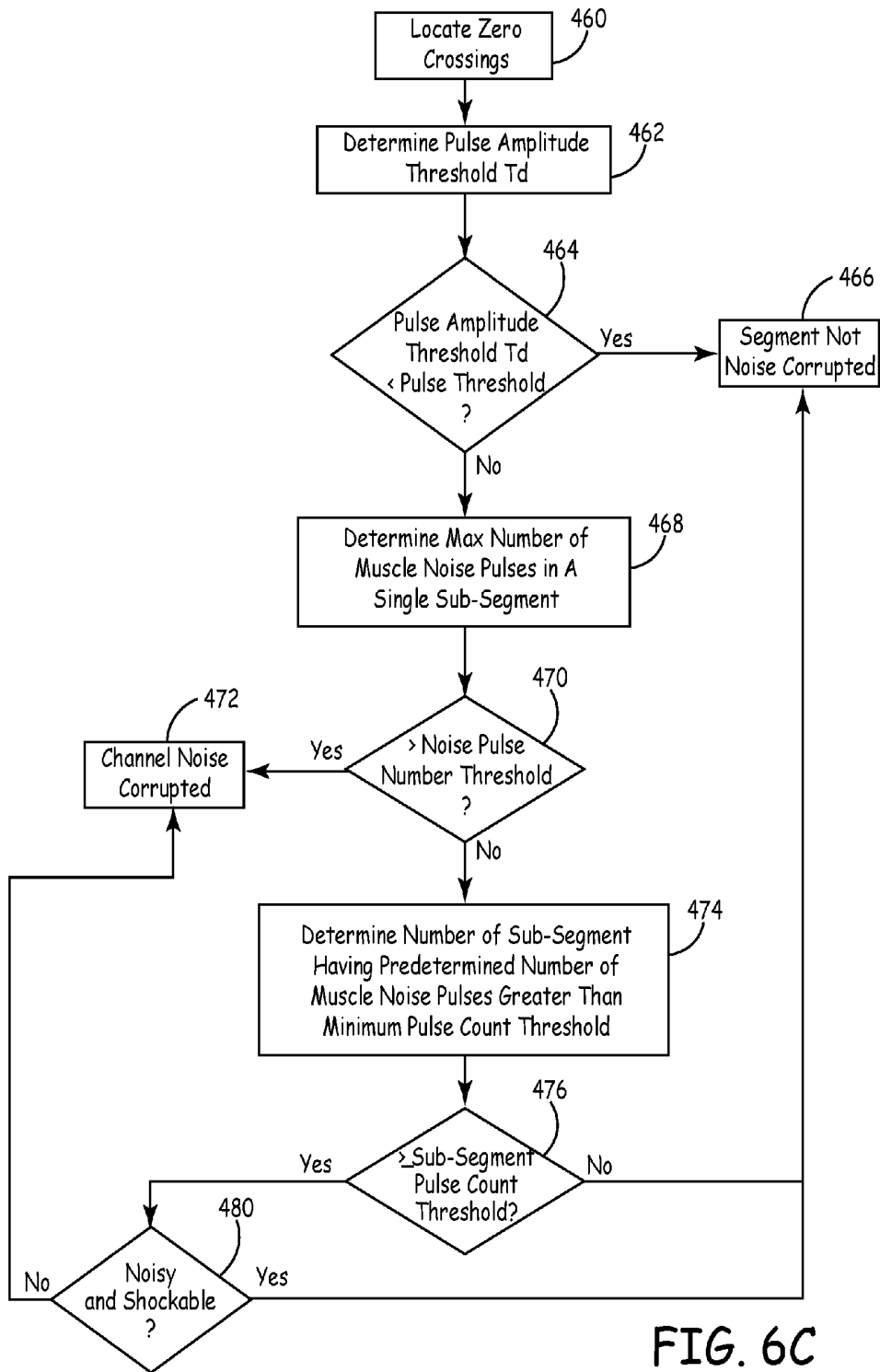

FIG. 6C

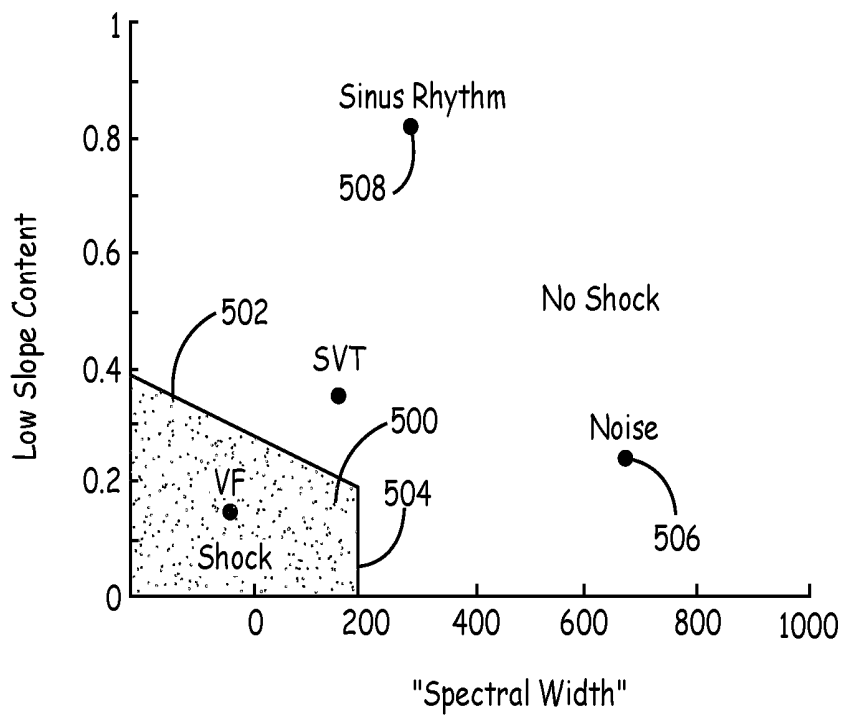

FIG. 7

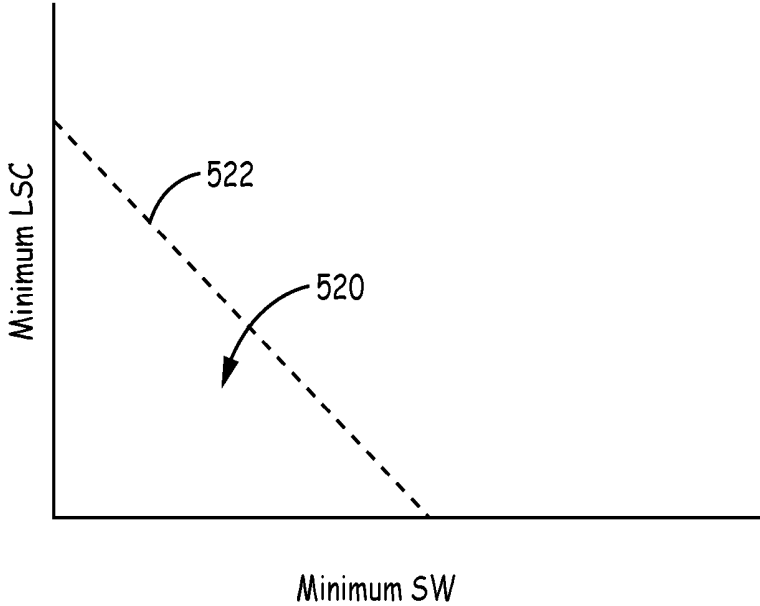

FIG. 8A

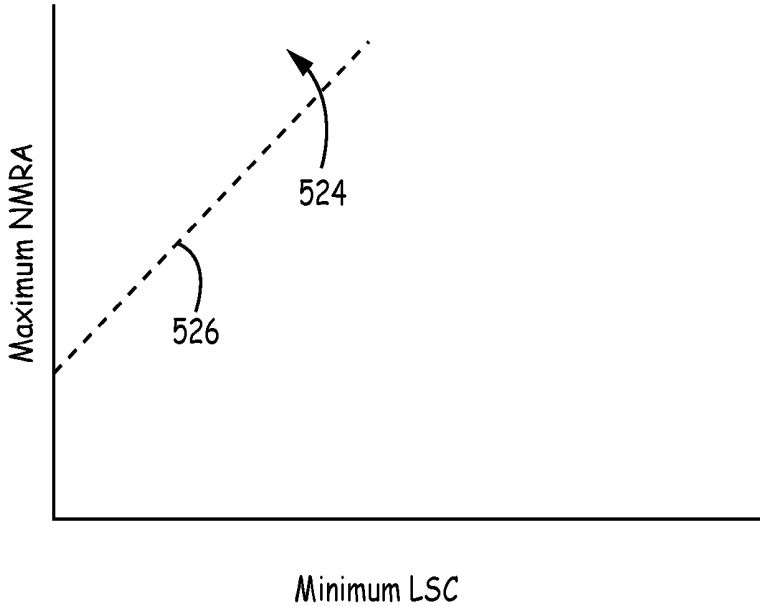

FIG. 8B

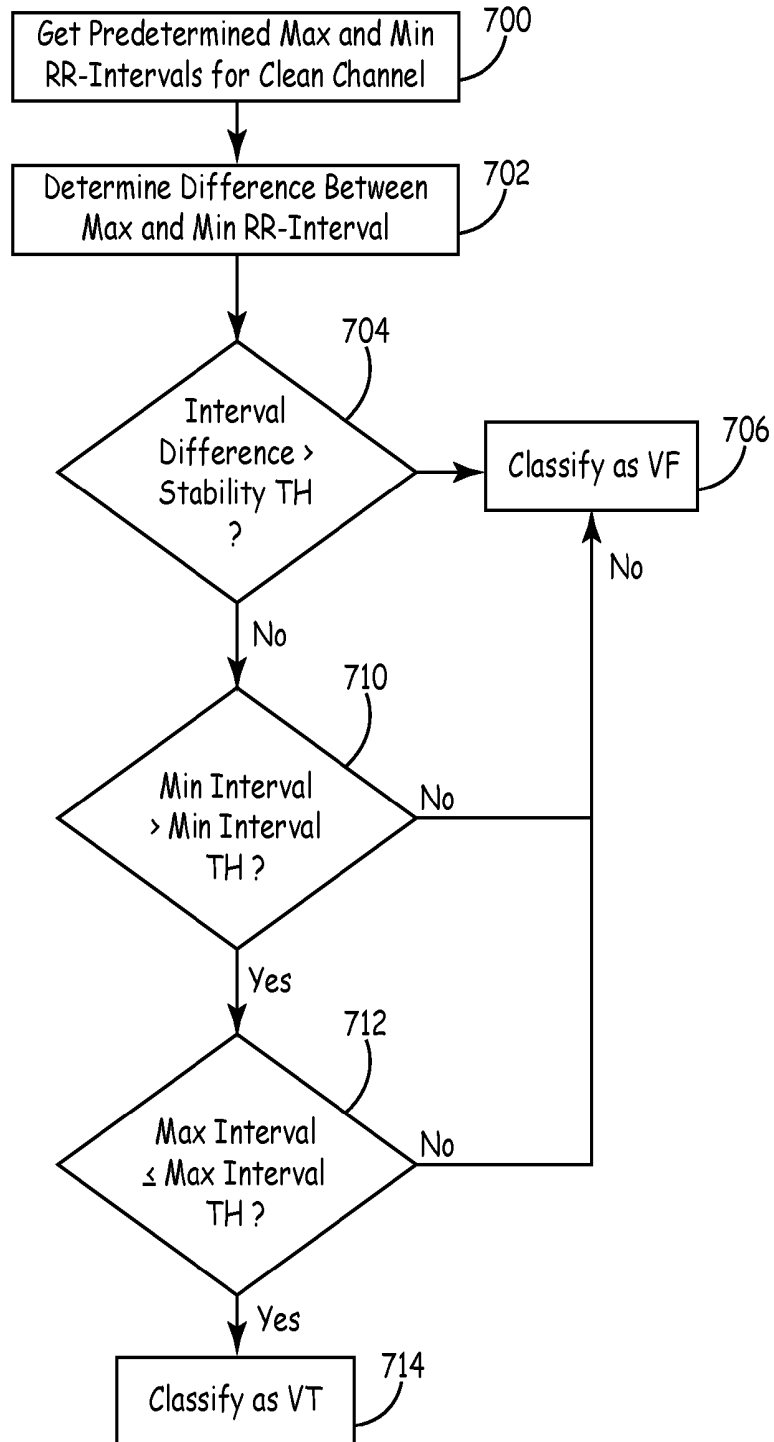

FIG. 9

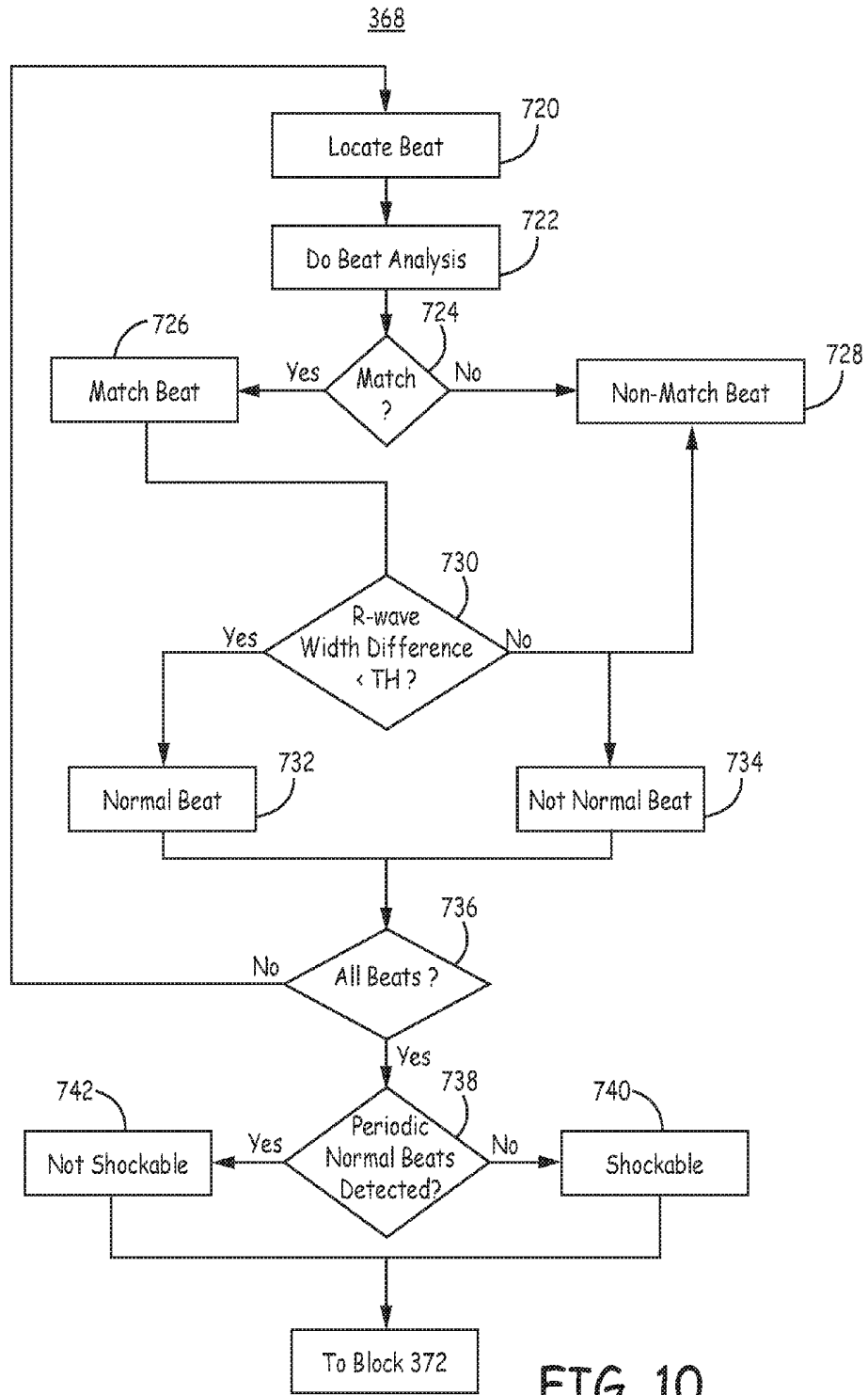

FIG. 10

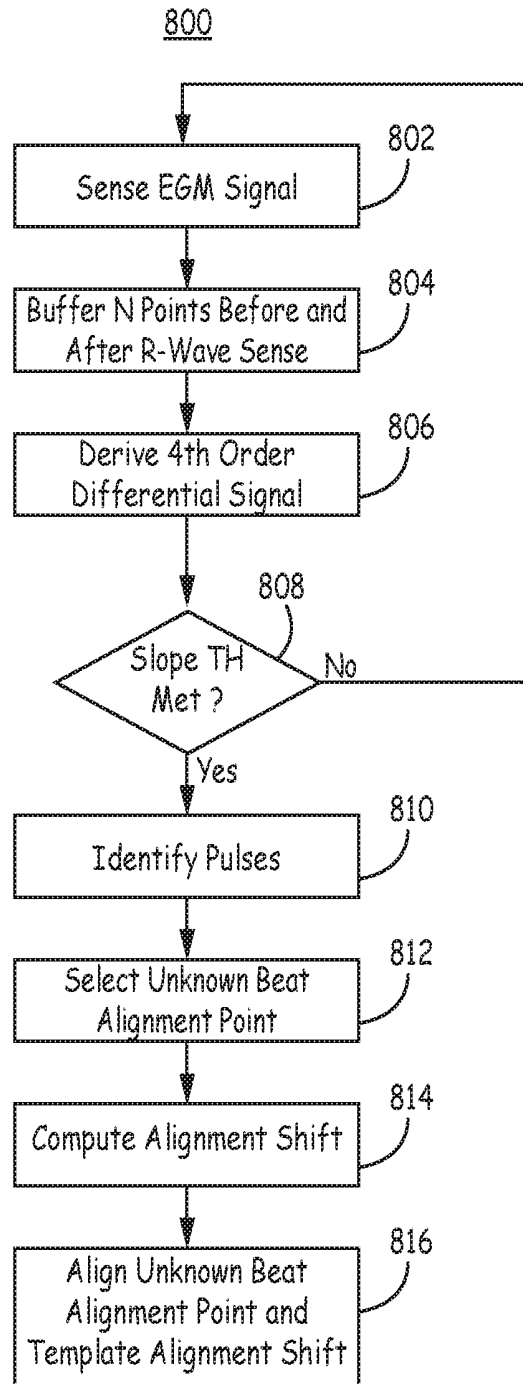

FIG. 11

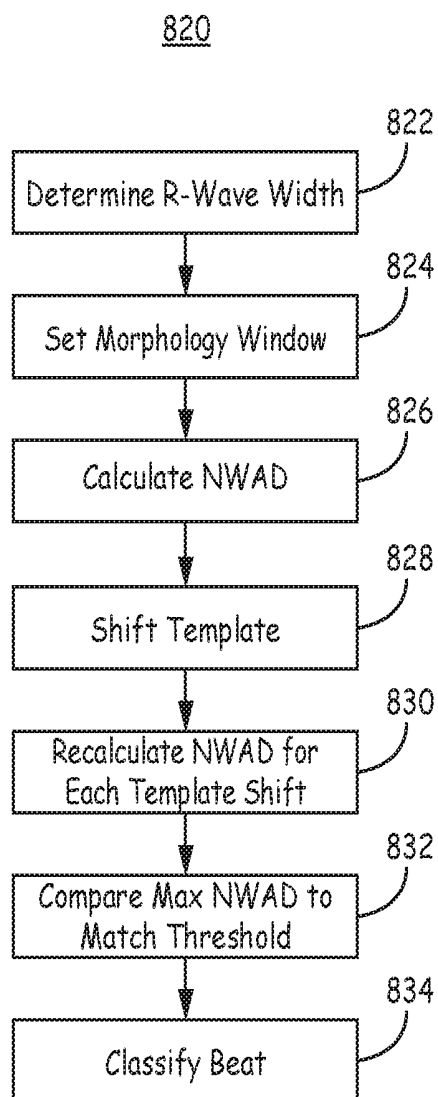

FIG. 12

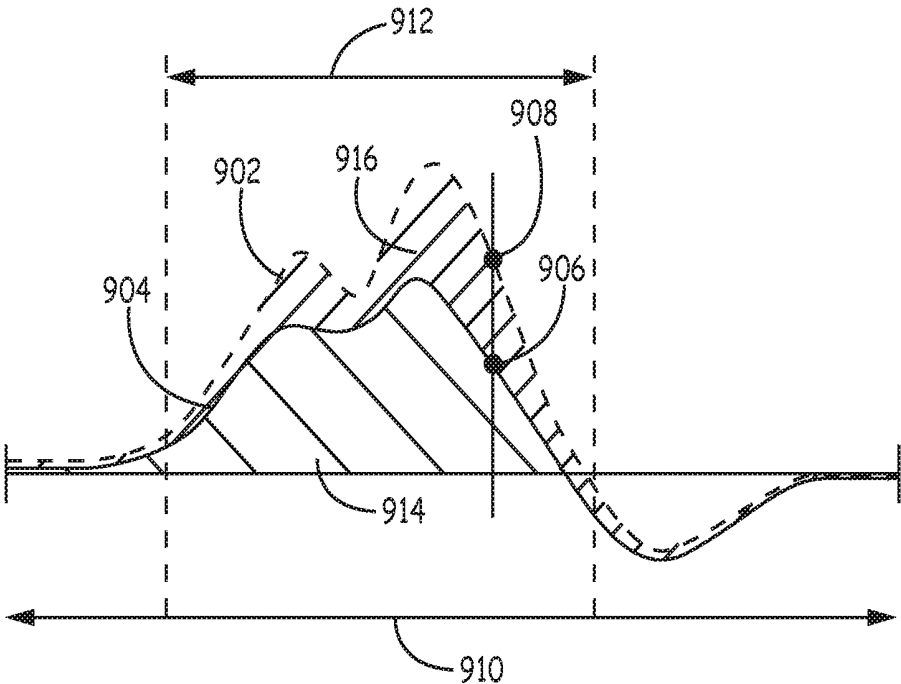

FIG. 13

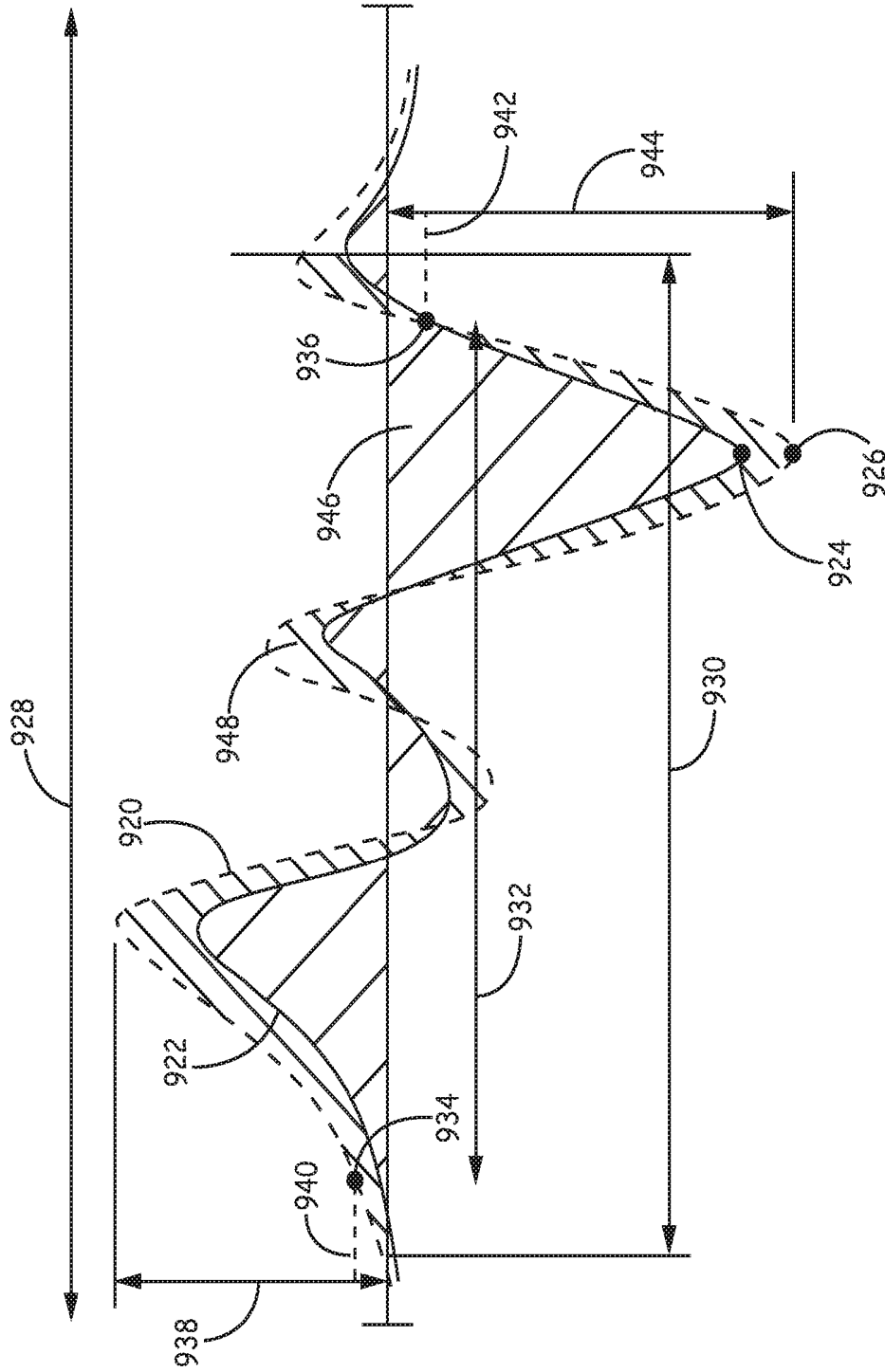

FIG. 14

738

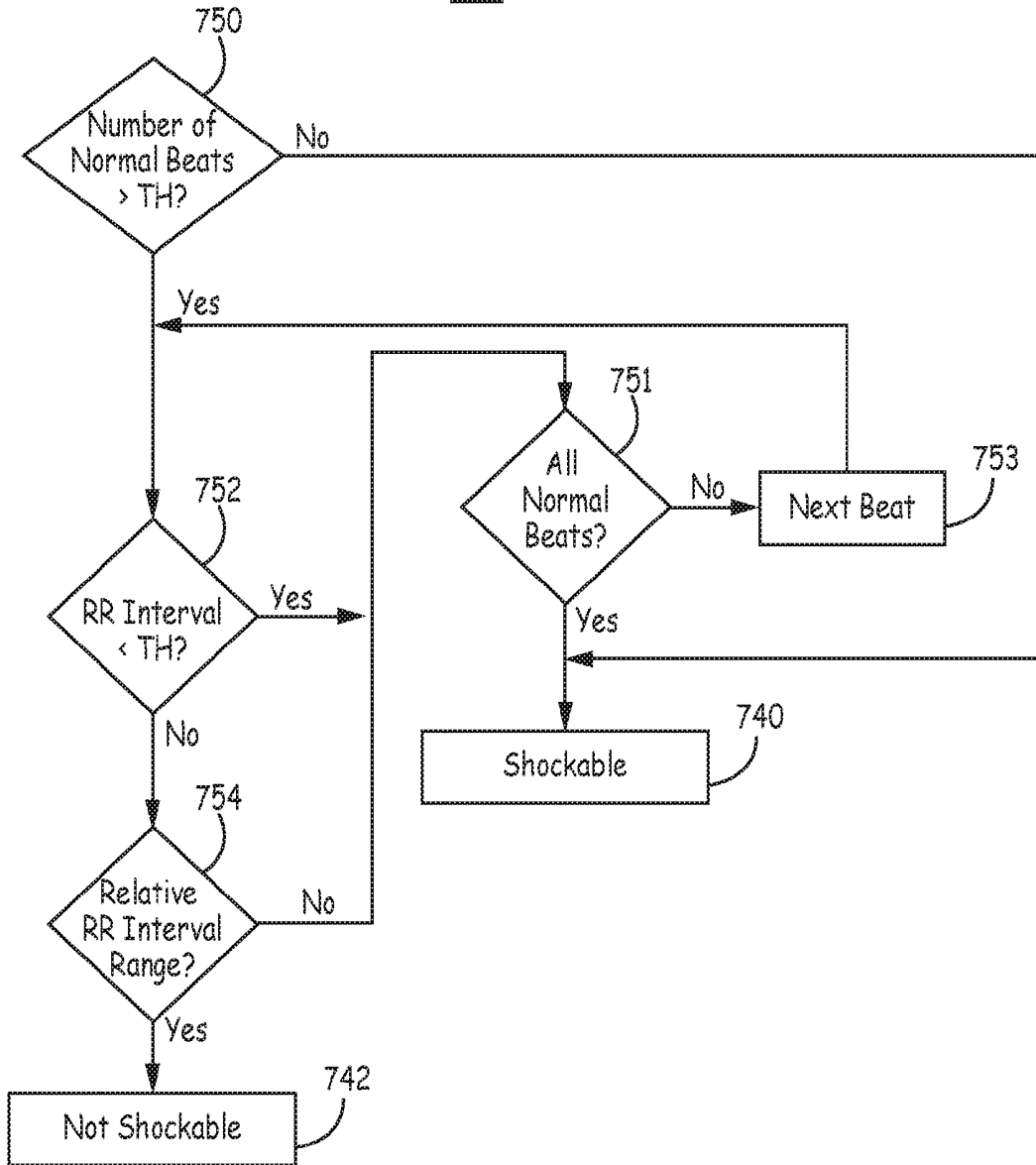

FIG. 15

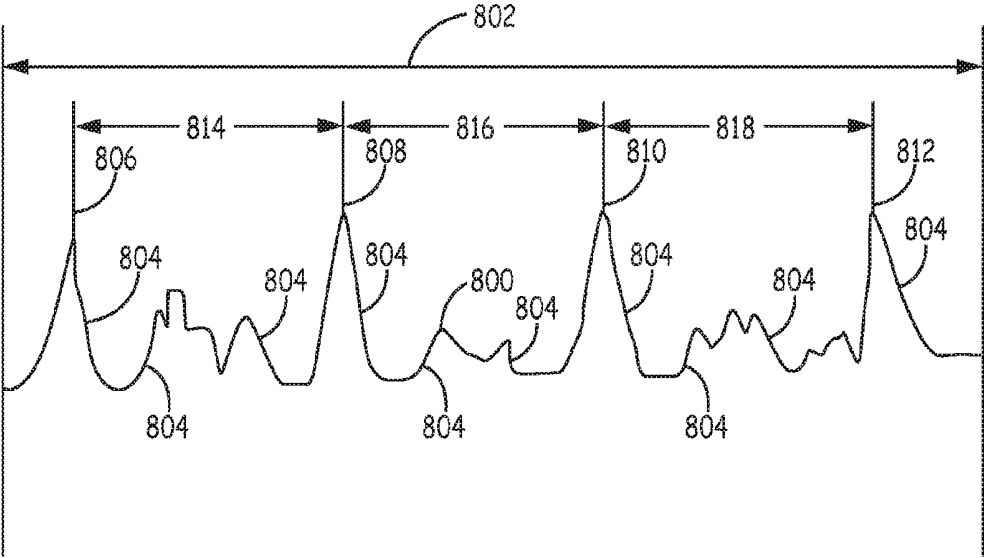

FIG. 16

738

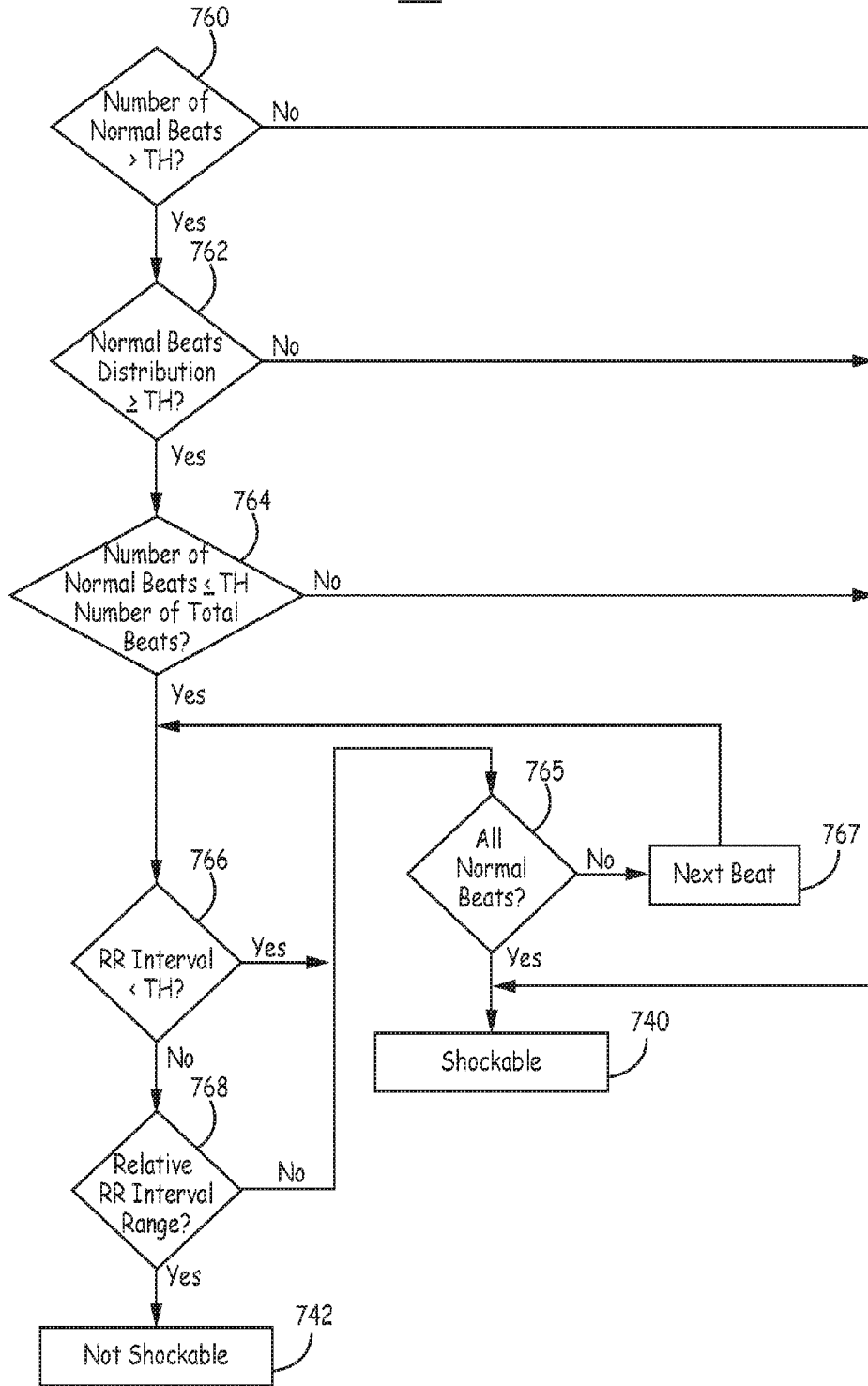

FIG. 17

**METHOD AND APPARATUS FOR
VERIFYING DISCRIMINATING OF
TACHYCARDIA EVENTS IN A MEDICAL
DEVICE HAVING DUAL SENSING VECTORS**

RELATED APPLICATION

[0001] The present application is a continuation of U.S. patent application Ser. No. 14/339,156, filed Jul. 23, 2014 (now granted), entitled "METHOD AND APPARATUS FOR VERIFYING DISCRIMINATING OF TACHYCARDIA EVENTS IN A MEDICAL DEVICE HAVING DUAL SENSING VECTORS," which claims priority and other benefits from U.S. Provisional Patent Application Ser. No. 62/019,658, filed Jul. 1, 2014, both of which are incorporated herein by reference in their entirety.

TECHNICAL FIELD

[0002] The disclosure relates generally to implantable medical devices and, in particular, to an apparatus and method for discriminating arrhythmias and delivering a therapy in a medical device.

BACKGROUND

[0003] Implantable medical devices are available for treating cardiac tachyarrhythmias by delivering anti-tachycardia pacing therapies and electrical shock therapies for cardioverting or defibrillating the heart. Such a device, commonly known as an implantable cardioverter defibrillator or "ICD", senses electrical activity from the heart, determines a patient's heart rate, and classifies the rate according to a number of heart rate zones in order to detect episodes of ventricular tachycardia or fibrillation. Typically a number of rate zones are defined according to programmable detection interval ranges for detecting slow ventricular tachycardia, fast ventricular tachycardia and ventricular fibrillation. Intervals between sensed R-waves, corresponding to the depolarization of the ventricles, are measured. Sensed R-R intervals falling into defined detection interval ranges are counted to provide a count of ventricular tachycardia (VT) or ventricular fibrillation (VF) intervals, for example. A programmable number of intervals to detect (NID) defines the number of tachycardia intervals occurring consecutively or out of a given number of preceding event intervals that are required to detect VT or VF.

[0004] Tachyarrhythmia detection may begin with detecting a fast ventricular rate, referred to as rate- or interval-based detection. Once VT or VF is detected based on rate, the morphology of the sensed depolarization signals, e.g. wave shape, amplitude or other features, may be used in discriminating heart rhythms to improve the sensitivity and specificity of tachyarrhythmia detection methods. A primary goal of a tachycardia detection algorithm is to rapidly respond to a potentially malignant rhythm with a therapy that will terminate the arrhythmia with high certainty. Another goal, however, is to avoid excessive use of ICD battery charge, which shortens the life of the ICD, e.g. due to delivering unnecessary therapies or therapies at a higher voltage than needed to terminate a detected tachyarrhythmia. Minimizing the patient's exposure to painful shock therapies is also an important consideration. Accordingly, a need remains for ICDs that perform tachycardia discrimination with high specificity and control therapy delivery to successfully terminate a detected VT requiring therapy

while conserving battery charge and limiting patient exposure to delivered shock therapy by withholding therapy delivery whenever possible in situations where the therapy may not be required.

BRIEF DESCRIPTION OF THE DRAWINGS

[0005] FIG. 1 is a conceptual diagram of a patient implanted with an example extravascular cardiac defibrillation system.

[0006] FIG. 2 is an exemplary schematic diagram of electronic circuitry within a hermetically sealed housing of a subcutaneous device according to an embodiment of the present invention.

[0007] FIG. 3 is a state diagram of detection of arrhythmias in a medical device according to an embodiment of the present invention.

[0008] FIG. 4 is a flowchart of a method for detecting arrhythmias in a subcutaneous device according to an embodiment of the present disclosure.

[0009] FIG. 5 is a flowchart of a method of determining noise according to an embodiment of the present disclosure.

[0010] FIG. 6A is a graphical representation of a determination of whether a signal is corrupted by muscle noise according to an embodiment of the present invention.

[0011] FIG. 6B is a flowchart of a method of determining whether a signal is corrupted by muscle noise according to an embodiment of the present invention.

[0012] FIG. 6C is a flowchart of a method of determining whether a signal is corrupted by muscle noise according to an embodiment of the present invention.

[0013] FIG. 7 is a graphical representation of a VF shock zone according to an embodiment of the present invention.

[0014] FIGS. 8A and 8B are graphical representations of the determination of whether an event is within a shock zone according to an embodiment of the present invention.

[0015] FIG. 9 is a flowchart of a method for discriminating cardiac events according to an embodiment of the disclosure.

[0016] FIG. 10 is a flowchart of a method for performing periodic normal beats analysis during detection of arrhythmias in a medical device, according to an embodiment of the present disclosure.

[0017] FIG. 11 is a flowchart of a method for aligning an ECG signal of an unknown beat with a known morphology template for beat-based analysis during detection of arrhythmias in a medical device, according to an embodiment of the present disclosure.

[0018] FIG. 12 is a flowchart of a method for computing a morphology metric to determine the similarity between a known template aligned with an unknown cardiac cycle signal according to one embodiment.

[0019] FIG. 13 is an exemplary plot of alignment of an unknown beat and a template for computing a normalized waveform area difference during beat-based analysis, according to one embodiment.

[0020] FIG. 14 is an exemplary plot illustrating a technique for determining an R-wave width and computing a normalized waveform area difference during beat-based analysis, according to another embodiment.

[0021] FIG. 15 is a flowchart of an exemplary method for determining whether periodic normal beats are detected within a predetermined sensing vector during the periodic normal beats analysis of FIG. 10.

[0022] FIG. 16 is a schematic diagram of an exemplary cardiac signal sensed within a sensing detection window during detection of a cardiac event.

[0023] FIG. 17 is a flowchart of an exemplary method for determining whether periodic normal beats are detected within a predetermined sensing vector during the periodic normal beats analysis of FIG. 10.

DETAILED DESCRIPTION

[0024] FIG. 1 is a conceptual diagram of a patient 12 implanted with an example extravascular cardiac defibrillation system 10. In the example illustrated in FIG. 1, extravascular cardiac defibrillation system 10 is an implanted subcutaneous ICD system. However, the techniques of this disclosure may also be utilized with other extravascular implanted cardiac defibrillation systems, such as a cardiac defibrillation system having a lead implanted at least partially in a substernal or submuscular location. Additionally, the techniques of this disclosure may also be utilized with other implantable systems, such as implantable pacing systems, implantable neurostimulation systems, drug delivery systems or other systems in which leads, catheters or other components are implanted at extravascular locations within patient 12. This disclosure, however, is described in the context of an implantable extravascular cardiac defibrillation system for purposes of illustration.

[0025] Extravascular cardiac defibrillation system 10 includes an implantable cardioverter defibrillator (ICD) 14 connected to at least one implantable cardiac defibrillation lead 16. ICD 14 of FIG. 1 is implanted subcutaneously on the left side of patient 12. Defibrillation lead 16, which is connected to ICD 14, extends medially from ICD 14 toward sternum 28 and xiphoid process 24 of patient 12. At a location near xiphoid process 24, defibrillation lead 16 bends or turns and extends subcutaneously superior, substantially parallel to sternum 28. In the example illustrated in FIG. 1, defibrillation lead 16 is implanted such that lead 16 is offset laterally to the left side of the body of sternum 28 (i.e., towards the left side of patient 12).

[0026] Defibrillation lead 16 is placed along sternum 28 such that a therapy vector between defibrillation electrode 18 and a second electrode (such as a housing or can 25 of ICD 14 or an electrode placed on a second lead) is substantially across the ventricle of heart 26. The therapy vector may, in one example, be viewed as a line that extends from a point on the defibrillation electrode 18 to a point on the housing or can 25 of ICD 14. In another example, defibrillation lead 16 may be placed along sternum 28 such that a therapy vector between defibrillation electrode 18 and the housing or can 25 of ICD 14 (or other electrode) is substantially across an atrium of heart 26. In this case, extravascular ICD system 10 may be used to provide atrial therapies, such as therapies to treat atrial fibrillation.

[0027] The embodiment illustrated in FIG. 1 is an example configuration of an extravascular ICD system 10 and should not be considered limiting of the techniques described herein. For example, although illustrated as being offset laterally from the midline of sternum 28 in the example of FIG. 1, defibrillation lead 16 may be implanted such that lead 16 is offset to the right of sternum 28 or more centrally located over sternum 28. Additionally, defibrillation lead 16 may be implanted such that it is not substantially parallel to sternum 28, but instead offset from sternum 28 at an angle (e.g., angled lateral from sternum 28 at either the proximal

or distal end). As another example, the distal end of defibrillation lead 16 may be positioned near the second or third rib of patient 12. However, the distal end of defibrillation lead 16 may be positioned further superior or inferior depending on the location of ICD 14, location of electrodes 18, 20, and 22, or other factors.

[0028] Although ICD 14 is illustrated as being implanted near a midaxillary line of patient 12, ICD 14 may also be implanted at other subcutaneous locations on patient 12, such as further posterior on the torso toward the posterior axillary line, further anterior on the torso toward the anterior axillary line, in a pectoral region, or at other locations of patient 12. In instances in which ICD 14 is implanted pectorally, lead 16 would follow a different path, e.g., across the upper chest area and inferior along sternum 28. When the ICD 14 is implanted in the pectoral region, the extravascular ICD system may include a second lead including a defibrillation electrode that extends along the left side of the patient such that the defibrillation electrode of the second lead is located along the left side of the patient to function as an anode or cathode of the therapy vector of such an ICD system.

[0029] ICD 14 includes a housing or can 25 that forms a hermetic seal that protects components within ICD 14. The housing 25 of ICD 14 may be formed of a conductive material, such as titanium or other biocompatible conductive material or a combination of conductive and non-conductive materials. In some instances, the housing 25 of ICD 14 functions as an electrode (referred to as a housing electrode or can electrode) that is used in combination with one of electrodes 18, 20, or 22 to deliver a therapy to heart 26 or to sense electrical activity of heart 26. ICD 14 may also include a connector assembly (sometimes referred to as a connector block or header) that includes electrical feedthroughs through which electrical connections are made between conductors within defibrillation lead 16 and electronic components included within the housing. Housing may enclose one or more components, including processors, memories, transmitters, receivers, sensors, sensing circuitry, therapy circuitry and other appropriate components (often referred to herein as modules).

[0030] Defibrillation lead 16 includes a lead body having a proximal end that includes a connector configured to connect to ICD 14 and a distal end that includes one or more electrodes 18, 20, and 22. The lead body of defibrillation lead 16 may be formed from a non-conductive material, including silicone, polyurethane, fluoropolymers, mixtures thereof, and other appropriate materials, and shaped to form one or more lumens within which the one or more conductors extend. However, the techniques are not limited to such constructions. Although defibrillation lead 16 is illustrated as including three electrodes 18, 20 and 22, defibrillation lead 16 may include more or fewer electrodes.

[0031] Defibrillation lead 16 includes one or more elongated electrical conductors (not illustrated) that extend within the lead body from the connector on the proximal end of defibrillation lead 16 to electrodes 18, 20 and 22. In other words, each of the one or more elongated electrical conductors contained within the lead body of defibrillation lead 16 may engage with respective ones of electrodes 18, 20 and 22. When the connector at the proximal end of defibrillation lead 16 is connected to ICD 14, the respective conductors may electrically couple to circuitry, such as a therapy module or a sensing module, of ICD 14 via connections in

connector assembly, including associated feedthroughs. The electrical conductors transmit therapy from a therapy module within ICD 14 to one or more of electrodes 18, 20 and 22 and transmit sensed electrical signals from one or more of electrodes 18, 20 and 22 to the sensing module within ICD 14.

[0032] ICD 14 may sense electrical activity of heart 26 via one or more sensing vectors that include combinations of electrodes 20 and 22 and the housing or can 25 of ICD 14. For example, ICD 14 may obtain electrical signals sensed using a sensing vector between electrodes 20 and 22, obtain electrical signals sensed using a sensing vector between electrode 20 and the conductive housing or can 25 of ICD 14, obtain electrical signals sensed using a sensing vector between electrode 22 and the conductive housing or can 25 of ICD 14, or a combination thereof. In some instances, ICD 14 may sense cardiac electrical signals using a sensing vector that includes defibrillation electrode 18, such as a sensing vector between defibrillation electrode 18 and one of electrodes 20 or 22, or a sensing vector between defibrillation electrode 18 and the housing or can 25 of ICD 14.

[0033] ICD may analyze the sensed electrical signals to detect tachycardia, such as ventricular tachycardia or ventricular fibrillation, and in response to detecting tachycardia may generate and deliver an electrical therapy to heart 26. For example, ICD 14 may deliver one or more defibrillation shocks via a therapy vector that includes defibrillation electrode 18 of defibrillation lead 16 and the housing or can 25. Defibrillation electrode 18 may, for example, be an elongated coil electrode or other type of electrode. In some instances, ICD 14 may deliver one or more pacing therapies prior to or after delivery of the defibrillation shock, such as anti-tachycardia pacing (ATP) or post shock pacing. In these instances,

[0034] ICD 14 may generate and deliver pacing pulses via therapy vectors that include one or both of electrodes 20 and 22 and/or the housing or can 25. Electrodes 20 and 22 may comprise ring electrodes, hemispherical electrodes, coil electrodes, helix electrodes, segmented electrodes, directional electrodes, or other types of electrodes, or combination thereof. Electrodes 20 and 22 may be the same type of electrodes or different types of electrodes, although in the example of FIG. 1 both electrodes 20 and 22 are illustrated as ring electrodes.

[0035] Defibrillation lead 16 may also include an attachment feature 29 at or toward the distal end of lead 16. The attachment feature 29 may be a loop, link, or other attachment feature. For example, attachment feature 29 may be a loop formed by a suture. As another example, attachment feature 29 may be a loop, link, ring of metal, coated metal or a polymer. The attachment feature 29 may be formed into any of a number of shapes with uniform or varying thickness and varying dimensions. Attachment feature 29 may be integral to the lead or may be added by the user prior to implantation. Attachment feature 29 may be useful to aid in implantation of lead 16 and/or for securing lead 16 to a desired implant location. In some instances, defibrillation lead 16 may include a fixation mechanism in addition to or instead of the attachment feature. Although defibrillation lead 16 is illustrated with an attachment feature 29, in other examples lead 16 may not include an attachment feature 29.

[0036] Lead 16 may also include a connector at the proximal end of lead 16, such as a DF4 connector, bifurcated connector (e.g., DF-1/IS-1 connector), or other type of

connector. The connector at the proximal end of lead 16 may include a terminal pin that couples to a port within the connector assembly of ICD 14. In some instances, lead 16 may include an attachment feature at the proximal end of lead 16 that may be coupled to an implant tool to aid in implantation of lead 16. The attachment feature at the proximal end of the lead may separate from the connector and may be either integral to the lead or added by the user prior to implantation.

[0037] Defibrillation lead 16 may also include a suture sleeve or other fixation mechanism (not shown) located proximal to electrode 22 that is configured to fixate lead 16 near the xiphoid process or lower sternum location. The fixation mechanism (e.g., suture sleeve or other mechanism) may be integral to the lead or may be added by the user prior to implantation.

[0038] The example illustrated in FIG. 1 is exemplary in nature and should not be considered limiting of the techniques described in this disclosure. For instance, extravascular cardiac defibrillation system 10 may include more than one lead. In one example, extravascular cardiac defibrillation system 10 may include a pacing lead in addition to defibrillation lead 16.

[0039] In the example illustrated in FIG. 1, defibrillation lead 16 is implanted subcutaneously, e.g., between the skin and the ribs or sternum. In other instances, defibrillation lead 16 (and/or the optional pacing lead) may be implanted at other extravascular locations. In one example, defibrillation lead 16 may be implanted at least partially in a substernal location. In such a configuration, at least a portion of defibrillation lead 16 may be placed under or below the sternum in the mediastinum and, more particularly, in the anterior mediastinum. The anterior mediastinum is bounded laterally by pleurae, posteriorly by pericardium, and anteriorly by sternum 28. Defibrillation lead 16 may be at least partially implanted in other extra-pericardial locations, i.e., locations in the region around, but not in direct contact with, the outer surface of heart 26. These other extra-pericardial locations may include in the mediastinum but offset from sternum 28, in the superior mediastinum, in the middle mediastinum, in the posterior mediastinum, in the sub-xiphoid or inferior xiphoid area, near the apex of the heart, or other location not in direct contact with heart 26 and not subcutaneous. In still further instances, the lead may be implanted at a pericardial or epicardial location outside of the heart 26.

[0040] FIG. 2 is an exemplary schematic diagram of electronic circuitry within a hermetically sealed housing of a subcutaneous device according to an embodiment of the present invention. As illustrated in FIG. 2, subcutaneous device 14 includes a low voltage battery 153 coupled to a power supply (not shown) that supplies power to the circuitry of the subcutaneous device 14 and the pacing output capacitors to supply pacing energy in a manner well known in the art. The low voltage battery 153 may be formed of one or two conventional LiCF_x , LiMnO_2 or LiI_2 cells, for example. The subcutaneous device 14 also includes a high voltage battery 112 that may be formed of one or two conventional LiSVO or LiMnO_2 cells. Although two both low voltage battery and a high voltage battery are shown in FIG. 2, according to an embodiment of the present invention, the device 14 could utilize a single battery for both high and low voltage uses.

[0041] Further referring to FIG. 2, subcutaneous device **14** functions are controlled by means of software, firmware and hardware that cooperatively monitor the ECG signal, determine when a cardioversion-defibrillation shock or pacing is necessary, and deliver prescribed cardioversion-defibrillation and pacing therapies. The subcutaneous device **14** may incorporate circuitry set forth in commonly assigned U.S. Pat. Nos. 5,163,427 "Apparatus for Delivering Single and Multiple Cardioversion and Defibrillation Pulses" to Keimel and U.S. Pat. No. 5,188,105 "Apparatus and Method for Treating a Tachyarrhythmia" to Keimel for selectively delivering single phase, simultaneous biphasic and sequential biphasic cardioversion-defibrillation shocks typically employing ICD IPG housing electrodes **28** coupled to the COMMON output **123** of high voltage output circuit **140** and cardioversion-defibrillation electrode **24** disposed posteriorly and subcutaneously and coupled to the HVI output **113** of the high voltage output circuit **140**.

[0042] The cardioversion-defibrillation shock energy and capacitor charge voltages can be intermediate to those supplied by ICDs having at least one cardioversion-defibrillation electrode in contact with the heart and most AEDs having cardioversion-defibrillation electrodes in contact with the skin. The typical maximum voltage necessary for ICDs using most biphasic waveforms is approximately 750 Volts with an associated maximum energy of approximately 40 Joules. The typical maximum voltage necessary for AEDs is approximately 2000-5000 Volts with an associated maximum energy of approximately 200-360 Joules depending upon the model and waveform used. The subcutaneous device **14** of the present invention uses maximum voltages in the range of about 300 to approximately 1000 Volts and is associated with energies of approximately 25 to 150 joules or more. The total high voltage capacitance could range from about 50 to about 300 microfarads. Such cardioversion-defibrillation shocks are only delivered when a malignant tachyarrhythmia, e.g., ventricular fibrillation is detected through processing of the far field cardiac ECG employing the detection algorithms as described herein below.

[0043] In FIG. 2, sense amp **190** in conjunction with pacer/device timing circuit **178** processes the far field ECG sense signal that is developed across a particular ECG sense vector defined by a selected pair of the subcutaneous electrodes **18**, **20**, **22** and the can or housing **25** of the device **14**, or, optionally, a virtual signal (i.e., a mathematical combination of two vectors) if selected. The selection of the sensing electrode pair is made through the switch matrix/MUX **191** in a manner to provide the most reliable sensing of the ECG signal of interest, which would be the R wave for patients who are believed to be at risk of ventricular fibrillation leading to sudden death. The far field ECG signals are passed through the switch matrix/MUX **191** to the input of the sense amplifier **190** that, in conjunction with pacer/device timing circuit **178**, evaluates the sensed EGM. Bradycardia, or asystole, is typically determined by an escape interval timer within the pacer timing circuit **178** and/or the control circuit **144**. Pace Trigger signals are applied to the pacing pulse generator **192** generating pacing stimulation when the interval between successive R-waves exceeds the escape interval. Bradycardia pacing is often temporarily provided to maintain cardiac output after delivery of a cardioversion-defibrillation shock that may cause the heart to slowly beat as it recovers back to normal function. Sensing subcutaneous far field signals in the pres-

ence of noise may be aided by the use of appropriate denial and extensible accommodation periods as described in U.S. Pat. No. 6,236,882 "Noise Rejection for Monitoring ECGs" to Lee, et al and incorporated herein by reference in its entirety.

[0044] Detection of a malignant tachyarrhythmia is determined in the Control circuit **144** as a function of the intervals between R-wave sense event signals that are output from the pacer/device timing **178** and sense amplifier circuit **190** to the timing and control circuit **144**. It should be noted that the present invention utilizes not only interval based signal analysis method but also supplemental sensors and morphology processing method and apparatus as described herein below.

[0045] Supplemental sensors such as tissue color, tissue oxygenation, respiration, patient activity and the like may be used to contribute to the decision to apply or withhold a defibrillation therapy as described generally in U.S. Pat. No. 5,464,434 "Medical Interventional Device Responsive to Sudden Hemodynamic Change" to Alt and incorporated herein by reference in its entirety. Sensor processing block **194** provides sensor data to microprocessor **142** via data bus **146**. Specifically, patient activity and/or posture may be determined by the apparatus and method as described in U.S. Pat. No. 5,593,431 "Medical Service Employing Multiple DC Accelerometers for Patient Activity and Posture Sensing and Method" to Sheldon and incorporated herein by reference in its entirety. Patient respiration may be determined by the apparatus and method as described in U.S. Pat. No. 4,567,892 "Implantable Cardiac Pacemaker" to Plicchi, et al and incorporated herein by reference in its entirety. Patient tissue oxygenation or tissue color may be determined by the sensor apparatus and method as described in U.S. Pat. No. 5,176,137 to Erickson, et al and incorporated herein by reference in its entirety. The oxygen sensor of the '137 patent may be located in the subcutaneous device pocket or, alternatively, located on the lead **18** to enable the sensing of contacting or near-contacting tissue oxygenation or color.

[0046] Certain steps in the performance of the detection algorithm criteria are cooperatively performed in microcomputer **142**, including microprocessor, RAM and ROM, associated circuitry, and stored detection criteria that may be programmed into RAM via a telemetry interface (not shown) conventional in the art. Data and commands are exchanged between microcomputer **142** and timing and control circuit **144**, pacer timing/amplifier circuit **178**, and high voltage output circuit **140** via a bi-directional data/control bus **146**. The pacer timing/amplifier circuit **178** and the control circuit **144** are clocked at a slow clock rate. The microcomputer **142** is normally asleep, but is awakened and operated by a fast clock by interrupts developed by each R-wave sense event, on receipt of a downlink telemetry programming instruction or upon delivery of cardiac pacing pulses to perform any necessary mathematical calculations, to perform tachycardia and fibrillation detection procedures, and to update the time intervals monitored and controlled by the timers in pacer/device timing circuitry **178**.

[0047] When a malignant tachycardia is detected, high voltage capacitors **156**, **158**, **160**, and **162** are charged to a pre-programmed voltage level by a high-voltage charging circuit **164**. It is generally considered inefficient to maintain a constant charge on the high voltage output capacitors **156**, **158**, **160**, **162**. Instead, charging is initiated when control circuit **144** issues a high voltage charge command HVCHG

delivered on line **145** to high voltage charge circuit **164** and charging is controlled by means of bi-directional control/data bus **166** and a feedback signal VCAP from the HV output circuit **140**. High voltage output capacitors **156**, **158**, **160** and **162** may be of film, aluminum electrolytic or wet tantalum construction.

[0048] The negative terminal of high voltage battery **112** is directly coupled to system ground. Switch circuit **114** is normally open so that the positive terminal of high voltage battery **112** is disconnected from the positive power input of the high voltage charge circuit **164**. The high voltage charge command HVCHG is also conducted via conductor **149** to the control input of switch circuit **114**, and switch circuit **114** closes in response to connect positive high voltage battery voltage EXT B+ to the positive power input of high voltage charge circuit **164**. Switch circuit **114** may be, for example, a field effect transistor (FET) with its source-to-drain path interrupting the EXT B+ conductor **118** and its gate receiving the HVCHG signal on conductor **145**. High voltage charge circuit **164** is thereby rendered ready to begin charging the high voltage output capacitors **156**, **158**, **160**, and **162** with charging current from high voltage battery **112**.

[0049] High voltage output capacitors **156**, **158**, **160**, and **162** may be charged to very high voltages, e.g., 300-1000V, to be discharged through the body and heart between the electrode pair of subcutaneous cardioversion-defibrillation electrodes **113** and **123**. The details of the voltage charging circuitry are also not deemed to be critical with regard to practicing the present invention; one high voltage charging circuit believed to be suitable for the purposes of the present invention is disclosed. High voltage capacitors **156**, **158**, **160** and **162** may be charged, for example, by high voltage charge circuit **164** and a high frequency, high-voltage transformer **168** as described in detail in commonly assigned U.S. Pat. No. 4,548,209 "Energy Converter for Implantable Cardioverter" to Welders, et al. Proper charging polarities are maintained by diodes **170**, **172**, **174** and **176** interconnecting the output windings of high-voltage transformer **168** and the capacitors **156**, **158**, **160**, and **162**. As noted above, the state of capacitor charge is monitored by circuitry within the high voltage output circuit **140** that provides a VCAP, feedback signal indicative of the voltage to the timing and control circuit **144**. Timing and control circuit **144** terminates the high voltage charge command HVCHG when the VCAP signal matches the programmed capacitor output voltage, i.e., the cardioversion-defibrillation peak shock voltage.

[0050] Control circuit **144** then develops first and second control signals NPULSE **1** and NPULSE **2**, respectively, that are applied to the high voltage output circuit **140** for triggering the delivery of cardioverting or defibrillating shocks. In particular, the NPULSE **1** signal triggers discharge of the first capacitor bank, comprising capacitors **156** and **158**. The NPULSE **2** signal triggers discharge of the first capacitor bank and a second capacitor bank, comprising capacitors **160** and **162**. It is possible to select between a plurality of output pulse regimes simply by modifying the number and time order of assertion of the NPULSE **1** and NPULSE **2** signals. The NPULSE **1** signals and NPULSE **2** signals may be provided sequentially, simultaneously or individually. In this way, control circuitry **144** serves to control operation of the high voltage output stage **140**, which delivers high energy cardioversion-defibrillation shocks

between the pair of the cardioversion-defibrillation electrodes **18** and **25** coupled to the HV-1 and COMMON output as shown in FIG. 2.

[0051] Thus, subcutaneous device **14** monitors the patient's cardiac status and initiates the delivery of a cardioversion-defibrillation shock through the cardioversion-defibrillation electrodes **18** and **25** in response to detection of a tachyarrhythmia requiring cardioversion-defibrillation. The high HVCHG signal causes the high voltage battery **112** to be connected through the switch circuit **114** with the high voltage charge circuit **164** and the charging of output capacitors **156**, **158**, **160**, and **162** to commence. Charging continues until the programmed charge voltage is reflected by the VCAP signal, at which point control and timing circuit **144** sets the HVCHG signal low terminating charging and opening switch circuit **114**. The subcutaneous device **14** can be programmed to attempt to deliver cardioversion shocks to the heart in the manners described above in timed synchrony with a detected R-wave or can be programmed or fabricated to deliver defibrillation shocks to the heart in the manners described above without attempting to synchronize the delivery to a detected R-wave. Episode data related to the detection of the tachyarrhythmia and delivery of the cardioversion-defibrillation shock can be stored in RAM for uplink telemetry transmission to an external programmer as is well known in the art to facilitate in diagnosis of the patient's cardiac state. A patient receiving the device **14** on a prophylactic basis would be instructed to report each such episode to the attending physician for further evaluation of the patient's condition and assessment for the need for implantation of a more sophisticated ICD.

[0052] Subcutaneous device **14** desirably includes telemetry circuit (not shown in FIG. 2), so that it is capable of being programmed by means of external programmer **20** via a 2-way telemetry link (not shown). Uplink telemetry allows device status and diagnostic/event data to be sent to external programmer **20** for review by the patient's physician. Downlink telemetry allows the external programmer via physician control to allow the programming of device function and the optimization of the detection and therapy for a specific patient. Programmers and telemetry systems suitable for use in the practice of the present invention have been well known for many years. Known programmers typically communicate with an implanted device via a bi-directional radio-frequency telemetry link, so that the programmer can transmit control commands and operational parameter values to be received by the implanted device, so that the implanted device can communicate diagnostic and operational data to the programmer. Programmers believed to be suitable for the purposes of practicing the present invention include the Models 9790 and CareLink® programmers, commercially available from Medtronic, Inc., Minneapolis, Minn.

[0053] Various telemetry systems for providing the necessary communications channels between an external programming unit and an implanted device have been developed and are well known in the art. Telemetry systems believed to be suitable for the purposes of practicing the present invention are disclosed, for example, in the following U.S. Patents: U.S. Pat. No. 5, **127,404** to Wyborny et al. entitled "Telemetry Format for Implanted Medical Device"; U.S. Pat. No. 4,374,382 to Markowitz entitled "Marker Channel Telemetry System for a Medical Device"; and U.S. Pat. No. 4,556, **063** to Thompson et al. entitled "Telemetry

System for a Medical Device". The Wyborny et al. '404, Markowitz '382, and Thompson et al. '063 patents are commonly assigned to the assignee of the present invention, and are each hereby incorporated by reference herein in their respective entireties.

[0054] According to an embodiment of the present invention, in order to automatically select the preferred ECG vector set, it is necessary to have an index of merit upon which to rate the quality of the signal. "Quality" is defined as the signal's ability to provide accurate heart rate estimation and accurate morphological waveform separation between the patient's usual sinus rhythm and the patient's ventricular tachyarrhythmia.

[0055] Appropriate indices may include R-wave amplitude, R-wave peak amplitude to waveform amplitude between R-waves (i.e., signal to noise ratio), low slope content, relative high versus low frequency power, mean frequency estimation, probability density function, or some combination of these metrics.

[0056] Automatic vector selection might be done at implantation or periodically (daily, weekly, monthly) or both. At implant, automatic vector selection may be initiated as part of an automatic device turn-on procedure that performs such activities as measure lead impedances and battery voltages. The device turn-on procedure may be initiated by the implanting physician (e.g., by pressing a programmer button) or, alternatively, may be initiated automatically upon automatic detection of device/lead implantation. The turn-on procedure may also use the automatic vector selection criteria to determine if ECG vector quality is adequate for the current patient and for the device and lead position, prior to suturing the subcutaneous device **14** device in place and closing the incision. Such an ECG quality indicator would allow the implanting physician to maneuver the device to a new location or orientation to improve the quality of the ECG signals as required. The preferred ECG vector or vectors may also be selected at implant as part of the device turn-on procedure. The preferred vectors might be those vectors with the indices that maximize rate estimation and detection accuracy. There may also be an a priori set of vectors that are preferred by the physician, and as long as those vectors exceed some minimum threshold, or are only slightly worse than some other more desirable vectors, the a priori preferred vectors are chosen. Certain vectors may be considered nearly identical such that they are not tested unless the a priori selected vector index falls below some predetermined threshold.

[0057] Depending upon metric power consumption and power requirements of the device, the ECG signal quality metric may be measured on the range of vectors (or alternatively, a subset) as often as desired. Data may be gathered, for example, on a minute, hourly, daily, weekly or monthly basis. More frequent measurements (e.g., every minute) may be averaged over time and used to select vectors based upon susceptibility of vectors to occasional noise, motion noise, or EMI, for example.

[0058] Alternatively, the subcutaneous device **14** may have an indicator/sensor of patient activity (piezo-resistive, accelerometer, impedance, or the like) and delay automatic vector measurement during periods of moderate or high patient activity to periods of minimal to no activity. One representative scenario may include testing/evaluating ECG vectors once daily or weekly while the patient has been determined to be asleep (using an internal clock (e.g., 2:00

am) or, alternatively, infer sleep by determining the patient's position (via a 2- or 3-axis accelerometer) and a lack of activity).

[0059] If infrequent automatic, periodic measurements are made, it may also be desirable to measure noise (e.g., muscle, motion, EMI, etc.) in the signal and postpone the vector selection measurement when the noise has subsided.

[0060] Subcutaneous device **14** may optionally have an indicator of the patient's posture (via a 2- or 3-axis accelerometer). This sensor may be used to ensure that the differences in ECG quality are not simply a result of changing posture/position. The sensor may be used to gather data in a number of postures so that ECG quality may be averaged over these postures or, alternatively, selected for a preferred posture.

[0061] In the preferred embodiment, vector quality metric calculations would occur a number of times over approximately 1 minute, once per day, for each vector. These values would be averaged for each vector over the course of one week. Averaging may consist of a moving average or recursive average depending on time weighting and memory considerations. In this example, the preferred vector(s) would be selected once per week.

[0062] FIG. 3 is a state diagram of detection of arrhythmias in a medical device according to an embodiment of the present invention. As illustrated in FIG. 3, during normal operation, the device **14** is in a not concerned state **302**, during which R-wave intervals are being evaluated to identify periods of rapid rates and/or the presence of asystole. Upon detection of short R-wave intervals simultaneously in two separate ECG sensing vectors, indicative of an event that, if confirmed, may require the delivery of therapy, the device **14** transitions from the not concerned state **302** to a concerned state **304**. In the concerned state **304** the device **14** evaluates a predetermined window of ECG signals to determine the likelihood that the signal is corrupted with noise and to discriminate rhythms requiring shock therapy from those that do not require shock therapy, using a combination of R-wave intervals and ECG signal morphology information.

[0063] If a rhythm requiring shock therapy continues to be detected while in the concerned state **304**, the device **14** transitions from the concerned state **304** to an armed state **306**. If a rhythm requiring shock therapy is no longer detected while the device is in the concerned state **304** and the R-wave intervals are determined to no longer be short, the device **14** returns to the not concerned state **302**. However, if a rhythm requiring shock therapy is no longer detected while the device is in the concerned state **304**, but the R-wave intervals continue to be detected as being short, processing continues in the concerned state **304**.

[0064] In the armed state **306**, the device **14** charges the high voltage shocking capacitors and continues to monitor R-wave intervals and ECG signal morphology for spontaneous termination. If spontaneous termination of the rhythm requiring shock therapy occurs, the device **14** returns to the not concerned state **302**. If the rhythm requiring shock therapy is still determined to be occurring once the charging of the capacitors is completed, the device **14** transitions from the armed state **306** to a shock state **308**. In the shock state **308**, the device **14** delivers a shock and returns to the armed state **306** to evaluate the success of the therapy delivered.

[0065] The transitioning between the not concerned state **302**, the concerned state **304**, the armed state **306** and the

shock state **308** may be performed as described in detail in U.S. Pat. No. 7,894,894 to Stadler et al., incorporated herein by reference in its entirety.

[0066] FIG. 4 is a flowchart of a method for detecting arrhythmias in a subcutaneous device according to an embodiment of the present disclosure. As illustrated in FIG. 4, device **14** continuously evaluates the two channels ECG1 and ECG2 associated with two predetermined electrode vectors to determine when sensed events occur. For example, the electrode vectors for the two channels ECG1 and ECG2 may include a first vector (ECG1) selected between electrode **20** positioned on lead **16** and the housing or can **25** of ICD **14**, while the other electrode vector (ECG 2) is a vertical electrode vector between electrode **20** and electrode **22** positioned along the lead **16**. However, the two sensing channels may in any combination of possible vectors, including those formed by the electrodes shown in FIG. 2, or other additional electrodes (not shown) that may be included along the lead or positioned along the housing of ICD **14**.

[0067] According to an embodiment of the present application, for example, the device **14** determines whether to transition from the not concerned state **302** to the concerned state **304** by determining a heart rate estimate in response to the sensing of R-waves, as described in U.S. Pat. No. 7,894,894 to Stadler et al., incorporated herein by reference in its entirety.

[0068] Upon transition from the not concerned state to the concerned state, Block **305**, a most recent window of ECG data from both channels ECG1 and ECG2 are utilized, such as three seconds, for example, so that processing is triggered in the concerned state **304** by a three-second timeout, rather than by the sensing of an R-wave, which is utilized when in the not concerned state **302**. It is understood that while the processing is described as being triggered over a three second period, other times periods for the processing time utilized when in the concerned state **304** may be chosen, but should preferably be within a range of 0.5 to 10 seconds. As a result, although sensing of individual R-waves continues to occur in both channels ECG1 and ECG2 when in the concerned state **304**, and the buffer of 12 R-R intervals continues to be updated, the opportunities for changing from the concerned state **304** to another state and the estimates of heart rate only occur once the three-second timer expires. Upon initial entry to the concerned state **304**, it is advantageous to process the most recent three-seconds of ECG data, i.e., ECG data for the three seconds leading up to the transition to the concerned state **304**. This requires a continuous circular buffering of the most recent three seconds of ECG data even while in the not concerned state **302**.

[0069] While in the concerned state **304**, the present invention determines how sinusoidal and how noisy the signals are in order to determine the likelihood that a ventricular fibrillation (VF) or fast ventricular tachycardia (VT) event is taking place, since the more sinusoidal and low noise the signal is, the more likely a VT/VF event is taking place. As illustrated in FIG. 4, once the device transitions from the not concerned state **302** to the concerned state **304**, Block **305**, a buffer for each of the two channels ECG 1 and ECG2 for storing classifications of 3-second segments of data as “shockable” or “non-shockable” is cleared. Processing of signals of the two channels ECG1 and ECG2 while in the concerned state **304** is then triggered by

the three second time period, rather than by the sensing of an R-wave utilized during the not concerned state **302**.

[0070] Once the three second time interval has expired, YES in Block **341**, morphology characteristics of the signal during the three second time interval for each channel are utilized to determine whether the signals are likely corrupted by noise artifacts and to characterize the morphology of the signal as “shockable” or “not shockable”. For example, using the signals associated with the three second time interval, a determination is made for each channel ECG1 and ECG 2 as to whether the channel is likely corrupted by noise, Block **342**, and a determination is then made as to whether both channels ECG1 and ECG2 are corrupted by noise, Block **344**.

[0071] FIG. 5 is a flowchart of a method of determining noise according to an embodiment of the present disclosure. As illustrated in FIG. 5, the determination as to whether the signal associated with each of the channels ECG1 and ECG2 is likely corrupted by noise, Block **342** of FIG. 4, includes multiple sequential noise tests that are performed on each channel ECG and ECG2. During a first noise test, for example, a determination is made as to whether a metric of signal energy content of the signal for the channel is within predetermined limits, Block **380**. For example, the amplitude of each sample associated with the three second window is determined, resulting in N sample amplitudes, from which a mean rectified amplitude is calculated as the ratio of the sum of the rectified sample amplitudes to the total number of sample amplitudes N for the segment. If the sampling rate is 256 samples per second, for example, the total number of sample amplitudes N for the three-second segment would be N=768 samples.

[0072] Once the mean rectified amplitude is calculated, a determination is made as to whether the mean rectified amplitude is between an upper average amplitude limit and a lower average amplitude limit, the lower average amplitude limit being associated with asystole episodes without artifact and the upper average amplitude limit being associated with a value greater than what would be associated with ventricular tachycardia and ventricular fibrillation events. According to an embodiment of the present invention, the upper average amplitude limit is set as 1.5 mV, and the lower average amplitude limit is set as 0.013 mV. While the metric of signal energy content is described above as the mean rectified amplitude, it is understood that other signal of energy contents could be utilized.

[0073] If the determined mean rectified amplitude is not between the upper average amplitude limit and the lower average amplitude limit, the three second segment for that channel is identified as being likely corrupted with noise, Block **386**, and no further noise tests are initiated for that channel's segment.

[0074] If the determined mean rectified amplitude is located between the upper average amplitude limit and the lower average amplitude limit, a noise to signal ratio is calculated and a determination is made as to whether the noise to signal ratio is less than a predetermined noise to signal threshold, Block **382**. For example, the amplitude of each sample associated with the three second window is determined, resulting in N raw sample amplitudes. The raw signal is lowpass filtered, resulting in L lowpass sample amplitudes. The raw mean rectified amplitude is determined as the average of the absolute values of the raw sample amplitudes. The lowpass mean rectified amplitude is deter-

mined as the average of the absolute values of the lowpass sample amplitudes. Next, a highpass mean rectified amplitude is then calculated as the difference between the raw mean rectified amplitude and the lowpass mean rectified amplitude. The noise to signal ratio is then determined as the ratio of the highpass mean rectified amplitude to the lowpass mean rectified amplitude. If the noise to signal ratio is greater than a predetermined threshold, such as **0.0703**, for example, the three second segment for that channel is identified as being likely corrupted with noise, Block **386**, and no further noise tests are initiated for the segment.

[0075] If the noise to signal ratio is less than or equal to the predetermined threshold, a determination is made as to whether the signal is corrupted by muscle noise, Block **384**. According to an embodiment of the present invention, the determination as to whether the signal is corrupted by muscle noise is made by determining whether the signal includes a predetermined number of signal inflections indicative of the likelihood of the signal being corrupted by muscle noise, using a muscle noise pulse count that is calculated to quantify the number of signal inflections in the three second interval for each channel **ECG1** and **ECG2**. The presence of a significant number of inflections is likely indicative of muscle noise.

[0076] FIG. **6A** is a graphical representation of a determination of whether a signal is corrupted by muscle noise according to an embodiment of the present invention. FIG. **6B** is a flowchart of a method of determining whether a signal is corrupted by muscle noise according to an embodiment of the present invention. For example, as illustrated in FIGS. **6A** and **6B**, in order to determine a muscle noise count for the three second interval, the raw signal **420** is applied to a first order derivative filter to obtain a derivative signal **422**, and all of the zero-crossings **424** in the derivative signal **422** are located, Block **460**. A data pair corresponding to the data points immediately prior to and subsequent to the zero crossings **424**, points **426** and **428** respectively, for each crossing is obtained. The value of the data point in each data pair with smaller absolute value is zeroed in order to allow a clear demarcation of each pulse when a rectified signal **430** is derived from the derivative signal **422** with zeroed zero-crossing points **432**.

[0077] A pulse amplitude threshold T_d , for determining whether the identified inflection is of a significant amplitude to be identified as being associated with muscle noise, is determined, Block **462**, by dividing the rectified signal from the three second segment into equal sub-segments **434**, estimating a local maximum amplitude **436-442** for each of the sub-segments **434**, and determining whether the local amplitudes **436-442** are less than a portion of the maximum amplitude, which is maximum amplitude **440** in the example of FIG. **6A**, for the whole three second segment. If the local maximum amplitude is less than the portion of the maximum amplitude for the whole three second segment, the local maximum amplitude is replaced by the maximum for the whole three second segment for the sub-segment corresponding to that local maximum amplitude.

[0078] It is understood that while only two or less zero-crossing points are shown as being located within the sub-segments in the illustration of FIG. **6A** for the sake of simplicity, in fact each of the sub-segments **434**, which have a length of approximately 750 milliseconds, will contain many inflections, such as every 25 milliseconds, for example.

[0079] According to an embodiment of the present invention, the three second segment is divided into four sub-segments and the local maximum amplitudes are replaced by the maximum amplitude for the whole segment if the local maximum amplitude is less than one fifth of the maximum amplitude for the whole segment. Once the determination of whether to replace the local maximum amplitudes for each of the sub-segments with the maximum amplitude for the whole segment is completed, the pulse amplitude threshold T_d for the segment is set equal to a predetermined fraction of the mean of the local maximum amplitudes for each of the sub-segments. According to an embodiment of the present invention, the pulse amplitude threshold T_d for the three second segment is set equal to one sixth of the mean of the local maximum amplitudes **436-440**.

[0080] Once the pulse amplitude threshold T_d has been determined, the inflections associated with the signal for the three second segment is classified as being of significant level to be likely indicative of noise by determining whether the pulse amplitude threshold T_d is less than a pulse threshold, Block **464**. According to an embodiment of the present invention, the pulse threshold is set as 1 microvolt. If the pulse amplitude threshold T_d is less than the pulse threshold, the signal strength is too small for a determination of muscle noise, and therefore the signal is determined to be not likely corrupted by noise and therefore the channel is determined to be not noise corrupted, Block **466**.

[0081] If the pulse amplitude threshold T_d is greater than or equal to the pulse threshold, the three second segment is divided into twelve sub-segments of 250 ms window length, the number of muscle noise pulses in each sub-segment is counted, and both the sub-segment having the maximum number of muscle noise pulses and the number of sub-segments having 6 or more muscle noise pulses that are greater than a predetermined minimum threshold is determined. Muscle noise is determined to be present in the signal if either the maximum number of muscle noise pulses in a single sub-segment is greater than a noise pulse number threshold or the number of sub-segments of the twelve sub-segments having 6 or more muscle noise pulses greater than the minimum threshold is greater than or equal to a sub-segment pulse count threshold. According to an embodiment of the present invention, the noise pulse number threshold is set equal to eight and the sub-segment pulse count threshold is set equal to three.

[0082] For example, if the pulse amplitude threshold T_d is greater than or equal to the pulse threshold, No in Block **464**, the maximum number of muscle noise counts in a single sub-segment is determined, Block **468**. If the maximum number of muscle noise counts is greater than the noise pulse number threshold, Yes in Block **470**, the channel is determined to be noise corrupted, Block **472**. If the maximum number of muscle noise counts for the channel is less than or equal to the noise pulse number threshold, No in Block **470**, the number of sub-segments of the twelve sub-segments having 6 or more muscle noise pulses greater than the minimum threshold is determined, Block **474**, and if the number is greater than or equal to a sub-segment pulse count threshold, Yes in Block **476**, the channel is determined to be noise corrupted, Block **472**. If the number is less than the sub-segment pulse count threshold, No in Block **476**, the channel is determined not to be noise corrupted, Block **466**.

[0083] FIG. **6C** is a flowchart of a method of determining whether a signal is corrupted by muscle noise according to

an embodiment of the present invention. Since muscle noise can be present during an episode of ventricular tachycardia, the width of the overall signal pulse waveform is determined in order to distinguish between signals that are determined likely to be purely noise related and signals that are both shockable events and determined to include noise. Therefore, as illustrated in FIG. 6C, according to an embodiment of the present invention, once muscle noise is determined to be present as a result of the muscle noise pulse count being satisfied, No in Block 470 and Yes in Block 476, a determination is made as to whether the signal is both noise corrupted and shockable, Block 480.

[0084] According to an embodiment of the present invention, the determination in Block 480 as to whether the signal is both noisy and shockable is made, for example, by dividing the rectified signal, having 768 data points, into four sub-segments and determining a maximum amplitude for each of the four sub-segments by determining whether a maximum amplitude for the sub-segment is less than a portion of the maximum amplitude for the entire rectified signal in the three second segment. For example, a determination is made for each sub-segment as to whether the maximum amplitude for the sub-segment is less than one fourth of the maximum amplitude for the entire rectified signal. If less than a portion of the maximum amplitude for the entire rectified signal in the three second segment, the maximum amplitude for the sub-segment is set equal to the maximum amplitude for the entire rectified signal.

[0085] A mean rectified amplitude for each of the sub-segments is determined by dividing the sum of the rectified amplitudes for the sub-segment by the number of samples in the sub-segment, i.e., $768/4$. Then the normalized mean rectified amplitude for each sub-segment is determined by dividing the mean rectified amplitude for each of the sub-segments by the peak amplitude for the sub-segment. The normalized mean rectified amplitude for the three second segment is then determined as the sum of the normalized mean rectified amplitudes for each sub-segment divided by the number of sub-segments, i.e., four.

[0086] Therefore, once muscle noise is suspected as a result of the determination of the muscle noise pulse count, the determination of Block 480 based on whether the normalized mean rectified amplitude for the three second segment is greater than a predetermined threshold for identifying signals that, despite being indicative of a likelihood of being associated with noise, nevertheless are associated with a shockable event. For example, according to an embodiment of the present invention, a determination is made as to whether the normalized mean rectified amplitude for the three second segment is greater than 18 microvolts. If the normalized mean rectified amplitude for the three second segment is less than or equal to the predetermined threshold, the channel is likely corrupted by muscle noise and not shockable, No in Block 480, and is therefore identified as being corrupted by noise, Block 472. If the normalized mean rectified amplitude for the three second segment is greater than the predetermined threshold, the channel is determined to be likely corrupted by muscle noise and shockable, Yes in Block 480, and is therefore identified as not to be likely corrupted by muscle noise, Block 478.

[0087] Returning to FIG. 5, when the signal is determined to be not likely corrupted by muscle noise, a determination is made as to whether the mean frequency of the signal associated with the channel is less than a predetermined

mean frequency threshold, Block 388, such as 11 Hz for example. The mean frequency of the signal during the 3 second segment for each channel ECG 1 and ECG2 is generated, for example, by calculating the ratio of the mean absolute amplitude of the first derivative of the 3 second segment to the mean absolute amplitude of the 3 second segment, multiplied by a constant scaling factor. If the mean frequency is determined to be greater than or equal to the predetermined mean frequency threshold, No in Block 388, the three second segment for that channel is identified as being likely corrupted with noise, Block 386. If the mean frequency is determined to be less than the predetermined mean frequency threshold, Yes in Block 388, the three second segment for that channel is identified as being not noise corrupted, Block 390.

[0088] According to an embodiment of the present invention, since the mean spectral frequency tends to be low for true ventricular fibrillation events, moderate for organized rhythms such as sinus rhythm and supraventricular tachycardia, for example, and high during asystole and noise, the determination in Block 388 includes determining whether the mean frequency is less than a predetermined upper mean frequency threshold, such as 11 Hz (i.e., mean period T of approximately 91 milliseconds) for example, and whether the mean frequency is less than a predetermined lower mean frequency, such as 3 Hz for example. If the mean frequency is below a second, lower threshold, such as 3 Hz, for example, the signal is also rejected as noise and no further noise tests are initiated. This comparison of the mean frequency to a second lower threshold is intended to identify instances of oversensing, resulting in appropriate transition to the concerned state. If the mean frequency of the signal is less than 3 Hz, it is generally not possible for the heart rate to be greater than 180 beats per minute. In practice, it may be advantageous to set the lower frequency threshold equal to the programmed VT/VF detection rate, which is typically approximately 3 Hz.

[0089] Therefore, in the determination of Block 388, if the mean frequency is determined to be either greater than or equal to the predetermined upper mean frequency threshold or less than the lower threshold, the three second segment for that channel is identified as being likely corrupted with noise, Block 386. If the mean frequency is determined to be both less than the predetermined upper mean frequency threshold and greater than the lower threshold, the three second segment for that channel is identified as not being noise corrupted, Block 390.

[0090] Returning to FIG. 4, once the determination as to whether the channels ECG1 and ECG2 are corrupted by noise is made, Block 342, a determination is made as to whether both channels are determined to be noise corrupted, Block 344. If the signal associated with both channels ECG1 and ECG2 is determined to likely be corrupted by noise, both channels are classified as being not shockable, Block 347, and therefore a buffer for each channel ECG1 and ECG 2 containing the last three classifications of the channel is updated accordingly and the process is repeated for the next three-second windows. If both channels ECG1 and ECG2 are not determined to be likely corrupted by noise, No in Block 344, the device distinguishes between either one of the channels being not corrupted by noise or both channels being not corrupted by noise by determining whether noise was determined to be likely in only one of the two channels ECG1 and ECG2, Block 346.

[0091] If noise was likely in only one of the two channels, a determination is made whether the signal for the channel not corrupted by noise, i.e., the clean channel, is more likely associated with a VT event or with a VF event by determining, for example, whether the signal for that channel includes R-R intervals that are regular and the channel can be therefore classified as being relatively stable, Block **348**. If the R-R intervals are determined not to be relatively stable, NO in Block **348**, the signal for that channel is identified as likely being associated with VF, which is then verified by determining whether the signal is in a VF shock zone, Block **350**, described below. If R-R intervals for that channel are determined to be stable, YES in Block **348**, the signal is identified as likely being associated with VT, which is then verified by determining whether the signal is in a VT shock zone, Block **352**, described below.

[0092] If noise was not likely for both of the channels, No in Block **346**, i.e., both channels are determined to be clean channels, a determination is made whether the signal for both channels is more likely associated with a VT event or with a VF event by determining whether the signal for both channels includes R-R intervals that are regular and can be therefore classified as being relatively stable, Block **356**. The determination in Block **356** of whether the R-R intervals are determined to be relatively stable may be made using the method described in U.S. Pat. No. 7,894,894 to Stadler et al., incorporated herein by reference in its entirety. If the R-R intervals are determined not to be relatively stable, NO in Block **356**, the signal for both channels is identified as likely being associated with VF, which is then verified by determining whether the signal for each channel is in a VF shock zone, Block **360**, described below. If R-R intervals for both channels are determined to be stable, YES in Block **356**, the signal is identified as likely being associated with VT, which is then verified by determining, based on both channels, whether the signal is in a VT shock zone, Block **358**.

[0093] FIG. 7 is a graphical representation of a VF shock zone according to an embodiment of the present invention. As illustrated in FIG. 7, a VF shock zone **500** is defined for each channel ECG1 and ECG2 based on the relationship between the calculated low slope content and the spectral width associated with the channel. For example, the shock zone is defined by a first boundary **502** associated with the low slope content set for by the equation:

$$\text{Low slope content} = -0.0013 \times \text{spectral width} + 0.415 \quad \text{Equation 1}$$

and a second boundary **504** associated with the spectral width set forth by the equation:

$$\text{spectral width} = 200 \quad \text{Equation 2}$$

[0094] The low slope content metric is calculated as the ratio of the number of data points with low slope to the total number of samples in the 3-second segment. For example, according to an embodiment of the present invention, the difference between successive ECG samples is determined as an approximation of the first derivative (i.e., the slope) of the ECG signal. In particular, the raw signal for each channel is applied to a first order derivative filter to obtain a derivative signal for the three-second segment. The derivative signal is then rectified, divided into four equal sub-segments, and the largest absolute slope is estimated for each of the four sub-segments.

[0095] A determination is made as to whether the largest absolute slopes are less than a portion of the overall largest absolute slope for the whole three-second segment, such as

one-fifth of the overall absolute slope, for example. If the largest absolute slope is less than the portion of the overall slope, then the slope value for that sub-segment is set equal to the overall largest absolute slope. If the largest absolute slope is not less than the portion of the overall slope, then the slope value for that sub-segment is set equal to the determined largest absolute slope for the sub-segment.

[0096] Once the slope value for each of the sub-segments has been determined and updated by being set equal to the largest slope for the three second segment, if necessary, the average of the four slopes is calculated and divided by a predetermined factor, such as 16 for example, to obtain a low slope threshold. The low slope content is then obtained by determining the number of sample points in the three-second segment having an absolute slope less than or equal to the low slope threshold.

[0097] According to an embodiment of the present invention, if, during the determination of the low slope threshold, the low slope threshold is a fraction, rather than a whole number, a correction is made to the low slope content to add a corresponding fraction of the samples. For example, if the threshold is determined to be 4.5, then the low slope content is the number of sample points having an absolute slope less than or equal to 4 plus one half of the number of sample points with slope equal to 5.

[0098] The spectral width metric, which corresponds to an estimate of the spectral width of the signal for the three-second segment associated with each channel ECG1 and ECG2, is defined, for example, as the difference between the mean frequency and the fundamental frequency of the signal. According to an embodiment of the present invention, the spectral width metric is calculated by determining the difference between the most recent estimate of the RR-cycle length and the mean spectral period of the signal for that channel. As is known in the art, the mean spectral period is the inverse of the mean spectral frequency.

[0099] As can be seen in FIG. 7, since noise **506** tends to have a relatively higher spectral width, and normal sinus rhythm **508** tends to have a relatively higher low slope content relative to VF, both noise **506** and normal sinus rhythm **508** would be located outside the VF shock zone **500**.

[0100] A determination is made for each channel ECG1 and ECG2 as to whether the low slope content for that channel is less than both the first boundary **502** and the spectral width is less than the second boundary **504**, i.e., the low slope content is less than $-0.0013 \times \text{spectral width} + 0.415$, and the spectral width is less than 200. For example, once the event is determined to be associated with VF, i.e., the intervals for both channels are determined to be irregular, No in Block **356**, a determination is made that channel ECG1 is in the VF shock zone, Yes in Block **360**, if, for channel ECG1, both the low slope content is less than the first boundary **502** and the spectral width is less than the second boundary **504**. The three second segment for that channel ECG1 is then determined to be shockable, Block **363** and the associated buffer for that channel is updated accordingly. If either the low slope content for the channel is not less than the first boundary **502** or the spectral width is not less than the second boundary, the channel ECG1 is determined not to be in the VF shock zone, No in Block **360**, the three second segment for that channel ECG1 is then determined to be not shockable, Block **365**, and the associated buffer is updated accordingly.

[0101] Similarly, a determination is made that channel ECG2 is in the VF shock zone, Yes in Block 362, if, for channel ECG2, both the low slope content is less than the first boundary 502 and the spectral width is less than the second boundary 504. The three second segment for that channel ECG2 is then determined to be shockable, Block 369 and the associated buffer for that channel is updated accordingly. If either the low slope content for the channel is not less than the first boundary 502 or the spectral width is not less than the second boundary, the channel ECG2 is determined not to be in the VF shock zone, No in Block 362, the three second segment for that channel ECG2 is then determined to be not shockable, Block 367, and the associated buffer is updated accordingly.

[0102] FIGS. 8A and 8B are graphical representations of the determination of whether an event is within a shock zone according to an embodiment of the present invention. During the determination of whether the event is within the VT shock zone, Block 358 of FIG. 4, the low slope content and the spectral width is determined for each channel ECG1 and ECG2, as described above in reference to determining the VF shock zone. A determination is made as to which channel of the two signal channels ECG1 and ECG2 contains the minimum low slope content and which channel of the two signal channels ECG 1 and ECG2 contains the minimum spectral width. A first VT shock zone 520 is defined based on the relationship between the low slope content associated with the channel determined to have the minimum low slope content and the spectral width associated with the channel determined to have the minimum spectral width. For example, according to an embodiment of the present invention, the first VT shock zone 520 is defined by a boundary 522 associated with the minimum low slope content and the minimum spectral width set forth by the equation:

$$LSC = -0.004 \times SW + 0.93 \quad \text{Equation 3}$$

[0103] A second VT shock zone 524 is defined based on the relationship between the low slope content associated with the channel determined to have the minimum low slope content and the normalized mean rectified amplitude associated with the channel determined to have the maximum normalized mean rectified amplitude. In order to determine the normalized mean rectified amplitudes for the two channels ECG1 and ECG2 utilized during the VT shock zone test, the amplitude of each sample associated with the three second window is determined, resulting in N sample amplitudes, from which a mean rectified amplitude is calculated as the ratio of the sum of the rectified sample amplitudes to the total number of sample amplitudes N for the segment. If the sampling rate is 256 samples per second, for example, the total number of sample amplitudes N for the three-second segment would be N=768 samples.

[0104] According to an embodiment of the present invention, for example, the second VT shock zone 524 is defined by a second boundary 526 associated with the relationship between the minimum low slope count and the maximum normalized mean rectified amplitude set forth by the equation:

$$NMRA = 68 \times LSC + 8.16 \quad \text{Equation 4}$$

[0105] If both the minimum low slope count is less than the first boundary 522, i.e., $-0.004 \times \text{minimum spectral width} + 0.93$, and the maximum normalized mean rectified amplitude is greater than the second boundary 526, i.e., $68 \times \text{minimum low slope count} + 8.16$, the event is determined

to be in the VT shock zone, YES in Block 358, and both channels ECG1 and ECG2 are determined to be shockable, Block 357, and the associated buffers are updated accordingly. If either the minimum low slope count is not less than the first boundary 522 or the maximum normalized mean rectified amplitude is not greater than the second boundary 526, the event is determined to be outside the VT shock zone, NO in Block 358, and both channels ECG1 and ECG2 are determined to be not shockable, Block 359.

[0106] As described, during both the VF shock zone test, Blocks 360 and 362, and the VT shock zone test, Block 358, the test results for each channel ECG1 and ECG2 as being classified as shockable or not shockable are stored in a rolling buffer containing the most recent eight such designations, for example, for each of the two channels ECG1 and ECG2 that is utilized in the determination of Block 356, as described below.

[0107] If only one of the two channels ECG1 and ECG2 is determined to be corrupted by noise, Yes in Block 346, a determination is made whether the signal for the channel not corrupted by noise, i.e., the “clean channel”, is more likely associated with a VT event or with a VF event by determining whether the signal for the clean channel includes R-R intervals that are regular and can be therefore classified as being relatively stable, Block 348. If the R-R intervals are determined not to be relatively stable, NO in Block 348, the signal for the clean channel is identified as likely being associated with VF, which is then verified by determining whether the signal for the clean channel is in a VF shock zone, Block 350, described below. If R-R intervals for the clean channel are determined to be stable, YES in Block 348, the signal is identified as likely being associated with VT, which is then verified by determining whether the signal for the clean channel is in a VT shock zone, Block 352.

[0108] According to an embodiment of the present invention, in order to determine whether the signal for the clean channel includes R-R intervals that are regular and the clean channel can be therefore classified as being either relatively stable, Yes in Block 348, or relatively unstable, No in Block 348, the device discriminates VT events from VF events in Block 348 by determining whether the relative level of variation in the RR-intervals associated with the clean channel is regular. FIG. 9 is a flowchart of a method for discriminating cardiac events according to an embodiment of the disclosure. For example, as illustrated in FIG. 9, predetermined maximum and minimum intervals for the clean channel are identified from the updated buffer of 12 RR-intervals, Block 342 of FIG. 4. According to an embodiment of the present invention, the largest RR-interval and the sixth largest RR-interval of the twelve RR-intervals are utilized as the maximum interval and the minimum interval, respectively.

[0109] The difference between the maximum RR-interval and the minimum RR-interval of the 12 RR-intervals is calculated to generate an interval difference associated with the clean channel, 702. A determination is then made as to whether the interval difference is greater than a predetermined stability threshold, Block 704, such as 110 milliseconds, for example.

[0110] If the interval difference is greater than the stability threshold, the event is classified as an unstable event, Block 706, and therefore the clean channel is determined not to include regular intervals, No in Block 348, and a determination is made as to whether the signal associated with the

clean channel is within a predetermined VF shock zone, Block 350 of FIG. 4, described below. If the interval difference is less than or equal to the stability threshold, No in Block 704, the device determines whether the minimum RR interval is greater than a minimum interval threshold, Block 710, such as 200 milliseconds, for example.

[0111] If the minimum interval is less than or equal to the minimum interval threshold, No in Block 710, the event is classified as an unstable event, Block 706, and therefore the clean channel is determined not to include regular intervals, No in Block 348, and a determination is made as to whether the signal associated with the clean channel is within a predetermined VF shock zone, Block 350 of FIG. 4, described below. If the minimum interval is greater than the minimum interval threshold, Yes in Block 710, the device determines whether the maximum interval is less than or equal to a maximum interval threshold, Block 712, such as 333 milliseconds for example. If the maximum interval is greater than the maximum interval threshold, the event is classified as an unstable event, Block 706, and therefore the clean channel is determined not to include regular intervals, No in Block 348, and a determination is made as to whether the signal associated with the clean channel is within a predetermined VF shock zone, Block 350 of FIG. 4, described below. If the maximum interval is less than or equal to the maximum interval threshold, the event is classified as a stable event, Block 714, and therefore the clean channel is determined to include regular intervals, Yes in Block 348, and a determination is made as to whether the signal associated with the clean channel is within a predetermined VT shock zone, Block 352 of FIG. 4, described below.

[0112] Returning to FIG. 4, the determination of whether the clean channel is within the VF shock zone, Block 350, is made based upon a low slope content metric and a spectral width metric, similar to the VF shock zone determination described above in reference to Blocks 360 and 362, both of which are determined for the clean channel using the method described above. Once the low slope content metric and a spectral width metric are determined for the clean channel, the determination of whether the clean channel is in the VF shock zone is made using Equations 1 and 2, so that if either the low slope content for the clean channel is not less than the first boundary 502 or the spectral width is not less than the second boundary 504, the clean channel is determined not to be in the VF zone, No in Block 350 and both channels are classified as not shockable, Block 351, and the associated buffers are updated accordingly.

[0113] If the low slope content for the clean channel is less than the first boundary 502 and the spectral width is less than the second boundary 504, the clean channel is determined to be in the VF zone, Yes in Block 350. A determination is then made as to whether the channel determined to be corrupted by noise, i.e., the “noisy channel”, is within the VF shock zone, Block 354. If either the low slope content for the noisy channel is not less than the first boundary 502 or the spectral width is not less than the second boundary 504, the noisy channel is determined not to be in the VF zone, No in Block 354, the clean channel is classified as shockable and the noisy channel is classified as not shockable, Block 355, and the associated buffers are updated accordingly.

[0114] If the low slope content for the noisy channel is less than the first boundary 502 and the spectral width is less than the second boundary 504, the noisy channel is determined to

be in the VF zone, Yes in Block 354, both the clean channel and the noisy channel are classified as being shockable, Block 353, and the associated buffers are updated accordingly.

[0115] Similar to the VT shock zone determination described above in reference to Block 358, during the determination as to whether the clean channel is within the VT shock zone in Block 352, the low slope content and the spectral width is determined for the clean channel as described above in reference to determining the VF shock zone. The first VT shock zone 520 is defined based on the relationship between the low slope content and the spectral width associated with the clean channel according to Equation 3, for example, and the second VT shock zone 524 is defined based on the relationship between the low slope count and the normalized mean rectified amplitude associated with the clean channel. The normalized mean rectified amplitudes for the clean channel is the same as described above in reference to the noise detection tests of Block 344. For example, according to an embodiment of the present invention, the second VT shock zone 524 is defined by a second boundary 526 associated with the relationship between the low slope count and the normalized mean rectified amplitude of the clean channel using Equation 4.

[0116] If both the low slope count is less than the first boundary 522, i.e., $-0.004 \times \text{spectral width of clean channel} + 0.93$, and the normalized mean rectified amplitude is greater than the second boundary 526, i.e., $68 \times \text{low slope count of clean channel} + 8.16$, the clean channel is determined to be in the VT shock zone, Yes in Block 352, both channels are classified as being shockable, Block 353, and the associated buffers are updated accordingly.

[0117] If either the low slope count is not less than the first boundary 522 or the maximum normalized mean rectified amplitude is not greater than the second boundary 526, the clean channel is determined to be outside the VT shock zone, No in Block 352, both channels are classified as being not shockable, Block 351, and the associated buffers are updated accordingly.

[0118] According to an embodiment of the present disclosure, in addition to the classification of the sensing channels ECG1 and ECG2 as being shockable or not shockable using a gross morphology analysis, as described in FIG. 4, for example, the device also determines whether periodic normal beats are detected for one or both of the sensing channels, ECG1 and ECG2, Block 368. As a result, the decision on state transitions (e.g. as to whether to transition from the concerned operating state 304 to the armed operating state 306 in Block 370, or from the armed state 306 to the shock state 308) is made based on the results of both an analysis of the gross morphology of the signal in the three-second window or windows for each sensing channel ECG1 and ECG2, and a determination of whether periodic normal beats occur within one or more of the three-second windows for one or both sensing channel ECG1 and ECG2, as described below. For a three-second segment to be classified as shockable, both the gross morphology and periodic normal beats analysis have to classify the same three-second segment as being shockable.

[0119] For example, according to an embodiment of the present invention, in order to determine whether to transition from the concerned operating state 304 to the armed operating state 306, the device determines whether a predetermined number, such as two out of three for example, of

three-second segments for both channels ECG1 and ECG2 have been classified as being shockable during the gross morphology analysis, Blocks 353, 357, 363 and 369, and determines whether periodic normal beats have been determined to occur for one or more of the three-second segments for the channels, Block 368. If the predetermined number of three-second segments in both channels ECG1 and ECG2 have been classified as shockable during both the gross morphology analysis and the periodic normal beats detection, the device transitions from the concerned state 304 to the armed state 306, Yes in Block 370. When the device determines to transition from the concerned state 304 to the armed state 306, Yes in Block 370, processing continues to be triggered by a three-second time out as is utilized during the concerned state 304, described above.

[0120] If the predetermined number of three-second segments in both channels ECG1 and ECG2 have not been classified as shockable during both the gross morphology analysis and the periodic normal beats detection, the device does not transition from the concerned state 304 to the armed state 306, No in Block 370, and a determination as to whether to transition back to the not concerned state 302 is made, Block 372. The determination as to whether to transition from the concerned state 304 back to the not concerned state 302 is made, for example, by determining whether a heart rate estimate is less than a heart rate threshold level in both of the two channels ECG1 and ECG2, using the method for determining a heart rate estimate as described in U.S. Pat. No. 7,894,894 to Stadler et al., incorporated herein by reference in its entirety. If it is determined that the device should not transition to the not concerned state 302, i.e., either of the two heart rate estimates are greater than the heart rate threshold, No in Block 372, the process continues using the signal generated during a next three-second window, Block 341.

[0121] FIG. 10 is a flowchart of a method for performing periodic normal beats analysis during detection of arrhythmias in a medical device, according to an embodiment of the present disclosure. Therefore, as described above, in addition to performing the morphology analysis of the whole waveform within the three-second windows associated with each sensing channel ECG1 and ECG2, the device determines whether periodic normal beats are detected within the sensing channels ECG1 and ECG2, Block 368 of FIG. 4. In particular, as illustrated in FIG. 10, for each three-second sensing window associated with the respective sensing channels ECG1 and ECG2, the device locates a single beat, i.e., R-wave, of the multiple beats in the three-second window, Block 720, and performs a beat-based analysis of the single beat, Block 722. According to an embodiment, for example, during the beat-based analysis, Block 722, the device computes a normalized waveform area difference (NWAD) between the beat, also identified herein as “the unknown beat”, and a predetermined beat template, such as a normal sinus rhythm template, for example, and determines whether the beat matches the template, Block 724, based on the determined normalized waveform area difference, as described below.

[0122] Using the results of the comparison of the beat to the template, the device determines whether the beat is either a match beat or a non-match beat, Block 724, by determining whether the beat matches the sinus rhythm template within a predetermined percentage, such as 60 percent, for example. If the beat matches the template by the predeter-

mined percentage or greater, Yes in Block 724, the beat is identified as a match beat, Block 726. If the beat matches the template by less than the predetermined percentage, No in Block 724, the beat is identified as a non-match beat, Block 728.

[0123] FIG. 11 is a flowchart of a method for aligning an ECG signal of an unknown beat with a known morphology template for beat-based analysis during detection of arrhythmias in a medical device, according to an embodiment of the present disclosure. In order to perform the comparison of the unknown beat with the template in Block 724 of FIG. 10 to identify the beat as being either a match beat or a non-match beat, the unknown beat must be aligned with the template. As illustrated in FIG. 11, during alignment of the unknown beat with the template, Block 800, the device identifies individual beats within the three-second window based on determined R-wave sense signals, Block 802, and for each beat stores n points before and n points after the sample point on which the R-wave sense occurs. The $2n + 1$ sample points define an alignment window within which an alignment point will be identified for alignment with the clinician input or device generated template, such as a normal sinus rhythm template, for example. In one embodiment, the alignment window is 53 sample points centered on the R-wave sense point. These sample points are stored in a memory buffer at block 804.

[0124] Once the sample points are determined for the beat, the device determines a fourth order difference signal for the beat from the buffered signal sample data, Block 806. The maximum slope of the fourth order difference signal is determined and compared to a maximum slope threshold, e.g. approximately 136 analog-to-digital (A/D) conversion units, Block 808. If the slope threshold is not met, No in Block 808, the signal may be rejected as a weak signal, no further analysis of that beat is performed, and the process continues with the next beat in the three-second window, Block 802. If the maximum slope is greater than the threshold, Yes in Block 808, indicating that at least one pulse corresponding to an R-wave is likely to be present in the alignment window, pulses associate with the individual beat within the alignment window are identified, Block 810.

[0125] To identify pulses associated with the beat within the alignment window, pulse criteria may be established, such as having a pulse width equal to at least some minimum number of sample points and a pulse amplitude of at least some minimum amplitude. The number of pulses identified, or lack thereof, within the alignment window may be used to reject a “cardiac cycle” as a noisy cycle or a weak signal. One or more pulses, including negative-going and positive-going pulses, may be identified according to amplitude and pulse width criteria. In some examples, a pulse may be identified based on a slope, maximum peak amplitude (positive or negative), pulse width or any combination thereof. If a threshold number of pulses is identified within the alignment window, the cycle may be considered a noisy cycle. While not shown explicitly in FIG. 11, a noisy cycle may be flagged or rejected for use in morphology analysis.

[0126] After identifying all pulses from the fourth order difference signal in the alignment window, a pulse having a maximum pulse amplitude and having the same polarity as a stored template alignment point is identified, Block 812. The sample point having the maximum pulse amplitude (absolute value) that also matches the polarity of the tem-

plate alignment point is identified and defined as the unknown signal alignment point.

[0127] An alignment shift is computed, Block 814, as the difference in sample point number between the alignment point identified, Block 812, and the previously established template alignment point. The alignment shift is the number of sample points, that the unknown beat must be shifted in order to align the unknown signal alignment point with the template alignment point. The alignment shift is applied by shifting the unknown beat sample points to align the unknown beat and the template over the alignment window, Block 816. The alignment shift may be applied to the fourth order difference signal itself if the template is stored as an ensemble average of aligned fourth order difference signals or stored as the fourth order difference signal of an ensemble average of aligned raw ECG signals. The alignment shift may additionally or alternatively be applied to the digitized raw signal sample points of the unknown signal when the template is the ensemble average of the raw signal sample points acquired during a known rhythm and aligned using the fourth order difference signal, as described in the template generation described in commonly assigned U.S. patent application Ser. No. 13/826,097, incorporated herein by reference in its entirety. In another variation, the template may be the fourth order difference signal of ensemble averaged raw signals, and the fourth order difference signal of the unknown raw signal is aligned with the fourth order difference template.

[0128] FIG. 12 is a flowchart of a method for computing a morphology metric to determine the similarity between a known template aligned with an unknown cardiac cycle signal according to one embodiment. After aligning the unknown beat and the template using the fourth order difference signal alignment points, the morphology between the unknown beat and the template is compared, Block 820. Numerous types of morphology analysis could be used, such as wavelet analysis, comparisons of fiducial points (peak amplitude, zero crossings, maximum slopes, etc.) or other techniques. In one embodiment, a NWAD is computed using a morphology analysis window that is a subset of, i.e. a number of sample points less than, the alignment window.

[0129] The operations performed by the device as described in conjunction with FIG. 12 may be performed on the aligned raw signal and corresponding template and/or the aligned fourth order difference signal and corresponding fourth order difference signal template.

[0130] As illustrated in FIG. 12, during the comparing of an individual beat with the beat template, the device determines the R-wave width of the unknown signal, Block 822. In an illustrative embodiment, in order to determine the R-wave width, the device determines an onset and an offset point of the R-wave. During the determination of the onset and offset, the maximum positive pulse and the maximum negative of the fourth order difference signal are identified. The maximum positive pulse is an identified pulse having positive polarity and maximum positive peak value; the maximum negative pulse is an identified pulse having negative polarity and maximum absolute peak value. If the R wave has a positive polarity in the raw ECG signal, the maximum positive pulse will precede the maximum negative pulse on the 4th-order difference waveform. An onset threshold is set based on the amplitude of the maximum positive pulse and an offset threshold is set based on the amplitude of the maximum negative pulse. For example,

one-eighth of the peak amplitude of the maximum positive pulse may be defined as the onset threshold and one eighth of the negative peak amplitude of the maximum negative pulse may be defined as the offset threshold.

[0131] The onset of the R-wave is identified as the first sample point to the left of the maximum positive pulse (e.g. moving from the pulse peak backward in time to preceding sample points) to cross the onset threshold. The offset of the R-wave is identified as the first sample point to the right of the maximum negative pulse crossing the offset threshold. The R-wave width is the difference between the onset sample point number and the offset sample point number, i.e. the number of sampling intervals between onset and offset.

[0132] For an R-wave having a negative polarity on the raw waveform, the maximum negative pulse will precede the maximum positive pulse on the fourth order difference signal. As such, the onset threshold is set as a proportion of the maximum negative peak amplitude of the maximum negative pulse of the fourth order difference signal, and the offset threshold is set as a proportion of the maximum positive peak amplitude of the maximum positive pulse. The R-wave onset is detected as the first sample point to cross the onset threshold when moving left (earlier in time) from the maximum negative peak. The R-wave offset is detected as the first sample point to cross the offset threshold moving right (later in time) from the maximum positive peak. The R-wave width is the difference between the onset sample point and the offset sample point. This method of computing an R-wave width based on onset and offset points identified from the fourth order difference signal is illustrated below in FIG. 14.

[0133] The device sets a morphology analysis window in response to the R-wave width determined from the fourth order difference signal, Block 824. The morphology of the R-wave itself is of greatest interest in classifying the unknown beat. Processing time can be reduced by comparing only the sample points of greatest interest without comparing extra points, for example baseline points or Q- or S-wave points, preceding or following the R-wave. The morphology analysis window is therefore a proportion of the sample points that is less than the total number of sample points aligned in the alignment window.

[0134] In one embodiment, different ranges of R-wave width measurements may be defined for which different respective sample numbers will be used to set the morphology analysis window. For example, if the R-wave width is greater than 30 sample intervals, the morphology analysis window is set to a first number of sample points. If the R-wave width is greater than 20 sample intervals but less than or equal to 30 sample intervals, the morphology analysis window is set to a second number of sample points less than the first number of sample points. If the R-wave width is less than or equal to 20 sample points, the morphology analysis window is set to a third number of sample points less than the second number of sample points. Two or more R-wave width ranges may be defined, each with a corresponding number of sample points defining the morphology analysis window. At least one of the R-wave width ranges is assigned a number of sample points defining the morphology analysis window to be less than the alignment window. In some embodiments all of the R-wave width ranges are assigned a number of sample points defining the morphology analysis window to be less than the alignment window.

[0135] In the example given above, the alignment window is 53 sample points. If the R-wave width is greater than 30 sample intervals, the morphology window is defined to be 48 sample points. The morphology analysis window may include 23 points preceding the R-wave sense point, the R-wave sense point itself, and 24 points after the R-wave sense point. If the R-wave width is greater than 20 but less than or equal to 30 sample intervals, the morphology window is defined to be 40 sample points (e.g. 19 before the R-wave sense point and 20 after the R-wave sense signal). If the R-wave width is less than or equal to 20 sample intervals, the window is defined to be 30 sample points (e.g. 14 before and 15 points after the R-wave sense point and including the R-wave sense point).

[0136] In other embodiments, the number of sample points in the morphology analysis window may be defined as a fixed number of sample points greater than the R-wave width, for example the R-wave width plus 12 sample points. In another example, the number of sample points defining the morphology analysis window may be computed as the R-wave width plus a rounded or truncated percentage of the R-wave width. For example, the morphology analysis window may be defined as the R-wave width plus fifty percent of the R-wave width (i.e. 150% of the R-wave width), up to a maximum of the total alignment window or some portion less than the total alignment window.

[0137] The morphology window is applied to both the unknown beat and the template. With the template and unknown cardiac signal aligned within the alignment window, the same number of sample points taken prior to and after the unknown beat alignment point is taken prior to and after the template alignment point.

[0138] After setting the morphology analysis window, Block 824, a morphology metric of the similarity between the unknown signal and the template, such as the normalized waveform area difference (NWAD), for example, is computed, Block 826. Different methods may be used to compute a NWAD. In an illustrative method, the NWAD is computed by normalizing the absolute amplitude of each of the unknown beat sample points and the template sample points within the morphology window by a respective absolute maximum peak amplitude value. A waveform area difference is then calculated by summing the absolute amplitude differences between each aligned pair of normalized sample points in the unknown signal and in the template over the morphology window.

[0139] This waveform area difference may be normalized by a template area. The template area is computed as the sum of all of the absolute values of the normalized template sample points in the morphology window. The NWAD is then calculated as the ratio of the waveform area difference to the template area. The NWAD for the aligned signals is stored.

[0140] This NWAD may be compared to a threshold to classify the unknown beat as matching the template based on a high correlation between the unknown beat and the template evidenced by a NWAD exceeding a match threshold. One or more NWADs may be computed for a given unknown beat. In the example shown in FIG. 12, additional NWADs may be computed by shifting the aligned template relative to the already aligned unknown signal by one or more sample points, Block 828. In one embodiment, the template is shifted by one sample point to the right, two sample points to the right, one sample point to the left and

two sample points to the left to obtain five different alignments of the template and unknown signal. For each template alignment, i.e. with alignment points aligned, and with template and unknown signal alignment points shifted relative to each other by one point and two points in each direction, a NWAD is computed, Block 830. In this way, five NWADs are computed to measure the similarity between the unknown beat and the template (in aligned and shifted positions).

[0141] The device selects the NWAD having the greatest value as the morphology metric for the unknown beat, which is then compared to the match threshold, Block 832, to classify the unknown beat as being either a match beat or a non-match, Block 834, as described above in Blocks 724-728 of FIG. 10.

[0142] FIG. 13 is an exemplary plot of alignment of an unknown beat and a template for computing a normalized waveform area difference during beat-based analysis, according to one embodiment. As illustrated in FIG. 13, the unknown raw ECG signal 902 and the raw ECG signal template 904 (ensemble average of *n* raw signals aligned using fourth order difference signal) are used for determining a morphology match metric over a morphology analysis window 912. The width of the morphology analysis window 912 and the alignment of the unknown signal 902 and template 904 are based on analysis of fourth order difference.

[0143] The raw ECG signal 902 is aligned with a template alignment point 906 of the template 904 of the raw ECG signal established during NSR, identified from an ensemble averaged fourth order difference signal as the maximum absolute pulse amplitude value. An unknown signal alignment point 908 is identified from the fourth order difference signal of the unknown raw ECG signal 902. The unknown signal alignment point 908 is the maximum absolute pulse amplitude value having the same polarity as the template alignment point 906.

[0144] After aligning the template 904 with the unknown raw ECG signal 902 over an alignment window 910, a morphology window 912 is set. The morphology window 912 is a subset of, i.e. shorter than or fewer sample points than, the alignment window 910. The morphology window 912 is set based on an R-wave width measured from the fourth order difference signal of the unknown signal as described below in conjunction with FIG. 14. The morphology analysis window 912 is set in response to the R-wave width measurement as some sample number greater than the R-wave width, as described above.

[0145] The device determines a template area 914 as the sum of all of the normalized absolute values of the template sample points within the morphology analysis window 912. The values are normalized by the absolute value of the maximum amplitude of the template. The waveform area difference 916 is computed as the summation of the absolute values of the differences between the aligned normalized absolute values of the unknown ECG signal sample points and the normalized absolute values of the template sample points. The NWAD is determined by taking the ratio of the waveform area difference 916 to the template area 914, which is then used in the determination, Block 724, of whether the unknown beat is a match beat, Block 726, or a non-match beat, Block 728, in FIG. 10.

[0146] FIG. 14 is an exemplary plot illustrating a technique for determining an R-wave width and computing a

normalized waveform area difference during beat-based analysis, according to another embodiment. In the example illustrated in FIG. 14, a fourth order difference signal 920 of the unknown raw ECG signal is aligned with a fourth order difference signal template 922 for determining a morphology match metric over a morphology analysis window 930.

[0147] The unknown fourth order difference signal 920 is derived from the unknown raw ECG signal sensed by the device and is aligned with the fourth order difference template 922 established during NSR. The template alignment point 924 is identified as the maximum absolute pulse amplitude value of the fourth order difference template. The unknown signal alignment point 926 is identified as the maximum absolute pulse amplitude value having the same polarity as the template alignment point 924. The unknown fourth order difference signal 920 is shifted over the alignment window 928 by an alignment shift required to align the unknown signal alignment point 926 with the template alignment point 924 as shown.

[0148] After aligning the template 922 with the unknown fourth order difference signal 920 over alignment window 928, a morphology window 930 is set. The morphology window 930 is a subset of the alignment window 928 and is based on an R-wave width 932 measured from the unknown fourth order difference signal 920.

[0149] In order to determine the R-wave width 932, the device determines the difference between an R-wave onset point 934 and an R-wave offset point 936 of the fourth order difference signal 920 of the unknown beat. In order to determine an R-wave onset point 934, the device determines a maximum positive pulse peak amplitude 938, and sets an onset threshold 940 as a proportion of the maximum positive pulse peak amplitude 938. In one embodiment, the device sets the onset threshold 940 as one-eighth of the maximum positive pulse peak amplitude 938. The onset point 934 is identified as the first point to the left of the maximum positive pulse peak crossing the onset threshold 940, i.e. equal to or greater than the onset threshold 940.

[0150] The device sets an offset threshold 942 as a proportion of a maximum negative pulse peak amplitude 944, and the offset point 936 is identified as the first point crossing the offset threshold 942 to the right of the maximum negative pulse. The device determines the R-wave width 932 as being the difference between the onset point 934 and the offset point 936. The morphology analysis window 930 is set in response to the R-wave width measurement as some sample number greater than the R-wave width 932, as described previously.

[0151] In other examples, the maximum negative pulse may occur earlier in the alignment window than the maximum positive pulse. If this is the case, the onset threshold is set as a proportion of the maximum negative pulse peak amplitude and the onset point is determined as the first point crossing the onset threshold to the left of the maximum negative peak. Likewise, the offset threshold is set as a proportion of the maximum positive pulse peak amplitude, and the offset point is determined as the first point to the right of the maximum positive pulse to cross the offset threshold.

[0152] The morphology analysis window 930 may be centered on an R-wave sense signal. In some embodiments, the morphology analysis window 930, determined from the fourth order difference signal 920, is applied to the unknown raw ECG signal aligned with a raw ECG signal template, for

example analysis window 912 as shown in FIG. 13. The morphology match metric is determined from the raw ECG signal 902 and template 904. In the example illustrated in FIG. 14, the morphology analysis window 930 is applied to the fourth order difference signal 920; the morphology match metric is determined from the fourth order difference signal 920 and fourth order difference template 922.

[0153] The template area 946 is computed as the sum of all of the normalized absolute values of the template sample points within the morphology window 930. The values are normalized by the absolute value of the maximum amplitude of the template 922 (in this example point 926). The device determines the waveform area difference 948 as the summation of the absolute differences between the aligned normalized absolute values of the unknown fourth order difference signal sample points and the normalized absolute values of the template sample points. The NWAD is determined by the device as the ratio of the waveform area difference 948 and the template area 946, and is compared to a match threshold to classify the unknown beat corresponding to the fourth order difference signal 920 as being either a match beat or a non-match beat, Blocks 726 and 728 of FIG. 10.

[0154] Returning to FIG. 10, during the periodic normal beats analysis, Block 368 of FIG. 4, once the individual beat is identified as being either a match beat, Block 726, or a non-match beat, Block 728, using the normalized waveform area difference analysis described above, for example, the device determines whether an R-wave width associated with the beat satisfies an R-wave width threshold, Block 730. For example, the R-wave width associated with the beat determined during the beat analysis of Block 722, described above in reference to FIG. 14, is compared to an R-wave template, and a determination of the difference between the R-wave associated with the beat and the template is made. If the difference is less than or equal to a predetermined width difference threshold, such as 22 milliseconds, for example, the beat is determined to satisfy the R-wave width threshold, Yes in Block 730. On the other hand, if the difference between the R-wave associated with the beat and the template is greater than the predetermined width difference threshold, the beat is determined to not satisfy the R-wave width threshold, No in Block 730. If the beat is both a match beat, Block 726 and satisfies the R-wave width threshold, Yes in Block 730, the beat is identified as a normal beat, Block 732. If the beat is either a non-match beat, Block 728, or is a match beat, Block 726, but does not satisfy the R-wave width threshold, No in Block 730, the beat is identified as being a not normal beat, Block 734.

[0155] Once the beat is identified as either being either a normal beat, Block 732, or a not normal beat, Block 734, the device determines whether the determination has been made for all of the beats in the three-second window, Block 736. If the determination has not been made for all of the beats in the three-second window, the process of identifying a beat as being either a match beat or a non-match beat and a normal beat or a not normal beat, Blocks 720-734, is repeated for the next beat.

[0156] Once all of the beats within the three-second window have been identified as being either a normal beat, Block 732, or a not normal beat, Block 734, Yes in Block 736, the device determines whether periodic normal beats are detected for the three-second window, Block 738, as described below. If periodic normal beats are not detected,

No in Block **738**, the three-second window is identified as being shockable, Block **740**. If periodic normal beats are detected, Yes in Block **738**, the three-second window is identified as being not shockable, Block **742**.

[0157] The resulting determination of the three-second window as being identified as one of shockable or not shockable based on the periodic normal beats detection is then used, in combination with the determination of the sensing channel or channels being either shockable or not shockable, Blocks **353**, **355**, **357** and **363-369** of FIG. **4** during the morphology analysis of the whole waveform, described above, to determine state transitions of the device. For example, if the three-second segment for the channel is identified as being shockable during the gross morphology analysis, and classified as not shockable during the periodic normal beats analysis, i.e., periodic normal beats were detected, then the three-second segment is classified as not being shockable. On the other hand, if the three-second segment for the channel is identified as being shockable during the gross morphology analysis, and classified as being shockable during the periodic normal beats analysis, i.e., periodic normal beats were not detected, then the three-second segment is classified as being shockable.

[0158] FIG. **15** is a flowchart of an exemplary method for determining whether periodic normal beats are detected within a predetermined sensing vector during the periodic normal beats analysis of FIG. **10**. As illustrated in FIG. **15**, according to one embodiment, in order to determine whether periodic normal beats are detected for the three-second window in Block **738** of FIG. **10**, the device may determine whether the number of normal beats identified within the three-second window is greater than or equal to a predetermined threshold, Block **750**. For example, according to one embodiment, the device determines whether four or more normal beats were identified in the three-second window. If the number of normal beats identified in the three-second window is not greater than or equal to the predetermined threshold, No Block **750**, periodic normal beats are not detected for the window, and the result of the periodic normal beats detection is to identify the three-second window as being shockable, Block **740**.

[0159] In addition to determining whether the number of normal beats identified in the three-second window is greater than or equal to the predetermined threshold, Yes in Block **750**, the device may determine whether an RR interval associated with the four or more periodic beats is less than an RR interval threshold, Block **752**, such as **300** milliseconds for example. If the RR interval associated with the four or more periodic beats is less than the RR interval threshold, Yes in Block **752**, the device determines whether the determination has been performed for all of the identified normal beats, Block **751**. If the determination has been made for all of the RR intervals associated with the four or more beats, Yes in Block **751**, and therefore the RR intervals have been determined to be less than the RR interval, the result of the periodic normal beats detection is to identify the three-second window as being shockable, Block **740**. If the determination has not been made for all of the RR intervals, No in Block **751**, the next one of the RR intervals is compared to the RR interval threshold in Block **752**, and the process is repeated for the next interval.

[0160] If the RR interval associated with the four or more periodic beats is greater than or equal to the RR interval threshold, No in Block **752**, the device may also determine

whether the RR intervals are within a relative interval range relative to that interval, Block **754**. If the RR intervals are not within the relative interval range, No in Block **754**, the device determines whether the determination for Block **752** has been performed for all of the intervals associated with the identified normal beats, Block **751**. If the determination as to whether the RR interval is less than the RR interval threshold has been made for all of the RR intervals associated with the four or more beats, Yes in Block **751**, the result of the periodic normal beats detection is to identify the three-second window as being shockable, Block **740**. If the determination has not been made for all of the RR intervals, No in Block **751**, the next one of the RR intervals is compared to the RR interval threshold in Block **752**, and the process is repeated for the next interval. If the RR intervals are within the relative interval range, Yes in Block **754**, the result of the periodic normal beats detection is to identify the three-second window as being not shockable, Block **742**.

[0161] It is understood that the device may perform the periodic normal beats detection using any of the periodic normal beats parameters, Blocks **750-754**, alone or in combination, and in any order to identify the three-second window as being not shockable, Block **742**, or shockable, Block **740**.

[0162] FIG. **16** is a schematic diagram of an exemplary cardiac signal sensed within a sensing detection window during detection of a cardiac event. As illustrated in FIG. **16**, the device senses a cardiac signal **800** via sensing channel ECG1 or ECG2 during a sensing window **802**. In the example illustrated, while the cardiac signal **800** includes multiple sensed beats **804**, the device determines, as a result of the periodic normal beats analysis, Block **368** of FIG. **4**, described above, that four beats **806-812** of the multiple sensed beats **804** are classified as being normal beats, with the four normal beats **806-812** resulting in three RR intervals **814-818**.

[0163] Assuming one of the three RR intervals **814-818** is determined to be greater than or equal to the interval threshold, No in Block **752** of FIG. **15**, in order to determine whether the RR intervals are within a relative interval range, Block **754**, the device compares the interval to each of the other intervals and determines whether the RR intervals are within a predetermined interval range, such as one sixteenth. For example, assuming the device has determined that interval **814** is not less than the RR interval threshold, No in Block **752**, interval **814** is compared to interval **816** and to interval **818**. If the intervals **814-818** are determined to be within the interval range, i.e., intervals **816** and **818** are within one sixteenth of interval **814**, the RR intervals **814-816** are determined to be within a relative interval range, Yes in Block **754** of FIG. **15**, and the result of the periodic normal beats detection is to identify the three-second window as being not shockable, Block **742**. If the intervals **814-818** are not determined to be within the interval range, i.e., one or both of intervals **816** and **818** are not within one sixteenth of interval **814**, the RR intervals **814-816** are determined not to be within the relative interval range, No in Block **754** of FIG. **15**, and the result of the periodic normal beats detection is to identify the three-second window as being shockable, Block **740**.

[0164] If the device had determined, for example, that interval **814** was greater than the interval threshold, Yes in Block **752**, and that not all of the intervals had been compared to the RR interval threshold, No in Block **753**, the

device would then compare one of the other intervals to the RR interval threshold, Block 752, and the process is repeated using that interval. For example, if interval 816 is determined to be not less than the RR interval threshold, No in Block 752, interval 816 is compared to interval 814 and to interval 818, and if the intervals 814-818 are determined to be within the interval range, i.e., intervals 814 and 818 are within one sixteenth of interval 816, the RR intervals 814-816 are determined to be within a relative interval range, Yes in Block 754 of FIG. 15, and the result of the periodic normal beats detection is to identify the three-second window as being not shockable, Block 742. If the intervals 814-818 are not determined to be within the interval range, i.e., one or both of intervals 814 and 818 are not within one sixteenth of interval 816, the RR intervals 814-816 are determined not to be within the relative interval range, No in Block 754 of FIG. 15, and the result of the periodic normal beats detection is to identify the three-second window as being shockable, Block 740.

[0165] In the same way, the process of one or both of Blocks 752 and 754 may be performed using interval 816 and comparing intervals 814 and 816 to interval 818 to determine whether the intervals are within the interval range for Block 754, as described above.

[0166] In this way, during the determination in Block 370 of FIG. 4 as to whether to advance from the concerned state 304 to the armed state 306, if the predetermined number of three-second segments in both channels ECG1 and ECG2 have not been classified as shockable during the gross morphology analysis, i.e., both channels are not shockable (Blocks 351, 355, 357, 359, 365 and 367), the device does not transition to the next state, No in Block 370, and a determination as to whether to transition back to the not concerned state 302 is made, Block 372, as described above. If both channels are determined to be shockable during the gross morphology analysis (Blocks 353, 357, 363 and 369), but one channel is determined to include periodic normal beats during the periodic normal beat analysis described above, and therefore that channel is identified as being not shockable during the periodic normal beats analysis, the gross morphology determination of the channel being shockable is overridden, resulting in both channels no longer being shockable. As a result, the device does not transition to the next state, No in Block 370, and a determination as to whether to transition back to the not concerned state 302 is made, Block 372, as described above. On the other hand, if both channels are determined to be shockable during the gross morphology analysis (Blocks 353, 357, 363 and 369), and none of the channels is determined to include periodic normal beats during the periodic normal beat analysis described above, the device transitions to the next state, Yes in Block 370, as described above.

[0167] FIG. 17 is a flowchart of an exemplary method for determining whether periodic normal beats are detected within a predetermined sensing vector during the periodic normal beats analysis of FIG. 10. According to one exemplary embodiment, during the periodic normal beats analysis, Block 368, the determination of whether periodic normal beats occur may be made using two consecutive three-second sensing windows for the channels ECG1 and ECG2. In particular, the determination of whether beats are normal beats Block 732 of FIG. 10 or not normal beats, Block 734, is made for all of the beats in two consecutive sensing windows. As illustrated in FIG. 17, according to an exem-

plary example, when two consecutive sensing are utilized, the device may determine whether the number of normal beats identified within the two three-second windows is greater than or equal to a predetermined threshold, Block 760. For example, according to one embodiment, the device determines whether four or more normal beats were identified in the two three-second windows. If the number of normal beats identified in the two three-second window is not greater than or equal to the predetermined threshold, No Block 760, periodic normal beats are not detected for the two three-second windows, and the result of the periodic normal beats detection is to identify the three-second windows as being shockable, Block 740.

[0168] If the number of normal beats identified in the two three-second window is greater than or equal to the predetermined threshold, Yes in Block 760, the device may also determine whether the distribution of the normal beats is greater than or equal to a normal beats distribution threshold, Block 762. For example, according to one embodiment, the device determines whether one or more of the normal beats occurred in the most recent three-second window of the two consecutive three-second windows. If the distribution of the normal beats is not greater than or equal to the normal beats distribution threshold, No in Block 762, periodic normal beats are not detected for the two three-second windows, and the result of the periodic normal beats detection is to identify the three-second windows as being shockable, Block 740.

[0169] If the distribution of the normal beats is greater than or equal to the normal beats distribution threshold, Yes in Block 762, the device may determine whether the total number of normal beats occurring in the two three-second windows is less than or equal to a threshold total number of normal beats, Block 764. The threshold number of total normal beats may be a predetermined number, for example, or may be a proportion of the total number of beats, both normal and not normal beats, detected during the two three-second windows, such as $\frac{3}{8}$, for example. If the total number of normal beats occurring in the two three-second windows is greater than, i.e., not less than or equal to, the threshold number of total normal beats, No in Block 764, periodic normal beats are not detected for the two three-second windows, and the result of the periodic normal beats detection is to identify the three-second windows as being shockable, Block 740.

[0170] If the total number of normal beats occurring in the two three-second windows is less than or equal to the threshold number of total normal beats, Yes in Block 764, the device may determine whether an RR interval associated with the four or more periodic beats is less than an RR interval threshold, Block 766, such as 300 milliseconds for example. If the RR interval associated with the four or more periodic beats is less than the RR interval threshold, Yes in Block 766, the device determines whether the determination has been performed for all of the identified normal beats, Block 765. If the determination has been made for all of the RR intervals associated with the four or more beats, Yes in Block 765, and therefore all of the RR intervals have been determined to be less than the RR interval, the result of the periodic normal beats detection is to identify the three-second window as being shockable, Block 740. If the determination has not been made for all of the RR intervals, No in Block 765, the next one of the RR intervals is compared to the RR interval threshold in Block 752, and the process is repeated for the next interval, as described above.

[0171] If an RR interval associated with the four or more periodic beats are greater than or equal to the RR interval threshold, No in Block 766, the device may also determine whether the RR intervals are within a relative interval range of that interval, Block 768, such as one-sixteenth as described above. If the RR intervals are not within the relative interval range, No in Block 768, the device determines whether the determination has been performed for all of the identified normal beats, Block 765. If the determination has been made for all of the RR intervals associated with the four or more beats, Yes in Block 765, and therefore all of the RR intervals have been determined to be less than the RR interval, the result of the periodic normal beats detection is to identify the three-second window as being shockable, Block 740. If the determination has not been made for all of the RR intervals associated with the four or more beats, No in Block 765, the process is repeated using a next beat, as described above. If the RR intervals are within the relative interval range, Yes in Block 768, the result of the periodic normal beats detection is to identify the three-second window as being not shockable, Block 742.

[0172] It is understood that the device may perform the periodic normal beats detection using any of the periodic normal beats parameters, Blocks 760-768, alone or in combination, and in any order to identify the three-second window as being not shockable, Block 742, or shockable, Block 740.

[0173] According to another embodiment, the device may also determine whether the RR intervals are within a relative interval range, Block 768, by determining whether, for any of the RR intervals, nRR_i , two or more of the remaining RR intervals are determined to be one half of the RR interval, nRR_i , or twice the RR interval, nRR_i . In addition, the device may determine the sum of the number of the normal RR intervals other than a current identified RR interval, nRR_i , that fall within one sixteenth of the current RR interval, nRR_i , and the number of the normal RR intervals other than the current identified RR interval, nRR_i , that are one half of the length of the current RR interval, nRR_i , plus the number of the normal RR intervals other than the current identified RR interval, nRR_i , that are twice the length of the current RR interval, nRR_i . If the total number of these RR intervals is greater than or equal to two, for example, then periodic normal beats are determined to occur, and the two three second windows are determined to be not shockable for the periodic normal beats determination.

[0174] As a result, the decision on state transitions (e.g. as to whether to transition from the concerned operating state 304 to the armed operating state 306 in Block 370, or from the armed state 306 to the shock state 308) is made based on the results of both an analysis of the gross morphology of the signal in the three-second window or windows for each sensing channel ECG1 and ECG2, and a determination of whether periodic normal beats occur within one or more of the three-second windows for one or both sensing channel ECG1 and ECG2, as described below. For a three-second segment to be classified as shockable, both the gross morphology and periodic normal beats analysis have to classify the same three-second segment or segments as being shockable.

[0175] For example, according to an embodiment of the present invention, in order to determine whether to transition from the concerned operating state 304 to the armed operating state 306, the device determines whether a predeter-

mined number, such as two out of three for example, of three-second segments for both channels ECG1 and ECG2 have been classified as being shockable during the gross morphology analysis, Blocks 353, 357, 363 and 369, and determines whether periodic normal beats have been determined to occur for one or more of the three-second segments for the channels, Block 368. If the predetermined number of three-second segments in both channels ECG1 and ECG2 have been classified as shockable during both the gross morphology analysis and the periodic normal beats detection, the device transitions from the concerned state 304 to the armed state 306, Yes in Block 370. When the device determines to transition from the concerned state 304 to the armed state 306, Yes in Block 370, processing continues to be triggered by a three-second time out as is utilized during the concerned state 304, described above.

[0176] If the predetermined number of three-second segments in both channels ECG1 and ECG2 have not been classified as shockable during both the gross morphology analysis and the periodic normal beats detection, the device does not transition from the concerned state 304 to the armed state 306, No in Block 370, and a determination as to whether to transition back to the not concerned state 302 is made, Block 372. The determination as to whether to transition from the concerned state 304 back to the not concerned state 302 is made, for example, by determining whether a heart rate estimate is less than a heart rate threshold level in both of the two channels ECG1 and ECG2, using the method for determining a heart rate estimate as described in U.S. Pat. No. 7,894,894 to Stadler et al., incorporated herein by reference in its entirety. If it is determined that the device should not transition to the not concerned state 302, i.e., either of the two heart rate estimates are greater than the heart rate threshold, No in Block 372, the process continues using the signal generated during a next three-second window, Block 341.

[0177] Thus, a method and apparatus for detecting a cardiac event have been presented in the foregoing description with reference to specific embodiments. It is appreciated that various modifications to the referenced embodiments may be made without departing from the scope of the disclosure as set forth in the following claims.

We claim:

1. A method of detecting a cardiac event in a medical device, comprising:

- sensing cardiac signals from a plurality of electrodes;
- sensing a plurality of beats in response to the sensed cardiac signals;
- identifying each beat of the plurality of beats as one of a normal beat and a not normal beat;
- determining at least one of whether a number of beats identified as a normal beat is greater than a normal beat threshold, whether an RR interval associated with the beats identified as being a normal beat is less than a threshold interval, and whether RR intervals associated with the beats identified as being normal beats are within an RR interval range; and
- identifying the cardiac event as being one of shockable and not shockable in response to the determining.

2. The method of claim 1, wherein the plurality of electrodes form a first sensing vector and a second sensing vector, the method further comprising:

- performing a gross morphology analysis of a signal sensed along the first sensing vector during a predeter-

- mined sensing window and a signal sensed along the second sensing vector during the predetermined sensing window; and
- identifying the cardiac event as being one of shockable and not shockable in response to the performed gross morphology analysis.
3. The method of claim 2, further comprising determining whether to deliver a therapy to treat the cardiac event in response to both the identifying the cardiac event as being one of shockable and not shockable in response to the determining and the identifying the cardiac event as being one of shockable and not shockable in response to the performed gross morphology analysis.
4. The method of claim 1, wherein determining whether RR intervals associated with the beats identified as being normal beats are within an RR interval range comprises:
- comparing a duration of a first RR interval of the RR intervals associated with the beats identified as being normal beats to durations of RR intervals of the RR intervals associated with the beats identified as being normal beats other than the first RR interval to generate interval differences;
 - determining whether the interval differences are less than a relative interval difference threshold; and
 - determining the RR intervals associated with the beats identified as being normal beats are within the RR interval range in response to all of the interval differences being less than the relative interval difference threshold.
5. The method of claim 4, wherein determining whether the interval differences are less than a relative interval difference threshold comprises determining whether the durations of RR intervals of the RR intervals associated with the beats identified as being normal beats other than the first RR interval are within one sixteenth of the duration of the first RR interval.
6. The method of claim 1, further comprising:
- determining a distribution of the beats identified as being normal beats;
 - comparing the determined distribution of the beats identified as being normal beats to a distribution threshold; and
 - further identifying the cardiac event as being one of shockable and not shockable in response to the comparing.
7. The method of claim 1, further comprising:
- sensing the cardiac signals over consecutive predetermined sensing windows, the consecutive predetermined sensing windows comprising a first sensing window and a second sensing window occurring subsequent to the first sensing window;
 - determining a distribution of the beats identified as normal beats occurring within the first sensing vector and the second sensing vector; and
 - further identifying the cardiac event as being one of shockable and not shockable in response to the determined distribution.
8. The method of claim 7, wherein determining a distribution of the beats identified as normal beats occurring within the first sensing vector and the second sensing vector comprises determining whether one or more of the beats identified as being normal beats occur within the second sensing window.
9. The method of claim 1, further comprising:
- comparing a number of beats identified as being normal beats to a number identified as being not normal to a predetermined threshold; and
 - further identifying the cardiac event as being one of shockable and not shockable in response to the comparing.
10. The method of claim 9, wherein the predetermined threshold comprises a proportion of the plurality of beats.
11. A medical device for detecting a cardiac event, comprising:
- a plurality of electrodes sensing cardiac signals having a plurality of beats; and
 - a processor configured to identify each beat of the plurality of beats as one of a normal beat and a not normal beat, determine at least one of whether a number of beats identified as a normal beat is greater than a normal beat threshold, whether an RR interval associated with the beats identified as being a normal beat is less than a threshold interval, and whether RR intervals associated with the beats identified as being normal beats are within an RR interval range, identifying the cardiac event as being one of shockable and not shockable in response to the determining.
12. The medical device of claim 11, wherein the plurality of electrodes form a first sensing vector and a second sensing vector, the processor further configured to perform a gross morphology analysis of a signal sensed along the first sensing vector during a predetermined sensing window and a signal sensed along the second sensing vector during the predetermined sensing window, and identify the cardiac event as being one of shockable and not shockable in response to the performed gross morphology analysis.
13. The medical device of claim 12, wherein the processor is further configured to determine whether to deliver a therapy to treat the cardiac event in response to both the identifying the cardiac event as being one of shockable and not shockable in response to the determining and the identifying the cardiac event as being one of shockable and not shockable in response to the performed gross morphology analysis.
14. The medical device of claim 11, wherein determining whether RR intervals associated with the beats identified as being normal beats are within an RR interval range comprises:
- comparing a duration of a first RR interval of the RR intervals associated with the beats identified as being normal beats to durations of RR intervals of the RR intervals associated with the beats identified as being normal beats other than the first RR interval to generate interval differences;
 - determining whether the interval differences are less than a relative interval difference threshold; and
 - determining the RR intervals associated with the beats identified as being normal beats are within the RR interval range in response to all of the interval differences being less than the relative interval difference threshold.
15. The medical device of claim 14, wherein determining whether the interval differences are less than a relative interval difference threshold comprises determining whether the durations of RR intervals of the RR intervals associated with the beats identified as being normal beats other than the first RR interval are within one sixteenth of the duration of the first RR interval.

16. The medical device of claim **11**, wherein the processor is further configured to determine a distribution of the beats identified as being normal beats, compare the determined distribution of the beats identified as being normal beats to a distribution threshold, and further identify the cardiac event as being one of shockable and not shockable in response to the comparing.

17. The medical device of claim **11**, wherein the processor is further configured to sense the cardiac signals over consecutive predetermined sensing windows, the consecutive predetermined sensing windows comprising a first sensing window and a second sensing window occurring subsequent to the first sensing window, determine a distribution of the beats identified as normal beats occurring within the first sensing vector and the second sensing vector, and further identify the cardiac event as being one of shockable and not shockable in response to the determined distribution.

18. The medical device of claim **17**, wherein determining a distribution of the beats identified as normal beats occurring within the first sensing vector and the second sensing vector comprises determining whether one or more of the beats identified as being normal beats occur within the second sensing window.

19. The medical device of claim **11**, wherein the processor is further configured to compare a number of beats identified as being normal beats to a number identified as being not normal to a predetermined threshold, and further identify the cardiac event as being one of shockable and not shockable in response to the comparing.

20. The medical device of claim **19**, wherein the predetermined threshold comprises a proportion of the plurality of beats.

* * * * *

专利名称(译)	用于验证具有双感测向量的医疗设备中的心动过速事件的辨别的方法和设备		
公开(公告)号	US20170203114A1	公开(公告)日	2017-07-20
申请号	US15/477475	申请日	2017-04-03
[标]申请(专利权)人(译)	美敦力公司		
申请(专利权)人(译)	美敦力公司, INC.		
当前申请(专利权)人(译)	美敦力公司, INC.		
[标]发明人	ZHANG XUSHENG		
发明人	ZHANG, XUSHENG		
IPC分类号	A61N1/39 A61B5/0456 A61N1/362 A61B5/0464 A61B5/0452 A61B5/00 A61B5/042 A61B5/04		
CPC分类号	A61N1/3987 A61B5/0422 A61B5/0456 A61B5/04011 A61N1/3956 A61B5/04525 A61B5/686 A61B5/7207 A61N1/3621 A61B5/0464 A61B5/04012 A61B5/046 A61B5/0468 A61B5/7221 A61B5/7264 A61B5/7282 A61N1/3627 A61N1/368 A61N1/37 G16H50/20		
优先权	62/019658 2014-07-01 US		
其他公开文献	US10065045		
外部链接	Espacenet USPTO		

摘要(译)

一种用于检测心脏事件的方法和医疗设备，包括感测来自多个电极的心脏信号，响应于感测的心脏信号感测多个搏动，将多个搏动中的每个搏动识别为正常搏动之一和不是正常节拍，确定被识别为正常节拍的节拍数是否大于正常节拍阈值，与被识别为正常节拍的节拍相关联的RR间隔是否小于阈值间隔中的至少一个，以及是否与被识别为正常搏动的搏动相关联的RR间隔在RR间期范围内，并且响应于该确定将心脏事件识别为可电击和不可电击之一。

