



US 20170135896A1

(19) **United States**

(12) **Patent Application Publication**
Snow

(10) **Pub. No.: US 2017/0135896 A1**

(43) **Pub. Date: May 18, 2017**

(54) **SENSORY STIMULATION OR MONITORING APPARATUS FOR THE BACK OF NECK**

A61B 5/11 (2006.01)

A61B 5/00 (2006.01)

A61N 1/36 (2006.01)

A61B 5/021 (2006.01)

(71) Applicant: **Copa Animal Health, LLC**, Wayzata, MN (US)

(52) **U.S. Cl.**

CPC *A61H 23/008* (2013.01); *A61N 1/36014*

(2013.01); *A61B 5/02438* (2013.01); *A61B*

5/026 (2013.01); *A61B 5/021* (2013.01); *A61B*

5/0476 (2013.01); *A61B 5/1118* (2013.01);

A61B 5/6822 (2013.01); *A63B 71/0622*

(2013.01); *A63B 71/0686* (2013.01); *A63B*

2071/0625 (2013.01); *A63B 2071/0655*

(2013.01); *A61H 2205/02* (2013.01); *A61H*

2205/04 (2013.01)

(72) Inventor: **Buddy L. Snow**, Wayzata, MN (US)

(21) Appl. No.: **15/269,655**

(22) Filed: **Sep. 19, 2016**

Related U.S. Application Data

(63) Continuation-in-part of application No. PCT/US2015/021286, filed on Mar. 18, 2015.

(60) Provisional application No. 61/955,384, filed on Mar. 19, 2014.

Publication Classification

(51) **Int. Cl.**

A61H 23/00 (2006.01)

A61B 5/024 (2006.01)

A61B 5/026 (2006.01)

A63B 71/06 (2006.01)

A61B 5/0476 (2006.01)

(57)

ABSTRACT

Described herein are wearable sensory stimulation and monitoring devices that can be worn around the back of the neck along and in contact with the spine. Apparatuses described herein stimulate one or more senses including auditory, tactile or olfactory. Apparatuses are also described that allow for sensing and monitoring of physiologic parameters such as heart rate, blood pressure and movement. The device also has features that allow for easy attachment or integration to articles worn on the head.

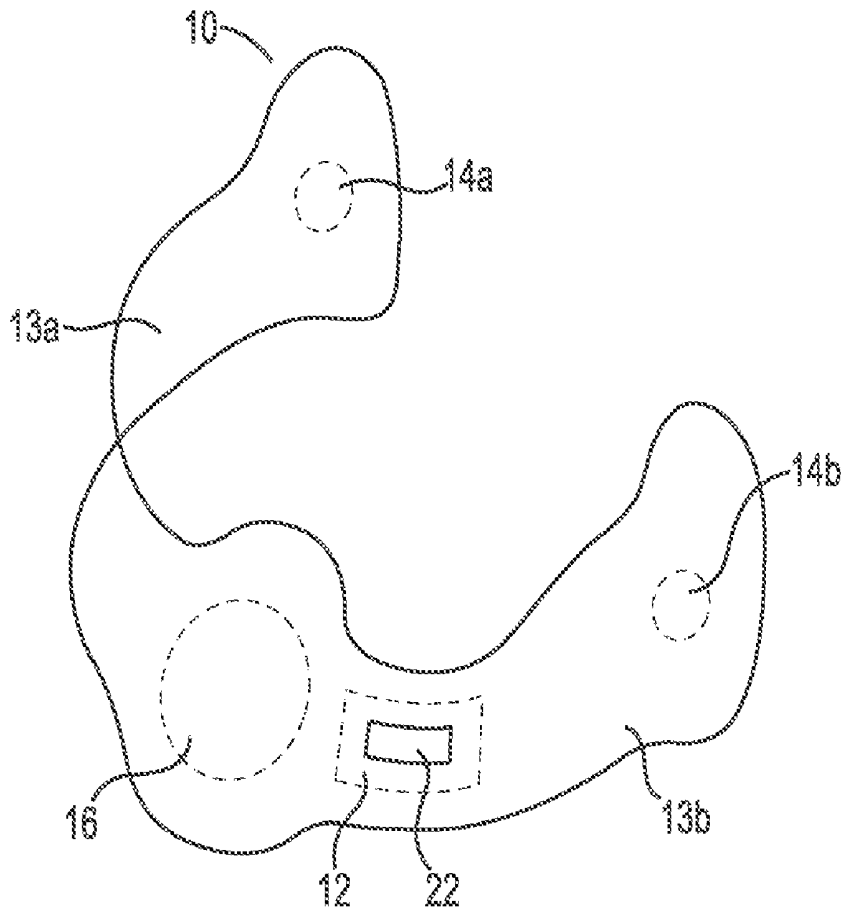

Figure 1A

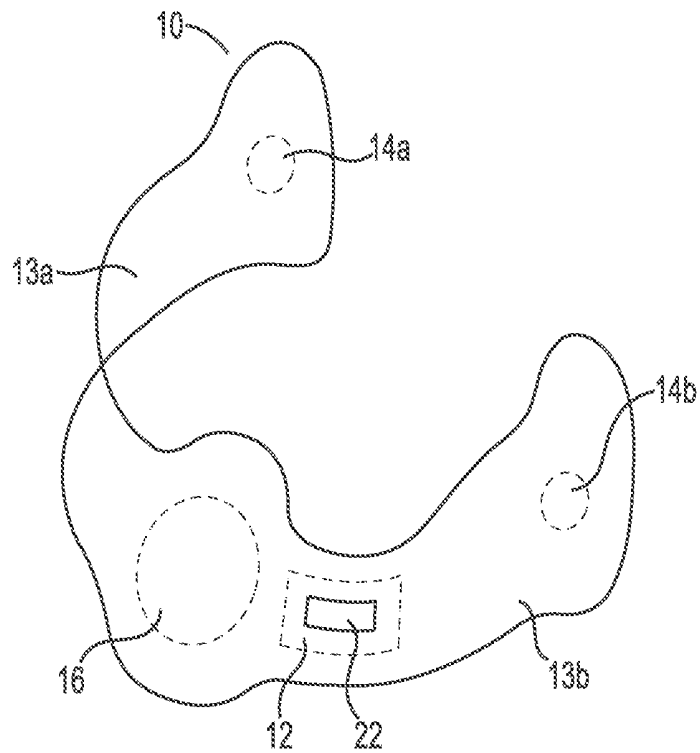

Figure 1B

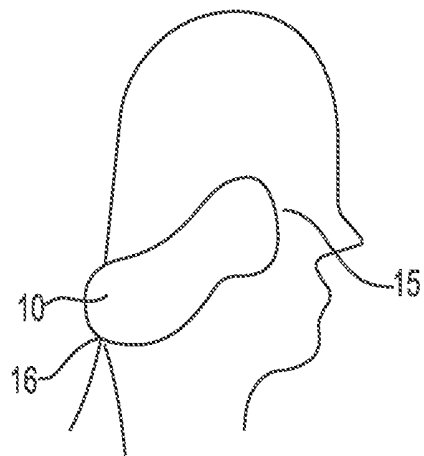

Figure 1C

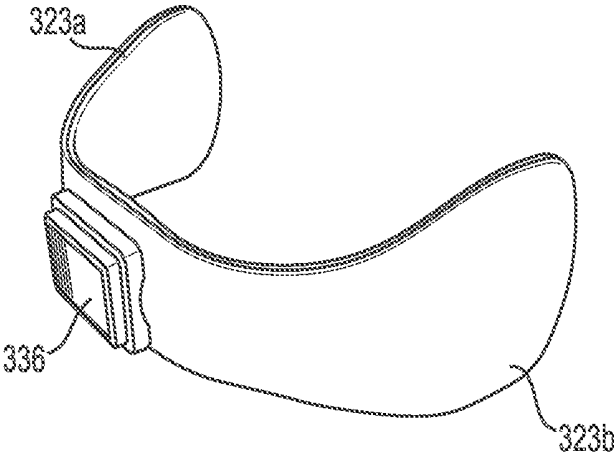

Figure 1D

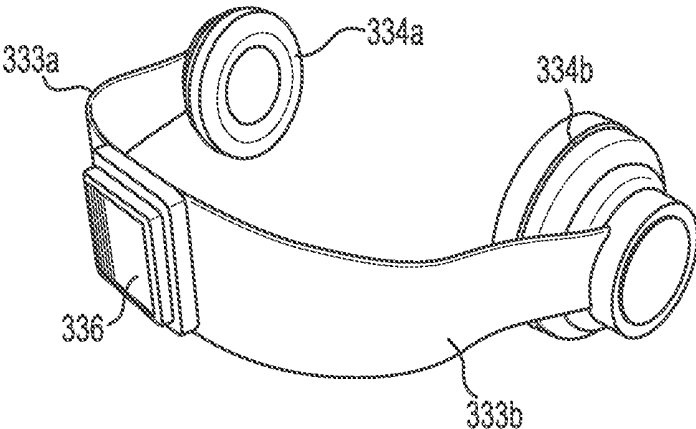

Figure 2A

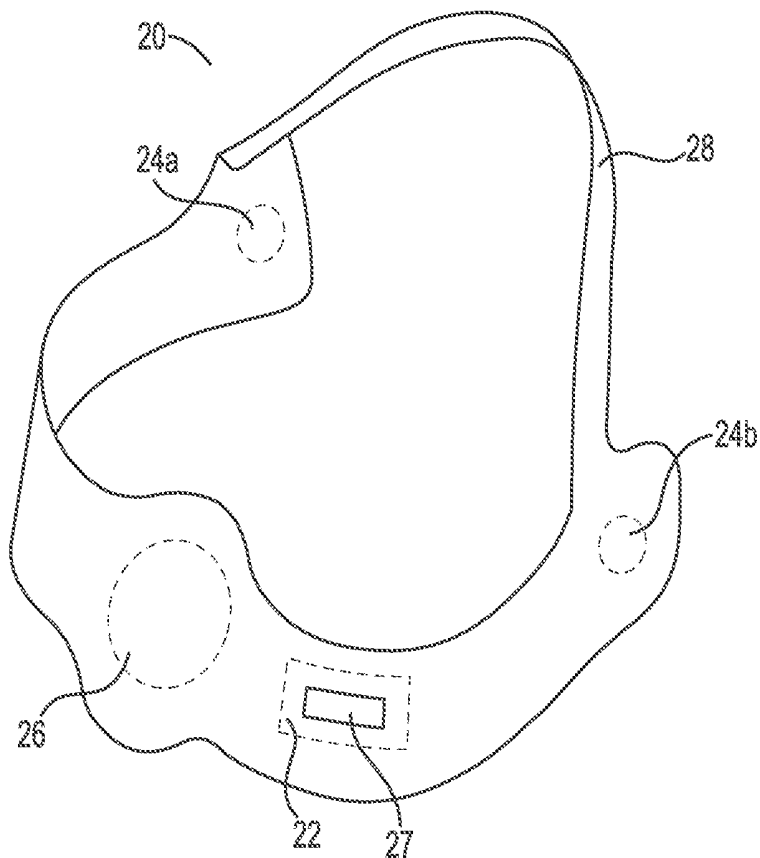

Figure 2B

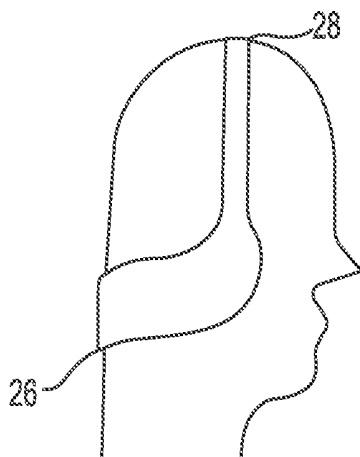

Figure 3

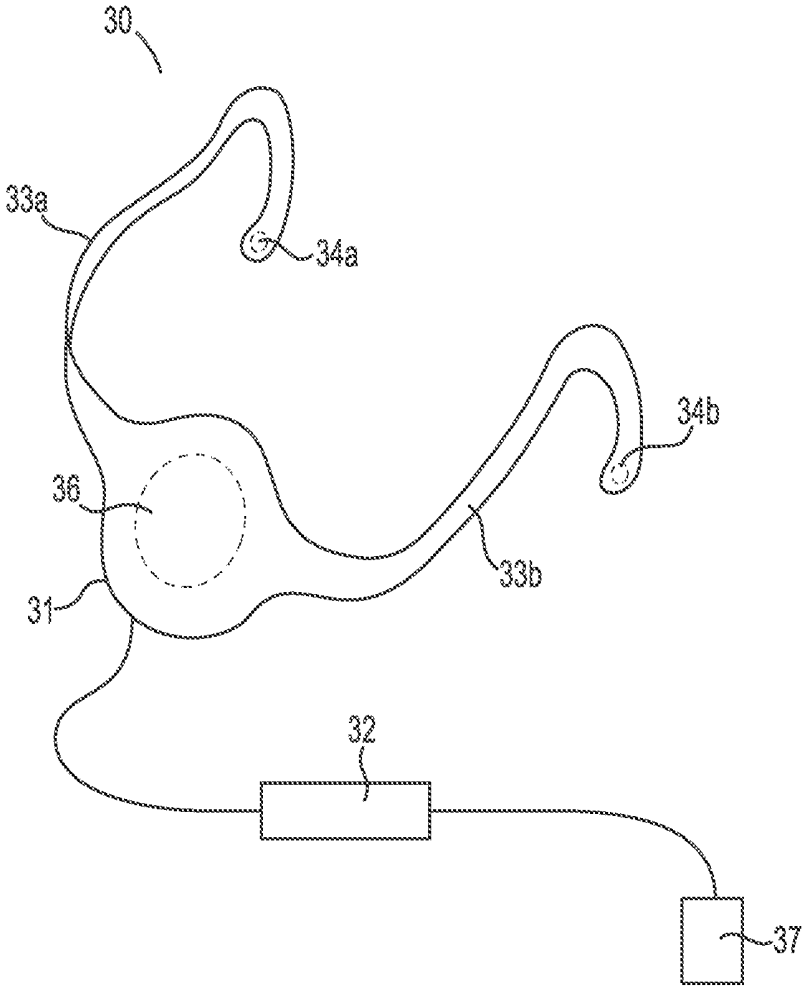

Figure 4

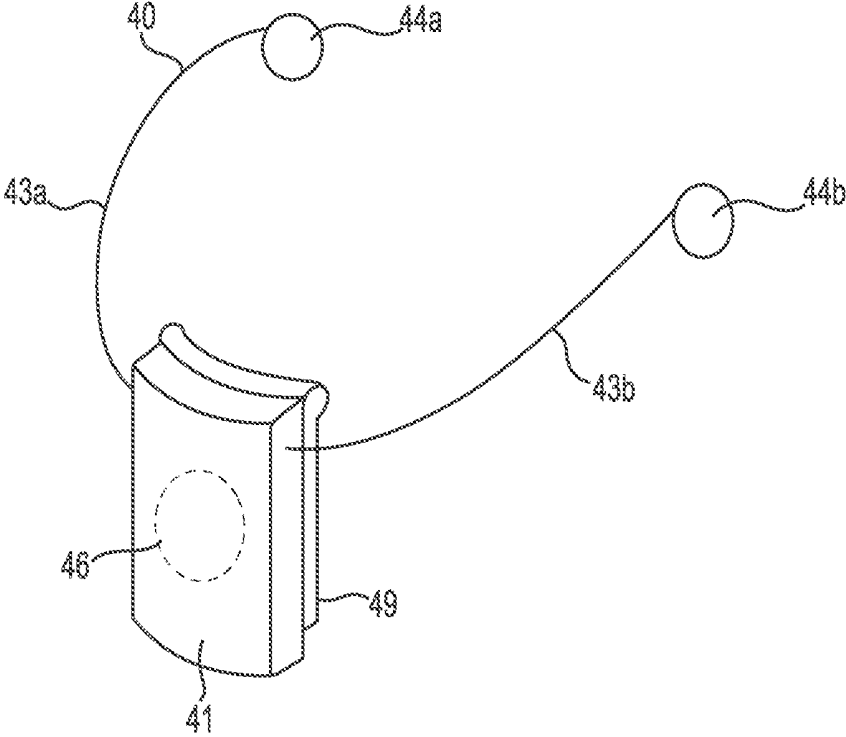

Figure 5

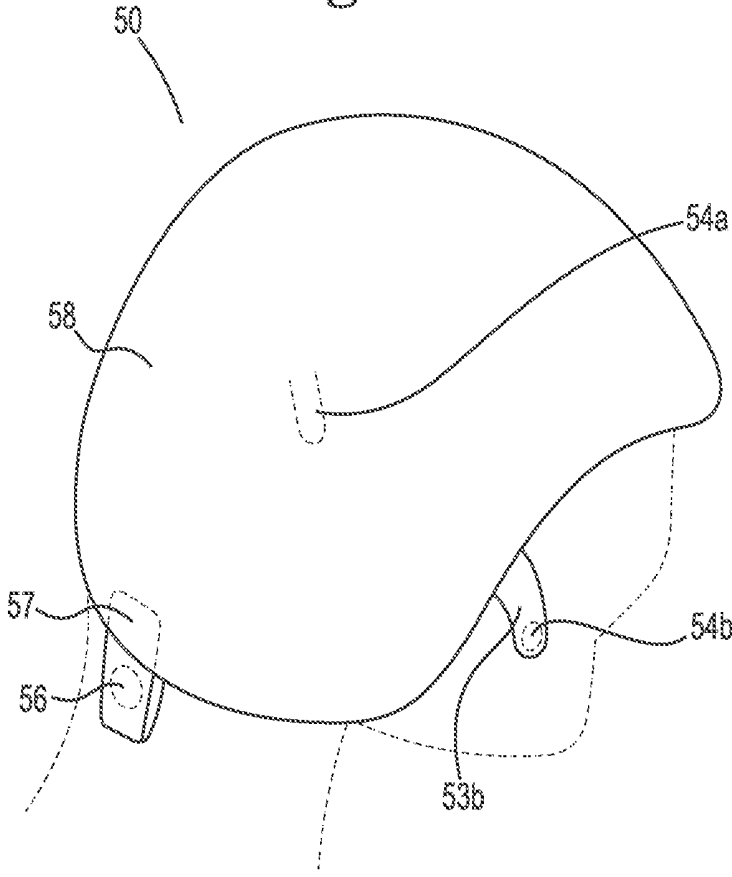

Figure 6

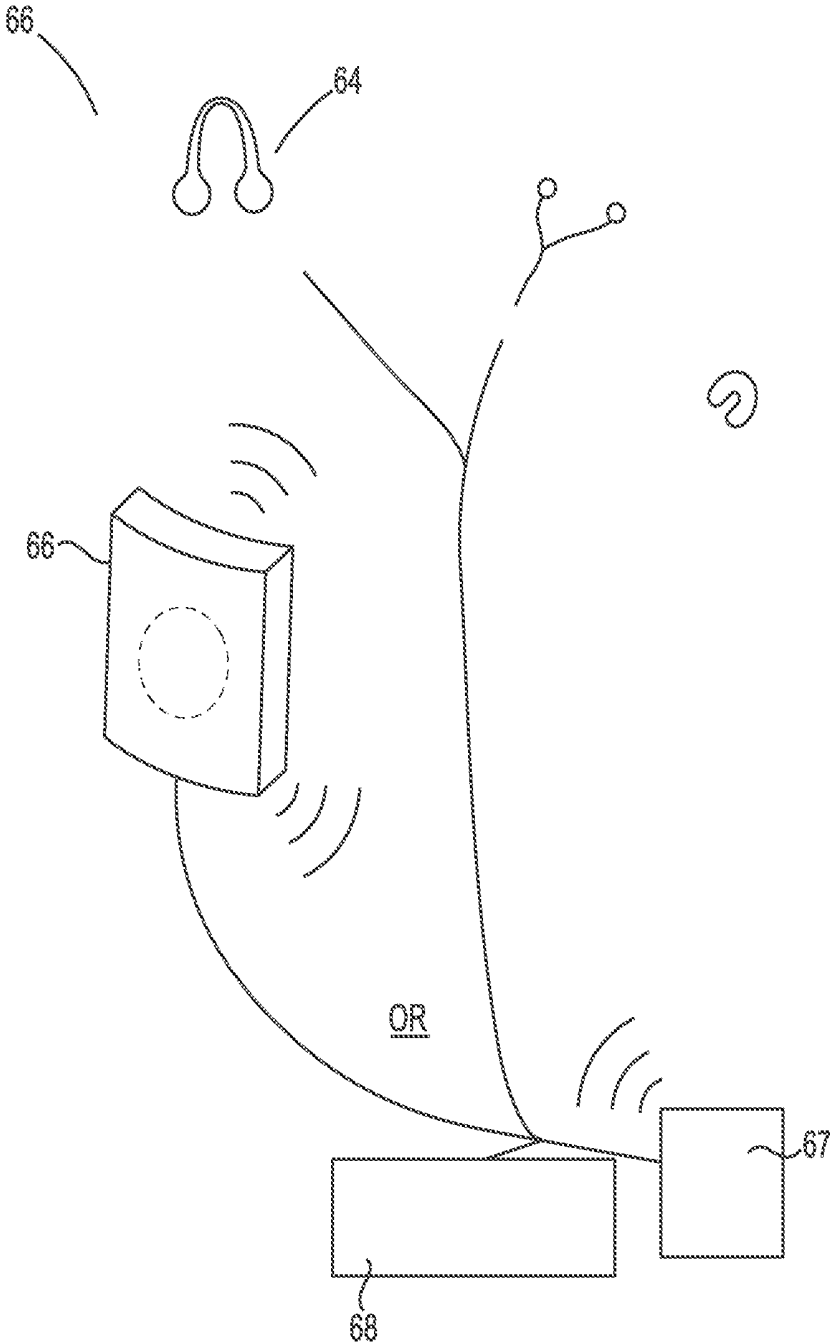

Figure 7A

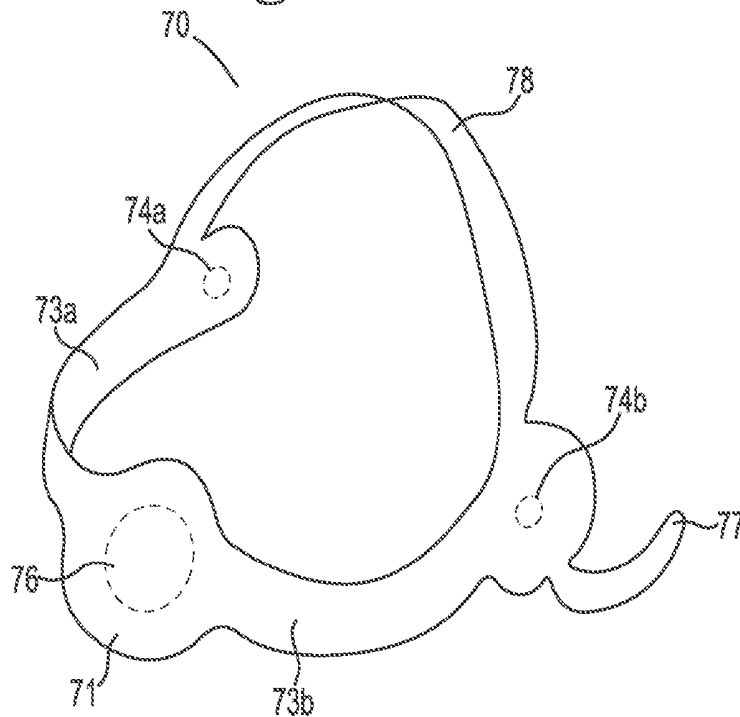

Figure 7B

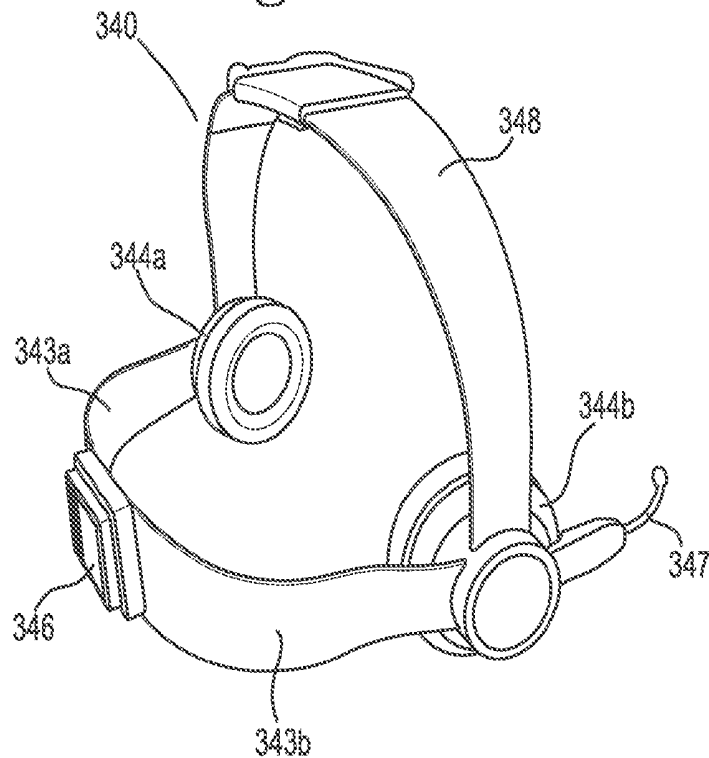

Figure 8A

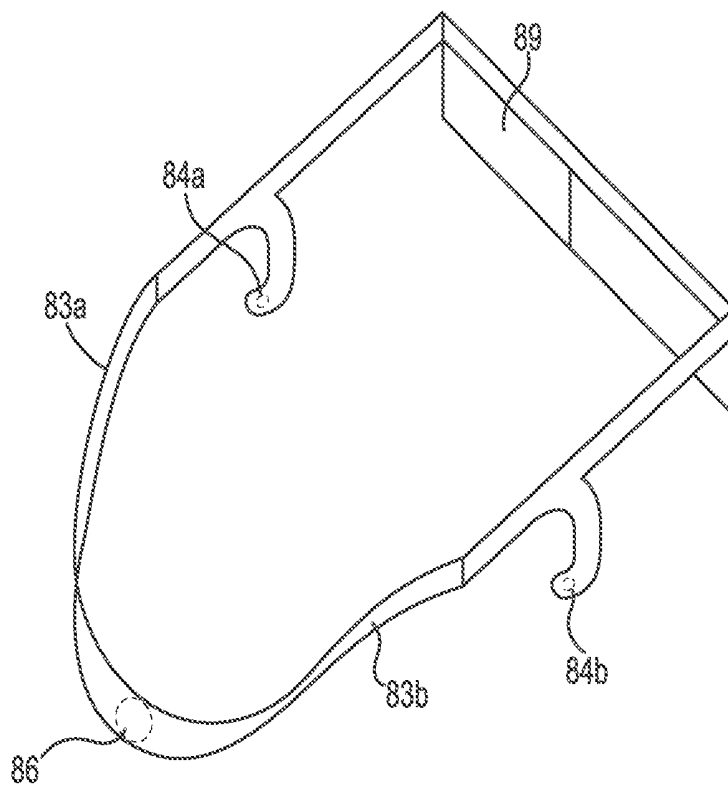

Figure 8B

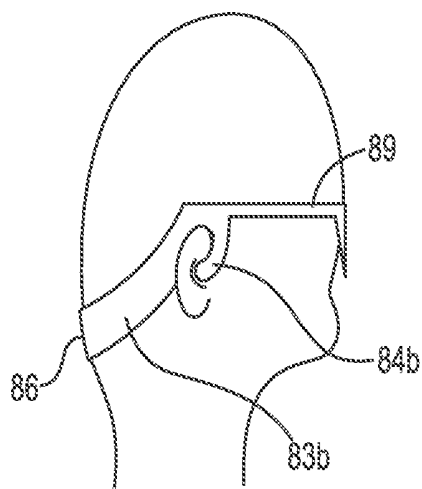
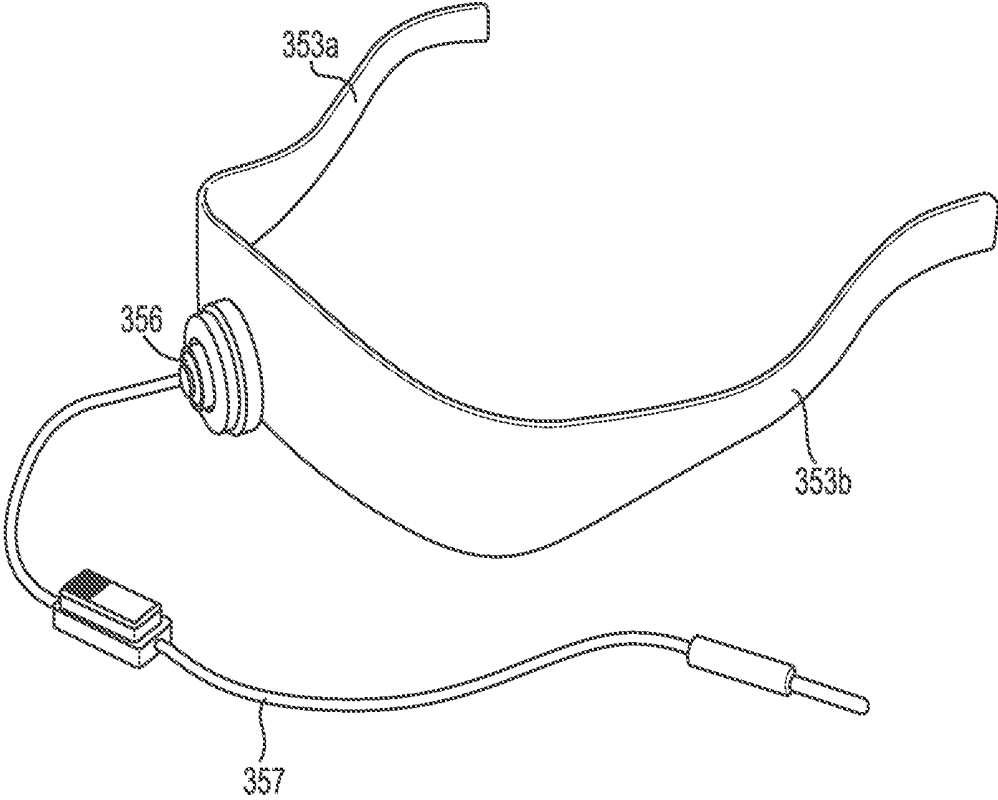

Figure 8C



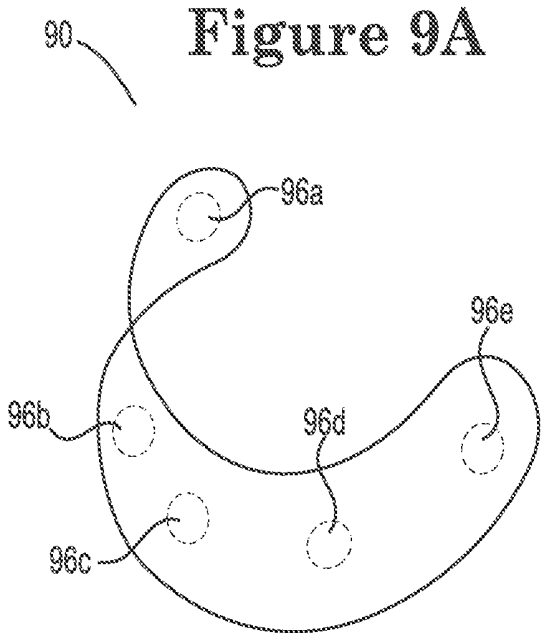

Figure 9B

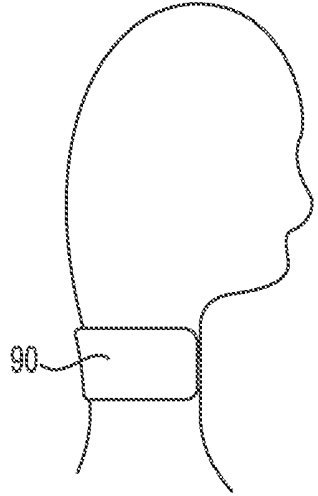

Figure 10

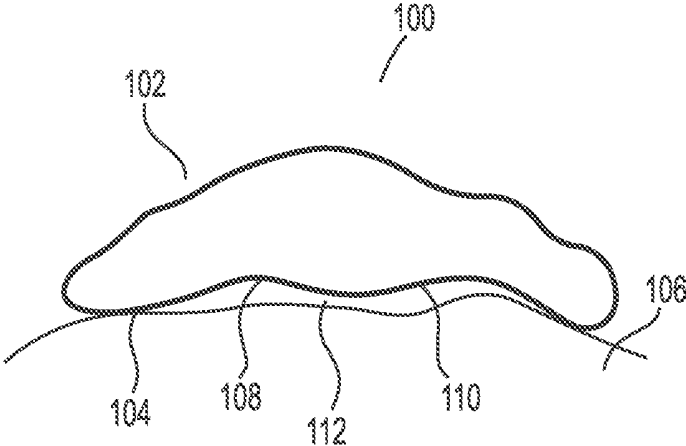

Figure 11

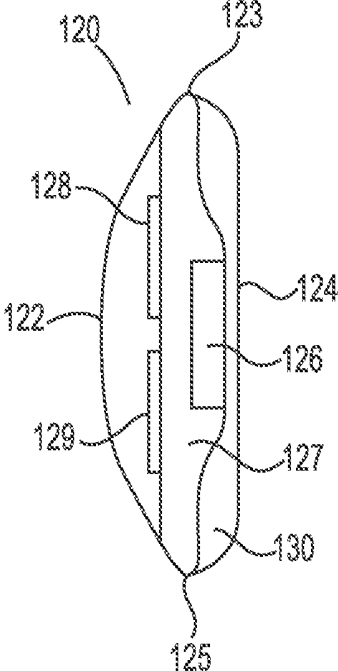

Figure 12A

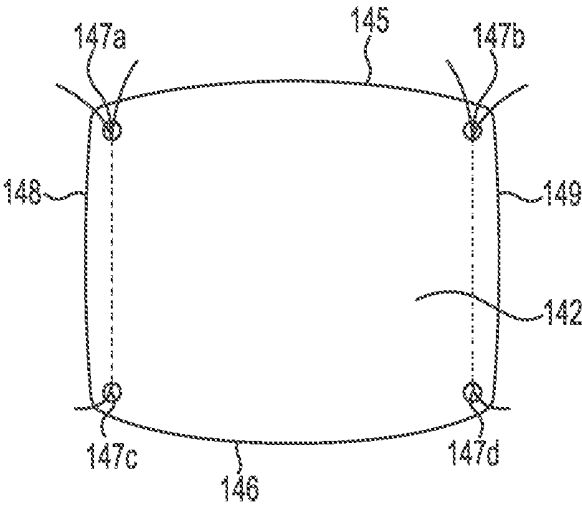

Figure 12B

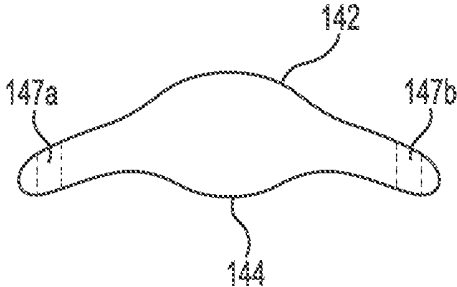

Figure 13A

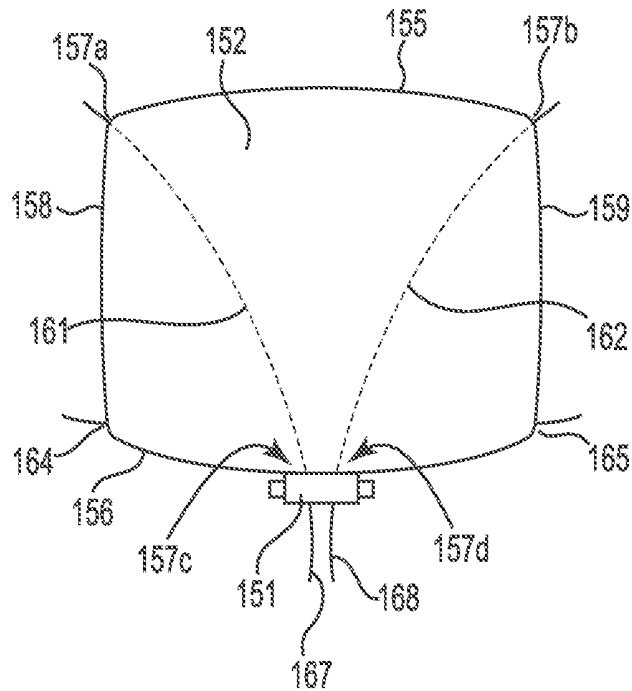

Figure 13B

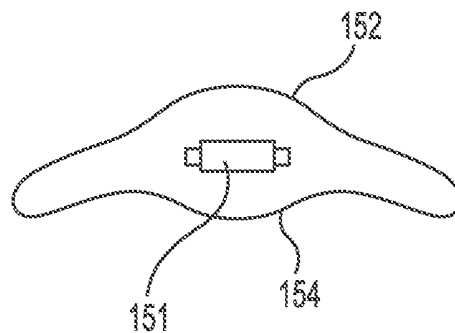

Figure 14A

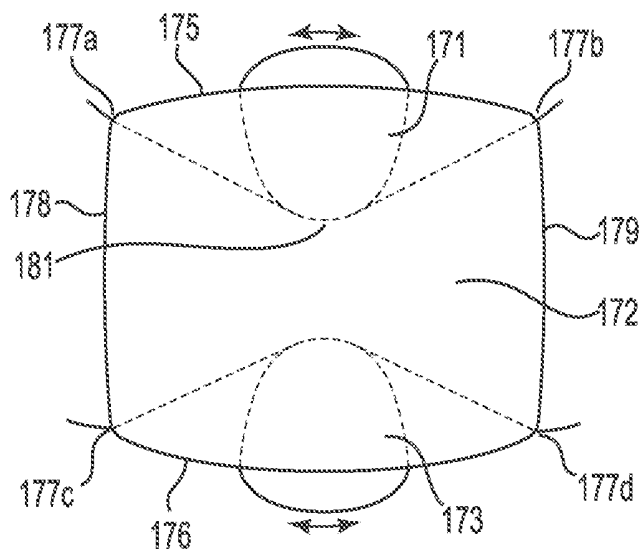

Figure 14B

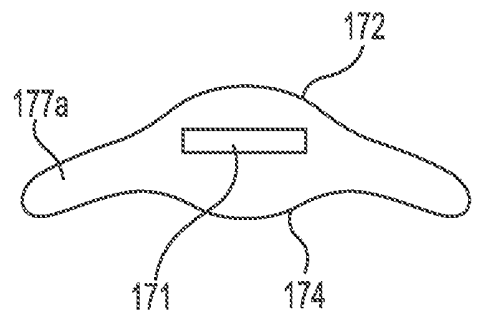

Figure 15A

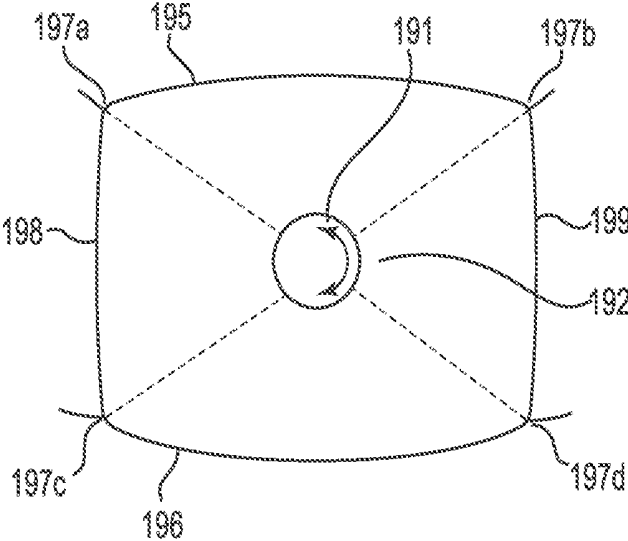

Figure 15B

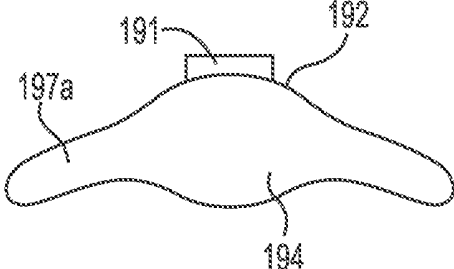

Figure 16A

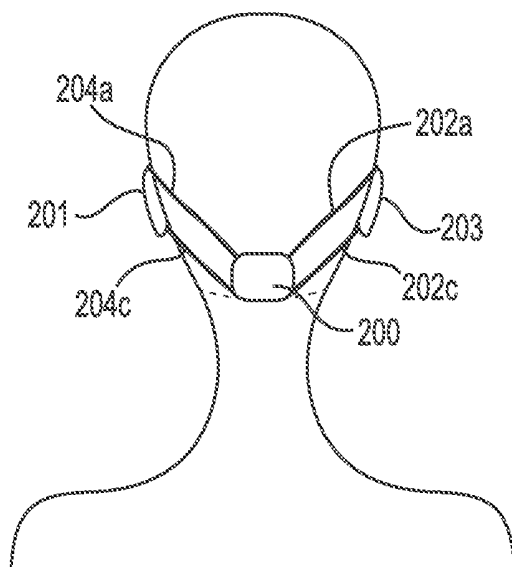

Figure 16B

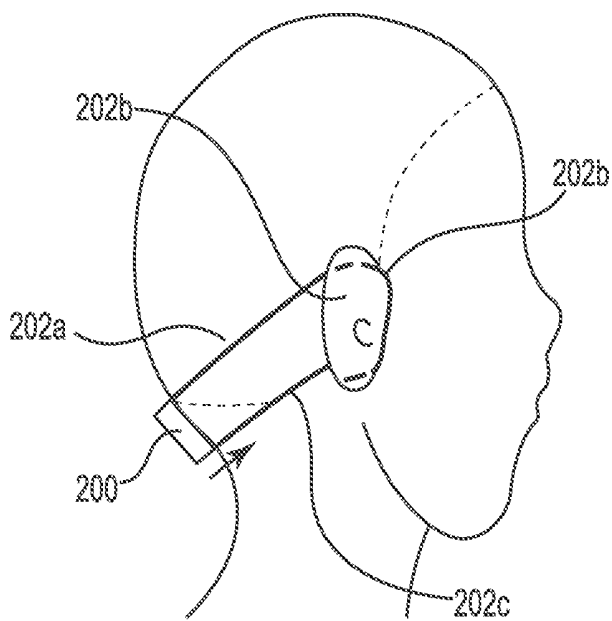

Figure 16C

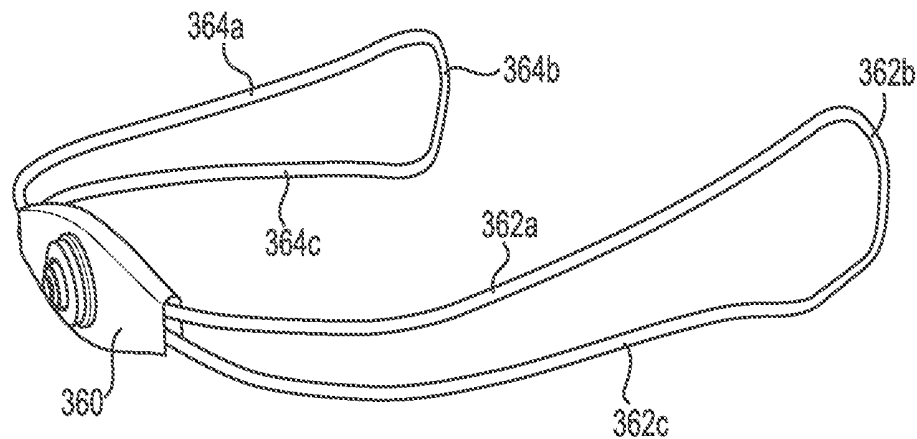

Figure 16D

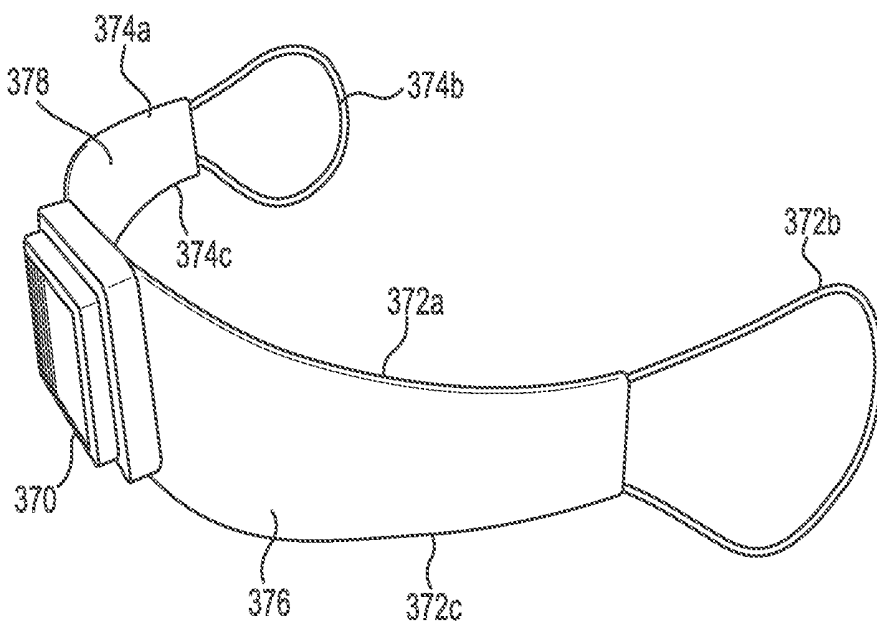

Figure 17A

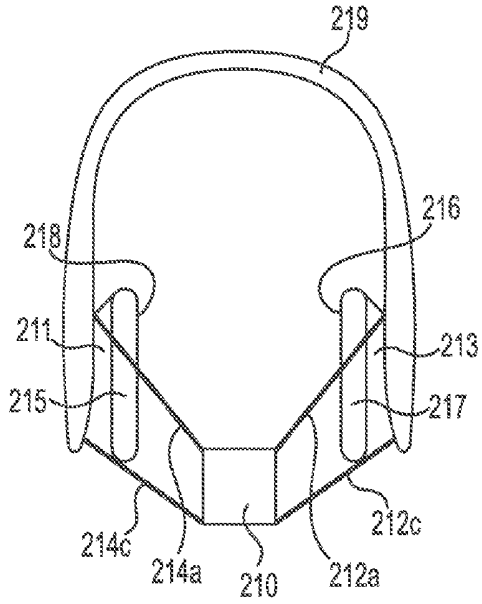

Figure 17B

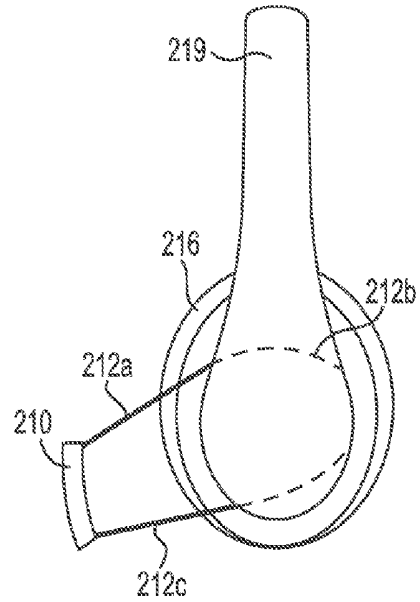

Figure 17C

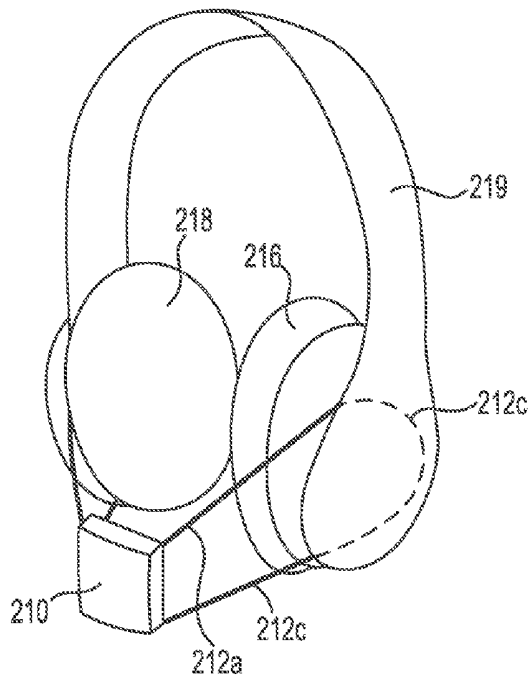

Figure 17D

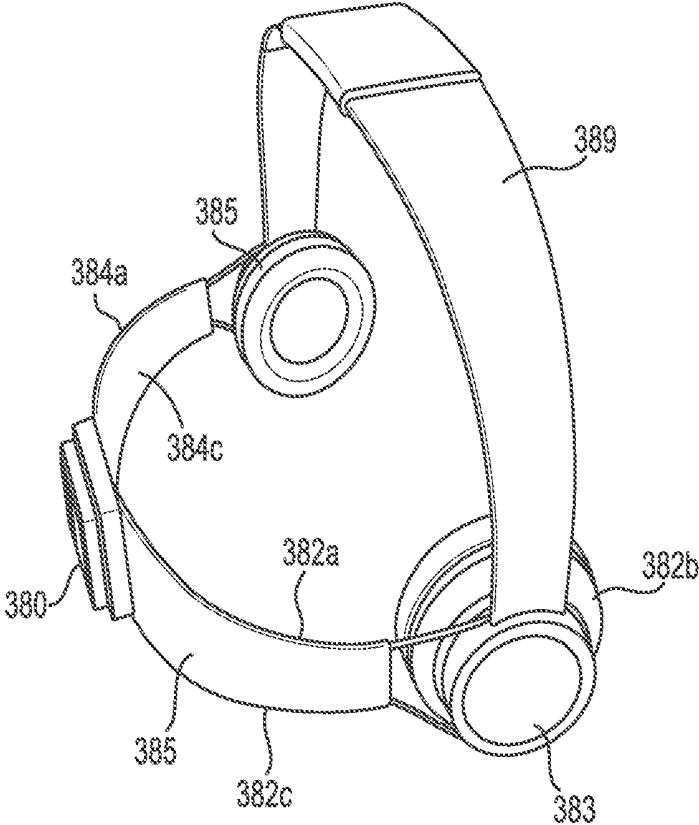

Figure 18A

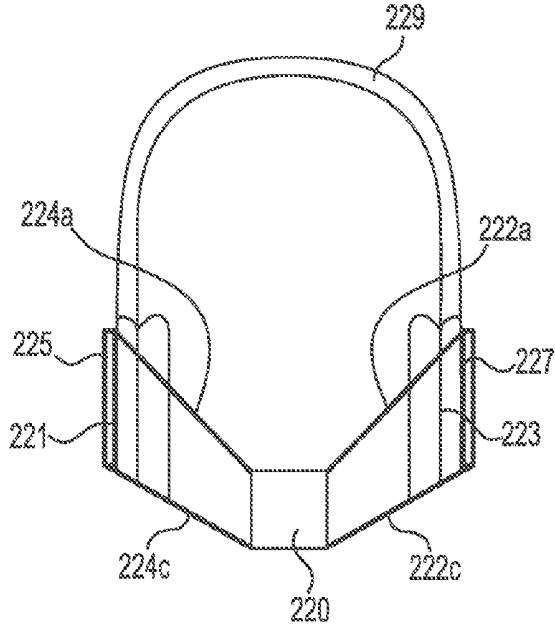

Figure 18B

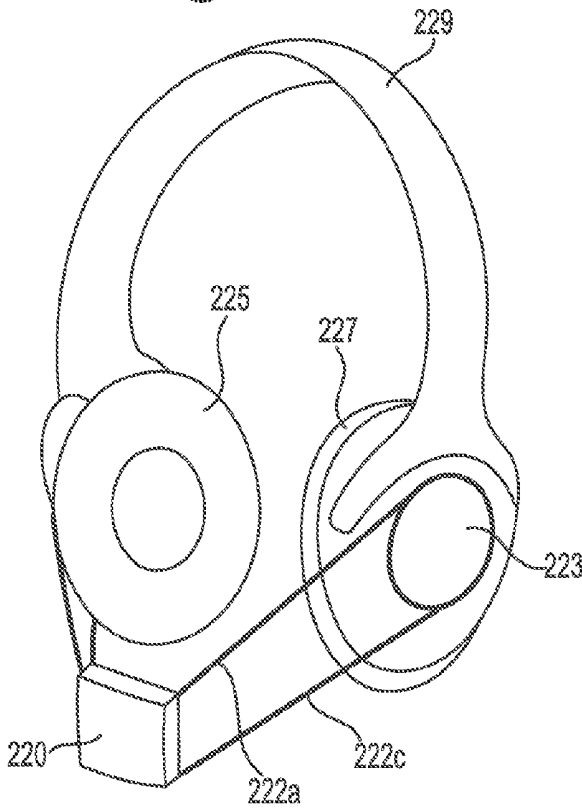

Figure 18C

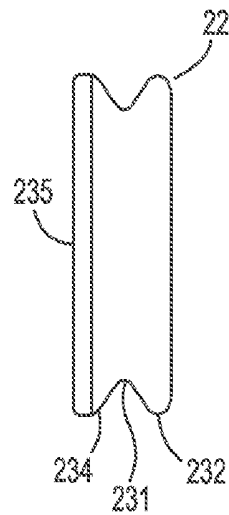

Figure 18D

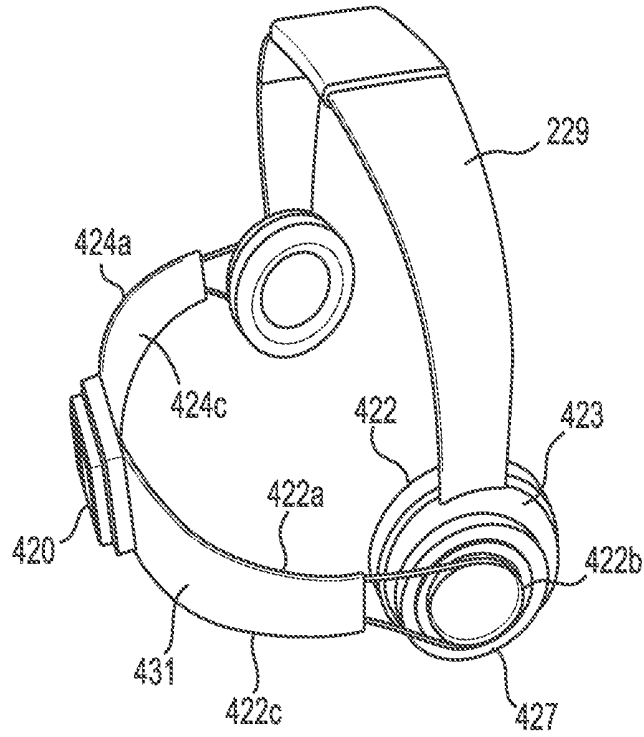

Figure 18E

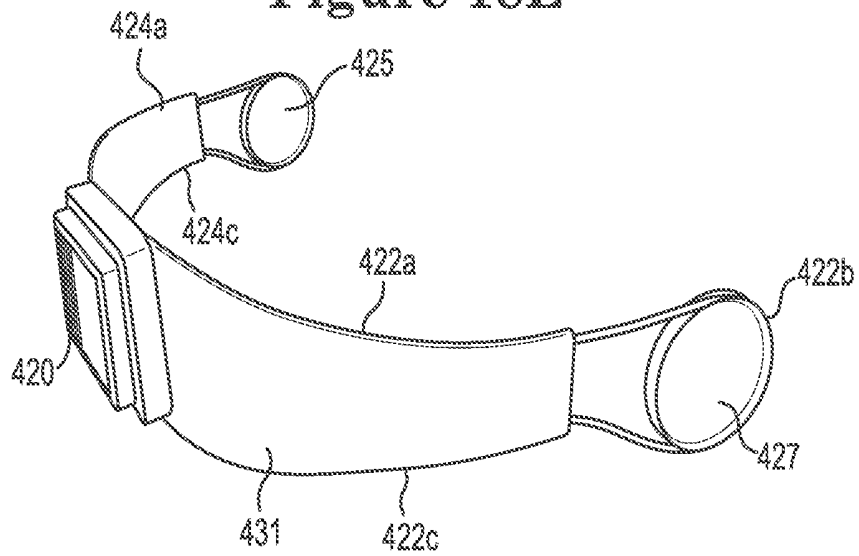

Figure 19A

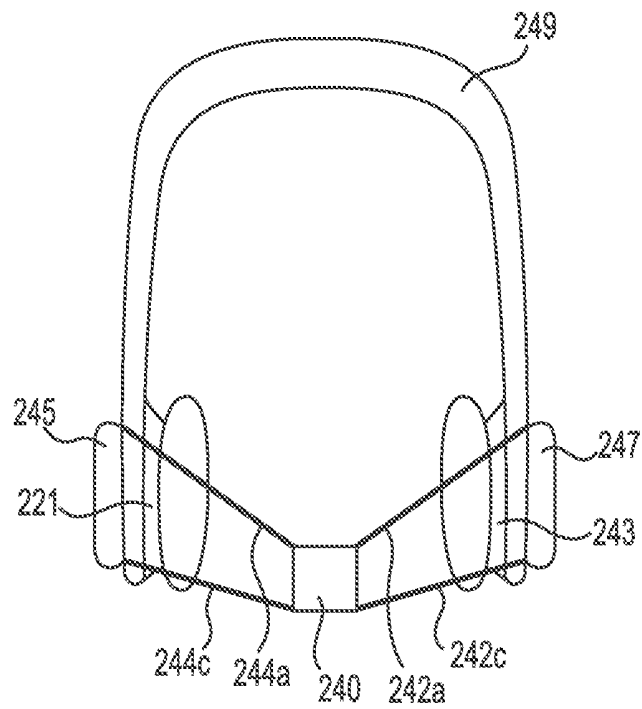

Figure 19B

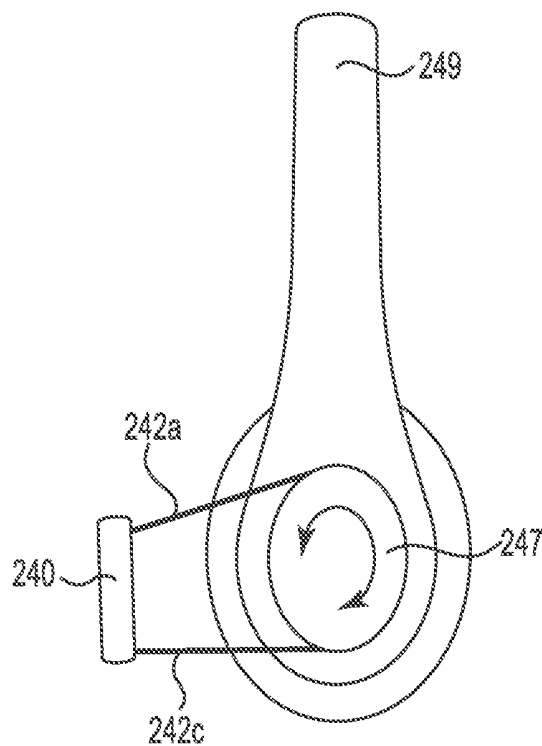

Figure 20A

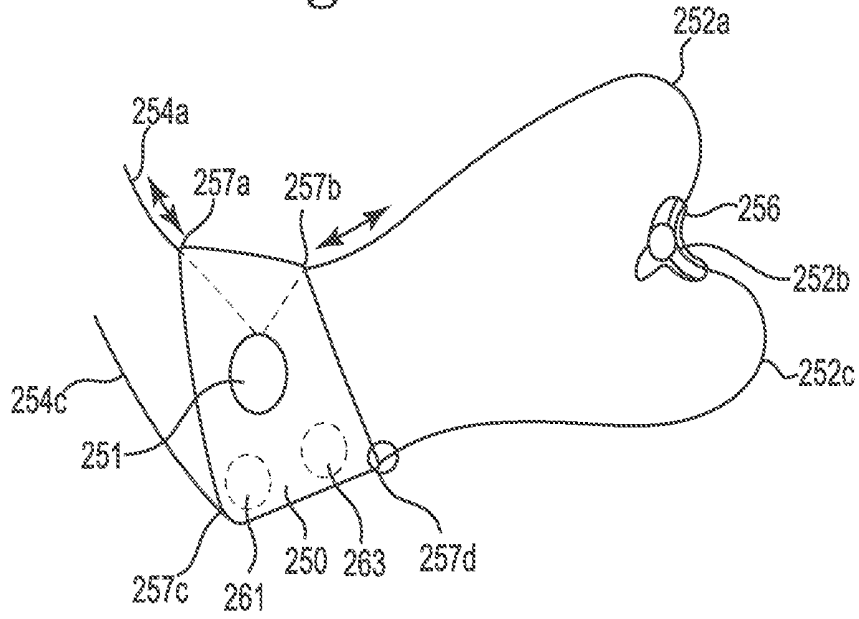

Figure 20B

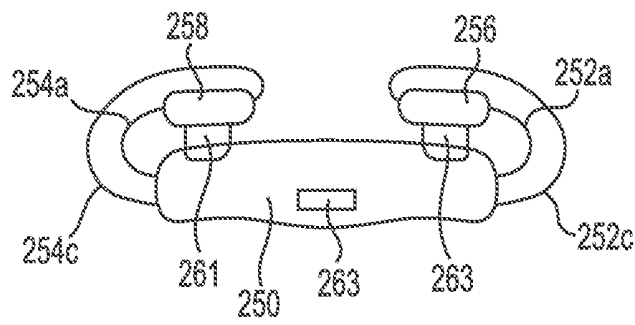

Figure 21

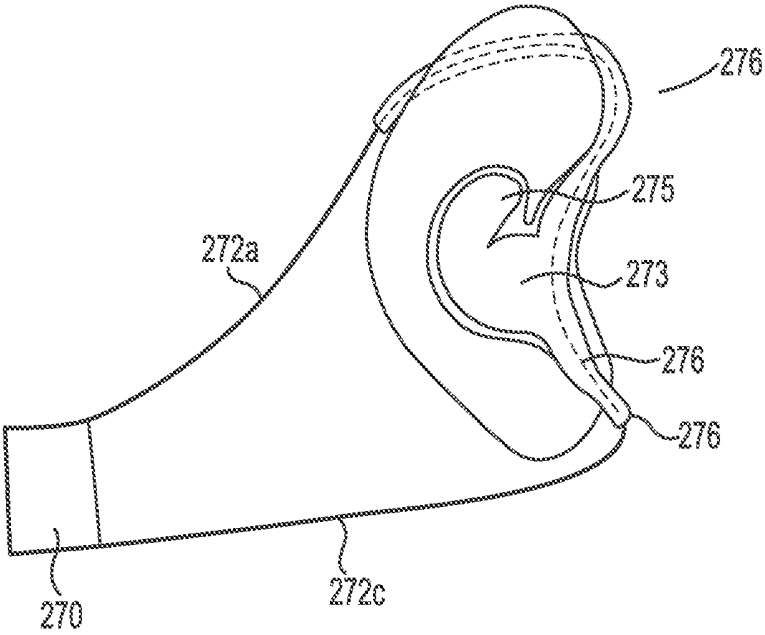

Figure 22A

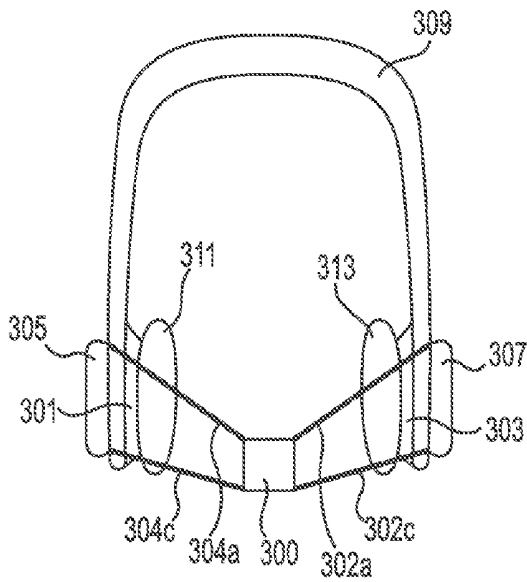

Figure 22B

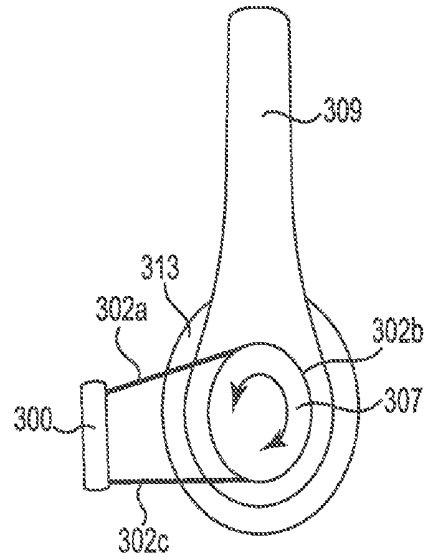

Figure 22C

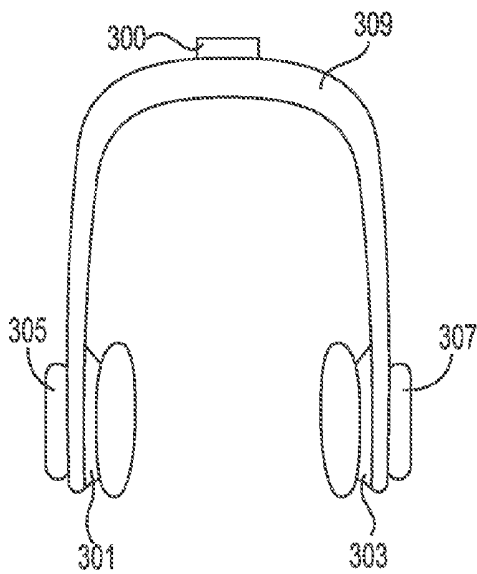

Figure 22D

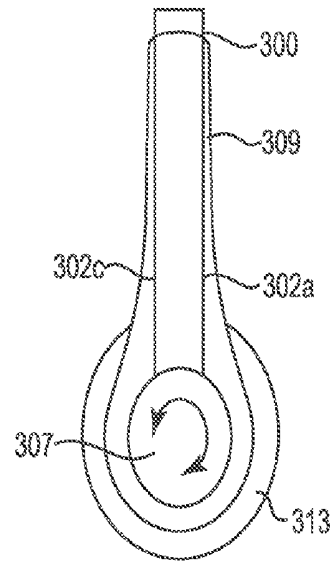

Figure 23

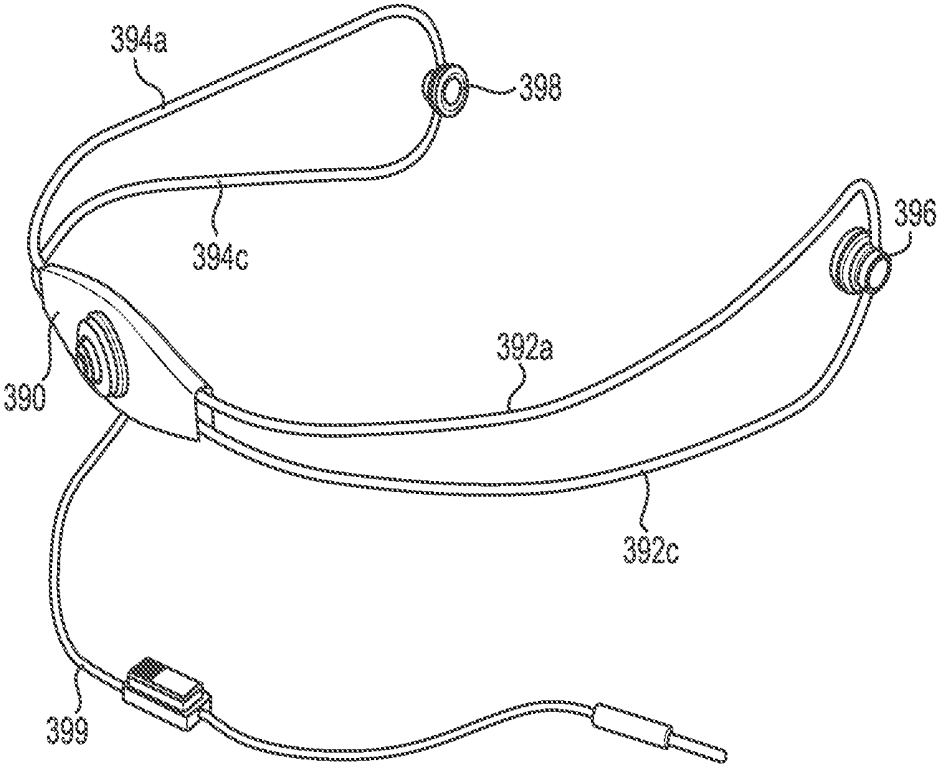

Figure 24

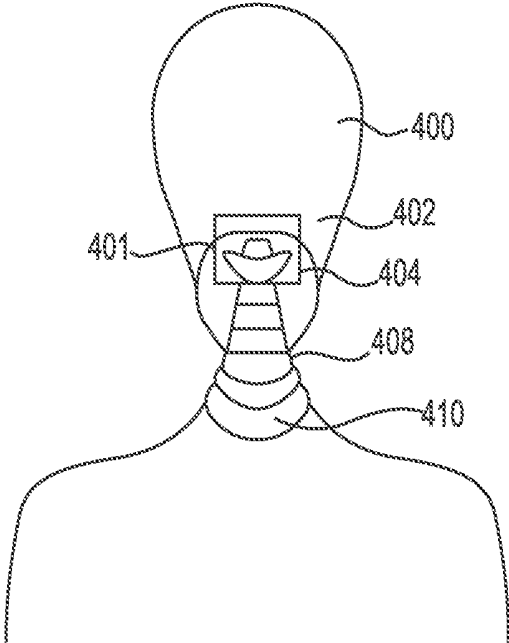

Figure 25

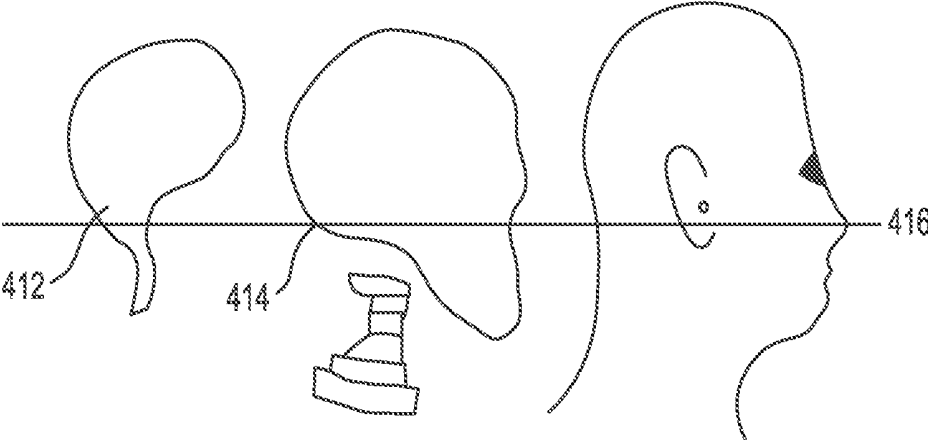

Figure 26

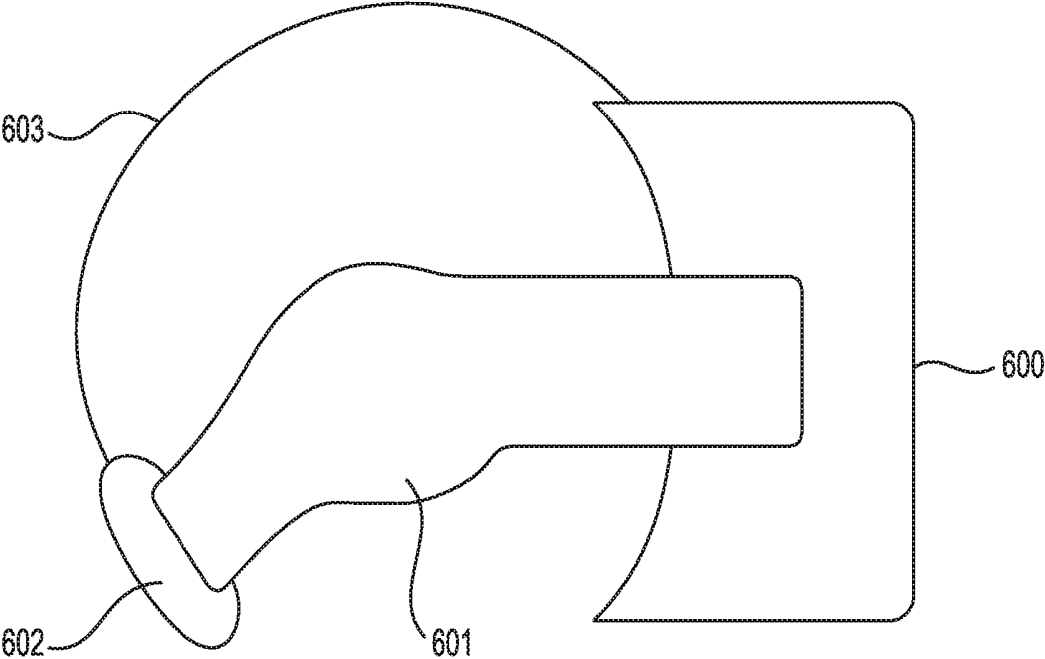

Figure 27

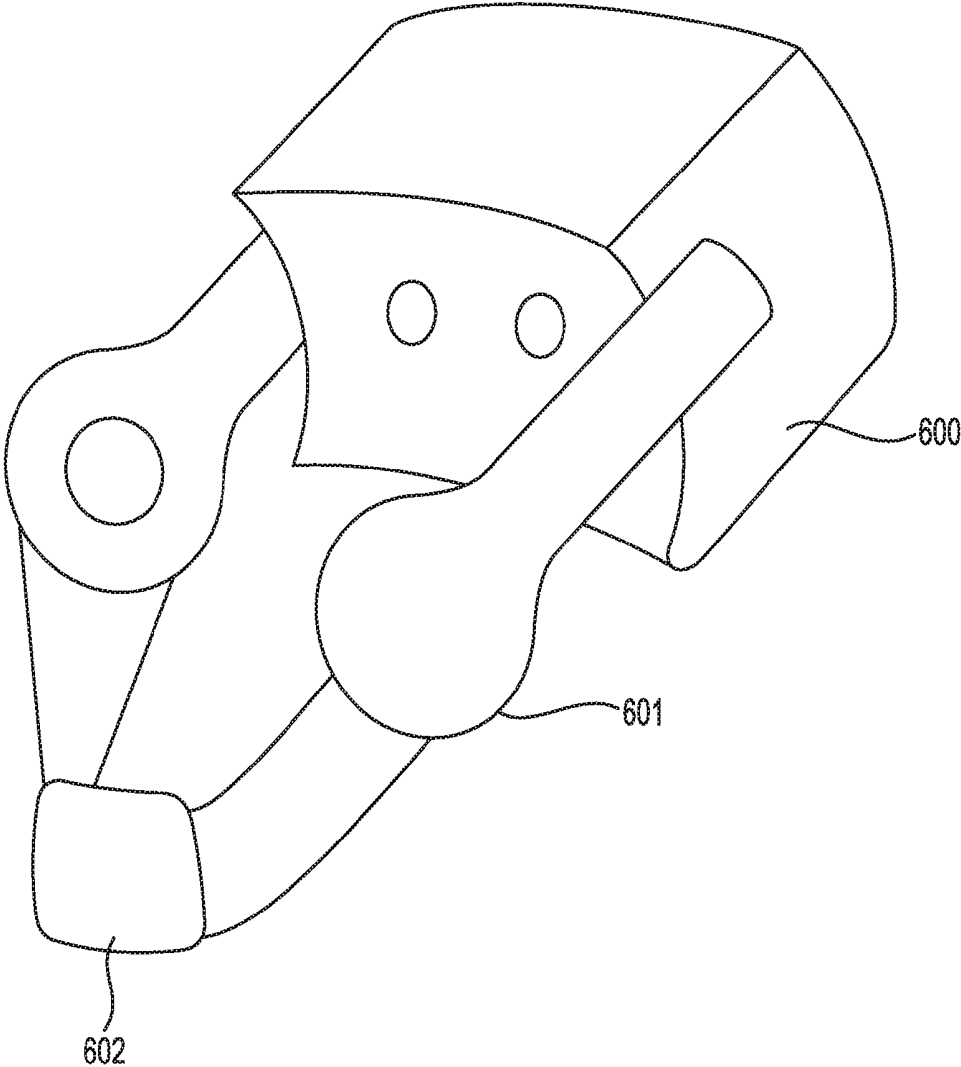

Figure 28

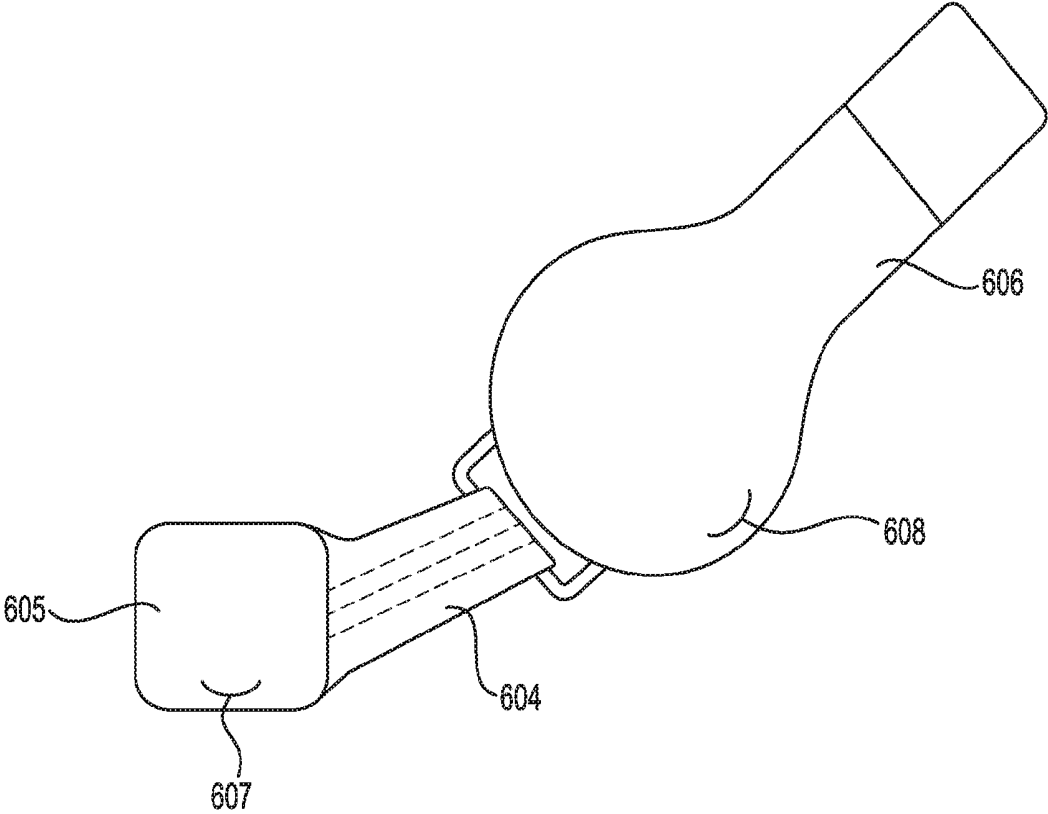

Figure 29

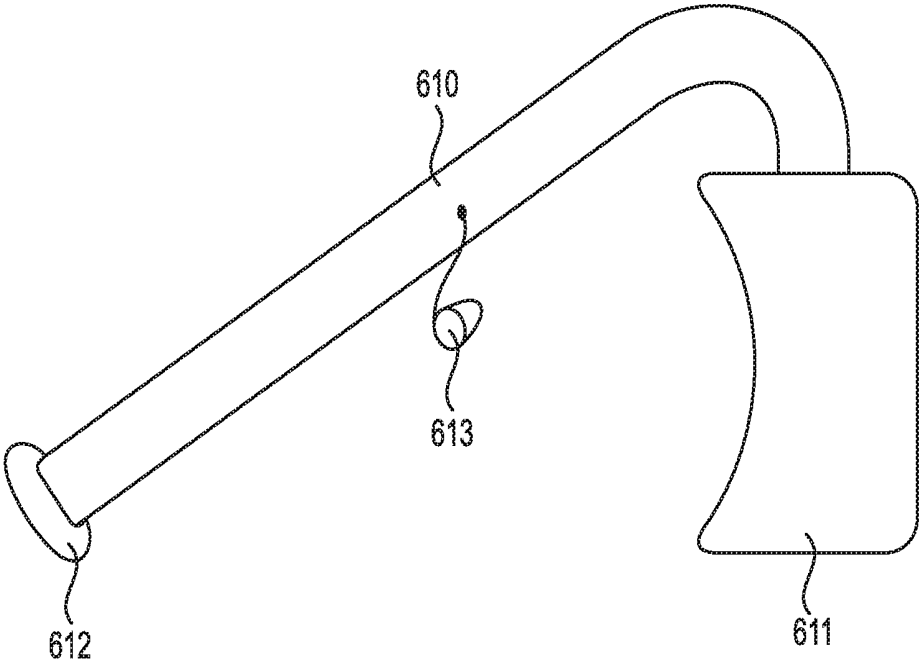

Figure 30

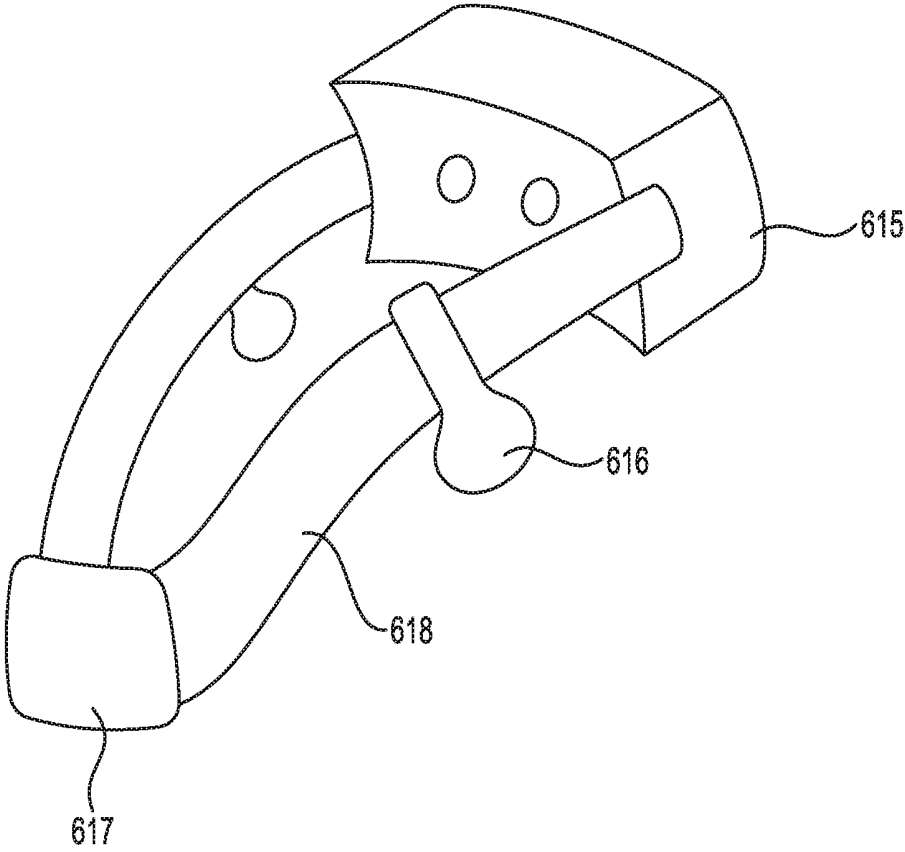

Figure 31

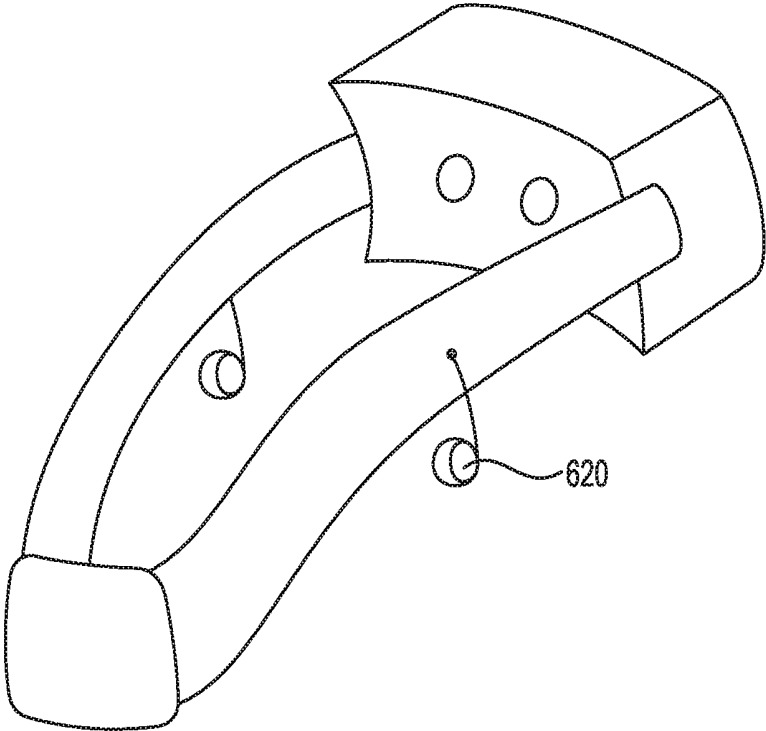

Figure 32

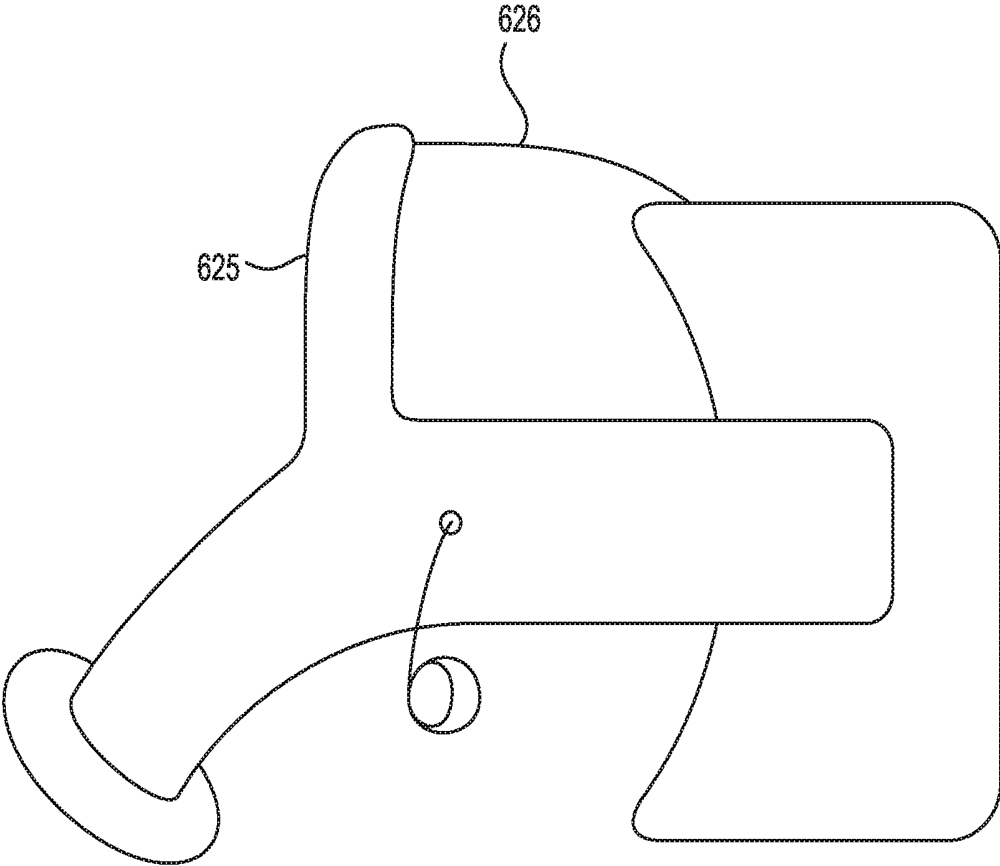

Figure 33

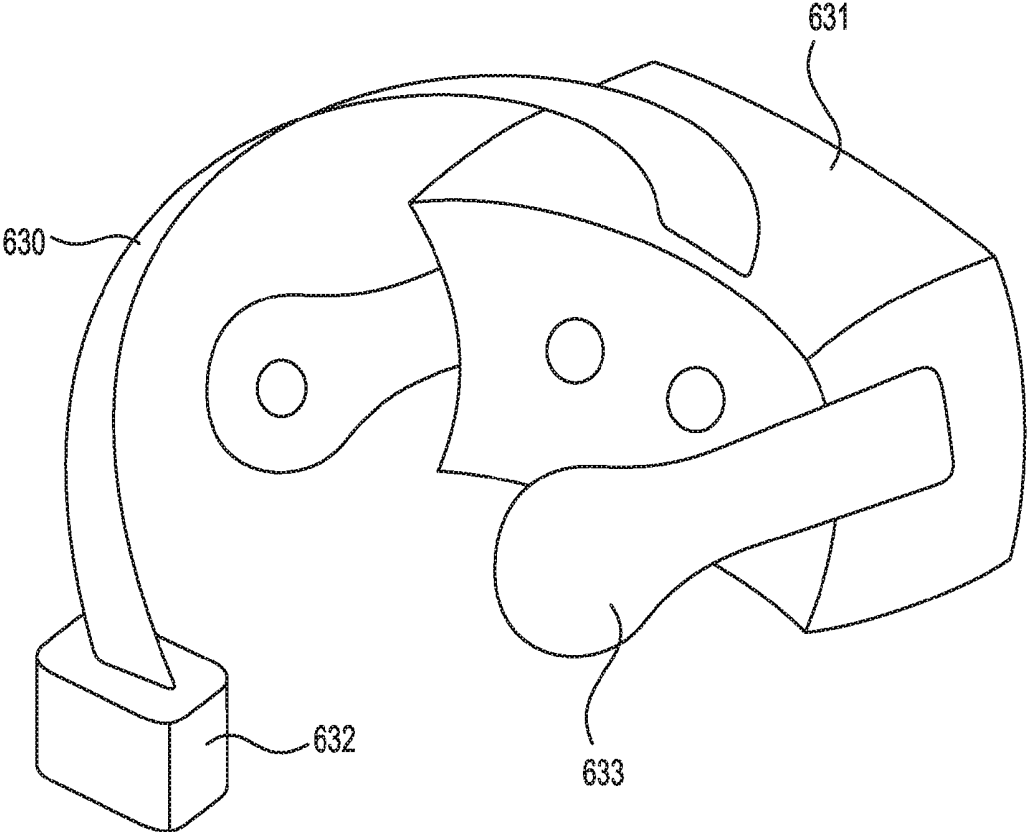

Figure 34

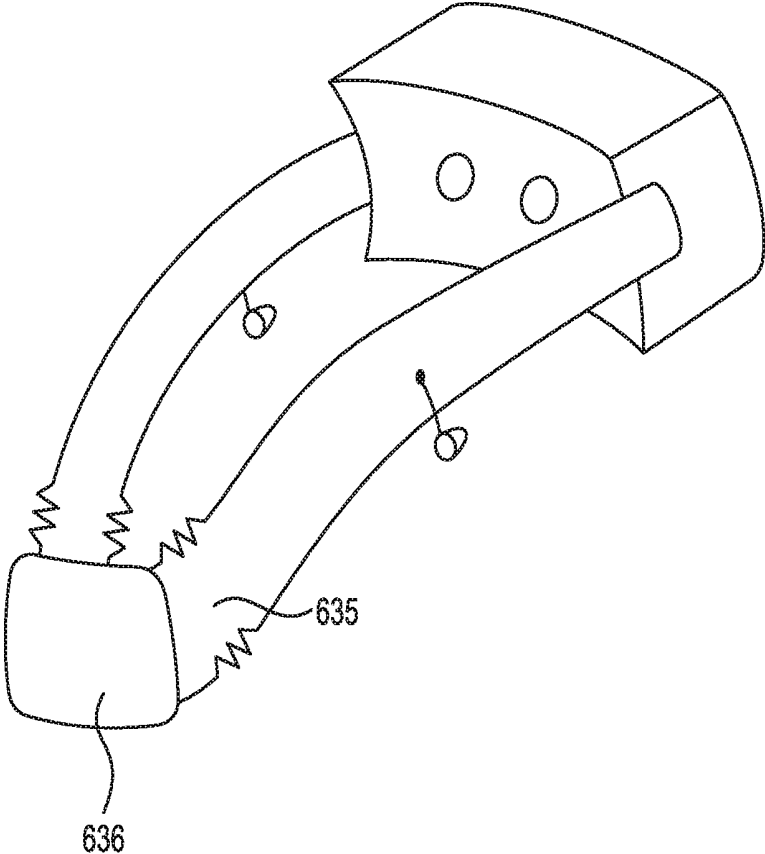

Figure 35

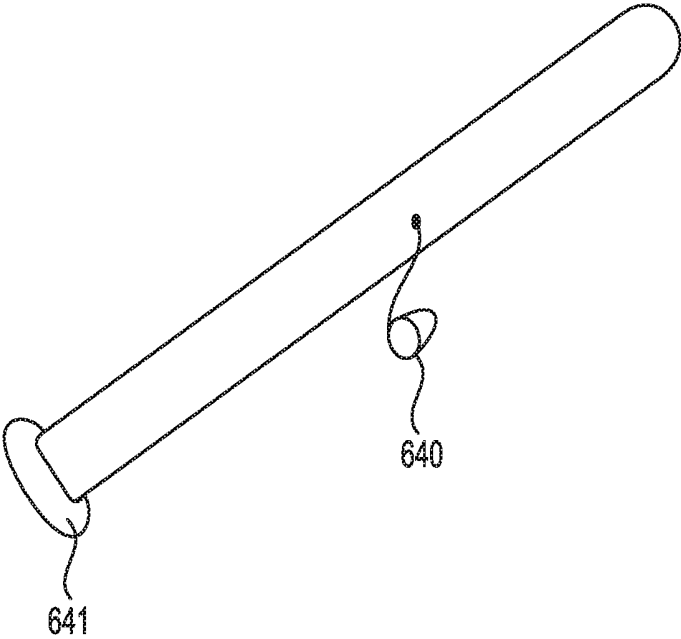
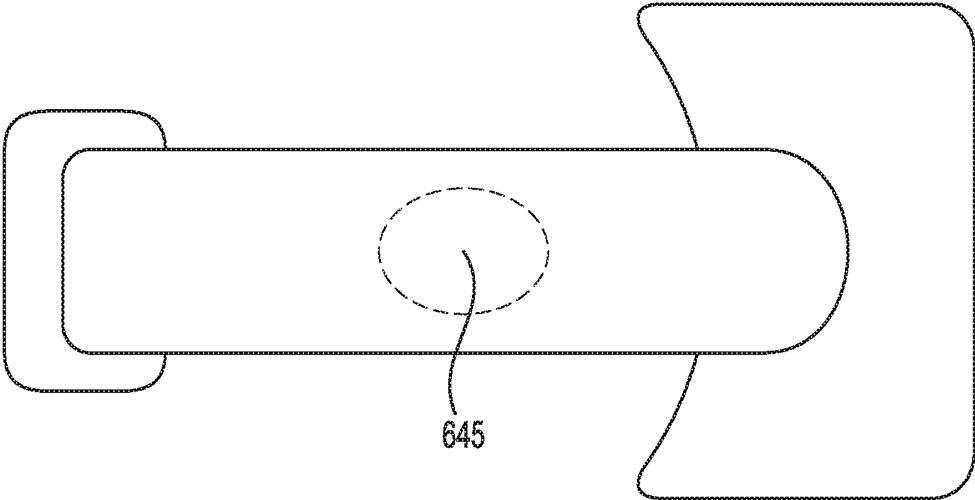

Figure 36



SENSORY STIMULATION OR MONITORING APPARATUS FOR THE BACK OF NECK

PRIORITY

[0001] This application is a continuation-in-part of International Application No. PCT/US2015/021286, filed on Mar. 18, 2015, which claims priority to U.S. Provisional Patent Application No. 61/955,384, filed Mar. 19, 2014, the entire contents of which are incorporated herein by reference in their entireties.

FIELD OF THE INVENTION

[0002] The present invention relates generally to wearable sensory stimulation apparatuses worn on the head and neck.

BACKGROUND OF THE INVENTION

[0003] The human brain is multi-sensory and receives stimulation from the outside world via sound, touch, smell, vision and taste. Commercially available options for delivering and receiving stimulation include headphones or ear buds that deliver audio to the ear, as well as monitoring and sensing apparatuses worn on various parts of the body. Known apparatuses have limitations in their design, function and performance.

SUMMARY OF THE INVENTION

[0004] The various embodiments of the invention relate to apparatuses that improve upon existing sensory stimulation devices such as headphones, ear buds and other wearable headset devices by adding a transduction component to the device, such as vibration speakers, haptic exciters, electrical stimulation, olfactory release, or similar transduction members. The various devices taught herein also include monitoring sensors located on the back of the neck and the spine. These apparatuses can be used to improve audio output performance at lower frequencies, and therefore lower volumes. In an example embodiment, the apparatus is used to train, teach, improve, and recover from athletic performance or activity. In other embodiments, the apparatus is used for entertainment or communication purposes. Alternative embodiments are also used to monitor and diagnose physiological processes, and even deliver forms of sensory stimulation for health, healing or improve coordination purposes.

[0005] The teachings herein improve the performance and experience of existing headphones, ear buds, headsets and other wearable audio delivery devices by adding transduction components such as vibration speakers or similar haptic delivery methods to the system, and placing these components on the back of the neck and/or upper spine of the user. The vibration transduction components allow for better delivery of lower frequencies, especially when in direct contact with the user. This improvement allows lower frequencies to be optimally played, heard and felt through the peripheral sensory nerve pathway, in conjunction with the existing auditory channel, thus more closely resembling larger room speaker output experiences. The wearable audio delivery devices may also be waterproof, adjustable, remote controlled, lightweight, foldable, noise cancellation capable and the like.

[0006] By activating neurologic pathways along the spine, especially cranial nerves, using sound, vibration and music therapy, the user can also receive health benefits. This application provides the embodiments that can be used to

monitor, assess and deliver various forms of vibration therapy to individuals, as well as methods to help coach, train, and recover for improved athletic performance. Additionally, embodiments describe apparatuses that can be used to treat conditions such as tinnitus, Alzheimer's, Parkinson's, autism, or similar brain-related conditions.

[0007] It would be preferable to place a plurality of sensing components on the back of the neck to assess the health condition of the individual. Brain stem activity, heart rate, oxygenation, pulse, movement and other processes may be monitored effectively on the back of the neck. Also, when used in conjunction with the above transduction components, various forms of vibration therapy can be administered, either on the neck, wrist, back, or other points on the body to achieve neurologic stimulation.

[0008] It is taught herein to have a training device for athletic performance such as for golf, baseball, tennis, or other sports. The device can be worn around the neck and over the ears to deliver specific instruction before, during and after the activity. When accompanied by a vibration speaker or similar transducer, the device can stimulate the spine for improved neurologic outcomes. In one example embodiment, the device includes instruction methods, such as swing tempo for golfers, which are loaded on the device and delivered to help train, teach, heal and recover during and after athletic performance or activity.

[0009] Embodiments of the invention set forth a wearable audio delivery apparatus configured for use with a speaker set that is placed in or about the ears, with the apparatus including (a) a housing having at least one vibration speaker or vibration transduction component, the housing configured to be positioned on the back of the neck and on the spine, and (b) right and left attachment members with a proximal portion directly or indirectly connected to the housing, and the attachment members each having a distal portion configured for removable attachment to the ears or to speaker enclosures of a speaker set that is placed about the ears.

[0010] Embodiments of the invention also set forth a wearable audio delivery apparatus that include (a) a speaker set that is placed in or about the ears, (b) a housing having at least one vibration speaker or vibration transduction component, the housing configured to be positioned on the back of the neck and on the spine, and (c) right and left attachment members each comprising a proximal portion directly or indirectly connected to the housing, and a distal portion attached to a portion of a speaker set that is placed in or about the ears, wherein the attachment members are flexible, stretchable, or both flexible and stretchable.

[0011] Embodiments of the invention also set forth a wearable monitoring apparatus that includes (a) a housing having a sensing feature, the housing configured to be positioned on the back of the neck and on the spine, and (b) right and left attachment members directly or indirectly connected to the housing, wherein the attachment members allow the housing to be stably immobilized on the head of a user or to be attached to a headpiece.

[0012] In a related example embodiment and platform, there is provided mobile content delivery systems that allow people to engage with various forms of recorded, digital content while being mobile and wanting to experience the content via as many sensory stimuli as possible. This example embodiment delivers music, gaming, video, therapeutic, or other forms of digital content to entertain, improve or enhance a person's life. Specifically, these related

embodiments encompass various forms of wearable headsets that deliver various forms of multi-sensory stimulation content to users. These mobile headsets deliver content such as audio, video, virtual reality (VR), augmented reality (AR) and mixed reality (MR), allowing the user to hear, feel, see and smell the content. Content can be streamed, uploaded or connected directly to the headsets or components via methods such as smartphones, tablets, hard drives, cables and other connection methods.

[0013] The drawback with existing video headsets is they only deliver one or two sensory stimulation methods, primarily visual and sometimes audio. These existing headsets limit the experience and mobility options consumers have with the digital content. One of the additional characteristics of this embodiment is that it allows the audio signal to be split, filtered, amplified and delivered to multiple speakers and similar audio outputs to provide the user with a more realistic, surround sound experience.

[0014] Articles and types of manufacture, materials, features and advantages of the various embodiments of the invention will become apparent to someone in the art having ordinary skill. It is intended that all such articles included within this description be within the scope of the present invention, and thus protected by the associated claims.

BRIEF DESCRIPTION OF THE DRAWINGS

[0015] Other important advantages of the invention will be apparent from the following detailed description of the invention taken in connection with the accompanying drawings.

[0016] FIGS. 1A-1D illustrate perspective views and a side view of a wearable audio and vibrational delivery or monitoring device that incorporates vibration speakers, other transduction components, and physiological sensors that is placed on the back of the neck;

[0017] FIGS. 2A-2B illustrate perspective and side views of a wearable audio and vibrational delivery or monitoring device that includes an adjustable headband embodiment that is placed over the head;

[0018] FIG. 3 illustrates a wearable audio and vibrational delivery or monitoring device that includes vibration speakers or similar transduction members into headphones that go around the back of the head to the ears;

[0019] FIG. 4 illustrates a wearable audio and vibrational delivery or monitoring device that includes a system of attaching vibration speakers or similar transduction members via a wired or wireless connection, in or over the ear buds, and placed on the back of the neck;

[0020] FIG. 5 illustrates a wearable audio and vibrational delivery or monitoring device that includes vibration speakers or transduction members on the back of the neck and into an audio system built inside a helmet;

[0021] FIG. 6 illustrates a wearable audio and vibrational delivery or monitoring system that includes vibration speakers or transduction members on the back of the neck and is attached with or without wires to headphones to an audio output device, headphones and ear buds;

[0022] FIGS. 7A-7B illustrate perspective views of a wearable audio and vibrational delivery or monitoring device that includes vibration speakers or similar transduction members on the back of the neck;

[0023] FIGS. 8A-8C illustrate perspective views and a side view of a wearable audio and vibrational delivery or

monitoring device that works in conjunction with glasses or goggles or other headgear; and

[0024] FIGS. 9A-9B illustrate perspective and side views of a wearable monitoring device that contains physiological sensors and therapeutic delivery components.

[0025] FIG. 10 illustrates a top view of a housing for a vibration speaker or transduction member placed on the back of the neck.

[0026] FIG. 11 illustrates a cross-sectional side view of a housing for a vibration speaker or transduction member.

[0027] FIGS. 12A and 12B illustrate rear and cross-sectional top views of an embodiment of housing for a vibration speaker or transduction member

[0028] FIGS. 13A and 13B illustrate rear and bottom views of an embodiment of housing for a vibration speaker or transduction member

[0029] FIGS. 14A and 14B illustrate rear and top views of an embodiment of housing for a vibration speaker or transduction member

[0030] FIGS. 15A and 15B illustrate rear and top views of an embodiment of housing for a vibration speaker or transduction member

[0031] FIGS. 16A and 16B illustrate an attachable audio delivery device with housing for placement on the back of the neck, as shown attached to a user's head (back view and side view).

[0032] FIGS. 16C and 16D illustrate embodiments of an attachable audio delivery device with housing for placement on the back of the neck.

[0033] FIGS. 17A-17D are front, side and perspective views of embodiments of an attachable audio delivery device with housing for placement on the back of the neck and a view of the device attached to speaker enclosures of a headphone set.

[0034] FIGS. 18A-18E are front, perspective and side views of embodiments of an attachable audio delivery device with housing for placement on the back of the neck and a perspective view of the device attached to a headphone set.

[0035] FIGS. 19A-19B are front and side views of another embodiment of an attachable audio delivery device with housing for placement on the back of the neck attached to a headphone set.

[0036] FIGS. 20A-20B are illustrations, respectively, of an integrated audio delivery device including a housing for placement on the back of the neck and earbuds and the delivery device in a storage configuration for battery recharging.

[0037] FIG. 21 is an illustration of an earbud construction for an integrated audio delivery device.

[0038] FIGS. 22A-22D are front and right side views of an integrated audio delivery device with and without a housing for placement on the back of the neck with a headphone set.

[0039] FIG. 23 is an illustration of an integrated audio delivery device including a housing for placement on the back of the neck and earbuds.

[0040] FIG. 24 illustrates anatomical features of the upper body relevant for placement of an audio delivery device or device having a sensing mechanism.

[0041] FIG. 25 illustrates anatomical features of the upper body including relevant for placement of an audio delivery device or device having a sensing mechanism.

[0042] FIG. 26 illustrates a side view of a mobile content delivery headset.

[0043] FIG. 27 illustrates a perspective view of a mobile content delivery headset.

[0044] FIG. 28 illustrates a side view with details of a component attached to a mobile content delivery headset arm.

[0045] FIG. 29 illustrates a side view of another mobile content delivery headset with a different shape.

[0046] FIG. 30 illustrates a perspective view of a mobile content delivery headset that has a conforming shape to a user's head and speakers adjacent a user's ears.

[0047] FIG. 31 illustrates similar headset to FIG. 30 with in-ear speakers for a user.

[0048] FIG. 32 illustrates a side view of a mobile content delivery headset that incorporates an over the head attachment to hold an eyepiece or viewing display in place.

[0049] FIG. 33 illustrates a perspective view of a mobile content delivery headset with an over the top of the head design.

[0050] FIG. 34 illustrates a mobile content delivery headset with features that allow components to adjust, conform and move independent of each other.

[0051] FIG. 35 illustrates a mobile content delivery headset, similar to FIG. 29, but without the eyepiece or viewing display.

[0052] FIG. 36 illustrates a mobile content delivery headset with speakers directly over the ears.

DETAILED DESCRIPTION OF THE INVENTION

[0053] The detailed description that follows below is intended to provide illustration to the principles of the invention. This description is not provided to limit the possibilities of the invention described herein, but rather to explain and teach the principles in such a way that a person of ordinary skill in the art could apply them to practice not only to the embodiments described herein, but also to other embodiments that could come into mind when applying the principles. The intention is to not limit the disclosures and claims listed herein, but to also include all similar embodiments.

[0054] The various embodiments described herein detail improvements to currently available devices, such as headphones, ear buds, headsets, headbands, glasses, and the like, that are worn by humans to deliver sound. By including additional speakers or other haptic transducers to these devices, and placing them around the back of the neck along and in contact with the spine, allows lower frequencies to be played more effectively, and can be heard and felt at the same time, thus improving audio output performance. Musicians, disc jockeys and audiophiles will be able to enhance the audio output. In a related embodiment, video gamers will also enjoy an enhanced experience with the improved audio device taught herein. Features such as waterproof, adjustable, remote control, volume control, lightweight, foldable, noise cancellation and the like may also be included.

[0055] Additionally, since the neck is an ideal location to assess the health of a human, it is also envisioned that physiological health monitoring sensors may be incorporated into the systems, thus allowing users to track brain activity, movement, heart rate, blood pressure, glucose output and similar bodily functions. In an example embodiment, the device is capable of delivering this information to a user's computer or smartphone. These assessments could

be used in conjunction with the delivery of therapy through transduction members also placed within the wearable devices on the back of the neck and used to stimulate the nervous system throughout the body.

[0056] Also, it is taught herein that the device is capable of incorporating teaching, training, and recovery regimens into the delivery device and worn on the back of the neck. This placement keeps the unit out of the way, allows for focus since it covers the ears, and delivers therapy along the spine before, during, and after performance needs. The device may be used for athletic activities, such as golf, baseball, tennis, bicycling, and other sports. When combined with the various forms of vibration delivery, improvements such as balance, stability, hand/eye coordination, muscle firing, and other neurologic processes are expected.

[0057] Additionally, placing optional sensing mechanisms within one or more embodiments allows the accurate assessment of physiological processes such as heart rate, blood flow, blood pressure, brain stem activity, and user activity. This monitoring functionality is used to not only assess health and deliver that output to the user, but also can be connected to wearable forms of delivering therapy through the transduction components. Example benefits of this embodiment allow for users to wear the headphones to assess conditions associated with aging, such as balance or stability issues, anxiety, fatigue, lack of mobility or pain, and deliver a sensory therapy to help correct or address these symptoms.

[0058] Also, throughout the disclosure various embodiments are described that include a vibratory or audio transducer component(s) placed inside of a housing, which is configured for placement on back of the neck. It is envisioned that the vibratory or audio transducer component in any of the disclosed embodiments could be supplemented with or replaced by other non-audio or non-vibrational stimulation components to provide a stimulatory effect to a user to achieve a desired outcome. Exemplary non-audio or non-vibrational stimulation components include but are not limited to electrical stimulation, transcutaneous electrical nerve stimulation (TENS), extracorporeal shock wave therapy (ESWT), olfactory or pheromone stimulation.

[0059] FIG. 6 illustrates a system 60 with components for wearable audio delivery and/or monitoring that can include a vibration speaker 66 or similar transduction members, and/or monitoring sensors, configured for placement on the back of the neck. The vibration speaker 66 can be attached either with or without wires (wirelessly) to headphones 64 to an audio output device 67, headphones and ear buds. The wearable audio delivery and monitoring device 60 can include a splitter jack 68 that allows the device to be connected to both the ear buds 30 and vibrational speakers 20.

[0060] In some embodiments the vibration transduction component that provides lower frequency output is an "add-on" component, meaning that is provided apart, i.e., as a separate component, from a headphone or earbud speaker set that the user may already possess. In this embodiment, the audio delivery apparatus can be referred to as configured for the "removable attachment" to the ears, or to speaker enclosures of a speaker set that is placed about the ears. In order to explain aspects of the invention, features of commercially available over the ear-type headphones and earbud-type headphones, and which can be used with an

“attachable” audio delivery apparatus including vibration speaker or vibration transduction component, are described.

[0061] Commercially available “over the ear” headphones (herein referred to as “headphones”) generally include a pair of small loudspeakers within an enclosure or housing that is held in place over a user’s ears. Typically the speaker enclosures are attached to a band that goes over the user’s head and that provides a slight inward force to press the enclosures up against the user’s ears, which aid in providing stability during use. Speaker enclosures generally include padding, such as a foam material covering all or a portion (such as about the periphery) of the inner (user) side of the enclosure to improve the comfort of the headphones. Typically, the band over the top of the user’s head is adjustable to provide desired placement of the speaker enclosures. Commercially available speaker enclosures of headphones are of various shapes and sizes. Common shapes for speaker enclosures include oval, circular, and oblong shapes. The size of such enclosures can be somewhat small, such as less than the size of the outer ear of a user, or can be rather large and have a periphery that is larger than the outer ear. For example, the periphery of a speaker enclosure of a headphone may be in the range of about 10 cm to about 30 cm, or about 15 cm to about 25 cm.

[0062] Other commercially available speaker sets for use on the head include earphones (referred to herein as “earbuds”) and in-ear headphones (also referred to as “in-ear monitors,” (IEMs) or “canalphones”). Earbuds are very small speaker enclosures that are configured to fit within the outer ear, and which face but are not inserted into the ear canal. Earbuds typically include a soft firm material, such as a foam pad, on the ear-canal facing surface to provide comfort. In-ear headphones have a speaker enclosure that is configured to extend into the ear canal. In-ear headphones can be generic or custom fitted, and made from materials such as silicone rubber, elastomers, and foam. Speakers found within headphones, earbuds, and in-ear headphones are electroacoustic transducers which convert an electrical signal to a corresponding audio wave which provides a sound in the user’s ear. Typical speakers within headphones, earbuds, and in-ear headphones provide an audio signal generally over a broad frequency range, for example in the range of about 20 Hz (very low bass tones) to about 20,000 Hz (the highest treble), which represent the lower and upper ends, respectively, of what the human ear can detect. However, unlike low frequency speaker systems, the output of commercial headphones, earbuds, and in-ear headphones is desirably equally distributed over the broad frequency range.

[0063] In contrast to speakers found within headphones, earbuds, and in-ear headphones the vibration speaker or vibration transduction component of the current disclosure can provide a low frequency output to create vibration on the back of the neck and over the spine. The vibration speaker or vibration transduction component can be used with the attachment embodiments and integrated embodiments of the invention. In some aspects, the apparatus can be described by parameters of the low frequency output. For example, most (greater than 50%, greater than 60%, greater than 70%, greater than 80%, greater than 90%, greater than 95%, greater than 99%) of the output of vibration transduction component can be below 250 Hz, below 200 Hz, below 150

Hz, below 125 Hz, or below 100 Hz, such as in the range of about 20 Hz to about 200 Hz, or about 20 Hz to about 100 Hz.

[0064] In some embodiments the vibration transduction component can produce infrasonic waves (i.e., acoustic waves having a frequency below 20 Hz, versus “sonic” having a frequency of 20 to about 20,000 Hz). Devices such as tactile transducers and specialized transducers referred to as linear actuators can produce infrasonic waves. The vibration transduction component capable of producing infrasonic waves can include an electromagnetic motor, with a new magnet structure with a vented center pole to allow air to move in and out more efficiently.

[0065] An exemplary electromechanical transducer which can be used in association with the audio output apparatus of the current disclosure is described in EP2779696A1, which is incorporated herein by reference. In one aspect, the apparatus has a housing that has electromechanical transducer that transduces an electric signal into mechanical vibration, the transducer including a structural unit with at least the following integrated components: at least one pair of magnets, a yoke conducting a magnetic flux generated by the magnets, and a coil supplied with the electric signal. The transducer also includes an armature having an inner portion passing through an internal space of the structural unit and first and second outer portions protruding on both sides from the inner portion. The armature constitutes a magnetic circuit with the structural unit via two regions through which components of the magnetic flux flow in directions opposite to each other in the inner portion. The transducer also includes a first elastic member connecting between the first outer portion of the armature and the structural unit; and a second elastic member connecting between the second outer portion of the armature and the structural unit.

[0066] In some embodiments, the vibration transduction component provides both infrasonic and sonic frequencies. For example, most vibration transduction component can produce predominantly (greater than 50%, greater than 60%, etc.) infrasonic frequencies and sonic frequencies of below 100 Hz.

[0067] The vibration transduction component can be partially or fully enclosed within a housing. Generally, the housing is configured to be placed on the back of the neck, over the uppermost portion of the spine. In particular the housing can be configured for placement below the occipital ridge of the skull, over the cerebellum, where the spinal cord meets the brain. In position, the housing will be proximal to cervical vertebra 1-3.

[0068] Reference is made to FIG. 24 illustrating relevant anatomical features of the upper body including skull 400, occipital ridge 402, cervical spine 1-3 404, spine 408, and central nervous system 410. In modes of practice, the target area for placement of the device with the vibration transduction component is represented by circle 401, where the device is placed. FIG. 25 provide illustrations of portions of the head, showing the cerebellum 412, the location where the skull curves down to the spine 414, and line 416 representing the transverse plane for device placement, which allows easy access to audible, tactile, and olfactory receptors.

[0069] The advantage of placing vibration speakers or similar delivery transducers on the back of the neck is the direct stimulation into the brain since they are engineered to deliver lower audio and vibration frequencies. This also

allows the ear speakers to be optimized to play higher frequencies. An additional benefit of this placement for audio information and sound delivery is for the hearing impaired population that can feel vibration but may not be able to hear clearly. Other uses include assistance in training, post-operative recovery or rehabilitation. Still another use may be situations such as movie theatres, concerts, or similar settings where surround sound output performance may be delivered individually and personally through worn headsets.

[0070] In some cases, the housing can be described in terms of height, width, and thickness ranges. In many configurations, the housing can have a width and height that is greater than its thickness, which can provide the housing with an overall “flat” shape. When in position the height dimension can be defined by upper and lower portions, or edges, which is towards that top of the user’s head and towards the user’s back, respectively. The width dimension can be defined by left and right portions or edges. The thickness can be defined by a body-facing surface, which is configured to be placed against the skin of a user’s neck, and an outer surface, facing away from the neck.

[0071] One or more surfaces of the housing can have curvature. For example, the inner surface of the housing can include one or more curved surfaces. The curved surface can include one or more convex and concave shape(s) providing one or more bulges or one or more indentations on the body facing on the surface. FIG. 10 is a top view of an exemplary housing 100 construction, with outward facing surface 102, and body facing surface 104 (an area of the neck 106 is also shown). The indentations 108 and 110 and bulge 112 can match the contour of the neck.

[0072] In exemplary embodiments, the housing has a height in the range of about 6.5 cm to about 3.5 cm, or about 5.5 cm to about 4.5 cm; a width in the range of about 10 cm to about 5 cm, or about 8.5 cm to about 6.5 cm; and a thickness in the range of about 2 cm to about 0.5 cm, or about 1.5 cm to about 1 cm. As viewed from the outer face or surface, the housing can have a square, rectangular, oval, or circular shape.

[0073] An exemplary weight for the housing, including the vibration component therein, is in the range of about 30 to about 55 grams, or about 35 to 45 grams. Exemplary housing materials include plastics and metals and combinations thereof

[0074] FIG. 11 shows a cross sectional side view of an exemplary housing 120 construction, with outward-facing surface 122, and body-facing surface 124. The outward-facing surface 122 can be curved outwards from the top 23 to the bottom 125 of the housing. A vibration component 126, such as a speaker cone or transduction member, can be secured within the housing. The vibration component can be adjacent to an open area in the housing (e.g., space 127) in which acoustic waves can be generated. The acoustic waves, in turn, are absorbed by the body-facing surface of the housing, which can have a rigid or flexible construction, and cause the vibration of this portion of the housing. The housing can also include one or more areas (e.g., 128, 129) for placement of components useful for operation of the vibration component, such as a battery, a splitter, a short range wireless receiver (e.g., Bluetooth) device, a micro-processor board, and a sensor. Areas for the placement of

these features can be located between the outwards-facing surface and the vibration component or open area in the housing.

[0075] In embodiments of the disclosure, the attachment member is configured to allow for removable attachment of the apparatus to the ears or to speaker enclosures of a speaker set that is placed about the ears. In embodiments of the disclosure, the attachment member is formed of a cord, a strip of material, a band of material, a mesh, etc. The attachment member can have one or more of the following properties: flexibility, stretchability, elasticity, compliance, durability, and strength. Preferably, the attachment member is flexible, stretchable, or both flexible and stretchable. In this regard, the attachment member can be described as “non-rigid” or made from a “non-hardened material.” Use of a flexible and/or stretchable attachment member such as an elastic cord attachment member can provide advantages during use. For example, unlike a hardened plastic material, a flexible and stretchable attachment member can provide better isolation of the low frequency vibrations from the vibration component to the back of the neck. Unlike a hardened material, the flexible and/or stretchable attachment member poorly conducts the vibration from the housing, and therefore provides better response at the point of contact, and prevents low frequency vibrational “bleed through” to the speakers around or in the ears.

[0076] The attachment member that is flexible and stretchable can include one or more elastomers. An elastomer is a material that can exhibit a rapid and large reversible strain in response to a stress. Exemplary elastomers include natural rubber (cis-1,4-isoprene polymer), styrene-butadiene rubber, butyl rubber, ethylene propylene diene monomer (EPDM) rubber, polychloroprene, polysulfide, polyurethane elastomers, acrylonitrile butadiene rubber, and silicone rubber.

[0077] The attachment member that is flexible and stretchable can optionally be described in terms of its “stretchability.” For smaller and moderate forces applied to a stretchable material such as an elastomeric cord, a spring constant of a cord can be expressed. A spring constant (k), as measured in N/m, can be calculated by the force applied to the cord over the change in length of the cord.

[0078] If the attachment member is in the form of a cord, the cord can have a certain cross-sectional shape, such as a circular shape. However, the cord may also have an oval or polygonal shape (e.g., square, rectangular, etc.) The size of the cord can be expressed as its cross sectional area, which in some embodiments can be in the range of about 1 mm² to about 120 mm², or about 7 mm² to about 40 mm². For example, an exemplary cord has a diameter in the range of about 3 mm to about 8 mm.

[0079] The attachment member, such as an elastomeric cord, can have an inner elastic material and a fabric outer layer coated around an outer periphery of the elastic inner tube. The fabric outer layer can provide improved comfort for a user.

[0080] The housing can also include one or more features that facilitate attachment of the right and left attachment members to the housing. For example, the housing can include one or more apertures or channels through which the attachment member can pass. The attachment member, such as a cord, can be movable through the aperture or channel. Generally the size of the aperture or channel will be at least as large as the largest cross sectional dimension of the attachment member, such as a cord. Using this arrangement,

the attachment member such as a flexible cord, can be moved through the aperture to adjust the length of the attachment member that is to be looped around the ears or around a speaker enclosure of headphones. In this regard, the apparatus can include a tensioning member that allows the attachment member to be secured in relation to the housing, so that a desired length of cord can extend from the housing for attachment to the ears or a speaker enclosure of headphones. The tensioning member can be one that is integrated in or attached to the housing, such as a clip or a clamp. Alternatively, the tensioning member can be independent from the housing, such as one that is movable over the cord. For example, the tensioning member can be a small clamp having an opening through which the cord can move, which can be immobilized on the cord in a clamped state, and which can contact the housing to provide a stop to the movement of the cord.

[0081] In some embodiments the housing includes two or more apertures through which the attachment members can be moved through. The housing can include additional apertures, such as a total of 3, 4, 5, 6, etc. according to the design of the apparatus. In some embodiments, the apertures can be located at the periphery of the housing. For example, the housing can have a rectangular or oval shape (e.g., the housing having a width that is greater than its height), where at least one aperture is located on each side of the housing. If each side of the housing has two apertures (for a total of four apertures) the apertures may be referred to as upper and lower apertures.

[0082] As an example, FIG. 12A shows a view of the outward-facing surface 142, with upper 145, lower 146, left 148, and right 149 sides, defining upper right, upper left, lower right, and lower left corners of the housing. In each corner there is an aperture, for a total of four apertures (147a, 147b, 147c, and 147d). As shown in FIG. 12B, which is a top cross sectional view of the housing, each aperture (top apertures 147a and 147b are shown) extends from the outward-facing surface 142 to the body-facing surface 144. From the outward-facing surface 142 to the body-facing surface 144 the apertures can be about 2 cm to about 0.5 cm, or about 1.5 cm to about 1 cm.

[0083] There are various ways to connect an attachment member to the housing having apertures as shown in FIGS. 12A and 12B. For example, an attachment member that is a cord can enter aperture 147b from the outward-facing surface 142, continue along the body-facing surface 144 parallel to right side 149 and then exit through aperture 147d. The length of cord that extends away from apertures 147b and 147d can form a continuous loop from the right side of the housing and along the right side of the head, where the proximal end of the loop can attach to the ear or to a speaker enclosure of a headphone. A corresponding arrangement can be provided on the left side of the housing.

[0084] In other modes of attaching, the cord may also enter aperture 147b from the outward-facing surface 142, continue along the body-facing surface 144 parallel to top side 145 and then exit through aperture 147a. The length of cord that extends away from aperture 147a can extend distally to form a continuous loop from the left side of the housing and along the left side of the head, and then return in to aperture 147c from the outward-facing surface 142, continue along the body-facing surface 144 parallel to bottom side 146 and then exit through aperture 147a. The length of cord that extends away from aperture 147d can

extend distally to form a continuous loop from the right side of the housing and along the right side of the head, and then return in to aperture 147d.

[0085] In other modes of attaching, the cord may enter any aperture from the body-facing surface 144 and then continue along the outward-facing surface 142, parallel to either the top or bottom (145, 146) or left or right (148, 149) sides. In some embodiments the housing includes at least one channel (e.g., tunnel) through which the cord is movable wherein the at least one channel is integrated in the housing. For example, the housing can include one or more channels along any part of the periphery of the housing. Alternatively, one or more channels can be present across all or a portion of the outer surface of the housing, across all or a portion of the inner surface of the housing, or through the central portion of the housing. The channel can have entry and exit points for the cord, and therefore can be of a predetermined length, such about 0.5 cm or greater, or 1 cm or greater. The length of a channel can be as great as the entire periphery of the housing, or the length of the upper or lower portions of the housing.

[0086] The housing can include, or be associated with one or more attachment member tensioning feature(s) such as illustrated in FIGS. 13A-15B. The tensioning features can provide a mechanism for adjustment (lengthening or shortening) of the attachment member such as a cord so the user can achieve a desired tension between the housing and the ears or the speaker enclosures of headphones.

[0087] As an example, FIG. 13A shows a view of a housing with outward-facing surface 152, with upper 155, lower 156, left 158, and right 159 sides. Within the housing are two channels (161 and 162, shown as dashed lines) sized to accommodate the attachment member (e.g., cord). Channel 161 can have an entry/exit point 157a on the left side 158 of the housing, near the upper side 155; likewise, channel 162 can have an entry/exit point 157b on the right side 159 of the housing, near the upper side 155. Channels 161 and 162 extend from 157a and 157b towards lower side 156, and towards the middle of the housing, and have an exit points 157c and 157d, respectively. Ends of the cord (167 and 168) are shown extending out of channels 161 and 162 from the bottom side 156. The cord can continue out of channels 161 and 162 (via entry/exit points 157c and 157d) and form loops from the left and right sides of the housing, and along the left and right sides of the head respectively, and then return to points 164 and 165 on the left 158 and right 159 sides of the housing, near the lower side 156, where the cord may be fixed to the housing. The length of the loops may be adjusted by feeding a length of cord through the channels. Further, the cord can be secured using a depressible clamping member 151, which can include openings for each cord and which can clamp the cord in place using a spring mechanism. FIG. 13B shows a view of a housing from the lower side, with outward-facing surface 152 and body-facing surface 154.

[0088] In some embodiments, the housing includes one movable member(s), such as a member that is rotatable in place, or movable in relation to the housing, which allows the extension and/or retraction of a length of cord from the housing. As an example, FIG. 14a shows a view of a housing with outward-facing surface 172, with upper 175, lower 176, left 178, and right 179 sides. Within the housing is an upper space that allows passage of the cord from an entry/exit point 177a on the left side 178 of the housing, near the upper

side 175, to an entry/exit point 177b on the right side 178 of the housing, near the upper side 175. The housing also includes a movable member 171, such as a disc or dial that is rotatably immobilized by a portion of the housing. A portion of the movable member 171 can protrude from the upper side 175 of the housing 172, so that it can be manipulated by a user. Within the housing, the movable member 171 can contact a portion of the cord, for example, the rotatable member can be attached to the cord. Upon rotation of the movable member 171, the cord is pulled further into the housing, causing shortening of its length, and therefore shortening of the length of the loop from the either or both side(s) of the housing. The movable member 171 can also be rotated in the opposite direction so length of the cord is released from the housing, causing lengthening of the loop from the either or both side(s) of the housing. The lower portion of the housing can have a mirror arrangement of features, including entry/exit points 177c and 177d and movable member 173, which function to shorten and lengthen the cord in the same manner. FIG. 14B shows a view of the housing from the upper surface showing movable member 171.

[0089] Alternatively, the movable member 171 can be pushed towards the center of the housing to cause shortening of the attachment member such as a cord. For example, movable member 171 is in contact with attachment member at point 181 within the housing, and movement of the member 171 towards the center of the housing draws length of the cord within the housing to shorten its overall length outside of the housing. Member 171 can be movable within a slot formed in the housing. The lower portion of the housing can have a mirror arrangement of features, including entry/exit points 177c and 177d and movable member 173, which function to shorten and lengthen the cord in the same manner.

[0090] As another example of a tensioning member, FIG. 15A shows a view of a housing with outward-facing surface 192, with upper 195, lower 196, left 198, and right 199 sides. Within the housing is an upper space that allows passage of the cord from an entry/exit point 197a on the left side 198 of the housing to an entry/exit point 197b on the right side 198 of the housing. Also within the housing is a lower space that allows passage of the cord from an entry/exit point 197c on the left side 198 of the housing to an entry/exit point 197d on the right side 198 of the housing. The housing also includes a rotatable member 191, such as a disc or dial that is rotatably immobilized by a portion of the housing, near the center of the housing. Within the housing, the cords can be attached to the rotatable member 191 and can contact a portion of the cord. Upon rotation of the rotatable member 191, the cord is pulled further into the housing, causing shortening of its length, and therefore shortening of the length of the loop from the either or both side(s) of the housing. The rotatable member 191 can also be rotated in the opposite direction so length of the cord is released from the housing, causing lengthening of the loop from the either or both side(s) of the housing. The lower portion of the housing can have a mirror arrangement of features, including entry/exit points 177c and 177d and rotatable member 173, which function to shorten and lengthen the cord in the same manner. Alternatively, length of the cord can be adjusted using two entry/exit points instead of four. For example, the

length of the cord can be adjusted through any two entry points on the left 198, right 199, upper 195, or lower 196 sides.

[0091] In other embodiments, the attachment apparatus includes a tensioning member that is attachable to the speaker enclosure or band of a headphone set. For example, as another example of a tensioning member, FIGS. 19A-19B illustrate a housing 240 which can be positioned on the back of the neck of a user, over the uppermost portion of the spine, and two cord loops (242a-c, 244a-c) and extending from the sides of the housing towards and around attachment discs (245, 247) which include a tensioning mechanism to cause shortening or lengthening of the cord. The tensioning mechanism can include a dial that is attached to a portion of the cord to draw in or release the cord when the dial is turned in a clockwise or counterclockwise direction, respectively. The attachment discs (245, 247) can be attached to the outer surface of the headphone band 249 or speaker enclosures (241, 243) through an adhesive or an attachment mechanism, such as a suction cup. Reference is made to FIG. 18C, illustrating use of an adhesive to attach an attachment disc with tensioning mechanism.

[0092] The housing can also include a port for an electrical connection, or electrical connections (e.g., wire) leading from the housing, to a charging outlet, headphone, smartphone, or similar peripheral device. The electrical connection can provide power and/or signal to the internal components. In other arrangements the apparatus can include a Bluetooth receiver, such as located within the housing, to provide signal to the low frequency vibration component. In this arrangement, the housing may also include a power source to drive the vibration component along with the signal. The power source could be provided by a disposable battery that is placed within the housing, or a rechargeable battery could be permanently built into the housing.

[0093] The attachment member can be in the form of a cord that is attached directly or indirectly connected to the housing. The portion of the cord that is attached to the housing is referred to as the proximal portion, and the portion of the cord that is configured for removable attachment to the ears or to speaker enclosures of a speaker set that is placed about the ears is referred to as the distal portion. The distal portion of the cord can be in the form of a loop of a size that fits around the front of the ear; for example, the proximal portion of the loop portion is configured to contact a user between the upper helix of the ear and the skull and then down underneath the ear lobe. In this portion of the loop, the cord includes a material which stiffens the cord, or makes it less flexible and more rigid, and conformable to the shape of this portion of the ear. Therefore, the cord may have a flexibility that differs along its length, being more flexible at the proximal portion near the housing, and less flexible at the distal portion.

[0094] FIGS. 16A and 16B are illustrations of an attachment audio delivery device in accordance with one embodiment of the invention. The apparatus has a housing 200 which is positioned on the back of the neck of a user, over the uppermost portion of the spine, and two cord loops extending from the sides of the housing towards the ears (201, 203) of the user. The right loop has right upper portion 202a, right lower portion 202c, and a right loop distal portion 202b configured to go around the top, front, and bottom of the right ear 203. The left loop correspondingly has left upper portion 204a, left lower portion 204c, and a

left loop distal portion **204b** (not shown) configured to go around the top, front, and bottom of the left ear **201**. The distal portion of the loop around the ear (**202b**, **204b**) can be of the same material and construction portions **202a** and **202c**, and **204a** and **204c**, or can be of a different material and/or construction. If of a different material and/or construction, the distal portion of the loop around the ear (**202b**, **204b**) can have one or more of the following properties to facilitate placement around the ear: increased rigidity of the cord, a different texture or material on the outside of the cord, and/or a different shape and/or thickness of the cord.

[0095] Similar to the device shown in FIGS. **16A** and **16B**, the device of **16C** includes housing **360** for the vibration component, with right and left loops (**362a-c**, **364a-c**) configured to go around the ears or speaker enclosures at their distal ends. The device of **16D** includes housing **370** for the vibration component, with right and left loops (**372a-c**, **374a-c**) configured to go around the ears or speaker enclosures at their distal ends, and a material, such as a fabric or plastic between the upper and lower portions of the loops (**372a** and **c**, and **374a** and **c**).

[0096] FIGS. **17A-17C** are illustrations of an attachment audio delivery device in accordance with one embodiment of the invention, attached to a headphone set. The apparatus has a housing **210** which is positioned on the back of the neck of a user, over the uppermost portion of the spine, and two cord loops (**212a-c**, **214a-c**) and extending from the sides of the housing towards and around rigid speaker enclosures (**211**, **213**) of a headphone set. The rigid speaker enclosures (**211**, **213**) can be between ear padding for the headphones and a headphone band **219**. The right loop has right upper portion **212a**, right lower portion **212c**, which do not contact the speaker enclosure of the headset. The right loop also has portion **212b**, which is configured to contact the speaker enclosure on its upper, forward, and bottom portions. The distal portion of the loops (**212b**, **214b**) around the rigid speaker enclosures can have one or more of the following properties to facilitate its placement around the enclosures: increased rigidity of the cord, a different texture or material on the outside of the cord, and/or a different shape and/or thickness of the cord.

[0097] Similar to the device of FIGS. **17A-17C**, the device of FIG. **17D** includes housing **380** for the vibration component, with right and left loops (**382a-c**, **384a-c**) configured to go around speaker enclosures (**383**, **385**) at their distal ends, and a material, such as a fabric or plastic between the upper and lower portions of the loops (**382a** and **c**, and **384a** and **c**).

[0098] FIGS. **18A-18C** are illustrations of an attachment audio delivery device in accordance with another embodiment of the invention, attached to a headphone set. The apparatus has a housing **210** which is positioned on the back of the neck of a user, over the uppermost portion of the spine, and two cord loops (**222a-c**, **224a-c**) and extending from the sides of the housing towards and around attachment discs (**225**, **227**). The attachment discs (**225**, **227**) are attached to the outer surface of the speaker enclosures (**221**, **223**) through an adhesive or an attachment mechanism, such as a suction cup. For example, with reference to FIG. **18C**, the attachment disc **227** can have a speaker-facing face **235** with an adhesive that can contact the outward-facing face of the speaker enclosure **223**. An adhesive lining can be peeled away to expose the adhesive so a user can apply the disc **227** to a speaker enclosure. The disc **227** can also include a

groove **231** around all or part of the circumference of the disc, defined by two ridges (**234**, **232**). The attachment member can be looped around disc **227** and held within the groove **231**.

[0099] FIGS. **9A** and **9B** illustrate a wearable audio delivery and monitoring device **90** that is placed around the back of neck, and not over the ears, and contains one or more speakers, physiological sensors and/or therapeutic delivery components **96**. Output information may be transmitted to a user's computer or smartphone so the user can utilize the information to increase performance. In related embodiments, due to the close proximity or contact with the user's skin, the devices taught herein include sensors that detect body temperature, humidity levels, chemical levels emitted by the body and detectable at skin level and other physiological functions that are detectable noninvasively and can be used to assess the health of the user.

[0100] In yet other embodiments, the disclosure provides an integrated audio delivery apparatus. The term "integrated" refers to arrangements where the housing including the vibration transduction component configured for placement at the back on the neck is non-removably attached to speaker components configured for use in or about the ear, such as headphones and earbuds. In some embodiments, the integrated audio delivery apparatus includes a housing including a vibration speaker or vibration transduction component configured to be placed on the back of the neck and over the spine, right and left ear bud or headphone speaker enclosures for the ear, and right and left attachment members connecting the housing to the right and left ear bud or headphone speaker enclosures.

[0101] In one embodiment of an integrated apparatus is illustrated in FIGS. **1A** and **1B**. FIGS. **1A** and **1B** illustrate a wearable audio delivery and/or monitoring device **10**, such as over-the-ear headphones, that incorporate vibration speakers or similar transduction members, as well as physiological sensors **16**. The device is designed to be placed on the back of the neck and extends to the ears. This wearable device can be connected to an output device by a cable, wire, or wireless methods. Other items such as a control board, audio file, amplifier, equalizer, battery, wireless or similar components **12** can be incorporated into the device, and can include controls **22** for power, volume selection, LED, and charger. The over-the-ear speakers **14a** and **14b** can be similar to existing commercially available over-the-ear devices, and delivery methods. Arms (**13a**, **13b**) can extend between the speakers (**14a**, **14b**) and a housing **31**

[0102] The clamp and compression attachment method of FIGS. **1A** and **1B** can be similar to behind the neck earmuffs that include a tension member capable of rolling up when not in use and providing tension against the head when in use. This allows for the device to be held in place on the back of the neck, and does not require an over the top head-band component.

[0103] In related embodiments, the devices illustrated in FIGS. **1C** and **1D** can also include portions that similar to behind the neck earmuffs that include a tension member. For example in FIG. **1C** the apparatus includes a vibration speaker **326** and arms (**323a**, **323b**) that extend over the ears, but that do not necessarily include in-ear or over-the-ear speakers. In FIG. **1D** the apparatus includes a vibration speaker **336** and arms (**333a**, **333b**) that extend over the ears attached to over the ear speakers (**334a**, **334b**).

[0104] In further detail, FIG. 2 illustrates a wearable audio delivery and/or monitoring device 20 with features and functionalities similar to the device of FIG. 1. In this embodiment, the wearable audio delivery and/or monitoring device 20 includes an over the head member 28 to help keep the device in place. The device 20 can also include vibration speakers or similar transduction members, or physiological sensors 26; a control board, audio file, amplifier, equalizer, battery, wireless or similar components 22; controls 22 for power, volume selection, LED, and charger; and over-the-ear speakers 24a and 24b.

[0105] Referring now to FIG. 3, shown is an integrated wearable audio delivery and/or monitoring device 30 that incorporates vibration speakers 36 or similar transduction members, and/or monitoring sensors, into headphones that go around the back of the head and to the ears, is described. The device 30 can include attachment arms (33a, 33b) between the earphones (33a, 33b) and a housing 31 around the vibration speakers 36 or similar transduction members, and/or monitoring sensors. In an example embodiment, the control board 32 and other components can be placed in a separate housing and connected to an audio output device 37, thus decreasing the weight and size of the wearable audio delivery and monitoring device 30.

[0106] Referring to FIG. 4, show is a wearable audio delivery and/or monitoring device 40 that incorporates a system of attaching vibration speakers 46 or similar transduction members, and/or sensors configured for placement on the back of the neck, and also including in or over the ear buds (44a, 44b), which can be connected to the audio output through wired or wireless features. The vibration speakers 46 or similar transduction member may be within a device housing 41, which can be attached directly to the collar, hatband or inside a pouch located in the collar with the use of a clip 49 or similar mechanism.

[0107] FIG. 5 shows a wearable audio delivery and monitoring device 50 that incorporates a vibration speaker 56 or similar transduction members, and/or health monitoring sensors, placed on the back of the neck and associated with the back of a helmet or hat 58, such as by attachment tab 57. Ear buds (54a, 54b), can be connected to the audio output through wired or wireless features, and optionally attached to the side of the helmet or hat 58 with attachment tab 53b (attachment tab 53a not shown). The helmet or hat 58 may be worn during activities requiring a helmet such as skiing, snowboarding, hockey, or other similar activities.

[0108] Referring now to FIG. 7A, a wearable audio delivery and/or monitoring device 70 includes vibration speakers 76 or similar transduction members located on the back of the neck, is described. The device 70 also includes an over the head member 78 to help keep the device in place, in or over-the-ear speakers 74a and 74b, and attachment arms (73a, 73b) between the earphones and a housing 71 around the vibration speaker 76. In an example embodiment, the wearable audio delivery and monitoring device 70 includes a microphone 77 to communicate with others, such as those used in gaming. In an example embodiment, wearable audio delivery and monitoring device 70 is capable of connecting to a gaming system such as Xbox®, PS3®, games on a smartphone or handheld device, or any other similar device. The audio sensory information and vibrational energy generated by signals from the game may be delivered to the user through wearable audio delivery and monitoring device 70. In an alternative embodiment, users using electronic devices

to practice flying or driving may wear a wearable audio delivery and monitoring device 70. In still another alternative embodiment, users can communicate with professionals such as doctors to receive and deliver diagnoses and therapies.

[0109] Similar to FIG. 7A, of device 340 of FIG. 7B includes a vibration speaker 346 or similar transduction members located on the back of the neck, headband 348 to help keep the device in place, over-the-ear speakers 344a and 344b, and attachment arms (343a, 343b) between the earphones and a housing 71 around the vibration speaker 76.

[0110] FIGS. 8A-8C illustrate a wearable audio delivery and monitoring device 80 that is attached, incorporated into or in conjunction with wearing glasses 89, headsets such as for virtual reality experiences or eye covering. This embodiment holds the speakers (84a, 84b) over or near the ears, and allows for vibration speakers, sensors, or similar transduction member 86 to be attached around the back of the head. The device includes sleeves (83a, 83b) in which distal portion of the eyeglass temples (i.e., temple tips) can be placed. The sleeves can be made of an elastomeric material. The wearable glasses 89 may be glasses without corrective lenses, glasses with corrective lenses, or other lenses known in the art. An additional benefit of this embodiment could be used in conjunction with travel masks or eye covers where the vibratory members can enhance relaxation, relieve anxiety and calmness. FIG. 8C illustrates a device having transduction member 356, input cord 357, and sleeves (353a, 353b), which is not attached to eyeglasses.

[0111] Another embodiment of an integrated apparatus is illustrated in FIGS. 20A-20B. The integrated apparatus has a housing 250 which is configured to be positioned on the back of the neck of a user, over the uppermost portion of the spine, and two cord loops (252a-c, 254a-c) extending from the sides of the housing towards the ears of the user. The right loop has right upper portion 252a, right lower portion 252c, and a right loop distal portion 252b attached or associated with an ear bud 256, which is configured to be placed within the users right ear. A corresponding arrangement is on the left side of the apparatus (left with left upper portion 252a, left lower portion 252c, etc.). Within the housing is an upper space that allows passage of the cord from an entry/exit point 257a on the left side of the housing to an entry/exit point 257b on the right side of the housing. The lower portion of the housing can have a mirror arrangement of features, including entry/exit points 257c and 257d, or the cord can be affixed at these corners. The housing 250 can also include a rotatable member 251, such as a disc or dial that is rotatably immobilized by a portion of the housing, near the center of the housing, which, upon its rotation, can cause the cord to be pulled into the housing, or released from the housing when turned the other way. The length of the cord can be adjusted using two entry/exit points or four entry/exit points.

[0112] Similar to the device of FIG. 20A, the device of FIG. 23 includes a housing 390 with vibration speaker or similar transduction members configured to be located on the back of the neck, and two cord loops (392a-c, 394a-c) extending from the sides of the housing towards the ears of the user, and ear buds (396, 398).

[0113] The earbuds as shown in the integrated apparatus of FIGS. 20A-20B can receive signal via wired or wireless components. If a wire is used to provide signal, the wire (not shown in FIGS. 20A-20C) can run along the length of the

upper portion (e.g., 252a) or lower portion (e.g., 252c) of the loop of cord, towards and into the housing 250. Using a loop of cord that is flexible and stretchable, the extra length of wire can be bunched and attached to the cord at intervals along the cords length to accommodate for the stretching of the cord when it is pulled towards the ears.

[0114] If a wireless component (e.g., Bluetooth) is used to provide signal, the receiver can be located as a part of the earbud assembly 256. The earbud assembly can also include a small battery, which can be disposable or rechargeable. If the battery is rechargeable, the housing 251 can include one or more induction components (261, 263) so the batteries of the ear buds can be charged when not in use. For example, with reference to FIG. 20B, the cord loops (252a-c, 254a-c), can be retracted into the housing 250 and the earbuds (256, 258) can be placed proximal to the induction components (261, 263) to charge the batteries in the earbud assemblies.

[0115] In some embodiments, an earbud member comprises features as illustrated in FIG. 21. Earbud assembly 276 includes a central portion 273 that is positioned over the ear canal and that houses an earbud speaker, and optionally battery and receiver (Bluetooth) components. Upper central portion 275 can have a shape that conforms to a portion of the concha. The earbud assembly 276 also includes a channel portion configured to accommodate a portion of the attachment member, such as a cord. For example, the channel portion can be in the form of a curved tube having a first upper portion 281 that is configured to be placed between the upper helix 288 of the ear and the head, a second upper portion 283, configured to curve downward toward the tragus of the ear, a middle portion 285 that is connected to the central portion 273 of the earbud member and configured to reside over the tragus of the ear, and a lower portion configured to be adjacent to the earlobe 286. The earbud assembly also has an upper opening 278 in which the upper portion 272a of the loop of cord enters/exits, and a lower opening 279 which the upper portion 272c of the loop of cord enters/exits.

[0116] The earbud member 276 can be made from a semi-flexible semi-rigid material, such as poly(ethylene), poly(vinyl chloride) (PVC), and poly(urethane).

[0117] Another embodiment of an integrated apparatus is illustrated in FIGS. 22A-22D. The integrated apparatus has a housing 300 which is configured to be positioned on the back of the neck of a user, over the uppermost portion of the spine. Two cord loops (302a-c, 304a-c) extend from the sides of the housing and attach to rotatable members (305, 307), such as discs or dials, are associated with the outer surface of the headphone band 309. (Alternatively, the rotatable members (305, 307) are associated with the outer surface of the speaker enclosures (301, 303)). The right loop has right upper portion 302a, right lower portion 302c, and a right loop distal portion 302b affixed to rotatable members 305. A corresponding arrangement is on the left side of the apparatus (left with left upper portion 302a, left lower portion 302c, etc.).

[0118] Referring to FIGS. 22A and 22B, in use, the user can place the housing 300 on the back of the neck and the speaker enclosures (301, 303) with soft pads (311, 313) about the ears. For example, the housing 300 with two cord loops (302a-c, 304a-c) can be at an angle in the range of about 80° to about 140°, or about 95° to about 125° to the headphone band 309.

[0119] Referring to FIGS. 22C and 22D, when the vibration transduction component in the housing is not in use the user can rotate the rotatable members (305, 307) so the two cord loops (302a-c, 304a-c) are swung upwards and aligned with the headphone band 309, and so to place the housing on the outside surface of the headphone band 309. If needed, the cord loops (302a-c, 304a-c) can be loosened or tightened at the housing to provide a desired tension at the back of the neck in use, and over the top of the headphone band 309 during storage.

[0120] The various embodiments described herein improve upon existing audio and video content delivery headsets such as headphones, virtual reality, augmented reality or other such headsets that are used when playing games, listening to music or watching videos. By including a vibratory content delivery method that is held in place on the spine, the user's mobile audio experience is enhanced. Additionally, by including a place and method to release olfactory stimulation over or near the nose, we help to create a multi-sensory experience to consumers wherever they are.

[0121] In a related embodiment, it is also taught herein that various forms of content, such as audio, video, vibratory, and olfactory sensory stimulation, can be created and delivered through the described embodiments to teach, improve, entertain and heal an individual. As an example, an included embodiment illustrates where a medical professional could record and deliver multi-sensory content to help a patient with a specific condition. As another example, a parent could use recorded multi-sensory content to help their child with conditions.

[0122] Referring now to FIGS. 26-36, FIG. 26 illustrates a mobile content delivery headset such as a virtual or augmented reality headset that delivers recorded content that can be seen, heard, felt and smelled. The headset receives recorded content and delivers video through a face or eyepiece or viewing display 600. Auditory content is delivered through various types of speakers or transducers that are attached or integrated into the headset system and worn over, on or near ears 601, as well as through a tactile transducer that is placed over a spine 602. It is envisioned that other auditory delivery methods such as bone conduction could be incorporated into the headset as well. An over-the-head strap 603 that holds the eyepiece 600 in place is shown. Additionally, it is envisioned that olfactory receptacles could be included in the eyepiece or system and when activated, could release smells in conjunction with the content over or near a user's nose.

[0123] Referring now to FIG. 27, and similar to FIG. 26, there is illustrated an example embodiment of a mobile content delivery headset such as a virtual, mixed or augmented reality headset with included visual 600, auditory 601 and tactile 602 sensory stimulation components.

[0124] FIG. 28 illustrates an example embodiment of an adjustable connection assembly or system 604 for attaching a tactile transducer component 605 to an adjustable audio delivery arm 606 of a mobile content delivery headset. The adjustable audio delivery arm could have similar features as over the head headphones, and could be made from such materials as plastic, rubber or similar stretchable materials. The adjustable connection assembly could be made from adjustable and pliable materials such as elastic or similar. This embodiment allows the transducer to be held in place on the back of the neck and top of the spine. Additionally, it allows the transducer to move freely and deliver tactile

vibrations to the user. Also shown are manual controls, such as for volume, for both the transducer component 607 and the speaker on the ears 608. This manual adjustability of each component allows the user to customize the user's audio experience.

[0125] Referring now to FIG. 29, this figure illustrates a side view of a mobile content delivery system with a different shape. Rather than attaching the audio arm and earpieces 610, an in-ear earphone set 613 is provided adjacent the user's ears and to the side of the video eyepiece 611. This description illustrates how the earpieces can attach to the top of the eyepiece that hangs from the forehead and over the eyes. The benefit of this product feature allows the tactile transducer component 612 to be held in place on a user's spine without bending the audio arms.

[0126] FIG. 30 illustrates a mobile content delivery system that is a fully integrated system with video 615, audio 616 and tactile 617 delivery components. Construction materials are envisioned to be similar to other types of wearable electronics products. The benefit of this system is the lightweight, all-inclusive, comfortable design that molds to the user's head. Additionally, the arms have a conforming bended shape behind the ears 618 to allow the tactile transducer to be held in place on the spine.

[0127] Referring now to FIG. 31, there is illustrated a mobile content delivery system with similar features as FIG. 30. The primary difference between the two is the use of in-ear speakers 620 compared to other designs that show over or even on ear speakers.

[0128] FIG. 32 illustrates a mobile content delivery system that incorporates an over-the-head band 625, similar to over the head headphones. The benefit over other described embodiments is the ability to shorten the over-the-head eyepiece attachment 626 so it does not go all the way to the back of a user's head. This is especially beneficial for users with longer hair.

[0129] Referring now to FIG. 33, there is illustrated a mobile content delivery headset with an over-the-head attachment system 630 that holds an eyepiece 631 and tactile component 632 securely in place. Audio delivery arms 633 such as over, on or in-ear speakers are attached to and extend from the eyepiece.

[0130] FIG. 34 illustrates a mobile content delivery headset similar to other embodiments with the improvement being an adjustable feature 635 that allows components such as the tactile transducer 636 to move independently but fit snugly. Additional features include accordion or spring designs, stretchable materials such as elastic, sliding rails, and the like.

[0131] Referring now to FIG. 35, there is illustrated a mobile content delivery headset, similar to FIG. 29, but without the eyepiece. The shape is similar to a headband or hairband and circumferential around the user's head to hold the audio delivery speakers 640 and tactile transducer 641 in place.

[0132] FIG. 36 illustrates a mobile content delivery headset with speakers or similar transduction components placed inside the materials and worn directly over, on or near the user's ears 645. This feature is beneficial in that it simplifies the construction of the headset.

[0133] The following patents and publications are incorporated herein by reference in their entireties: U.S. Publication No. 2012/0253236 A1 and International Publication No. WO 2013/122870 A1.

[0134] The foregoing specific embodiments of the present invention as set forth in the specification herein are for illustrative purposes only. Various deviations and modifications may be made within the spirit and scope of the invention without departing from the main theme thereof.

What is claimed is:

1. A wearable audio and vibrational delivery apparatus configured for use with a speaker set that is placed in or about the ears, the apparatus comprising (a) a housing comprising at least one vibration speaker or vibration transduction component, the housing configured to be positioned on the back of the neck and on the spine, and (b) right and left attachment members with a proximal portion directly or indirectly connected to the housing, and the attachment members each having a distal portion configured for removable attachment to the ears or to speaker enclosures of a speaker set that is placed about the ears.

2. The apparatus of claim 1 wherein the right and left attachment members are formed of one or more non-hardened material(s).

3. The apparatus of claim 1 wherein the right and left attachment members are flexible and stretchable.

4. The apparatus of claim 2 wherein the right and left attachment members are flexible and stretchable

5. The apparatus of claim 1 wherein each attachment member comprises a loop portion.

6. The apparatus of claim 1 wherein the distal portion of the loop portion is configured to either (i) contact a user between the upper helix of the ear and the skull or (ii) a proximal portion of a speaker housing that is placed about the ears.

7. The apparatus of claim 1 wherein the attachment member comprises an inner elastic material and an outer fabric material.

8. The apparatus of claim 1 wherein the housing has one or more openings or channels in which the attachment member moves through.

9. A method for attaching a wearable audio and vibrational delivery output apparatus configured for use with a speaker set that is placed in or about the ears comprising steps of (a) providing an apparatus comprising (i) at least one vibration speaker or vibration transduction component that is configured to be positioned on the back of the neck and on the spine, and (i) right and left attachment members directly or indirectly connected to the at least one vibration speaker or vibration transduction component, and (b) attaching a proximal portion of each attachment member to the ears or to speaker housings of a speaker set that is placed about the ears.

10. A wearable audio delivery apparatus comprising (a) a speaker set that is placed in or about the ears, (b) a housing comprising at least one vibration speaker or vibration transduction component, the housing configured to be positioned on the back of the neck and on the spine, and (c) right and left attachment members each comprising a proximal portion directly or indirectly connected to the housing, and a distal portion attached to a portion of a speaker set that is placed in or about the ears, wherein the attachment members are flexible, stretchable, or both flexible and stretchable.

11. A wearable monitoring apparatus comprising (a) a housing comprising a sensor, the housing configured to be positioned on the back of the neck and on the spine, and (b)

right and left attachment members with a proximal portion directly or indirectly connected to the housing, and the attachment members each having a distal portion configured for removable attachment to a headpiece.

* * * * *

专利名称(译)	用于颈后部的感觉刺激或监测装置		
公开(公告)号	US20170135896A1	公开(公告)日	2017-05-18
申请号	US15/269655	申请日	2016-09-19
[标]申请(专利权)人(译)	科帕动物保健公司		
申请(专利权)人(译)	杯动物保健有限公司		
当前申请(专利权)人(译)	杯动物保健有限公司		
[标]发明人	SNOW BUDDY L		
发明人	SNOW, BUDDY L.		
IPC分类号	A61H23/00 A61B5/024 A61B5/026 A63B71/06 A61B5/0476 A61B5/11 A61B5/00 A61N1/36 A61B5/021		
CPC分类号	A61H23/008 A61N1/36014 A61B5/02438 A61B5/026 A61B5/021 A61B5/0476 A61H2205/04 A61B5/6822 A63B71/0622 A63B71/0686 A63B2071/0625 A63B2071/0655 A61H2205/02 A61B5/1118 A61B5/0205 A61B5/024 A61B5/4836 A61H23/0218 A61H23/0236 A61H2201/1604 A61H2201/165 A61H2201/5097 A61H2230/06 A61H2230/10 A61H2230/207 A61N1/0456 A61N1/0484 H04M1/05 H04R5/0335 H04R2205/026 H04R2460/13 A61N1/00 G09B19/00 G09B19/0038 G16H20/30 G05G9/047 A61H23/00 A61H23/02 A61H2201/0157 A61H2201/16 A61H2201/1602 A61H2201/1607 A61H2201/1609 A61H2201/1611		
优先权	61/955384 2014-03-19 US		
其他公开文献	US10695263		
外部链接	Espacenet USPTO		

摘要(译)

这里描述的是可穿戴的感觉刺激和监测装置，其可以沿着颈部的后部佩戴并且与脊柱接触。本文描述的装置刺激一种或多种感觉，包括听觉，触觉或嗅觉。还描述了允许感测和监测诸如心率，血压和运动的生理参数的装置。该装置还具有允许容易地附接或集成到头部上佩戴的物品的特征。

