



US 20160128592A1

(19) **United States**
(12) **Patent Application Publication**
Rosen et al.

(10) **Pub. No.: US 2016/0128592 A1**
(43) **Pub. Date: May 12, 2016**

(54) **LOW FIELD MAGNETIC RESONANCE METHODS AND APPARATUS**

Publication Classification

(71) Applicant: **Hyperfine Research, Inc.**, Guilford, CT (US)

(51) **Int. Cl.**
A61B 5/04 (2006.01)
A61B 5/0488 (2006.01)
G01R 33/36 (2006.01)
A61B 5/0402 (2006.01)
A61B 5/00 (2006.01)
G01R 33/48 (2006.01)
A61B 5/0476 (2006.01)
A61B 5/0496 (2006.01)

(72) Inventors: **Matthew Scot Rosen**, Somerville, MA (US); **Gregory L. Charvat**, Guilford, CT (US); **Laura Sacolick**, Madison, CT (US); **Mathieu Sarracanie**, Somerville, MA (US); **Jonathan M. Rothberg**, Guilford, CT (US); **Tyler S. Ralston**, Clinton, CT (US)

(52) **U.S. Cl.**
CPC *A61B 5/04012* (2013.01); *A61B 5/0476* (2013.01); *A61B 5/0488* (2013.01); *A61B 5/0496* (2013.01); *A61B 5/0402* (2013.01); *A61B 5/7425* (2013.01); *G01R 33/4806* (2013.01); *G01R 33/3614* (2013.01); *A61B 2019/5454* (2013.01); *A61B 2576/00* (2013.01)

(73) Assignee: **Hyperfine Research, Inc.**, Guilford, CT (US)

(21) Appl. No.: **14/938,333**

(57) **ABSTRACT**

(22) Filed: **Nov. 11, 2015**

According to some aspects a system is provided comprising a low-field magnetic resonance (MR) device, at least one electrophysiological device, and at least one controller configured to operate the low-field MR device to obtain MR data and to operate the at least one electrophysiological device to obtain electrophysiological data.

Related U.S. Application Data

(60) Provisional application No. 62/078,383, filed on Nov. 11, 2014.

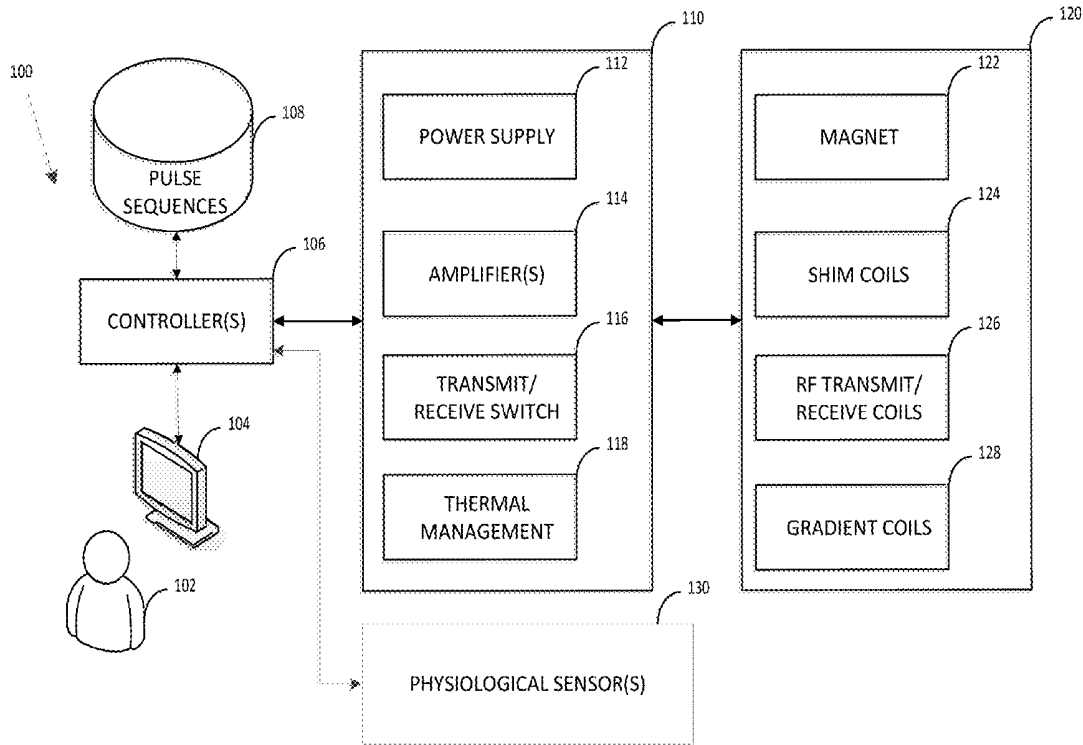

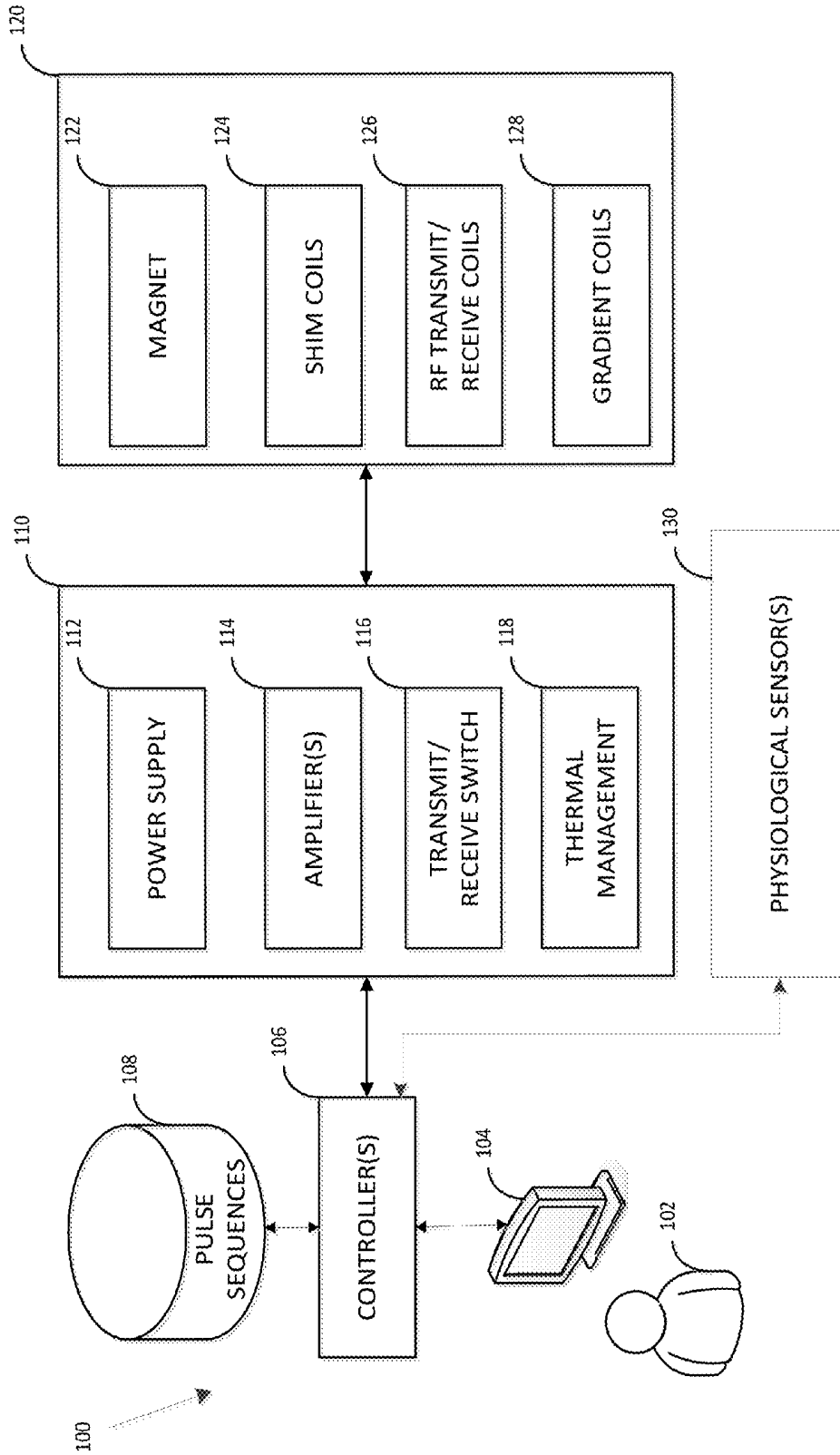

FIG. 1

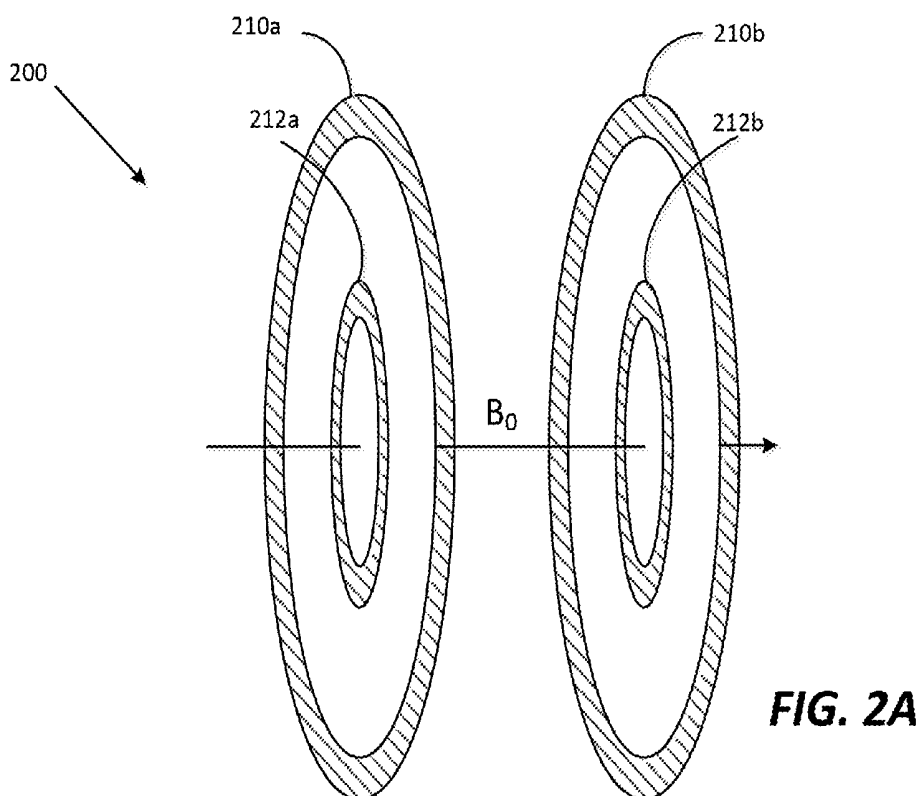

FIG. 2A

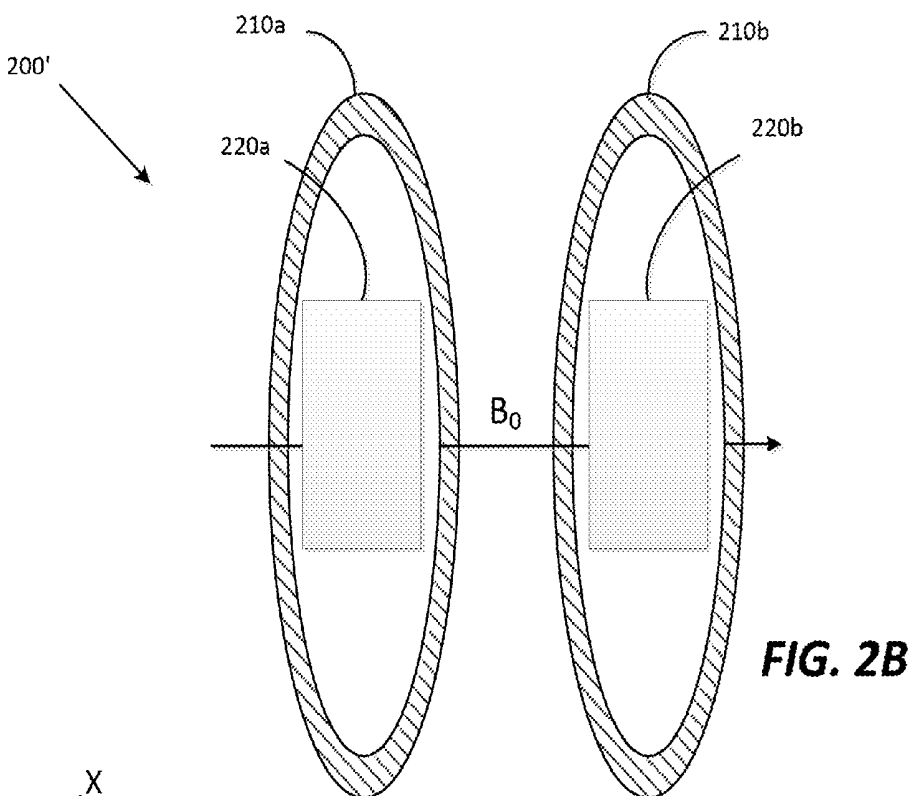
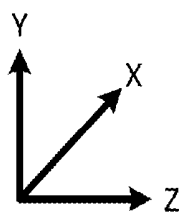

FIG. 2B



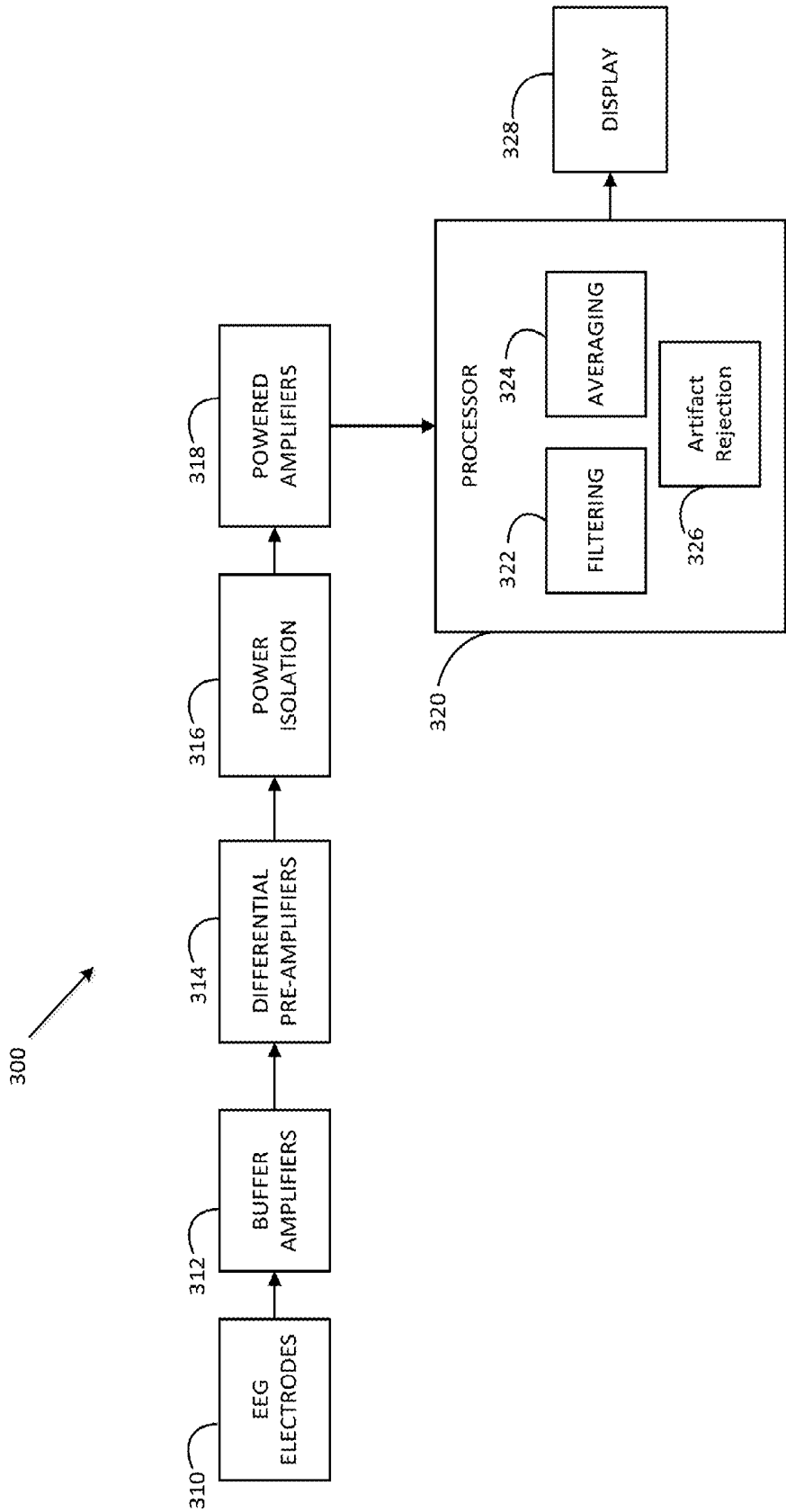

FIG. 3

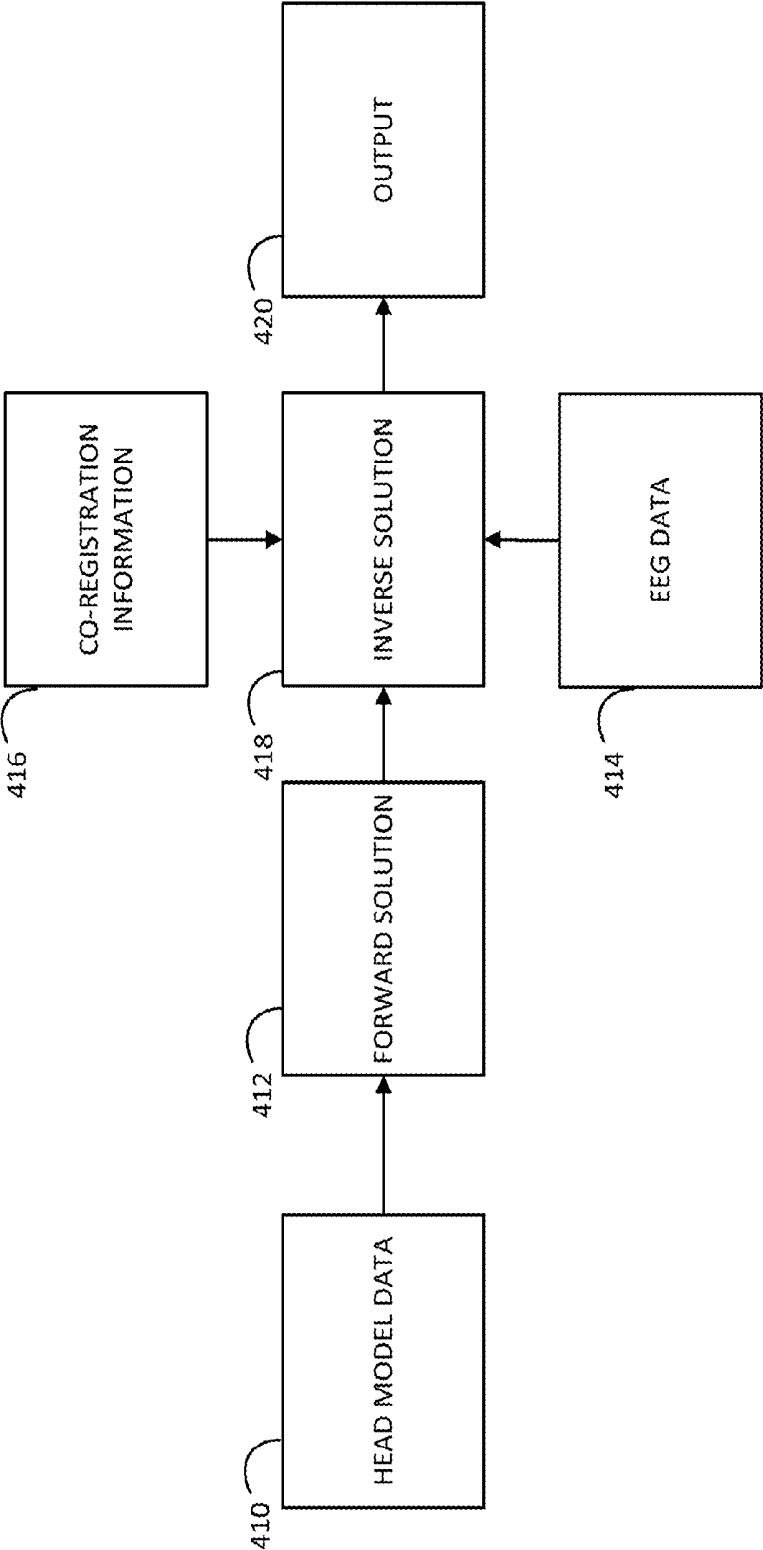

FIG. 4

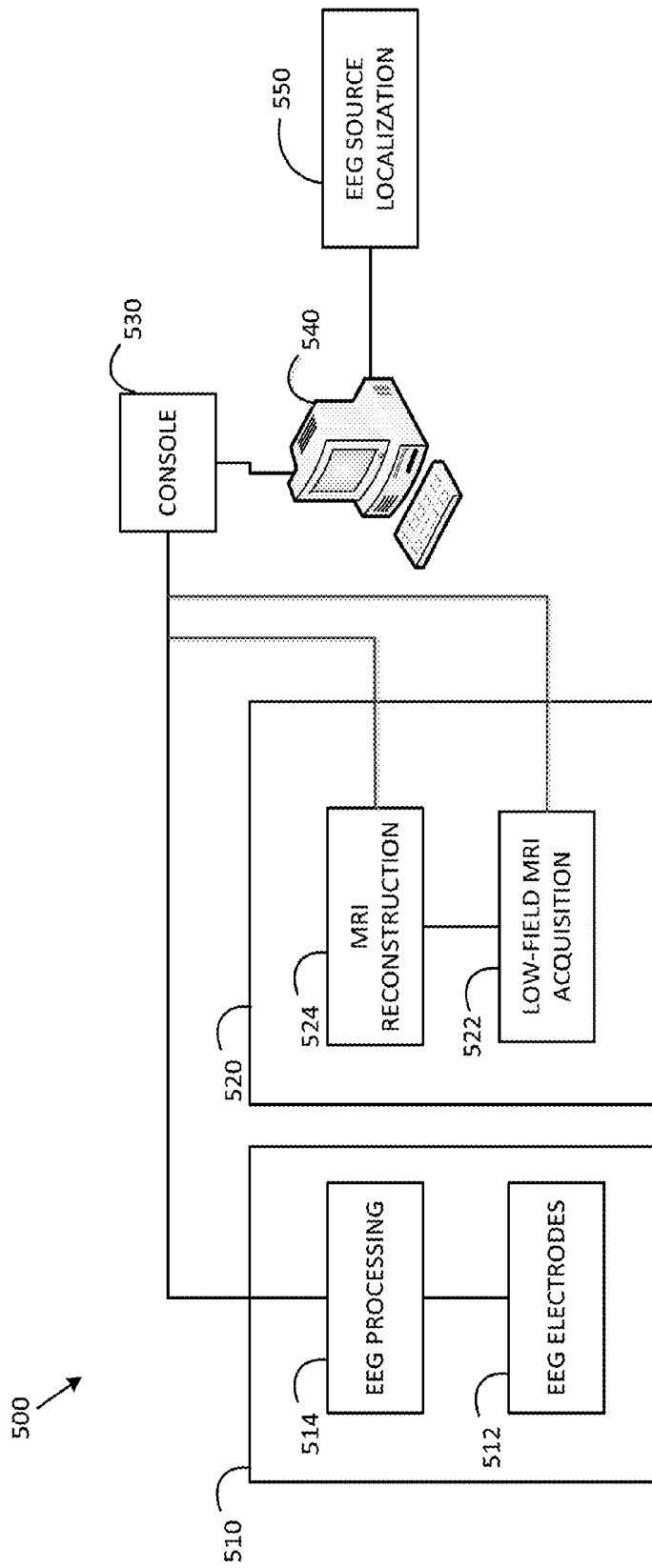

FIG. 5

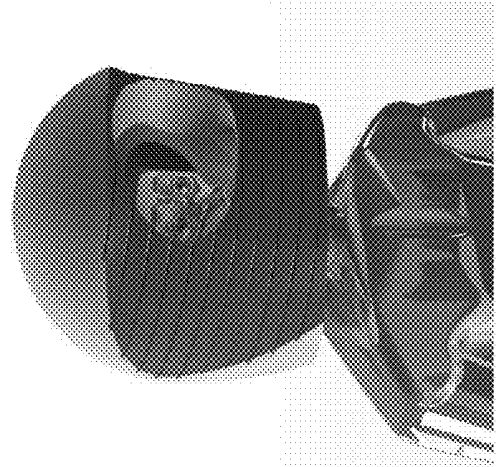

FIG. 6A

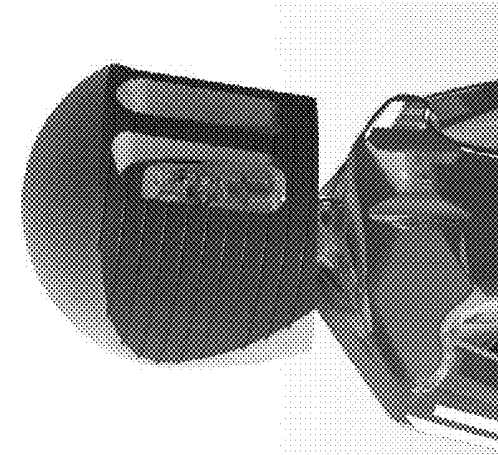

FIG. 6B

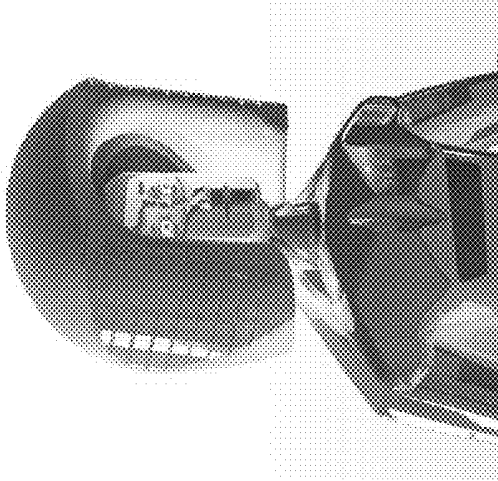

FIG. 6C

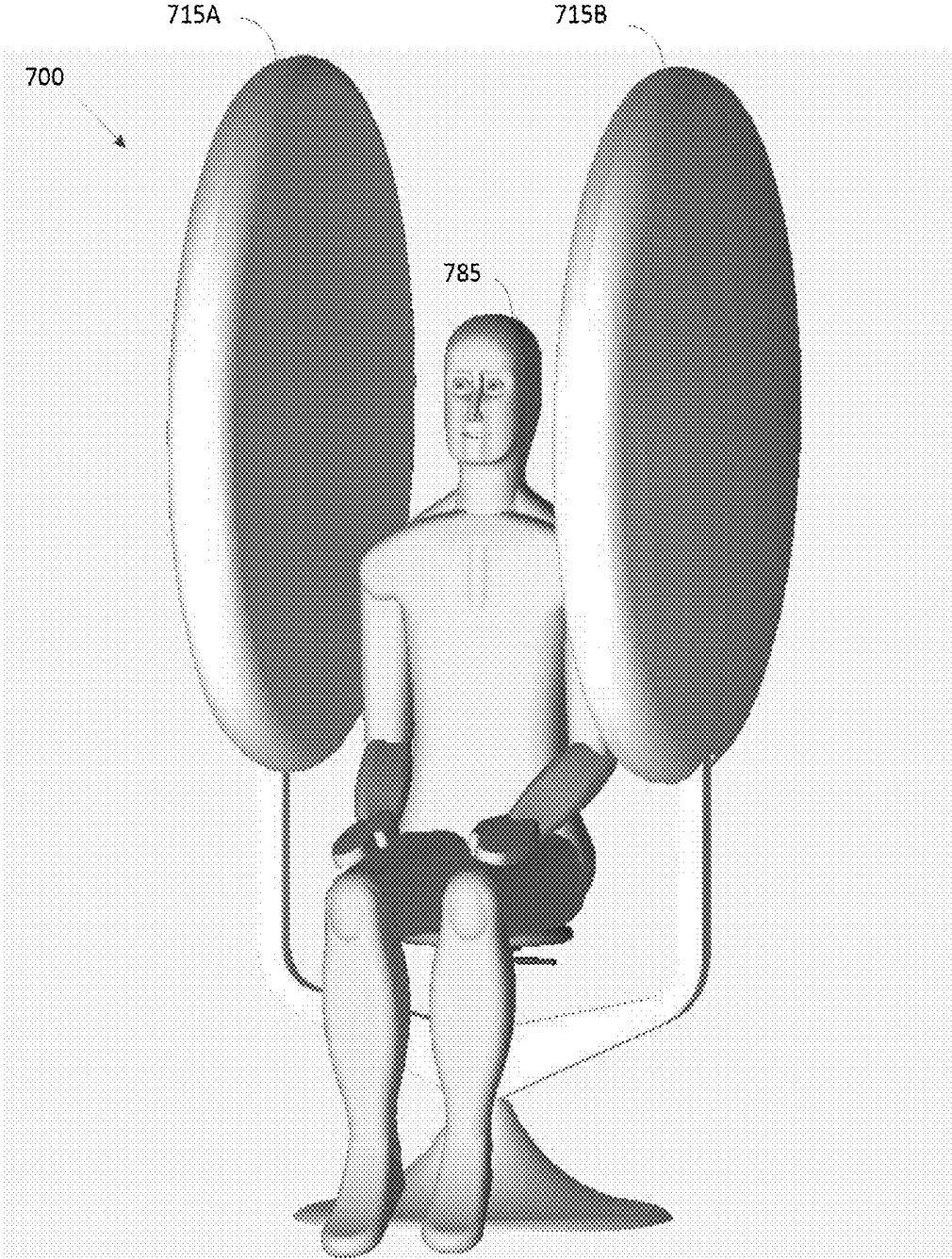
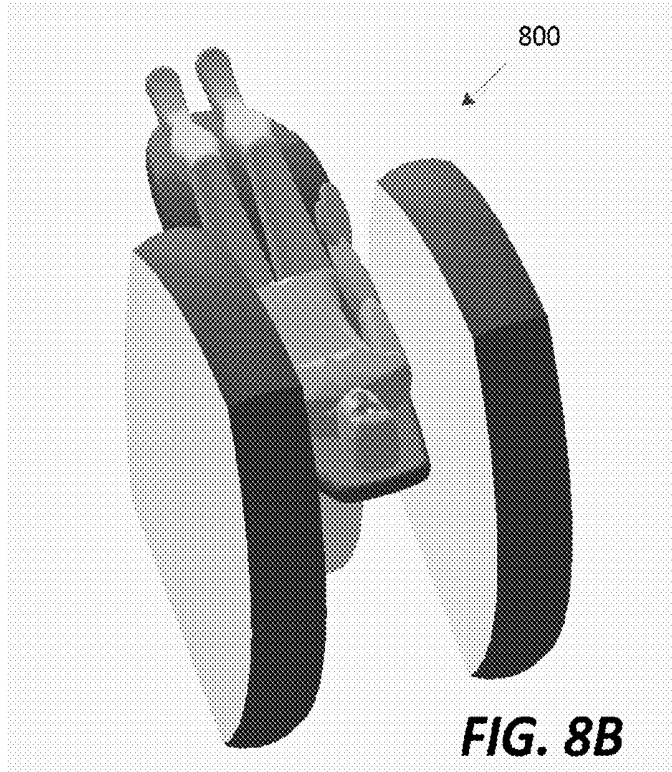
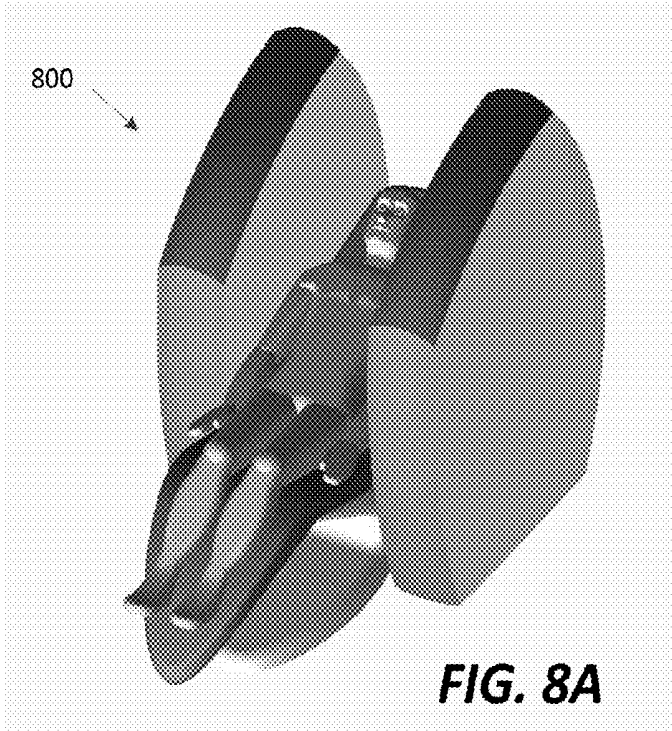

FIG. 7



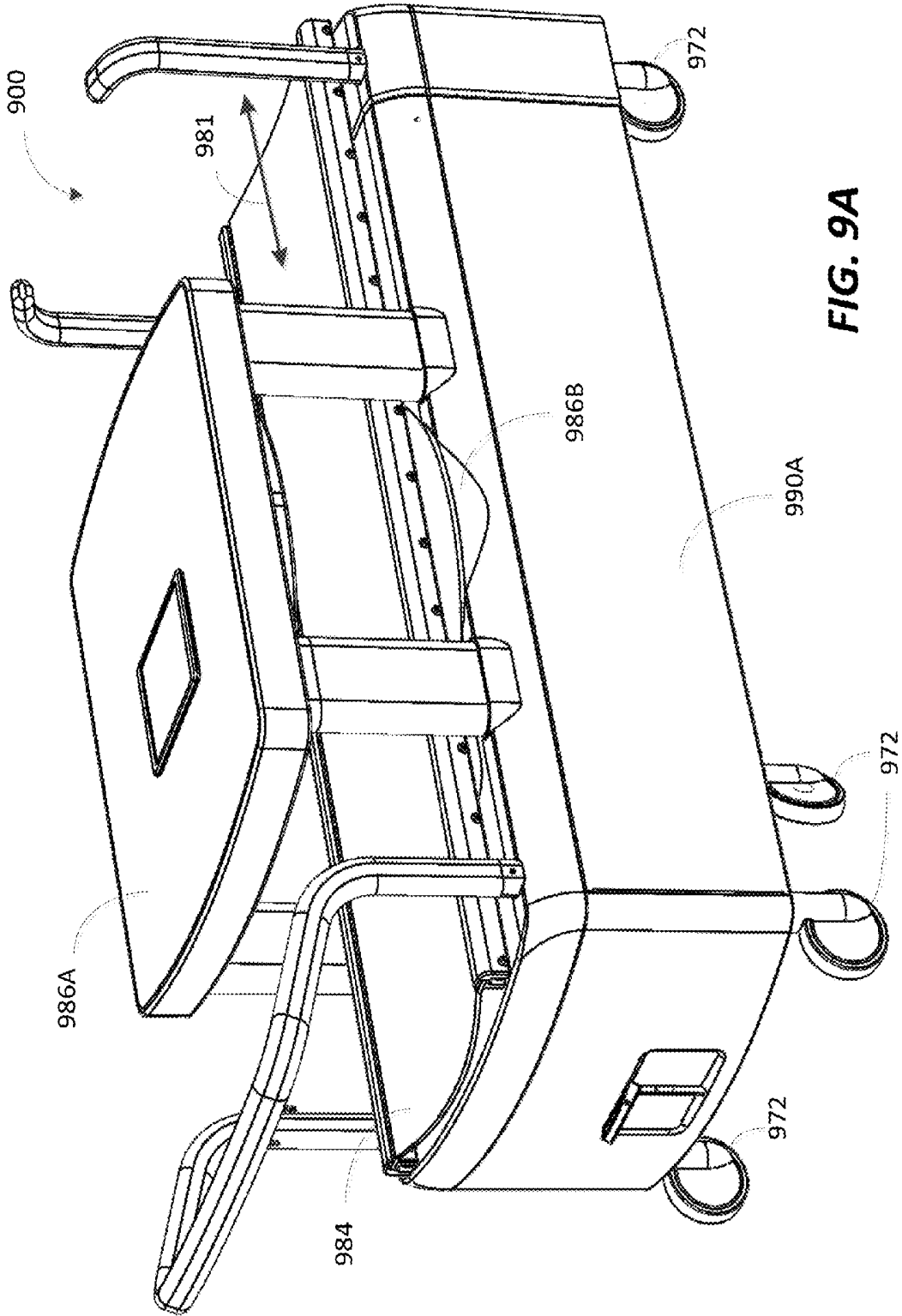

FIG. 9A

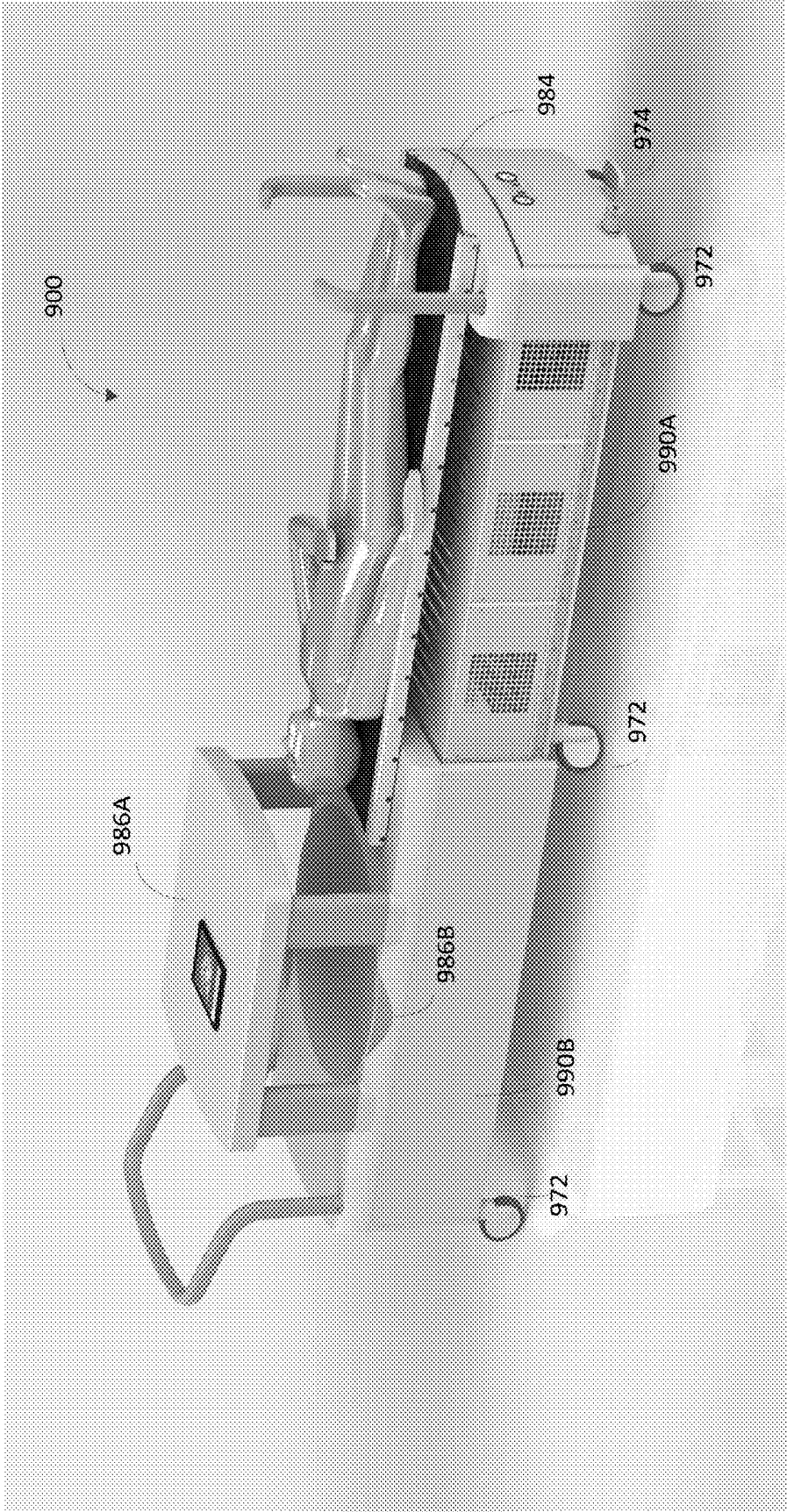

FIG. 9B

LOW FIELD MAGNETIC RESONANCE METHODS AND APPARATUS

[0001] This application claims priority under 35 U.S.C. §119(e) to U.S. Provisional Patent Application Ser. No. 62/078,383, filed Nov. 11, 2014 and entitled “Low Field Magnetic Resonance Methods and Apparatus,” which is herein incorporated by reference in its entirety.

BACKGROUND

[0002] Magnetic resonance imaging (MRI) provides an important imaging modality for numerous applications and is widely utilized in clinical and research settings to produce images of the inside of the human body. Generally, MRI is based on detecting magnetic resonance (MR) signals, which are electromagnetic waves emitted by atoms in response to state changes resulting from applied electromagnetic fields. For example, nuclear magnetic resonance (NMR) techniques involve detecting MR signals emitted from the nuclei of excited atoms upon the re-alignment or relaxation of the nuclear spin of atoms in an object being imaged (e.g., atoms in the tissue of the human body). Detected MR signals may be processed to produce images, which in the context of medical applications, allows for the investigation of internal structures and/or biological processes within the body for diagnostic, therapeutic and/or research purposes.

[0003] MRI provides an attractive modality for biological exploration due to the ability to non-invasively produce information on biological structure with relatively high resolution and contrast without the safety concerns of other modalities (e.g., without needing to expose the subject to ionizing radiation, e.g., x-rays, or introducing radioactive material to the body). Additionally, MRI is particularly well suited to provide soft tissue contrast, which can be exploited to image subject matter that other imaging modalities are incapable of satisfactorily imaging. Moreover, MR techniques are capable of capturing information about structures and/or biological processes that other modalities are incapable of acquiring. However, there are a number of drawbacks to MRI that, for a given imaging application, may involve the relatively high cost of the equipment, limited availability and/or difficulty in gaining access to clinical MRI scanners and/or the length of the image acquisition process.

[0004] The trend in clinical MRI has been to increase the field strength of MRI scanners to improve one or more of scan time, resolution, and contrast, which, in turn, continues to drive up costs. The vast majority of installed MRI scanners operate at 1.5 or 3 tesla (T), which refers to the field strength of the main magnetic field B_0 . A rough cost estimate for a clinical MRI scanner is on the order of one million dollars per tesla, which does not factor in the substantial operation, service, and maintenance costs involved in operating such MRI scanners.

[0005] Additionally, conventional high-field MRI systems typically require large superconducting magnets and associated electronics to generate a strong uniform static magnetic field (B_0) in which an object (e.g., a patient) is placed. The size of such systems is considerable with a typical MRI installment including multiple rooms for the magnet, electronics, thermal management system, and control console areas. The size and expense of MRI systems generally limits their usage to facilities, such as hospitals and academic research centers, which have sufficient space and resources to purchase and maintain them. The high cost and substantial

space requirements of high-field MRI systems results in limited availability of MRI scanners. As such, there are frequently clinical situations in which an MRI scan would be beneficial, but due to one or more of the limitations discussed above, is not practical or is impossible, as discussed in further detail below.

[0006] For the reasons described above, MRI is also attractive for use in conjunction with other modalities to facilitate a variety of different types of biological investigations, both for diagnostic and therapeutic purposes and for functional applications as well, as discussed in further detail below. For example, MRI may be used in conjunction with electroencephalography (EEG) to acquire structural brain data from which a patient-specific head model may be created to facilitate accurate source localization in EEG measurements. As another example, MRI has been used as an imaging tool to assist and/or guide surgeons such as in performing tissue ablation with focused ultrasound.

[0007] However, the drawbacks of high field MRI discussed above have a similar impact on combined modality procedures and is frequently a gating factor in the ability to perform them. In particular, the high cost and limited availability prevents these procedures from being performed except in exceptional circumstances. For example, when an MR image of a patient is required to generate an accurate head model for performing EEG source localization, the limited availability of MRI scanners restricts EEG-based functional neuroimaging to environments that include a high-field MRI system and to the rare circumstances where the substantial costs are justified. Additionally, high-field MRI equipment presents an obstacle to performing MRI-assisted surgical procedures. For example, high-field MRI scanners typically include a long cylindrical bore in which patients are inserted to perform imaging, which severely restricts access to the patient. Moreover, the high-field strength of clinical MRI systems prevents the use of any metal tools or instruments from being utilized in the vicinity of the MRI magnet.

SUMMARY

[0008] The inventors have recognized that the low field strengths and/or system configurations made possible by low field strengths of low-field MR facilitates its use with other clinical techniques, such as electrophysiological devices configured to obtain electrophysiological data. Obtained MR and electrophysiological data may be utilized in conjunction to improve diagnostic, therapeutic, functional and/or control applications, examples of which are described in further detail below.

[0009] Some embodiments include a system comprising a low-field magnetic resonance (MR) device, at least one electrophysiological device, and at least one controller configured to operate the low-field MR device to obtain MR data and to operate the at least one electrophysiological device to obtain electrophysiological data.

[0010] Some embodiments include a method of operating a system comprising a low-field magnetic resonance (MR) device and at least one electrophysiological device, the method comprising, while a patient is positioned within a field of view of the low-field MR device, operating the low-field magnetic resonance device to obtain MR data, and operating the at one electrophysiological device to obtain electrophysiological data.

[0011] Some embodiments include at least one computer readable medium having instruction encoded thereon that,

when executed by at least one processor, cause a method of operating a system comprising a low-field magnetic resonance (MR) device and at least one electrophysiological device to be performed, the method comprising, while a patient is positioned within a field of view of the low-field magnetic resonance device, causing operation of the low-field MR device to obtain MR data, and causing operation of the at one electrophysiological device to obtain electrophysiological data.

[0012] The inventors have recognized that the low field strengths and/or system configurations made possible by low field strengths of low-field MR facilitates its use with therapeutic techniques to guide one or more therapies.

[0013] Some embodiments comprise a system comprising a low-field magnetic resonance imaging device configured to obtain magnetic resonance (MR) data when operated with a patient within a field of view of the low-field magnetic resonance device, at least one controller configured to operate the low-field magnetic resonance device to obtain the MR data and configured to generate at least one MR image from the MR data, and at least one therapeutic device configured to deliver therapy to the patient within the field of view of the low-field magnetic resonance device, wherein the therapy is guided, at least in part, using the at least one MR image.

[0014] Some embodiments include a method of utilizing a low-field magnetic resonance imaging (MRI) device to assist in therapy, the method comprising, while a patient is located within a field of view of the low-field MRI device, operating the low-field MRI device to obtain MR data, generating at least one MR image from the MR data, and performing at least one therapeutic technique guided, at least in part, using the at least one MR image.

BRIEF DESCRIPTION OF THE DRAWINGS

[0015] Various aspects and embodiments of the disclosed technology will be described with reference to the following figures. It should be appreciated that the figures are not necessarily drawn to scale.

[0016] FIG. 1 illustrates a low-field MRI system including one or more electrophysiological sensors, in accordance with some embodiments;

[0017] FIGS. 2A and 2B illustrate a bi-planar magnet configuration, in accordance with some embodiments;

[0018] FIG. 3 illustrates components of an EEG system that may be used in accordance with some embodiments;

[0019] FIG. 4 illustrates a process for performing EEG source localization in accordance with some embodiments;

[0020] FIG. 5 schematically illustrates an integrated functional imaging system in accordance with some embodiments;

[0021] FIGS. 6A-6C illustrate brain imaging helmets that can be used to integrate low-field MRI with one or more electrophysiological modality;

[0022] FIG. 7 illustrates an exemplary seated bi-planar low-field MRI system for use in conjunction with one or more other modalities;

[0023] FIGS. 8A and 8B illustrate exemplary reclining bi-planar low-field MRI systems for use in conjunction with one or more other modalities; and

[0024] FIGS. 9A and 9B illustrate a transportable low-field MRI system, in accordance with some embodiments.

DETAILED DESCRIPTION

[0025] As discussed above, in addition to being a valuable stand-alone imaging modality, MRI has the possibility of being utilized in conjunction with other modalities and/or techniques to produce valuable new tools for diagnostic, therapeutic, functional or research purposes. However, the limitations of high-field MRI severely restricts the ability of MRI to be used in conjunction with other modalities/techniques in many circumstances, if it can be utilized at all. The inventors have recognized that low-field MRI may be utilized so as to make combined modality solutions a reality that can be widely deployed with high availability, and that can be employed in circumstances where high-field MRI simply cannot. As used herein, "high-field" refers generally to MRI systems presently in use in a clinical setting and, more particularly, to MRI systems operating with a main magnetic field (i.e., a B₀ field) at or above 1.5 T, though clinical systems operating between 0.5 T and 1.5 T are typically also considered "high-field." By contrast, "low-field" refers generally to MRI systems operating with a B₀ field of less than or equal to approximately 0.2 T.

[0026] The general trend in medical imaging has been to produce MRI scanners with increasingly greater field strengths, with the vast majority of clinical MRI scanners operating at 1.5 T or 3 T, with higher field strengths of 7 T and 9 T used in research settings. The appeal of high-field MRI systems include improved resolution and/or reduced scan times compared to lower field systems, motivating the push for higher and higher field strengths for clinical and medical MRI applications. However, as discussed above, increasing the field strength of MRI systems yields increasingly more expensive and complex MRI scanners, not only limiting availability and preventing their use as a general purpose and/or generally available imaging solution, but putting them further out of reach for use with other modalities and/or in connection with other clinical procedures, as discussed in further detail below.

[0027] The inventors have appreciated that low field MRI can be combined with one or more electrophysiological techniques, such as EEG, to produce a functional neuroimaging system that is affordable, can be widely deployed and can be manufactured with a relatively small footprint for flexible deployment and, in some embodiments, portability. According to some embodiments, such a functional neuroimaging system may be used for diagnosing and monitoring neurophysiological disease, and has remarkable potential to revolutionize the way that medical providers treat brain injury. From diagnosing epilepsy and stroke in developing countries to quickly evaluating brain trauma of accident victims to identifying concussion symptoms of athletes in contact sports, functional neuroimaging systems designed in accordance with the techniques described herein may, in some embodiments, allow for the rapid identification of brain trauma in environments where traditional high-field MRI is not available.

[0028] According to some embodiments, an electrophysiological measurement system, such as EEG, is combined with a low-field MRI system to provide spatiotemporal functional neuroimaging data that can be used as a diagnostic (e.g., to diagnose and monitor any of a large number of neurological disease states), for therapeutic purpose (e.g., to monitor brain activity during therapeutic procedures such as transcranial magnetic stimulation), or for functional application such as using the neuroimaging data in control applica-

tions (e.g., thought control for prosthetics, mind operation of systems and apparatus, gaming, etc.). It should be appreciated that low-field MRI may be combined with any electrophysiological technique and is not limited to EEG or the brain, and may include combinations with electrocardiography (ECG), electromyography (EMG), electrooculography (EOG), etc., to obtain spatiotemporal data of a wide array of physiological phenomena, as the aspects are not limited in this respect.

[0029] MR data and electrophysiological data may be combined in any of a variety of ways, including overlaying electrophysiological data on MRI data, displaying simultaneously acquired MRI data and electrophysiological data, or otherwise utilizing the MR data and electrophysiological data in conjunction. According to some embodiments, the electrophysiological data is transformed to one or more electrophysiological images (e.g., one or more EEG images), which can be utilized in conjunction with MRI data, for example, as an overlay, as supplementary information, to guide further acquisition of MR or electrophysiological data and/or to modify parameter(s) or characteristic(s) of the MR acquisition process, the electrophysiological acquisition process or both.

[0030] The inventors have further appreciated that low-field MRI may be utilized to assist surgeons in performing surgeries for which it is useful or, in some cases, critical to provide image data to guide or otherwise facilitate the surgical procedure. As discussed above, closed bore configurations of high field MRI (e.g., solenoid magnet configurations) restrict access to the patient and prevent high field MRI from being conveniently employed in many surgical procedures, if it can be employed at all. Low-field MRI systems can be constructed according to generally “open” configurations that greatly improve access to the patient, allowing for the potential of low-field MRI to be employed in a vastly increased number of surgical procedures. Additionally, the inventors have recognized that low-field strengths utilized in low-field MRI systems relax the strict limitations on the materials that can be located near the magnetics components of the system, thus facilitating the use of an increased array of tools and instruments that can be utilized during the procedure. For example, according to some embodiments, low-field MRI is utilized in combination with focused ultrasound to assist a surgeon in performing a tissue ablation procedure.

[0031] Following below are more detailed descriptions of various concepts related to, and embodiments of, methods and apparatus for combining low-field MRI with one or more other modalities and/or techniques. It should be appreciated that various aspects described herein may be implemented in any of numerous ways. Examples of specific implementations are provided herein for illustrative purposes only. In addition, the various aspects described in the embodiments below may be used alone or in any combination, and are not limited to the combinations explicitly described herein.

[0032] Low-field MR has been explored in limited contexts for non-imaging research purposes and narrow and specific contrast-enhanced imaging applications, but is conventionally regarded as being unsuitable for producing clinically-useful images. For example, the resolution, contrast, and/or image acquisition time is generally not regarded as being suitable for clinical purposes such as, but not limited to, tissue differentiation, blood flow or perfusion imaging, diffusion-weighted (DW) or diffusion tensor (DT) imaging, functional MRI (fMRI), etc. The inventors have developed techniques for producing improved quality, portable and/or lower-cost

low-field MRI systems that can improve the wide-scale deployability of MRI technology in a variety of environments beyond the large MRI installments at hospitals, designated MRI facilities and research institutions. The inventors have recognized that low-field MRI can be utilized with other modalities, such as EEG, to facilitate clinical diagnostic, therapeutic and functional activities previously unavailable or difficult to implement.

[0033] FIG. 1 is a block diagram of exemplary components of a MRI system 100. In the illustrative example of FIG. 1, MRI system 100 comprises workstation 104, controller 106, pulse sequences store 108, power management system 110, magnetics components 120, and electrophysiological sensor (s) 130. It should be appreciated that system 100 is illustrative and that a MRI system may have one or more other components of any suitable type in addition to or instead of the components illustrated in FIG. 1.

[0034] As illustrated in FIG. 1, magnetics components 120 comprises B_0 magnet 122, shim coils 124, RF transmit and receive coils 126, and gradient coils 128. B_0 magnet 122 may be used to generate, at least in part, the main magnetic field B_0 . B_0 magnet 122 may be any suitable type of magnet that can generate a main magnetic field (e.g., a low-field strength of approximately 0.2 T or less), and may include one or more B_0 coils, correction coils, etc. Shim coils 124 may be used to contribute magnetic field(s) to improve the homogeneity of the B_0 field generated by magnet 122. Gradient coils 128 may be arranged to provide gradient fields and, for example, may be arranged to generate gradients in the magnetic field in three substantially orthogonal directions (X, Y, Z) to localize where MR signals are induced.

[0035] RF transmit and receive coils 126 may comprise one or more transmit coils that may be used to generate RF pulses to induce a magnetic field B_1 . The transmit/receive coil(s) may be configured to generate any suitable type of RF pulses configured to excite an MR response in a subject and detect the resulting MR signals emitted. RF transmit and receive coils 126 may include one or multiple transmit coils and one or multiple receive coils. The configuration of the transmit/receive coils varies with implementation and may include a single coil for both transmitting and receiving, separate coils for transmitting and receiving, multiple coils for transmitting and/or receiving, or any combination to achieve single channel or parallel MRI systems. Thus, the transmit/receive magnetics component is often referred to as Tx/Rx or Tx/Rx coils to generically refer to the various configurations for the transmit and receive component of an MRI system. Each of magnetics components 120 may be constructed in any suitable way to, together, produce a low-field main magnetic field B_0 and to stimulate and detect MR signals.

[0036] Power management system 110 includes electronics to provide operating power to one or more components of the low-field MRI system 100. For example, as discussed in more detail below, power management system 110 may include one or more power supplies, gradient power amplifiers, transmit coil amplifiers, and/or any other suitable power electronics needed to provide suitable operating power to energize and operate components of the low-field MRI system 100.

[0037] As illustrated in FIG. 1, power management system 110 comprises power supply 112, amplifier(s) 114, transmit/receive switch 116, and thermal management components 118. Power supply 112 includes electronics to provide operating power to magnetics components 120 of the low-field MRI system 100. For example, power supply 112 may

include electronics to provide operating power to one or more B_0 coils (e.g., B_0 magnet **122**) to produce the main magnetic field for the low-field MRI system. In some embodiments, power supply **112** is a unipolar, continuous wave (CW) power supply, however, any suitable power supply may be used. Transmit/receive switch **116** may be used to select whether RF transmit coils or RF receive coils are being operated.

[0038] Amplifier(s) **114** may include one or more RF receive (Rx) pre-amplifiers that amplify MR signals detected by one or more RF receive coils (e.g., coils **124**), one or more RF transmit (Tx) amplifiers configured to provide power to one or more RF transmit coils (e.g., coils **126**), one or more gradient power amplifiers configured to provide power to one or more gradient coils (e.g., gradient coils **128**), shim amplifiers configured to provide power to one or more shim coils (e.g., shim coils **124**).

[0039] Thermal management components **118** provide cooling for components of low-field MRI system **100** and may be configured to do so by facilitating the transfer of thermal energy generated by one or more components of the low-field MRI system **100** away from those components. Thermal management components **118** may include, without limitation, components to perform water-based or air-based cooling, which may be integrated with or arranged in close proximity to MRI components that generate heat including, but not limited to, B_0 coils, gradient coils, shim coils, and/or transmit/receive coils. Thermal management components **118** may include any suitable heat transfer medium including, but not limited to, air and water, to transfer heat away from components of the low-field MRI system **100**.

[0040] As illustrated in FIG. 1, low-field MRI system **100** includes controller **106** (sometimes referred to as a console in the MRI context) configured to send instructions to and receive information from power management system **110**. Controller **106** may be configured to implement one or more pulse sequences, which are used to determine the instructions sent to power management system **110** to operate the magnetics components **120** in a desired sequence, for example, by operating the transmit coil(s) and/or the gradient coils in the particular sequence defined by the pulse sequence. A pulse sequence generally describes the order and timing in which transmit/receive coils and gradient coils operate to prepare the magnetization of the subject and acquire resulting MR data. For example, a pulse sequence may indicate an order of transmit pulses, gradient pulses, and acquisition times during which the receive coils acquire MR data.

[0041] Controller **106** may be configured to control power management system **110** to operate the magnetics components **120** in accordance with a balance steady-state free precession (bSSFP) pulse sequence, a low-field gradient echo pulse sequence, a low-field spin echo pulse sequence, a low-field inversion recovery pulse sequence, arterial spin labeling, diffusion weighted imaging (DWI), and/or any other suitable pulse sequence. Pulse sequences for low-field MRI may be applied for different contrast types such as T1-weighted and T2-weighted imaging, diffusion-weighted imaging, arterial spin labeling (perfusion imaging), Overhauser imaging, etc., each of which have a particular set of considerations in the low-field context. Controller **106** may be implemented as hardware, software, or any suitable combination of hardware and software, as aspects of the disclosure provided herein are not limited in this respect.

[0042] In some embodiments, controller **106** may be configured to implement a pulse sequence by obtaining informa-

tion about the pulse sequence from pulse sequences repository **108**, which stores information for each of one or more pulse sequences. Information stored by pulse sequences repository **108** for a particular pulse sequence may be any suitable information that allows controller **106** to implement the particular pulse sequence. For example, information stored in pulse sequences repository **108** for a pulse sequence may include one or more parameters for operating magnetics components **120** in accordance with the pulse sequence (e.g., parameters for operating the RF transmit and receive coils **126**, parameters for operating gradient coils **128**, etc.), one or more parameters for operating power management system **110** in accordance with the pulse sequence, one or more programs comprising instructions that, when executed by controller **106**, cause controller **106** to control system **100** to operate in accordance with the pulse sequence, and/or any other suitable information. Information stored in pulse sequences repository **108** may be stored on one or more non-transitory storage media.

[0043] As illustrated in FIG. 1, controller **106** also interacts with computing device **104** programmed to process received MR data. For example, computing device **104** may process received MR data to generate one or more MR images using any suitable image reconstruction process(es). Controller **106** may provide information about one or more pulse sequences to computing device **104** for the processing of data by the computing device. For example, controller **106** may provide information about one or more pulse sequences to computing device **104** and the computing device may perform an image reconstruction process based, at least in part, on the provided information.

[0044] Computing device **104** may be any electronic device, and typically includes one or more processors configured (e.g., programmed) to process acquired MR data and generate one or more images of the subject being imaged. In some embodiments, computing device **104** may be a fixed electronic device such as a desktop computer, a server, a rack-mounted computer, or any other suitable fixed electronic device that may be configured to process MR data and generate one or more images of the subject being imaged. Alternatively, computing device **104** may be a portable device such as a smart phone, a personal digital assistant, a laptop computer, a tablet computer, or any other portable device that may be configured to process MR data and generate one or images of the subject being imaged.

[0045] Controller **106** is further configured to send instructions to and receive information from physiological sensor(s) **130**. For example, physiological sensor(s) **130** may comprise a plurality of electrodes and associated electronics that form, at least in part, an EEG device capable of obtaining EEG data from a patient. Alternatively, or in addition to, physiological sensor(s) **130** may include electrophysiological sensors for performing electromyography (EMG), electrooculography (EOG), electrocardiography (ECG), or the like. In some embodiments, physiological sensor(s) **130** include optical imaging sensors. In yet other embodiments, physiological sensor(s) **130** includes one or more ultrasound transducers to facilitate ultrasound imaging. Other types of physiological sensor(s) may also be used, as the aspects are not limited in this respect. Controller **106** may be configured to send/receive information to any one or combination of physiological sensors **130** that are provided to operate in conjunction with the low-field MRI system, examples of which are described in further detail below.

[0046] It should be appreciated that controller **106** may be a single integrated controller or may comprise separate controllers to perform functions of system **100**. In some embodiments, computing device **104** may comprise multiple computing devices of any suitable type, as the aspects are not limited in this respect. A user **102** may interact with computing device **104** (e.g., a workstation) to control aspects of the low-field MR system **100** (e.g., program system **100** to operate in accordance with a particular pulse sequence, adjust one or more parameters of the system **100**, operate physiological sensor(s), etc.) and/or view images obtained by the low-field MR system **100**. According to some embodiments, computing device **104** and controller **106** form a single controller, while in other embodiments, computing device **104** and controller **106** each comprise one or more controllers. It should be appreciated that the functionality performed by computing device **104** and controller **106** may be distributed in any way over any combination of one or more controllers, as the aspects are not limited for use with any particular implementation or architecture. Controller **106** and computing device **104** typically comprise one or more processors capable of executing instructions embodied in computer code, such as software programs, firmware instructions, etc. to perform one or more functions in connection with the operation of system **100**.

[0047] FIGS. 2A and 2B illustrate bi-planar magnetic configurations that may be used in a low-field MRI system suitable for use with techniques described herein. FIG. 2A schematically illustrates a bi-planar magnet configured to produce, at least in part, a portion of a B_0 field suitable for low-field MRI. Bi-planar magnet **200** comprises two outer coils **210a** and **210b** and two inner coils **212a** and **212b**. When appropriate current is applied to the coils, a magnetic field is generated in the direction indicated by the arrow to produce a B_0 field having a field of view between the coils that, when designed and constructed appropriately, may be suitable for low-field MRI. The term “coil” is used herein to refer to any conductor or combination of conductors of any geometry having at least one “turn” that conducts current to produce a magnetic field, thereby forming an electromagnet.

[0048] It should be appreciated that the bi-planar geometry illustrated in FIG. 2A is generally unsuitable for high-field MRI due to the difficulty in obtaining a B_0 field of sufficient homogeneity at high-field strengths. High-field MRI systems typically utilize solenoid geometries (and superconducting wires) to achieve the high field strengths of sufficient homogeneity for high-field MRI. The bi-planar B_0 magnet illustrated in FIG. 2A provides a generally open geometry, facilitating its use in many circumstances where high-field MRI systems cannot. For example, generally open geometries provide improved access to patients to facilitate combining low-field MRI with one or more other modalities, techniques and/or surgical procedures, including those that are difficult or impossible using conventional high-field closed bore configurations. Also, open geometries can be used with patients who suffer from claustrophobia and may refuse to be imaged with conventional high-field solenoid coil geometries. Furthermore, the bi-planar design may facilitate use with larger patients as a result of its open design and, in some instances, a generally larger field of view possible at low-field strengths and homogeneity requirements. Moreover, the generally open design facilitates access to the patient being imaged and

may improve the ability to position a patient within the field of view, for example, an unconscious, sedated or anesthetized patient.

[0049] As discussed above, the inventors have further recognized that open geometries allow access to the patient, facilitating the use of MRI during other clinical procedures such as during a surgery or other procedures where some measure of access to the patient is desired or required. In general, combining MRI with other modalities and/or clinical procedures is not possible using conventional MRI due to the closed configuration and/or the high field-strengths involved, as discussed in further detail below. The bi-planar geometry in FIG. 2A is merely exemplary, and other configurations may be used. For example, according to some embodiments, a “one-sided” geometry is used wherein the B_0 magnet essentially consists of single side, in contrast to the pair of opposing sides in the bi-planar geometry illustrated. One-sided geometries provide substantially full access to the patient being imaged.

[0050] FIG. 2B illustrates a hybrid bi-planar magnet using laminate techniques to fabricate a B_0 magnet or portion thereof and/or to fabricate one or more other magnetics components for use in low-field MRI. For example, in the exemplary bi-planar magnet **200'** illustrated in FIG. 2B, laminate panels **220a** and **220b** replace inner coils **212a** and **212b** to produce a hybrid magnet. Laminate panels **220a** and **220b** may include any number of laminate layers having fabricated thereon one or more B_0 coils, gradient coils, correction coils and/or shim coils, etc. or portions thereof to facilitate production of the magnetic fields used in low-field MRI. Suitable hybrid magnets using laminate techniques are described in U.S. patent application Ser. No. 14/845,652 ('652 application), filed Sep. 4, 2015 and titled “Low Field Magnetic Resonance Imaging Methods and Apparatus,” which is herein incorporated by reference in its entirety. In other embodiments, laminate techniques can be used to implement the B_0 magnet in its entirety (e.g., replacing coils **210a** and **210b**).

[0051] Exemplary laminate panels **220a** and **220b** may, additionally or alternatively, have fabricated thereon one or more gradient coils, or portions thereof, to encode the spatial location of received MR signals as a function of frequency or phase. According to some embodiments, a laminate panel comprises at least one conductive layer patterned to form one or more gradient coils, or a portion of one or more gradient coils, capable of producing or contributing to magnetic fields suitable for providing spatial encoding of detected MR signals when operated in a low-field MRI system. For example, laminate panel **220a** and/or laminate panel **220b** may comprise a first gradient coil configured to selectively vary the B_0 field in a first (X) direction to perform frequency encoding in that direction, a second gradient coil configured to selectively vary the B_0 field in a second (Y) direction substantially orthogonal to the first direction to perform phase encoding, and/or a third gradient coil configured to selectively vary the B_0 field in a third (Z) direction substantially orthogonal to the first and second directions to enable slice selection for volumetric imaging applications.

[0052] Exemplary laminate panels **220a** and **220b** may, additionally or alternatively, include additional magnetics components such as one or more correction or shim coils arranged to generate magnetic fields in support of the system to, for example, increase the strength and/or improve the homogeneity of the B_0 field, counteract deleterious field effects such as those created by operation of the gradient

coils, loading effects of the object being imaged, other equipment in proximity or being used in conjunction, or to otherwise support the magnetics of the low field MRI system. The bi-planar magnet illustrated in FIGS. 2A and 2B, may be produced using conventional coils, laminate techniques, or a combination of both, and may be used to provide magnetics components for a low-field MRI system, as discussed in further detail below.

[0053] As discussed above, the inventors have recognized that low-field MRI systems, such as those described above and in the '652 application, may be combined with an electrophysiological measurement system, such as an EEG system, to provide a portable and/or lower-cost functional imaging system capable of performing patient-specific source localization of the electrophysiological measurements. Measurements of electrical activity within the body using one or more electrodes placed on the surface of the body have long been a valuable source of information for characterizing and diagnosing human biological processes. In EEG, electrodes are placed on the scalp and the electrical signals reflecting biological activity of neurons in the brain are measured. EEG measurements are safe and the technique is relatively easy to use even in very young children. EEG signals are thought to arise from the summation of the synchronous activity of thousands or millions of similarly-oriented neurons. In particular, EEG signals are believed to derive from pyramidal cells aligned in parallel in the cerebral cortex and hippocampus, which act as many interacting nonlinear oscillators, and thus can be used as an indicator of brain activity.

[0054] EEG signals conventionally represent electrical activity as a function of time. The temporal resolution of electrophysiological data acquisition including EEG can be on the order of milliseconds, such that neuronal events occurring over short timescales can be identified in the obtained signals. EEG signals may be obtained continuously over a period of time (e.g., 20-30 minutes) to detect the brain's spontaneous electrical activity. Alternatively, EEG signals time-locked to the repeated presentation of a stimulus may be obtained and a plurality of time periods (also called "epochs") corresponding to the time-locked signals may be averaged to study evoked potentials (EP) representing the brain's response to the presentation of the stimulus. In a clinical setting, EEG is often used to diagnose and/or monitor neurological diseases including epilepsy, stroke, sleep disorders, coma, tumors, and other focal-brain disorders by analyzing the spectral content of continuously-obtained EEG signals to determine changes in neuronal oscillations, which represent synchronized activity for networks of neurons in the brain.

[0055] FIG. 3 illustrates a block diagram of an EEG system 300 that may be used in accordance with some embodiments. The EEG system includes a plurality of EEG electrodes 310 designed to be affixed to the surface of a patient's head and configured to obtain EEG data from the patient. Any suitable type of EEG electrodes including, but not limited to, metal ring-shaped electrodes, may be used. Frequently, the plurality of electrodes are sewn onto a stretchable cap which the patient may wear to facilitate placement of the electrodes on the patient's head. Any suitable number of electrodes may be used, and embodiments are not limited in this respect. Commercially-available EEG caps often include 32, 64, 128, or 256 electrodes, and are available in different sizes for patients with different size heads. The EEG electrodes are connected to system electronics, described in more detail below, by

wires or "leads," which transmit the small EEG signals obtained by the electrodes to the EEG system electronics for amplification and processing.

[0056] EEG system 300 may include buffer amplifiers 312, which receive the output of the EEG electrodes. The buffer amplifiers operate to stabilize the obtained EEG signals and typically amplify them by a desired factor (e.g., a factor of two, five, ten, etc.) The buffer amplifiers 312 then provide the EEG signals to differential pre-amplifiers, which filter and may further amplify the EEG signals (e.g., by a factor of 2, 5, 10, 50, 100, etc.). EEG system 300 also includes power isolation components 316 configured to isolate the main power electronics of the EEG system from the patient to mitigate the possibility of accidental electric shock. Any suitable power isolation components including, but not limited to, optical isolation components may be used.

[0057] Powered amplifiers 318 may further amplify the EEG signals output from the differential pre-amplifiers 314 and convert the obtained analog EEG signals into digital signals for processing by processor 320. A/D conversion may then convert the signal for each electrode into a "channel" of EEG data that can be digitally processed. Processor 320 may be programmed to perform particular digital signal processing functions on the data in each EEG channel. The digital signal processing functions may include, but are not limited to, filtering 322, averaging 324, and artifact rejection 326, etc. EEG system 300 also may include display 328 configured to display the output of processor 320. For example, display 328 may be configured to display signal traces for each of the EEG channels, and the signal traces may be updated as the EEG data is being obtained.

[0058] EEG signals may also be used to perform source localization or estimation, which refers to the process of identifying locations of the brain that give rise to detected signals. Performing source localization provides spatial information about detected EEG signals. For example, source localization can be used to convert electrical signals obtained as a function of time to electrical signals as a function of space. The resulting electrical signals as a function of space can be presented as one or more images to facilitate visualization, analysis and/or further processing of the electrical activity of the brain. In general, source estimation or localization refers to any technique that provides spatial information regarding the location of the source of acquired electrophysiological data (e.g., EEG data). Determining a unique current source in the brain for a given EEG signal is typically not possible because some currents in the brain produce electric potentials that cancel each other out. To solve this "inverse problem," EEG source estimation techniques typically require making assumptions about the likely location and number of current sources in the brain to constrain the solution space and select among competing hypotheses. Because each patient's brain anatomy is different, an important assumption that facilitates accurate EEG source localization is determining an appropriate head model to use for generating a "forward solution." The forward solution represents the brain anatomy of a patient and is used to constrain solutions of the inverse problem to include only sources corresponding to the forward solution.

[0059] As discussed above, high-field magnetic resonance imaging (MRI) has been used to acquire structural brain data from which a patient-specific head model may be created. EEG source estimation or localization can then be performed with a higher degree of accuracy for the specific patient from

which the EEG signals are obtained. However, despite the widespread clinical use of EEG systems, EEG source localization techniques are severely limited based on the cost and relative unavailability of MRI systems capable of capturing an MR image of patients on whom the EEG is obtained. Additionally, because most EEG systems include metal electrodes, they cannot be safely used in a high-field MRI scanner, further limiting the use of conventional high-field MRI in connection with EEG.

[0060] Moreover, as discussed in further detail below, EEG source localization requires the alignment of the EEG head coordinate system with the patient's MRI data to produce accurate source localization. The EEG head coordinate system is typically determined using a 3-D digitization system that captures spatial locations of multiple points on the surface of the patient's head prior to, during, or after collection of the EEG data. Alignment of the MRI data with the EEG head coordinate system is then achieved using manual co-registration of points on the patient's MRI with the digitized points in the EEG head coordinate system. Errors in the 3-D digitization and/or co-registration process result in EEG source localization errors. As discussed in further detail below, some embodiments are directed to a functional neuroimaging system including an integrated low-field MRI system and an electrophysiological measurement system, such as EEG, that facilitates the alignment of EEG data and MRI data.

[0061] Because MRI data of sufficient resolution was previously only available from high-field MRI scanners, the cost, lack of availability and other drawbacks associated with high-field MRI equipment prevented the use of MRI to perform source localization of electrophysiological measurements from being a feasible tool in most clinical situations, relegating its use instead to extraordinarily limited circumstances. Thus, the inventors' recognition that low-field MR systems may be configured for use in EEG source localization enables the provision of a relatively low cost electrophysiological imaging system, not previously available, that can be utilized in a wide variety of clinical diagnostic and therapeutic procedures. The inventors have appreciated that such systems also open up the possibility of developing control systems based on obtained electrophysiological data.

[0062] FIG. 4 illustrates a process for performing source localization of electrophysiological measurements, in accordance with some embodiments. While the following description is provided in the context of EEG data, it should be appreciated that the same techniques can be used to perform source localization (e.g., obtain spatial information regarding obtained data) on any type of electrophysiological data, including EEG, ECG, EMG, EOG or any other type of electrophysiological data, as the techniques are not limited for use with any particular type of data. For example, MR data may be used to constrain the inverse problem so that spatial information may be obtained from any of various types of electrophysiological data.

[0063] In act 410, head model data is acquired using a low-field MRI device. Any low-field MRI device capable of producing an image of satisfactory resolution for performing electrophysiological source localization may be used, and embodiments are not limited in this respect. For example, any of the low field MRI systems or configurations described in the '652 application may be used, or any other suitable system or configuration for providing low-field MR data may be used, as source localization of electrophysiological measurements is not limited for use with any particular low-field MR

apparatus. In some embodiments, the low-field MRI device is configured to produce an image of a resolution higher than or equal to an in-plane resolution of three millimeters. Such a resolution may enable discerning of the layers of the boundary element model or other source space model used for electrophysiological source localization. In some embodiments, the low-field MRI device is configured to produce an image having a resolution of 3×3×3 millimeters isotropic. In other embodiments, the low-field MRI device is configured to produce an image having a resolution of 1×1×1 millimeters isotropic. However, other resolutions (both isotropic and anisotropic) may be used, as the techniques described herein are not limited for use with any particular resolution or range of resolutions.

[0064] The process then proceeds to act 412, where the head model data is used to generate a forward solution. Any suitable forward solution may be used including, but not limited to, a forward solution based on a spherical model, a boundary element model (BEM), a finite element model (FEM), or a finite difference method (FDM). In some embodiments, a BEM having at least three layers is used to model the skull, cerebrospinal fluid (CSF), and the brain surface, each of which may be modeled as having different tissue conductivities.

[0065] The process then proceeds to act 414, where EEG data is collected. Any suitable type of EEG system may be used, and embodiments are not limited in this respect. In some embodiments, an EEG system having components similar to those described above with regard to FIG. 3 may be used. In some embodiments, at least some of the electronics used for the EEG system may be shared with the low-field MRI system to produce an integrated system that is compact and lower cost than providing the EEG system and the MRI system separately. Because there are no safety concerns using metal EEG electrodes with a low-field MRI device, standard conventional EEG systems that include such electrodes may be used further reducing the cost of the system and improving the deployability of some embodiments.

[0066] The process then proceeds to act 416, where co-registration information is obtained. The co-registration information may be obtained in any suitable way using any suitable type of registration system. For example, the co-registration information may be obtained using a conventional 3-D digitization system, as discussed above. In some embodiments, the co-localization of the low-field MRI device and the EEG system provides for co-registration techniques not possible with conventional EEG systems. For example, in some embodiments the co-registration information may be obtained directly by the low-field MRI system itself before, during, or after obtaining of the EEG data. As discussed in more detail below, direct acquisition of the co-registration data by the low-field MRI device may facilitate the correction of artifacts including, but not limited to, patient motion.

[0067] The process then proceeds to act 418, where the inverse solution for localizing EEG sources in the brain of the patient is determined based, at least in part, on the forward solution, the EEG data, and the co-registration information. Any suitable technique or techniques may be used to determine the inverse solution. For example, in some embodiments, sources in the brain giving rise to the obtained EEG signals on the scalp are modeled as one or more electric dipoles. The process then proceeds to act 420, where the source localization results are output. For example, an image of the patient's brain as captured using the low-field MRI

device may be displayed on a display, and one or more EEG sources (e.g., electric dipoles) corresponding to the solution of the inverse solution may be shown overlaid on the displayed image.

[0068] In some embodiments, the EEG source analysis may be used to characterize particular neurological disease states (e.g., Parkinson's syndrome, schizophrenia, traumatic brain injury, stroke, Alzheimer's disease, etc.). For example, one or more neurological conditions may be characterized by temporal and/or spatial correlations observed in the EEG data and/or the EEG source analysis, and an EEG "signature" or "signatures" template corresponding to the neurological disease state may be stored in a library of disease states. The library of disease states may be used as an assessment tool in analyzing and characterizing EEG data collected from a patient by finding the closest match to the template in the library. Such a technique would enable EEG-based "fingerprinting" providing physicians with a useful tool in diagnosing and/or monitoring neurological diseases.

[0069] According to some embodiments, clustering techniques (e.g., statistical clustering techniques such as K-means, Gaussian mixture models (GMMs), support vector machines (SVMs), etc.) may be used to cluster and classify EEG images obtained via the techniques described herein or information derived from such images that are known to correspond to various states of interest (e.g., any of various healthy or diseased states for which clustering and classification is desired). The resulting clusters may be labeled and used as a model for later classifying new EEG images (or information derived therefrom). For example, new EEG data may be compared to the model to characterize the EEG data relative to the clusters captured by the model to evaluate similarities/dissimilarities between the EEG data and the known states associated with the modeled clusters. Such classification can be used to characterize obtained EEG data as diseased or healthy, to assist in identifying various neurological disorders, or to otherwise classify functional neuroimaging data.

[0070] As discussed briefly above, in some embodiments, a low-field MRI device may be configured to determine co-registration information for spatially aligning obtained EEG data with a patient's MRI data obtained by the MRI device. For example, the EEG system may include one or more markers that can be placed on the patient's head, and the low-field MRI system may be configured to determine a spatial position of the one or more markers to define the EEG head coordinate system. Any suitable marker(s) detectable by the low-field MRI system may be used. In some embodiments, at least one of the markers is an EEG electrode used to obtain EEG data. Additionally, or alternatively at least one of the markers may be separate from the EEG electrodes used to obtain EEG data. The marker(s) may be placed at any suitable location on the patient's head including, but not limited to, locations such as theinion or nasion and the left and right pre-auricular points, which are typically digitized using a conventional 3D digitizer to define the EEG head coordinate system.

[0071] In embodiments where the low-field MRI device is configured to determine co-registration information by detecting one or more markers, the co-registration information may be obtained at any suitable time and/or at any suitable frequency. For example, the co-registration information may be continuously determined during an MRI scan by the low-field MRI device. Alternatively, the co-registration infor-

mation may be determined periodically or in response to a user input to instruct the MRI system to determine the co-registration information.

[0072] Typically, when EEG data is combined with high-field MRI data, the EEG data and the high-field MRI data are obtained using different systems that do not communicate with each other. An integrated EEG and low-field MRI system, in accordance with some embodiments, provides communication and control benefits not possible with conventional EEG or MRI systems which obtain data in isolation. For example, data obtained using the EEG system may be used to modify one or more parameters of the low-field MRI system and/or the MRI data obtained using the low-field MRI system may be used to modify one or more acquisition parameters of the EEG system. Such feedback may inform the functional neuroimaging process to ensure that the data obtained is of sufficient quality to perform accurate EEG source localization. In addition, integrating low-field MR and EEG in a single system significantly simplifies the process and workflow and is significantly more convenient for patient and physician. For example, one or more of field of view, signal-to-noise ratio, resolution, etc. may be modified based on obtained EEG data. For example, EEG data may be used to identify a particular portion of anatomy at which to acquire further MR data and/or to acquire MR data at a higher resolution and/or SNR.

[0073] An EEG system may include one or more components (e.g., metal EEG electrodes) that when placed inside of the low-field MRI device are likely to perturb the homogeneity of the B_0 field causing it to become less homogeneous. In some embodiments, the B_0 field of the low-field MRI device may be modified to improve the homogeneity of the B_0 field in the presence of the metal component(s) of the EEG system. For example, the low-field MRI device may include shimming elements (e.g., shim coils) that may be appropriately positioned and/or activated to correct the field distortion introduced by the metal component(s) to improve the homogeneity of the B_0 field. Any of the static or dynamic shimming techniques and/or field sensing techniques described in the '652 patent may be utilized to adjust the B_0 field to achieve desired field strength and homogeneity for the particular environment and loading conditions in which the MRI system is operating such as those that may arise when operating a low-field MRI system in the presence of one or more other electrophysiological measurement devices, such as EEG.

[0074] According to some embodiments, one or more characteristics or parameters of the low-field MRI system may be modified based, at least in part, on an EEG source localization result. For example, initial MRI data obtained by the low-field MRI device may be used to create a forward model, and the forward model may be used for EEG source localization, as discussed above. Depending on the EEG source localization result, one or more characteristics or parameters of the low-field MRI device may be modified and additional MRI data may be obtained by the low-field MRI device. This process may be repeated until an EEG source localization result of a desired quality is obtained. Any metric or metrics may be used to determine whether an EEG source localization result is of a desired quality, and embodiments are not limited in this respect.

[0075] Because the EEG system and the low-field MRI device are co-located and in communication with one another, in some embodiments, EEG source localization may be performed in essentially real-time using the obtained MRI

data and EEG data. The EEG source localization process may be fully or partially automated to enable one or more EEG sources to be localized in the brain of a patient without or with minimal human intervention.

[0076] As discussed above, the integration of a low-field MRI device and an EEG system in accordance with some embodiments, enables one or more scanning parameters of the low-field MRI device to be modified based, at least in part, on information from the EEG system. Additionally, the integration may also enable information obtained by the low-field MRI device to modify one or more acquisition parameters of the EEG system. For example, the low-field MRI device may be configured to detect motion of an imaged patient, and the EEG system may be configured to discard at least some obtained EEG data based, at least in part, on the detected motion. The determination of whether to discard EEG data may be made based, at least in part on whether the amount of detected patient motion is greater than a threshold value. In some embodiments, the EEG data obtained during detected patient motion may be associated with an identifier, but may not actually be discarded.

[0077] In some embodiments, the EEG system may be configured to detect patient motion and at least one scanning parameter of the low-field MRI device may be modified based, at least in part, on the detected patient motion. For example, the low-field MRI device may be configured to discard at least some obtained MRI data in response to the detected patient motion and MRI data corresponding to the discarded MRI data may optionally be automatically re-acquired. Information other than patient motion may additionally or alternatively be detected by the EEG system, the low-field MRI device, or both systems to provide feedback that modifies how one or both of the systems acquire data, and patient motion is described as an example.

[0078] FIG. 5 schematically illustrates components of an integrated functional neuroimaging system 500 in accordance with some embodiments. System 500 includes EEG system 510 and low-field MRI system 520. FIG. 5 shows EEG system 510 operatively connected to low-field MRI system 520 via console 530. However, it should be appreciated that the EEG system and the MRI system may be connected in any other suitable way including, but not limited to, being directly connected by one or more communications cables configured to transmit information between the systems.

[0079] EEG system 510 includes EEG electrodes configured to acquire EEG data. The acquired EEG data is sent to EEG processing component 514, where the acquired EEG data is processed by, for example, filtering, amplifying, averaging, etc., as discussed above in connection with the illustrative EEG system shown in FIG. 3. EEG system 510 may include other components not shown in FIG. 5 including, but not limited to, the EEG components shown in FIG. 3.

[0080] Low-field MRI system 520 includes low-field MRI acquisition components 522 configured to acquire low-field MRI data. Low-field MRI acquisition components 522 may include, but are not limited to, magnetics for producing a B_0 field, gradient coils, control electronics, temperature control (e.g., cooling) systems, amplifiers, electromagnetic shielding, operating power systems, and RF coils configured to perform one or both of transmitting RF energy and detecting RF echoes. Any suitable low-field MRI device configuration may be used including, but not limited to, a bi-planar configuration (e.g., as shown in FIG. 1) and a solenoid configuration. MRI data acquired by low-field MRI acquisition com-

ponents 522 is sent to MRI reconstruction component 524, where an MR image is reconstructed based, at least in part, on the obtained MRI data. In some embodiments, functional neuroimaging system 500 includes at least one additional receive coil (not shown) to enable active noise cancellation. Any suitable type of additional receive coil may be used, and embodiments are not limited in this respect.

[0081] Functional neuroimaging system 500 also includes console 530, which may include one or more processors programmed to generate MRI pulse sequences used to acquire data using low-field MRI system 520 and/or issue control instructions to EEG system 510. Additionally, console 530 may be configured to perform any other suitable operation. In some embodiments, console 530 may be configured to receive MR data detected by one or more receive coils of low-field MRI system 520 and provide the received MR data to workstation 540 for processing the data (e.g., to reconstruct one or more MRI images). In some embodiments, console 530 may be configured to receive obtained EEG data and/or co-registration information in addition to MR data, and workstation 540 may be programmed to process the obtained MR and EEG data to perform EEG source localization 550.

[0082] Aspects of the EEG system 510 and low-field MRI system 520 may be integrated in any suitable way to provide benefits not achievable using separate conventional EEG and low-field MRI systems. For example, the integration of the EEG system and the MRI system may include sharing of one or more hardware and/or software resources. For example, in some embodiments, at least a portion of the power and/or control electronics used to acquire EEG data and MRI data may be shared to reduce the footprint of the integrated system for improved portability. Additionally, system 500 includes several processing components configured to perform different processing functions including EEG processing, MRI reconstruction, and EEG source localization. In some embodiments, some or all of these processing functions may be implemented by one or more shared processors programmed to perform the functions. In some embodiments, some or all components of the integrated functional imaging system are disposed on a cart to improve portability of the system.

[0083] In some embodiments, some or all of the components in EEG system 300 shown in FIG. 3 may be integrated with console 530. For example, the EEG processing signal chain may be implemented using components of console 530 rather than being provided separately as shown in FIG. 5. Accordingly, some embodiments are directed to an integrated system comprising at least one component configured to perform both MRI processing and EEG processing to provide a compact functional neuroimaging system with reduced power requirements. For example, signal input and/or outputs (I/O) for both MRI and EEG may be provided by and implemented on a single "board" and integrated with a single system for performing EEG-based imaging. In this context, a control board may be implemented with a controller and I/O capabilities to control operation of both MR and EEG devices, or certain portions thereof in the MR and EEG signal chain.

[0084] The above-described functional imaging system combines EEG and low-field MRI imaging modalities to provide spatiotemporal functional neuroimaging data that can be used to diagnose and monitor any of a large number of neurological disease states. The inventors have recognized

and appreciated that the portability of some low-field MRI systems enables the integration of any of a number of physiological measurement systems with low-field MRI to produce a functional imaging system. For example, in some embodiments, a low-field MRI device is integrated with one or more electrophysiological measurement systems including, but not limited to, an EEG system, an electromyography (EMG) system, an electrooculography (EOG) system, and an electrocardiography (ECG) system. In some embodiments, a low-field MRI system is integrated with an optical imaging system. In yet other embodiments, a low-field MRI system is integrated with an ultrasound imaging system. In some or all embodiments comprising a low-field MRI system integrated with a physiological measurement system, the low-field MRI system and the physiological measurement system may be configured to simultaneously acquire MRI data and physiological data. According to some embodiments, MR data and electrophysiological data is acquired serially, either by interleaving the acquisition or performing acquisition of MR data followed by acquisition of EEG data or vice versa.

[0085] When MR data is acquired simultaneously with electrophysiological data, operation of the MR device can produce artifacts in acquired electrophysiological data. For example, gradient coil switching and/or radio frequency (RF) switching can cause spikes to appear in the electrophysiological data (e.g., EEG data). Such artifacts may be removed or suppressed using software and/or the MR pulse sequence can be used to assist in removing artifacts. For example, because the pulse sequence defines the timing of gradient and RF switching, this information can be used to identify and remove artifacts in acquired electrophysiological data. Noise or artifacts resulting from operation of the MR device can be removed in other ways, as the aspects are not limited in this respect.

[0086] The functional neuroimaging system described above may also be used in combination with Overhauser-enhanced MRI (OMRI) to obtain information on free radicals, either endogenous or via contrast agents introduced to the patient being imaged. The data from the different modalities (e.g., EEG, MRI and/or OMRI) may be combined, registered or otherwise utilized to provide rich data on a patient's brain for use in a variety of applications including disease characterization, diagnostics, behavior maps, trauma assessment, visualization of brain activity (e.g., in repose or resting, in response to stimuli, cognitive activity, drugs, etc.). Such an integrated neuroimaging system can provide multi-modal data that is otherwise unavailable.

[0087] FIGS. 6A-C illustrate brain imaging helmets for low-field MRI configured that can be used in conjunction with other electrophysiological measurements such as EEG to provide an integrated neuroimaging device. The helmets may include a B_0 magnet in a solenoid geometry about the surface of the helmet to produce a B_0 field in an axially direction through the head (i.e., from the top of the head to the bottom or vice versa.) The helmets may further have incorporated therein a gradient system having one or more gradient coils and an Rx/Tx coil array from excitation and detection, or one or more of the magnetics component may be provided separately.

[0088] In the embodiment illustrated in FIG. 6A, the magnetics are arranged for full clearance of the patient's face and is therefore the most open of the three configurations. In the embodiment illustrated in FIG. 6B, one or more magnetics components necessitate partial blockage of the face (e.g.,

multi-channel or single-channel RF coil elements and/or B_0 windings may need to be provided in this area to meet particular design requirements. In the embodiment illustrated in FIG. 6C, openings remain around the patient's eyes to minimize claustrophobic effects, but one or more magnetics components are housed within the helmet in the front portion over the patient's mouth area. The neuroimaging helmets provide relative freedom of the user's hands, allowing for neuroimaging to be conducted while a user performs one or more desired tasks, manipulates objects and/or makes selections on a computer screen via mouse or touch screen, opening up a wealth of new possibilities with respect to functional brain imaging.

[0089] As discussed above, the inventors have recognized that low-field MRI can be utilized to assist in therapeutic procedures (e.g., one or more surgical procedures), for example, procedures that benefit from image guidance techniques. As used herein, therapy refers to any procedure used to perform a treatment. Therapeutic procedures include, but are not limited to, high intensity focused ultrasound (HIFU), optical procedures such as laser therapies, x-ray therapy procedures, transcranial magnetic stimulation (TMS), etc. Therapeutic procedures typically involve a corresponding therapeutic device, for example, an ultrasound device, a laser device, an x-ray device, a TMS coil, etc. Low-field MR facilitates the use of one or more therapeutic devices in conjunction with MR.

[0090] As discussed above, the significantly lower field strengths of low-field MRI allow for open geometries that facilitate access to the patient by a surgeon performing a procedure. For example, the bi-planar geometry illustrated in FIG. 1 allows for a patient to be placed between the bi-planar coils for imaging and permits access to the patient by a clinician. Any of the low-field MRI systems described in the '652 application may be used in this respect. For example, FIGS. 7, 8A, 8B, 9A and 9B illustrate exemplary bi-planar configurations that may be suitable for use in conjunction with one or more surgical procedures, as discussed in further detail below.

[0091] In addition, the low field strengths involved in low-field MR allow for a wider variety of instrumentation to be used in proximity to the MR equipment. For example, any of various therapeutic devices that cannot be operated in proximity to a high-field MRI system may be operated in conjunction with a low-field MR device. Techniques for suppressing noise in the environment of a low-field MR device described in U.S. application Ser. No. 14/845,949 ('949 application), titled "Noise Suppression Methods and Apparatus," filed on Sep. 4, 2015, which is herein incorporated by reference in its entirety, can be utilized to facilitate the use of one or more therapeutic devices in conjunction with a low-field MR device. In particular, noise or disturbances caused by one or more therapeutic devices can be detected, characterized and suppressed using the techniques described therein.

[0092] FIG. 7 illustrates system 700 showing a patient 785 seated within the field of view of bi-planar magnets 715A and 715B comprising magnetics components configured to perform low-field MRI with an outer covering or housing, which may further comprise other components such as internal shielding, electrical connections, power and control electronics, etc. and which may generally provide a measure of environmental protection for low-field magnetics components (e.g., B_0 magnet, gradient coils, transmit/receive coils, etc.).

[0093] FIGS. 8A and 8B show a system 800 having a reclining configuration in which the magnetics components 810A and 810B are arranged within a frame comprising a seating portion 835 adjustably oriented at an angle to accommodate a patient being placed between the magnetics components in a reclined position. The reclining portion of the system may be adjustable to facilitate a desired positioning of the patient between the magnetics components so that the desired portion of the patient is located within the field of view of the magnet. Additionally or alternatively, the magnetics components may be adjustable within enclosure 815 to provide additional flexibility in positioning the magnetics relative to the patient. Magnetics components 810A and 810B may be connected via one or more suitable cables to power electronics, which may be mounted on a rack or housed with another suitable transportable structure to facilitate the portability of the MRI system. These example systems are generally open at facilitate more convenient access to the patient by a surgeon performing a procedure.

[0094] FIGS. 9A-9B illustrate a portable or cartable low-field MRI system 900 suitable for use in performing techniques described herein, in accordance with some embodiments. System 900 may include magnetic and power components, and potentially other components (e.g., thermal management, console, etc.), arranged together on a single generally transportable and transformable structure. System 900 may be designed to have at least two configurations; a configuration adapted for transport and storage, and a configuration adapted for operation. FIG. 9A shows system 900 when secured for transport and/or storage and FIG. 9B shows system 900 when transformed for operation. System 900 comprises a portion 990A that can be slid into and retracted from a portion 990B when transforming the system from its transport configuration to its operation configuration, as indicated by the arrows shown in FIG. 9B. Portion 990A may house power electronics, console (which may comprise an interface device such as a touch panel display) and thermal management. Portion 990A may also include other components used to operate system 900 as needed. The transportable system includes castors or wheels 972 to allow the system to be rolled to a desired location and a brake 974 (see FIG. 9B) to fix the system when the desired location is reached.

[0095] Portion 990B comprises magnetics components of low-field MRI system 900. When transformed to the configuration adapted for operating the system to perform MRI (as shown in FIG. 9B), supporting surfaces of portions 990A and 990B provide a surface on which the patient can lie. A slideable bed or surface 984 may be provided to facilitate sliding the patient into position so that a portion of the patient to be imaged is within the field of view of the low-field MRI magnetics components. System 900 provides for a portable compact configuration of a low-field MRI system that facilitates access to the device in circumstances where it conventionally is not available.

[0096] FIGS. 9A-9B illustrate an example of a convertible low field MRI system that utilizes a bi-planar magnet forming an imaging region between housings 986A and 986B. Housings 986A and 986B house magnetics components for the convertible system 900. According to some embodiments, the magnetics components may be produced, manufactured and arranged using exclusively laminate techniques, exclusively traditional techniques, or using a combination of both (e.g., using hybrid techniques). The convertible low-field MRI system 900 allows the system to be brought to the patient to

facilitate operation in a wide variety of circumstances. As discussed above, due at least in part to the low-field strengths, one or more electrophysiological sensors may be coupled to the patient to obtain electrophysiological data and one or more controllers may be disposed within convertible system 900 to control data acquisition. For example, the patient may wear an EEG cap or head unit having a plurality of electrodes configured to obtain EEG data from the patient while positioned within the field of view of system 900. A controller (or multiple controllers) of system 900 may be configured to obtain MR data and electrophysiological data and utilize the MR data to provide spatiotemporal electrophysiological data, for example, one or more functional spatiotemporal EEG, EKG, EMG, EOG images, etc.

[0097] The inventors have appreciated that an exemplary therapeutic procedure that may benefit from low-field MRI is high intensity focused ultrasound (HIFU), which involves applying high-intensity focused ultrasound energy to specific locations to ablate tissue (i.e., by heating and destroying target tissue such as a tumor). MRI has been used to guide this procedure to ensure that the HIFU energy is being applied to diseased and not healthy tissue to reduce or mitigate collateral tissue damage to the extent possible. As discussed above, using low-field MRI instead of high-field MRI allows open configurations to be used to provide significantly improved access to the patient as well as to allow for a greater variety of tools and instruments to be utilized during the procedure due to the significantly lower field strengths.

[0098] The inventors have further appreciated that low-field MRI may have additional benefits in assisting and improving a HIFU procedure. For example, the relaxation time T1 in MR is dependent on temperature and can be used to monitor the temperature at the application site and proximate to the site of tissue ablation. By analyzing T1 times, an alert may be generated to warn a surgeon when temperatures are reaching unacceptable levels in the area of healthy tissue and temporarily suspend application of the ultrasound or adjust the location of the application to avoid damaging or destroying healthy tissue. Low-field MRI may be used to guide other surgical or therapeutic operations, including tissue ablation using other techniques such as focused radio frequency (RF) techniques, lasers or other optic techniques, x-ray techniques, etc., or in other therapies such as to facilitate placement of a TMS coil to perform a desired TMS treatment.

[0099] The inventors have further appreciated that Overhauser-enhanced MRI (OMRI) can be utilized at low-field strengths to detect free-radicals, which can be used as a guide to locating and ablating tissue having high concentrations of free radicals such as tumors. OMRI may also be used as an early detection mechanism to locate areas of high free radical concentrations, which may be indicative of angiogenic, metabolic or other tumor processes that can be detected at an early stage. Free radical detection via OMRI may also provide a measure of the efficacy of HIFU treatment as the tissue ablation processes destroys tissue and generates free radicals. Furthermore, contrast agents may be administered to improve the contrast of low-field MRI. The contrast agents may include drugs or compounds that begin the processes of tissue destruction and/or that promote free radical production. Following administration of a contrast agent, the site of tissue ablation may be located via OMRI or using low-field MRI

without Overhauser-enhancement in one or more images to assist the surgeon in applying HIFU to the desired site of tissue ablation.

[0100] As discussed above, EEG-based neuroimaging may be deployed in control systems to control, at least in part, any number of systems or machines. For example, in the medical field, EEG functional data may be obtained and processed to understand a person's intent and/or otherwise characterize the individual's thoughts to control prosthetics, operate a wheel chair, etc. In the industrial fields, such neuroimaging control may be used to operate a vehicle or a portion thereof (e.g., an automobile, aircraft, military vehicle, etc.) and/or control a robotic "outfit" to allow human wearers to engage in activities that would otherwise be impossible (e.g., lifting heavy objects, transporting dangerous materials, etc.). Operation of many vehicles (and other machinery) already requires the operator to wear a helmet, and an integrated EEG/low-field MRI device may be incorporated into existing helmets or new helmets may be designed to include such an integrated neuroimaging device. In the business context, neuroimaging control may be used to operate a computer or to assist in using other electronic devices. Indeed, functional neuroimaging can be the basis for a variety of man-machine interfaces to facilitate control or operation of a machine or system. Functional neuroimaging may also be used as a monitoring mechanism as a check on a human operator, for example, to detect and alert a human operator (e.g., a driver) when it is detected that the operator has fallen asleep, or to otherwise detect and mitigate when an operator has entered other deleterious or unsafe brain states that put the safety of the operator or others at risk.

[0101] Having thus described several aspects and embodiments of the technology set forth in the disclosure, it is to be appreciated that various alterations, modifications, and improvements will readily occur to those skilled in the art. Such alterations, modifications, and improvements are intended to be within the spirit and scope of the technology described herein. For example, those of ordinary skill in the art will readily envision a variety of other means and/or structures for performing the function and/or obtaining the results and/or one or more of the advantages described herein, and each of such variations and/or modifications is deemed to be within the scope of the embodiments described herein. Those skilled in the art will recognize, or be able to ascertain using no more than routine experimentation, many equivalents to the specific embodiments described herein. It is, therefore, to be understood that the foregoing embodiments are presented by way of example only and that, within the scope of the appended claims and equivalents thereto, inventive embodiments may be practiced otherwise than as specifically described. In addition, any combination of two or more features, systems, articles, materials, kits, and/or methods described herein, if such features, systems, articles, materials, kits, and/or methods are not mutually inconsistent, is included within the scope of the present disclosure.

[0102] The above-described embodiments can be implemented in any of numerous ways. One or more aspects and embodiments of the present disclosure involving the performance of processes or methods may utilize program instructions executable by a device (e.g., a computer, a processor, a controller or other device) to perform, or control performance of, the processes or methods. In this respect, various inventive concepts may be embodied as a computer readable storage medium (or multiple computer readable storage media) (e.g.,

a computer memory, one or more floppy discs, compact discs, optical discs, magnetic tapes, flash memories, circuit configurations in Field Programmable Gate Arrays or other semiconductor devices, or other tangible computer storage medium) encoded with one or more programs that, when executed on one or more computers or other processors, perform methods that implement one or more of the various embodiments described above. The computer readable medium or media can be transportable, such that the program or programs stored thereon can be loaded onto one or more different computers or other processors to implement various ones of the aspects described above. In some embodiments, computer readable media may be non-transitory media.

[0103] The terms "program" or "software" are used herein in a generic sense to refer to any type of computer code or set of computer-executable instructions that can be employed to program a computer or other processor to implement various aspects as described above. Additionally, it should be appreciated that according to one aspect, one or more computer programs that when executed perform methods of the present disclosure need not reside on a single computer or processor, but may be distributed in a modular fashion among a number of different computers or processors to implement various aspects of the present disclosure.

[0104] Computer-executable instructions may be in many forms, such as program modules, executed by one or more computers or other devices. Generally, program modules include routines, programs, objects, components, data structures, etc. that perform particular tasks or implement particular abstract data types. Typically the functionality of the program modules may be combined or distributed as desired in various embodiments.

[0105] Also, data structures may be stored in computer-readable media in any suitable form. For simplicity of illustration, data structures may be shown to have fields that are related through location in the data structure. Such relationships may likewise be achieved by assigning storage for the fields with locations in a computer-readable medium that convey relationship between the fields. However, any suitable mechanism may be used to establish a relationship between information in fields of a data structure, including through the use of pointers, tags or other mechanisms that establish relationship between data elements.

[0106] When implemented in software, the software code can be executed on any suitable processor or collection of processors, whether provided in a single computer or distributed among multiple computers.

[0107] Further, it should be appreciated that a computer may be embodied in any of a number of forms, such as a rack-mounted computer, a desktop computer, a laptop computer, or a tablet computer, as non-limiting examples. Additionally, a computer may be embedded in a device not generally regarded as a computer but with suitable processing capabilities, including a Personal Digital Assistant (PDA), a smartphone or any other suitable portable or fixed electronic device.

[0108] Also, a computer may have one or more input and output devices. These devices can be used, among other things, to present a user interface. Examples of output devices that can be used to provide a user interface include printers or display screens for visual presentation of output and speakers or other sound generating devices for audible presentation of output. Examples of input devices that can be used for a user interface include keyboards, and pointing devices, such as

mice, touch pads, and digitizing tablets. As another example, a computer may receive input information through speech recognition or in other audible formats.

[0109] Such computers may be interconnected by one or more networks in any suitable form, including a local area network or a wide area network, such as an enterprise network, and intelligent network (IN) or the Internet. Such networks may be based on any suitable technology and may operate according to any suitable protocol and may include wireless networks, wired networks or fiber optic networks.

[0110] Also, as described, some aspects may be embodied as one or more methods. The acts performed as part of the method may be ordered in any suitable way. Accordingly, embodiments may be constructed in which acts are performed in an order different than illustrated, which may include performing some acts simultaneously, even though shown as sequential acts in illustrative embodiments.

[0111] All definitions, as defined and used herein, should be understood to control over dictionary definitions, definitions in documents incorporated by reference, and/or ordinary meanings of the defined terms.

[0112] The indefinite articles “a” and “an,” as used herein in the specification and in the claims, unless clearly indicated to the contrary, should be understood to mean “at least one.”

[0113] The phrase “and/or,” as used herein in the specification and in the claims, should be understood to mean “either or both” of the elements so conjoined, i.e., elements that are conjunctively present in some cases and disjunctively present in other cases. Multiple elements listed with “and/or” should be construed in the same fashion, i.e., “one or more” of the elements so conjoined. Other elements may optionally be present other than the elements specifically identified by the “and/or” clause, whether related or unrelated to those elements specifically identified. Thus, as a non-limiting example, a reference to “A and/or B”, when used in conjunction with open-ended language such as “comprising” can refer, in one embodiment, to A only (optionally including elements other than B); in another embodiment, to B only (optionally including elements other than A); in yet another embodiment, to both A and B (optionally including other elements); etc.

[0114] As used herein in the specification and in the claims, the phrase “at least one,” in reference to a list of one or more elements, should be understood to mean at least one element selected from any one or more of the elements in the list of elements, but not necessarily including at least one of each and every element specifically listed within the list of elements and not excluding any combinations of elements in the list of elements. This definition also allows that elements may optionally be present other than the elements specifically identified within the list of elements to which the phrase “at least one” refers, whether related or unrelated to those elements specifically identified. Thus, as a non-limiting example, “at least one of A and B” (or, equivalently, “at least one of A or B,” or, equivalently “at least one of A and/or B”) can refer, in one embodiment, to at least one, optionally including more than one, A, with no B present (and optionally including elements other than B); in another embodiment, to at least one, optionally including more than one, B, with no A present (and optionally including elements other than A); in yet another embodiment, to at least one, optionally including more than one, A, and at least one, optionally including more than one, B (and optionally including other elements); etc.

[0115] Also, the phraseology and terminology used herein is for the purpose of description and should not be regarded as limiting. The use of “including,” “comprising,” or “having,” “containing,” “involving,” and variations thereof herein, is meant to encompass the items listed thereafter and equivalents thereof as well as additional items.

[0116] In the claims, as well as in the specification above, all transitional phrases such as “comprising,” “including,” “carrying,” “having,” “containing,” “involving,” “holding,” “composed of,” and the like are to be understood to be open-ended, i.e., to mean including but not limited to. Only the transitional phrases “consisting of” and “consisting essentially of” shall be closed or semi-closed transitional phrases, respectively.

1. A system, comprising:

a low-field magnetic resonance (MR) device;

at least one electrophysiological device; and

at least one controller configured to operate the low-field MR device to obtain MR data and to operate the at least one electrophysiological device to obtain electrophysiological data.

2. The system of claim 1, wherein the at least one electrophysiological device comprises an electroencephalography (EEG) device comprising a plurality of electrodes configured to obtain EEG data when the patient is within the field of view of the low-field magnetic resonance device, and wherein the at least one controller is configured to operate the EEG device to obtain the EEG data.

3. The system of claim 1, wherein the at least one electrophysiological device comprises at least one of an electromyography (EMG) device comprising at least one sensor configured to obtain EMG data, an electrooculography (EOG) device comprising at least one sensor configured to obtain EOG data, and an electrocardiography (ECG) device comprising at least one sensor configured to obtain ECG data.

4-9. (canceled)

10. The system of claim 2, wherein the at least one controller comprises at least one processor configured to use the MR data to perform source localization of the EEG data to generate at least one EEG image.

11. The system of claim 10, wherein the at least one processor is configured to generate at least one three-dimensional (3D) EEG image from the EEG data using the MR data.

12. The system of claim 10, wherein the at least one controller is configured to operate the EEG device to obtain EEG data over time and wherein the at least one processor is configured to generate at least one spatiotemporal EEG image.

13. (canceled)

14. The system of claim 2, wherein the EEG device comprises at least one marker configured to be placed on the patient, and wherein the at least one controller is configured to determine a spatial position of the at least one marker from the MR data for use in generating the at least one EEG image.

15-21. (canceled)

22. The system of claim 1, wherein the low-field magnetic resonance device comprises magnetic components configured to produce a B0 field having a strength equal to or less than approximately 0.2 T and greater than or equal to approximately 0.1 T.

23. The system of claim 1, wherein the low-field magnetic resonance device comprises magnetic components config-

ured to produce a B0 field having a strength equal to or less than approximately 0.1 T and greater than or equal to approximately 50 mT.

24. The system of claim **1**, wherein the low-field magnetic resonance device comprises magnetics components configured to produce a B0 field having a strength equal to or less than approximately 50 mT and greater than or equal to approximately 20 mT.

25. The system of claim **1**, wherein the low-field magnetic resonance device comprises magnetics components configured to produce a B0 field having a strength equal to or less than approximately 20 mT and greater than or equal to approximately 10 mT.

26. The system of claim **2**, wherein the at least one controller is configured to adapt at least one characteristic of the low-field magnetic resonance device based, at least in part, on the EEG device.

27. The system of claim **26**, wherein the at least one controller is configured to modify a B0 field produced by the low-field magnetic resonance device based, at least in part, on the EEG device.

28. (canceled)

29. The system of claim **26**, wherein the at least one controller is configured to adapt at least one characteristic of the low-field magnetic resonance device based, at least in part, on the EEG data.

30. (canceled)

31. The system of claim **29**, wherein the at least one controller is configured to change at least one of field of view, signal-to-noise ratio and resolution of an MR acquisition process based on the EEG data.

32-37. (canceled)

38. The system of claim **6**, wherein the at least one processor is configured to generate at least one MR image from the MR data, and wherein the at least one controller is configured to present at least one electrophysiological image in conjunction with at least one MR image.

39-40. (canceled)

41. The system of claim **1**, further comprising a transportable apparatus on which the low-field magnetic resonance device and the at least one electrophysiological device are disposed that allows the system to be transported and operated in different locations.

42. The system of claim **1**, wherein the transportable apparatus is configurable in a configuration for transporting the system and a configuration for operating the system.

43. The system of claim **1**, wherein the low-field magnetic resonance device is configured to generate an MR image having an in-plane resolution of at least three millimeters and up to and including approximately one millimeter.

44. The system of claim **1**, wherein the low-field magnetic resonance device is configured to generate an MR image having a resolution up to and including approximately three millimeters isotropic.

45. The system of claim **2**, wherein the EEG device is operably connected to the low-field magnetic resonance device by at least one communications connection.

46. The system of claim **2**, wherein at least a portion of the EEG device is integrated with the low-field magnetic resonance device.

47. The system of claim **46**, wherein at least a portion of a EEG signal processing chain is integrated with processing components of the low-field magnetic resonance device.

48. The system of claim **47**, wherein at least one component of the system performs both EEG signal processing and MR signal processing.

49. The system of claim **1**, wherein the controller is configured to operate the low-field MR device and the electrophysiological device to obtain the MR data and the electrophysiological data while a patient remains in a field of view of the low-field MR device.

50. (canceled)

51. The system of claim **1**, wherein the at least one controller is configured to operate the low-field magnetic resonance device and the at least one electrophysiological device simultaneously.

52-60. (canceled)

61. The system of claim **1**, further comprising at least one therapeutic device configured to deliver therapy to the patient within the field of view of the low-field magnetic resonance device, wherein the therapy is guided, at least in part, using the MR data.

62. A method of operating a system comprising a low-field magnetic resonance (MR) device and at least one electrophysiological device, the method comprising:

while a patient is positioned within a field of view of the low-field MR device:

operating the low-field magnetic resonance device to obtain MR data; and

operating the at one electrophysiological device to obtain electrophysiological data.

63. The method of claim **62**, further comprising using the MR data to generate at least one electrophysiological image from the electrophysiological data.

64. At least one computer readable medium having instruction encoded thereon that, when executed by at least one processor, cause a method of operating a system comprising a low-field magnetic resonance (MR) device and at least one electrophysiological device to be performed, the method comprising:

while a patient is positioned within a field of view of the low-field magnetic resonance device:

causing operation of the low-field MR device to obtain MR data; and

causing operation of the at one electrophysiological device to obtain electrophysiological data.

65. The at least one computer readable medium of claim **64**, further comprising generating at least one electrophysiological image from the electrophysiological data using the MR data.

66-76. (canceled)

* * * * *

专利名称(译)	低场磁共振方法和装置		
公开(公告)号	US20160128592A1	公开(公告)日	2016-05-12
申请号	US14/938333	申请日	2015-11-11
申请(专利权)人(译)	超精细研究, INC.		
当前申请(专利权)人(译)	超精细研究, INC.		
[标]发明人	ROSEN MATTHEW SCOT CHARVAT GREGORY L SACOLICK LAURA SARRACANIE MATHIEU ROTHBERG JONATHAN M RALSTON TYLER S		
发明人	ROSEN, MATTHEW SCOT CHARVAT, GREGORY L. SACOLICK, LAURA SARRACANIE, MATHIEU ROTHBERG, JONATHAN M. RALSTON, TYLER S.		
IPC分类号	A61B5/04 A61B5/0488 G01R33/36 A61B5/0402 A61B5/00 G01R33/48 A61B5/0476 A61B5/0496		
CPC分类号	A61B5/04012 A61B5/0476 A61B5/0488 A61B5/0496 A61B2576/00 A61B5/7425 G01R33/4806 G01R33/3614 A61B2019/5454 A61B5/0402 A61B5/055 A61B2090/3954 G01R33/3806 G01R33/381 G01R33/445 G01R33/4808 G16H30/40		
优先权	62/078383 2014-11-11 US		
外部链接	Espacenet USPTO		

摘要(译)

根据一些方面, 提供了一种系统, 包括低场磁共振 (MR) 设备, 至少一个电生理设备, 以及至少一个控制器, 其配置成操作低场MR设备以获得MR数据并至少操作一种获得电生理学数据的电生理学装置。

