



(19) **United States**  
(12) **Patent Application Publication**  
**SELVARAJ et al.**

(10) **Pub. No.: US 2015/0164411 A1**  
(43) **Pub. Date: Jun. 18, 2015**

(54) **AUTOMATED PREDICTION OF APNEA-HYPOPNEA INDEX USING WEARABLE DEVICES**

*A61B 5/0456* (2006.01)  
*A61B 5/0205* (2006.01)  
*A61B 5/0402* (2006.01)

(71) Applicant: **Vital Connect, Inc.**, Campbell, CA (US)

(52) **U.S. Cl.**  
CPC ..... *A61B 5/4818* (2013.01); *A61B 5/0205* (2013.01); *A61B 5/0402* (2013.01); *A61B 5/1116* (2013.01); *A61B 5/0456* (2013.01); *A61B 5/1121* (2013.01); *A61B 5/04012* (2013.01); *A61B 5/6801* (2013.01); *A61B 5/0006* (2013.01); *A61B 5/7203* (2013.01)

(72) Inventors: **Nandakumar SELVARAJ**, Santa Clara, CA (US); **Ravi NARASIMHAN**, Sunnyvale, CA (US)

(73) Assignee: **Vital Connect, Inc.**, Campbell, CA (US)

(21) Appl. No.: **14/274,313**

(57) **ABSTRACT**

(22) Filed: **May 9, 2014**

A method and system for determining Apnea-Hypopnea Index (AHI) values are disclosed. The method comprises determining at least one sensor stream using at least one detected physiological signal, and processing the at least one sensor stream to automatically determine the AHI values. The system includes a sensor to detect at least one physiological signal, a processor coupled to the sensor, and a memory device coupled to the processor, wherein the memory device includes an application that, when executed by the processor, causes the processor to determine at least one sensor stream using at least one detected physiological signal and to process the at least one sensor stream to automatically determine the AHI values.

**Related U.S. Application Data**

(60) Provisional application No. 61/916,024, filed on Dec. 13, 2013.

**Publication Classification**

(51) **Int. Cl.**  
*A61B 5/00* (2006.01)  
*A61B 5/04* (2006.01)  
*A61B 5/11* (2006.01)

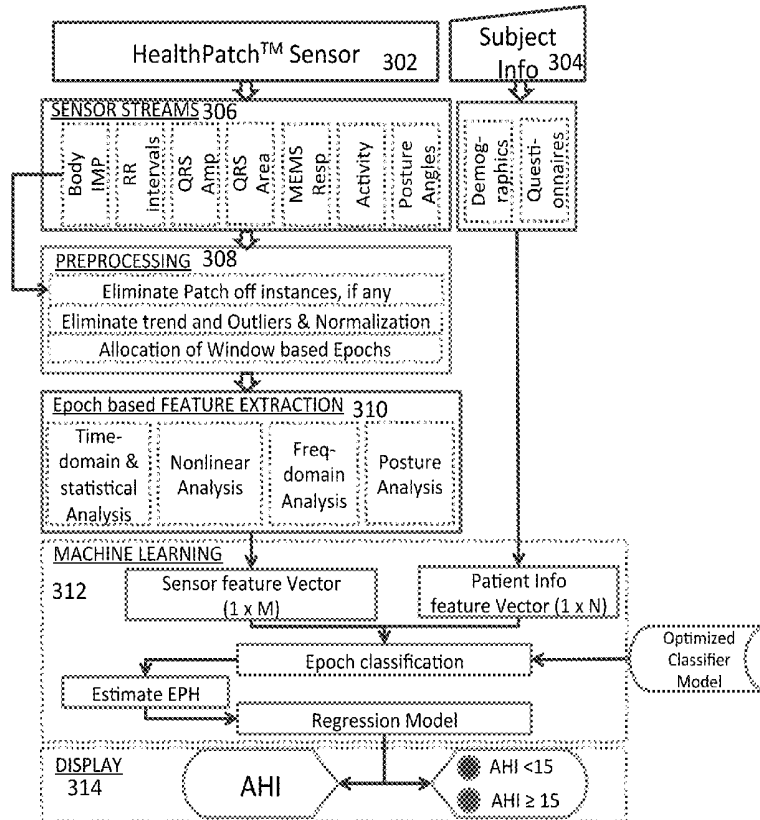

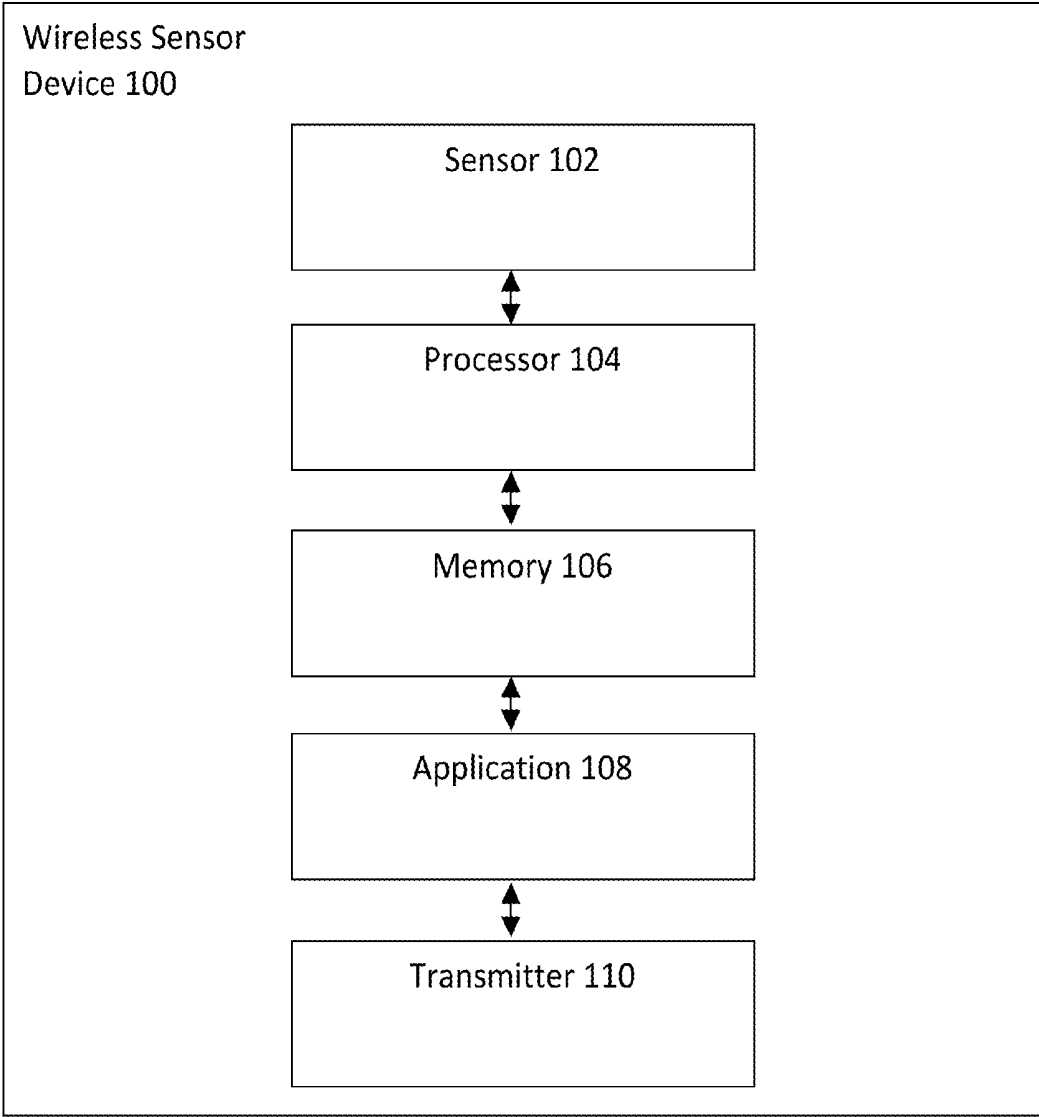

Figure 1

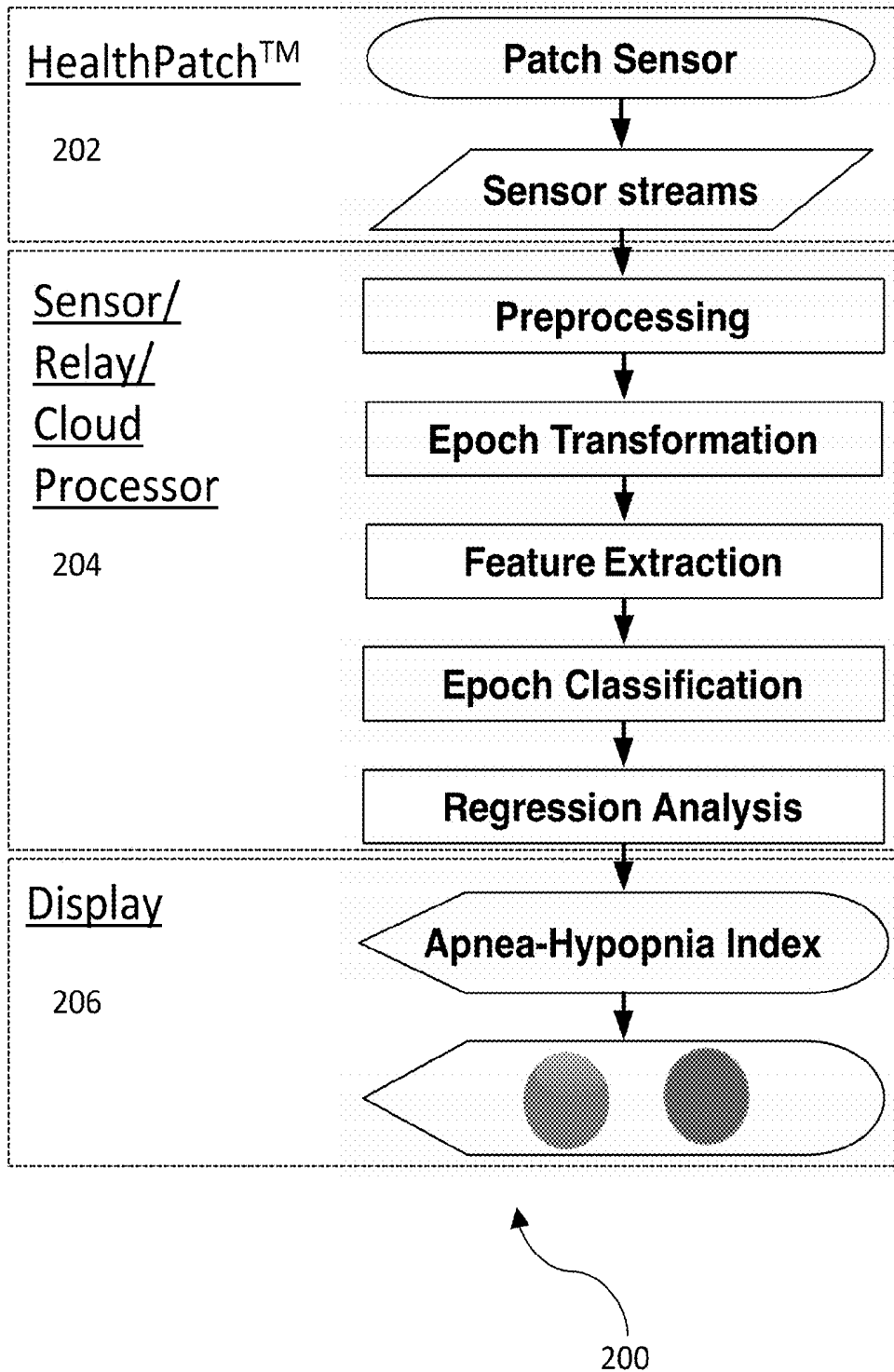

Figure 2

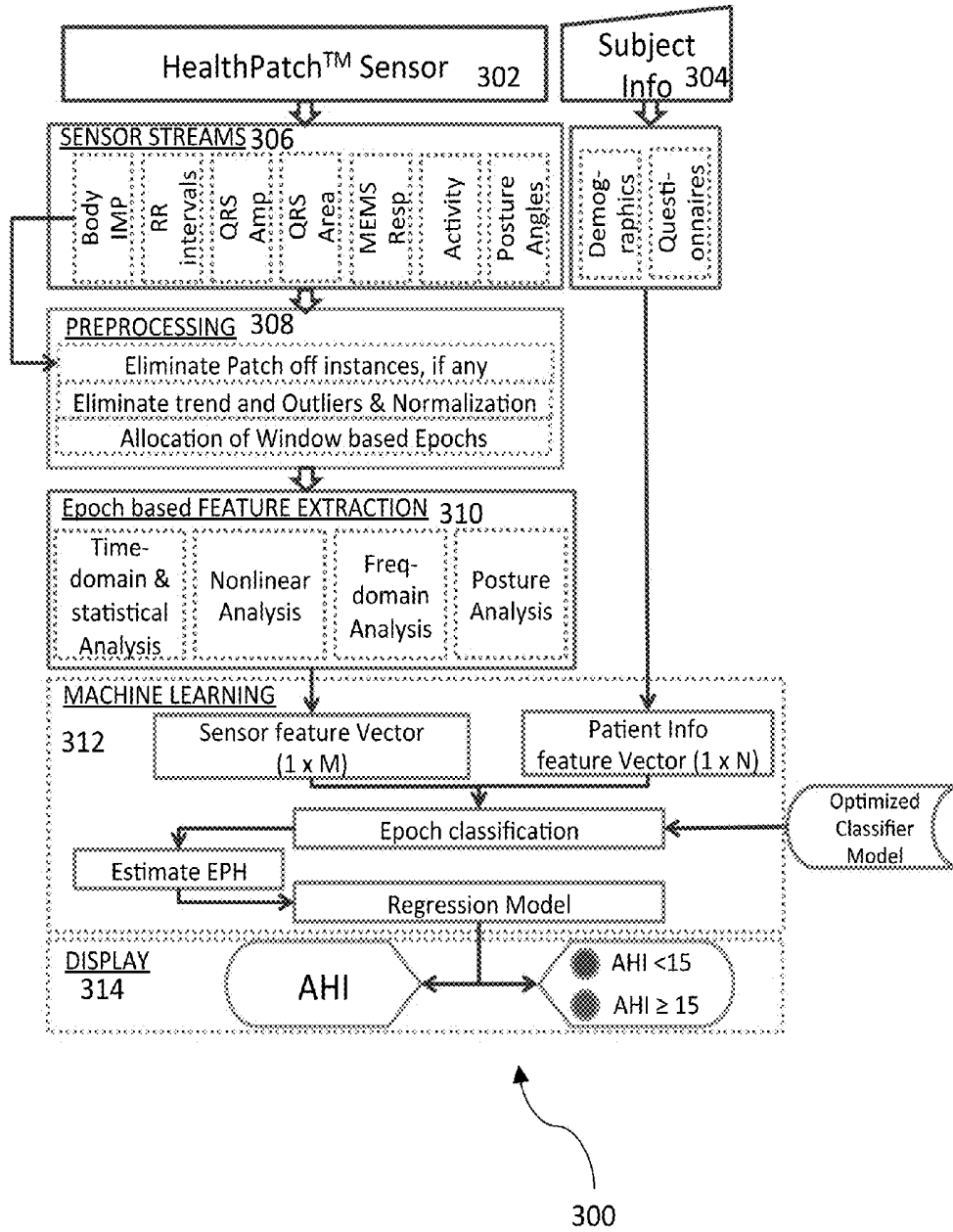

Figure 3

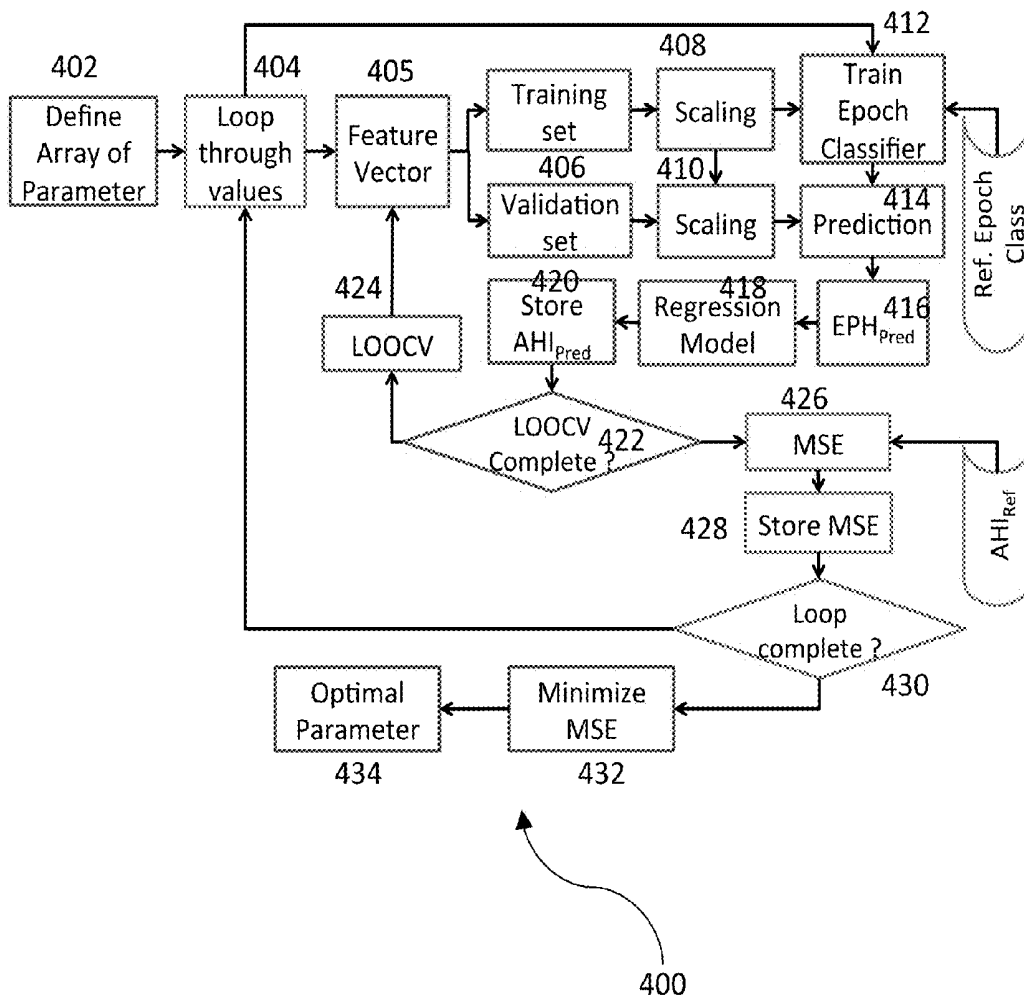
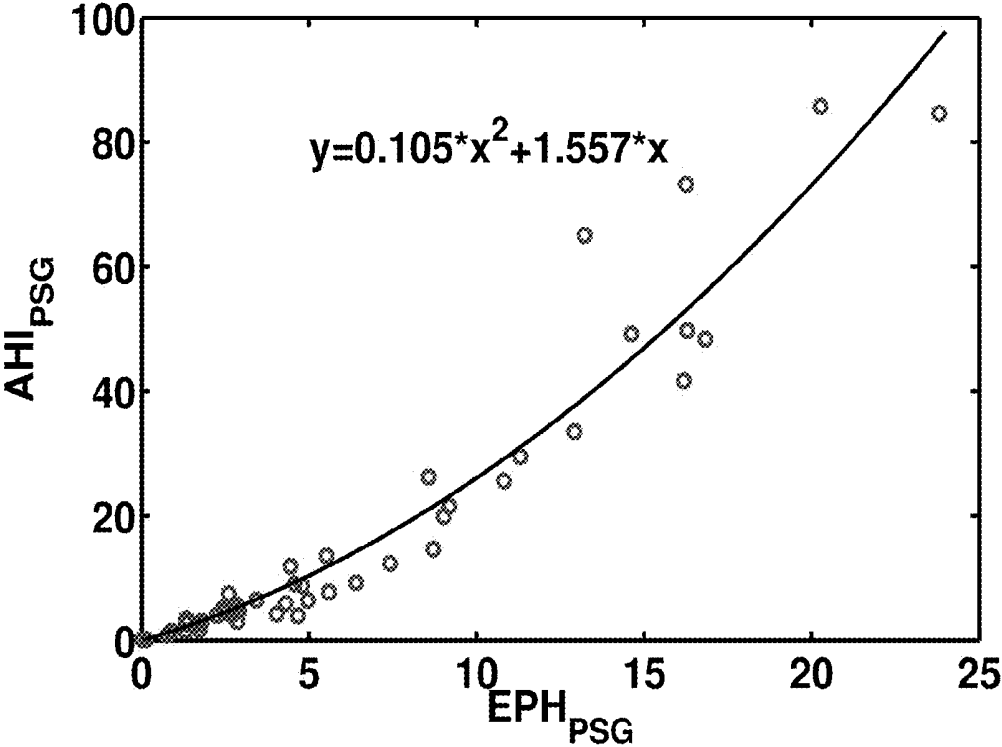
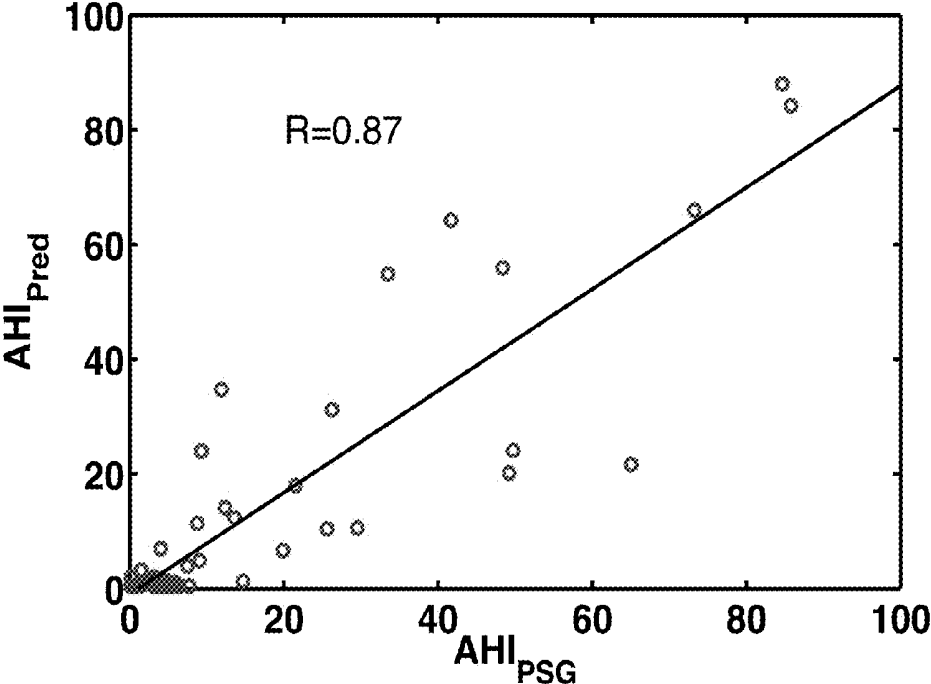

Figure 4



500

Figure 5



600

Figure 6

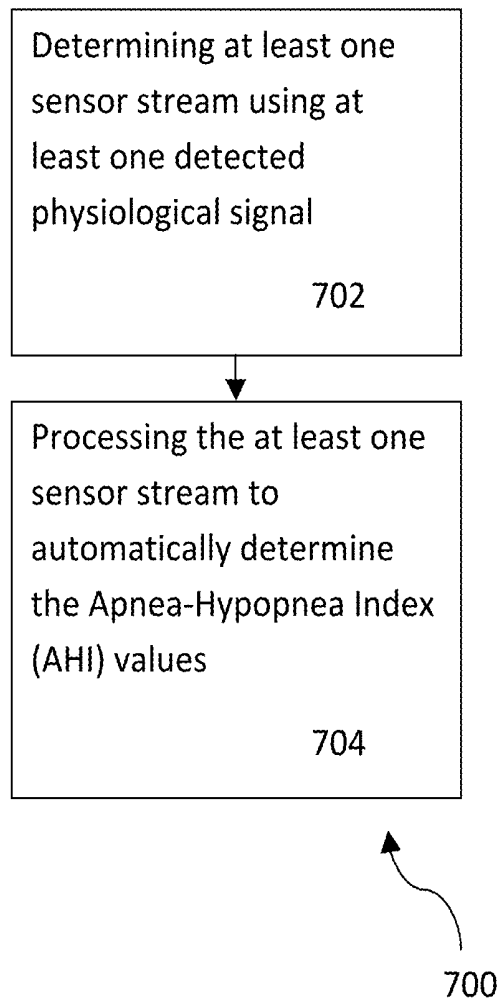

Figure 7

## AUTOMATED PREDICTION OF APNEA-HYPOPNEA INDEX USING WEARABLE DEVICES

### CROSS-REFERENCE TO RELATED APPLICATION

**[0001]** This application claims benefit under 35 USC 119 (e) of U.S. Provisional Patent Application No. 61/916,024, filed on Dec. 13, 2013, entitled "SLEEP APNEA SCREENING AND AUTOMATED PREDICTION OF APNEA-HYPOPNEA INDEX USING A WEARABLE PATCH SENSOR," which is incorporated herein by reference in its entirety.

### FIELD OF THE INVENTION

**[0002]** The present invention relates to wearable devices, and more particularly, to automatically predicting the Apnea-Hypopnea Index (AHI) using wearable devices.

### BACKGROUND

**[0003]** The accurate measurement of sleep related diseases such as sleep apnea is important to managing the overall health of a person. Sleep Apnea Syndrome (SAS) is a major sleep disorder that causes recurrent episodes of complete (apnea) or partial (hypopnea) blockage of the upper airway during sleep. One of the metrics that quantify the severity of SAS is the Apnea-Hypopnea Index (AHI), which is the number of apnea and hypopnea events per hour averaged over the duration of sleep. Accurate SAS screening and AHI determination is important because there are adverse health consequences of SAS, including daytime hypersomnolence, neurocognitive dysfunction, cardiovascular disease, metabolic dysfunction and respiratory failure.

**[0004]** Conventional SAS screening and AHI prediction is done via sleep laboratory testing facilities using cumbersome polysomnography (PSG) tests. The PSG test conducted at a sleep center facility requires an abundance of sensors and interferes with the person's normal sleep rhythms. The PSG test also involves high operating costs, in part because of the dedicated equipment, facilities, and personnel required to conduct the test. Additionally, the PSG test is time consuming and often varies based on the subjective interpretation of medical experts.

**[0005]** Therefore, there is a strong need for a solution that overcomes the aforementioned issues. The present invention addresses such a need.

### SUMMARY OF THE INVENTION

**[0006]** A method and system for determining Apnea-Hypopnea Index (AHI) values are disclosed. The method comprises determining at least one sensor stream using at least one detected physiological signal, and processing the at least one sensor stream to automatically determine the AHI values.

**[0007]** The system includes a sensor to detect at least one physiological signal, a processor coupled to the sensor, and a memory device coupled to the processor, wherein the memory device includes an application that, when executed by the processor, causes the processor to determine at least one sensor stream using at least one detected physiological signal and to process the at least one sensor stream to automatically determine the AHI values.

### BRIEF DESCRIPTION OF THE DRAWINGS

**[0008]** The accompanying figures illustrate several embodiments of the invention and, together with the description, serve to explain the principles of the invention. One of ordinary skill in the art readily recognizes that the embodiments illustrated in the figures are merely exemplary, and are not intended to limit the scope of the present invention.

**[0009]** FIG. 1 illustrates a wireless sensor device for automated Apnea-Hypopnea Index (AHI) prediction in accordance with an embodiment.

**[0010]** FIG. 2 illustrates a flow chart of a system for automated Apnea-Hypopnea Index (AHI) prediction in accordance with an embodiment.

**[0011]** FIG. 3 illustrates a more detailed flow chart of a system for automated Apnea-Hypopnea Index (AHI) prediction in accordance with an embodiment.

**[0012]** FIG. 4 illustrates a detailed flow chart of an optimization process of the classifier model in accordance with an embodiment.

**[0013]** FIG. 5 illustrates a graph depicting regression analysis in accordance with an embodiment.

**[0014]** FIG. 6 illustrates a graph depicting the linear correlation between the reference AHI values and predicted AHI values in accordance with an embodiment.

**[0015]** FIG. 7 illustrates a method for automated Apnea-Hypopnea Index (AHI) prediction in accordance with an embodiment.

### DETAILED DESCRIPTION

**[0016]** The present invention relates to wearable devices, and more particularly, to automatically predicting the Apnea-Hypopnea Index (AHI) using wearable devices. The following description is presented to enable one of ordinary skill in the art to make and use the invention and is provided in the context of a patent application and its requirements. Various modifications to the preferred embodiment and the generic principles and features described herein will be readily apparent to those skilled in the art. Thus, the present invention is not intended to be limited to the embodiments shown but is to be accorded the widest scope consistent with the principles and features described herein.

**[0017]** Sleep Apnea Syndrome (SAS) is a chronic sleep disorder that is highly prevalent worldwide. SAS disorder affects health and quality of life, and also leads to serious health consequences such as cardiovascular disease, neurocognitive dysfunction, and respiratory failure. Overnight polysomnography (PSG) tests are commonly performed to screen for SAS disorder and quantify the Apnea-Hypopnea Index (AHI) to assess the severity of the SAS disorder. However, overnight PSG tests performed in a sleep laboratory involves many challenges for SAS screening including affecting normal sleep patterns, causing additional apnea/hypopnea events compared to home environments, high operating costs, requirement of dedicated facilities, equipment and personnel, inadequate availability, and limited repeatability.

**[0018]** In addition to PSG tests, home sleep tests using portable monitors are utilized to screen for SAS disorder but they suffer from high failure rates and limitations including but not limited to complex sensor attachments, obtrusiveness, compliance issues, high operating costs, detachments of sensors during tosses and turns, and returning equipment requirements. Also, a waiting period of at least a couple of weeks after either PSG or home sleep tests is commonly required to

obtain the results, because the algorithms utilized by these tests predict the AHI values based on the sleep technician's visual analysis of events using oxygen saturation and airflow signals.

[0019] A method and system in accordance with the present invention provides a wireless, portable, and wearable sensor device ("wearable device") that is in a patch form factor and that is attached to a user (patient) to automatically and continuously detect a plurality of health related and physiological signals including but not limited to ECG, acceleration signals, and respiratory signals. The wearable device utilizes an embedded electronic module and a plurality of algorithms to process the detected physiological signals and convert them into a plurality of sensor streams.

[0020] In the method and system, the plurality of sensor streams are additionally processed either by the internal processor of the wireless device or by an external device including but not limited to a sensor/relay/cloud processor, a smartphone device, and a server. After the additional processing that comprises any of preprocessing, feature extraction, and machine learning optimization, the method and system automatically and continuously screens the user for SAS disorder and automatically determines the AHI values that describe the severity of the SAS of the user. The method and system output various indications on a display including but not limited to identifications of whether the user has or is at risk for SAS and the AHI values.

[0021] In one embodiment, the method and system utilizes wearable devices to determine AHI values automatically using epoch-based analysis of sensor data detected by the wearable device. The wearable devices are attached to the chest of the user on a location including and not limited to one of the three recommended locations, to detect sensor data of various physiological signals. In one embodiment, the predetermined locations include any of the left midclavicular line over intercostal space (ICS) 2 in a modified lead-II configuration, vertically over the upper sternum, and horizontally on the left midclavicular line over ICS 6. The sensor data is transmitted wirelessly to an external device such as a smart phone for additional analysis to automatically output SAS screening results and predicted AHI values. In another embodiment, the additional analysis is carried out by at least one of the wearable devices and the outputs are displayed by the relay that is connected with the wearable devices or the outputs are displayed by at least one of the wearable devices.

[0022] In this embodiment, the sensor data is from overnight data collection and the data is preprocessed, features are calculated for epochs of predetermined epoch time period (including but not limited to 150 seconds) using analyses of heart rate variability, respiratory signals, posture and movements. In one embodiment, a Linear Support Vector Machine classifier is trained to detect the presence/absence of apnea/hypopnea events for each epoch. The number of epochs identified with events per hour value is calculated and subsequently mapped to AHI values using quadratic regression analysis in accordance with an embodiment. The classifier and regression models are optimized to minimize the mean-square error of AHI based on leave-one-out cross-validation.

[0023] FIG. 1 illustrates a wireless sensor device 100 for automated Apnea-Hypopnea Index (AHI) prediction in accordance with an embodiment. The wireless sensor device 100 ("wearable device") includes a sensor 102, a processor 104 coupled to the sensor 102, a memory 106 coupled to the

processor 104, an application 108 coupled to the memory 106, and a transmitter 110 coupled to the application 108.

[0024] In one embodiment, the wireless sensor device 100 is attached to a user to detect various physiological signals via the sensor 102. The sensor 102 obtains data from the user, which is transmitted to the memory 106 and in turn to the application 108 via the processor 104. The processor 104 executes the application 108 to process and analyze the data to obtain information regarding the user's health such as AHI values. The information is transmitted to the transmitter 110 and in turn relayed to another user or device for further processing, analysis, and storage. In another embodiment, the transmitter 110 transmits the various detected physiological signals in raw form to a remote device/server (e.g., smartphone, cloud-based server) for further processing, analysis, and storage.

[0025] In one embodiment, the sensor 102 is any of a microelectromechanical system (MEMS) tri-axial accelerometer and an embedded sensor with electrodes and the processor 104 is a microprocessor. One of ordinary skill in the art readily recognizes that a variety of devices can be utilized for the sensor 102, the processor 104, the memory 106, the application 108, and the transmitter 110 and that would be within the spirit and scope of the present invention.

[0026] Additionally, one of ordinary skill in the art readily recognizes that a variety of wireless sensor devices can be utilized including but not limited to wearable devices, a wireless sensor device in a patch form-factor, the Vital Connect HealthPatch™ wearable device, electrocardiograph devices, tri-axial accelerometers, uni-axial accelerometers, bi-axial accelerometers, gyroscopes, and pressure sensors and that would be within the spirit and scope of the present invention.

[0027] In one embodiment, the HealthPatch™ wearable device is a disposable adhesive patch biosensor worn on the chest that incorporates two surface electrodes with hydrogel on the bottom, a battery, an electronic module with an embedded processor and other electronic components and circuitry, a MEMS tri-axial accelerometer, and a Bluetooth Low Energy (BLE) transceiver.

[0028] In one embodiment, the wearable device facilitates continuous and automated monitoring of a plurality of physiological signals including but not limited to ECG and actigraphy signals at a sampling rate of 125 Hertz (Hz) and 62.5 Hz, respectively. In this embodiment, after the wearable device detects the plurality of physiological signals via a plurality of internal and embedded sensors, the electronic module of the wearable device utilizes a plurality of firmware algorithms to process the raw waveforms (of the plurality of physiological signals) and to transmit a stream of the processed physiological variables via the BLE transceiver/link as encrypted data to a relay such as a smartphone, where the live (real-time) streams of data can be viewed and stored.

[0029] To describe the features of the present invention in more detail, refer now to the following description in conjunction with the accompanying Figures.

[0030] FIG. 2 illustrates a flow chart of a system 200 for automated Apnea-Hypopnea Index (AHI) prediction in accordance with an embodiment. In one embodiment, the system 200 includes a HealthPatch™ wearable device/patch sensor 202, a relay device including but not limited to the patch sensor 202 itself or any of a smartphone, a wall unit relay, and a cloud processor 204, and a display device including but not limited to any of a computer screen, smartphone, screen and sensor display screen 206.

**[0031]** In another embodiment, the modules of the relay device **204** and the display device **206** are incorporated into the HealthPatch™ wearable device/patch sensor **202**. In another embodiment, the system **200** includes a different type of wearable device to detect the physiological signals and determine the sensor streams. In one embodiment, the HealthPatch™ patch sensor (wearable device) **202** includes a detection module and a sensor streams module; the relay device **204** includes a preprocessing module, epoch transformation module, feature extraction module, epoch classification module, and a regression analysis module; and the display device **206** outputs the predicted Apnea-Hypopnea Index (AHI) values.

**[0032]** FIG. 3 illustrates a more detailed flow chart of a system **300** for automated Apnea-Hypopnea Index (AHI) prediction in accordance with an embodiment. The system **300** includes a wearable device sensor **302** with embedded detection module, a subject info module **304**, a sensor streams module **306**, a preprocessing module **308**, an epoch based feature extraction module **310**, a machine learning or epoch classification module **312**, and a display module **314**. In one embodiment, each of the components (**302** to **314**) of the system **300** is coupled serially.

**[0033]** In one embodiment, the sensor stream unit **306**, the preprocessing unit **308**, the feature extraction unit **310**, the machine learning unit **312**, and the display unit **314** are all embedded within the wearable device **302** and operated together as an algorithm for automated prediction of Apnea-hypopnea Index. In another embodiment, the aforementioned units **306** to **314** are stand-alone devices that are coupled to and in communication with the wearable device **302** or are all combined to form one external system including but not limited to a relay/cloud processor (e.g., smartphone device).

**[0034]** In one embodiment, the subject info module **304** comprises patient demographic information (e.g., patient/doctor submitted) and sleep test questionnaire information; the sensor streams module **306** derives body impedance, RR intervals, QRS amplitude, QRS area, MEMS respiratory signals, activity, and posture angles; the preprocessing module **308** eliminates patch off instances (if any), eliminates trends and outliers, performs normalization, and allocates window based epochs; the feature extraction module **310** is epoch based and performs time-domain, frequency-domain, statistical, nonlinear, and posture analysis; the machine learning module **312** utilizes a feature vector derived from the extracted features, a feature vector derived from the subject info, and an optimized classifier model to classify the epochs, to estimate EPH values, and to map the EPH values to AHI values using regression analysis; and the display module **314** displays the AHI value and further categorizes the user into either control (AHI<5) or subgroups of SAS disorder. In one embodiment, the subgroups of SAS are defined as: mild apnea (AHI≥5 & AHI<15) subjects, moderate apnea (AHI≥15 & AHI<30) subjects and severe apnea (AHI≥30) subjects.

**[0035]** Sensor Streams Module:

**[0036]** The sensor streams module **306** analyzes physiological signal data that has been detected by the embedded detection module of the wearable device **302**. In one embodiment, the sensor streams module records a plurality of sensor streams for a predetermined time period including but not limited to seconds, minutes, hours, overnight, days, weeks, months, and years. The sensor streams module utilizes the physiological signal data to derive a plurality of sensor

streams and store the plurality of sensor streams on a memory device of the wearable device **302** at any of real-time or near real-time.

**[0037]** In one embodiment, the sensor streams derived from an ECG signal on a beat-to-beat basis include but are not limited to heart rate variability (HRV), QRS wave amplitude (RWA), and QRS wave area (RA). RWA and RA are defined as the range of ECG voltages and the absolute/signed area under the ECG signal, respectively, within a window of 100 milliseconds (ms) centered at the QRS peak of each beat. The sensor streams derived from tri-axial acceleration signals include but are not limited to MEMS-based respiration signals (RESP<sub>MEMS</sub>), signal magnitude area (SMA) as an activity metric, and polar angles of posture.

**[0038]** In one embodiment, the wearable device **302** also measures a body impedance value in between the two electrodes. In one embodiment, ECG derived signals are recorded on a beat-to-beat basis; SMA, posture angles and body impedance signals are sampled at a predetermined time period including but not limited to 4 seconds; and RESP<sub>MEMS</sub> signal is uniformly sampled at a predetermined frequency including but not limited to 4 Hz. In another embodiment, the SMA, posture angles and body impedance signals are sampled every predetermined seconds including but not limited to predetermined ranges within 1 to 60 seconds.

**[0039]** Preprocessing Module:

**[0040]** The preprocessing module **308** processes the plurality of sensor streams that have been derived and transmitted by the sensor streams module. In one embodiment, the preprocessing module eliminates patch off instances using body impedance. Tremendous shifts (artifacts) in the very low frequency trend of respiratory signals are caused by overnight changes in sleep postures including but not limited to supine, prone, left side and right side. The artifact trends are eliminated using a moving average filter with N beats, where  $N = \alpha \times \text{user's average heart rate}$ , where  $\alpha$  is the number of minutes (e.g., 3). In one embodiment, artifacts/outlier samples of the sensor streams are identified and eliminated if they are outside their respective  $MN \pm \beta \times SD$ , where MN refers to the mean value of the respective overnight sensor stream,  $\beta$  is an integer and SD refers to the standard deviation of the respective overnight sensor stream.

**[0041]** In one embodiment, the preprocessing module **308** also normalizes the overnight sensor streams. In one embodiment, the normalization of ECG derived respiration signals is done by applying a filter on the RWA and RA series to calculate a moving standard deviation with customized samples to the user (e.g.,  $\alpha \times \text{user's average HR}$ ). The RWA and RA series are normalized by their respective moving standard deviation values. In another embodiment, the normalization of MEMS derived respiration signals (e.g., Resp<sub>MEMS</sub>) is done by applying a filter on the Resp<sub>MEMS</sub> signal to calculate a moving standard deviation with  $(\alpha \times 60 \times \text{sampling rate of Resp}_{MEMS} \text{ signal})$  samples, where  $\alpha$  is the number of minutes (e.g., 3). The Resp<sub>MEMS</sub> signal is normalized by its moving standard deviation values.

**[0042]** In one embodiment, the preprocessed overnight sensor streams are transformed by the epoch transformation module into nonoverlapping epochs of a predetermined time window including but not limited to a 150 second (s) window.

**[0043]** Feature Extraction Module:

**[0044]** The epoch based feature extraction module **310** receives the preprocessed sensor streams from the sensor streams module and extracts a plurality of features. In one

embodiment, features are calculated based on the epochs of the preprocessed sensor streams using time-domain, frequency-domain, and nonlinear techniques. The time-domain features are obtained for the series of HRV, RWA, RA, RESP-<sub>MEMS</sub>, and SMA and include but are not limited to median, standard deviation, coefficient of variation, mean absolute deviation, kurtosis, interquartile range, dispersion metric as the difference between 90<sup>th</sup> and 10<sup>th</sup> percentiles, and approximate entropy.

**[0045]** In one embodiment, the beat-to-beat HRV data is further analyzed to obtain statistical features that include but are not limited to root mean square and standard deviation of successive differences of NN intervals and percentage of successive NN intervals that differ by 50 ms, and nonlinear Poincare plot features: long-term variability, short-term variability, and area of the fitted ellipse.

**[0046]** In one embodiment, the feature extraction module extracts frequency-domain features from uniformly sampled (e.g., 4 Hz) series of HRV, RWA, RA, and RESP-<sub>MEMS</sub>. In one embodiment, a power spectral density estimate is obtained using Welch's averaged, modified periodogram method with 50% overlap and Hamming windows. The frequency-domain features include but are not limited to total, very low frequency (VLF), low frequency (LF), and high frequency (HF) band power and their normalized values, LF/HF ratio, spectral kurtosis, spectral entropy, and peak-to-mean ratio.

**[0047]** In one embodiment, accelerometer data is used to obtain posture related features that include but are not limited to mean overnight posture, mean posture polar angles, and the number of overnight posture transitions. The feature extraction module combines all of the aforementioned extracted physiological features to form a feature vector (Fv) that is input into the epoch classification module.

**[0048]** In another embodiment, the feature extraction module **310** combines all of the aforementioned extracted physiological features and patient information to form a feature vector (Fv) that is input into the epoch classification module. The patient information consists of demographic information including but not limited to height, weight, age, neck circumference, body mass index, and gender, and responses to a plurality of sleep related questionnaires including but not limited to STOP\_BANG questionnaire, Epworth Sleepiness scale and Berlin questionnaire.

**[0049]** Epoch Classification Module:

**[0050]** The epoch classification module **312** utilizes a machine learning classifier to classify the nonoverlapping epochs using the feature vector (Fv). The machine learning classifier may be any classifier in which probabilistic outputs can be estimated, including but not limited to Support vector machines (SVM), Naïve-Bayes classifier, and random forests classifier. In one embodiment, linear SVM are a type of machine learning classifier that benefit from flexibility, computational efficiency, and a capacity to handle high dimensional data. In one embodiment, the training data is set per the following equation:  $\{X_i, y_i\}, i=1, \dots, l, X_i \in \mathbb{R}^d, y_i \in \{-1, 1\}$ , where  $l$  is the number of training examples and  $d$  is the number of features. The linear SVM classifier solves the optimization problem per the following equation:

$$\min_{w,b,\xi} = \left\{ \frac{\|W\|^2}{2} + C \sum_{i=1}^l \xi_i \right\},$$

subject to  $y_i(W^T X_i + b) \leq 1 - \xi_i$ , where  $\xi_i \geq 0$  is a loss function and  $C > 0$  is a penalty factor.

**[0051]** In one embodiment, a linear SVM classifier model is trained and optimized to classify each epoch with absence/presence of apnea/hypopnea events using the feature vector Fv and the reference epoch class labels  $y_i \in \{-1, 1\}$ . The optimized binary classifier model is later used to predict the epochs with apnea/hypopnea events for a given feature vector Fv of a test or input data set. The number of epochs with events per hour (EPH) is calculated based on the predicted labels. EPH value is generally calculated as

$$EPH = \frac{P}{(P+N)} \times \frac{3600}{WL}$$

where P is the number of positive epochs, N is the number of negative epochs, and WL is the epoch window length.

**[0052]** Regression Analysis Module:

**[0053]** The regression analysis module **312** maps the EPH values to AHI value using regression analysis. In one embodiment, the relationship between the EPH values and the AHI values is found to be nonlinear because the EPH value reaches a plateau as a function of AHI value based on the epoch window length. Therefore, a second order regression model is trained for fitting the relationship between EPH and AHI values per the following equation:  $y = \beta_2 x^2 + \beta_1 x + \beta_0$  where  $x$  is the input EPH value,  $y$  is the AHI output value,  $\beta_2$  is the quadratic effect parameter,  $\beta_1$  is the linear effect parameter, and the intercept  $\beta_0$  is set to be zero.

**[0054]** FIG. 5 illustrates a graph **500** depicting regression analysis in accordance with an embodiment. In FIG. 5, the reference EPH-<sub>PSG</sub> and AHI-<sub>PSG</sub> values of training data sets are used to obtain the quadratic regression model using least squares estimation. Based on the trained second order regression model with the coefficients of linear and quadratic components, the input predicted EPH value is mapped to an output predicted AHI value.

**[0055]** FIG. 6 illustrates a graph **600** depicting a high linear correlation between the predicted AHI values and the reference AHI values derived from standard PSG testing in accordance with an embodiment. In one embodiment, the reference AHI values are derived from standard PSG testing and in another embodiment the reference AHI values are derived from user inputs into a cloud-based database. To arrive at the comparison depicted by the graph **600**, the quadratic regression model that is trained with epochs with events per hour (EPH) and apnea-hypopnea index (AHI) from the standard PSG testing is used to predict the AHI values for the given data (e.g., test data). The details of the optimization process **400** utilized for the AHI prediction are further described below.

**[0056]** Display Module:

**[0057]** In one embodiment, the predicted AHI value will be displayed on the display module **314** (e.g., smartphone application screen). The predicted AHI value will determine the presence of severity of SAS disorder. Accordingly, the user can be categorized into either control or subgroups of apnea. In one embodiment, the subgroups of SAS are defined as: mild apnea (AHI  $\geq 5$  & AHI  $< 15$ ) subjects, moderate apnea (AHI  $\geq 15$  & AHI  $< 30$ ) subjects and severe apnea (AHI  $\geq 30$ ) subjects. The display module **314** can display the user's category as any of control, mild apnea, moderate apnea, severe apnea.

**[0058]** In one embodiment, based on the predicted AHI value, the user can be further classified into binary classifier groups that provide a positive and negative category of two predefined groups. In one embodiment, the binary classifier groups include any of: a) a control (AHI<5) versus apnea subjects (AHI>=5); b) apnea low-risk (e.g., control-to-mild apnea (AHI<15)) versus apnea high-risk (e.g., moderate-to-severe apnea (AHI>=15) subjects); and c) control-to-moderate apnea (AHI<30) versus severe apnea (AHI>=30) subjects.

**[0059]** Based on the predicted AHI value, the display unit will display either a “RED” or a “GREEN” light on a toggle arrangement panel indicating the subject might belong to positive or negative category of the specified binary classifier group, respectively. One of ordinary skill in the art readily recognizes that a variety of display mechanisms can be utilized by the display unit and that would be within the spirit and scope of the present invention.

**[0060]** An optimization process of the classifier model is utilized to minimize the mean square error of the predicted AHI value. FIG. 4 illustrates a detailed flow chart of an optimization process 400 of the classifier model in accordance with an embodiment. The optimization process 400 involves leave-one-out cross validation (LOOCV) and generates a classifier model with optimal parameters for the accurate binary classification of each epoch to determine whether the epoch is either present or absent with an apnea/hypopnea event. The epoch classification module of 312 utilizes the optimized classifier model and feature vector Fv as inputs and generates binary classification output for each epoch.

**[0061]** The optimization 400 process defines an array of parameters (e.g., cost function C for linear support vector machines), via step 402; loops through the parameter values, via step 404; for each value of classifier model parameter, the feature matrix obtained from L+1 subjects (via step 405) is split into a training and a validation data set according to LOOCV, via step 406; performs scaling of the training set, via step 408; performs scaling of the validation set using the shift and scale factors obtained from training set, via step 410; trains an epoch based classifier model using the training epoch data set, model parameter, and the reference class of the training epoch data set, via step 412; predicts the class of epochs using the scaled validation data set and trained classifier model, via step 414; calculates the number of epochs with events per hour ( $EPH_{Pred}$ ) based on the predicted epoch labels, via step 416; predicts the AHI value ( $AHI_{Pred}$ ) based on the  $EPH_{Pred}$  and the regression model trained with the reference  $EPH_{PSG}$  and  $AHI_{PSG}$  values of training data sets, via step 418; stores the predicted AHI values in an array of length L+1, via step 420; and determines whether L+1 LOOCV cycles is completed via step 422.

**[0062]** If the L+1 LOOCV cycles are not complete, the optimization process 400 continues to repeat the steps 405 through 424 and obtains predictions of  $AHI_{Pred}$  for L+1 validation feature set, via step 420. If the L+1 LOOCV cycles are complete, the optimization 400 calculates the mean square error (MSE) that compares the reference AHI values and the predicted AHI values, via step 426, and stores the MSE estimate in an array of classifier parameter’s length via step 428.

**[0063]** The optimization process 400 then determines whether the looping of classifier parameter values is complete, via step 430. If the loop is not complete, the optimization process 400 repeats the steps 404 through 430 and obtains MSE values for each looping cycle, via step 428. If the

loop is complete, the optimization 400 determines the least MSE value among the computed MSE values, via step 432 and obtains the optimal classifier model parameter as the one that produced the least MSE, via step 434. Thus, in accordance with an embodiment, the optimization 400 process optimizes the optimal penalty factor C for the binary SVM classifier model that can accurately predict the epoch’s binary classes to minimize the MSE of the AHI prediction with the quadratic regression model.

**[0064]** In this embodiment, for each value of a predefined C array, the EPH values are obtained from the linear SVM classifier, applied to the trained quadratic regression model, and AHI values are predicted for (L+1) LOOCV cycles, where L is the number of training subjects. The MSE of the predicted AHI is calculated with respect to the AHI values derived from standard PSG testing and stored in an array of same size of C. The MSE values are similarly obtained for all the other C values using LOOCV. The optimal penalty parameter for linear SVM classifier is found to be the one that offers the least MSE error of AHI. The optimization process provides the highest performance and improved generalization capabilities.

**[0065]** In one embodiment, a wireless sensor such as a patch sensor is placed at one of the three locations on the user/patient’s chest and data that is collected overnight at any one of the three locations is used to automatically predict AHI value using the current algorithm. The data from each of the three chest locations have unique morphology and characteristics of raw and derived signals. Therefore, in this embodiment, three independent classifier models combined with regression analysis are trained and optimized separately to produce accurate prediction of AHI with respective to each patch sensor location. The AHI values are accurately predicted by attaching the wireless sensor at any one of the three locations on the user/patient’s chest.

**[0066]** In one embodiment, overnight physiological monitoring with a wearable device as above-described (e.g., HealthPatch™ adhesive sensor) provides an accurate estimate of AHI values compared to standard PSG testing. In this embodiment, the wearable device with the current AHI prediction algorithm utilizes ECG and actigraphy signals alone and without blood oxygen saturation/airflow signals. Conventional wristwatch, wristband, and bracelet devices offer sleep-awake patterns primarily based on actigraphy signals, but these devices are not capable of AHI quantification or sleep apnea screening (SAS).

**[0067]** In one embodiment, the wearable device is disposable, inexpensive, unobtrusive, simple to attach, and easy to connect/pair wirelessly with external devices including but not limited to the user/patient’s smartphone. The physiological and sensor stream data is encrypted and transmitted via a BLE link to external relay processor (e.g., smartphone) for further processing to automatically predict AHI values and then stored for further analysis and viewing. The predicted AHI values are displayed on the smartphone application screen/computer screen. From the smartphone/server, an analysis report is produced that can be easily sent to a physician or a family member. The user can wear the wearable device for multiple nights in a row that can increase the confidence in the sleep apnea screening outcome such as predicted AHI value.

**[0068]** FIG. 7 illustrates a method 700 for automated Apnea-Hypopnea Index (AHI) prediction in accordance with an embodiment. The method 700 comprises determining at

least one sensor stream using at least one detected physiological signal into, via step 702, and processing the at least one sensor stream to automatically determine the AHI values, via step 704. In another embodiment, the method further includes detecting physiological signals that include but are not limited to ECG and accelerometer signals using at least one wearable device.

[0069] In one embodiment, the converting step is performed by an electronic module of the wearable device, further wherein the at least one sensor stream includes any of an RR interval, an amplitude of the QRS waveform (RWA), an area of the QRS waveform (RA), a MEMS derived respiration signal, a signal magnitude area (SMA) of an accelerometer signal, and a posture angle. In one embodiment, the processing step further comprises preprocessing the at least one sensor stream, performing feature extraction on the at least one preprocessed sensor stream to provide a feature vector, and performing machine learning optimization using the feature vector.

[0070] In one embodiment, the processing step is performed by any of a wearable device, an external device, a relay/cloud processor, a smartphone device, and a cloud computing system. In one embodiment, the preprocessing step further comprises any of eliminating wearable device off instances, removing trends, detecting and removing outliers, detecting and removing artifacts, normalization of ECG derived respiration signals, and normalization of MEMS derived respiration signals.

[0071] In one embodiment, the performing feature extraction step utilizes any of time-domain analysis, statistical analysis, nonlinear analysis, frequency-domain analysis, and posture analysis to extract features from the at least one preprocessed sensor stream. In another embodiment, the method further includes determining the feature vector using a combination of the feature extraction and patient information.

[0072] In one embodiment, the performing machine learning optimization step utilizes the feature vector and an optimized classifier model to perform epoch classification and to determine a number of epochs with events per hour (EPH). In another embodiment, the method further includes performing regression analysis to map the EPH to the determined AHI values and minimizing mean square error (MSE) of the determined AHI values using leave-one-out cross-validation (LOOCV).

[0073] In one embodiment, a wearable device for determining Apnea-Hypopnea Index (AHI) values comprises a sensor to detect at least one physiological signal, a processor coupled to the sensor, and a memory device coupled to the processor, wherein the memory device includes an application that, when executed by the processor, causes the processor to perform the aforementioned steps of the method.

[0074] As above described, a method and system in accordance with the present invention utilizes a wearable device (e.g., HealthPatch™ patch sensor) to provide automated Apnea-Hypopnea Index (AHI) prediction. By utilizing wearable devices to detect a plurality of physiological signals (e.g., ECG), utilizing a plurality of embedded sensors (e.g., any of an ECG sensor, a MEMS accelerometer, and derived sensors), and utilizing a processor (e.g., any of an embedded electronic module/processor in the wearable device, an external relay/cloud processor such as a smartphone device, and a cloud computing system) to perform preprocessing, feature extraction, and machine learning prediction and regression

model analytics, the method and system in accordance with the present invention continuously and automatically screens a patient for SAS and then automatically determines the severity of the SAS via AHI value prediction.

[0075] A method and system for automated Apnea-Hypopnea Index (AHI) prediction has been disclosed. Embodiments described herein can take the form of an entirely hardware implementation, an entirely software implementation, or an implementation containing both hardware and software elements. Embodiments may be implemented in software, which includes, but is not limited to, application software, firmware, resident software, microcode, etc.

[0076] The steps described herein may be implemented using any suitable controller or processor, and software application, which may be stored on any suitable storage location or calculator-readable medium. The software application provides instructions that enable the processor to perform the functions described herein.

[0077] Furthermore, embodiments may take the form of a calculator program product accessible from a calculator-usable or calculator-readable medium providing program code for use by or in connection with a calculator or any instruction execution system. For the purposes of this description, a calculator-usable or calculator-readable medium can be any apparatus that can contain, store, communicate, propagate, or transport the program for use by or in connection with the instruction execution system, apparatus, or device.

[0078] The medium may be an electronic, magnetic, optical, electromagnetic, infrared, semiconductor system (or apparatus or device), or a propagation medium. Examples of a calculator-readable medium include a semiconductor or solid state memory, magnetic tape, a removable calculator diskette, a random access memory (RAM), a read-only memory (ROM), a rigid magnetic disk, and an optical disk. Current examples of optical disks include DVD, compact disk-read-only memory (CD-ROM), and compact disk-read/write (CD-R/W).

[0079] Although the present invention has been described in accordance with the embodiments shown, one of ordinary skill in the art will readily recognize that there could be variations to the embodiments and those variations would be within the spirit and scope of the present invention. Accordingly, many modifications may be made by one of ordinary skill in the art without departing from the spirit and scope of the appended claims.

What is claimed is:

1. A method for determining Apnea-Hypopnea Index (AHI) values, the method comprising:

determining at least one sensor stream using at least one detected physiological signal; and  
processing the at least one sensor stream to automatically determine the AHI values.

2. The method of claim 1, wherein the at least one detected physiological signal is detected by a wearable device and includes any of an ECG signal and an accelerometer signal.

3. The method of claim 2, wherein the determining step is performed by an electronic module of the wearable device, further wherein the at least one sensor stream includes any of an RR interval, an amplitude of the QRS waveform (RWA), an area of the QRS waveform (RA), a MEMS derived respiration signal, a signal magnitude area (SMA) of an accelerometer signal, and a posture angle.

4. The method of claim 1, wherein the processing step further comprises:

preprocessing the at least one sensor stream;  
 performing feature extraction on the at least one preprocessed sensor stream to provide a feature vector; and  
 performing machine learning optimization using the feature vector.

5. The method of claim 1, wherein the processing step is performed by any of a wearable device, an external device, a relay/cloud processor, a smartphone device, and a cloud computing system.

6. The method of claim 4, wherein the preprocessing step further comprises any of eliminating wearable device off instances, removing trends, detecting and removing outliers, detecting and removing artifacts, normalization of ECG derived respiration signals, and normalization of MEMS derived respiration signals.

7. The method of claim 4, wherein the performing feature extraction step utilizes any of time-domain analysis, statistical analysis, nonlinear analysis, frequency-domain analysis, and posture analysis to extract features from the at least one preprocessed sensor stream.

8. The method of claim 4, further comprising:  
 determining the feature vector using a combination of the feature extraction and patient information.

9. The method of claim 4, wherein the performing machine learning optimization step utilizes the feature vector and an optimized classifier model to perform epoch classification and to determine a number of epochs with events per hour (EPH).

10. The method of claim 9, further comprising:  
 performing regression analysis to map the EPH to the determined AHI values; and  
 minimizing mean square error (MSE) of the determined AHI values using leave-one-out cross-validation (LOOCV).

11. A wearable device for determining Apnea-Hypopnea Index (AHI) values, the wearable device comprising a sensor to detect at least one physiological signal, a processor coupled to the sensor, and a memory device coupled to the processor, wherein the memory device includes an application that, when executed by the processor, causes the processor to:

convert the at least one detected physiological signal into at least one sensor stream; and

process the at least one sensor stream to automatically determine the AHI values.

12. The wearable device of claim 11, wherein the at least one physiological signal includes any of an ECG signal and an accelerometer signal.

13. The wearable device of claim 12, wherein the at least one sensor stream includes any of an RR interval, an amplitude of the QRS waveform (RWA), an area of the QRS waveform (RA), a MEMS derived respiration signal, a signal magnitude area (SMA) of an accelerometer signal, and a posture angle.

14. The wearable device of claim 11, wherein to process further comprises to:

perform preprocessing on the at least one sensor stream;  
 perform feature extraction on the at least one preprocessed sensor stream to provide a feature vector; and  
 perform machine learning optimization using the feature vector.

15. The wearable device of claim 14, wherein any of the preprocessing, feature extraction, and machine learning optimization is performed by a processor external to the wearable device, wherein the external processor includes any of an external device, a relay/cloud processor, a smartphone device, and a cloud computing system.

16. The wearable device of claim 14, wherein the preprocessing further comprises any of eliminating wearable device off instances, removing trends, detecting and removing outliers, detecting and removing artifacts, normalization of ECG derived respiration signals, and normalization of MEMS derived respiration signals.

17. The wearable device of claim 14, wherein the feature extraction utilizes any of time-domain analysis, statistical analysis, nonlinear analysis, frequency-domain analysis, and posture analysis to extract features from the at least one preprocessed sensor stream.

18. The wearable device of claim 14, wherein the application, when executed by the processor, further causes the processor to:

determine the feature vector using a combination of the feature extraction and patient information.

19. The wearable device of claim 14, wherein the machine learning optimization utilizes the feature vector and an optimized classifier model to perform epoch classification and to determine a number of epochs with events per hour (EPH).

20. The wearable device of claim 1, wherein the application, when executed by the processor, further causes the processor to:

perform regression analysis to map the EPH to the determined AHI values; and

minimize mean square error (MSE) of the determined AHI values using leave-one-out cross-validation (LOOCV).

\* \* \* \* \*

专利名称(译)	使用可穿戴设备自动预测呼吸暂停 - 低通气指数		
公开(公告)号	<a href="#">US20150164411A1</a>	公开(公告)日	2015-06-18
申请号	US14/274313	申请日	2014-05-09
[标]申请(专利权)人(译)	维塔尔康奈克特公司		
申请(专利权)人(译)	VITAL CONNECT, INC.		
当前申请(专利权)人(译)	VITAL CONNECT, INC.		
[标]发明人	SELVARAJ NANDAKUMAR NARASIMHAN RAVI		
发明人	SELVARAJ, NANDAKUMAR NARASIMHAN, RAVI		
IPC分类号	A61B5/00 A61B5/04 A61B5/11 A61B5/0456 A61B5/0205 A61B5/0402		
CPC分类号	A61B5/4818 A61B5/0205 A61B5/0402 A61B5/1116 A61B5/7203 A61B5/1121 A61B5/04012 A61B5/6801 A61B5/0006 A61B5/0456 A61B5/0004 A61B5/0452 A61B5/11 A61B5/6833 A61B5/7267 G16H50/70		
优先权	61/916024 2013-12-13 US		
外部链接	<a href="#">Espacenet</a> <a href="#">USPTO</a>		

摘要(译)

公开了一种用于确定呼吸暂停 - 呼吸不足指数 (AHI) 值的方法和系统。该方法包括使用至少一个检测到的生理信号确定至少一个传感器流, 并处理该至少一个传感器流以自动确定AHI值。该系统包括用于检测至少一个生理信号的传感器, 耦合到传感器的处理器, 以及耦合到处理器的存储器设备, 其中存储器设备包括当由处理器执行时使处理器确定的应用程序。至少一个传感器流使用至少一个检测到的生理信号并处理该至少一个传感器流以自动确定AHI值。

