



(19) **United States**
(12) **Patent Application Publication**
Ghosh et al.

(10) **Pub. No.: US 2014/0323882 A1**
(43) **Pub. Date: Oct. 30, 2014**

(54) **SYSTEMS, METHODS, AND INTERFACES FOR IDENTIFYING OPTIMAL ELECTRICAL VECTORS**

Publication Classification

(71) Applicant: **Medtronic, Inc.**, Minneapolis, MN (US)

(51) **Int. Cl.**
A61B 5/044 (2006.01)
A61B 5/0205 (2006.01)
A61B 5/00 (2006.01)
A61N 1/365 (2006.01)

(72) Inventors: **Subham Ghosh**, Blaine, MN (US);
Jeffrey Gillberg, Coon Rapids, MN (US);
Manfred Justen, Lino Lakes, MN (US);
Eric Schilling, Ham Lake, MN (US)

(52) **U.S. Cl.**
CPC *A61B 5/044* (2013.01); *A61N 1/365* (2013.01); *A61N 1/36585* (2013.01); *A61B 5/0205* (2013.01); *A61B 5/4029* (2013.01)
USPC **600/483**; 607/17; 607/18; 600/510

(73) Assignee: **Medtronic, Inc.**, Minneapolis, MN (US)

(57) **ABSTRACT**

(21) Appl. No.: **14/227,919**

Systems, methods, and graphical user interfaces are described herein for identification of optimal electrical vectors for use in assisting a user in implantation of implantable electrodes to be used in cardiac therapy. Cardiac improvement information may be generated for each pacing configuration, and one or more pacing configuration may be selected based on the cardiac improvement information. Optimal electrical vectors using the selected pacing configurations may be identified using longevity information generated for each electrical vector. Electrodes may then be implanted for use in cardiac therapy to form the optimal electrical vector.

(22) Filed: **Mar. 27, 2014**

Related U.S. Application Data

(60) Provisional application No. 61/817,480, filed on Apr. 30, 2013, provisional application No. 61/913,784, filed on Dec. 9, 2013.

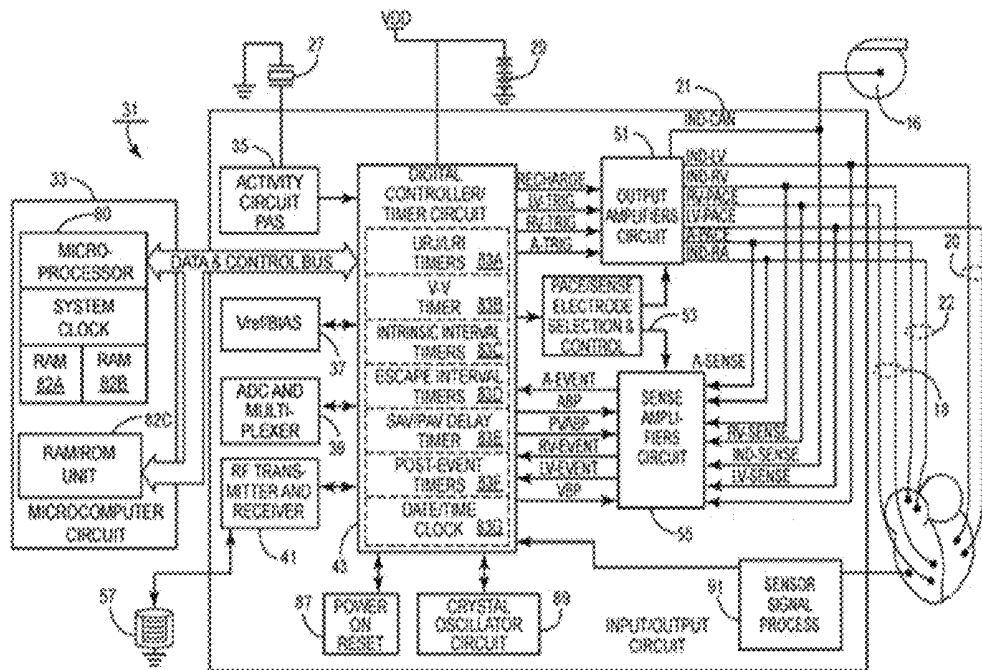

FIG. 1

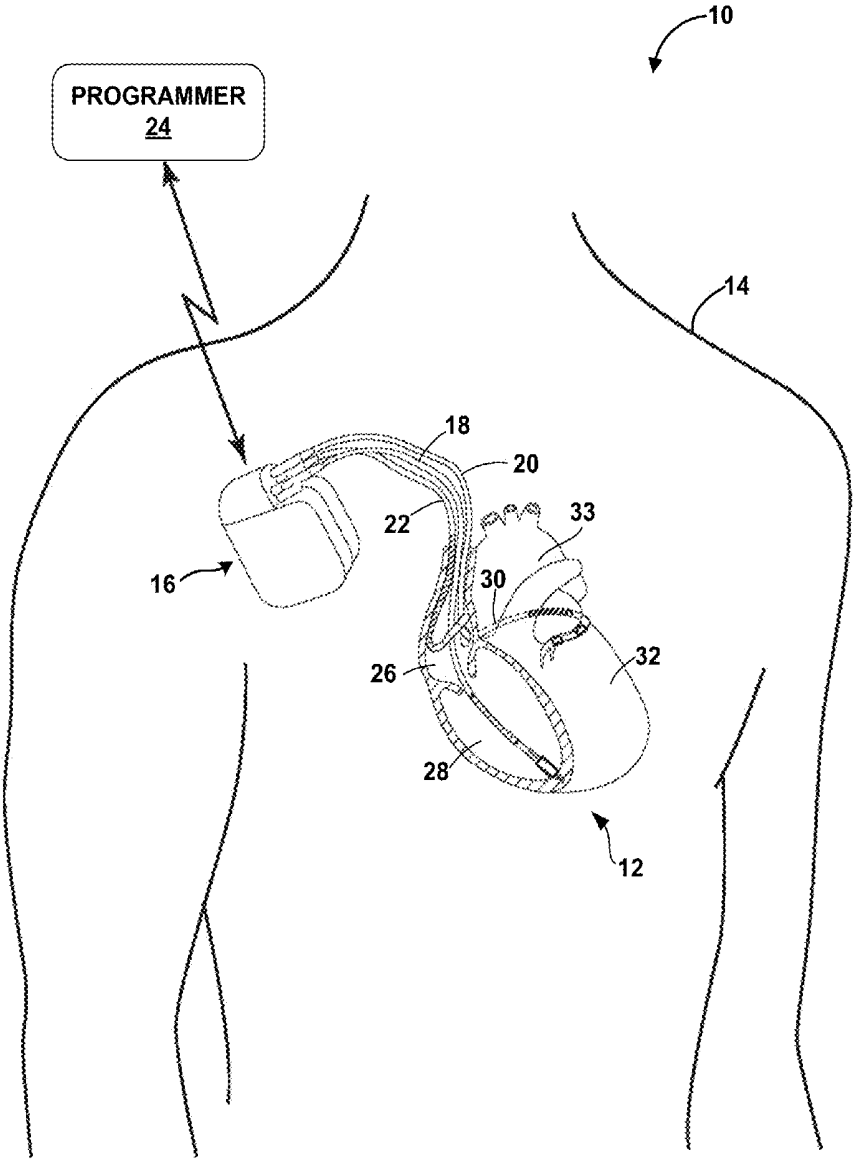

FIG. 2A

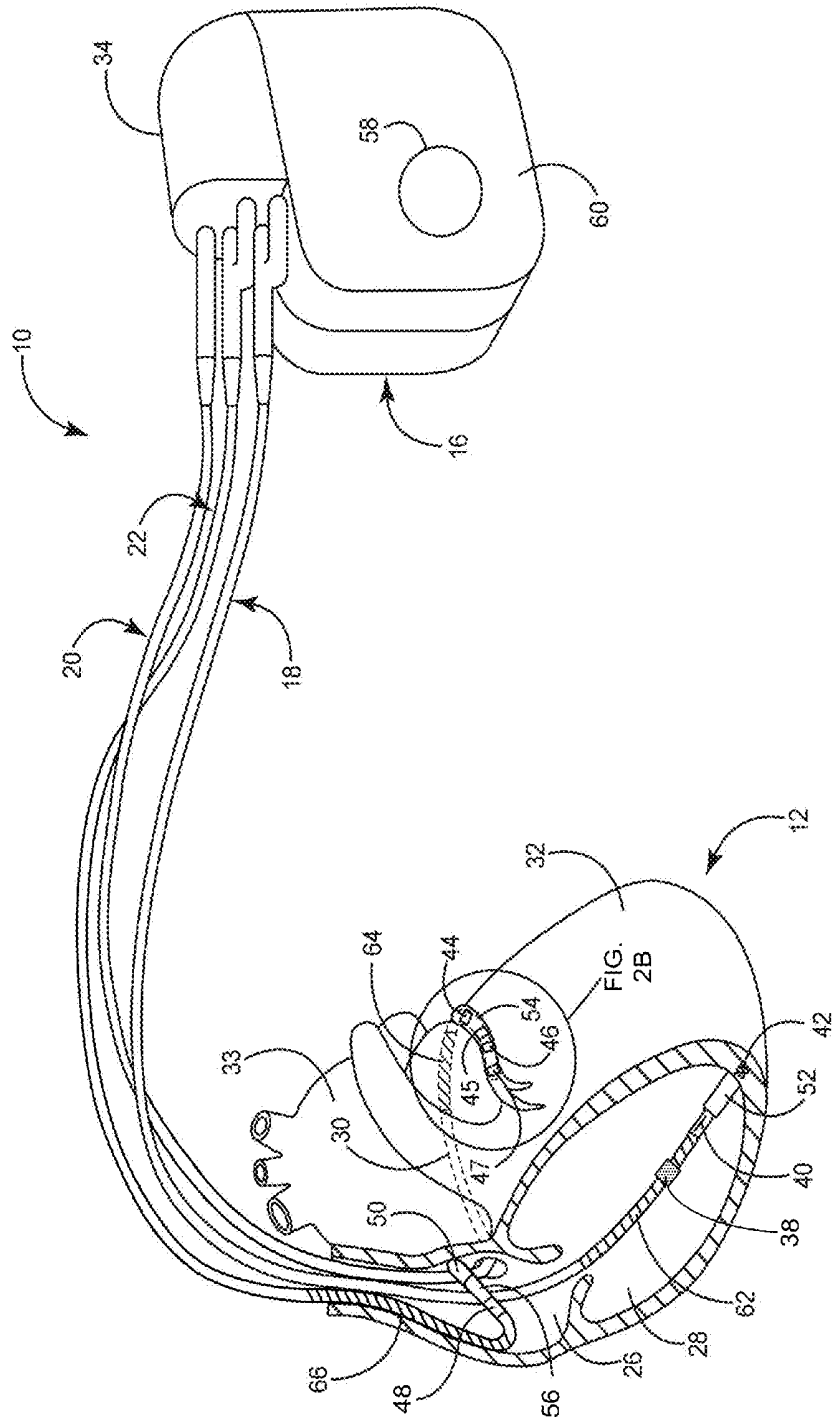

FIG. 2B

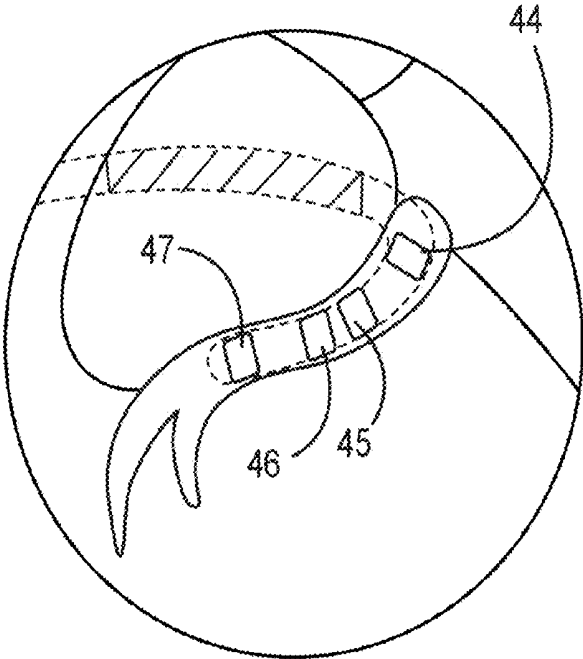

FIG. 3A

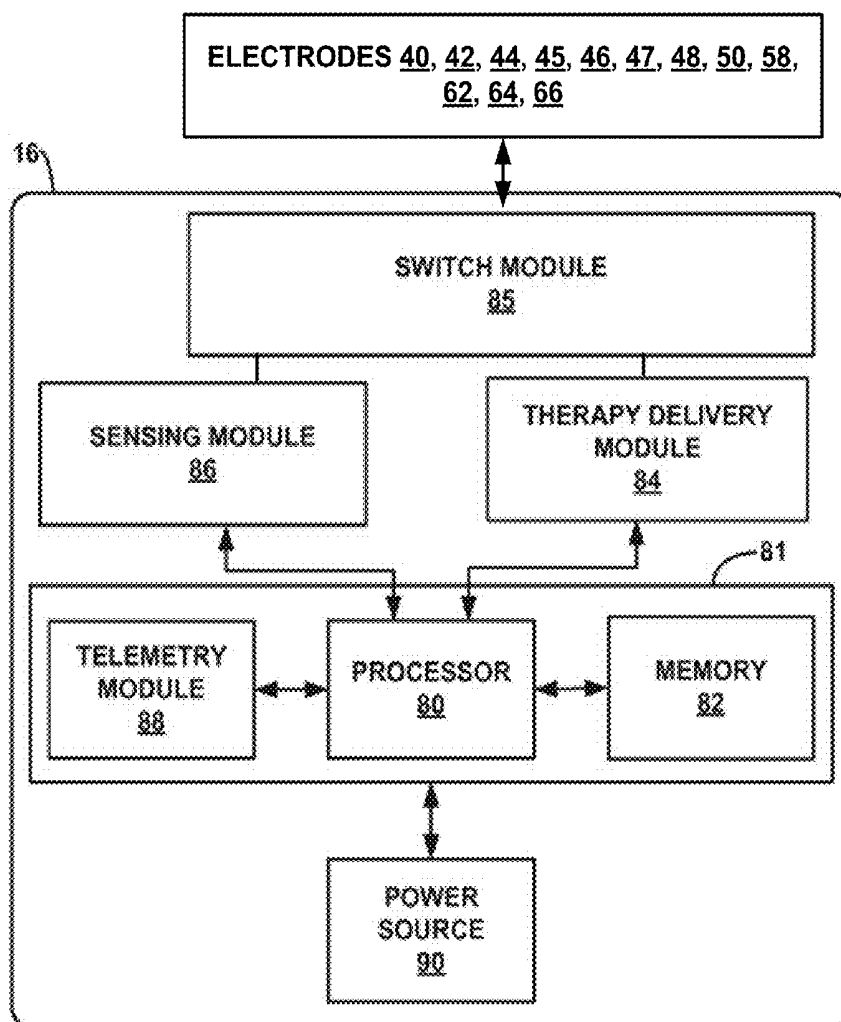

FIG. 3B

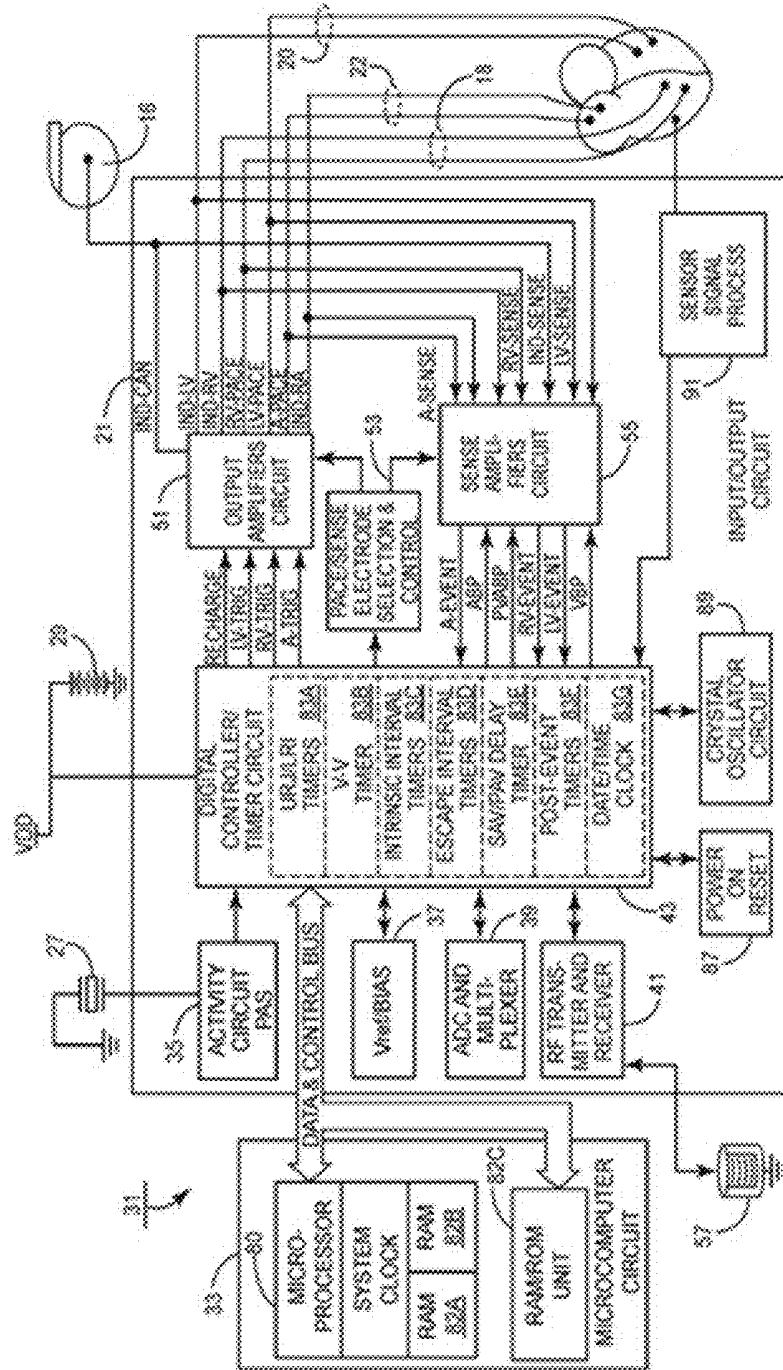

FIG. 4

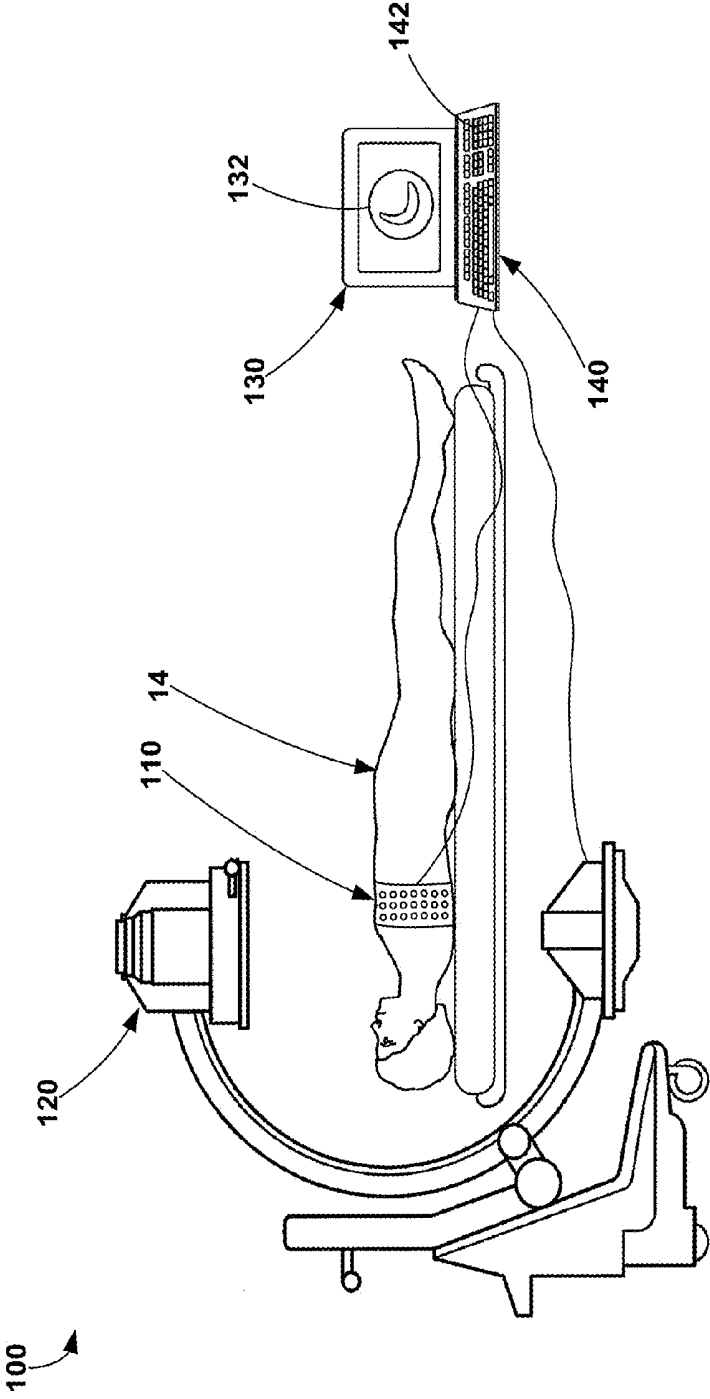

FIG. 5A

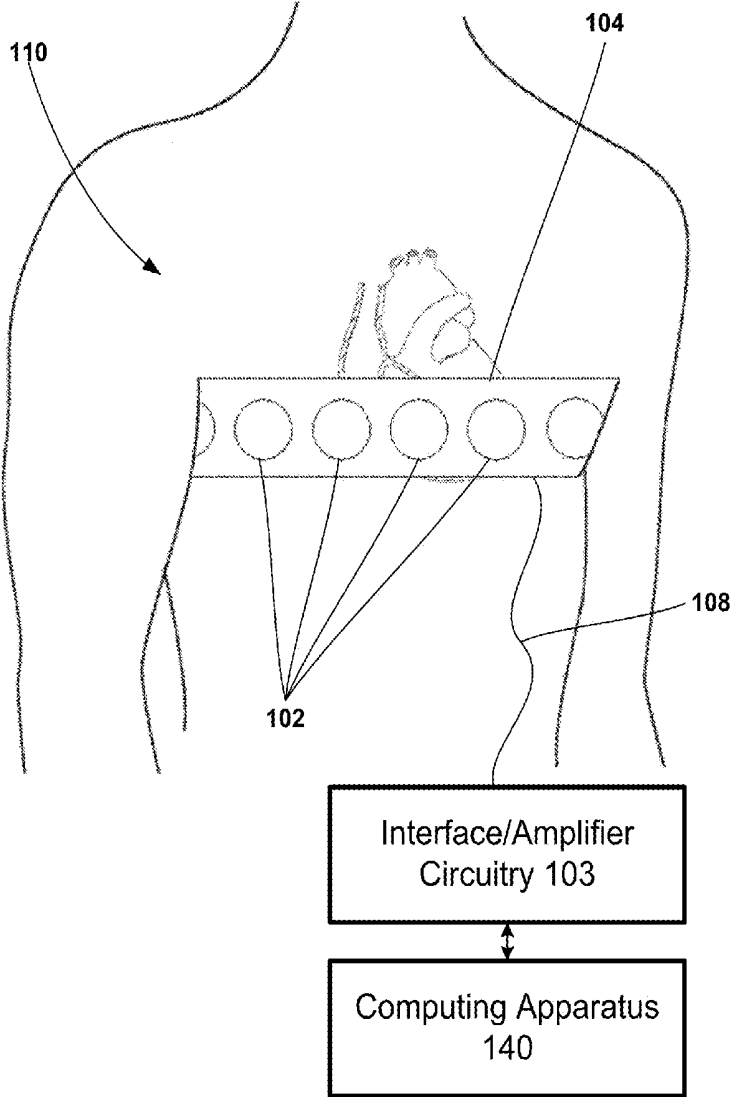

FIG. 5B

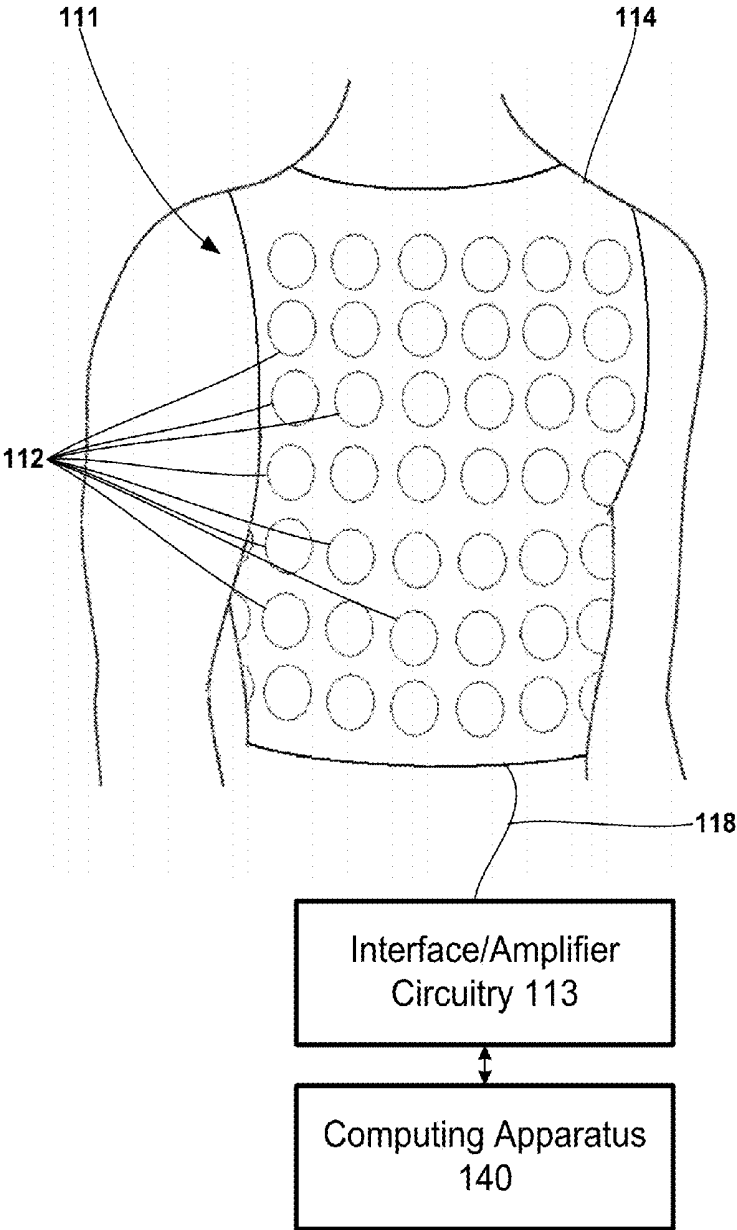

FIG. 6

150

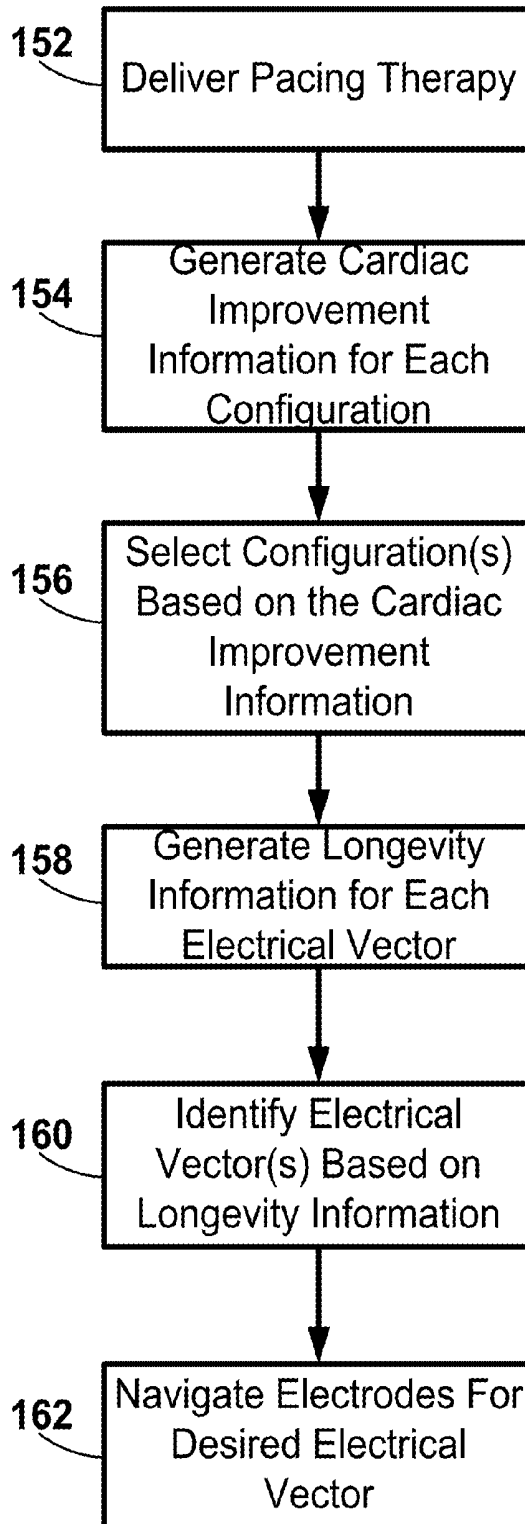

FIG. 7

132

LV electrode	Relative improvement in resynchronization
LV1	5%
LV2	3.50%
LV3	2.50%
LV4	-5%

FIG. 8

132

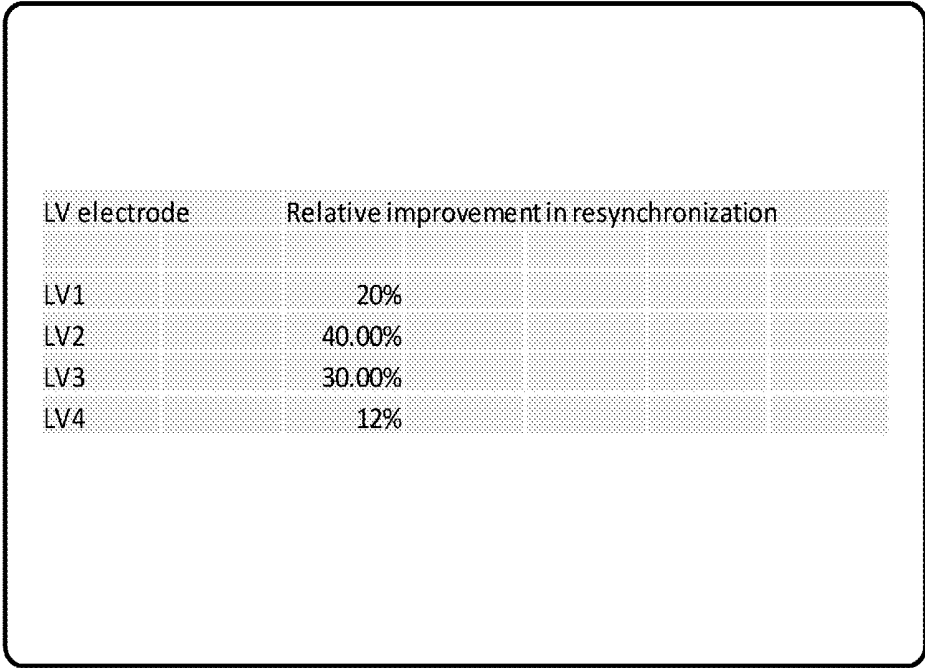

LV electrode	Relative improvement in resynchronization
LV1	20%
LV2	40.00%
LV3	30.00%
LV4	12%

FIG. 9

132

172

Pacing Vector	Relative Longevity	Phrenic Nerve Stim present
LV2-RV Coil	3 months less	Absent
LV2-LV1	6 months less	Absent
LV2-LV3	Maximum	Absent
LV2-LV4	Maximum	Present
LV3-RVCoil	5 months less	Absent
LV3-LV1	4 months less	Absent
LV3-LV2	3 months less	Absent
LV3-LV4	1 year less	Present

FIG. 10

132

LV Pace Polarity	Relative Longevity	Capture Threshold	Last Impedance	Phrenic Nerve Stimulation	Change in Dyssynchrony Index
LV1 to Rvcoil	2 months less	0.75 V @ 0.40 ms	589 ohms	Not Tested	+5%
LV1 to LV2	5 months less	1.25 V @ 0.40 ms	874 ohms	Not Tested	+1%
LV1 to LV3	Maximum	1.00 V @ 0.40 ms	855 ohms	No	
LV1 to LV4	Maximum	1.00 V @ 0.40 ms	836 ohms	Not Tested	
LV2 to Rvcoil	7 months less	1.00 V @ 0.40 ms	399 ohms	Not Tested	+1%
LV2 to LV1	7 months less	1.75 V @ 0.40 ms	874 ohms	Not Tested	
LV2 to LV3	1.1 years less	1.25 V @ 0.40 ms	437 ohms	Not Tested	
LV2 to LV4	9 months less	1.25 V @ 0.40 ms	589 ohms	Not Tested	
LV3 to Rvcoil	6 months less	0.75 V @ 0.40 ms	361 ohms	Not Tested	
LV3 to LV1	7 months less	1.75 V @ 0.40 ms	855 ohms	Not Tested	+1%
LV3 to LV2	1.1 years less	1.25 V @ 0.40 ms	437 ohms	Not Tested	
LV3 to LV4	9 months less	1.25 V @ 0.40 ms	570 ohms	Not Tested	-10%
LV4 to Rvcoil	1.5 years less	1.25 V @ 0.40 ms	304 ohms	Not Tested	-15%
LV4 to LV1	1.4 years less	3.00 V @ 0.40 ms	836 ohms	Not Tested	
LV4 to LV2	***	***	589 ohms	Not Tested	
LV4 to LV3	***	***	570 ohms	Not Tested	

FIG. 11

132

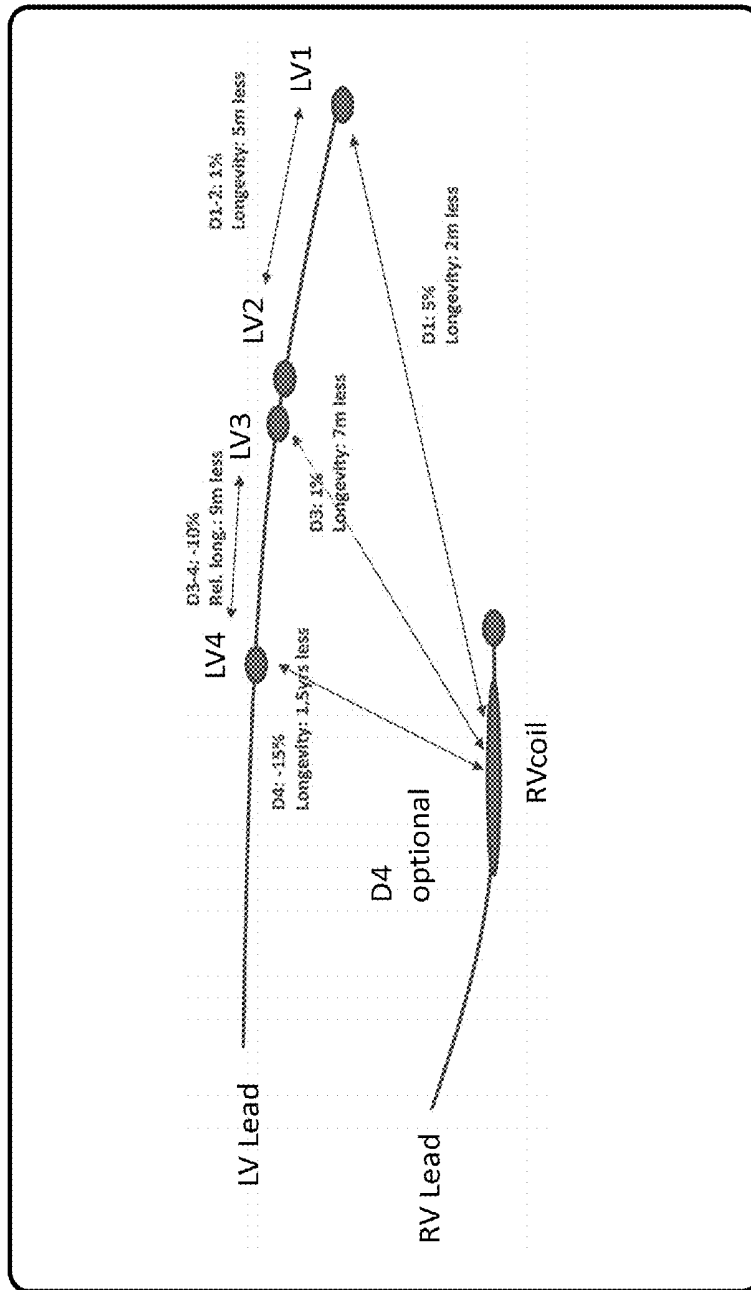

FIG. 12

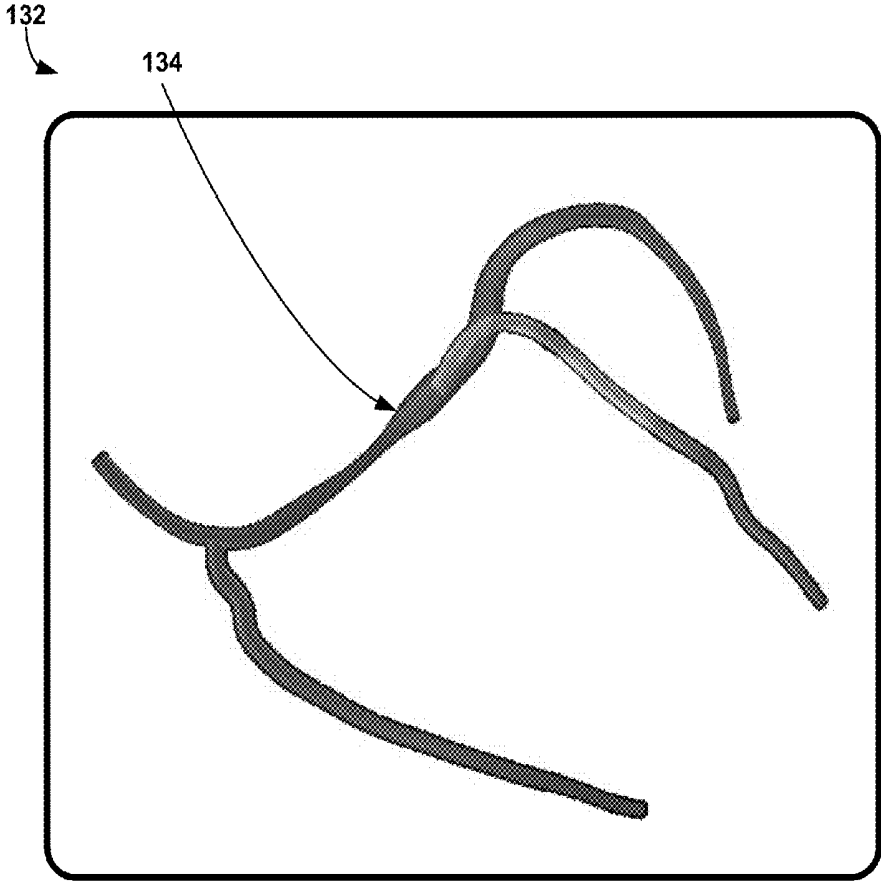
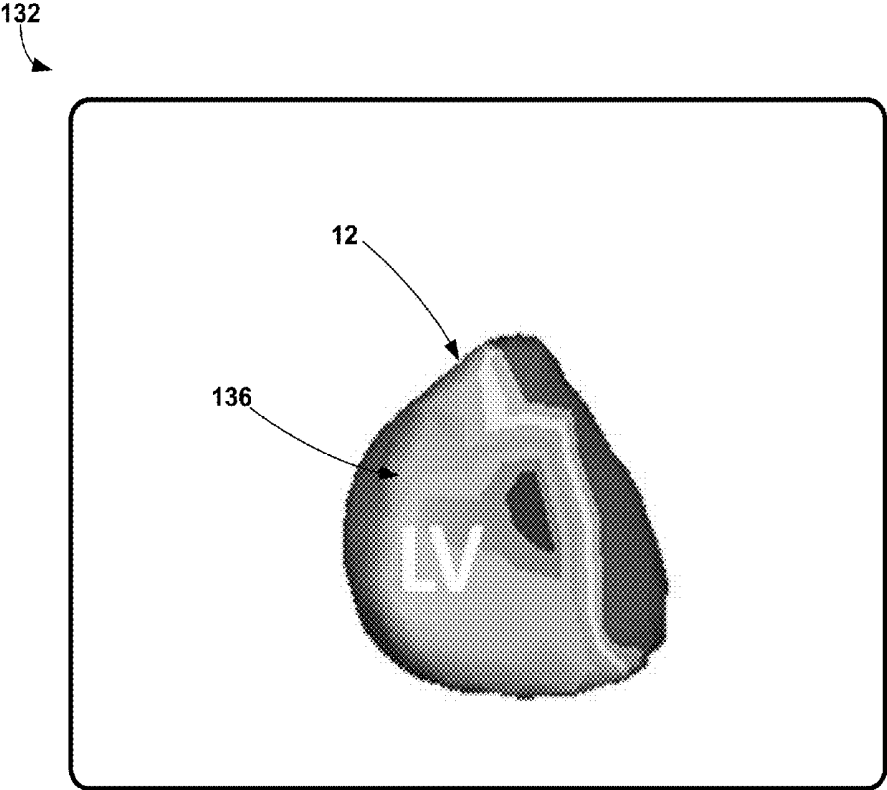

FIG. 13



SYSTEMS, METHODS, AND INTERFACES FOR IDENTIFYING OPTIMAL ELECTRICAL VECTORS

CROSS-REFERENCE TO RELATED APPLICATIONS

[0001] This application claims the benefit of U.S. Provisional Patent Application 61/913,784 entitled “Systems, Methods, and Interfaces for Identifying Optimal Electrical Vectors” and filed on Dec. 9, 2013 and U.S. Provisional Patent Application 61/817,480 entitled “Identifying Optimal Electrical Vectors” and filed on Apr. 30, 2013, each of which is incorporated herein by reference in its entirety.

BACKGROUND

[0002] The disclosure herein relates to systems, methods, and interfaces for identifying optimal electrical vectors used to deliver therapy to tissue and/or sense signals from tissue. The identified vectors may be used in systems, methods, and interfaces for navigating an implantable electrode to a region of a patient’s heart for cardiac therapy.

[0003] Electrodes may be used in various systems, apparatus, and methods for medical treatment of a patient. More specifically, electrodes may be located adjacent, or in contact, with tissue (e.g., skin, cardiac tissue, etc.) of a patient to deliver therapy to the tissue of the patient and/or sense signals from the tissue of the patient. Some electrodes may be more effective at delivering therapy than others (e.g., due to location, contact, etc.). Additionally, some of the more effective electrodes may form more effective or optimal electrical vectors for pacing than others.

SUMMARY

[0004] The exemplary systems, methods, and interfaces described herein may be configured to select one or more electrodes and/or pacing configurations based on cardiac improvement information (e.g., indicative of improvement in cardiac function) and identify one or more optimal electrical vectors that use the selected electrodes based on at least longevity information.

[0005] One exemplary system for identifying one or more optimal electrical vectors may include electrode apparatus and control apparatus. The electrode apparatus may include a plurality of electrodes (e.g., configured to pace at least one ventricle, coupled to at least one lead, etc.) configured to be located proximate tissue of a patient for pacing. The control apparatus may be coupled to the electrode apparatus and may be configured to deliver pacing therapy to the patient using each pacing configuration of a plurality of different pacing configurations, where each pacing configuration uses one or more electrodes of the plurality of electrodes to deliver electrical pacing stimulation, and to generate cardiac improvement information for each pacing configuration, where the cardiac improvement information is representative of a change in mechanical and/or electrical cardiac functionality resulting from pacing delivered using each pacing configuration. In at least one embodiment, a common anode may be used when delivering pacing therapy using each pacing configuration of the plurality of different pacing configurations to be used to generate cardiac improvement information. The cardiac improvement information may be representative of a change in mechanical and/or electrical cardiac functionality resulting from pacing delivered using each pacing configura-

tion. The control apparatus may be further configured to select one or more pacing configurations of the plurality of different pacing configurations based on the cardiac improvement information, where each of the one or more selected pacing configurations are usable with one or more other electrodes to define a plurality of electrical vectors. The control apparatus may be further configured to generate longevity information for each electrical vector of the plurality of electrical vectors and identify one or more optimal electrical vectors of the plurality of electrical vectors based on the longevity information.

[0006] One exemplary method for identifying one or more optimal electrical vectors may include delivering pacing therapy using each pacing configuration of a plurality of different pacing configurations (e.g., configured to pace at least one ventricle, coupled to at least one lead, etc.), where each pacing configuration uses one or more electrodes of a plurality of electrodes to deliver electrical pacing stimulation, and generating cardiac improvement information for each pacing configuration, where the cardiac improvement information may be representative of a change in mechanical and/or electrical cardiac functionality resulting from pacing delivered using each pacing configuration. In at least one embodiment, a common anode may be used when delivering pacing therapy using each pacing configuration of the plurality of different pacing configurations to be used to generate cardiac improvement information. The exemplary method may further include selecting one or more pacing configurations of the plurality of different pacing configurations based on the cardiac improvement information, where each of the one or more selected pacing configurations are usable with one or more other electrodes to define a plurality of electrical vectors. The exemplary method may further include generating longevity information for each electrical vector of the plurality of electrical vectors and identifying one or more optimal electrical vectors of the plurality of electrical vectors based on the longevity information.

[0007] Another exemplary system for assisting a user in implantation of an implantable electrode for cardiac therapy may include means for deliver pacing therapy using each pacing configuration of a plurality of different pacing configurations and computing means for generating cardiac improvement information for each pacing configuration (e.g., the cardiac improvement information is representative of a change in mechanical and/or electrical cardiac functionality) and for selecting one or more pacing configurations of the plurality of different pacing configurations based on the cardiac improvement information. Each of the one or more selected pacing configurations may be usable with one or more other electrodes to define a plurality of electrical vectors. The computing means may further be for generating longevity information for each electrical vector of the plurality of electrical vectors and for identifying one or more optimal electrical vectors of the plurality of electrical vectors based on the longevity information.

[0008] An exemplary system for use in cardiac therapy may include electrode apparatus (e.g., a plurality of electrodes configured to be located proximate tissue of a patient for pacing), display apparatus (e.g., including a graphical user interface configured to present information for use in assisting a user in at least one of assessing a patient’s cardiac health, evaluating and adjusting cardiac therapy delivered to a patient, and navigating at least one implantable electrode to a region of the patient’s heart, etc.), and computing apparatus

coupled to the electrode apparatus and display apparatus. The computing apparatus may be configured to deliver pacing therapy to the patient using each pacing configuration of a plurality of different pacing configurations (e.g., each pacing configuration uses one or more electrodes of the plurality of electrodes to deliver electrical pacing stimulation), generate cardiac improvement information for each pacing configuration (e.g., the cardiac improvement information is representative of a change in mechanical and/or electrical cardiac functionality resulting from pacing delivered using each pacing configuration), select one or more pacing configurations of the plurality of different pacing configurations based on the cardiac improvement information, where each of the one or more selected pacing configurations are usable with one or more other electrodes to define a plurality of electrical vectors, identify one or more optimal electrical vectors of the plurality of electrical vectors based on the longevity information, and display on the graphical user interface information for use in assisting a user in at least one of assessing a patient's cardiac health, evaluating and adjusting cardiac therapy delivered to a patient, and navigating at least one implantable electrode to a region of the patient's heart, wherein the information comprises the identified one or more optimal electrical vectors.

[0009] An exemplary method for use in cardiac therapy may include delivering pacing therapy using each pacing configuration of a plurality of different pacing configurations (e.g., configured to pace at least one ventricle, coupled to at least one lead, etc.), where each pacing configuration uses one or more electrodes of a plurality of electrodes to deliver electrical pacing stimulation, and generating cardiac improvement information for each pacing configuration, where the cardiac improvement information may be representative of a change in mechanical and/or electrical cardiac functionality resulting from pacing delivered using each pacing configuration, and selecting one or more pacing configurations of the plurality of different pacing configurations based on the cardiac improvement information, where each of the one or more selected pacing configurations are usable with one or more other electrodes to define a plurality of electrical vectors. The exemplary method may further include generating longevity information for each electrical vector of the plurality of electrical vectors, identifying one or more optimal electrical vectors of the plurality of electrical vectors based on the longevity information, displaying on a graphical user interface information for use in assisting a user in at least one of assessing a patient's cardiac health, evaluating and adjusting cardiac therapy delivered to a patient, and navigating at least one implantable electrode to a region of the patient's heart, wherein the information comprises the identified one or more optimal electrical vectors of the plurality of electrical vectors.

[0010] Another exemplary system for use in cardiac therapy may include means for deliver pacing therapy using each pacing configuration of a plurality of different pacing configurations and computing means for generating cardiac improvement information for each pacing configuration (e.g., the cardiac improvement information is representative of a change in mechanical and/or electrical cardiac functionality) and for selecting one or more pacing configurations of the plurality of different pacing configurations based on the cardiac improvement information. Each of the one or more selected pacing configurations may be usable with one or more other electrodes to define a plurality of electrical vec-

tors. The computing means may further be for generating longevity information for each electrical vector of the plurality of electrical vectors and for identifying one or more optimal electrical vectors of the plurality of electrical vectors based on the longevity information. The exemplary system may further include display means for providing a graphical user interface displaying information for use in assisting a user in at least one of assessing a patient's cardiac health, evaluating and adjusting cardiac therapy delivered to a patient, and navigating at least one implantable electrode to a region of the patient's heart, wherein the information comprises the identified one or more optimal electrical vectors of the plurality of electrical vectors.

[0011] In one or more exemplary embodiments, the graphical user interface may include the identified one or more optimal electrical vectors on the at least a portion of anatomy of the patient's heart. In one or more exemplary embodiments, one or more candidate regions proximate the patient's heart for implantation of an implantable electrode based on the identified one or more optimal electrical vectors may be determined (e.g., using computing means, computing apparatus, display means, display apparatus, etc.) and the one or more candidate site regions may be identified on the graphical user interface on the at least a portion of anatomy of the patient's heart for implantation of the implantable electrode. In at least one embodiment, the information displayed, on the graphical user interface, may include at least a portion of anatomy of the patient's heart (e.g., at least a portion of the blood vessel anatomy of the patient's heart, at least a portion of the coronary sinus, etc.).

[0012] In one or more embodiments, generating cardiac improvement information for each electrode may include generating dyssynchrony information, or measures of electrical heterogeneity, for each pacing configuration by monitoring heart function using a plurality of surface electrodes during pacing and/or using cardiac imaging apparatus during pacing.

[0013] In one or more embodiments, the dyssynchrony information may include a dyssynchrony improvement value for each pacing configuration, and the dyssynchrony improvement value may be generated by comparing baseline dyssynchrony to paced dyssynchrony during pacing using each electrode.

[0014] In one or more embodiments, selecting one or more pacing configurations based on the cardiac improvement information may include defining a threshold value based on the dyssynchrony information and selecting one or more pacing configurations having a dyssynchrony improvement value greater than the threshold value. In at least one embodiment, the threshold value may be set to a maximum generated dyssynchrony improvement value multiplied by a factor, where the factor is selected based on the maximum generated dyssynchrony improvement value.

[0015] In one or more embodiments, the control module may be further configured to execute or the method may further include delivering pacing therapy using at least one pacing configuration that uses two or more electrodes of the plurality of electrodes per cardiac cycle if the cardiac improvement information generated for each pacing configuration that uses one electrode of the plurality of electrodes does not meet a threshold criteria.

[0016] In one or more embodiments, generating longevity information for each electrical vector of the plurality of electrical vectors may include determining at least one of a cap-

ture threshold for each electrical vector and an impedance value for each electrical vector.

[0017] In one or more embodiments, the control module may be further configured to execute or the method may further include determining whether each electrical vector stimulates the phrenic nerve and identifying the one or more optimal electrical vectors of the plurality of electrical vectors based on an absence of phrenic nerve stimulation.

[0018] In one or more embodiments, identifying the one or more optimal electrical vectors of the plurality of electrical vectors based on the longevity information may include identifying the electrical vector having at least one of the greatest longevity, lowest capture threshold, and smallest impedance.

[0019] One exemplary system and/or method may involve automatically selecting an optimal pacing vector for a multipolar cardiac resynchronization therapy (CRT) lead (e.g., a left ventricular lead, a right ventricular lead, etc.). In at least one embodiment, an electrode may be automatically selected without ranking the electrodes. Once a determination is made that an electrode performs above a preselected threshold that relates to maximal improvement, the electrode may be selected. In at least one embodiment, the system and/or method may automatically weigh data related to dyssynchrony or rhythm improvement against battery longevity, capture threshold, and phrenic nerve stimulation. Based upon this data, the exemplary system and/or method may determine that equivalent electrodes exist. Electrodes may be deemed equivalent based upon certain criteria (e.g., relative improvement of cardiac dyssynchrony). Instead of re-evaluating all of the electrodes, the system and/or method may automatically eliminate certain electrodes and focus on the equivalent electrodes for any additional testing thereby reducing implant time.

[0020] After an LV lead has been placed at a target location, an exemplary method may automatically initiate a sequence of setting CRT pacing parameters from a programmer/analyzer, measure dyssynchrony, modify the CRT pacing parameters, measure dyssynchrony, and repeat until all desired configurations are measured. In at least one embodiment, the exemplary processes and/or methods may be directly integrated with an exemplary system, which could control the sequencing of changes to CRT pacing configurations, and an exemplary system (e.g., imaging system) could measure dyssynchrony (e.g., relative improvements in dyssynchrony from a given electrode compared to a baseline rhythm). The system may be further configured to recognize the displayed pacing parameters via character recognition from the video output of the programmer/analyzer.

[0021] In at least one embodiment, a fully-automated application within an exemplary system may communicate a desired sequencing of changes to CRT pacing configurations to the programmer/analyzer (via Ethernet or wireless network).

[0022] In at least one embodiment, some of the pacing parameters may be manually modified using a programmer/analyzer. An exemplary system may measure dyssynchrony and recognize displayed pacing parameters via character recognition from the video output of the programmer/analyzer.

[0023] The above summary is not intended to describe each embodiment or every implementation of the present disclosure. A more complete understanding will become apparent and appreciated by referring to the following detailed description and claims taken in conjunction with the accompanying drawings.

BRIEF DESCRIPTION OF THE DRAWINGS

[0024] FIG. 1 is a diagram of an exemplary system including an exemplary implantable medical device (IMD).

[0025] FIG. 2A is a diagram of the exemplary IMD of FIG. 1.

[0026] FIG. 2B is a diagram of an enlarged view of a distal end of the electrical lead disposed in the left ventricle of FIG. 2A.

[0027] FIG. 3A is a block diagram of an exemplary IMD, e.g., the IMD of FIGS. 1-2.

[0028] FIG. 3B is another block diagram of an exemplary IMD (e.g., an implantable pulse generator) circuitry and associated leads employed in the system of FIGS. 1-2 for providing three sensing channels and corresponding pacing channels.

[0029] FIG. 4 is a diagram of an exemplary system including electrode apparatus, imaging apparatus, display apparatus, and computing apparatus.

[0030] FIGS. 5A-5B are conceptual diagrams illustrating exemplary systems for measuring torso-surface potentials.

[0031] FIG. 6 is a block diagram of an exemplary method of identifying an optimal electrical vector.

[0032] FIG. 7 is an exemplary graphical user interface depicting a table of cardiac improvement information for a plurality of electrodes.

[0033] FIG. 8 is another exemplary graphical user interface depicting a table of cardiac improvement information for a plurality of electrodes.

[0034] FIG. 9 is an exemplary graphical user interface depicting a table of longevity information for a plurality of electrode vectors.

[0035] FIG. 10 is an exemplary graphical user interface depicting a table of longevity information, phrenic nerve stimulation, and cardiac improvement information for a plurality of electrical vectors.

[0036] FIG. 11 is an exemplary graphical user interface depicting a graphical representation of a pair of leads and cardiac improvement information and longevity information depicted proximate the electrodes of the leads.

[0037] FIG. 12 is an exemplary graphical user interface depicting blood vessel anatomy configured to assist a user in navigating an implantable electrode to a region of a patient's heart for cardiac therapy.

[0038] FIG. 13 is an exemplary graphical user interface depicting a human heart including activation times mapped thereon configured to assist a user in navigating an implantable electrode to a region of a patient's heart for cardiac therapy.

DETAILED DESCRIPTION OF EXEMPLARY EMBODIMENTS

[0039] In the following detailed description of illustrative embodiments, reference is made to the accompanying figures of the drawing which form a part hereof, and in which are shown, by way of illustration, specific embodiments which may be practiced. It is to be understood that other embodiments may be utilized and structural changes may be made without departing from (e.g., still falling within) the scope of the disclosure presented hereby.

[0040] Exemplary systems, methods, and interfaces shall be described with reference to FIGS. 1-13. It will be apparent to one skilled in the art that elements or processes from one embodiment may be used in combination with elements or

processes of the other embodiments, and that the possible embodiments of such methods, apparatus, and systems using combinations of features set forth herein is not limited to the specific embodiments shown in the Figures and/or described herein. Further, it will be recognized that the embodiments described herein may include many elements that are not necessarily shown to scale. Still further, it will be recognized that timing of the processes and the size and shape of various elements herein may be modified but still fall within the scope of the present disclosure, although certain timings, one or more shapes and/or sizes, or types of elements, may be advantageous over others.

[0041] As described herein, various exemplary systems, methods, and interfaces may utilize electrodes configured to deliver therapy to tissue of a patient and/or sense one or more signals from the tissue of the patient. For example, electrodes may be included as part of an implantable medical device (IMD) and located on one or more leads configured to be located proximate one or more portions of a patient's heart.

[0042] The exemplary methods and processes described herein may be utilized and implemented by one or more (e.g., two or more, a plurality, etc.) systems, apparatus, and devices that include and/or are coupled to at least one electrode. For example, the exemplary methods and processes may be used by an exemplary therapy system **10** described herein with reference to FIGS. **1-3** and exemplary system **100** including a spatial electrode-array as described herein with reference to FIGS. **5A-5B**. Although only therapy system **10** and sensing system **100** are described and depicted herein, it is to be understood that the exemplary methods and processes may be used by any system including computing apparatus capable of analyzing signals from one or more electrodes. The computing apparatus, for example, may be located in an external computer or programmer, may be located in an IMD, or may be located on a server attached to a network.

[0043] FIG. **1** is a conceptual diagram illustrating an exemplary therapy system **10** that may be used to deliver pacing therapy to a patient **14**. Patient **14** may, but not necessarily, be a human. The therapy system **10** may include an implantable medical device **16** (IMD), which may be coupled to leads **18, 20, 22** and/or a programmer **24**. The IMD **16** may be, e.g., an implantable pacemaker, cardioverter, and/or defibrillator, that provides electrical signals to the heart **12** of the patient **14** via electrodes coupled to one or more of the leads **18, 20, 22**.

[0044] The leads **18, 20, 22** extend into the heart **12** of the patient **14** to sense electrical activity of the heart **12** and/or to deliver electrical stimulation to the heart **12**. In the example shown in FIG. **1**, the right ventricular (RV) lead **18** extends through one or more veins (not shown), the superior vena cava (not shown), and the right atrium **26**, and into the right ventricle **28**. The left ventricular (LV) coronary sinus lead **20** extends through one or more veins, the vena cava, the right atrium **26**, and into the coronary sinus **30** to a region adjacent to the free wall of the left ventricle **32** of the heart **12**. The right atrial (RA) lead **22** extends through one or more veins and the vena cava, and into the right atrium **26** of the heart **12**.

[0045] The IMD **16** may sense, among other things, electrical signals attendant to the depolarization and repolarization of the heart **12** via electrodes coupled to at least one of the leads **18, 20, 22**. The IMD **16** may be configured to determine or identify effective electrodes located on the leads **18, 20, 22** using the exemplary methods and processes described herein. In some examples, the IMD **16** provides pacing therapy (e.g., pacing pulses) to the heart **12** based on the electrical signals

sensed within the heart **12**. The IMD **16** may be operable to adjust one or more parameters associated with the pacing therapy such as, e.g., AV delay and other various timings, pulse width, amplitude, voltage, burst length, etc. Further, the IMD **16** may be operable to use various electrode configurations to deliver pacing therapy, which may be unipolar, bipolar, quadripolar, or further multipolar. For example, a multipolar lead may include several electrodes which can be used for delivering pacing therapy. Hence, a multipolar lead system may provide, or offer, multiple electrical vectors to pace from. A pacing vector may include at least one cathode, which may be at least one electrode located on at least one lead, and at least one anode, which may be at least one electrode located on at least one lead (e.g., the same lead, or a different lead) and/or on the casing, or can, of the IMD. While improvement in cardiac function as a result of the pacing therapy may primarily depend on the cathode, the electrical parameters like impedance, pacing threshold voltage, current drain, longevity, etc. may be more dependent on the pacing vector, which includes both the cathode and the anode. The IMD **16** may also provide defibrillation therapy and/or cardioversion therapy via electrodes located on at least one of the leads **18, 20, 22**. Further, the IMD **16** may detect arrhythmia of the heart **12**, such as fibrillation of the ventricles **28, 32**, and deliver defibrillation therapy to the heart **12** in the form of electrical pulses. In some examples, IMD **16** may be programmed to deliver a progression of therapies, e.g., pulses with increasing energy levels, until a fibrillation of heart **12** is stopped.

[0046] In some examples, a programmer **24**, which may be a handheld computing device or a computer workstation, may be used by a user, such as a physician, technician, another clinician, and/or patient, to communicate with the IMD **16** (e.g., to program the IMD **16**). For example, the user may interact with the programmer **24** to retrieve information concerning cardiac improvement information (e.g., dyssynchrony information, etc.) for one or more electrodes, longevity information (e.g., capture threshold information, impedance values, etc.) with respect to one or more electrical vectors, and/or whether one or more electrical vectors stimulate the phrenic nerve. Additionally, the user may interact with the programmer **24** to selected one or more optimal electrical vectors, e.g., for use in delivering therapy. Further, the user may interact with the programmer **24** to retrieve information concerning one or more detected or indicated faults associated within the IMD **16** and/or the pacing therapy delivered therewith. For instance, computing apparatus located in one or both of the IMD **16** and the programmer **24** may be configured to analyze or evaluate signals from one or more electrodes to selected one or more electrodes and identify one or more optimal electrical vectors. The IMD **16** and the programmer **24** may communicate via wireless communication using any techniques known in the art. Examples of communication techniques may include, e.g., low frequency or radiofrequency (RF) telemetry, but other techniques are also contemplated.

[0047] FIG. **2A** is a conceptual diagram illustrating the IMD **16** and the leads **18, 20, 22** of therapy system **10** of FIG. **1** in more detail. The leads **18, 20, 22** may be electrically coupled to a therapy delivery module (e.g., for delivery of pacing therapy), a sensing module (e.g., for sensing one or more signals from one or more electrodes), and/or any other modules of the IMD **16** via a connector block **34**. In some examples, the proximal ends of the leads **18, 20, 22** may

include electrical contacts that electrically couple to respective electrical contacts within the connector block 34 of the IMD 16. In addition, in some examples, the leads 18, 20, 22 may be mechanically coupled to the connector block 34 with the aid of set screws, connection pins, or another suitable mechanical coupling mechanism.

[0048] Each of the leads 18, 20, 22 includes an elongated insulative lead body, which may carry a number of conductors (e.g., concentric coiled conductors, straight conductors, etc.) separated from one another by insulation (e.g., tubular insulative sheaths). In the illustrated example, bipolar electrodes 40, 42 are located proximate to a distal end of the lead 18. In addition, the bipolar electrodes 44, 45, 46, 47 are located proximate to a distal end of the lead 20 and the bipolar electrodes 48, 50 are located proximate to a distal end of the lead 22.

[0049] The electrodes 40, 44, 45, 46, 47, 48 may take the form of ring electrodes, and the electrodes 42, 50 may take the form of extendable helix tip electrodes mounted retractably within the insulative electrode heads 52, 54, 56, respectively. Each of the electrodes 40, 42, 44, 45, 46, 47, 48, 50 may be electrically coupled to a respective one of the conductors (e.g., coiled and/or straight) within the lead body of its associated lead 18, 20, 22, and thereby coupled to respective ones of the electrical contacts on the proximal end of the leads 18, 20, 22.

[0050] Additionally, electrodes 44, 45, 46 and 47 may have an electrode surface area of about 5.3 mm² to about 5.8 mm². Electrodes 44, 45, 46, and 47 may also referred to as LV1, LV2, LV3, and LV4, respectively. The LV electrodes (i.e., left ventricle electrode 1 (LV1) 44, left ventricle electrode 2 (LV2) 45, left ventricle electrode 3 (LV3) 46, and left ventricle 4 (LV4) 47 etc.) on the lead 20 can be spaced apart at variable distances. For example, electrode 44 may be a distance of, e.g., about 21 millimeters (mm), away from electrode 45, electrodes 45 and 46 may be spaced a distance of, e.g. about 1.3 mm to about 1.5 mm, away from each other, and electrodes 46 and 47 may be spaced a distance of, e.g. 20 mm to about 21 mm, away from each other.

[0051] The electrodes 40, 42, 44, 45, 46, 47, 48, 50 may further be used to sense electrical signals (e.g., morphological waveforms within electrograms (EGM)) attendant to the depolarization and repolarization of the heart 12. The sensed electrical signals may be used to determine which the electrodes 40, 42, 44, 45, 46, 47, 48, 50 are the most effective in improving cardiac function. The electrical signals are conducted to the IMD 16 via the respective leads 18, 20, 22. In some examples, the IMD 16 may also deliver pacing pulses via the electrodes 40, 42, 44, 45, 46, 47, 48, 50 to cause depolarization of cardiac tissue of the patient's heart 12. In some examples, as illustrated in FIG. 2A, the IMD 16 includes one or more housing electrodes, such as housing electrode 58, which may be formed integrally with an outer surface of a housing 60 (e.g., hermetically-sealed housing) of the IMD 16 or otherwise coupled to the housing 60. Any of the electrodes 40, 42, 44, 45, 46, 47, 48 and 50 may be used for unipolar sensing or pacing in combination with housing electrode 58. In other words, any of electrodes 40, 42, 44, 45, 46, 47, 48, 50, 58 may be used in combination to form a sensing vector, e.g., a sensing vector that may be used to evaluate and/or analyze the effectiveness of pacing therapy. It is generally understood by those skilled in the art that other electrodes can also be selected to define, or be used for, pacing and sensing vectors. Further, any of electrodes 40, 42, 44, 45, 46,

47, 48, 50, 58, which are not being used to deliver pacing therapy, may be used to sense electrical activity during pacing therapy.

[0052] As described in further detail with reference to FIGS. 3A-3B, the housing 60 may enclose a therapy delivery module that may include a stimulation generator for generating cardiac pacing pulses and defibrillation or cardioversion shocks, as well as a sensing module for monitoring the patient's heart rhythm. The leads 18, 20, 22 may also include elongated electrodes 62, 64, 66, respectively, which may take the form of a coil. The IMD 16 may deliver defibrillation shocks to the heart 12 via any combination of the elongated electrodes 62, 64, 66 and the housing electrode 58. The electrodes 58, 62, 64, 66 may also be used to deliver cardioversion pulses to the heart 12. Further, the electrodes 62, 64, 66 may be fabricated from any suitable electrically conductive material, such as, but not limited to, platinum, platinum alloy, and/or other materials known to be usable in implantable defibrillation electrodes. Since electrodes 62, 64, 66 are not generally configured to deliver pacing therapy, any of electrodes 62, 64, 66 may be used to sense electrical activity (e.g., for use in determining electrode effectiveness, for use in analyzing pacing therapy effectiveness, etc.) and may be used in combination with any of electrodes 40, 42, 44, 45, 46, 47, 48, 50, 58. In at least one embodiment, the RV elongated electrode 62 may be used to sense electrical activity of a patient's heart during the delivery of pacing therapy (e.g., in combination with the housing electrode 58 forming a RV elongated coil, or defibrillation electrode-to-housing electrode vector).

[0053] The configuration of the exemplary therapy system 10 illustrated in FIGS. 1-2 is merely one example. In other examples, the therapy system may include epicardial leads and/or patch electrodes instead of or in addition to the transvenous leads 18, 20, 22 illustrated in FIG. 1. Further, in one or more embodiments, the IMD 16 need not be implanted within the patient 14. For example, the IMD 16 may deliver various cardiac therapies to the heart 12 via percutaneous leads that extend through the skin of the patient 14 to a variety of positions within or outside of the heart 12. In one or more embodiments, the system 10 may utilize wireless pacing (e.g., using energy transmission to the intracardiac pacing component(s) via ultrasound, inductive coupling, RF, etc.) and sensing cardiac activation using electrodes on the can/housing and/or on subcutaneous leads.

[0054] In other examples of therapy systems that provide electrical stimulation therapy to the heart 12, such therapy systems may include any suitable number of leads coupled to the IMD 16, and each of the leads may extend to any location within or proximate to the heart 12. For example, other examples of therapy systems may include three transvenous leads located as illustrated in FIGS. 1-2. Still further, other therapy systems may include a single lead that extends from the IMD 16 into the right atrium 26 or the right ventricle 28, or two leads that extend into a respective one of the right atrium 26 and the right ventricle 28.

[0055] FIG. 3A is a functional block diagram of one exemplary configuration of the IMD 16. As shown, the IMD 16 may include a control module 81, a therapy delivery module 84 (e.g., which may include a stimulation generator), a sensing module 86, and a power source 90.

[0056] The control module 81 may include a processor 80, memory 82, and a telemetry module 88. The memory 82 may include computer-readable instructions that, when executed,

e.g., by the processor **80**, cause the IMD **16** and/or the control module **81** to perform various functions attributed to the IMD **16** and/or the control module **81** described herein. Further, the memory **82** may include any volatile, non-volatile, magnetic, optical, and/or electrical media, such as a random access memory (RAM), read-only memory (ROM), non-volatile RAM (NVRAM), electrically-erasable programmable ROM (EEPROM), flash memory, and/or any other digital media. An exemplary capture management module may be the left ventricular capture management (LVCM) module described in U.S. Pat. No. 7,684,863 entitled "LV THRESHOLD MEASUREMENT AND CAPTURE MANAGEMENT" and issued Mar. 23, 2010, which is incorporated herein by reference in its entirety.

[0057] The processor **80** of the control module **81** may include any one or more of a microprocessor, a controller, a digital signal processor (DSP), an application specific integrated circuit (ASIC), a field-programmable gate array (FPGA), and/or equivalent discrete or integrated logic circuitry. In some examples, the processor **80** may include multiple components, such as any combination of one or more microprocessors, one or more controllers, one or more DSPs, one or more ASICs, and/or one or more FPGAs, as well as other discrete or integrated logic circuitry. The functions attributed to the processor **80** herein may be embodied as software, firmware, hardware, or any combination thereof.

[0058] The control module **81** may be used to determine the effectiveness of the electrodes **40, 42, 44, 45, 46, 47, 48, 50, 58, 62, 64, 66** using the exemplary methods and/or processes described herein according to a selected one or more programs, which may be stored in the memory **82**. Further, the control module **81** may control the therapy delivery module **84** to deliver therapy (e.g., electrical stimulation therapy such as pacing) to the heart **12** according to a selected one or more therapy programs, which may be stored in the memory **82**. More, specifically, the control module **81** (e.g., the processor **80**) may control various parameters of the electrical stimulus delivered by the therapy delivery module **84** such as, e.g., AV delays, pacing pulses with the amplitudes, pulse widths, frequency, or electrode polarities, etc., which may be specified by one or more selected therapy programs (e.g., AV delay adjustment programs, pacing therapy programs, pacing recovery programs, capture management programs, etc.). As shown, the therapy delivery module **84** is electrically coupled to electrodes **40, 42, 44, 45, 46, 47, 48, 50, 58, 62, 64, 66**, e.g., via conductors of the respective lead **18, 20, 22**, or, in the case of housing electrode **58**, via an electrical conductor disposed within housing **60** of IMD **16**. Therapy delivery module **84** may be configured to generate and deliver electrical stimulation therapy such as pacing therapy to the heart **12** using one or more of the electrodes **40, 42, 44, 45, 46, 47, 48, 50, 58, 62, 64, 66**.

[0059] For example, therapy delivery module **84** may deliver pacing stimulus (e.g., pacing pulses) via ring electrodes **40, 44, 45, 46, 47, 48** coupled to leads **18, 20**, and **22**, respectively, and/or tip electrodes **42** and **50** of leads **18** and **22**. Further, for example, therapy delivery module **84** may deliver defibrillation shocks to heart **12** via at least two of electrodes **58, 62, 64, 66**. In some examples, therapy delivery module **84** may be configured to deliver pacing, cardioversion, or defibrillation stimulation in the form of electrical pulses. In other examples, therapy delivery module **84** may be configured deliver one or more of these types of stimulation in

the form of other signals, such as sine waves, square waves, and/or other substantially continuous time signals.

[0060] The IMD **16** may further include a switch module **85** and the control module **81** (e.g., the processor **80**) may use the switch module **85** to select, e.g., via a data/address bus, which of the available electrodes are used to deliver therapy such as pacing pulses for pacing therapy, or which of the available electrodes are used for sensing. The switch module **85** may include a switch array, switch matrix, multiplexer, or any other type of switching device suitable to selectively couple the sensing module **86** and/or the therapy delivery module **84** to one or more selected electrodes. More specifically, the therapy delivery module **84** may include a plurality of pacing output circuits. Each pacing output circuit of the plurality of pacing output circuits may be selectively coupled, e.g., using the switch module **85**, to one or more of the electrodes **40, 42, 44, 45, 46, 47, 48, 50, 58, 62, 64, 66** (e.g., a pair of electrodes for delivery of therapy to a pacing vector). In other words, each electrode can be selectively coupled to one of the pacing output circuits of the therapy delivery module using the switching module **85**.

[0061] The sensing module **86** is coupled (e.g., electrically coupled) to sensing apparatus, which may include, among additional sensing apparatus, the electrodes **40, 42, 44, 45, 46, 47, 48, 50, 58, 62, 64, 66** to monitor electrical activity of the heart **12**, e.g., electrocardiogram (ECG)/electrogram (EGM) signals, etc. The ECG/EGM signals may be used to identify the effectiveness of each of the electrodes **40, 42, 44, 45, 46, 47, 48, 50, 58, 62, 64, 66** (e.g., by monitoring or measuring the signals for analysis by the control module **81**, the programmer **24**, etc.). Further, the ECG/EGM signals may be used to measure or monitor activation times (e.g., ventricular activations times, etc.), heart rate (HR), heart rate variability (HRV), heart rate turbulence (HRT), deceleration/acceleration capacity, deceleration sequence incidence, T-wave alternans (TWA), P-wave to P-wave intervals (also referred to as the P-P intervals or A-A intervals), R-wave to R-wave intervals (also referred to as the R-R intervals or V-V intervals), P-wave to QRS complex intervals (also referred to as the P-R intervals, A-V intervals, or P-Q intervals), QRS-complex morphology, ST segment (i.e., the segment that connects the QRS complex and the T-wave), T-wave changes, QT intervals, electrical vectors, etc.

[0062] The switch module **85** may be also be used with the sensing module **86** to select which of the available electrodes are used, or enabled, to, e.g., sense electrical activity of the patient's heart (e.g., one or more electrical vectors of the patient's heart using any combination of the electrodes **40, 42, 44, 45, 46, 47, 48, 50, 58, 62, 64, 66**). Likewise, the switch module **85** may be also be used with the sensing module **86** to select which of the available electrodes are not to be used (e.g., disabled) to, e.g., sense electrical activity of the patient's heart (e.g., one or more electrical vectors of the patient's heart using any combination of the electrodes **40, 42, 44, 45, 46, 47, 48, 50, 58, 62, 64, 66**), etc. In some examples, the control module **81** may select the electrodes that function as sensing electrodes via the switch module within the sensing module **86**, e.g., by providing signals via a data/address bus.

[0063] In some examples, sensing module **86** includes a channel that includes an amplifier with a relatively wider pass band than the R-wave or P-wave amplifiers. Signals from the selected sensing electrodes may be provided to a multiplexer, and thereafter converted to multi-bit digital signals by an

analog-to-digital converter for storage in memory **82**, e.g., as an electrogram (EGM). In some examples, the storage of such EGMs in memory **82** may be under the control of a direct memory access circuit. The control module **81** (e.g., using the processor **80**) may employ digital signal analysis techniques to characterize the digitized signals stored in memory **82** to analyze and/or classify one or more morphological waveforms of the EGM signals to determine pacing therapy effectiveness, etc. For example, the processor **80** may be configured to determine, or obtain, one or more features of one or more sensed morphological waveforms within one of more electrical vectors of the patient's heart and store the one or more features within the memory **82** for use in comparing features, values, etc. of the waveforms to determine effectiveness of the electrodes.

[0064] In some examples, the control module **81** may operate as an interrupt driven device, and may be responsive to interrupts from pacer timing and control module, where the interrupts may correspond to the occurrences of sensed P-waves and R-waves and the generation of cardiac pacing pulses. Any necessary mathematical calculations may be performed by the processor **80** and any updating of the values or intervals controlled by the pacer timing and control module may take place following such interrupts. A portion of memory **82** may be configured as a plurality of recirculating buffers, capable of holding one or more series of measured intervals, which may be analyzed by, e.g., the processor **80** in response to the occurrence of a pace or sense interrupt to determine whether the patient's heart **12** is presently exhibiting atrial or ventricular tachyarrhythmia.

[0065] The telemetry module **88** of the control module **81** may include any suitable hardware, firmware, software, or any combination thereof for communicating with another device, such as the programmer **24** as described herein with respect to FIG. 1. For example, under the control of the processor **80**, the telemetry module **88** may receive downlink telemetry from and send uplink telemetry to the programmer **24** with the aid of an antenna, which may be internal and/or external. The processor **80** may provide the data to be uplinked to the programmer **24** and the control signals for the telemetry circuit within the telemetry module **88**, e.g., via an address/data bus. In some examples, the telemetry module **88** may provide received data to the processor **80** via a multiplexer.

[0066] The various components of the IMD **16** are further coupled to a power source **90**, which may include a rechargeable or non-rechargeable battery. A non-rechargeable battery may be selected to last for several years, while a rechargeable battery may be inductively charged from an external device, e.g., on a daily or weekly basis.

[0067] FIG. 3B is another embodiment of a functional block diagram for IMD **16**. FIG. 3B depicts bipolar RA lead **22**, bipolar RV lead **18**, and bipolar LV CS lead **20** without the LA CS pace/sense electrodes and coupled with an implantable pulse generator (IPG) circuit **31** having programmable modes and parameters of a bi-ventricular DDD/R type known in the pacing art. In turn, the sensor signal processing circuit **91** indirectly couples to the timing circuit **83** and via data and control bus to microcomputer circuitry **33**. The IPG circuit **31** is illustrated in a functional block diagram divided generally into a microcomputer circuit **33** and a pacing circuit **21**. The pacing circuit **21** includes the digital controller/timer circuit **83**, the output amplifiers circuit **51**, the sense amplifiers cir-

cuit **55**, the RF telemetry transceiver **41**, the activity sensor circuit **35** as well as a number of other circuits and components described below.

[0068] Crystal oscillator circuit **89** provides the basic timing clock for the pacing circuit **21**, while battery **29** provides power. Power-on-reset circuit **87** responds to initial connection of the circuit to the battery for defining an initial operating condition and similarly, resets the operative state of the device in response to detection of a low battery condition. Reference mode circuit **37** generates stable voltage reference and currents for the analog circuits within the pacing circuit **21**, while analog to digital converter ADC and multiplexer circuit **39** digitizes analog signals and voltage to provide real time telemetry if a cardiac signals from sense amplifiers **55**, for uplink transmission via RF transmitter and receiver circuit **41**. Voltage reference and bias circuit **37**, ADC and multiplexer **39**, power-on-reset circuit **87** and crystal oscillator circuit **89** may correspond to any of those presently used in current marketed implantable cardiac pacemakers.

[0069] If the IPG is programmed to a rate responsive mode, the signals output by one or more physiologic sensor are employed as a rate control parameter (RCP) to derive a physiologic escape interval. For example, the escape interval is adjusted proportionally to the patient's activity level developed in the patient activity sensor (PAS) circuit **35** in the depicted, exemplary IPG circuit **31**. The patient activity sensor **27** is coupled to the IPG housing and may take the form of a piezoelectric crystal transducer as is well known in the art and its output signal is processed and used as the RCP. Sensor **27** generates electrical signals in response to sensed physical activity that are processed by activity circuit **35** and provided to digital controller/timer circuit **83**. Activity circuit **35** and associated sensor **27** may correspond to the circuitry disclosed in U.S. Pat. No. 5,052,388 entitled "METHOD AND APPARATUS FOR IMPLEMENTING ACTIVITY SENSING IN A PULSE GENERATOR" and issued on Oct. 1, 1991 and U.S. Pat. No. 4,428,378 entitled "RATE ADAPTIVE PACER" and issued on Jan. 31, 1984, each of which is incorporated herein by reference in their entirety. Similarly, the exemplary systems, apparatus, and methods described herein may be practiced in conjunction with alternate types of sensors such as oxygenation sensors, pressure sensors, pH sensors and respiration sensors, all well known for use in providing rate responsive pacing capabilities. Alternately, QT time may be used as the rate indicating parameter, in which case no extra sensor is required. Similarly, the exemplary embodiments described herein may also be practiced in non-rate responsive pacemakers.

[0070] Data transmission to and from the external programmer is accomplished by way of the telemetry antenna **57** and an associated RF transceiver **41**, which serves both to demodulate received downlink telemetry and to transmit uplink telemetry. Uplink telemetry capabilities will typically include the ability to transmit stored digital information, e.g. operating modes and parameters, EGM histograms, and other events, as well as real time EGMs of atrial and/or ventricular electrical activity and marker channel pulses indicating the occurrence of sensed and paced depolarizations in the atrium and ventricle, as are well known in the pacing art.

[0071] Microcomputer **33** contains a microprocessor **80** and associated system clock and on-processor RAM and ROM chips **82A** and **82B**, respectively. In addition, microcomputer circuit **33** includes a separate RAM/ROM chip **82C** to provide additional memory capacity. Microprocessor **80**

normally operates in a reduced power consumption mode and is interrupt driven. Microprocessor **80** is awakened in response to defined interrupt events, which may include A-TRIG, RV-TRIG, LV-TRIG signals generated by timers in digital timer/controller circuit **83** and A-EVENT, RV-EVENT, and LV-EVENT signals generated by sense amplifiers circuit **55**, among others. The specific values of the intervals and delays timed out by digital controller/timer circuit **83** are controlled by the microcomputer circuit **33** by way of data and control bus from programmed-in parameter values and operating modes. In addition, if programmed to operate as a rate responsive pacemaker, a timed interrupt, e.g., every cycle or every two seconds, may be provided in order to allow the microprocessor to analyze the activity sensor data and update the basic A-A, V-A, or V-V escape interval, as applicable. In addition, the microprocessor **80** may also serve to define variable, operative AV delay intervals and the energy delivered to each ventricle.

[0072] In one embodiment, microprocessor **80** is a custom microprocessor adapted to fetch and execute instructions stored in RAM/ROM unit **82** in a conventional manner. It is contemplated, however, that other implementations may be suitable to practice the present invention. For example, an off-the-shelf, commercially available microprocessor or microcontroller, or custom application-specific, hardwired logic, or state-machine type circuit may perform the functions of microprocessor **80**.

[0073] Digital controller/timer circuit **83** operates under the general control of the microcomputer **33** to control timing and other functions within the pacing circuit **320** and includes a set of timing and associated logic circuits of which certain ones pertinent to the present invention are depicted. The depicted timing circuits include URI/LRI timers **83A**, V-V delay timer **83B**, intrinsic interval timers **83C** for timing elapsed V-EVENT to V-EVENT intervals or V-EVENT to A-EVENT intervals or the V-V conduction interval, escape interval timers **83D** for timing A-A, V-A, and/or V-V pacing escape intervals, an AV delay interval timer **83E** for timing the A-LVp delay (or A-RVp delay) from a preceding A-EVENT or A-TRIG, a post-ventricular timer **83F** for timing post-ventricular time periods, and a date/time clock **83G**.

[0074] The AV delay interval timer **83E** is loaded with an appropriate delay interval for one ventricular chamber (e.g., either an A-RVp delay or an A-LVp delay as determined using known methods) to time-out starting from a preceding A-PACE or A-EVENT. The interval timer **83E** triggers pacing stimulus delivery, and can be based on one or more prior cardiac cycles (or from a data set empirically derived for a given patient).

[0075] The post-event timer **83F** time out the post-ventricular time period following an RV-EVENT or LV-EVENT or a RV-TRIG or LV-TRIG and post-atrial time periods following an A-EVENT or A-TRIG. The durations of the post-event time periods may also be selected as programmable parameters stored in the microcomputer **33**. The post-ventricular time periods include the PVARP, a post-atrial ventricular blanking period (PAVBP), a ventricular blanking period (VBP), a post-ventricular atrial blanking period (PVARP) and a ventricular refractory period (VRP) although other periods can be suitably defined depending, at least in part, on the operative circuitry employed in the pacing engine. The post-atrial time periods include an atrial refractory period (ARP) during which an A-EVENT is ignored for the purpose of resetting any AV delay, and an atrial blanking period (ABP)

during which atrial sensing is disabled. It should be noted that the starting of the post-atrial time periods and the AV delays can be commenced substantially simultaneously with the start or end of each A-EVENT or A-TRIG or, in the latter case, upon the end of the A-PACE which may follow the A-TRIG. Similarly, the starting of the post-ventricular time periods and the V-A escape interval can be commenced substantially simultaneously with the start or end of the V-EVENT or V-TRIG or, in the latter case, upon the end of the V-PACE which may follow the V-TRIG. The microprocessor **80** also optionally calculates AV delays, post-ventricular time periods, and post-atrial time periods that vary with the sensor based escape interval established in response to the RCP(s) and/or with the intrinsic atrial rate.

[0076] The output amplifiers circuit **51** contains a RA pace pulse generator (and a LA pace pulse generator if LA pacing is provided), a RV pace pulse generator, and a LV pace pulse generator or corresponding to any of those presently employed in commercially marketed cardiac pacemakers providing atrial and ventricular pacing. In order to trigger generation of an RV-PACE or LV-PACE pulse, digital controller/timer circuit **83** generates the RV-TRIG signal at the time-out of the A-RVp delay (in the case of RV pre-excitation) or the LV-TRIG at the time-out of the A-LVp delay (in the case of LV pre-excitation) provided by AV delay interval timer **83E** (or the V-V delay timer **83B**). Similarly, digital controller/timer circuit **83** generates an RA-TRIG signal that triggers output of an RA-PACE pulse (or an LA-TRIG signal that triggers output of an LA-PACE pulse, if provided) at the end of the V-A escape interval timed by escape interval timers **83D**.

[0077] The output amplifiers circuit **51** includes switching circuits for coupling selected pace electrode pairs from among the lead conductors and the IND_CAN electrode **20** to the RA pace pulse generator (and LA pace pulse generator if provided), RV pace pulse generator and LV pace pulse generator. Pace/sense electrode pair selection and control circuit **53** selects lead conductors and associated pace electrode pairs to be coupled with the atrial and ventricular output amplifiers within output amplifiers circuit **51** for accomplishing RA, LA, RV and LV pacing.

[0078] The sense amplifiers circuit **55** contains sense amplifiers corresponding to any of those presently employed in contemporary cardiac pacemakers for atrial and ventricular pacing and sensing. High impedance P-wave and R-wave sense amplifiers may be used to amplify a voltage difference signal that is generated across the sense electrode pairs by the passage of cardiac depolarization wavefronts. The high impedance sense amplifiers use high gain to amplify the low amplitude signals and rely on pass band filters, time domain filtering and amplitude threshold comparison to discriminate a P-wave or R-wave from background electrical noise. Digital controller/timer circuit **83** controls sensitivity settings of the atrial and ventricular sense amplifiers **55**.

[0079] The sense amplifiers are typically uncoupled from the sense electrodes during the blanking periods before, during, and after delivery of a pace pulse to any of the pace electrodes of the pacing system to avoid saturation of the sense amplifiers. The sense amplifiers circuit **55** includes blanking circuits for uncoupling the selected pairs of the lead conductors and the IND-CAN electrode **20** from the inputs of the RA sense amplifier (and LA sense amplifier if provided), RV sense amplifier and LV sense amplifier during the ABP, PVABP and VBP. The sense amplifiers circuit **55** also

includes switching circuits for coupling selected sense electrode lead conductors and the IND-CAN electrode **20** to the RA sense amplifier (and LA sense amplifier if provided), RV sense amplifier and LV sense amplifier. Again, sense electrode selection and control circuit **53** selects conductors and associated sense electrode pairs to be coupled with the atrial and ventricular sense amplifiers within the output amplifiers circuit **51** and sense amplifiers circuit **55** for accomplishing RA, LA, RV and LV sensing along desired unipolar and bipolar sensing vectors.

[0080] Right atrial depolarizations or P-waves in the RA-SENSE signal that are sensed by the RA sense amplifier result in a RA-EVENT signal that is communicated to the digital controller/timer circuit **83**. Similarly, left atrial depolarizations or P-waves in the LA-SENSE signal that are sensed by the LA sense amplifier, if provided, result in a LA-EVENT signal that is communicated to the digital controller/timer circuit **83**. Ventricular depolarizations or R-waves in the RV-SENSE signal are sensed by a ventricular sense amplifier result in an RV-EVENT signal that is communicated to the digital controller/timer circuit **83**. Similarly, ventricular depolarizations or R-waves in the LV-SENSE signal are sensed by a ventricular sense amplifier result in an LV-EVENT signal that is communicated to the digital controller/timer circuit **83**. The RV-EVENT, LV-EVENT, and RA-EVENT, LA-SENSE signals may be refractory or non-refractory, and can inadvertently be triggered by electrical noise signals or aberrantly conducted depolarization waves rather than true R-waves or P-waves.

[0081] As described herein, various exemplary systems, methods, and interfaces may be configured to use electrode apparatus including external electrodes, imaging apparatus, display apparatus, and computing apparatus to noninvasively assist a user (e.g., a physician) in selecting one or more locations (e.g., implantation site regions) proximate a patient's heart for one or more implantable electrodes and/or to navigate one or more implantable electrodes to the selected location(s). An exemplary system **100** including electrode apparatus **110**, imaging apparatus **120**, display apparatus **130**, and computing apparatus **140** is depicted in FIG. 4.

[0082] The electrode apparatus **110** as shown includes a plurality of electrodes incorporated, or included within a band wrapped around the chest, or torso, of a patient **14**. The electrode apparatus **110** is operatively coupled to the computing apparatus **140** (e.g., through one or more wired electrical connections, wirelessly, etc.) to provide electrical signals from each of the electrodes to the computing apparatus **140** for analysis. Exemplary electrode apparatus may be described in U.S. Provisional Patent Application entitled "Bioelectric Sensor Device and Methods" and filed on Dec. 9, 2013 and U.S. patent application entitled "Bioelectric Sensor Device and Methods" and filed on even date herewith (Docket No. C00006744.USU2 (134.0793 0101)), each of which is incorporated herein by reference in its entirety. Further, exemplary electrode apparatus **110** will be described in more detail in reference to FIGS. 5A-5B.

[0083] The imaging apparatus **120** may be any type of imaging apparatus configured to image, or provide images of, at least a portion of the patient in a non-invasive manner. For example, the imaging apparatus **120** may not use any components or parts that may be located within the patient to provide images of at least a portion of the patient except non-invasive tools such as contrast solution. It is to be understood that the exemplary systems, methods, and interfaces

described herein may noninvasively assist a user (e.g., a physician) in selecting a location proximate a patient's heart for an implantable electrode, and after the exemplary systems, methods, and interfaces have provided noninvasive assistance, the exemplary systems, methods, and interfaces may then provide assistance to implant, or navigate, an implantable electrode into the patient, e.g., proximate the patient's heart.

[0084] For example, after the exemplary systems, methods, and interfaces have provided noninvasive assistance, the exemplary systems, methods, and interfaces may then provide image guided navigation that may be used to navigate leads including electrodes, leadless electrodes, wireless electrodes, catheters, etc., within the patient's body. Further, although the exemplary systems, methods, and interfaces are described herein with reference to a patient's heart, it is to be understood that the exemplary systems, methods, and interfaces may be applicable to any other portion of the patient's body.

[0085] The imaging apparatus **120** may be configured to capture, or take, x-ray images (e.g., two dimensional x-ray images, three dimensional x-ray images, etc.) of the patient **14**. The imaging apparatus **120** may be operatively coupled (e.g., through one or more wired electrical connections, wirelessly, etc.) to the computing apparatus **140** such that the images captured by the imaging apparatus **120** may be transmitted to the computing apparatus **140**. Further, the computing apparatus **140** may be configured to control the imaging apparatus **120** to, e.g., configure the imaging apparatus **120** to capture images, change one or more settings of the imaging apparatus **120**, etc.

[0086] It will be recognized that while the imaging apparatus **120** as shown in FIG. 4 may be configured to capture x-ray images, any other alternative imaging modality may also be used by the exemplary systems, methods, and interfaces described herein. For example, the imaging apparatus **120** may be configured to capture images, or image data, using isocentric fluoroscopy, bi-plane fluoroscopy, ultrasound, computed tomography (CT), multi-slice computed tomography (MSCT), magnetic resonance imaging (MRI), high frequency ultrasound (HIFU), optical coherence tomography (OCT), intra-vascular ultrasound (IVUS), two dimensional (2D) ultrasound, three dimensional (3D) ultrasound, four dimensional (4D) ultrasound, intraoperative CT, intraoperative MRI, etc. Further, it is to be understood that the imaging apparatus **120** may be configured to capture a plurality of consecutive images (e.g., continuously) to provide video frame data. In other words, a plurality of images taken over time using the imaging apparatus **120** may provide motion picture data. Additionally, the images may also be obtained and displayed in two, three, or four dimensions. In more advanced forms, four-dimensional surface rendering of the heart or other regions of the body may also be achieved by incorporating heart data or other soft tissue data from an atlas map or from pre-operative image data captured by MRI, CT, or echocardiography modalities. Image datasets from hybrid modalities, such as positron emission tomography (PET) combined with CT, or single photon emission computer tomography (SPECT) combined with CT, could also provide functional image data superimposed onto anatomical data to be used to confidently reach target locations within the heart or other areas of interest.

[0087] The display apparatus **130** and the computing apparatus **140** may be configured to display and analyze data such

as, e.g., surrogate electrical activation data, image data, mechanical motion data, etc. gathered, or collected, using the electrode apparatus 110 and the imaging apparatus 120 to noninvasively assist a user in location selection of an implantable electrode. In at least one embodiment, the computing apparatus 140 may be a server, a personal computer, or a tablet computer. The computing apparatus 140 may be configured to receive input from input apparatus 142 and transmit output to the display apparatus 130. Further, the computing apparatus 140 may include data storage that may allow for access to processing programs or routines and/or one or more other types of data, e.g., for driving a graphical user interface configured to noninvasively assist a user in location selection of an implantable electrode, etc.

[0088] The computing apparatus 140 may be operatively coupled to the input apparatus 142 and the display apparatus 130 to, e.g., transmit data to and from each of the input apparatus 142 and the display apparatus 130. For example, the computing apparatus 140 may be electrically coupled to each of the input apparatus 142 and the display apparatus 130 using, e.g., analog electrical connections, digital electrical connections, wireless connections, bus-based connections, network-based connections, internet-based connections, etc. As described further herein, a user may provide input to the input apparatus 142 to manipulate, or modify, one or more graphical depictions displayed on the display apparatus 130 to view and/or select one or more target or candidate locations of a portion of a patient's heart as further described herein.

[0089] Although as depicted the input apparatus 142 is a keyboard, it is to be understood that the input apparatus 142 may include any apparatus capable of providing input to the computing apparatus 140 to perform the functionality, methods, and/or logic described herein. For example, the input apparatus 142 may include a mouse, a trackball, a touchscreen (e.g., capacitive touchscreen, a resistive touchscreen, a multi-touch touchscreen, etc.), etc. Likewise, the display apparatus 130 may include any apparatus capable of displaying information to a user, such as a graphical user interface 132 including graphical depictions of anatomy of a patient's heart, images of a patient's heart, graphical depictions of locations of one or more electrodes, graphical depictions of one or more target or candidate locations, alphanumeric representations of one or more values, graphical depictions or actual images of implanted electrodes and/or leads, etc. For example, the display apparatus 130 may include a liquid crystal display, an organic light-emitting diode screen, a touchscreen, a cathode ray tube display, etc.

[0090] The graphical user interfaces 132 displayed by the display apparatus 130 may include, or display, one or more regions used to display graphical depictions, to display images, to allow selection of one or more regions or areas of such graphical depictions and images, etc. As used herein, a "region" of a graphical user interface 132 may be defined as a portion of the graphical user interface 132 within which information may be displayed or functionality may be performed. Regions may exist within other regions, which may be displayed separately or simultaneously. For example, smaller regions may be located within larger regions, regions may be located side-by-side, etc. Additionally, as used herein, an "area" of a graphical user interface 132 may be defined as a portion of the graphical user interface 132 located with a region that is smaller than the region it is located within. Exemplary systems and interfaces may be described in U.S. Provisional Patent Application 61/913,743 entitled "Nonin-

vasive Cardiac Therapy Evaluation" and filed on Dec. 9, 2013 and U.S. patent application entitled "Noninvasive Cardiac Therapy Evaluation" and filed on even date herewith (Docket No. C00006745.USU2 (134.0794 0101)), each of which is incorporated herein by reference in its entirety.

[0091] The processing programs or routines stored and/or executed by the computing apparatus 140 may include programs or routines for computational mathematics, matrix mathematics, decomposition algorithms, compression algorithms (e.g., data compression algorithms), calibration algorithms, image construction algorithms, signal processing algorithms (e.g., Fourier transforms, fast Fourier transforms, etc.), standardization algorithms, comparison algorithms, vector mathematics, or any other processing required to implement one or more exemplary methods and/or processes described herein. Data stored and/or used by the computing apparatus 140 may include, for example, image data from the imaging apparatus 120, electrical signal data from the electrode apparatus 110, graphics (e.g., graphical elements, icons, buttons, windows, dialogs, pull-down menus, graphic areas, graphic regions, 3D graphics, etc.), graphical user interfaces, results from one or more processing programs or routines employed according to the disclosure herein, or any other data that may be necessary for carrying out the one and/or more processes or methods described herein.

[0092] In one or more embodiments, the exemplary systems, methods, and interfaces may be implemented using one or more computer programs executed on programmable computers, such as computers that include, for example, processing capabilities, data storage (e.g., volatile or non-volatile memory and/or storage elements), input devices, and output devices. Program code and/or logic described herein may be applied to input data to perform functionality described herein and generate desired output information. The output information may be applied as input to one or more other devices and/or methods as described herein or as would be applied in a known fashion.

[0093] The one or more programs used to implement the systems, methods, and/or interfaces described herein may be provided using any programmable language, e.g., a high level procedural and/or object orientated programming language that is suitable for communicating with a computer system. Any such programs may, for example, be stored on any suitable device, e.g., a storage media, that is readable by a general or special purpose program running on a computer system (e.g., including processing apparatus) for configuring and operating the computer system when the suitable device is read for performing the procedures described herein. In other words, at least in one embodiment, the exemplary systems, methods, and/or interfaces may be implemented using a computer readable storage medium, configured with a computer program, where the storage medium so configured causes the computer to operate in a specific and predefined manner to perform functions described herein. Further, in at least one embodiment, the exemplary systems, methods, and/or interfaces may be described as being implemented by logic (e.g., object code) encoded in one or more non-transitory media that includes code for execution and, when executed by a processor, is operable to perform operations such as the methods, processes, and/or functionality described herein.

[0094] The computing apparatus 140 may be, for example, any fixed or mobile computer system (e.g., a controller, a microcontroller, a personal computer, mini computer, tablet computer, etc.). The exact configuration of the computing

apparatus **130** is not limiting, and essentially any device capable of providing suitable computing capabilities and control capabilities (e.g., graphics processing, etc.) may be used. As described herein, a digital file may be any medium (e.g., volatile or non-volatile memory, a CD-ROM, a punch card, magnetic recordable tape, etc.) containing digital bits (e.g., encoded in binary, trinary, etc.) that may be readable and/or writeable by computing apparatus **140** described herein. Also, as described herein, a file in user-readable format may be any representation of data (e.g., ASCII text, binary numbers, hexadecimal numbers, decimal numbers, graphically, etc.) presentable on any medium (e.g., paper, a display, etc.) readable and/or understandable by a user.

[0095] In view of the above, it will be readily apparent that the functionality as described in one or more embodiments according to the present disclosure may be implemented in any manner as would be known to one skilled in the art. As such, the computer language, the computer system, or any other software/hardware which is to be used to implement the processes described herein shall not be limiting on the scope of the systems, processes or programs (e.g., the functionality provided by such systems, processes or programs) described herein.

[0096] FIGS. 5A-5B are conceptual diagrams illustrating exemplary electrode systems for measuring body-surface potentials and, more particularly, torso-surface potentials. The exemplary electrode systems in FIGS. 5A-5B may be configured to measure cardiac improvement information during pacing using one or more pacing electrodes. As shown in FIG. 5A, the exemplary system **110** includes a set, or array, of electrodes **102**, a strap **104**, interface/amplifier circuitry **103**, and computing apparatus **106**. The electrodes **102** are attached, or coupled, to the strap **104** and the strap **104** is configured to be wrapped around the torso of patient such that the electrodes **102** surround the patient's heart. As further illustrated, the electrodes **102** may be positioned around the circumference of patient, including the posterior, lateral, and anterior surfaces of the torso of patient. In other examples, electrodes **102** may be positioned on any one or more of the posterior, lateral, and anterior surfaces of the torso. Further, the electrodes **102** may be electrically connected to interface/amplifier circuitry **103** via wired connection **108**. The interface/amplifier circuitry **103** may be configured to amplify the signals from the electrodes **102** and provide the signals to the computing apparatus **140** such as described herein with reference to FIG. 4. Other exemplary systems may use a wireless connection to transmit the signals sensed by electrodes **102** to the interface/amplifier circuitry **103** and, in turn, the computing apparatus **140**, e.g., as channels of data.

[0097] Although in the example of FIG. 5A the electrode system **110** includes a strap **104**, in other examples any of a variety of mechanisms, e.g., tape or adhesives, may be employed to aid in the spacing and placement of electrodes **102**. In some examples, the strap **104** may include an elastic band, strip of tape, or cloth. In other examples, the electrodes **102** may be placed individually on the torso of a patient. Further, in other examples, electrodes **102** (e.g., arranged in an array) may be part of, or located within, patches, vests, and/or other means of securing the electrodes **102** to the torso of the patient.

[0098] The electrodes **102** may be configured to surround the heart of the patient and record, or monitor, the electrical signals associated with the depolarization repolarization of the heart after the signals have propagated through the torso

of patient. Each of the electrodes **102** may be used in a unipolar configuration to sense the torso-surface potentials that reflect the cardiac signals. The interface/amplifier circuitry **103** may also be coupled to a return or indifferent electrode (not shown) which may be used in combination with each of electrodes **102** for unipolar sensing. In some examples, there may be about 12 to about 50 electrodes **102** spatially distributed around the torso of patient. Other configurations may have more or fewer electrodes **102**.

[0099] The computing apparatus **140** may record and analyze the torso-surface potential signals sensed by electrodes **102** and amplified/conditioned by the interface/amplifier circuitry **103**. The computing apparatus **140** may be configured to analyze the signals from the electrodes **102** to generate cardiac improvement information (e.g., provide dyssynchrony information, dyssynchrony index, etc.) usable to determine whether pacing electrodes improve cardiac functionality. Additionally, the computing apparatus **140** may be configured to provide an output to a user indicating electrical dyssynchrony in the heart of a patient. Exemplary systems and/or methods may use the cardiac functionality improvement information (e.g., dyssynchrony information) to determine whether one or more electrodes are effective for use in pacing therapy.

[0100] In some examples, the analysis of improvement in cardiac functionality by the computing apparatus **140** may take into consideration the location of electrodes lead electrodes implanted proximate cardiac tissue (e.g., electrodes located on leads implanted in the patient's heart) and/or additional tracking points based on anatomic fiducial elements or intracardiac catheters placed proximate cardiac tissue. In such examples, the computing apparatus **140** may be communicatively coupled to an imaging device **120** as shown in FIG. 4, which may provide an image that allows the computing apparatus **140** to determine coordinate locations of each of the electrodes and/or other anatomic fiducial elements or intracardiac catheters. The imaging device **120** may be configured to monitor movement of the one or more visible electrodes to provide cardiac improvement information (e.g., dyssynchrony information).

[0101] FIG. 5B illustrates another exemplary electrode system **111** that includes a plurality of electrodes **112** configured to surround the heart of the patient and record, or monitor, the electrical signals associated with the depolarization and repolarization of the heart after the signals have propagated through the torso of patient. The electrode system **110** may include a vest **114** upon which the plurality of electrodes is attached, or to which they are coupled. In at least one embodiment, the plurality, or array, of electrodes **112** may be used to provide cardiac improvement information (e.g., dyssynchrony information). Similar to the electrode system **110**, the electrode system **111** may include interface/amplifier circuitry **113** electrically coupled to each of the electrodes **112** through a wired connection **118** and configured to transmit signals from the electrodes **112** to a computing apparatus **140**. As illustrated, the electrodes **112** may be distributed over the torso of patient, including, for example, the anterior, lateral, and posterior surfaces of the torso of patient.

[0102] The vest **114** may be formed of fabric, or any other material, with the electrodes **112** attached thereon. The vest **114** may be configured to maintain the position and spacing of electrodes **112** on the torso of the patient. Further, the vest **114** may be marked to assist in determining the location of the electrodes **112** on the surface of the torso of the patient. In

some examples, there may be about 25 to about 256 electrodes **112** distributed around the torso of the patient, though other configurations may have more or fewer electrodes **112**.

[0103] The exemplary systems, apparatus, methods, and/or interfaces described herein are configured to identify one or more optimal electrical vectors for delivering cardiac therapy, and the systems including electrodes and computing apparatus described herein with reference to FIGS. **1-5** may utilize the exemplary systems, apparatus, methods, and/or interfaces. More specifically, the exemplary systems, apparatus, methods, and/or interfaces may be used to determine which electrical vectors defined by one or more electrodes in the systems of FIGS. **1-5** may be optimal for delivering pacing therapy to tissue of the patient and/or to assist a user in navigating, or locating, one or more electrodes to deliver pacing to the tissue of the patient about the optimal electrical vectors.

[0104] For example, when the leads **18, 20, 22** of the system **10** of FIGS. **1-3** are located, or implanted, in a patient's heart, a plurality of different electrical vectors for delivering cardiac therapy be defined by the electrodes **40, 42, 44, 45, 46, 47, 48, 50, 58, 62, 64, 66**. As such, the exemplary systems, apparatus, methods, and/or interfaces may be used with the system **10** of FIGS. **1-3** to determine which electrodes **40, 42, 44, 45, 46, 47, 48, 50, 58, 62, 64, 66** and which electrical vectors defined by the electrodes **40, 42, 44, 45, 46, 47, 48, 50, 58, 62, 64, 66** may be optimal for delivering effective electrical therapy to the cardiac tissue of the patient.

[0105] An exemplary method **150** for identifying one or more optimal electrical vectors is depicted in FIG. **6**. The method **150** includes delivering pacing therapy **152** using a plurality of electrodes in a plurality of different pacing configurations. The pacing therapy **152** may utilize one or more electrodes such as the electrodes **40, 42, 44, 45, 46, 47, 48, 50, 58, 62, 64, 66** of the system **10**. For example, each electrode (e.g., as a cathode) may be used individually to deliver pacing therapy (e.g., using the same or a different anode). In other words, one electrode at a time may be used to deliver pacing therapy. Further, for example, more than one electrode (e.g., two electrodes, three electrodes, etc.) may be used simultaneously to deliver pacing therapy. In at least one embodiment, more than one electrode (e.g., two electrodes, three electrodes, etc.) may be used simultaneously to deliver pacing therapy (e.g., if none of the electrodes used individually achieves capture, if none of the electrodes used individually provides cardiac improvement (e.g., significant cardiac improvement, sufficient cardiac improvement, etc.), etc.). In other words, more than one electrode at a time may be used to deliver pacing therapy. Additionally, one or more pacing electrodes may deliver more than one pacing pulse (e.g., each pacing pulse having a selected pacing width, each pacing pulse separated by a selected separation time period, etc.) if, e.g., none of the electrodes used individually achieves capture, if none of the electrodes used individually provides cardiac improvement (e.g., significant cardiac improvement, sufficient cardiac improvement, etc.).

[0106] In essence, the exemplary method **150** may deliver pacing therapy using a plurality of different pacing configurations using the plurality of electrodes. In some embodiments, a common anode may be used for each different pacing configuration. In other embodiments, each different pacing configuration may use a different anode.

[0107] For each different pacing configuration, the method **150** may generate cardiac improvement information **154**. The

cardiac improvement information may be defined as information that is representative of a change in mechanical and/or electrical cardiac functionality resulting from pacing. In other words, the cardiac improvement information may be indicative of improvement of cardiac functionality from baseline cardiac functionality. The baseline cardiac functionality may be cardiac functionality without any pacing therapy being delivered to the patient.

[0108] In one or more embodiments, the cardiac improvement information may include dyssynchrony information. The dyssynchrony information may also be referred to as measures of electrical heterogeneity. Dyssynchrony information may be defined as information indicative of the mechanical and/or electrical dyssynchrony of the heart. In at least one embodiment, the dyssynchrony information may include a standard deviation of ventricular activation times corresponding to electrodes on the surface array. Further, regional dyssynchrony may be also computed from the standard deviation of activation times corresponding to electrodes located in certain anatomic areas of the torso, for e.g. electrodes on the left side of the torso would be used to compute regional LV dyssynchrony. The dyssynchrony information may be generated using one or more various systems and/or methods. Dyssynchrony information may be generated using an array, or a plurality, of surface electrodes and/or imaging systems as described in U.S. Pat. App. Pub. No. 2012/0283587 A1 published Nov. 8, 2012 and entitled "ASSESSING INTRA-CARDIAC ACTIVATION PATTERNS AND ELECTRICAL DYSSYNCHRONY," U.S. Pat. App. Pub. No. 2012/0284003 A1 published Nov. 8, 2012 and entitled "ASSESSING INTRA-CARDIAC ACTIVATION PATTERNS", and U.S. Pat. No. 8,180,428 B2 issued May 15, 2012 and entitled "METHODS AND SYSTEMS FOR USE IN SELECTING CARDIAC PACING SITES," each of which is incorporated herein by reference in its entirety.

[0109] Dyssynchrony information may include one or more dyssynchrony indices. For example, one of the indices of electrical dyssynchrony may be a standard deviation index computed as the standard deviation of the activations-times (SDAT) of some or all of the electrodes on the surface of the torso of patient. In some examples, the SDAT may be calculated using the estimated cardiac activation times over the surface of a model heart.

[0110] A second example index of dyssynchrony may be a range of activation times (RAT) which may be computed as the difference between the maximum and the minimum torso-surface or cardiac activation times, e.g., overall, or for a region. The RAT reflects the span of activation times while the SDAT gives an estimate of the dispersion of the activation times from a mean. The SDAT also provides an estimate of the heterogeneity of the activation times, because if activation times are spatially heterogeneous, the individual activation times will be further away from the mean activation time, indicating that one or more regions of heart have been delayed in activation. In some examples, the RAT may be calculated using the estimated cardiac activation times over the surface of a model heart.

[0111] A third example index of electrical dyssynchrony estimates the percentage of surface electrodes located within a particular region of interest for the torso or heart, whose associated activation times are greater than a certain percentile, for example the 70th percentile, of measured QRS complex duration or the determined activation times for surface electrodes. The region of interest may be a posterior, left

anterior, and/or left-ventricular region, as examples. This index, the percentage of late activation (PLAT), provides an estimate of percentage of the region of interest, e.g., posterior and left-anterior area associated with the left ventricular area of heart, which activates late. A large value for PLAT may imply delayed activation of a substantial portion of the region, e.g., the left ventricle, and the potential benefit of electrical resynchronization through CRT by pre-exciting the late region, e.g., of left ventricle. In other examples, the PLAT may be determined for other subsets of electrodes in other regions, such as a right anterior region to evaluate delayed activation in the right ventricle. Furthermore, in some examples, the PLAT may be calculated using the estimated cardiac activation times over the surface of a model heart for either the whole heart or for a particular region, e.g., left or right ventricle, of the heart.

[0112] In one or more embodiments, the cardiac improvement information may include indicators of favorable changes in global cardiac electrical activation such as, e.g., described in Sweeney et al., "Analysis of Ventricular Activation Using Surface Electrocardiography to Predict Left Ventricular Reverse Volumetric Remodeling During Cardiac Resynchronization Therapy," *Circulation*, 2010 Feb. 9, 121 (5): 626-34 and/or Van Deursen, et al., "Vectorcardiography as a Tool for Easy Optimization of Cardiac Resynchronization Therapy in Canine LBBB Hearts," *Circulation Arrhythmia and Electrophysiology*, 2012 Jun. 1, 5(3): 544-52, each of which is incorporated herein by reference in its entirety. Cardiac improvement information may also include measurements of improved cardiac mechanical function measured by imaging or other systems to track motion of implanted leads within the heart as, e.g., described in Ryu et al., "Simultaneous Electrical and Mechanical Mapping Using 3D Cardiac Mapping System: Novel Approach for Optimal Cardiac Resynchronization Therapy," *Journal of Cardiovascular Electrophysiology*, 2010 February, 21(2): 219-22, Sperzel et al., "Intraoperative Characterization of Interventricular Mechanical Dyssynchrony Using Electroanatomic Mapping System—A Feasibility Study," *Journal of Interventional Cardiac Electrophysiology*, 2012 November, 35(2): 189-96, and/or U.S. Pat. App. Pub. No. 2009/0099619 A1 entitled "METHOD FOR OPTIMIZING CRT THERAPY" and published on Apr. 16, 2009, each of which is incorporated herein by reference in its entirety.

[0113] In one or more embodiments, the cardiac improvement information may be generated by tracking lead motion and inter-electrode distances with fluoroscopy to generate at least one metric (e.g., value(s), functions, comparisons, differences, averages, slopes, etc.) that correlates with cardiac contractility. For example, a contractility curve may be generated based on the variation in distance between the RV and LV electrode-tips during the course of one or more cardiac cycles and one or more metrics relating to fractional shortening may be derived from this curve. In another embodiment, multiple points on intracardiac leads and/or catheter systems may be tracked during course of one or more cardiac cycles to generate metrics relating to contractility or global cardiac mechanical dyssynchrony.

[0114] In at least one embodiment, a computing apparatus such as the computing apparatus 140 described herein with reference to FIG. 4 may be used to measure a dyssynchrony index during intrinsic rhythm and during pacing with each pacing configuration or electrode to generate cardiac functionality information used to select one or more pacing con-

figurations or electrodes to be possibly used in one or more optimal pacing vectors. For example, a physician may place a LV lead in a target location and a user may initiate CRT pacing from the programmer/analyzer. For each of a plurality of CRT pacing configurations, the system may be configured to detect the pacing parameters displayed on the programmer/analyzer screen (e.g., using character recognition from VGA output), and then, the system may measure a dyssynchrony index. The CRT pacing configurations may be automatically, or manually, changed on a programmer/analyzer. Then, the system may classify each of the electrodes, or electrode configurations, as one of "improved," "neutral," or "worsened" using the dyssynchrony measurements.

[0115] In at least one embodiment, changes in dyssynchrony during CRT pacing may be measured from each LV electrode as the cathode at a common A-V delay (e.g., less than 60 milliseconds from the intrinsic AV time) ensuring sufficient energy for cathode capture and/or to avoid fusion of the pacing depolarization with the intrinsic depolarization. Further, a common anode may be selected for these preliminary evaluations such as, e.g., a RV coil. Cathode capture can be verified by morphology of a LV cathode to RV coil electrocardiogram.

[0116] In at least one embodiment, if poor dyssynchrony is measured, the exemplary method may switch to higher amplitudes to encourage some anodal capture and/or switch to multi-site pacing (e.g., pacing using more than one electrode) to, e.g., see if dyssynchrony improves.

[0117] Based on the cardiac improvement information, the method 150 may select one or more electrodes 156. To select the one or more pacing configurations, the cardiac improvement information may provide one or more numerical metrics or values (e.g., value(s), functions, differences, comparisons, averages, slopes, etc.) that may be compared against each other and/or one or more threshold values. The pacing configurations having the best cardiac improvement information and/or metrics or values exceeding selected thresholds may be selected to be used in, or defining, one or more (e.g., one, two or more, a plurality, etc.) different pacing vectors.

[0118] For example, dyssynchrony information may include a dyssynchrony improvement value for each pacing configuration. The dyssynchrony improvement value may be generated by monitoring the dyssynchrony of the patient's heart without resynchronization pacing therapy to establish a baseline, monitoring the dyssynchrony of the patient's heart during pacing using each electrode (or electrode configuration), and comparing the baseline dyssynchrony to the dyssynchrony during resynchronization pacing to provide a dyssynchrony improvement value for each electrode (or electrode configuration). In at least one embodiment, the dyssynchrony improvement value for each pacing configuration may be compared to a threshold value and each pacing configuration exceeding the threshold value may be selected.

[0119] The dyssynchrony improvement values themselves may assist in defining, or selecting the threshold value. Generally, the threshold may be defined as a decreasing function of the maximal dyssynchrony improvement value (e.g., maximal relative improvement in resynchronization). More specifically, the threshold value may be calculated by multiplying a factor by the maximal, or maximum, dyssynchrony improvement value.

[0120] Further, the factor used to calculate the threshold value may be selected based on the maximum generated dyssynchrony improvement value. In at least one embodi-

ment, if a maximal dyssynchrony improvement value, or maximal relative improvement in resynchronization value, is between 0% and 5%, then the factor may be set of 0.9. If the maximal dyssynchrony improvement value is between 5% and 10%, then the factor may be set to 0.8. If the maximal dyssynchrony improvement value is between 10% and 25%, then the factor may be set to 0.75. If the maximal dyssynchrony improvement value is above 25%, then the factor may be set to 0.7. A threshold for a maximal dyssynchrony improvement value means that all pacing configurations and/or electrodes with a resynchronization efficacy greater than the threshold multiplied by the maximal dyssynchrony improvement value should be selected (e.g., selected to be possibly used in one or more optimal pacing vectors).

[0121] The one or more pacing configurations and/or electrodes selected based on the cardiac improvement information **156** may define, or be used to form, one or more electrical vectors configured to deliver therapy to the patient's heart. For example, if a first left ventricular electrode and a second left ventricular electrode are selected based on the cardiac improvement information, one or more electrical vectors may be defined between the first left ventricular electrode and one or all of the remaining electrodes and one or more electrical vectors may be defined between the second left ventricular electrode and one or all of the remaining electrodes.

[0122] In other words, the selection of one or more pacing configurations and/or electrodes based on the cardiac improvement information **156** may provide one or more electrical vectors that may be used to deliver therapy. To determine whether the one or more electrical vectors are optimal, the method **150** may take into consideration information such as longevity information for each electrical vector **158**, whether the electrical vector stimulates the phrenic nerve, etc.

[0123] For example, generated longevity information **158** may include an energy expenditure value for each electrical vector, which can be determined based on a capture threshold for each electrical vector, an impedance value for each electrical vector, a pulse width for each electrical vector (e.g., required for capture), information regarding each pacing pulse for multi-site pacing configurations, etc. Energy expenditure may be expressed in actual or relative estimated energy usage or actual or relative predicted battery longevity when an IMD operates using a particular parameter selection.

[0124] One or more processes and/or methods disclosed in U.S. Pat. App. Pub. No. 2012/0101543 A1 filed on Oct. 21, 2010 and entitled "CAPTURE THRESHOLD MEASUREMENT FOR SELECTION OF PACING VECTOR," U.S. Pat. App. Pub. No. 2012/0101546 A1 filed on Jul. 29, 2011 and entitled "METHOD AND APPARATUS TO DETERMINE THE RELATIVE ENERGY EXPENDITURE FOR A PLURALITY OF PACING VECTORS," U.S. Pat. App. Pub. No. 2013/0030491 A1 filed on Jul. 28, 2011 and entitled "METHOD FOR DISCRIMINATING ANODAL AND CATHODAL CAPTURE," and U.S. patent application Ser. No. 13/790,683 filed on Mar. 8, 2013 and entitled "CAPTURE THRESHOLD MEASUREMENT FOR SELECTION OF PACING VECTOR" (Attorney Docket No.: C00002602.USU2), each of which is incorporated herein by reference in its entirety, may be implemented to provide cardiac improvement information such as longevity information, capture thresholds, impedance, etc. for one or more selected electrical vectors.

[0125] After longevity information has been generated for each electrical vector **158**, the method **150** may identify one or more optimal electrical vectors based on the longevity information **160**. For example, the method **150** may identify the optimal electrical vectors and automatically configure the pacing system to use the optimal electrical vectors for pacing. Further, for example, the method **150** may generate a graphical user interface **132** depicting each of the selected electrical vectors and their associated longevity information, e.g., as shown in FIG. 11. Further, the method **150** may identify the selected electrical vectors having optimal longevity information on the graphical user interface **132**, e.g., by highlighting, circles, arrows, etc. (e.g., as shown in FIG. 9).

[0126] In one or more embodiments, the method **150** may identify the most optimal electrical vector, e.g., by identifying the electrical vector having one or more of the greatest longevity, lowest capture threshold, smallest impedance, etc.

[0127] Additionally, whether the one or more selected electrical vectors stimulate the phrenic nerve may be used to identify the one or more optimal electrical vectors. For example, the method **150** may include determining whether each electrical vector stimulates the phrenic nerve and identifying the optimal electrical vector of the plurality of electrical vectors based on an absence of phrenic nerve stimulation.

[0128] One or more processes and/or methods disclosed in U.S. Pat. App. Pub. No. 2012/0296388 A1 filed on May 17, 2012 and entitled "PHRENIC NERVE STIMULATION DETECTION USING HEART SOUNDS," U.S. Pat. App. Pub. No. 2012/0296387 A1 filed on Nov. 22, 2012 and entitled "PHRENIC NERVE STIMULATION DETECTION USING HEART SOUNDS," U.S. Pat. No. 8,295,943 B2 issued on Oct. 23, 2012 and entitled "IMPLANTABLE MEDICAL LEAD WITH BIASED ELECTRODE," and U.S. Pat. App. Pub. No. 2009/0054941 A1 filed on Aug. 20, 2008 and entitled "STIMULATION FIELD MANAGEMENT," each of which is incorporated herein by reference in their entirety, may be implemented to provide phrenic nerve stimulation information (e.g., for use in determining whether one or more electrical vectors stimulate the phrenic nerve).

[0129] After the method **150** has identified one or more optimal electrical vectors based on the longevity information **160**, the method **150** may further **162** allow a user (e.g., physician) to navigate, or locate, one or more electrodes **162** (e.g., implantable electrodes on one or more leads, wireless/leadless electrodes, etc.) to one or more regions proximate a patient's heart to provide pacing therapy, e.g., using the one or more identified optimal electrical vectors **160**. For example, a graphical user interface **132**, such as shown in FIG. 11 described further herein, may include a graphical depiction and/or actual imaging (e.g., using imaging apparatus **120** of FIG. 4) of a patient's heart in conjunction with the identified one or more optimal pacing vectors. Using the graphical user interface **132**, a user may navigate, or locate, the one or more electrodes in the desired locations based on the identified optimal electrical vectors **160**.

[0130] Exemplary systems, methods, apparatus, and interfaces for electrode location selection and implantation may be described in U.S. patent application Ser. No. 13/916,353 filed on Jun. 12, 2013 and entitled "Implantable Electrode Location Selection," U.S. patent application Ser. No. 13/916,377 filed on Jun. 12, 2013 and entitled "Implantable Electrode Location Selection," U.S. Provisional Patent Application No. 61/817,483 filed on Apr. 30, 2013 and entitled "Identifying Effective Electrodes," U.S. Provisional Patent

Application 61/913,795 entitled “Systems, Methods, and Interfaces for Identifying Effective Electrodes” and filed on Dec. 9, 2013, and U.S. patent application entitled “Systems, Methods, and Interfaces for Identifying Effective Electrodes” and filed on even date herewith (Docket No. C00002332, USU3 (134.0737 0101)), each of which is incorporated herein by reference in its entirety.

[0131] Exemplary graphical user interfaces **132** including displays and tables used and/or generated by the exemplary methods and/or systems described herein for identifying one or more optimal electrical vectors are shown in FIGS. 7-11. As shown in FIG. 7, cardiac improvement information has been generated for four different left ventricular electrodes (LV 1, LV2, LV3, LV4). Since the maximal improvement is 5% in this example, the factor for generating the threshold value may be set to 0.9 so all electrodes with relative improvement greater than or equal to 0.9 multiplied by 5% (i.e., the maximal improvement) may be considered equivalent/effective, and thus, may be considered as the cathode for optimal vector selection. In this example, only LV 1 has a relative improvement greater than or equal to 4.5. For lower relative improvements (e.g., 0% to 5%) as depicted in FIG. 6, the factor for generating the threshold for equivalence should be high (e.g., 0.9).

[0132] As shown in the exemplary graphical user interface **132** of FIG. 8, cardiac improvement information has been again generated for four different left ventricular electrodes (LV1, LV2, LV3, LV4). Since maximal improvement is 40%, the factor for generating the threshold may be set to 0.7 so all electrodes with relative improvement greater than or equal to 0.7 multiplied by 40% (i.e., the maximal improvement) may be considered equivalent/effective, and thus, may be considered as the cathode for optimal vector selection. In this exemplary, two electrodes, LV2 and LV3, have a relative improvement greater than or equal to 28%. For larger improvements (e.g., greater than 28%) as depicted in FIG. 7, the factor for generating the threshold for equivalence can be more relaxed (e.g., 0.7).

[0133] Longevity information may be generated for all possible vectors with the selected electrodes, LV2 and LV3, of FIG. 7 as cathodes, and may be presented in the exemplary graphical interface **132** depicting a table as shown in FIG. 9. As shown, vectors LV2-LV3 and LV2-LV4 are indicated as having maximum relative longevity. Additionally, phrenic nerve stimulation information is depicted in the table of FIG. 9.

[0134] Vector LV2-LV3 may be determined as being the most optimal vector based on the longevity information and the phrenic nerve stimulation information (e.g., such as stimulation being absent). As shown in FIG. 9, an indication **172** (i.e., an oval) may be depicted on a graphical user interface used to select electrical vectors to indicate the most optimal electrical vector.

[0135] Although not shown, all vectors corresponding to the chosen LV cathodes and which do not have associated phrenic nerve stimulation may be sorted in descending order of longevity (e.g., max longevity at the top) to make the selection convenient. In this example, the system may automatically select or the implanter or physician may select LV2-LV3 as the pacing vector to be used for pacing therapy.

[0136] An exemplary graphical user interface **132** depicting a table of longevity information, phrenic nerve stimulation, and cardiac improvement information for a plurality of electrical vectors is shown in FIG. 10. In this example, the

cardiac improvement information is displayed simultaneously with the longevity information and phrenic nerve stimulation information. As shown, the LV3-LV4 vector may be identified as being the most optimal electrical vector because, e.g., electrode LV3 provided a change in dyssynchrony index of -10% (e.g., an improvement of 10%) and the relative longevity has been determined to be 9 months less than a maximum longevity. Although the dyssynchrony index is indicated as a negative value (i.e., -10%) when indicating an improvement and a positive value when indicating a worsened condition, it to be understood that the dyssynchrony index may be indicated as positive value when indicating an improvement and a negative value when indicating a worsened condition.

[0137] An exemplary graphical user interface **132** including a graphical representation of a pair of leads, a LV lead and a RV lead, is depicted in FIG. 11, which define the electrode vectors shown and described with respect to FIG. 10. Although not shown, the graphical user interface of FIG. 11 may further include the table of FIG. 10, e.g., to display information to a physician, to allow a physician to select one or more optimal vectors, to identify the one or more optimal vectors graphically, etc. As shown, cardiac improvement information and longevity information are depicted proximate the electrical vectors defined by the electrodes of the leads.

[0138] Generally, any factor (e.g., cardiac improvement information, longevity information, phrenic nerve stimulation information, etc.) alone or in combination may be used to identify one or more optimal electrical vectors. For example, dyssynchrony information may be used in combination with phrenic nerve stimulation information, dyssynchrony information may be used in combination with longevity information, longevity information may be used alone, dyssynchrony information may be used alone, etc.

[0139] The graphical user interfaces **132** described herein with reference to FIGS. 7-11 may be provided to users such as physicians to assist them in determining which of the optimal electrical vectors to use for pacing therapy and/or navigating one or more electrodes (e.g., implantable electrodes on one or more leads) to one or more regions of a patient's heart to perform pacing at the optimal electrical vectors.

[0140] An exemplary graphical user interface **132** including blood vessel anatomy **134** of a patient's heart is shown in FIG. 12 that may be used by a user to navigate an implantable electrode to a region of the patient's heart. The blood vessel anatomy as well as other data such as mechanical motion information, etc. of the heart may be captured using the imaging apparatus **120** described herein, which may be configured to image at least a portion of blood vessel anatomy of the patient's heart and provide image data used by the computing apparatus **140** to provide mechanical motion information or data. The data or information depicted on the blood vessel anatomy of the patient's heart in FIG. 12 may be further monitored, or gathered, using the electrode apparatus **110** described herein.

[0141] A user may view and/or use the graphical user interface **132** of FIG. 12 to determine, or identify, one or more candidate site regions of the displayed portion region of the patient's heart for implantation of implantable electrodes. For example, a user may view mechanical motion information, e.g., grey-scaling or color-coding applied to the blood vessel anatomy in FIG. 12, and identify a candidate site region of the patient's heart based on the mechanical motion information.

For example, a user may identify one or more regions having, e.g., mechanical motion times greater than a threshold, having the longest mechanical motion time, etc.

[0142] Another exemplary graphical user interface 132 including a graphical depiction of a patient's heart 12 is shown in FIG. 13 that may be used by a user to navigate an implantable electrode to a region of the patient's heart. More specifically, a posterior side of a human heart 12 is depicted in the graphical user interface 132 of FIG. 13 with surrogate electrical activation times 136 color-coded, or gray-scaled, across the surface of the heart 12. As used herein, surrogate electrical activation data (e.g., surrogate electrical activation times, surrogate electrical activation time maps, etc.) may be defined as data representative of actual, or local, electrical activation data of one or more regions of the patient's heart. For example, electrical signals measured at the left anterior surface location of a patient's torso may be representative, or surrogates, of electrical signals of the left anterior left ventricle region of the patient's heart, electrical signals measured at the left lateral surface location of a patient's torso may be representative, or surrogates, of electrical signals of the left lateral left ventricle region of the patient's heart, electrical signals measured at the left posterolateral surface location of a patient's torso may be representative, or surrogates, of electrical signals of the posterolateral left ventricle region of the patient's heart, and electrical signals measured at the posterior surface location of a patient's torso may be representative, or surrogates, of electrical signals of the posterior left ventricle region of the patient's heart.

[0143] As shown, the posterolateral left ventricle region shows late activation (e.g., about 150 milliseconds). In other embodiments, both a posterior and anterior side of a human heart may be graphically depicted and overlaid with electrical activation information. The data or information depicted on the patient's heart 12 in FIG. 13 may be further monitored, or gathered, using the electrode apparatus 110 described herein.

[0144] The techniques described in this disclosure, including those attributed to the IMD 16, the programmer 24, the computing apparatus 140, and/or various constituent components, may be implemented, at least in part, in hardware, software, firmware, or any combination thereof. For example, various aspects of the techniques may be implemented within one or more processors, including one or more microprocessors, DSPs, ASICs, FPGAs, or any other equivalent integrated or discrete logic circuitry, as well as any combinations of such components, embodied in programmers, such as physician or patient programmers, stimulators, image processing devices, or other devices. The term "module," "processor," or "processing circuitry" may generally refer to any of the foregoing logic circuitry, alone or in combination with other logic circuitry, or any other equivalent circuitry.

[0145] Such hardware, software, and/or firmware may be implemented within the same device or within separate devices to support the various operations and functions described in this disclosure. In addition, any of the described units, modules, or components may be implemented together or separately as discrete but interoperable logic devices. Depiction of different features as modules or units is intended to highlight different functional aspects and does not necessarily imply that such modules or units must be realized by separate hardware or software components. Rather, functionality associated with one or more modules or units may be

performed by separate hardware or software components, or integrated within common or separate hardware or software components.

[0146] When implemented in software, the functionality ascribed to the systems, devices and techniques described in this disclosure may be embodied as instructions on a computer-readable medium such as RAM, ROM, NVRAM, EEPROM, FLASH memory, magnetic data storage media, optical data storage media, or the like. The instructions may be executed by one or more processors to support one or more aspects of the functionality described in this disclosure.

[0147] This disclosure has been provided with reference to illustrative embodiments and is not meant to be construed in a limiting sense. As described previously, one skilled in the art will recognize that other various illustrative applications may use the techniques as described herein to take advantage of the beneficial characteristics of the apparatus and methods described herein. Various modifications of the illustrative embodiments, as well as additional embodiments of the disclosure, will be apparent upon reference to this description.

What is claimed:

1. A system for use in cardiac therapy comprising:
 - electrode apparatus comprising a plurality of electrodes configured to be located proximate tissue of a patient for pacing;
 - display apparatus comprising a graphical user interface, wherein the graphical user interface is configured to present information for use in assisting a user in at least one of assessing a patient's cardiac health, evaluating and adjusting cardiac therapy delivered to a patient, and navigating at least one implantable electrode to a region of the patient's heart; and
 - computing apparatus coupled to the electrode apparatus and display apparatus and configured to:
 - deliver pacing therapy to the patient using each pacing configuration of a plurality of different pacing configurations, wherein each pacing configuration uses one or more electrodes of the plurality of electrodes to deliver electrical pacing stimulation,
 - generate cardiac improvement information for each pacing configuration, wherein the cardiac improvement information is representative of a change in mechanical and/or electrical cardiac functionality resulting from pacing delivered using each pacing configuration,
 - select one or more pacing configurations of the plurality of different pacing configurations based on the cardiac improvement information, wherein each of the one or more selected pacing configurations are usable with one or more other electrodes to define a plurality of electrical vectors,
 - generate longevity information for each electrical vector of the plurality of electrical vectors,
 - identify one or more optimal electrical vectors of the plurality of electrical vectors based on the longevity information, and
 - display, on the graphical user interface, information for use in assisting a user in at least one of assessing a patient's cardiac health, evaluating and adjusting cardiac therapy delivered to a patient, and navigating at least one implantable electrode to a region of the patient's heart, wherein the information comprises the identified one or more optimal electrical vectors.

2. The system of claim 1, wherein the electrode apparatus further comprises at least one lead, wherein the plurality of electrodes are coupled to the at least one lead.

3. The system of claim 1, wherein a common anode is used when delivering pacing therapy using each pacing configuration of the plurality of different pacing configurations to be used to generate cardiac improvement information.

4. The system of claim 1, wherein generating cardiac improvement information for each pacing configuration comprises generating dyssynchrony information for each pacing configuration by monitoring heart function using at least one of a plurality of surface electrodes during pacing and cardiac imaging apparatus during pacing.

5. The system of claim 4, wherein the dyssynchrony information comprises a dyssynchrony improvement value for each pacing configuration, wherein the dyssynchrony improvement value is generated by comparing baseline dyssynchrony to paced dyssynchrony during pacing using each pacing configuration.

6. The system of claim 4, wherein selecting one or more pacing configurations based on the cardiac improvement information comprises:

defining a threshold value based on the dyssynchrony information; and

selecting one or more pacing configurations having a dyssynchrony improvement value greater than the threshold value.

7. The system of claim 1, wherein the control module is further configured to deliver pacing therapy using at least one pacing configuration that uses two or more electrodes of the plurality of electrodes per cardiac cycle if the cardiac improvement information generated for each pacing configuration that uses one electrode of the plurality of electrodes does not meet a threshold criteria.

8. The system of claim 1, wherein generating longevity information for each electrical vector of the plurality of electrical vectors comprises determining at least one of a capture threshold for each electrical vector and an impedance value for each electrical vector.

9. The system of claim 1, wherein the control module is further configured to:

determine whether each electrical vector stimulates the phrenic nerve; and

identify the one or more optimal electrical vectors of the plurality of electrical vectors based on an absence of phrenic nerve stimulation.

10. The system of claim 1, wherein identifying the one or more optimal electrical vectors of the plurality of electrical vectors based on the longevity information comprises identifying the electrical vector having at least one of the greatest longevity, lowest capture threshold, and smallest impedance.

11. The system of claim 1, wherein the computing apparatus is further configured to execute identify, on the graphical user interface, the identified one or more optimal electrical vectors on a graphical depiction of at least a portion of anatomy of the patient's heart.

12. The system of claim 1, wherein the computing apparatus is further configured to:

determine one or more candidate regions proximate the patient's heart for implantation of an implantable electrode based on the identified one or more optimal electrical vectors; and

identify, on the graphical user interface, the one or more candidate site regions on a graphical depiction of at least

a portion of anatomy of the patient's heart for implantation of the implantable electrode.

13. A method for use in cardiac therapy comprising:

delivering pacing therapy using each pacing configuration of a plurality of different pacing configurations, wherein each pacing configuration uses one or more electrodes of a plurality of electrodes to deliver electrical pacing stimulation;

generating cardiac improvement information for each pacing configuration, wherein the cardiac improvement information is representative of a change in mechanical and/or electrical cardiac functionality resulting from pacing delivered using each pacing configuration;

selecting one or more pacing configurations of the plurality of different pacing configurations based on the cardiac improvement information, wherein each of the one or more selected pacing configurations are usable with one or more other electrodes to define a plurality of electrical vectors;

generating longevity information for each electrical vector of the plurality of electrical vectors;

identifying one or more optimal electrical vectors of the plurality of electrical vectors based on the longevity information; and

displaying, on the graphical user interface, information for use in assisting a user in at least one of assessing a patient's cardiac health, evaluating and adjusting cardiac therapy delivered to a patient, and navigating at least one implantable electrode to a region of the patient's heart, wherein the information comprises the identified one or more optimal electrical vectors.

14. The method of claim 13, wherein the electrode apparatus further comprises at least one lead, wherein the plurality of electrodes are coupled to the at least one lead.

15. The method of claim 13, wherein a common anode is used when delivering pacing therapy using each pacing configuration of the plurality of different pacing configurations to be used to generate cardiac improvement information.

16. The method of claim 13, wherein generating cardiac improvement information for each pacing configuration comprises generating dyssynchrony information for each pacing configuration by monitoring heart function using at least one of a plurality of surface electrodes during pacing and cardiac imaging apparatus during pacing.

17. The method of claim 16, wherein the dyssynchrony information comprises a dyssynchrony improvement value for each pacing configuration, wherein the dyssynchrony improvement value is generated by comparing baseline dyssynchrony to paced dyssynchrony during pacing using each pacing configuration.

18. The method of claim 16, wherein selecting one or more pacing configurations based on the cardiac improvement information comprises:

defining a threshold value based on the dyssynchrony information; and

selecting one or more pacing configurations having a dyssynchrony improvement value greater than the threshold value.

19. The method of claim 13, wherein the method further comprises delivering pacing therapy using at least one pacing configuration that uses two or more electrodes of the plurality of electrodes per cardiac cycle if the cardiac improvement

information generated for each pacing configuration that uses one electrode of the plurality of electrodes does not meet a threshold criteria.

20. The method of claim **13**, wherein generating longevity information for each electrical vector of the plurality of electrical vectors comprises determining at least one of a capture threshold for each electrical vector and an impedance value for each electrical vector.

21. The method of claim **13**, wherein the method further comprises:

determining whether each electrical vector stimulates the phrenic nerve; and

identifying the one or more optimal electrical vectors of the plurality of electrical vectors based on an absence of phrenic nerve stimulation.

22. The method of claim **13**, wherein identifying the one or more optimal electrical vectors of the plurality of electrical vectors based on the longevity information comprises identifying the electrical vector having at least one of the greatest longevity, lowest capture threshold, and smallest impedance.

23. The method of claim **13**, wherein the method further comprises identifying, on the graphical user interface, the identified one or more optimal electrical vectors on a graphical depiction of at least a portion of anatomy of the patient's heart.

24. The method of claim **13**, wherein the method further comprises:

determining one or more candidate regions proximate the patient's heart for implantation of an implantable electrode based on the identified one or more optimal electrical vectors; and

identifying, on the graphical user interface, the one or more candidate site regions on a graphical depiction of at least a portion of anatomy of the patient's heart for implantation of the implantable electrode.

25. A system for use in cardiac therapy comprising:
means for deliver pacing therapy using each pacing configuration of a plurality of different pacing configurations, wherein each pacing configuration uses one or more electrodes of a plurality of electrodes to deliver electrical pacing stimulation;

computing means for generating cardiac improvement information for each pacing configuration, wherein the cardiac improvement information is representative of a change in mechanical and/or electrical cardiac functionality resulting from pacing delivered using each pacing configuration, for selecting one or more pacing configurations of the plurality of different pacing configurations based on the cardiac improvement information, wherein each of the one or more selected pacing configurations are usable with one or more other electrodes to define a plurality of electrical vectors, for generating longevity information for each electrical vector of the plurality of electrical vectors, for identifying one or more optimal electrical vectors of the plurality of electrical vectors based on the longevity information; and

display means for providing a graphical user interface information for use in assisting a user in at least one of assessing a patient's cardiac health, evaluating and adjusting cardiac therapy delivered to a patient, and navigating at least one implantable electrode to a region of the patient's heart, wherein the information comprises the identified one or more optimal electrical vectors.

* * * * *

专利名称(译)	用于识别最佳电矢量的系统，方法和接口		
公开(公告)号	US20140323882A1	公开(公告)日	2014-10-30
申请号	US14/227919	申请日	2014-03-27
[标]申请(专利权)人(译)	美敦力公司		
申请(专利权)人(译)	美敦力公司，INC.		
当前申请(专利权)人(译)	美敦力公司，INC.		
[标]发明人	GHOSH SUBHAM GILLBERG JEFFREY JUSTEN MANFRED SCHILING ERIC		
发明人	GHOSH, SUBHAM GILLBERG, JEFFREY JUSTEN, MANFRED SCHILING, ERIC		
IPC分类号	A61B5/044 A61B5/0205 A61B5/00 A61N1/365		
CPC分类号	A61B5/044 A61N1/365 A61B5/4029 A61B5/0205 A61N1/36585 A61N1/3686 A61N1/371 A61N1/37247		
优先权	61/817480 2013-04-30 US 61/913784 2013-12-09 US		
其他公开文献	US10064567		
外部链接	Espacenet USPTO		

摘要(译)

本文描述了用于识别最佳电矢量的系统，方法和图形用户界面，所述最佳电矢量用于帮助用户植入可用于心脏治疗的可植入电极。可以为每个起搏配置生成心脏改善信息，并且可以基于心脏改善信息选择一个或多个起搏配置。可以使用针对每个电矢量生成的寿命信息来识别使用所选择的起搏配置的最佳电矢量。然后可以植入电极以用于心脏治疗以形成最佳电矢量。

