



(19) **United States**
(12) **Patent Application Publication**
Dunki-Jacobs et al.

(10) **Pub. No.: US 2014/0275748 A1**
(43) **Pub. Date: Sep. 18, 2014**

(54) **MEAL DETECTION DEVICES AND METHODS**

Publication Classification

(71) Applicant: **ETHICON ENDO-SURGERY INC., (US)**

(51) **Int. Cl.**
A61B 5/00 (2006.01)
A61F 5/00 (2006.01)

(72) Inventors: **Adam Dunki-Jacobs**, Cincinnati, OH (US); **Jason L. Harris**, Mason, OH (US); **Mathieu Lemay**, Bern (CH); **Martin Pfeleiderer**, Auvernier (CH); **Martin Proença**, Marly (CH); **Thierry Utard**, Neuchatel (CH)

(52) **U.S. Cl.**
CPC *A61B 5/4839* (2013.01); *A61F 5/0026* (2013.01); *A61F 5/005* (2013.01)
USPC **600/37**; 607/62; 604/66

(21) Appl. No.: **13/802,089**

(57) **ABSTRACT**

Devices and methods for detecting meal intake are disclosed herein. In some embodiments, one or more sensors can be used to detect or monitor physiological parameters of a user (e.g., heart rate, body movements, temperature, pH, impedance, gastric stretch, sound emissions, and the like). The outputs of the sensors can be received by a computer system configured to analyze the sensor data and make a determination as to whether meal intake has occurred or is presently occurring. The computer system's determination can be used to trigger, modulate, or otherwise control one or more therapeutic devices. Other types of devices can also be controlled using this determination, such as monitoring or logging devices.

(22) Filed: **Mar. 13, 2013**

Related U.S. Application Data

(60) Provisional application No. 61/780,013, filed on Mar. 13, 2013.

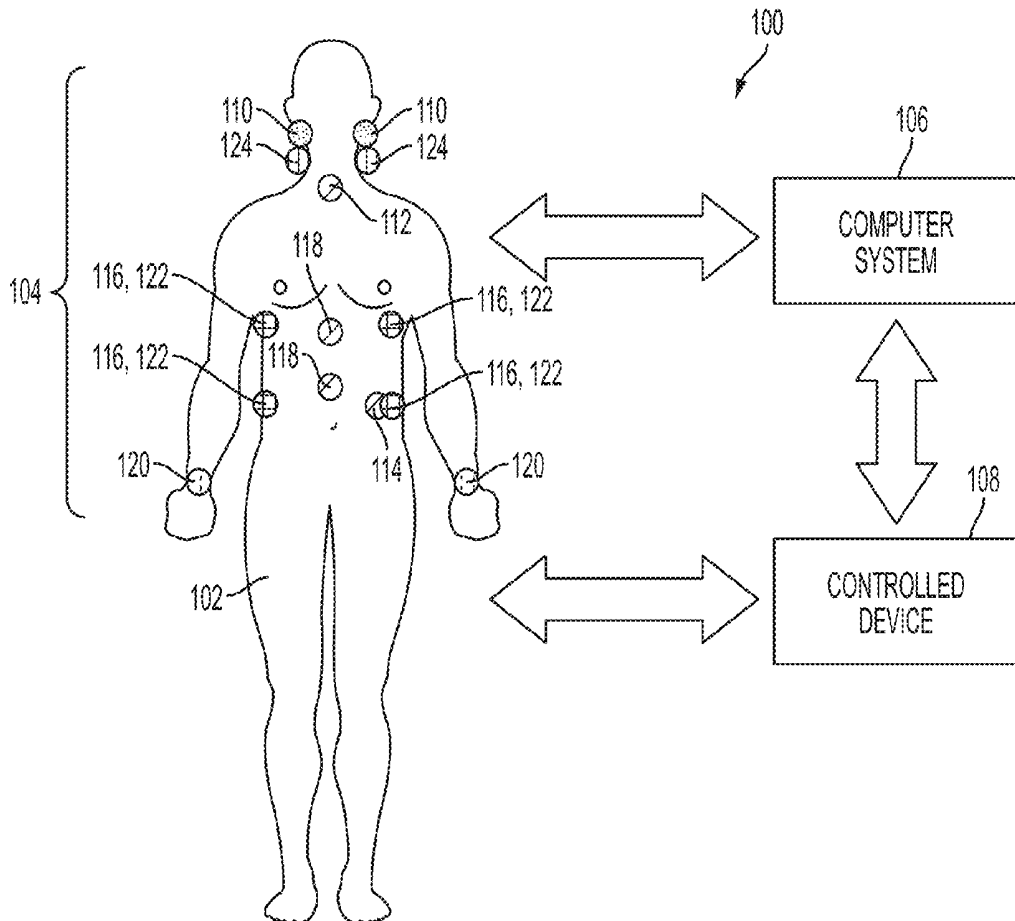

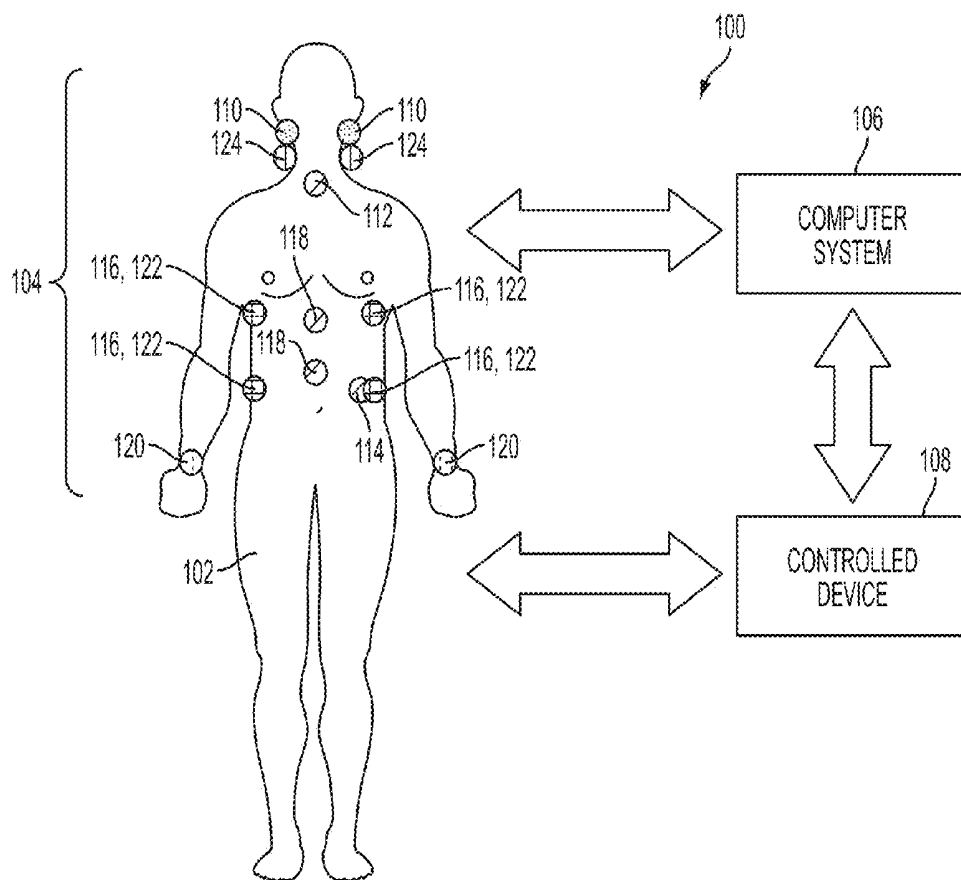

FIG. 1

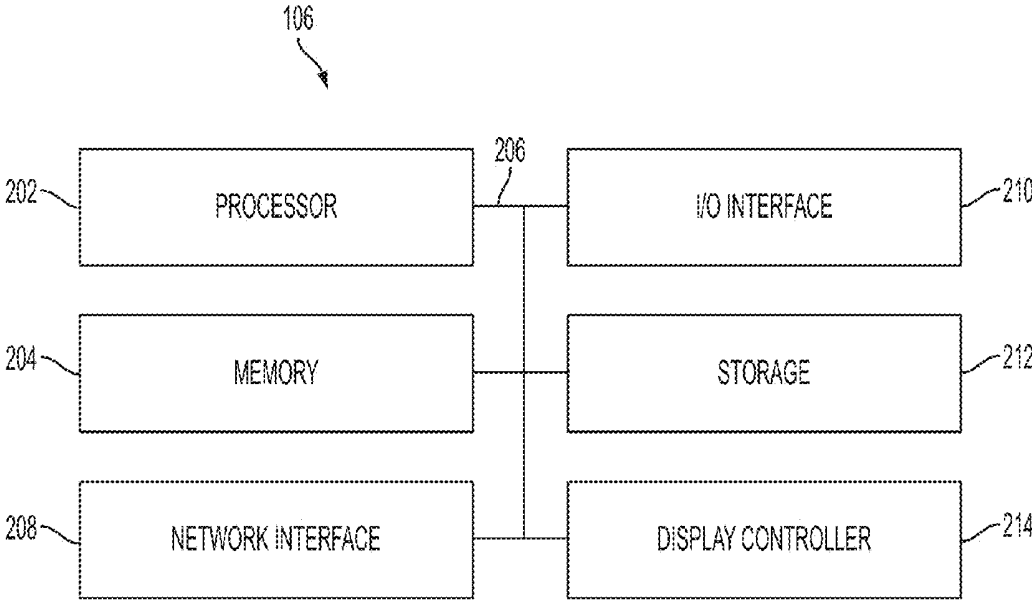

FIG. 2

00:00	CONSENT SUBJECT AND PRESENT PROTOCOL DETAILS
00:05	COLLECT INFORMATION ABOUT PATIENT (INCLUDING BODY COMP)
00:10	CONNECT PATIENT TO DEVICES AND CHECK SIGNALS
00:30	START RECORDING. WALK ON A TREADMILL
00:45	FREE ACTIVITY (SITTING AT A DESK)
01:15	DRINK 1.5 dl OF WATER
01:15	FREE ACTIVITY (SITTING AT A DESK)
01:45	DRINK 1.5 dl OF ENERGY DRINK
01:52	FREE ACTIVITY (SITTING AT A DESK)
02:15	EAT MEAL (MEASURE BODY COMPOSITION BEFORE AND AFTER)
02:45	DRINK AT LEAST 1 dl OF HOT BEVERAGE (COFFEE, TEA)
02:52	FREE ACTIVITY (SITTING AT A DESK)
03:15	EAT SNACK
03:22	FREE ACTIVITY (SITTING AT A DESK)
03:45	DISCONNECT PATIENT FROM DEVICES
03:55	PERFORM BODY COMPOSITION MEASUREMENTS
04:00	FINISH

FIG. 3A

00:00	CONSENT SUBJECT AND PRESENT PROTOCOL DETAILS
00:05	COLLECT INFORMATION ABOUT PATIENT (INCLUDING BODY COMP)
00:10	CONNECT PATIENT TO DEVICES AND CHECK SIGNALS
00:30	START RECORDING. WALK ON A TREADMILL
00:45	FREE ACTIVITY (SITTING AT A DESK)
01:15	EAT SNACK
01:22	FREE ACTIVITY (SITTING AT A DESK)
01:45	DRINK 1.5 dl OF WATER
01:52	FREE ACTIVITY (SITTING AT A DESK)
02:15	DRINK 1.5 dl OF ENERGY DRINK
02:22	FREE ACTIVITY (SITTING AT A DESK)
02:45	EAT MEAL (MEASURE BODY COMPOSITION BEFORE AND AFTER)
03:15	DRINK AT LEAST 2 dl OF WATER
03:22	FREE ACTIVITY (SITTING AT A DESK)
03:45	DISCONNECT PATIENT FROM DEVICES
03:55	PERFORM BODY COMPOSITION MEASUREMENTS
04:00	FINISH

FIG. 3B

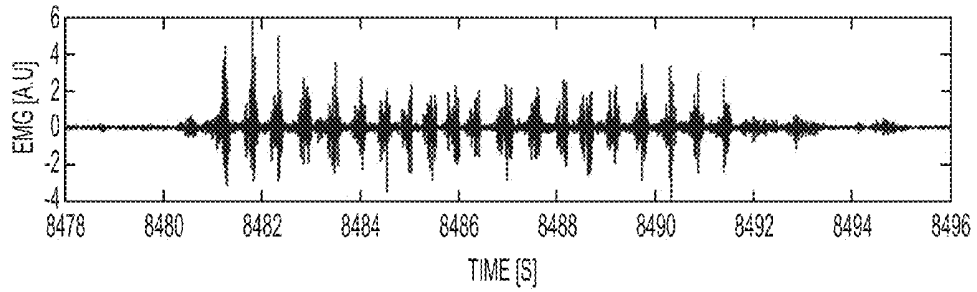

FIG. 4A

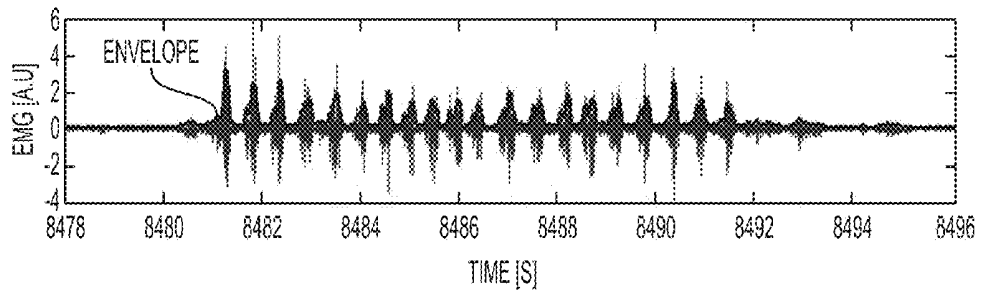

FIG. 4B

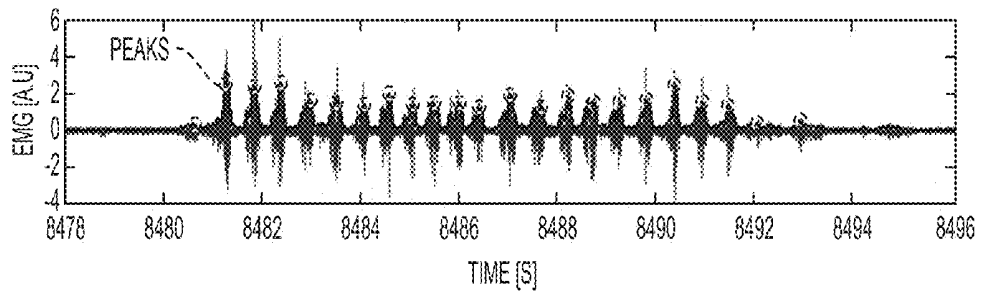

FIG. 4C

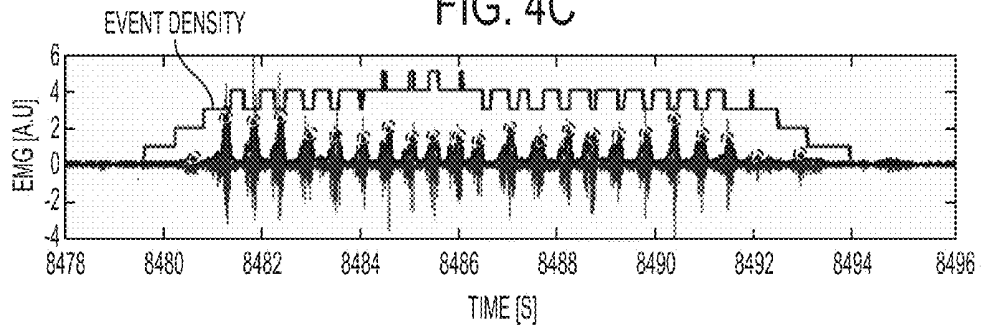

FIG. 4D

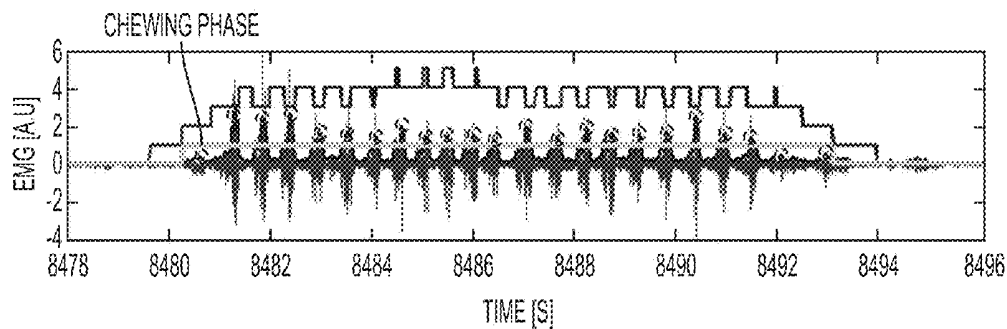

FIG. 4E

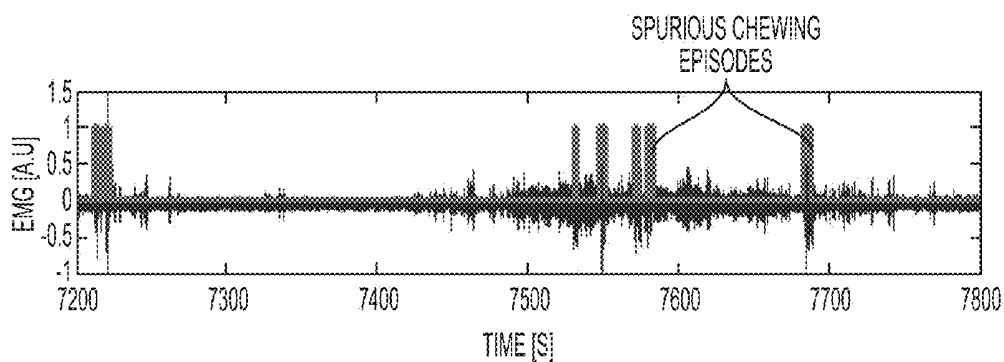

FIG. 4F

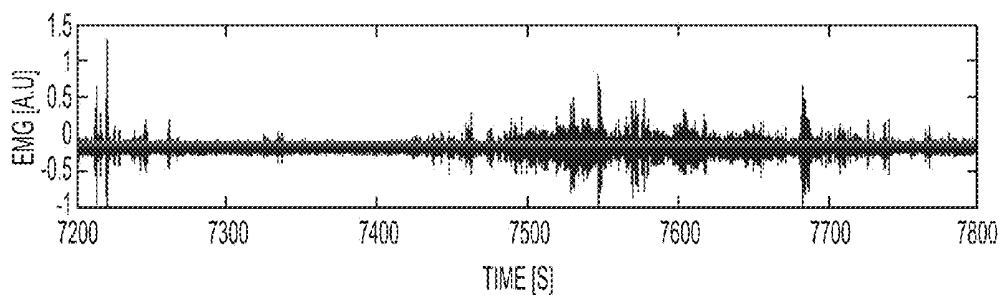

FIG. 4G

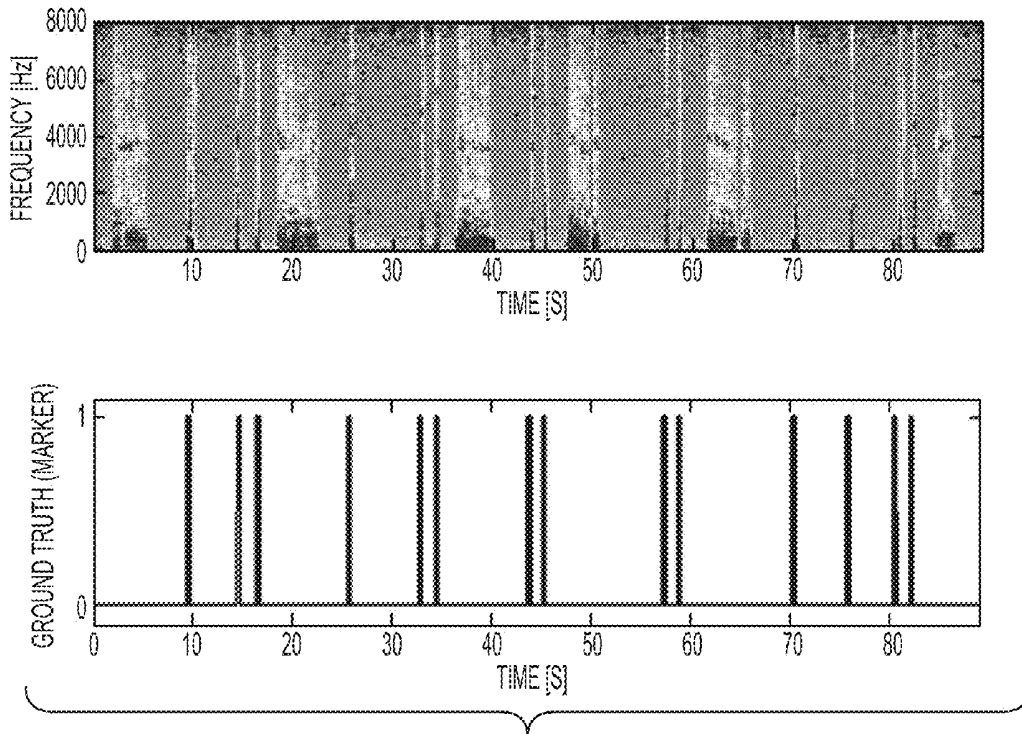

FIG. 5A

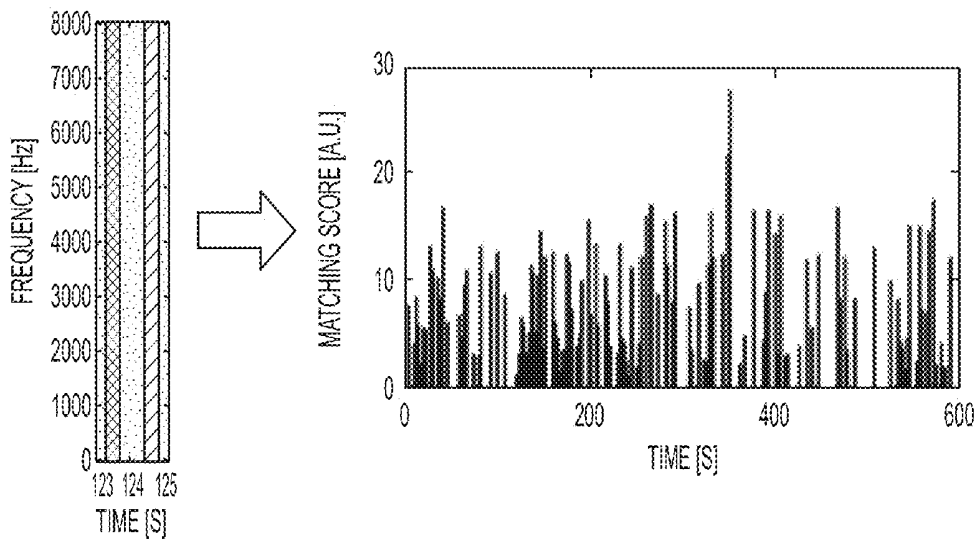

FIG. 5B

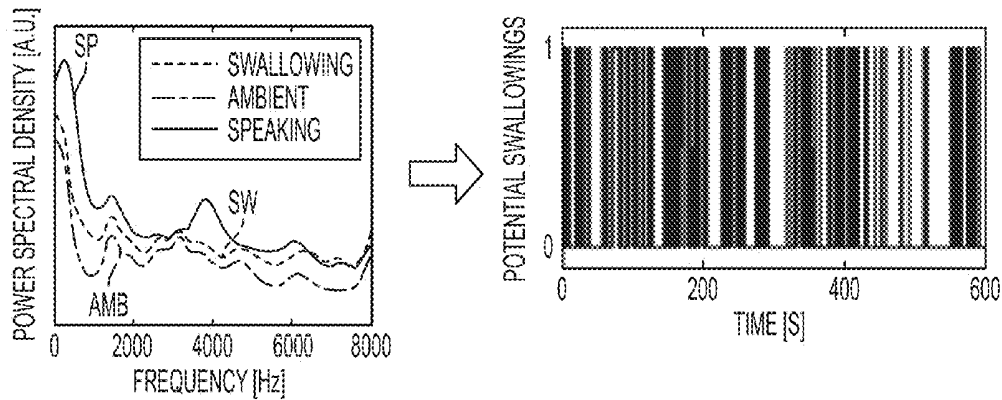

FIG. 5C

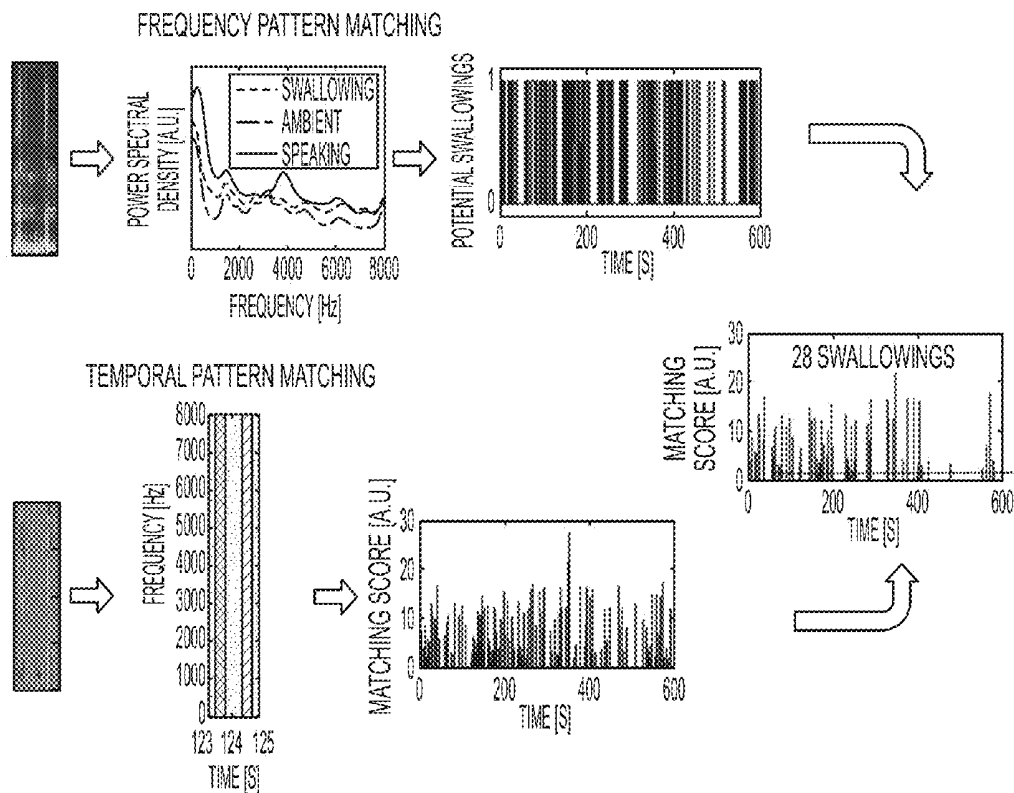

FIG. 5D

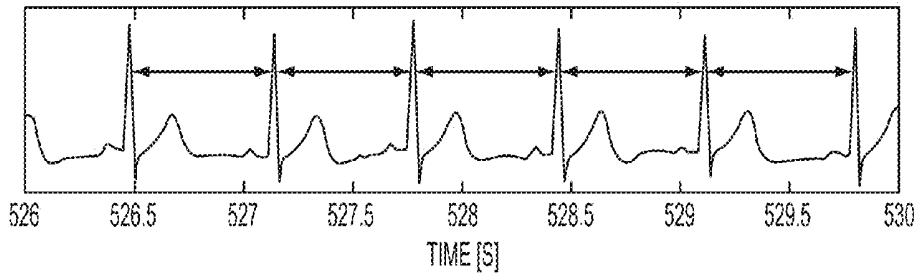

FIG. 6A

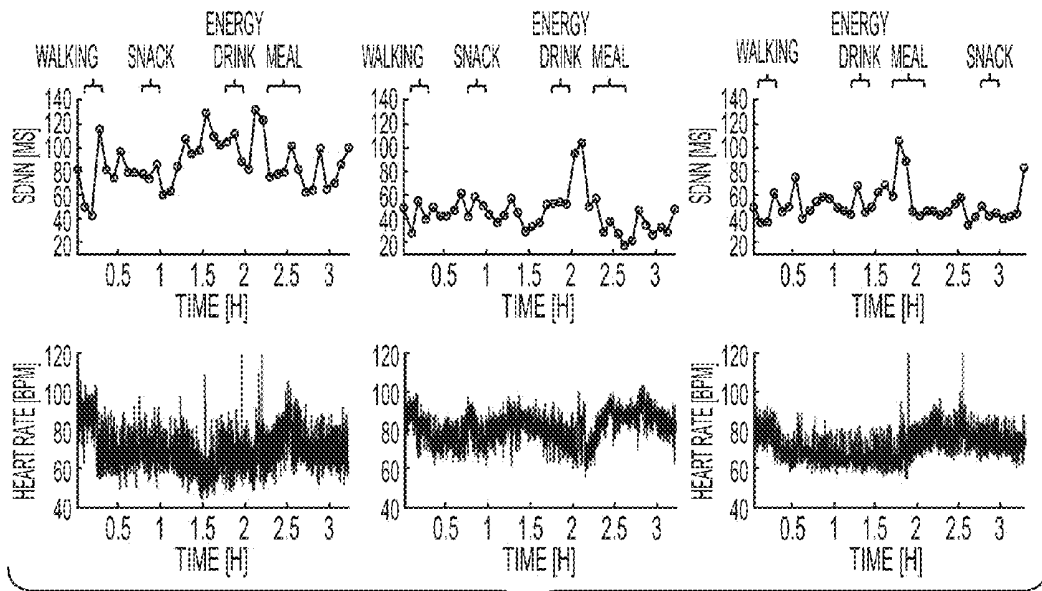

FIG. 6B

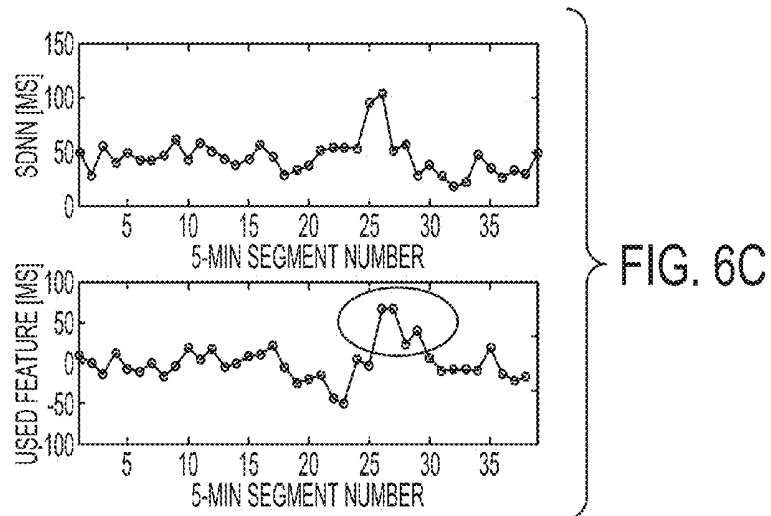

FIG. 6C

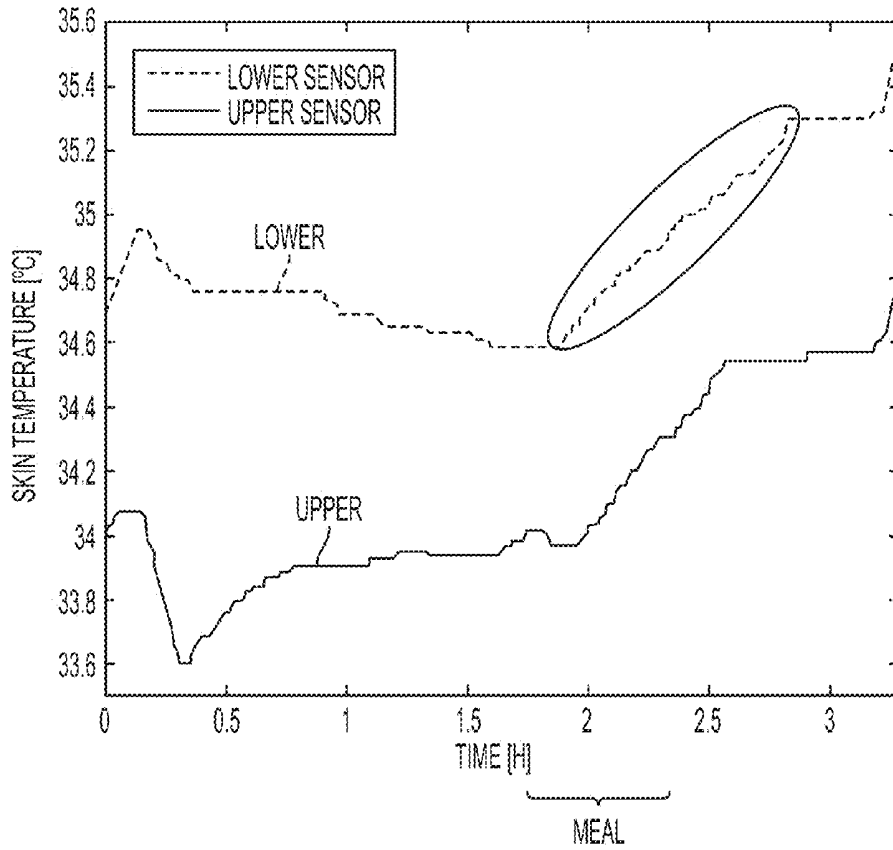

FIG. 7A

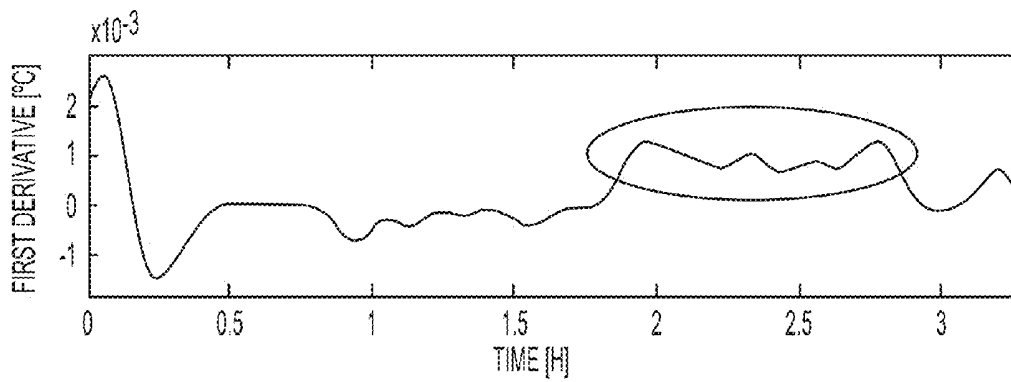

FIG. 7B

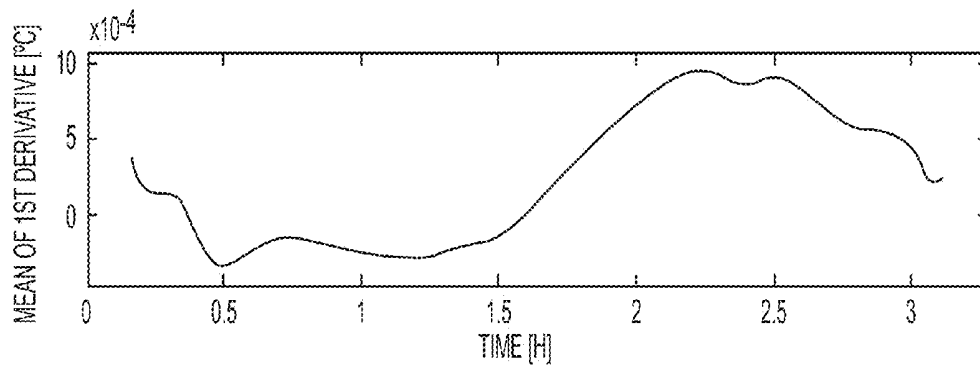

FIG. 7C

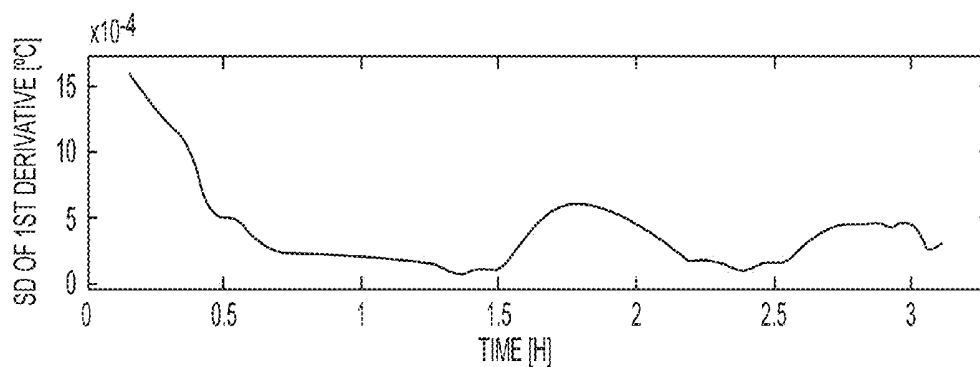

FIG. 7D

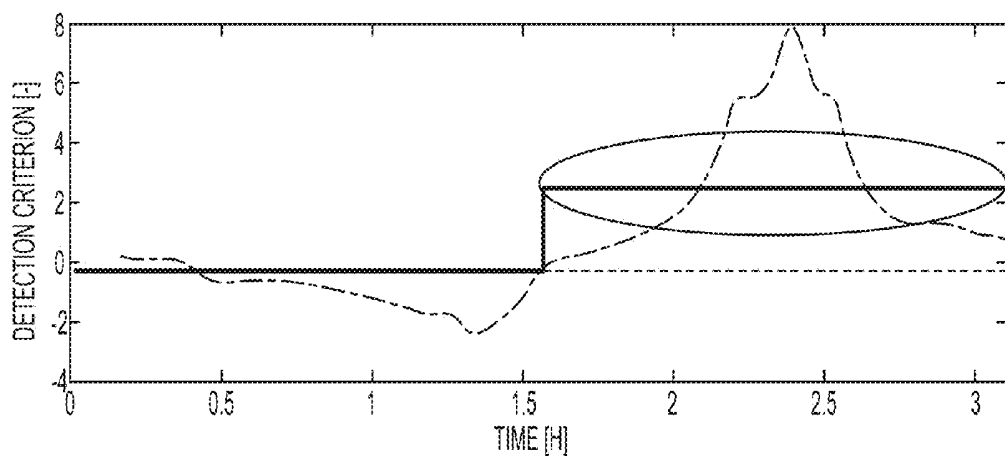

FIG. 7E

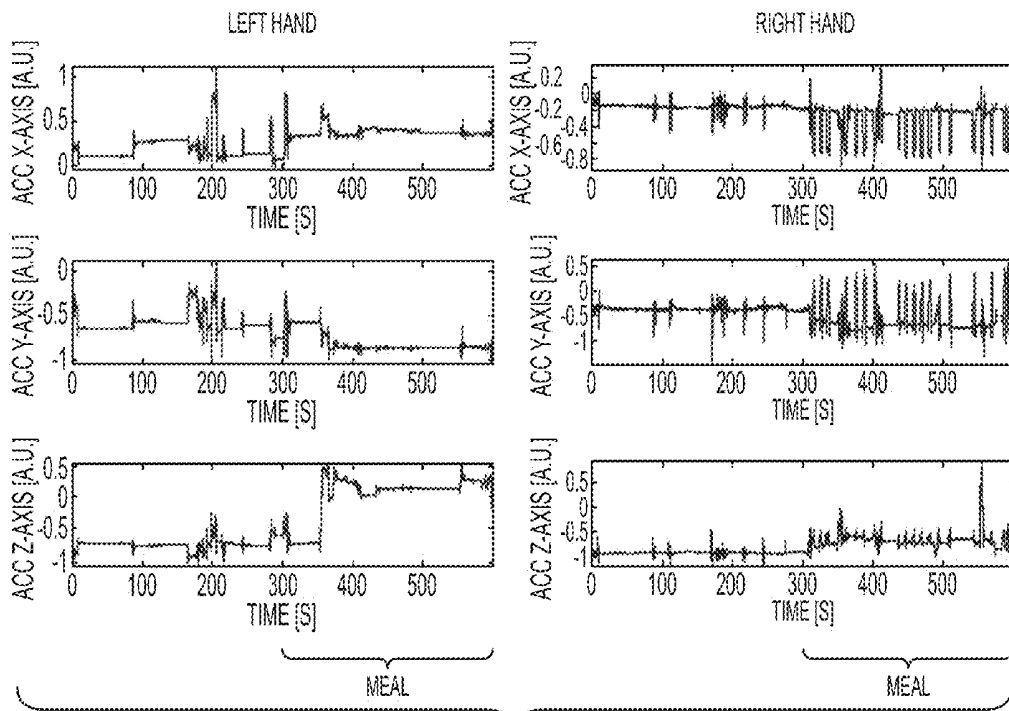

FIG. 8A

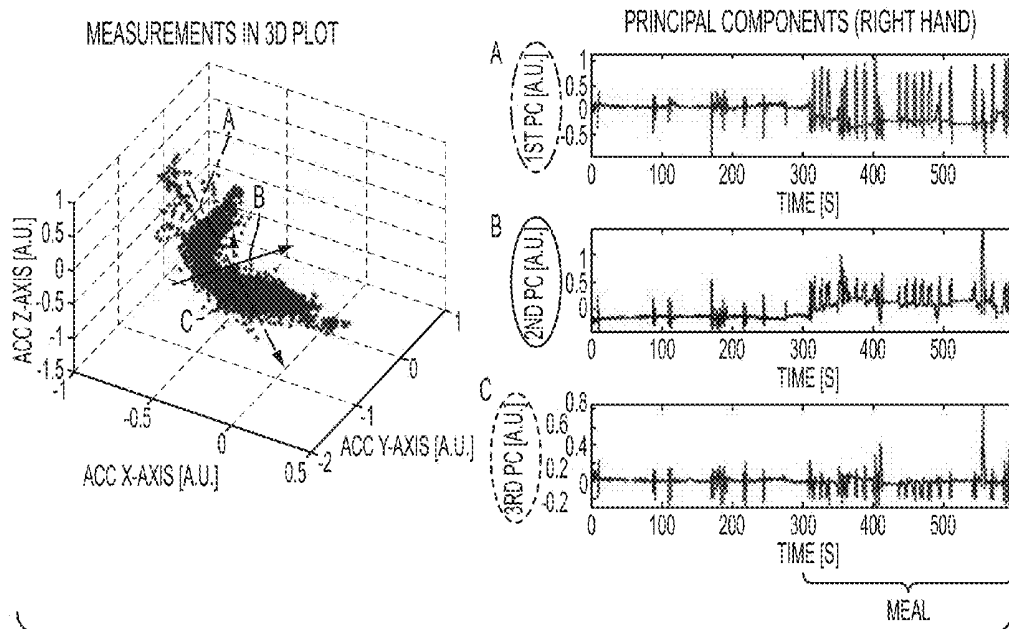

FIG. 8B

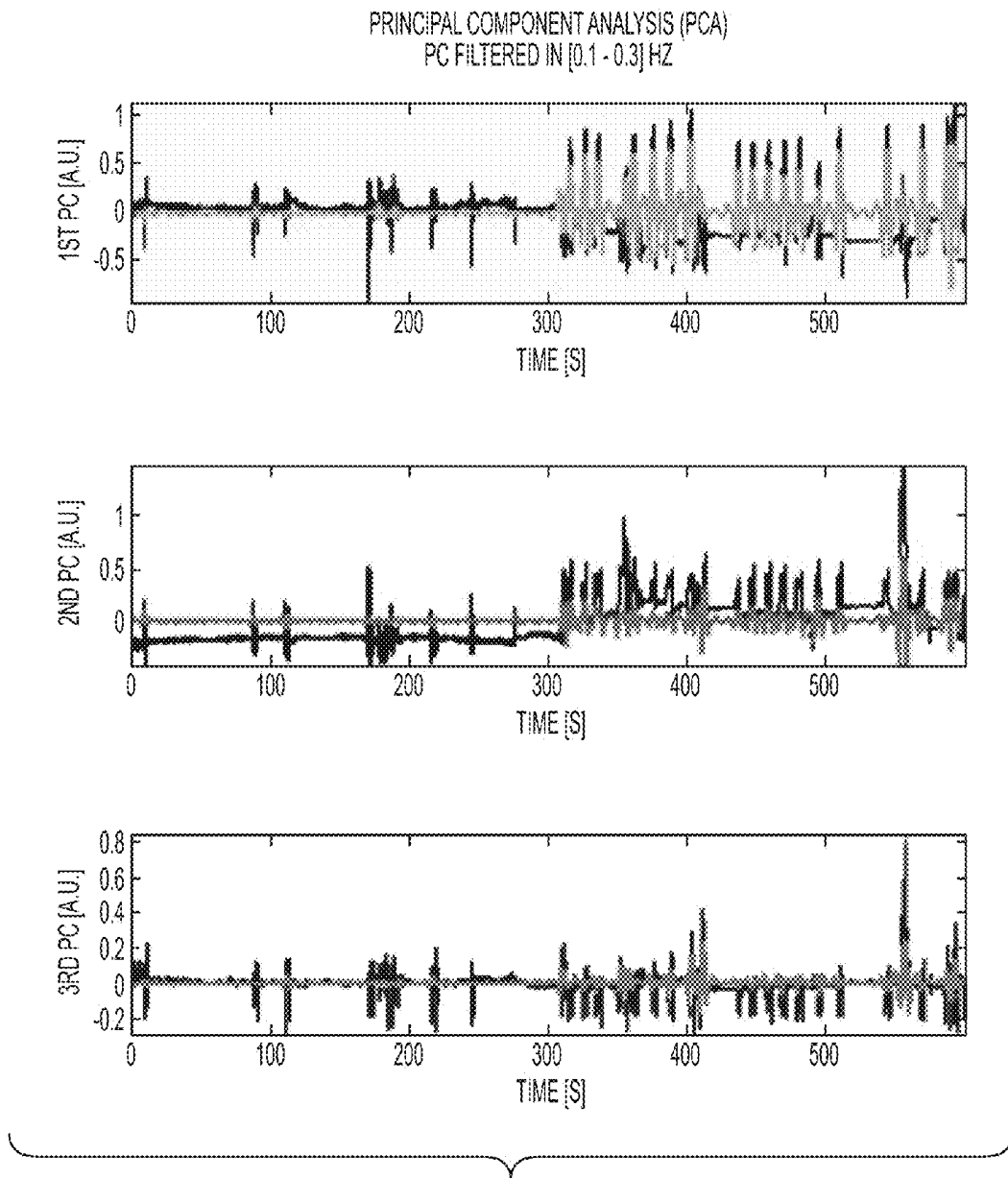

FIG. 8C

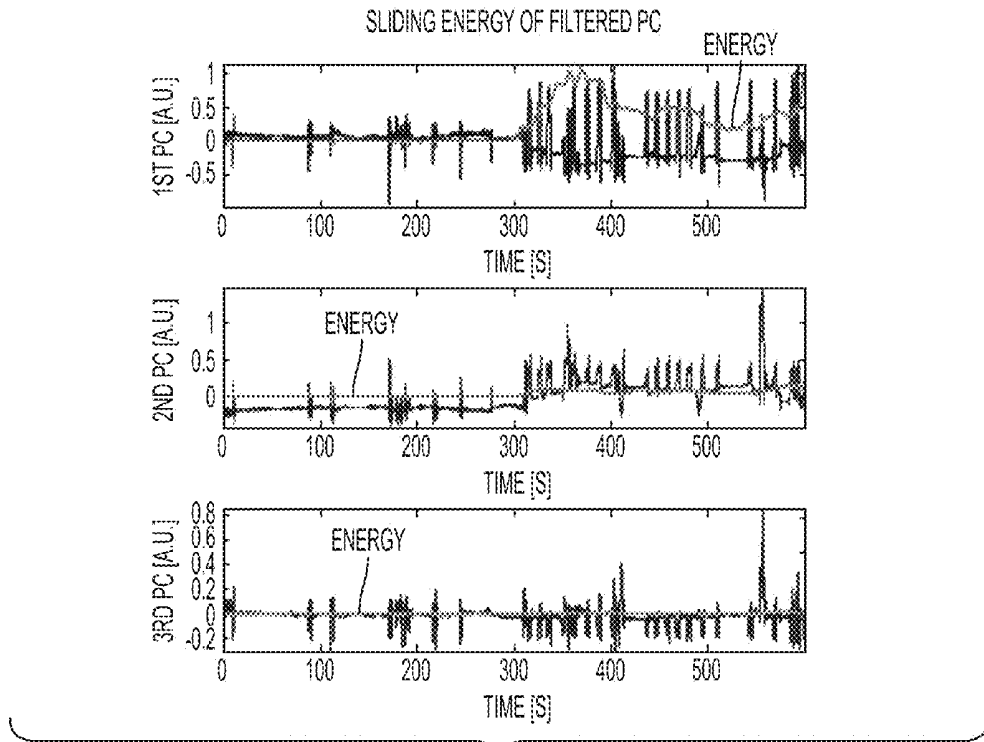

FIG. 8D

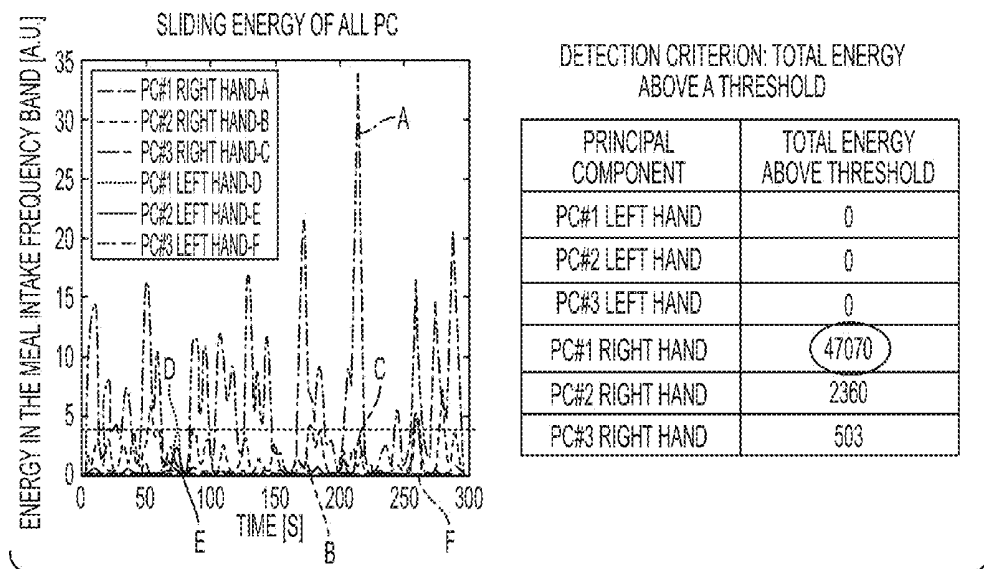

FIG. 8E

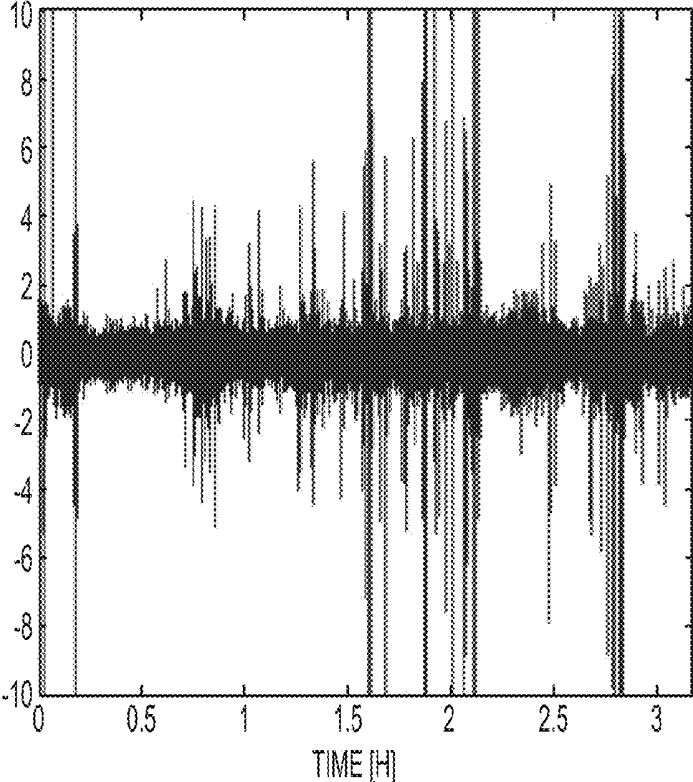

FIG. 9A

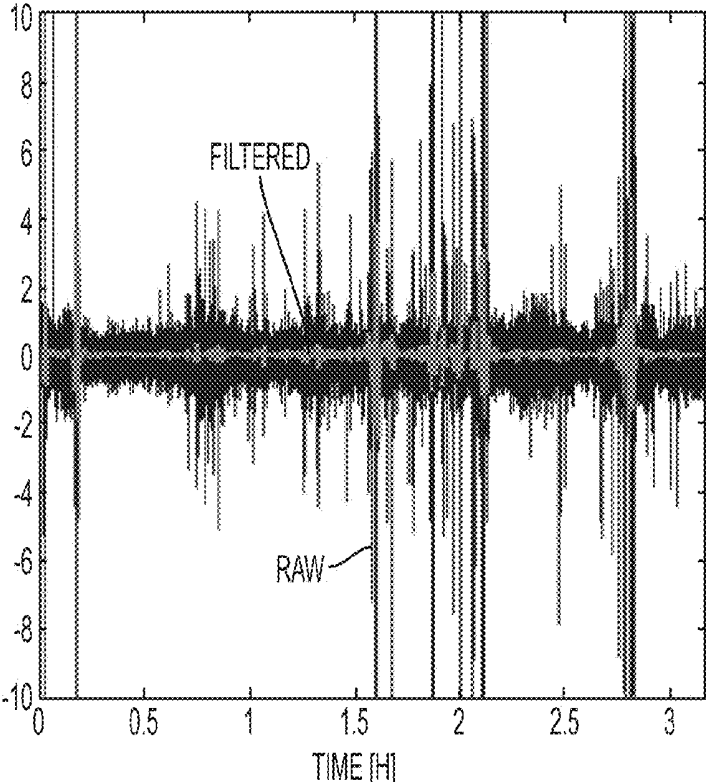

FIG. 9B

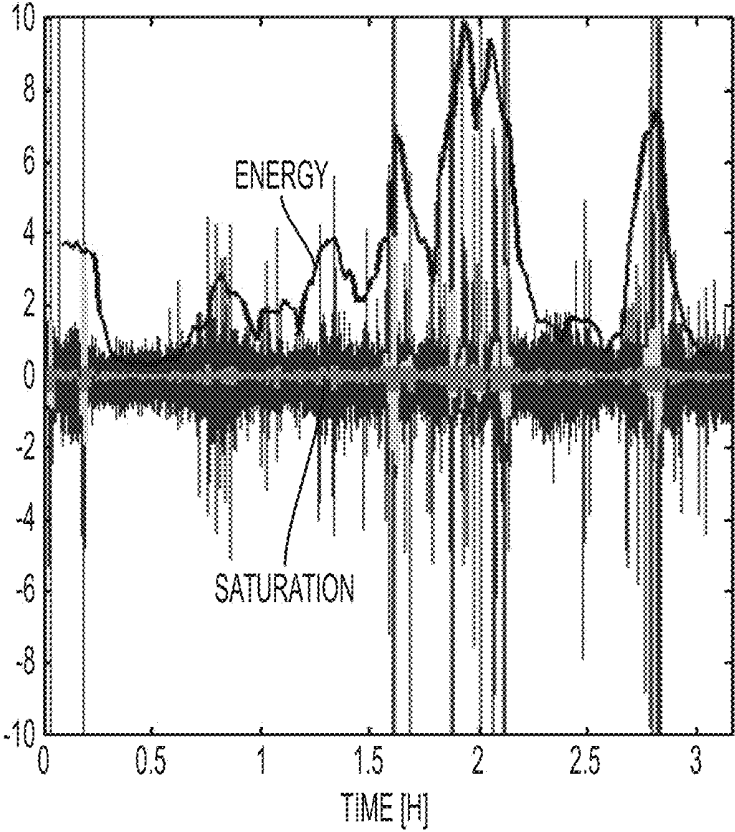

FIG. 9C

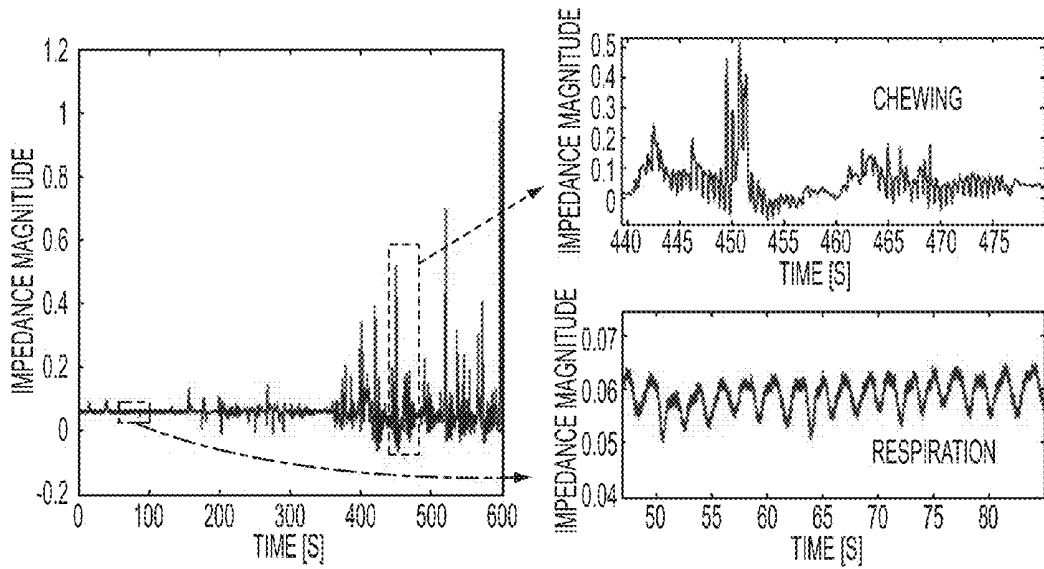

FIG. 10A

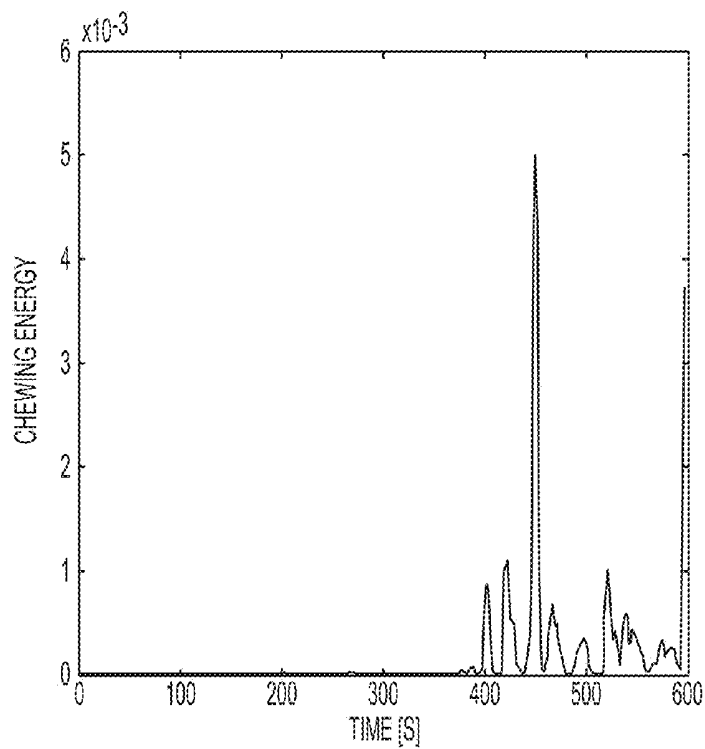

FIG. 10B

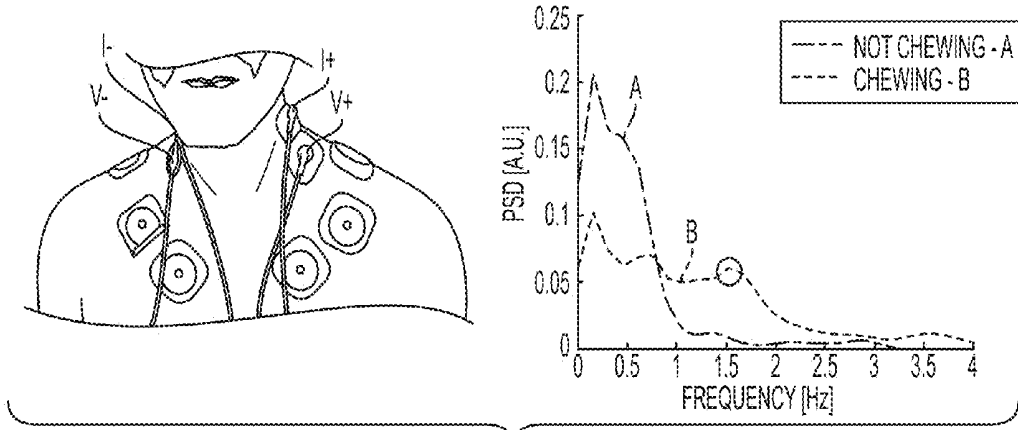

FIG. 11A

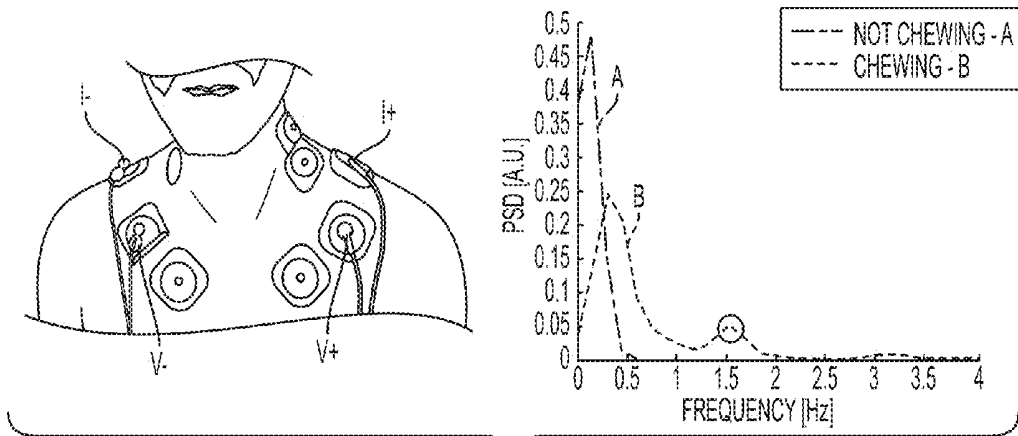

FIG. 11B

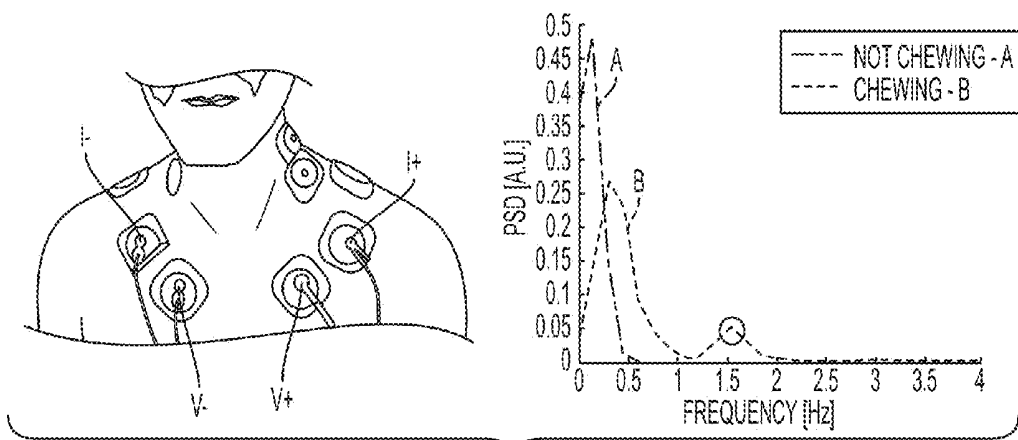

FIG. 11C

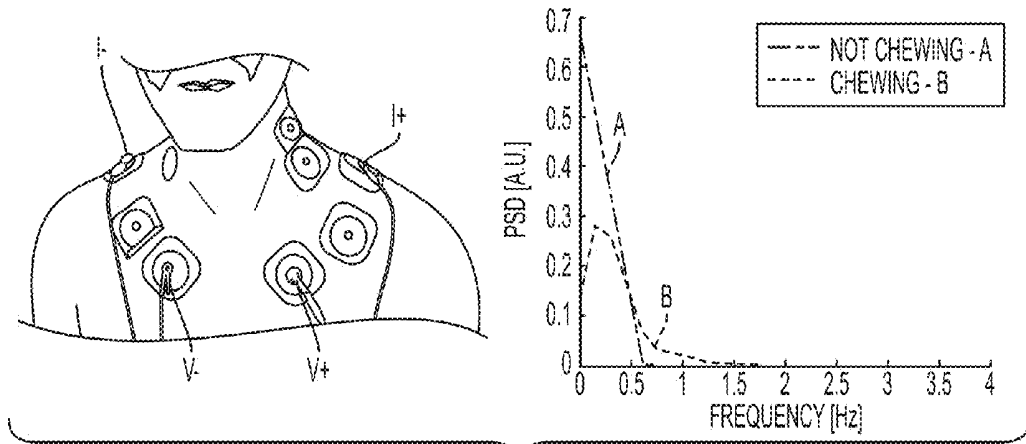

FIG. 11D

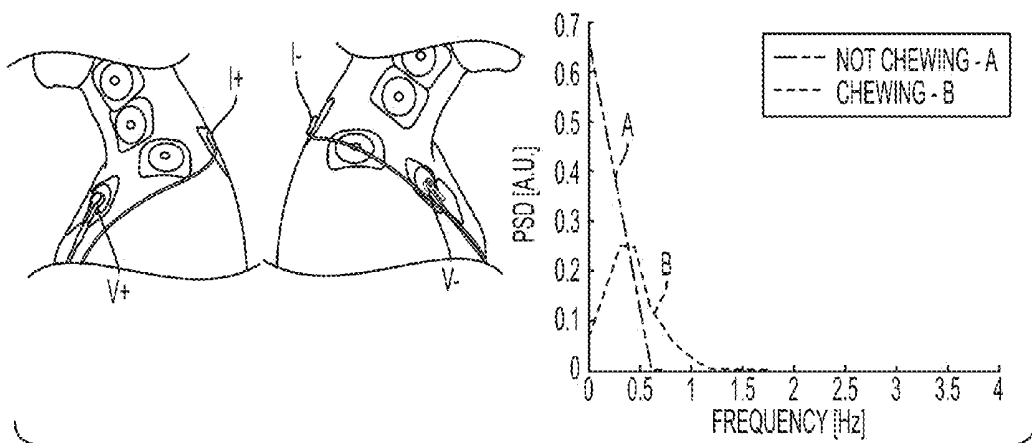

FIG. 11E

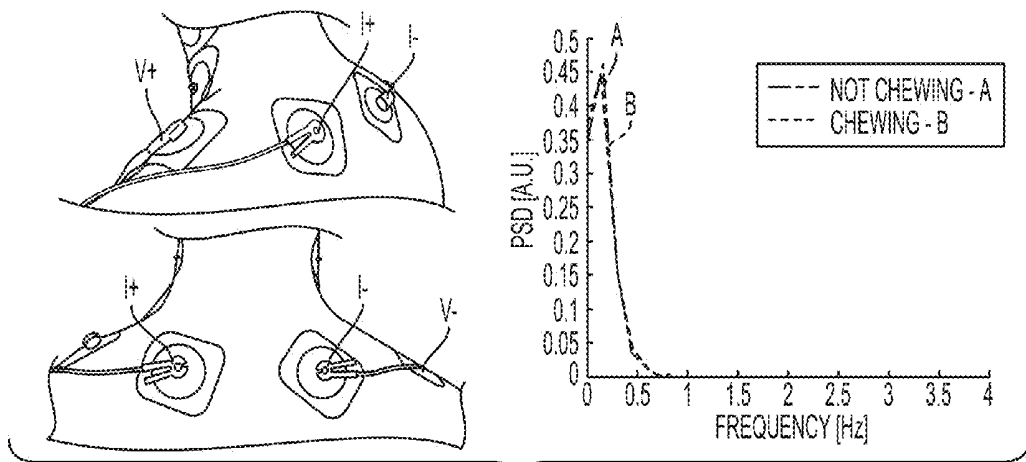

FIG. 11F

$$\text{GLOBAL SENSITIVITY} = \frac{\sum TP}{\sum TP + \sum FN}$$

$$\text{GLOBAL SPECIFICITY} = \frac{\sum TN}{\sum TN + \sum FP}$$

SENSOR	MEAL CATEGORY	GLOBAL SENSITIVITY	GLOBAL SPECIFICITY
EMG	SOLID	0.97	0.98
IMPEDANCE	SOLID	0.89	0.78
ACCELEROMETERS	SOLID + LIQUID	0.78	0.71
MICROPHONE	SOLID + LIQUID	0.69	0.73
TEMPERATURE	DIGESTION	0.80	0.29
HRV	DIGESTION	0.51	0.47
EGG	DIGESTION	0.56	0.47

FIG. 12

$$\text{GLOBAL SENSITIVITY} = \frac{\sum TP}{\sum TP + \sum FN}$$

$$\text{GLOBAL SPECIFICITY} = \frac{\sum TN}{\sum TN + \sum FP}$$

SENSORS	MEAL CATEGORY	GLOBAL SENSITIVITY	GLOBAL SPECIFICITY
EMG + ACCEL.	SOLID	0.96	0.98
	LIQUID	0.75	0.75
IMPED. + ACCEL.	SOLID	0.88	0.77
	LIQUID	0.60	0.86
EMG + MICRO	SOLID	0.96	0.98
	LIQUID	0.53	0.79
IMPED. + MICRO	SOLID	0.88	0.78
	LIQUID	0.50	0.87

FIG. 13

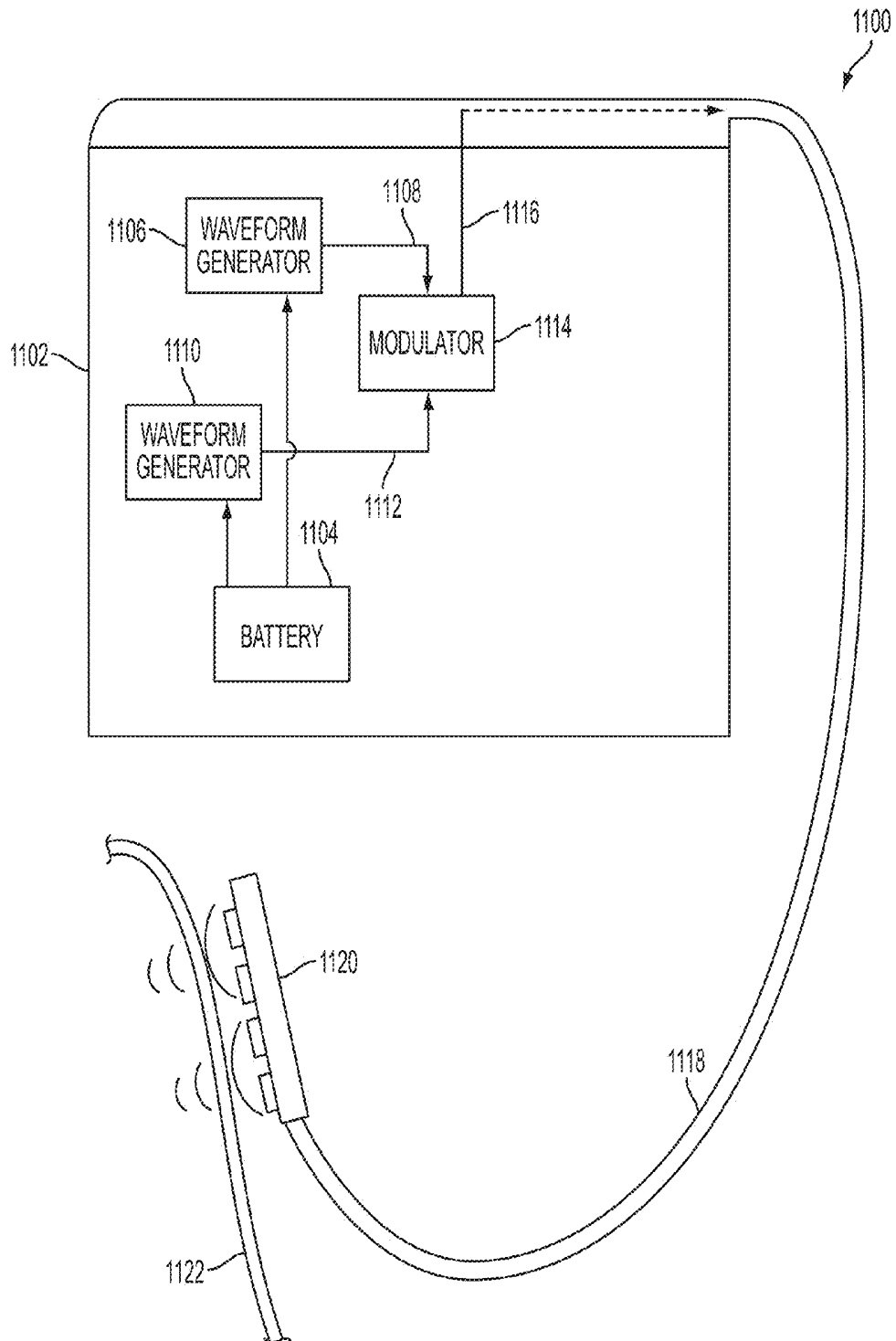

FIG. 14

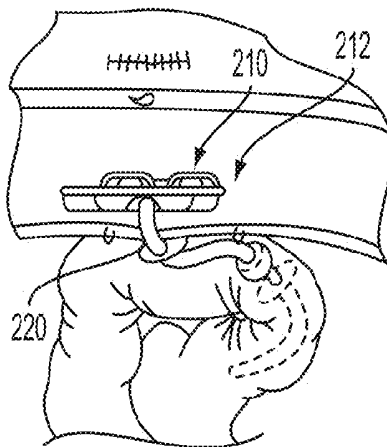

FIG. 15

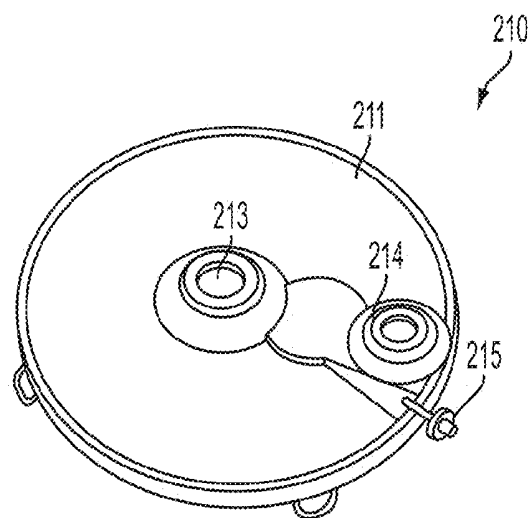

FIG. 16

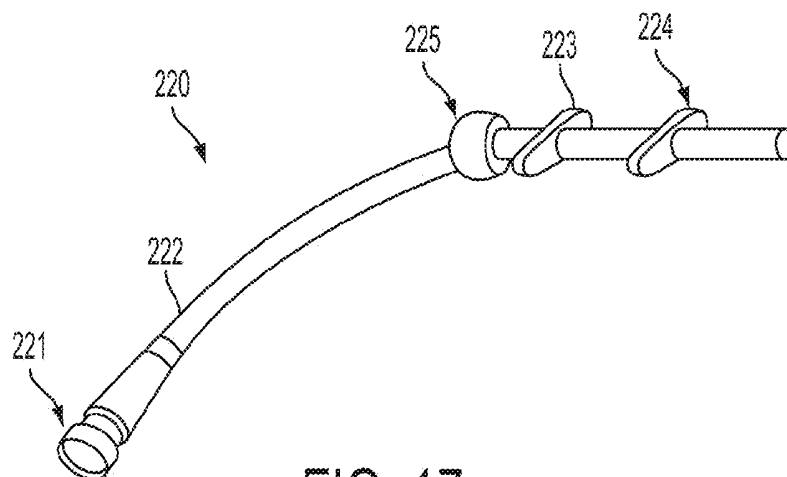

FIG. 17

MEAL DETECTION DEVICES AND METHODS

CROSS-REFERENCE TO RELATED APPLICATIONS

[0001] This application claims priority to U.S. Provisional Application No. 61/780,013 filed on Mar. 13, 2013, which is hereby incorporated by reference herein in its entirety.

FIELD

[0002] Devices and methods for detecting meal intake are disclosed herein.

BACKGROUND

[0003] A number of therapies exist or are under development which can benefit from detection of meal intake with high sensitivity and/or high specificity. For example, various obesity treatment therapies can be more effective when administered in temporal proximity to or otherwise synchronized with caloric ingestion (e.g., of solid or liquid foods or beverages). Treatment therapies for diabetes and other diseases can also benefit from precise meal detection. Without the ability to accurately detect meal intake, automated therapies are difficult if not impossible to implement.

[0004] Individuals or their caregivers can also benefit from an awareness of meal intake timing, patterns, and so forth. It is cumbersome and time consuming, however, to keep track of this information manually.

[0005] Accordingly, a need exists for accurate and reliable devices and methods for detecting meal intake.

SUMMARY

[0006] Devices and methods for detecting meal intake are disclosed herein. In some embodiments, one or more sensors can be used to detect or monitor physiological parameters of a user (e.g., heart rate, body movements, temperature, pH at one or more points along the gastrointestinal tract, impedance, gastric stretch, sound emissions, and the like). The outputs of the sensors can be received by a computer system configured to analyze the sensor data and make a determination as to whether meal intake has occurred or is presently occurring. The computer system's determination can be used to trigger, modulate, or otherwise control one or more therapeutic devices. Other types of devices can also be controlled using this determination, such as monitoring or logging devices.

[0007] In some embodiments, a meal detection system is provided that includes a plurality of sensors, each configured to sense a different physiological parameter of a user, the plurality of sensors being disposed external to the user. The system can also include a processor in communication with the plurality of sensors and configured to analyze outputs of the plurality of sensors to detect meal intake by the user, the processor being further configured to trigger a controlled device to deliver a therapy to the user in response to meal intake detected by the processor. In alternative embodiments, at least one of the sensors can be at least partially disposed within the patient.

[0008] The plurality of sensors can be of different types. The processor can be configured, for each of the plurality of sensors, to calculate an index based on the output of the sensor and to determine that meal intake occurred when the index exceeds a threshold value. The processor can be configured to

calculate the threshold value by processing a set of training data using an average harmonic mean algorithm, the training data including sensor data for at least one user and ground truth data for the at least one user.

[0009] The plurality of sensors can include an electromyograph configured to detect electrical activity of a muscle of the user and the processor can be configured to calculate an electromyograph index based on a number of peaks detected in the electromyograph output. The plurality of sensors can include a microphone configured to detect sounds emitted by the user and the processor can be configured to calculate a microphone index based on frequency matching and temporal matching of the microphone output to a predetermined pattern. The plurality of sensors can include an electrocardiograph configured to detect electrical activity of a heart of the user and the processor can be configured to calculate an electrocardiograph index based on a moving average filtered first derivative of the standard deviation of interbeat intervals in the electrocardiograph output.

[0010] The plurality of sensors can include a temperature sensor configured to detect a temperature of the user and the processor can be configured to calculate a temperature sensor index based on a ratio of low frequency components of the first derivative of the temperature sensor output to low frequency components of the standard deviation of the temperature sensor output. The plurality of sensors can include an accelerometer configured to detect motion of the user and the processor can be configured to calculate an accelerometer index based on the total energy of the accelerometer output in a frequency band of interest. The plurality of sensors can include an electrogastrograph configured to detect electrical activity of a digestive system of the user and the processor can be configured to calculate an electrogastrograph index based on the total energy of the electrogastrograph output in a frequency band of interest. The plurality of sensors can include an impedance sensor configured to detect an impedance across a portion of the user and the processor can be configured to calculate an impedance sensor index based on the median energy of the impedance sensor output in a frequency band of interest.

[0011] The plurality of sensors can include an electromyograph and an accelerometer, and the processor can be configured to calculate an electromyograph index, an electromyograph threshold value, an accelerometer index, and an accelerometer threshold value. The processor can be configured to determine that solid meal intake occurred when the electromyograph index exceeds the electromyograph threshold value, that liquid meal intake occurred when the electromyograph index does not exceed the electromyograph threshold value and the accelerometer index exceeds the accelerometer threshold value, and that no meal intake occurred when the electromyograph index does not exceed the electromyograph threshold value and the accelerometer index does not exceed the accelerometer threshold value.

[0012] The plurality of sensors can include an impedance sensor and an accelerometer, and the processor can be configured to calculate an impedance sensor index, an impedance sensor threshold value, an accelerometer index, and an accelerometer threshold value. The processor can be configured to determine that solid meal intake occurred when the impedance sensor index exceeds the impedance sensor threshold value, that liquid meal intake occurred when the impedance sensor index does not exceed the impedance sensor threshold value and the accelerometer index exceeds the accelerometer

threshold value, and that no meal intake occurred when the impedance sensor index does not exceed the impedance sensor threshold value and the accelerometer index does not exceed the accelerometer threshold value.

[0013] The plurality of sensors can include an electromyograph and a microphone, and the processor can be configured to calculate an electromyograph index, an electromyograph threshold value, a microphone index, and a microphone threshold value. The processor can be configured to determine that solid meal intake occurred when the electromyograph index exceeds the electromyograph threshold value, that liquid meal intake occurred when the electromyograph index does not exceed the electromyograph threshold value and the microphone index exceeds the microphone threshold value, and that no meal intake occurred when the electromyograph index does not exceed the electromyograph threshold value and the microphone index does not exceed the microphone threshold value.

[0014] The plurality of sensors can include an impedance sensor and a microphone, and the processor can be configured to calculate an impedance sensor index, an impedance sensor threshold value, a microphone index, and a microphone threshold value. The processor can be configured to determine that solid meal intake occurred when the impedance sensor index exceeds the impedance sensor threshold value and the microphone index exceeds the microphone threshold value, that liquid meal intake occurred when the impedance sensor index does not exceed the impedance sensor threshold value and the microphone index exceeds the microphone threshold value, and that no meal intake occurred when the impedance sensor index does not exceed the impedance sensor threshold value and the microphone index does not exceed the microphone threshold value.

[0015] The system can include a controlled device configured to perform various functions. The controlled device can be configured to at least one of: electrically stimulate tissue of the user, deliver a therapeutic agent to the user, deliver a therapeutic agent configured to provoke a release of one or more hormones from L-cells of the user to trigger ileal brake in the user, deliver insulin to the user, modulate bile acid levels in the user, modulate gastric pH levels in the user, induce an aversive response in the user, stimulate release of GLP-1 in the user, activate brown adipose tissue in the user, adjust a gastric band implanted in the user, control tonal contractions of the user's stomach, adjust a size or volume of a gastric space occupying device implanted in the user, modulate gastric emptying in the user, record a history of the user's meal intake events, and issue an alert to the user or to a caregiver of the user when the user's meal intake exceeds a predetermined threshold or deviates from a predetermined pattern.

[0016] In some embodiments, a medical method is provided that includes sensing a plurality of physiological parameters of a user using a plurality of sensors disposed externally to the user and, using a processor in communication with the plurality of sensors, analyzing outputs of the plurality of sensors to detect meal intake by the user. The method can include automatically triggering a controlled device to deliver a therapy to the user in response to meal intake detected by the processor. The delivery of the therapy can be configured to commence with the initiation of the meal, the end of the meal, or at a predetermined time after the start or end of the meal.

[0017] The method can include, for each of the plurality of sensors, using the processor to calculate an index based on the output of the sensor and using the processor to determine that meal intake occurred when the index exceeds a threshold value. The method can include using the processor to calculate the threshold value by processing a set of training data using an average harmonic mean algorithm, the training data including sensor data for at least one user and ground truth data for the at least one user.

[0018] Said sensing and said analyzing can include at least one of: detecting electrical activity of a muscle of the user using an electromyograph and calculating an electromyograph index based on a number of peaks detected in the electromyograph output, detecting sounds emitted by the user using a microphone and calculating a microphone index based on frequency matching and temporal matching of the microphone output to a predetermined pattern, detecting electrical activity of a heart of the user using an electrocardiograph and calculating an electrocardiograph index based on a moving average filtered first derivative of the standard deviation of interbeat intervals in the electrocardiograph output, detecting a temperature of the user and calculating a temperature sensor index based on a ratio of low frequency components of the first derivative of the temperature sensor output to low frequency components of the standard deviation of the temperature sensor output, detecting motion of the user using an accelerometer and calculating an accelerometer index based on the total energy of the accelerometer output in a frequency band of interest, detecting electrical activity of a digestive system of the user using an electrogastrograph and calculating an electrogastrograph index based on the total energy of the electrogastrograph output in a frequency band of interest, and detecting an impedance across a portion of the user using an impedance sensor and calculating an impedance sensor index based on the median energy of the impedance sensor output in a frequency band of interest.

[0019] Triggering the controlled device can include causing the controlled device to at least one of: electrically stimulate tissue of the user, deliver a therapeutic agent to the user, deliver a therapeutic agent configured to provoke a release of one or more hormones from L-cells of the user to trigger ileal brake in the user, deliver insulin to the user, modulate bile acid levels in the user, modulate gastric pH levels in the user, induce an aversive response in the user, stimulate release of GLP-1 in the user, activate brown adipose tissue in the user, adjust a gastric band implanted in the user, control tonal contractions of the user's stomach, adjust a size or volume of a gastric space occupying device implanted in the user, modulate gastric emptying in the user, record a history of the user's meal intake events, and issue an alert to the user or to a caregiver of the user when the user's meal intake exceeds a predetermined threshold or deviates from a predetermined pattern.

[0020] Sensing the plurality of physiological parameters can include detecting an impedance across a portion of the user using an impedance sensor having a first current electrode, a second current electrode, a first voltage electrode, and a second voltage electrode. The method can include positioning the first current electrode on the user's left trapezius muscle, positioning the second current electrode on the user's right trapezius muscle, positioning the first voltage electrode on the user's chest below the user's left clavicle and about half way between the user's neck and the user's left shoulder, and positioning the second voltage electrode on the user's chest

below the user's right clavicle and about half way between the user's neck and the user's right shoulder. Alternatively, or in addition, the method can include positioning the first current electrode on the user's chest below the user's left clavicle and about half way between the user's neck and the user's left shoulder, positioning the second current electrode on the user's chest below the user's right clavicle and about half way between the user's neck and the user's right shoulder, positioning the first voltage electrode beneath the first current electrode and inward towards the user's sternum, and positioning the second voltage electrode beneath second current electrode and inward towards the user's sternum.

[0021] The present invention further provides devices and methods as claimed.

BRIEF DESCRIPTION OF THE DRAWINGS

[0022] The invention will be more fully understood from the following detailed description taken in conjunction with the accompanying drawings, in which:

[0023] FIG. 1 is a schematic diagram of a controlled device and a meal detection system having a plurality of sensors coupled to a user;

[0024] FIG. 2 is a schematic diagram of a computer system of the meal detection system of FIG. 1;

[0025] FIG. 3A is an exemplary protocol for use in obtaining training data for calibrating the meal detection system of FIG. 1;

[0026] FIG. 3B is another exemplary protocol for use in obtaining training data for calibrating the meal detection system of FIG. 1;

[0027] FIGS. 4A-4G illustrate an exemplary method of calculating an index for an electromyograph;

[0028] FIGS. 5A-5D illustrate an exemplary method of calculating an index for a microphone;

[0029] FIGS. 6A-6C illustrate an exemplary method of calculating an index for an electrocardiograph;

[0030] FIGS. 7A-7E illustrate an exemplary method of calculating an index for a temperature sensor;

[0031] FIGS. 8A-8E illustrate an exemplary method of calculating an index for an accelerometer;

[0032] FIGS. 9A-9C illustrate an exemplary method of calculating an index for an electrogastrograph;

[0033] FIGS. 10A-10B illustrate an exemplary method of calculating an index for an impedance sensor;

[0034] FIGS. 11A-11F illustrate exemplary placements of impedance sensor electrodes on a patient;

[0035] FIG. 12 is a table of sensitivity and specificity for various sensors and meal categories;

[0036] FIG. 13 is a table of sensitivity and specificity for various sensor combinations and meal categories;

[0037] FIG. 14 is a schematic diagram of a controlled device for administering electrical stimulation to a user;

[0038] FIG. 15 is a side view of a controlled device for administering a therapeutic agent to a user, the device being shown implanted in the user;

[0039] FIG. 16 is a perspective view of a reservoir portion of the controlled device of FIG. 15; and

[0040] FIG. 17 is a perspective view of a catheter portion of the controlled device of FIG. 15.

DETAILED DESCRIPTION

[0041] Certain exemplary embodiments will now be described to provide an overall understanding of the prin-

ciples of the structure, function, manufacture, and use of the devices and methods disclosed herein. One or more examples of these embodiments are illustrated in the accompanying drawings. Those of ordinary skill in the art will understand that the devices and methods specifically described herein and illustrated in the accompanying drawings are non-limiting exemplary embodiments and that the scope of the present invention is defined solely by the claims. The features illustrated or described in connection with one exemplary embodiment may be combined with the features of other embodiments. Such modifications and variations are intended to be included within the scope of the present invention.

INTRODUCTION

[0042] Devices and methods for detecting meal intake are disclosed herein. In some embodiments, one or more sensors can be used to detect or monitor physiological parameters of a user (e.g., heart rate, body movements, temperature, pH at one or more points along the gastrointestinal tract, impedance, gastric stretch, sound emissions, and the like). The outputs of the sensors can be received by a computer system configured to analyze the sensor data and make a determination as to whether meal intake has occurred or is presently occurring. The computer system's determination can be used to trigger, modulate, or otherwise control one or more therapeutic devices. Other types of devices can also be controlled using this determination, such as monitoring or logging devices.

[0043] Such devices and methods can be used to trigger automated or manual therapies for treating a user. In some embodiments, therapy can be administered to the user for a limited period of time such that the user stops receiving the therapy prior to a second onset of meal intake, e.g., the user beginning a second eating session, which can trigger a second delivery of the therapy to the user for a limited period of time. In other words, the user can intermittently receive therapy throughout a period of hours, days, weeks, months, etc., with each delivery of the therapy coinciding with meal intake. By providing therapy in conjunction with eating and/or drinking, the therapy can be most effective in treating a user condition and/or encouraging weight loss. Accurate meal detection provided by such devices and methods can be an important baseline prerequisite for automated or semi-automated therapies, including obesity and insulin treatment therapies, as well as others. Therapies for metabolic disorders can also be more effective if coordinated with meal intake.

[0044] References herein to "meal ingestion" or "meal intake" can include ingestion of solid foods, liquid foods, beverages, snacks, and so forth, whether caloric or otherwise.

[0045] System Generally

[0046] FIG. 1 illustrates an exemplary embodiment of a meal detection system 100 for detecting meal intake by a user 102. The system 100 generally includes one or more sensors 104 configured to sense physiological parameters of the user 102 and a computer system 106 configured to process and interpret the outputs of the one or more sensors to make a determination as to whether meal intake has occurred or is presently occurring. Each sensor 104 can monitor different physiological parameters of the user. A controlled device 108 can be coupled to the meal detection system 100 such that the meal detection system is configured to trigger, modulate, or otherwise control the controlled device 108 based on determinations made by the computer system 106.

[0047] The sensors **104**, the computer system **106**, and the controlled device **108** can all be implanted within the user **102**, can all be positioned external to the user, or some can be implanted while others are positioned externally. For example, some components can be positioned subcutaneously while others are positioned transcutaneously. Components of the system which are implanted can be powered using an implanted power source or can be powered remotely, for example as disclosed in U.S. Pat. No. 7,599,743 filed Jun. 24, 2004 entitled "Low Frequency Transcutaneous Energy Transfer To Implanted Medical Device." The computer system **106** can be configured for implantation in the user, for example by including a hermetically-sealed biocompatible coating. The computer system **106** can also be configured to be worn or carried by the user, for example by integrating the computer system **106** with an article of clothing or other accessory. The computer system **106** can be, or can be included in, a portable computer, a desktop computer, a handheld electronic device such as a mobile phone, etc., as will be appreciated by a person skilled in the art. It will be appreciated that any combination of the sensors **104**, the computer system **106**, and the controlled device **108** can be integrated into a single physical device, housing, package, or system.

[0048] The computer system **106** can be directly coupled to the sensors **106** and the controlled device **108**, e.g., using electrically-conductive wires or leads, or can be wirelessly coupled thereto using various protocols known in the art. Sensor data can be transmitted to the computer system **106** in real time. The computer system **106** can also be configured to send instructions to the sensors **104**, for example to reset or calibrate the sensors, or to instruct the sensors to take a measurement.

[0049] Computer System

[0050] FIG. 2 illustrates an exemplary architecture of the computer system **106**. Although an exemplary computer system **106** is depicted and described herein, it will be appreciated that this is for sake of generality and convenience. In other embodiments, the computer system may differ in architecture and operation from that shown and described here. For example, a system on chip (SOC) architecture can be used to decrease the size of the computer system and increase its portability and/or implantability.

[0051] The illustrated computer system **106** includes a processor **202** which controls the operation of the computer system **106**, for example by executing an operating system (OS), device drivers, application programs, and so forth. The processor **202** can include any type of microprocessor or central processing unit (CPU), including programmable general-purpose or special-purpose microprocessors and/or any of a variety of proprietary or commercially-available single or multi-processor systems. The computer system **106** also includes a memory **204**, which provides temporary or permanent storage for code to be executed by the processor **202** (e.g., programs being configured to cause the computer system **106** to perform one or more steps) or for data that is processed by the processor **202**. The memory **204** can include read-only memory (ROM), flash memory, one or more varieties of random access memory (RAM), and/or a combination of memory technologies. The various elements of the computer system **106** are coupled to a bus system **206**. The illustrated bus system **206** is an abstraction that represents any one or more separate physical busses, communication lines/interfaces, and/or multi-drop or point-to-point connections, connected by appropriate bridges, adapters, and/or controllers.

[0052] The computer system **106** also includes a network interface **208**, an input/output (I/O) interface **210**, a storage device **212**, and a display controller **214**. The network interface **208** enables the computer system **106** to communicate with remote devices (e.g., other computer systems) over a network. The I/O interface **210** facilitates communication between one or more input devices (e.g., the sensors **104**), one or more output devices, and the various other components of the computer system **106**. The storage device **212** can include any conventional medium for storing data and programs in a non-volatile and/or non-transient manner. The storage device **212** can thus hold data and/or instructions in a persistent state (i.e., the value is retained despite interruption of power to the computer system **106**). The storage device **212** can include one or more hard disk drives, flash drives, USB drives, optical drives, various media disks or cards, and/or any combination thereof and can be directly connected to the other components of the computer system **106** or remotely connected thereto, such as over a network. The display controller **214** includes a video processor and a video memory, and generates images to be displayed on one or more displays in accordance with instructions received from the processor **202**.

[0053] The various functions performed by the meal detection system **100** can be logically described as being performed by one or more modules. It will be appreciated that such modules can be implemented in hardware, software, or a combination thereof. It will further be appreciated that, when implemented in software, modules can be part of a single program or one or more separate programs, and can be implemented in a variety of contexts (e.g., as part of an operating system, a device driver, a standalone application, and/or combinations thereof). In addition, software embodying one or more modules can be stored as an executable program on one or more non-transitory computer-readable storage mediums. Functions disclosed herein as being performed by a particular module can also be performed by any other module or combination of modules, and the meal detection system **100** can include fewer or more modules than what is shown and described herein.

[0054] It will be appreciated that sensor data can be communicated to the computer system **106** instantaneously or near-instantaneously. The computer system **106** can thus analyze relatively recent data and relatively quickly begin analysis thereof, as will be appreciated by a person skilled in the art. In this way, the computer system **106** can make a relatively quick determination as to whether the user has begun ingesting a meal. This in turn can be used to trigger the controlled device **108** in a relatively quick manner. In other words, if the computer system **106** determines from the gathered data that the user started ingesting a meal, delivery of a therapy to the user can be automatically initiated relatively soon after the onset of meal intake.

[0055] The computer system **106** can perform various signal processing functions with respect to the sensor data to make the data more suitable for meal intake determinations or for calculating a measurement index for assessing whether meal intake has likely occurred, e.g., as detailed below with respect to each sensor type. The computer system **106** can include a meal intake determination module configured to make a determination as to whether meal intake has occurred or is presently occurring. The meal intake determination module can also be configured to determine or estimate the size of the meal, for example based on the signal count or pattern of one or more sensor outputs, e.g., an electromyography.

graph, an impedance sensor, and/or an accelerometer. Any of a variety of algorithms can be used to make the meal intake determination based on sensor data received by the computer system **106**.

[0056] In some embodiments, the determination algorithm can include comparing an index value calculated for a particular sensor over a particular window of time to a predetermined threshold value. Index values for a plurality of sensors can also be considered together in making the meal intake determination. Further details on determination algorithms are provided below.

[0057] Sensors

[0058] Generally, the sensors **104** can be configured to gather data from the user **102** regarding one or more physiological parameters of the user, and each sensor typically gathers data for a different physiological parameter. The sensors **102** can be in communication with the computer system **106** such that the sensors communicate sensed data to the computer system **106** for processing. A number of exemplary sensors are described below.

[0059] An externally-located sensor can allow for meal detection and therapy triggering without requiring surgery to implant the sensor, thereby reducing, if not eliminating, adverse side effects and potential complications from surgery. If a controlled device configured to be triggered based on data gathered by an externally-located sensor is also transcutaneously positioned, e.g., in the form of a transdermal patch configured to electrically stimulate the user, then the user can be effectively treated without requiring any surgery, thereby eliminating adverse side effects and potential complications from surgery. However, it will be appreciated that the sensors **104** can also be implanted in the user as part of a surgical procedure (e.g., a surgical procedure to treat severe obesity).

[0060] A plurality of sensors can be used simultaneously to inform the meal intake determination, providing redundancy in case of sensor and/or communication failure, and increasing accuracy in determining that meal intake has occurred or is occurring. For example, sensor combinations can be used in which one sensor is very effective at detecting one type of activity (e.g., eating solid food) and another sensor is very effective at detecting a different type of activity (e.g., drinking or exercise) such that the combination of sensors provides a synergistic improvement in meal detection accuracy.

[0061] In some embodiments, a measurement index can be calculated for each sensor or for each sensor type and can be compared to a threshold value to inform a meal intake determination. While a number of exemplary index types and threshold values are disclosed below, it will be appreciated that other index types or threshold values can be used depending on the particular application and its sensitivity and specificity requirements and other factors.

[0062] Threshold values can be determined empirically by monitoring one or more subjects as they perform various activity protocols. Exemplary protocols are illustrated in FIGS. 3A and 3B. Sensor data can be captured during the protocols along with an individual ground truth for each subject (e.g., a log of when the subject is actually chewing, swallowing, or digesting). This training data can be divided into a plurality of time segments (e.g., segments of 5 minutes each). The number of true positives (TP), true negatives (TN), false positives (FP), and false negatives (FN) can be calculated, along with the equivalent sensitivity (TP/(TP+FN)) and specificity (TN/(TN+FP)). A sensitivity value SE(n, T) and

specificity value SP(n, T) can be determined for each possible threshold value T and for each subject n in the training set. An average harmonic mean of the sensitivity and specificity can be calculated to determine an ideal threshold value for the sensor that optimizes specificity and sensitivity. Average harmonic mean of sensitivity SE(n, T) and specificity SP(n, T) can be calculated according to:

$$H(T) = \frac{1}{N} \sum_{n=1}^N \frac{2 \cdot SE(n, T) \cdot SP(n, T)}{SE(n, T) + SP(n, T)},$$

where n represents the subject index, T is the determination threshold value, and N is the number of subjects in the training set. The maximum value of T in the function H(t) can be used as the determination threshold for the sensor. Threshold values for each sensor type can be determined empirically and stored in the memory **204** of the computer system **106** during manufacturing for subsequent use with all users of the system **100**.

[0063] Alternatively, or in addition, user-specific thresholds can be used. For example, a training set can consist solely of the individual end-user of the meal detection system **100**. The meal detection system **100** can thus be operable in a training mode in which sensor data is recorded and the user provides ground truth information to the computer system **106** (e.g., by manually signaling to the meal detection system **100** when meal intake is occurring, and optionally the type and volume of the meal intake). This information can be used by the computer system **106** as described above to define thresholds for each sensor that are tailored to the individual user. Later, when the meal detection system **100** is no longer operating in the training mode, these thresholds can be used to automatically detect meal intake without requiring additional user input. Reference is made herein to various sensor outputs or indexes “exceeding” a threshold. It will be appreciated that “exceeding” a threshold can, in some instances, be understood to mean crossing a threshold. In other words, a value that is numerically less than a threshold value can be considered to “exceed” the threshold when the threshold is defined such that values which are numerically less than the threshold are considered a trigger. For example, if a threshold is defined as “trigger when less than 7,” then a value of 3 can be said to “exceed” the threshold.

[0064] Electromyographs (EMG)

[0065] The one or more sensors **104** can include an electromyograph (“EMG”) configured to sense or detect electrical potential of one or more of the user’s muscles. The electromyograph can generate an output signal that represents the muscle’s electrical potential as a function of time. The electromyograph can include surface leads or electrodes configured for attachment to the user’s skin and/or intramuscular leads or electrodes configured to be placed within the observed muscles, e.g., in the form of needles or wires. In some embodiments, the electromyograph can have a sampling rate of about 312.5 Hz. Exemplary electromyographs include the Biopac MP150 Data Acquisition System and the Biopac 100C Biopotential Amplifier available from Biopac Systems, Inc.

[0066] The electromyograph electrodes can be coupled to, or configured to measure, various muscles or muscle groups of the user. For example, as shown in FIG. 1, the electromyograph electrodes **110** can be coupled to the user’s jaw muscles

(e.g., the masseter, the temporalis, the sphenomandibularis, the medial pterygoid, the lateral pterygoid, the hyoid, and/or the sternohyomastoid). Alternatively, or in addition, the electromyograph electrodes can be coupled to other muscles, such as the user's neck muscles or abdominal muscles. Each time the monitored muscles are fired (e.g., the jaw muscles when chewing food), a peak can be generated in the electromyograph output. Information representing the number of peaks that occur in a certain period of time or the amplitude/intensity of the peaks can be used for meal detection purposes.

[0067] The electromyograph output can be received by the computer system **106** and can be conditioned and otherwise processed to detect meal intake by the user. FIG. 4A illustrates an exemplary raw output signal generated by the electromyograph and communicated to the computer system **106**. The computer system **106** can analyze the sensor output in segments that correspond to discrete windows of time. For example, the computer system **106** can record the sensor output for a predetermined time period (e.g., 10 seconds, 30 seconds, 1 minute, 5 minutes, 10 minutes, etc.) and, at the conclusion of the predetermined time period or thereafter, analyze the sensor output corresponding to that time period.

[0068] The computer system **106** can perform envelope extraction to produce an estimated superior envelope of the raw electromyograph signal for the time period under consideration, as shown in FIG. 4B. The computer system **106** can then perform peak detection (FIG. 4C) and event density (FIG. 4D) processing. As shown in FIG. 4E, the computer system **106** can extract a chewing phase from the processed data. Chewing episodes associated with meal intake are typically characterized by multiple, rhythmic chewing events. Accordingly, spurious chewing episodes, shown in FIG. 4F, can be excluded from the data using an index that is the ratio of the number of detected peaks to the variance of the inter-peak intervals.

[0069] Time periods in which the electromyograph output produces an index value below the threshold amount can be excluded as not involving meal intake. Thus, as shown in FIG. 4G, the spurious chewing events of FIG. 4F can be ignored. Time periods in which the electromyograph output produces an index values greater than or equal to the threshold can be interpreted as meal intake by the user or, as discussed below, can be used in conjunction with other data to make such an interpretation. In some embodiments, the threshold index value can be about 43. Accordingly, peak-detection based processing can be used to detect chewing events from the electromyograph output.

[0070] Microphones

[0071] The one or more sensors can include a microphone configured to sense or detect sounds generated or emitted by the user. A variety of microphone types can be used, including condenser microphones, dynamic microphones, ribbon microphones, carbon microphones, piezoelectric microphones, fiber optic microphones, laser microphones, liquid microphones, and MEMS microphones. The microphone can include an acoustic-to-electric transducer that converts sounds generated by the user into an electrical output signal.

[0072] The microphone transducer can be configured for attachment to the user's skin or clothing, or can be implanted in the user. In some embodiments, the microphone can have a sampling rate of about 44,100 Hz. Exemplary microphones include the NT3 Throat Microphone System available from IASUS Concepts Ltd.

[0073] The microphone can be coupled to, aimed at, or disposed in proximity to various portions of the user. For example, as shown in FIG. 1, a first microphone **112** can be coupled to the user's throat and a second microphone **114** can be coupled to the user's abdomen in the vicinity of the user's stomach. The first microphone can detect sounds emitted by the user's throat when the user is swallowing. The second microphone can detect sounds emitted by the user's gastrointestinal system as food or beverages are digested. When such sounds are detected, a signature pattern can be generated in the microphone output. Information representing the number of patterns that occur in a certain period of time or the amplitude/intensity of the patterns can be used for meal detection.

[0074] The microphone output can be received by the computer system **106** and can be conditioned and otherwise processed to detect meal intake by the user. The computer system **106** can analyze the microphone output in segments that correspond to discrete windows of time. For example, the computer system **106** can record the microphone output for a predetermined time period (e.g., 10 seconds, 30 seconds, 1 minute, 5 minutes, 10 minutes, etc.) and, at the conclusion of the predetermined time period or thereafter, analyze the microphone output corresponding to that time period.

[0075] FIG. 5A is time-frequency spectrogram that exemplifies the output of a throat microphone during a period that includes plural swallowing events, shown with a corresponding ground truth plot. As shown, a discernable pattern coincides with each swallowing event. In the illustrated embodiment, the pattern is characterized by short duration episodes of a large frequency band. The computer system **106** can perform various signal processing routines to condition the raw microphone output. For example, notch filters can be used to eliminate noise in a particular frequency band and its harmonics. A non-linear spatial filter can be used to make the frequency pattern more pronounced. A spectrogram applied to the filtered output can be normalized to diminish the effect of residual noise, for example by normalizing the power over the entire spectrogram.

[0076] In some embodiments, swallowing events can be extracted using a combination of frequency and temporal pattern recognition. The processed spectrogram described above can be used to compute temporal gradient values. The correlation between the obtained temporal gradient values and a template characterized by consecutive positive, null, and negative gradient values can be computed over the entire recording. FIG. 5B illustrates an exemplary template and the resulting matching score for an exemplary sensor output. Speech episodes can be rejected by computing local power spectral densities (PSD) and testing for correlation with PSD templates of swallowing (SW), speaking (SP), and ambient (AMB) episodes, respectively, as shown in FIG. 5C. Template and binarized scores can be obtained by computing the template/processed spectrogram correlation for each sampling time. Maximum correlation values associated with the swallowing pattern can be scored as "1" while index values of "0" can be assigned otherwise. The frequency and temporal scores can then be multiplied to obtain a final index value. FIG. 5D schematically illustrates the complete processing scheme.

[0077] In other words, a first score can be obtained by performing frequency pattern matching and a second score can be obtained by performing temporal pattern matching. The product of the spectral score and the temporal score can

be used as a detection threshold index. Microphone recordings with index values below the threshold amount can be excluded as not involving meal intake. Microphone recordings with index values greater than or equal to the threshold can be interpreted as meal intake by the user or, as discussed below, can be used in conjunction with other data to make such an interpretation. In some embodiments, the threshold index value for a throat or larynx microphone can be about 5.5. It will be appreciated that similar techniques can be used to obtain threshold values for microphones directed at other portions of the user, such as the user's stomach. Accordingly, a combination of frequency and temporal pattern matching can be used to detect swallowing events from the output of a throat microphone.

[0078] Electrocardiographs (ECG)

[0079] The one or more sensors can include an electrocardiograph ("ECG") configured to sense or detect electrical activity of the user's heart. The electrocardiograph can generate an output signal that represents the heart's electrical activity as a function of time. The electrocardiograph can include surface leads or electrodes configured for attachment to the user's skin and/or implantable leads or electrodes configured to be placed within the user's body. In some embodiments, the electrocardiograph can have a sampling rate of about 321.25 Hz. Exemplary electrocardiographs include the SEN3—Sense V2 System available from CSEM.

[0080] The electrocardiograph electrodes can be coupled to the user at a variety of locations. For example, as shown in FIG. 1, the electrocardiograph electrodes **116** can be coupled to the user's thorax or trunk at a plurality of locations. The electrocardiograph output can be used to determine the user's heart rate and to detect changes in the user's heart rate (e.g., heart rate variability (HRV)). The computer system **106** can analyze the electrocardiograph output and determine whether the HRV indicates an onset of the user ingesting food or drink.

[0081] Changes in heart rate can occur after ingestion, as discussed for example in Friesen et al., "Autonomic Nervous System Response To A Solid Meal And Water Loading In Healthy Children: Its Relation To Gastric Myoelectrical Activity," *Neurogastroenterol Motil.* 19(5): 376-382 (2007); Friesen et al., "The Effect Of A Meal And Water Loading On Heart Rate Variability In Children With Functional Dyspepsia," *Dig Dis Sci* 55: 2283-2387 (2010); Yin et al., "Inhibitory Effects Of Stress On Postprandial Gastric Myoelectrical Activity And Vagal Tone In Healthy Subjects," *Neurogastroenterol Motil* 16(6): 737-744 (December 2004); Watanabe et al., "Effects of water ingestion on gastric electrical activity and heart rate variability in healthy subjects," *J Auton Neuro Syst* 58(1-2): 44-50 (1996); and Lipsitz et al., "Hemodynamic And Autonomic Nervous System Responses To Mixed Meal Ingestion In Healthy Young And Old Subjects And Dysautonomic Patients With Postprandial Hypotension," *Circulation*, 87: 391-400 (1993).

[0082] HRV analysis can be performed in a variety of ways, such as using time-domain and/or frequency-domain methods, as will be appreciated by a person skilled in the art. Generally, the time-domain methods can include calculations directly from raw R-R interval time series data, e.g., raw data of times from the peak of one R to the next R peak in a QRS complex of an echocardiogram, such as by using the standard deviation of all normal R-R intervals (SDNN), the standard deviation of the successive differences (SDSD) between R-R intervals, etc. Generally, the frequency-domain methods can include calculating a power spectral density (PSD) of R-R

interval time series data. Calculating the PSD can be divided into nonparametric, e.g., fast Fourier transform (FFT) based calculations and parametric, e.g., autoregressive model, calculations. The PSD can be analyzed by calculating power and peak frequencies for different frequency bands, such as a very low frequency (VLF) band, e.g., in a range of about 0 to 0.04 Hz, a low frequency (LF) band, e.g., in a range of about 0.04 to 0.15 Hz, and a high frequency (HF) band, e.g., in a range of about 0.15 to 0.4 Hz. The LF band can represent sympathetic activity, and the HF band can represent parasympathetic activity.

[0083] In healthy, normal users after meal intake, power in the LF band can increase, while power in the HF band can decrease. Analysis of LF and HF bands can therefore result in a determination that meal intake has occurred when power in the LF band increases a certain threshold amount while power in the HF band decreases a threshold amount. Accordingly, in an exemplary embodiment, the computer system **106** can analyze a power spectral density in LF and HF bands to determine onset of meal intake. Such parameters are described in further detail in Lipsitz et al., "Hemodynamic And Autonomic Nervous System Responses To Mixed Meal Ingestion In Healthy Young And Old Subjects And Dysautonomic Patients With Postprandial Hypotension," *Circulation*, 87: 391-400 (1993) and in Lu et al., *Digestive Diseases and Sciences*, Vol 44 (4) 857-861.

[0084] The electrocardiograph output can be received by the computer system **106** and can be conditioned and otherwise processed to detect meal intake by the user. FIG. 6A illustrates an exemplary raw output signal generated by the electrocardiograph and communicated to the computer system **106**. The computer system **106** can analyze the sensor output in segments that correspond to discrete windows of time. For example, the computer system **106** can record the sensor output for a predetermined time period (e.g., 10 seconds, 30 seconds, 1 minute, 5 minutes, 10 minutes, etc.) and, at the conclusion of the predetermined time period or thereafter, analyze the sensor output corresponding to that time period.

[0085] The electrocardiograph output can be processed to identify R waves which represent heart beats. Interbeat intervals NN can then be extracted by the computer system **106** and various time-domain features can be extracted for a given time period (e.g., 5 minutes). Exemplary time-domain HRV features include the standard deviation of all NN intervals (SDNN), the square root of the mean of the squares of differences between adjacent NN intervals (RMSSD), and the standard deviation of differences between adjacent NN intervals (SDSD), each of which can be specified in milliseconds. A spectral analysis can then be performed using an autoregressive model to obtain various frequency-domain features. Exemplary frequency-domain features include the power in a very low frequency range (less than or equal to 0.04 Hz) (VLF), the power in a low frequency range (0.04 to 0.15 Hz) (LF), and the power in a high frequency range (0.15-0.4 Hz) (HF). The ratio of LF to HF can also be obtained (LF/HF). Any of these features can be used to determine whether the meal intake has occurred or is presently occurring.

[0086] As shown in FIG. 6B, the SDNN parameter can decrease at the beginning of meal intake. Accordingly, SDNN can be used by the computer system **106** to calculate an index for use in a decision algorithm. For example, the negative of the moving average filtered value of the first derivative of the SDNN can be used. A decrease in SDNN produces a negative

slope and thus a negative derivative. These values can be computed for each time segment, moving average filtered, and negated to be used by a decision algorithm in which a feature of interest should increase during meal intake episodes. FIG. 6C illustrates the obtained index, which is expected to be positive after meal intake episodes.

[0087] Time periods with index values below a threshold amount can be excluded as not involving meal intake. Time periods with index values greater than or equal to the threshold can be interpreted as meal intake by the user or, as discussed below, can be used in conjunction with other data to make such an interpretation. In some embodiments, the threshold amount can be about -3.8 . Accordingly, a negative slope based index can be used by the computer system 106 to determine from the electrocardiograph output whether digestion is occurring.

[0088] Temperature Sensors

[0089] The one or more sensors can include a temperature sensor configured to measure the user's body temperature. In particular, the user's skin temperature can be measured at one or more locations using temperature sensors. The temperature sensors can generate an output signal that represents the user's temperature as a function of time. In some embodiments, the temperature sensors can have a sampling rate of about 0.2 Hz. Exemplary temperature sensors include the SEN Orange-Sensi Medi System available from CSEM.

[0090] The temperature sensor(s) can be coupled to the user at a variety of locations. For example, as shown in FIG. 1, temperature sensors 118 can be coupled to the user's thorax or trunk at a plurality of locations. The temperature sensors can also be coupled to the user's ear lobes. The temperature sensor output can be used to determine the user's temperature and changes in the user's temperature. When a plurality of temperature sensors are used, a temperature gradient of the user can be measured. Thus, in some embodiments, a plurality of temperature sensors can be coupled to the user's torso to detect the temperature gradient across the user's torso.

[0091] The temperature sensor output can be received by the computer system 106 and can be conditioned and otherwise processed to detect ingestion by the user. For example, increases in user temperature can be associated with meal intake. FIG. 7A illustrates exemplary raw output signals generated by upper torso and lower torso temperature sensors and communicated to the computer system 106. The illustrated time period shows the output before, during, and after a meal is consumed by the user. As shown, the user's skin temperature generally increases during and after meal ingestion. The computer system 106 can analyze the sensor output in segments that correspond to discrete windows of time. For example, the computer system 106 can record the sensor output for a predetermined time period (e.g., 10 seconds, 30 seconds, 1 minute, 5 minutes, 10 minutes, etc.) and, at the conclusion of the predetermined time period or thereafter, analyze the sensor output corresponding to that time period.

[0092] In some embodiments, a positive slope based index can be used to evaluate the temperature sensor output. The computer system 106 can compute the first derivative of the lower torso skin temperature, as shown in FIG. 7B. A low-pass finite-impulse-response (FIR) filter can then be applied to the first derivative using a simple moving average window which can be, e.g., 30 minutes in length to extract the low frequency components of the first derivative signal, as shown in FIG. 7C. The standard deviation of the lower torso skin temperature can then be computed and the same FIR filter can

be applied to the resulting signal, as shown in FIG. 7D. The computer system's decision algorithm can use a temperature index calculated as the ratio of the low frequency components of the first derivative signal to the low frequency components of the standard deviation values. Exemplary index values as a function of time are shown in FIG. 7E. As shown, the temperature index can be positive after meal intake episodes. Time periods with index values below a threshold amount can be excluded as not involving meal intake. Time periods with index values greater than or equal to the threshold can be interpreted as meal intake by the user or, as discussed below, can be used in conjunction with other data to make such an interpretation. In some embodiments, the threshold amount can be about -0.35 . Accordingly, a positive slope based index can be used to determine from the temperature sensor data whether digestion is occurring.

[0093] Accelerometers

[0094] The one or more sensors can include an accelerometer configured to sense or detect movement of one or more portions of the user. The accelerometer can generate an output signal that represents the user's movements as a function of time. In some embodiments, the accelerometer can have a sampling rate of about 30 Hz. Exemplary accelerometers include the GT3+ monitor 3D accelerometer available from Actigraph, LLC.

[0095] The accelerometer can be coupled to, or configured to measure, movement of various portions of the user. For example, as shown in FIG. 1, 3D-axis accelerometers 120 can be embedded into devices worn at the wrist, e.g., such that a first accelerometer is coupled to the user's left wrist and a second accelerometer is coupled to the user's right wrist. In other embodiments, a single accelerometer can be used. Accelerometers can also be coupled to other portions of the user, such as the user's jaw or throat.

[0096] The accelerometer output can be received by the computer system 106 and can be conditioned and otherwise processed to detect meal intake by the user. The computer system 106 can analyze the sensor output in segments that correspond to discrete windows of time. For example, the computer system 106 can record the sensor output for a predetermined time period (e.g., 10 seconds, 30 seconds, 1 minute, 5 minutes, 10 minutes, etc.) and, at the conclusion of the predetermined time period or thereafter, analyze the sensor output corresponding to that time period.

[0097] FIG. 8A illustrates an exemplary raw output signal generated by the accelerometers and communicated to the computer system 106. The illustrated signals include a time period during which meal ingestion occurred and, as shown, a discernable pattern of motion occurs during meal intake. The 3D information contained in the accelerometer output is shown in FIG. 8B. A principal component analysis (PCA) can be used to project the 3D-axis components into orthogonal bases with minimal correlation, as also shown in FIG. 8B. The PCA components can be used to extract the motion pattern by applying a band-pass FIR filter (e.g., 0.1-0.3 Hz) to the PCA components, as shown in FIG. 8C. The energy of these filtered signals can then be computed as shown in FIG. 8D and, from that information, the total energy above a heuristically-defined threshold (e.g., about 4.0) can be computed to produce an index for the computer system's decision algorithm, as shown in FIG. 8E.

[0098] Time periods with index values below a threshold index amount can be excluded as not involving meal intake. Time periods with index values greater than or equal to the

threshold can be interpreted as meal intake by the user or, as discussed below, can be used in conjunction with other data to make such an interpretation. In some embodiments, the threshold amount can be about 13,767. Accordingly, energy in a frequency band of interest can be used as an index to determine from the accelerometer output when meal intake activities are occurring.

[0099] Electrogastrographs (EGG)

[0100] The one or more sensors can include an electrogastrograph (“EGG”) or an electrogastroenterograph configured to sense or detect electrical activity of the user’s gastrointestinal system (e.g., stomach, small intestine, colon, and so forth). The electrogastrograph can generate an output signal that represents electrical activity as a function of time. The electrogastrograph can include surface leads or electrodes configured for attachment to the user’s skin and/or implantable leads or electrodes configured to be placed within the user. In some embodiments, the electrogastrograph can have a sampling rate of about 312.5 Hz. Exemplary electrogastrographs include the Biopac MP150 Data Acquisition System and the Biopac EGG100C available from Biopac Systems, Inc.

[0101] The electrogastrograph electrodes can be coupled to, or configured to measure, various portions of the user. For example, as shown in FIG. 1, the electrogastrograph electrodes 122 can be coupled to various places on the user’s abdomen.

[0102] The electrogastrograph output can be received by the computer system 106 and can be conditioned and otherwise processed to detect meal intake by the user. The computer system 106 can analyze the sensor output in segments that correspond to discrete windows of time. For example, the computer system 106 can record the sensor output for a predetermined time period (e.g., 10 seconds, 30 seconds, 1 minute, 5 minutes, 10 minutes, etc.) and, at the conclusion of the predetermined time period or thereafter, analyze the sensor output corresponding to that time period.

[0103] FIG. 9A illustrates an exemplary raw output signal generated by the electrogastrograph and communicated to the computer system 106. In some embodiments, the local energy of the electrogastrograph output filtered in a frequency zone of interest can be used as an index for the computer system’s decision algorithm. The computer system 106 can filter the EGG output in the frequency domain of the intestine (e.g., 0.01-0.03 Hz), as shown in FIG. 9B. A saturation can be applied on the filtered signal to reduce motion-induced artifacts, as shown in FIG. 9C. The sliding energy of the cropped-filtered signals can then be computed and the total energy can be used as an index.

[0104] Time periods with index values below a threshold amount can be excluded as not involving meal intake. Time periods with index values greater than or equal to the threshold can be interpreted as meal intake by the user or, as discussed below, can be used in conjunction with other data to make such an interpretation. In some embodiments, the threshold amount can be about 0.015. Accordingly, an amplitude-based index can be used to determine from the electrogastrograph output whether digestion is occurring.

[0105] Impedance Sensors

[0106] The one or more sensors can include an impedance sensor configured to sense or measure the impedance across one or more portions of the user’s body. The impedance sensor can generate an output signal that represents the impedance as a function of time. The impedance sensor can

include surface leads or electrodes configured for attachment to the user’s skin and/or implantable leads or electrodes configured to be placed within the observed portion of the user, e.g., in the form of needles or wires. In some embodiments, the impedance sensor can have a sampling rate of about 312.5 Hz. Exemplary impedance sensors include the Biopac MP150 Data Acquisition System and the Biopac EB1100C available from Biopac Systems, Inc.

[0107] The impedance sensor electrodes can be coupled to, or configured to measure, various portions of the user. For example, as shown in FIG. 1, the impedance sensor electrodes 124 can be coupled to the user’s neck. Each time a bolus of ingested solids or liquids passes through the user’s neck, a change in impedance can be observed. As shown in FIG. 10A, respiration and chewing artifacts can also be observed in the impedance sensor output.

[0108] The impedance sensor output can be received by the computer system 106 and can be conditioned and otherwise processed to detect meal intake by the user. The computer system 106 can analyze the sensor output in segments that correspond to discrete windows of time. For example, the computer system 106 can record the sensor output for a predetermined time period (e.g., 10 seconds, 30 seconds, 1 minute, 5 minutes, 10 minutes, etc.) and, at the conclusion of the predetermined time period or thereafter, analyze the sensor output corresponding to that time period.

[0109] FIG. 10A illustrates an exemplary raw output signal generated by the impedance sensor, with inset portions showing the output during chewing and during respiration. The output signal can be communicated to the computer system 106, which can use an energy-based index to determine when ingestion is occurring. The computer system 106 can apply a band-pass FIR filter on the impedance-measurement signals. The chewing band can be fixed between, e.g., 1.5 to 2.5 Hz. The median energy in the frequency range of interest can be used as an index for the computer system’s decision algorithm. The estimated energy as a function of time is shown in FIG. 10B, in which meal intake began at $T=360$ s. As shown, estimated energy peaks coincide with meal intake.

[0110] Time periods with index values below a threshold amount can be excluded as not involving meal intake. Time periods with index values greater than or equal to the threshold can be interpreted as meal intake by the user or, as discussed below, can be used in conjunction with other data to make such an interpretation. In some embodiments, the threshold amount can be about 1.4×10^{-5} . Accordingly, an energy-based index can be used to determine from the impedance sensor output when chewing occurs.

[0111] Impedance of other portions of the user’s body can also be sensed including, for example, the impedance across the user’s stomach wall. Sensing and processing gastric impedance data and/or using changes in gastric impedance to detect eating is described in more detail in U.S. Pat. Pub. No. 2009/0192404 filed Jan. 28, 2008 entitled “Methods And Devices For Measuring Impedance In A Gastric Restriction System,” Silny et al, “Verification of the intraluminal multiple electrical impedance measurement for the recording of gastrointestinal motility,” *Neurogastroenterology & Motility*, Vol 5(2): 107-122 (June 1993); and “Effects of Thickened Feeding on Gastroesophageal Reflux in Infants: A Placebo-Controlled Crossover Study Using Intraluminal Impedance,” *Pediatrics* 111(4), e355-e359 (April 2003).

[0112] FIGS. 11A-11F illustrate various exemplary patterns in which the impedance sensor electrodes can be coupled to the user.

[0113] In FIG. 11A, the I- and I+ electrodes are coupled to opposite sides of the user's throat, just beneath the jaw. The V- and V+ electrodes are coupled to opposite sides of the user's neck, at the base of the neck, just above the clavicle and in front of the trapezius.

[0114] In FIG. 11B, the I- and I+ electrodes are coupled to the user's right and left trapezius muscles, respectively, about half way between the user's neck and shoulder. The V- and V+ electrodes are coupled to opposite sides of the user's chest, just below the clavicle and about half way between the user's neck and shoulder.

[0115] In FIG. 11C, the I- and I+ electrodes are coupled to opposite sides of the user's chest, just below the clavicle and about half way between the user's neck and shoulder. The V- and V+ electrodes are coupled to opposite sides of the user's chest, just beneath the I- and I+ electrodes and inward towards the sternum.

[0116] In FIG. 11D, the I- and I+ electrodes are coupled to the user's right and left trapezius muscles, respectively, about half way between the user's neck and shoulder. The V- and V+ electrodes are coupled to opposite sides of the user's chest, beneath the clavicle and closer to the sternum than to the shoulder.

[0117] In FIG. 11E, the I- and I+ electrodes are coupled to opposite sides of the user's back, just below the base of the neck. The V- and V+ electrodes are coupled to opposite sides of the user's chest, just below the clavicle and about half way between the user's neck and shoulder.

[0118] In FIG. 11F, the I- and I+ electrodes are coupled to opposite sides of the user's back, just below the base of the neck. The V- and V+ electrodes are coupled to the user's right and left trapezius muscles, respectively, about half way between the user's neck and shoulder.

[0119] The output graphs that accompany each electrode placement diagram illustrate exemplary impedance power spectral density (PSD) as detected by the impedance sensor during chewing and non-chewing episodes. As shown, the electrode placement of FIGS. 11A-11C can provide a PSD of about 0.05 at 1.5 Hz during chewing episodes, which can be readily distinguished from non-chewing episodes. The electrode placement of FIGS. 11D-11F can result in less of a distinction in the sensor output between chewing and non-chewing episodes. While the electrode placement of FIG. 11A can provide the strongest response to chewing episodes, the electrode placement of FIGS. 11B-11C can be preferred in some embodiments, as these placements can be easily hidden under the user's clothing and also provide a strong response to chewing episodes. It will be appreciated that a variety of other electrode placements can be used in addition to those specifically illustrated and described herein.

[0120] Heart Rate Sensors

[0121] While ECG sensors are disclosed above for detecting the user's heart rate, it will be appreciated that other heart rate sensors can be used instead or in addition. Heart rate sensors can be configured to gather heart rate data for the user, including changes in heart rate, e.g., HRV. Heart rate sensors can be subcutaneously positioned or implanted within the user, e.g., at the distal esophagus, the proximal stomach, or the mid/distal stomach. Heart rate sensors can also be transcutaneously positioned or positioned external to the user such as positioned on an external skin surface thereof. One or more

heart rate sensors can be disposed at a variety of locations around the user, e.g., the wrist and the sternum, and each of the heart rate sensors can be configured to communicate sensed data to the computer system 106.

[0122] Externally-located heart rate sensors can include a strap configured to be worn by the user such that a heart rate sensing electrode attached to the strap is positioned on an exterior skin surface of a chest of the user, a heart rate sensing electrode attached to an article of clothing configured to be worn by the user such that the electrode contacts an exterior skin surface of the user, and a pulse oximeter configured to be positioned on an external skin surface of a finger of a user. Exemplary embodiments of a heart rate sensor configured to be positioned within the user include a lead configured to be implanted within a heart of the user, and an electrode configured to be implanted on a thorax of the user.

[0123] pH Sensors

[0124] The one or more sensors can include a pH sensor configured to gather digestive tract pH levels of the user, e.g., pH levels within the user's stomach. A pH sensor can be implanted in the user, such as within a gastrointestinal tract of the user, e.g., within the user's stomach, within the user's intestine, within the user's mouth (e.g., a dental implant), etc.

[0125] Variations in gastric pH can indicate whether or not there is solid food present in the stomach. The relationship between gastric pH levels and food consumption is described in further detail in "Regional Postprandial Differences in pH Within the Stomach and Gastroesophageal Junction," *Digestive Diseases and Sciences*, Vol. 50, No. 12 (December 2005), pgs. 2276-2285. Using intraluminal pH sensors to detect eating is described in more detail in "Effects of Thickened Feeding on Gastroesophageal Reflux in Infants: A Placebo-Controlled Crossover Study Using Intraluminal Impedance," *Pediatrics* 111(4), e355-e359 (April 2003). In general, gastric pH is low in an empty stomach. Upon eating, especially foods that contain protein, gastric pH can become more basic (i.e., the pH value increases) due to buffering by the food. The increase in pH can occur even though the stomach is actively secreting acid. Once the buffering capacity of the food is exceeded, the gastric pH can return to a low value. Thus, as described in further detail in U.S. Pat. Pub. No. 2009/0192534 filed Jan. 29, 2008 entitled "Sensor Trigger" and in "Regional Postprandial Differences in pH Within the Stomach and Gastroesophageal Junction," *Digestive Diseases and Sciences*, Vol. 50, No. 12 (December 2005), the gastric pH level can increase after each meal and return to the baseline pH sometime thereafter.

[0126] The pH sensor can be configured to communicate the sensed data to the computer system 106. The computer system 106 can in turn be configured to determine whether a change in gastric pH of a selected magnitude occurred, e.g., |X-Y| pH, or whether the pH rises above a threshold value, e.g., above about 7. Time periods in which the pH exceeds the threshold or in which pH changes of a selected magnitude occur can be interpreted as meal intake by the user or, as discussed below, can be used in conjunction with other data to make such an interpretation. Accordingly, gastric pH sensors can be used to determine when digestion occurs.

[0127] Gastric Stretch Sensors

[0128] In some embodiments, the one or more sensors can include a gastric stretch sensor, e.g., a strain gauge and strap disposed around the user's abdomen. Various embodiments of collecting and/or analyzing gastric stretch data to determine when eating occurs are described in more detail in Paintal, et al., "A Study Of Gastric Stretch Receptors: Their

Role In The Peripheral Mechanisms Of Satiation Of Hunger And Thirst," *Journal of Physiology*, Vol. 126, 255-270 (1954), and Geliebter et al., "Gastric Distension By Balloon And Test-Meal Intake In Obese And Lean Subjects," *Am J Clin Nutr*, Vol 48, 592-594 (1988).

[0129] Combinations of Sensors

[0130] As noted above, the computer system 106 can be configured to make a meal intake determination based on the output of a single sensor or based on the output of a plurality of sensors. A number of exemplary sensor combinations are discussed below, however it will be appreciated that virtually any combination of the sensors described herein can be used.

[0131] As shown in FIG. 12, the EMG and impedance sensors can have high sensitivity and high specificity when distinguishing between solid food intake and other activities such as drinking, resting, and exercising. The accelerometer and microphone sensors can have high sensitivity and high selectivity when distinguishing between solid or liquid food intake and other activities such as resting and exercising. The temperature, HRV, and EGG sensors can have relatively lower sensitivity and/or specificity when determining when digestion is occurring.

[0132] In some embodiments, the one or more sensors can include an EMG sensor and an accelerometer, and can be effective to detect solid and liquid food intake with high specificity and high sensitivity. For example, the computer system 106 can be configured to detect that solid food intake occurs when the EMG sensor exceeds the index threshold. The computer system 106 can be configured to detect that drinking occurs when the EMG sensor is below the index threshold and the accelerometer is above the index threshold. When neither sensor is above the index threshold, the computer system 106 can determine that no solid food intake or drinking is occurring.

[0133] In some embodiments, the one or more sensors can include an impedance sensor and an accelerometer, and can be effective to detect solid and liquid food intake with high specificity and high sensitivity. For example, the computer system 106 can be configured to detect that solid food intake occurs when the impedance sensor exceeds the index threshold. The computer system 106 can be configured to detect that drinking occurs when the impedance sensor is below the index threshold and the accelerometer is above the index threshold. When neither sensor is above the index threshold, the computer system 106 can determine that no solid food intake or drinking is occurring.

[0134] In some embodiments, the one or more sensors can include an EMG sensor and a microphone, and can be effective to detect solid and liquid food intake with high specificity and high sensitivity. For example, the computer system 106 can be configured to detect that solid food intake occurs when the EMG sensor exceeds the index threshold. The computer system 106 can be configured to detect that drinking occurs when the EMG sensor is below the index threshold and the microphone is above the index threshold. When neither sensor is above the index threshold, the computer system 106 can determine that no solid food intake or drinking is occurring.

[0135] In some embodiments, the one or more sensors can include an impedance sensor and a microphone, and can be effective to detect solid and liquid food intake with high specificity and high sensitivity. For example, the computer system 106 can be configured to detect that solid food intake occurs when the impedance sensor exceeds the index threshold and the microphone exceeds the index threshold. The

computer system 106 can be configured to detect that drinking occurs when the impedance sensor is below the index threshold and the microphone is above the index threshold. When neither sensor is above the index threshold, the computer system 106 can determine that no solid food intake or drinking is occurring.

[0136] As shown in FIG. 13, sensor combinations can advantageously allow solid food intake and drinking to be distinguished from other activities such as resting and exercising with high sensitivity and specificity.

[0137] Controlled Devices

[0138] As noted above, a controlled device 108 can be coupled to the meal detection system 100 such that the meal detection system is configured to trigger, modulate, or otherwise control the controlled device 108 based on determinations made by the computer system 106. In particular, when the computer system 106 determines that meal intake has occurred or is presently occurring, it can trigger, modulate, or otherwise control one or more controlled devices 108.

[0139] The computer system 106 can be configured to transmit a trigger signal to the controlled device 108. The trigger signal can have a variety of configurations, such as a simple on/off signal configured to change the controlled device 108 from a dormant or off mode, in which the controlled device 108 does not deliver therapy or record that meal intake has occurred, to a delivery or on mode in which the controlled device 108 delivers a therapy to the user or records that meal intake has occurred. The trigger signal can trigger a timer at the controlled device 108 that can initiate delivery of a therapy after a predetermined period of time has passed, e.g., 15 minutes, etc., such that the therapy can be initiated a certain amount of time after the detection of a meal has occurred. The trigger signal can optionally include data related to the meal ingested by the user, e.g., an amount or estimated amount of food eaten. The controlled device 108 can be configured to record this data for subsequent analysis or reporting. Alternatively or in addition, the controlled device 108 can be configured to use such data to determine an amount of therapy to deliver to the user, e.g., a certain volume of chemical to be delivered thereto, and/or a length of time to deliver the therapy to the user. The computer system 106 can be configured to include with the trigger signal instructions regarding the amount of the therapy to deliver to the user and/or the length of time to deliver the therapy to the user. In some embodiments, after transmitting the trigger signal to the controlled device 108, the computer system 106 can be configured to transmit a second, subsequent trigger signal to the controlled device 108 to cause the device to stop delivering the therapy to the user. The second, subsequent trigger signal can be sent for any number of reasons, such as after a certain period of time or if, based on sensed data gathered by the at least one sensor 104, the computer system 106 determines that the user has ceased meal intake.

[0140] Upon receipt of the trigger signal, the controlled device 108 can be configured to deliver a therapy to the user for any length of time. In some embodiments, the trigger signal can be configured to trigger delivery of the therapy for an indefinite period of time. In other words, the controlled device 108 can be configured to have a default off mode in which the device does not deliver the therapy to the user, and be configured to permanently switch to an on mode during which the device 108 delivers the therapy to the user. The indefinite period of time can be established by an amount of the therapy available to the device 108, e.g., if the device 108

includes a finite supply of a chemical therapy, can be defined by an amount of power available to the device **108**, e.g., battery life, and/or can be defined by a likely-unknown period of time before a predetermined termination event occurs that triggers an end of the therapy's delivery to the user. The predetermined termination event can include, e.g., an end of a meal intake episode as determined by the computer system **106** and communicated from the computer system to the controlled device **108**. In other embodiments, the trigger signal can be configured to trigger delivery of the therapy for a predetermined time period, e.g., a period of "N" seconds, minutes, etc. in which the device **108** is configured to deliver the therapy to the user before stopping delivery thereof if and until the computer system **106** communicates another trigger signal to the device **108** to again start delivery of the therapy.

[0141] The device **108** can therefore be configured to intermittently deliver the therapy to the user. In other words, the device can be configured to have a default off mode in which the device does not deliver therapy to the user, and be configured to change from the off mode to an on mode for the predetermined time period during which the device delivers the therapy to the user before returning to the off mode. Further, triggering delivery of the therapy at generally unpredictable intervals, e.g., whenever the user ingests a meal, can help prevent the user's body from adapting to a particular therapy by learning to expect the therapy at certain times.

[0142] The controlled device **108** can be defaulted to a dormant mode until triggered by detected meal intake. Various exemplary embodiments of devices having a dormant mode, as well as various exemplary embodiments of powering a system including a sensor and of transmitting signals, are described in further detail in U.S. Pat. Pub. No. 2010/0056948 filed Aug. 25, 2009 entitled "Stimulation Of Satiety Hormone Release" and U.S. Pat. Pub. No. 2009/0192404 filed Jan. 28, 2008 entitled "Methods And Devices For Measuring Impedance In A Gastric Restriction System." Exemplary controlled devices are disclosed in U.S. Pat. Pub. No. 2012/0172792 filed Dec. 29, 2010 entitled "Obesity Therapy And Heart Rate Variability."

[0143] Electrical Stimulation

[0144] In some embodiments, the controlled device **108** can be configured to deliver electrical stimulation to the user's tissue, e.g., a stomach wall of the user, an intestinal wall of the user, individual nerves or nerve bundles innervating a target tissue of interest, etc., e.g., for the treatment of obesity and/or co-morbidities.

[0145] Because the controlled device **108** can be configured to intermittently deliver stimulation therapy to the user only when triggered by detected meal intake, nerve and/or tissue desensitization to electrical signals and nerve and/or tissue damage can be reduced, if not entirely prevented, because the electrical signal is not continuously delivered to the nerve and/or tissue. Moreover, when triggered to begin delivery of the stimulation therapy by the computer system **106**, the controlled device **108** can be configured to non-continuously deliver the electrical signal to the user such that the signal is alternately "off" and "on" when the controlled device **108** is in the on mode. The periods of time in which the signal is "off" and "on" can be the same or different from one another. In exemplary embodiments, the signal can be "off" for a longer period of time than it is "on," which can help reduce, if not prevent, nerve and/or tissue desensitization to electrical signals and nerve and/or tissue damage. Delivering an electrical signal that is "off" for a longer period of time

than it is "on" can also help conserve power, e.g., reduce battery consumption, and can reduce the size of a power supply required to power the controlled device **108**. However, the controlled device **108** can be configured to continuously deliver the electrical signal to the user, e.g., continuously delivered indefinitely or continuously delivered during a predetermined time period of "N" minutes after the computer system **106** triggers the controlled device **108**.

[0146] The electrical signal can be applied to more than one location on tissue, e.g., gastrointestinal tissue, of the user. For example, the electrical signal can be applied to two, three, four, or more locations in a distal ileum of the user. A "location" can be defined by the area of physical contact between the tissue and a means for delivery of the electrical stimulus, e.g., a first electrode of the controlled device **108**. Accordingly, the application of the electrical signal to a second location on the tissue of the user can include contacting a second electrode of the controlled device **108** with a portion of the tissue that is not in physical contact with the first electrode also electrically stimulating the user.

[0147] The electrical signal can have a variety of configurations. Exemplary electrical parameters of the electrical signal that can be varied include frequency, voltage, current, and pulse duration. The electrical signal can have a frequency of about 0.1 Hz to about 90 Hz; for example, the electrical signal can have a frequency of about 0.1 Hz, about 0.15 Hz, about 0.2 Hz, about 0.4 Hz, about 1 Hz, about 4 Hz, about 10 Hz, about 20 Hz, about 25 Hz, about 30 Hz, about 35 Hz, about 40 Hz, about 50 Hz, about 70 Hz, or about 90 Hz. The electrical signal can have a voltage of about 0.5 V to about 25 V; for example, the voltage can be about 1 V, about 2 V, about 5 V, about 10 V, about 14V; about 15 V, about 20 V, or about 25 V. The electrical signal can have a current between about 2 mA and about 10 mA. The electrical signal can have a pulse duration of about 3 ms to about 500 ms; for example, the pulse duration may be about 5 ms, about 50 ms, about 100 ms, about 150 ms, about 200 ms, about 250 ms, about 300 ms, about 350 ms, about 400 ms, about 450 ms, or about 500 ms. In some embodiments, the electrical signal can be applied at a voltage of about 14V, with a pulse duration of about 5 ms, and at a stimulus frequency of about 20 to about 80 Hz; with respect to such embodiments, the stimulus frequency can be, for example, about 20 Hz, about 40 Hz, or about 80 Hz. In other embodiments, the electrical signal can be applied at a voltage of about 14 V, with a pulse duration of about 300 ms, and at a frequency of about 0.4 Hz. Various exemplary embodiments of an electrical signal that can be delivered to a user are described in more detail in U.S. Pat. Pub. No. 2010/0056948 filed Aug. 25, 2009 entitled "Stimulation Of Satiety Hormone Release."

[0148] An electrical signal can be delivered to the user in any number of ways to electrically stimulate the user. FIG. 14 illustrates an exemplary embodiment of a controlled device **1100** configured to generate and deliver an electrical signal to a user. Although the illustrated controlled device **1100** is implantable, a controlled device configured to deliver electrical stimulation to a user can be subcutaneously or transcutaneously positioned, as mentioned above. The controlled device **1100** can include a housing **1102** coupled to a suitable power source or battery **1104**, such as a lithium battery, a first waveform generator **1106**, and a second waveform generator **1108**. As in the illustrated embodiment, the battery **1104** and first and second waveform generators can be located within the housing **1102**. In other embodiments, a battery can be

external to a housing and be wired or wirelessly coupled thereto. The housing **1102** is preferably made of a biocompatible material. The first and second waveform generators **1106**, **1108** can be electrically coupled to and powered by the battery **1104**. The waveform generators **1106**, **1108** can be of any suitable type, such as those sold by Texas Instruments of Dallas, Tex. under model number NE555. The first waveform generator **1106** can be configured to generate a first waveform or low frequency modulating signal **1108**, and the second waveform generator **1110** can be configured to generate a second waveform or carrier signal **1112** having a higher frequency than the first waveform **1108**. Low frequency modulating signals cannot, in and of themselves, pass through body tissue to effectively stimulate target nerves. The second waveform **1108** can, however, to overcome this problem and penetrate through body tissue. The second waveform **1112** can be applied along with the first waveform **1108** to an amplitude modulator **1114**, such as the modulator having the designation On-Semi MC1496, which is sold by Texas Instruments.

[0149] The modulator **1114** can be configured to generate a modulated waveform **1116** that is transmitted through a lead **1118** to one or more electrodes **1120**. Four electrodes are illustrated, but the device **1100** can include any number of electrodes having any size and shape. The lead **1118** can be flexible, as in the illustrated embodiment. The electrodes **1120** can be configured to, in turn, apply the modulated waveform **1116** to a target tissue or nerve **1122** to stimulate the target **1122**. The first and second waveforms **1108**, **1112** can have any shape, e.g., the first waveform **1108** can be a square wave, and the second waveform **1112** can be a sinusoidal signal. Although an electrical signal is described that includes carrier and modulating signals, an electrical signal delivered to a user can alternatively include only one of a carrier and modulating signal.

[0150] Various exemplary embodiments of methods and devices for delivering an electrical signal to a user are described in more detail in U.S. Pat. Pub. No. 2011/0270360, filed on Dec. 29, 2010 entitled "Methods And Devices For Activating Brown Adipose Tissue," U.S. Pat. Pub. No. 2009/0132018 filed Nov. 16, 2007 entitled "Nerve Stimulation Patches And Methods For Stimulating Selected Nerves," U.S. Pat. Pub. No. 2010/0056948 filed Aug. 25, 2009 entitled "Stimulation Of Satiety Hormone Release," U.S. Pat. Pub. No. 2008/0147146 filed Dec. 19, 2006 entitled "Electrode Patch And Method For Neurostimulation," U.S. Pat. Pub. No. 2005/0277998 filed Jun. 7, 2005 entitled "System And Method For Nerve Stimulation," U.S. Pat. Pub. No. 2006/0195153 filed Jan. 31, 2006 entitled "System And Method For Selectively Stimulating Different Body Parts," U.S. Pat. Pub. No. 2007/0185541 filed Aug. 2, 2006 entitled "Conductive Mesh For Neurostimulation," U.S. Pat. Pub. No. 2006/0195146 filed Jan. 31, 2006 entitled "System And Method For Selectively Stimulating Different Body Parts," U.S. Pat. Pub. No. 2008/0132962 filed Dec. 1, 2006 entitled "System And Method For Affecting Gastric Functions," U.S. Pat. Pub. No. 2008/0147146 filed Dec. 19, 2006 entitled "Electrode Patch And Method For Neurostimulation," U.S. Pat. Pub. No. 2009/0157149 filed Dec. 14, 2007 entitled "Dermatome Stimulation Devices And Methods," U.S. Pat. Pub. No. 2009/0149918 filed Dec. 6, 2007 entitled "Implantable Antenna," U.S. Pat. Pub. No. 2009/0132018 filed Nov. 16, 2007 entitled "Nerve Stimulation Patches And Methods For Stimulating Selected Nerves," U.S. Pat. Pub. No. 2010/0161001 filed Dec. 19, 2008 entitled "Optimizing The Stimulus Current In A

Surface Based Stimulation Device," U.S. Pat. Pub. No. 2010/0161005 filed Dec. 19, 2008 entitled "Optimizing Stimulation Therapy Of An External Stimulating Device Based On Firing Of Action Potential In Target Nerve," U.S. Pat. Pub. No. 2010/0239648 filed Mar. 20, 2009 and entitled "Self-Locating, Multiple Application, And Multiple Location Medical Patch Systems And Methods Therefor," and U.S. Pat. Pub. No. 2011/0094773 filed Oct. 26, 2009 entitled "Offset Electrodes."

[0151] Various exemplary embodiments of devices configured to directly apply an electrical signal to stimulate nerves are described in more detail in U.S. Pat. Pub. No. 2005/0177067 filed Jan. 26, 2005 entitled "System And Method For Urodynamic Evaluation Utilizing Micro-Electronic Mechanical System," U.S. Pat. Pub. No. 2008/0139875 filed Dec. 7, 2006 entitled "System And Method For Urodynamic Evaluation Utilizing Micro Electro-Mechanical System Technology," U.S. Pat. Pub. No. 2009/0093858 filed Oct. 3, 2007 entitled "Implantable Pulse Generators And Methods For Selective Nerve Stimulation," U.S. Pat. Pub. No. 2010/0249677 filed Mar. 26, 2010 entitled "Piezoelectric Stimulation Device," U.S. Pat. Pub. No. 2005/0288740 filed Jun. 24, 2004 entitled "Low Frequency Transcutaneous Telemetry To Implanted Medical Device," U.S. Pat. No. 7,599,743 filed Jun. 24, 2004 entitled "Low Frequency Transcutaneous Energy Transfer To Implanted Medical Device," U.S. Pat. No. 7,599,744 filed Jun. 24, 2004 entitled "Transcutaneous Energy Transfer Primary Coil With A High Aspect Ferrite Core," U.S. Pat. No. 7,191,007 filed Jun. 24, 2004 entitled "Spatially Decoupled Twin Secondary Coils For Optimizing Transcutaneous Energy Transfer (TET) Power Transfer Characteristics," and European Pat. Pub. No. 377695 published as Int'l. Pat. Pub. No. WO1989011701 published Nov. 30, 2004 and entitled "Interrogation And Remote Control Device."

[0152] Drug Delivery

[0153] The controlled device **108** can be configured to administer a therapeutic agent, e.g., a natural or an artificial chemical, solution, active ingredient, nutrient, drug, medicant, nutraceutical, or pharmaceutical to a user.

[0154] The therapeutic agent can be delivered to the user in any number of ways. FIG. **15** illustrates one exemplary embodiment of a controlled device **108** in the form of a delivery device **212**, e.g., an active agent catheter delivery system, configured to deliver a therapeutic agent to a user. The delivery device **212** is shown implanted within an intestine of a user, but the delivery device **212** can be implanted in a variety of locations and can be implanted in a variety of ways, e.g., implanted laparoscopically, deployed within the colon through a natural orifice procedure, etc. Various exemplary embodiments, including the delivery device **212**, of methods and devices for delivering a therapeutic agent to a user are described in more detail in U.S. Pat. Pub. No. 2005/0038415 filed Jul. 12, 2004 entitled "Method And Apparatus For Treatment Of Obesity."

[0155] Generally, the delivery device **212** can include an active agent reservoir and pump **210** and an active agent delivery catheter **220**. Although any active agent reservoir and pump and active agent delivery catheter can be used, an exemplary embodiment of an active agent reservoir and pump includes a MEDSTREAM™ Programmable Infusion Pump, available from Codman & Shurtleff, Inc. of Raynham, Mass., and an exemplary embodiment of an active agent delivery catheter includes a Codman® silicone tapered arterial catheter, available from Codman & Shurtleff, Inc. The reservoir

and pump **210** can include any suitable reservoir and/or fluid delivery pump, e.g., having, as shown in FIG. 16, a resealable fluid insertion boss **213**, a fluid reservoir **211**, a fluid pump **214**, and a radially extended male fluid delivery port **215**.

[0156] In use, a therapeutic agent contained in the reservoir **211** can be dispensed therefrom, through the catheter **220**, (e.g., into the ileum of the user in order to decrease intestinal motility and increase feelings of satiety experienced by the user). Optionally, the reservoir **211** can be recharged at any time necessary. Preferably, recharging of the reservoir **211** is performed without removal from the implantation site but is performed transcatheterally such as, for example, by injection with a syringe. The active agent delivery catheter **220**, as shown in FIG. 17, can include a female port **221** positioned at a first terminal end of catheter **220** and configured to mate with the male fluid delivery port **215** of the reservoir and pump **210**. The catheter **220** can include an elongate fluid transmission lumen **222** extending from the female port **221** to a second terminal end of the catheter **220**. Positioned near the second terminal end of the catheter **220** and around a circumference of the lumen **222** can be a first laterally extending brace **223**. A second laterally extending brace **224** can be positioned distally to the first laterally extending brace **223** in close proximity to the second terminal end of the catheter **220**. The catheter **220** can also include a balloon **225** configured to secure the catheter **220** within, e.g., the user's abdominal cavity, wherein a securing means, such as a row of purse-string sutures, can be placed and tightened around an opening in the intestine to secure the intestine to the catheter **220**. The balloon **225** can then be pulled taut against the sealing means to prevent leakage of intestinal contents.

[0157] Ileal Brake Nutrients

[0158] The controlled device **108** can be configured to administer any substance (e.g., a nutrient) configured to provoke a release of one or more hormones from L-cells, such as linoleic acid (LA), a carbohydrate, other sugars, an amino acid, a protein, a fatty acid, a fat, or any combination thereof. The nutrient can take the form of a natural food item; a supplement, e.g., a nutrition drink; or a substance that is made with the express purpose of stimulating L-cells, and therefore need not be a "nutrient" per se in the conventional sense. Generally, delivery of the nutrient to the user, such as to the user's intestine, e.g., an ileum of the intestine, can help trigger ileal brake. Normally, the presence of nutrients, which arise from a meal consisting of carbohydrates, fats and proteins, termed "digesta" in the digestive tract, stimulates release of the body's own incretins into the blood stream. Key hormones, released by specialized L-cells located in the mucosa, which is the innermost interior (luminal) wall of the intestines, coordinate the body's response to a meal. The hormones produce this effect by inducing a sense of fullness and cessation of eating (satiety), triggering the release of insulin to maintain proper glucose levels (incretin effect) and slowing the passage of contents through the digestive tract (delaying gastric emptying and slowing small intestinal transit). Collectively, these effects have been termed the ileal brake. By delivering the nutrient, e.g., triggering ileal brake, at the onset of the user ingesting a meal, satiation can occur earlier than it would in a normal digestive process without the delivery of the nutrient to the user. The user can therefore feel full faster after beginning to eat, thereby encouraging smaller amounts of food intake and, over time, encouraging weight loss. Triggering ileal brake and various exemplary embodiments of nutrients and administration thereof to a user to help treat

obesity are described in more detail in U.S. Pat. Pub. No. 2010/0056948 filed Aug. 25, 2009 entitled "Stimulation Of Satiety Hormone Release."

[0159] Insulin

[0160] The controlled device **108** can be an insulin pump, continuous glucose meter, or artificial pancreas. Meal detection using the meal detection system **100** described herein can be used with the insulin pump or artificial pancreas to control insulin release, instead of or in addition to the continuous blood glucose sensors that are typically used. The system **100** can allow for earlier triggering than relying solely on measurement of interstitial glucose. The system **100** can also allow for less frequent blood glucose sampling, allowing for a more dormant duty cycle to increase battery life. The system **100** can detect when exercise is occurring (e.g., by detecting sustained elevated heart rate or repeated body movements consistent with running or exercising), which can be considered in determining the timing and quantity of insulin delivery. The system **100** can also allow for meal size or meal duration to be estimated, and can be used to maintain a log of meal intake for user education, accountability, or awareness. Exemplary insulin pumps and/or artificial pancreases are disclosed in U.S. Pat. No. 4,515,584 issued on May 7, 1985 entitled "Artificial Pancreas"; U.S. Pat. No. 6,023,009 issued on Feb. 8, 2000 entitled "Artificial Pancreas"; and U.S. Pat. No. 8,346,399 issued on Jan. 1, 2013 entitled "Programmable Insulin Pump." It will be appreciated that any of the devices or methods disclosed in the foregoing references can be modified in accordance with the teachings herein to trigger insulin release in response to meal intake detected by the computer system **106**.

[0161] Bile Acid Modulation

[0162] The controlled device **108** can be configured to deliver a composition effective to modulate bile acid levels in the user, e.g., to treat a metabolic disorder. Exemplary methods and devices for modulating bile acid are disclosed in U.S. application Ser. No. 13/631,095, filed on Sep. 28, 2012 and entitled "Methods and Compositions of Bile Acids." It will be appreciated that any of the devices or methods disclosed in the foregoing reference can be modified in accordance with the teachings herein to modulate bile acid levels based on meal intake detected by the computer system **106**.

[0163] pH Therapy

[0164] The controlled device **108** can be configured to deliver a composition, e.g., bicarbonate, effective to modulate pH in the user's stomach or in other portions of the user's digestive tract. For example, the device **108** can be configured to release a composition to increase gastric pH during meal intake when said intake is detected by the computer system **106**. Increasing the pH can prevent certain digestive enzymes responsible for breaking down proteins, such as pepsin, from being activated. In some embodiments, the device **108** can modulate gastric pH during meal intake to a level of at least about 2.4, at least about 3, at least about 5, and/or at least about 7.

[0165] Other Drugs

[0166] The controlled device **108** can be configured to deliver other drugs, including GLP-1 agonists (e.g., exenatide ("Byetta") or liraglutide ("Victoza")), activators of Brown Adipose Tissue (e.g., norepinephrine, etc.), Melanocortin Four Receptor Agonists, and other agents that impact metabolic function.

[0167] Aversive Response

[0168] The controlled device **108** can be configured to cause or provoke an aversive response in the user when the user exceeds a certain threshold of meal intake (e.g., to discourage the user from overeating). The threshold can be defined by meal onset, meal volume, meal content (type of food), intake rate, meal duration, and/or meal conclusion. The aversive therapy can be mechanical, electrical, and/or chemical in nature. Exemplary aversive responses include satiety, upset stomach, vomiting, diarrhea, abdominal cramps, nausea, and audible or visual user notifications. For example, the controlled device **108** can be configured to deliver lithium chloride to the user when the computer system **106** detects that the meal volume or meal duration has exceeded a threshold. The meal volume or duration threshold can be based on a variety of factors, including a normal or prescribed caloric intake for the user. Exemplary devices and methods for creating aversive responses in the form of satiety, upset stomach, vomiting, abdominal cramps, nausea, and audible or visual user notifications are disclosed in International Publication No. WO2009096859 entitled "A Device For Treating Obesity," International Publication No. WO2006034400 entitled "Responsive Gastric Stimulator," International Publication No. WO2006049725 entitled "Surgical Systems And Devices To Enhance Gastric Restriction Therapies," U.S. Pat. Pub. No. 2006/0020298 entitled "Systems and Methods for Curbing Appetite," U.S. Pat. Pub. No. 2004/0147816 entitled "Analysis Of Eating Habits," and International Publication No. WO0226101 entitled "System And Method For The Control Of Behavioral Disorders," respectively.

[0169] GLP-1 Release Stimulation

[0170] The controlled device **108** can be configured to apply mechanical or electrical stimulation to stimulate the release of GLP-1 through L-cells in the small intestines, e.g., to treat type **2** diabetes. Exemplary devices and methods for stimulating GLP-1 release are disclosed in International Application Nos. PCT/EP2012/055795, PCT/EP2012/055834, PCT/EP2012/055798, PCT/EP2012/055844, and PCT/EP2012/055831. It will be appreciated that any of the devices or methods disclosed in the foregoing references can be modified in accordance with the teachings herein to stimulate GLP-1 release in response to meal intake detected by the computer system **106**.

[0171] Brown Adipose Tissue Activation (Bat)

[0172] The controlled device **108** can be configured to activate brown adipose tissue, for example using electrical stimulation as disclosed in U.S. Pat. Pub. No. 2011/0270360, filed on Dec. 29, 2010 entitled "Methods And Devices For Activating Brown Adipose Tissue Using Electrical Energy." The meal detection system **100** can trigger BAT activation immediately after a meal when calories are readily available for consumption in the blood stream, which can improve the effectiveness of the BAT activation. Linking treatment to meal intake can also minimize overall stimulation time, prolonging battery life, allowing for smaller devices, and delaying the body's adaptation to the therapy.

[0173] Gastric Bands

[0174] The controlled device **108** can be a gastric band or a device configured to adjust a gastric band. Adjustable gastric band devices and related methods are disclosed in U.S. Pat. Pub. No. 2009/0204132, filed on Feb. 12, 2008 entitled "Automatically Adjusting Band System." It will be appreciated that any of the devices or methods disclosed in the foregoing reference can be modified in accordance with the

teachings herein to adjust a gastric band based on meal intake detected by the computer system **106**, e.g., to tighten the band or increase the restriction provided by the band when meal intake is detected or when meal intake that exceeds a particular volume or duration threshold is detected.

[0175] Gastric Pacing

[0176] The controlled device **108** can be configured to control the tonal contractions of the stomach to affect one or more physiological parameters. For example, the tonal contractions can be controlled to speed up or slow down gastric emptying, or to induce nausea, satiety, and the like. Exemplary methods and devices for gastric pacing are disclosed in U.S. Pat. No. 8,239,027, issued on Aug. 7, 2012 entitled "Responsive Gastric Stimulator." It will be appreciated that any of the devices or methods disclosed in the foregoing reference can be modified in accordance with the teachings herein to adjust the gastric pacing based on meal intake detected by the computer system **106**.

[0177] Gastric Space Occupying Devices

[0178] The controlled device **108** can be a gastric space and/or volume occupying device (e.g., a gastric balloon) or a device configured to adjust a gastric space and/or volume occupying device. Adjustable gastric balloons and related methods are disclosed in U.S. Pat. No. 8,236,023 issued on Aug. 7, 2012 entitled "Apparatus And Method For Volume Adjustment Of Intra-gastric Balloons." It will be appreciated that any of the devices or methods disclosed in the foregoing reference can be modified in accordance with the teachings herein to adjust a gastric space occupying device based on meal intake detected by the computer system **106**, e.g., to increase the volume of the device when meal intake is detected or when meal intake that exceeds a particular volume or duration threshold is detected.

[0179] Gastric Emptying

[0180] A number of methods and devices have been developed for changing the rate of gastric emptying in a user. Exemplary methods and devices for altering gastric emptying rates include pyloric shuttles, pyloric valves, and electrical stimulation devices for altering pyloric function. Pyloric shuttles are disclosed in U.S. Pat. No. 8,048,169 issued on Nov. 1, 2011 entitled "Pyloric valve obstructing devices and methods." Pyloric valves are disclosed in U.S. Pat. No. 8,182,442 issued on May 22, 2012 entitled "Pyloric valve devices and methods" and in U.S. Publication No. 2012/0259427 filed on Jun. 22, 2012 entitled "Pyloric Valve." Electrical stimulation devices for altering pyloric function are disclosed in International Publication No. WO/2005/041749. Additional details on gastric emptying can be found in Melissa, J., Leventi, A., Klinaki, I, et al. "Alterations of global gastrointestinal motility after sleeve gastrectomy: A prospective study." *Ann Surg* 2012. It will be appreciated that any of the devices or methods disclosed in the foregoing references can be modified in accordance with the teachings herein to adjust a rate of gastric emptying based on meal intake detected by the computer system **106**, e.g., to increase or decrease the rate of gastric emptying when meal intake is detected or when meal intake that exceeds a particular volume or duration threshold is detected.

[0181] Pattern Recording and Recognition

[0182] The controlled device **108** can be configured to record and analyze meal intake patterns and/or issue user reminders. For example, each time the computer system **106** detects that meal intake is occurring, the controlled device **108** can remind the user to test blood glucose. By way of

further example, the controlled device **108** can store a record of the meal intake event. The record can include various information, including the date and time at which meal intake occurred, the sensor data at the time of meal intake (e.g., the user's heart rate, temperature, etc.), the time duration of the meal intake event, the estimated volume of the meal intake event, and so forth.

[0183] The controlled device **108** can use stored records of meal intake events to issue alerts to the user that a threshold amount of meal intake has been exceeded, or that a deviation from a meal intake routine has occurred. In insulin-dependent users, for example, following a certain discipline or meal intake pattern in the user's daily lifestyle can help keep the user's condition under control. Stress, travel, and other things, however, can lead to deviations from this pattern, in which case the controlled device **108** can be configured to alert the user to the deviation (e.g., by emitting a visible or audible alert). A saved history of meal intake events can also be helpful in cases where hyperglycaemia or hypoglycaemia occur, as the user can review their meal intake history on the controlled device **108** to understand what went wrong. Less-independent insulin users can also benefit from meal intake logging, as their caregivers can review and monitor the user's meal intake patterns. In highly-dependent insulin patients (e.g., children) the controlled device **108** can be configured to send an email, text message, or other alert to the patient's caretaker (e.g., parents) who can in turn reinforce timely glucose metering and, if necessary, insulin administration (e.g., by sending instructions or a reminder to the child at school). Generally speaking, meal intake logging and monitoring can provide the user with increased awareness of their meal intake patterns, which can be helpful in treating various conditions including obesity and diabetes.

[0184] The controlled device **108** can also be configured to remind the user to test blood glucose levels, or to provide some other alert, when the computer system **106** detects that exercise has occurred or is occurring (e.g., by detecting an elevated heart rate from the ECG sensor or accelerometer data indicative of exercise).

[0185] Combinations

[0186] It will be appreciated that the controlled device **108** can be configured to perform a combination of any of the functions described above, and/or to deliver a combination of the therapies described above. For example, the controlled device **108** can be configured to deliver both a nutrient and electrical stimulation to the user. As described in further detail in U.S. Pat. Pub. No. 2010/0056948 filed Aug. 25, 2009 entitled "Stimulation Of Satiety Hormone Release," delivering a nutrient to a user and electrically stimulating the user can cause a higher expression of Glucagon-Like Peptide (GLP-1), and hence enhance triggering of ileal brake, than delivery of the nutrient to the user without electrical stimulation. By triggering delivery of the nutrient and the electrical stimulation relatively quickly after meal intake begins through the triggering of the controlled device **108** by the computer system **106**, ileal brake can be further encouraged in a faster fashion than would naturally occur or that would occur if the nutrient was delivered without electrical stimulation. In an exemplary embodiment, and as further discussed in U.S. Pat. Pub. No. 2010/0056948, the electrical signal can be delivered to a tissue of the user contemporaneously with the contacting of L-cells of the tissue with the nutrient delivered to the user. "Contemporaneously" generally means that during at least part of the time that the electrical signal is

being delivered to the tissue, the L-cells are in direct contact with the nutrient. Thus, if the electrical signal is delivered for a total duration of one second, contacting the L-cells with the nutrient stimulus for 5 seconds after the application of the electrical signal and for 0.1 seconds during the application of the electrical signal will be considered to have been contemporaneous with the application of the electrical signal.

[0187] In some embodiments, a nutrient can be orally administered to a user, e.g., the user can swallow a nutrient, e.g., as a pill, a fluid, etc., in conjunction with meal intake, e.g., at a start of a meal. Stimulation of the user's L-Cells can be enhanced by electrical stimulation of the user in the presence of the nutrient, e.g., by the controlled device **108** delivering an electrical signal to the user. In other embodiments, a meal that a user ingests can serve as a stimulus for the user's L-Cells, which can be amplified by triggered delivery of electrical stimulation to the user. Since meals can serve to stimulate L-cell production of GLP-1, when properly timed, the electrical stimulation can begin as the meal transits into the user's duodenum. There is a feed forward signal to the ileum which is responsible for increase in GLP-1 production. This can be enhanced by the presence of electrical stimulation in the intestine.

CONCLUDING REMARKS

[0188] The devices disclosed herein can be designed to be disposed of after a single use, or they can be designed to be used multiple times. In either case, however, the device can be reconditioned for reuse after at least one use. Reconditioning can include any combination of the steps of disassembly of the device, followed by cleaning or replacement of particular pieces, and subsequent reassembly. In particular, the device can be disassembled, and any number of the particular pieces or parts of the device can be selectively replaced or removed in any combination, e.g., electrodes, a battery or other power source, an externally wearable sensor and/or housing therefor, etc. Upon cleaning and/or replacement of particular parts, the device can be reassembled for subsequent use either at a reconditioning facility, or by a surgical team immediately prior to a surgical procedure. Those skilled in the art will appreciate that reconditioning of a device can utilize a variety of techniques for disassembly, cleaning/replacement, and reassembly. Use of such techniques, and the resulting reconditioned device, are all within the scope of the present application.

[0189] In some embodiments, devices described herein can be processed before surgery. First, a new or used instrument is obtained and if necessary cleaned. The instrument can then be sterilized. In one sterilization technique, the instrument is placed in a closed and sealed container, such as a plastic or TYVEK bag. The container and instrument are then placed in a field of radiation that can penetrate the container, such as gamma radiation, x-rays, or high-energy electrons. The radiation kills bacteria on the instrument and in the container. The sterilized instrument can then be stored in the sterile container. The sealed container keeps the instrument sterile until it is opened in the medical facility.

[0190] One skilled in the art will appreciate further features and advantages of the invention based on the above-described embodiments. Accordingly, the invention is not to be limited by what has been particularly shown and described, except as indicated by the appended claims. All publications and references cited herein are expressly incorporated herein by reference in their entirety.

What is claimed is:

1. A meal detection system, comprising:
 - a plurality of sensors, each configured to sense a different physiological parameter of a user, the plurality of sensors being disposed external to the user; and
 - a processor in communication with the plurality of sensors and configured to analyze outputs of the plurality of sensors to detect meal intake by the user, the processor being further configured to trigger a controlled device to deliver a therapy to the user in response to meal intake detected by the processor.
2. The system of claim 1, wherein the plurality of sensors are of different types.
3. The system of claim 1, wherein, for each of the plurality of sensors, the processor is configured to calculate an index based on the output of the sensor and to determine that meal intake occurred when the index exceeds a threshold value.
4. The system of claim 3, wherein the processor is configured to calculate the threshold value by processing a set of training data using an average harmonic mean algorithm, the training data including sensor data for at least one user and ground truth data for the at least one user.
5. The system of claim 3, wherein the plurality of sensors includes an electromyograph configured to detect electrical activity of a muscle of the user and wherein the processor is configured to calculate an electromyograph index based on a number of peaks detected in the electromyograph output.
6. The system of claim 3, wherein the plurality of sensors includes a microphone configured to detect sounds emitted by the user and wherein the processor is configured to calculate a microphone index based on frequency matching and temporal matching of the microphone output to a predetermined pattern.
7. The system of claim 3, wherein the plurality of sensors includes an electrocardiograph configured to detect electrical activity of a heart of the user and wherein the processor is configured to calculate an electrocardiograph index based on a moving average filtered first derivative of the standard deviation of interbeat intervals in the electrocardiograph output.
8. The system of claim 3, wherein the plurality of sensors includes a temperature sensor configured to detect a temperature of the user and wherein the processor is configured to calculate a temperature sensor index based on a ratio of low frequency components of the first derivative of the temperature sensor output to low frequency components of the standard deviation of the temperature sensor output.
9. The system of claim 3, wherein the plurality of sensors includes an accelerometer configured to detect motion of the user and wherein the processor is configured to calculate an accelerometer index based on the total energy of the accelerometer output in a frequency band of interest.
10. The system of claim 3, wherein the plurality of sensors includes an electrogastragraph configured to detect electrical activity of a digestive system of the user and wherein the processor is configured to calculate an electrogastragraph index based on the total energy of the electrogastragraph output in a frequency band of interest.
11. The system of claim 3, wherein the plurality of sensors includes an impedance sensor configured to detect an impedance across a portion of the user and wherein the processor is configured to calculate an impedance sensor index based on the median energy of the impedance sensor output in a frequency band of interest.
12. The system of claim 1, wherein the plurality of sensors includes an electromyograph and an accelerometer, and wherein the processor is configured to calculate an electromyograph index, an electromyograph threshold value, an accelerometer index, and an accelerometer threshold value, and to determine that:
 - solid meal intake occurred when the electromyograph index exceeds the electromyograph threshold value;
 - liquid meal intake occurred when the electromyograph index does not exceed the electromyograph threshold value and the accelerometer index exceeds the accelerometer threshold value; and
 - no meal intake occurred when the electromyograph index does not exceed the electromyograph threshold value and the accelerometer index does not exceed the accelerometer threshold value.
13. The system of claim 1, wherein the plurality of sensors includes an impedance sensor and an accelerometer, and wherein the processor is configured to calculate an impedance sensor index, an impedance sensor threshold value, an accelerometer index, and an accelerometer threshold value, and to determine that:
 - solid meal intake occurred when the impedance sensor index exceeds the impedance sensor threshold value;
 - liquid meal intake occurred when the impedance sensor index does not exceed the impedance sensor threshold value and the accelerometer index exceeds the accelerometer threshold value; and
 - no meal intake occurred when the impedance sensor index does not exceed the impedance sensor threshold value and the accelerometer index does not exceed the accelerometer threshold value.
14. The system of claim 1, wherein the plurality of sensors includes an electromyograph and a microphone, and wherein the processor is configured to calculate an electromyograph index, an electromyograph threshold value, a microphone index, and a microphone threshold value, and to determine that:
 - solid meal intake occurred when the electromyograph index exceeds the electromyograph threshold value;
 - liquid meal intake occurred when the electromyograph index does not exceed the electromyograph threshold value and the microphone index exceeds the microphone threshold value; and
 - no meal intake occurred when the electromyograph index does not exceed the electromyograph threshold value and the microphone index does not exceed the microphone threshold value.
15. The system of claim 1, wherein the plurality of sensors includes an impedance sensor and a microphone, and wherein the processor is configured to calculate an impedance sensor index, an impedance sensor threshold value, a microphone index, and a microphone threshold value, and to determine that:
 - solid meal intake occurred when the impedance sensor index exceeds the impedance sensor threshold value and the microphone index exceeds the microphone threshold value;
 - liquid meal intake occurred when the impedance sensor index does not exceed the impedance sensor threshold value and the microphone index exceeds the microphone threshold value; and

no meal intake occurred when the impedance sensor index does not exceed the impedance sensor threshold value and the microphone index does not exceed the microphone threshold value.

16. The system of claim **1**, further comprising a controlled device, the controlled device being configured to at least one of:

- electrically stimulate tissue of the user;
- deliver a therapeutic agent to the user;
- deliver a therapeutic agent configured to provoke a release of one or more hormones from L-cells of the user to trigger ileal brake in the user;
- deliver insulin to the user;
- modulate bile acid levels in the user;
- modulate gastric pH levels in the user;
- induce an aversive response in the user;
- stimulate release of GLP-1 in the user;
- activate brown adipose tissue in the user;
- adjust a gastric band implanted in the user;
- control tonal contractions of the user's stomach;
- adjust a size or volume of a gastric space occupying device implanted in the user;
- modulate gastric emptying in the user;
- record a history of the user's meal intake events; and
- issue an alert to the user or to a caregiver of the user when the user's meal intake exceeds a predetermined threshold or deviates from a predetermined pattern.

17. A medical method, comprising:

- sensing a plurality of physiological parameters of a user using a plurality of sensors disposed externally to the user;
- using a processor in communication with the plurality of sensors, analyzing outputs of the plurality of sensors to detect meal intake by the user; and
- automatically triggering a controlled device to deliver a therapy to the user in response to meal intake detected by the processor.

18. The method of claim **17**, further comprising, for each of the plurality of sensors, using the processor to calculate an index based on the output of the sensor and using the processor to determine that meal intake occurred when the index exceeds a threshold value.

19. The method of claim **18**, further comprising using the processor to calculate the threshold value by processing a set of training data using an average harmonic mean algorithm, the training data including sensor data for at least one user and ground truth data for the at least one user.

20. The method of claim **18**, wherein said sensing and said analyzing include at least one of:

- detecting electrical activity of a muscle of the user using an electromyograph and calculating an electromyograph index based on a number of peaks detected in the electromyograph output;
- detecting sounds emitted by the user using a microphone and calculating a microphone index based on frequency matching and temporal matching of the microphone output to a predetermined pattern;
- detecting electrical activity of a heart of the user using an electrocardiograph and calculating an electrocardiograph index based on a moving average filtered first derivative of the standard deviation of interbeat intervals in the electrocardiograph output;
- detecting a temperature of the user and calculating a temperature sensor index based on a ratio of low frequency

- components of the first derivative of the temperature sensor output to low frequency components of the standard deviation of the temperature sensor output;

- detecting motion of the user using an accelerometer and calculating an accelerometer index based on the total energy of the accelerometer output in a frequency band of interest;

- detecting electrical activity of a digestive system of the user using an electrogastrograph and calculating an electrogastrograph index based on the total energy of the electrogastrograph output in a frequency band of interest; and

- detecting an impedance across a portion of the user using an impedance sensor and calculating an impedance sensor index based on the median energy of the impedance sensor output in a frequency band of interest.

21. The method of claim **17**, wherein triggering the controlled device comprises causing the controlled device to at least one of:

- electrically stimulate tissue of the user;
- deliver a therapeutic agent to the user;
- deliver a therapeutic agent configured to provoke a release of one or more hormones from L-cells of the user to trigger ileal brake in the user;
- deliver insulin to the user;
- modulate bile acid levels in the user;
- modulate gastric pH levels in the user;
- induce an aversive response in the user;
- stimulate release of GLP-1 in the user;
- activate brown adipose tissue in the user;
- adjust a gastric band implanted in the user;
- control tonal contractions of the user's stomach;
- adjust a size or volume of a gastric space occupying device implanted in the user;
- modulate gastric emptying in the user;
- record a history of the user's meal intake events; and
- issue an alert to the user or to a caregiver of the user when the user's meal intake exceeds a predetermined threshold or deviates from a predetermined pattern.

22. The method of claim **17**, wherein said sensing comprises detecting an impedance across a portion of the user using an impedance sensor having a first current electrode, a second current electrode, a first voltage electrode, and a second voltage electrode, and wherein the method further comprises at least one of:

- positioning the first current electrode on the user's left trapezius muscle, positioning the second current electrode on the user's right trapezius muscle, positioning the first voltage electrode on the user's chest below the user's left clavicle and about half way between the user's neck and the user's left shoulder, and positioning the second voltage electrode on the user's chest below the user's right clavicle and about half way between the user's neck and the user's right shoulder; and

- positioning the first current electrode on the user's chest below the user's left clavicle and about half way between the user's neck and the user's left shoulder, positioning the second current electrode on the user's chest below the user's right clavicle and about half way between the user's neck and the user's right shoulder, positioning the first voltage electrode beneath the first current electrode and inward towards the user's sternum,

and positioning the second voltage electrode beneath second current electrode and inward towards the user's sternum.

* * * * *

专利名称(译)	膳食检测装置和方法		
公开(公告)号	US20140275748A1	公开(公告)日	2014-09-18
申请号	US13/802089	申请日	2013-03-13
[标]申请(专利权)人(译)	伊西康内外科公司		
申请(专利权)人(译)	爱惜康内镜外科INC.		
当前申请(专利权)人(译)	爱惜康内镜外科INC.		
[标]发明人	DUNKI JACOBS ADAM HARRIS JASON L LEMAY MATHIEU PFLEIDERER MARTIN PROENCA MARTIN UTARD THIERRY		
发明人	DUNKI-JACOBS, ADAM HARRIS, JASON L. LEMAY, MATHIEU PFLEIDERER, MARTIN PROENÇA, MARTIN UTARD, THIERRY		
IPC分类号	A61B5/00 A61F5/00		
CPC分类号	A61B5/4839 A61F2005/002 A61B5/01 A61B5/0402 A61B5/0488 A61B5/04884 A61B5/0537 A61B5/1107 A61B5/4238 A61B5/4836 A61B5/4866 A61N1/36007 A61B2505/07 A61F5/0013 A61B7/008 A61F5/0059 A61M5/1723		
优先权	61/780013 2013-03-13 US		
其他公开文献	US9168000		
外部链接	Espacenet USPTO		

摘要(译)

本文公开了用于检测膳食摄入的装置和方法。在一些实施例中，一个或多个传感器可用于检测或监测用户的生理参数（例如，心率，身体运动，温度，pH，阻抗，胃伸展，声音发射等）。传感器的输出可以由计算机系统接收，该计算机系统被配置为分析传感器数据并确定膳食摄入是否已经发生或正在发生。计算机系统的确定可用于触发，调制或以其他方式控制一个或多个治疗设备。还可以使用该确定来控制其他类型的设备，例如监视或记录设备。

