

Figure 1

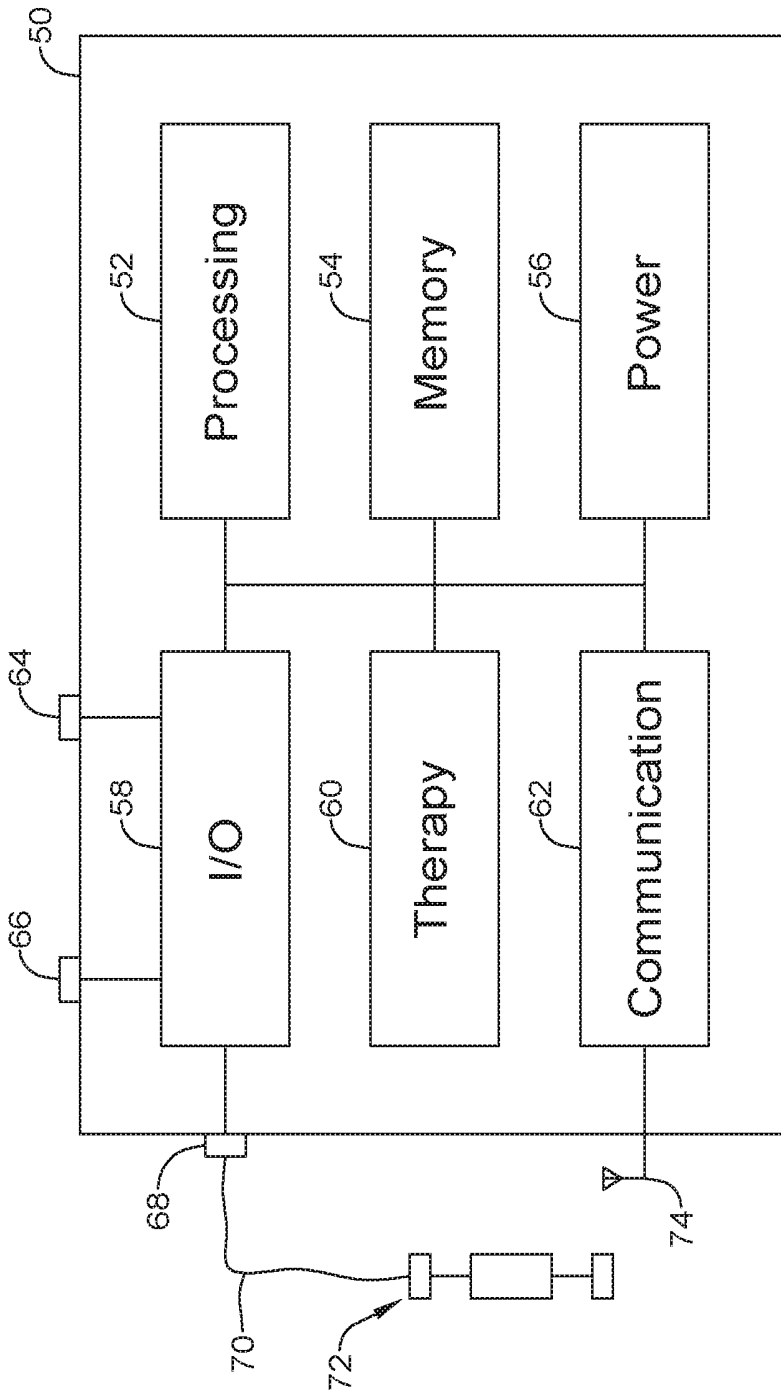

Figure 2

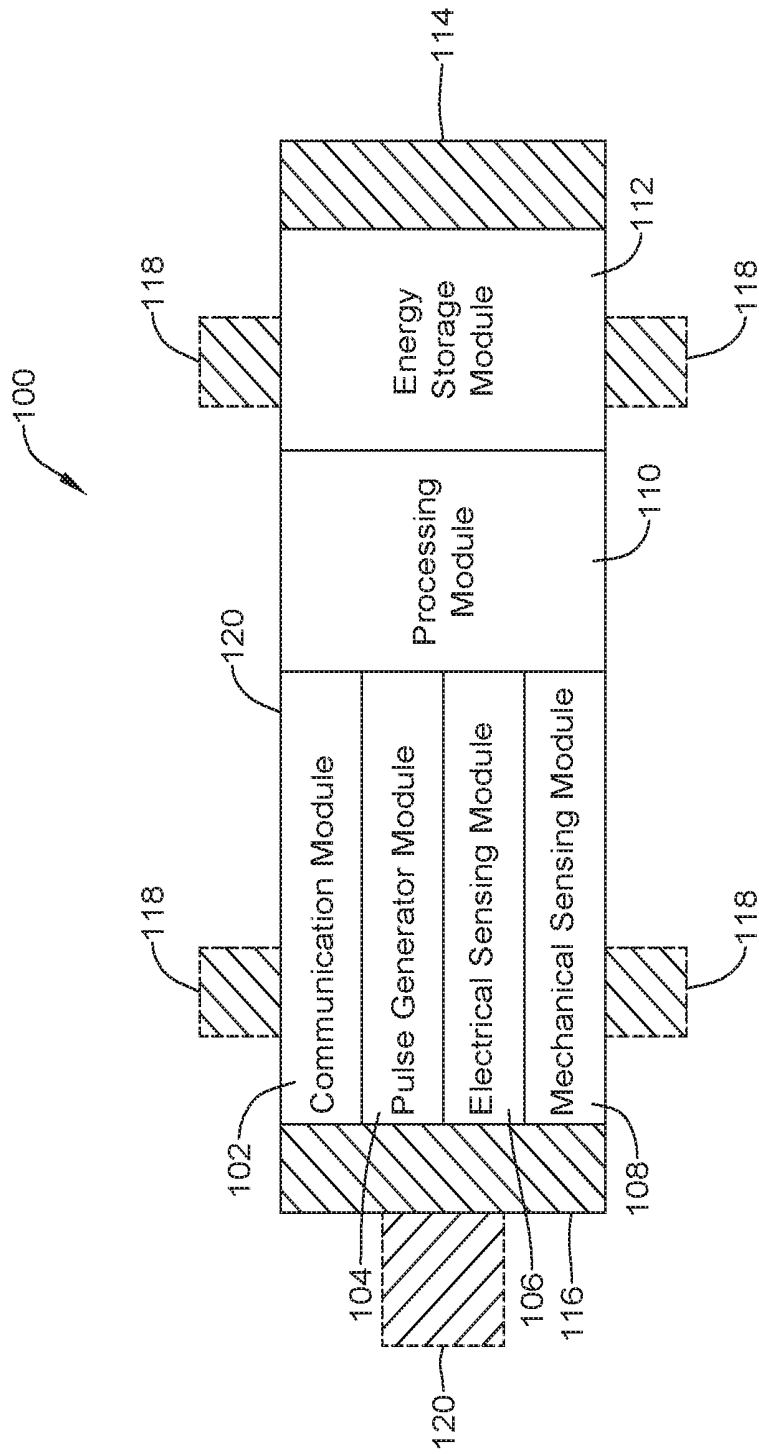

Figure 3

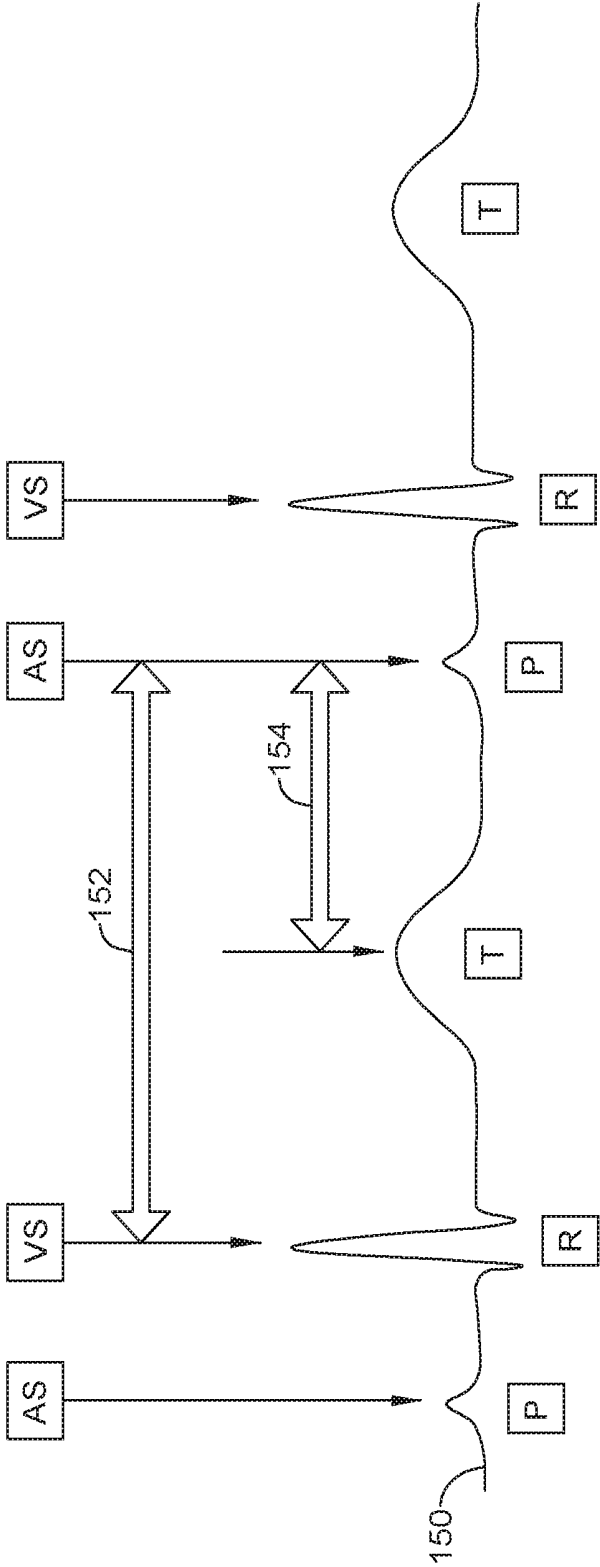

Figure 4

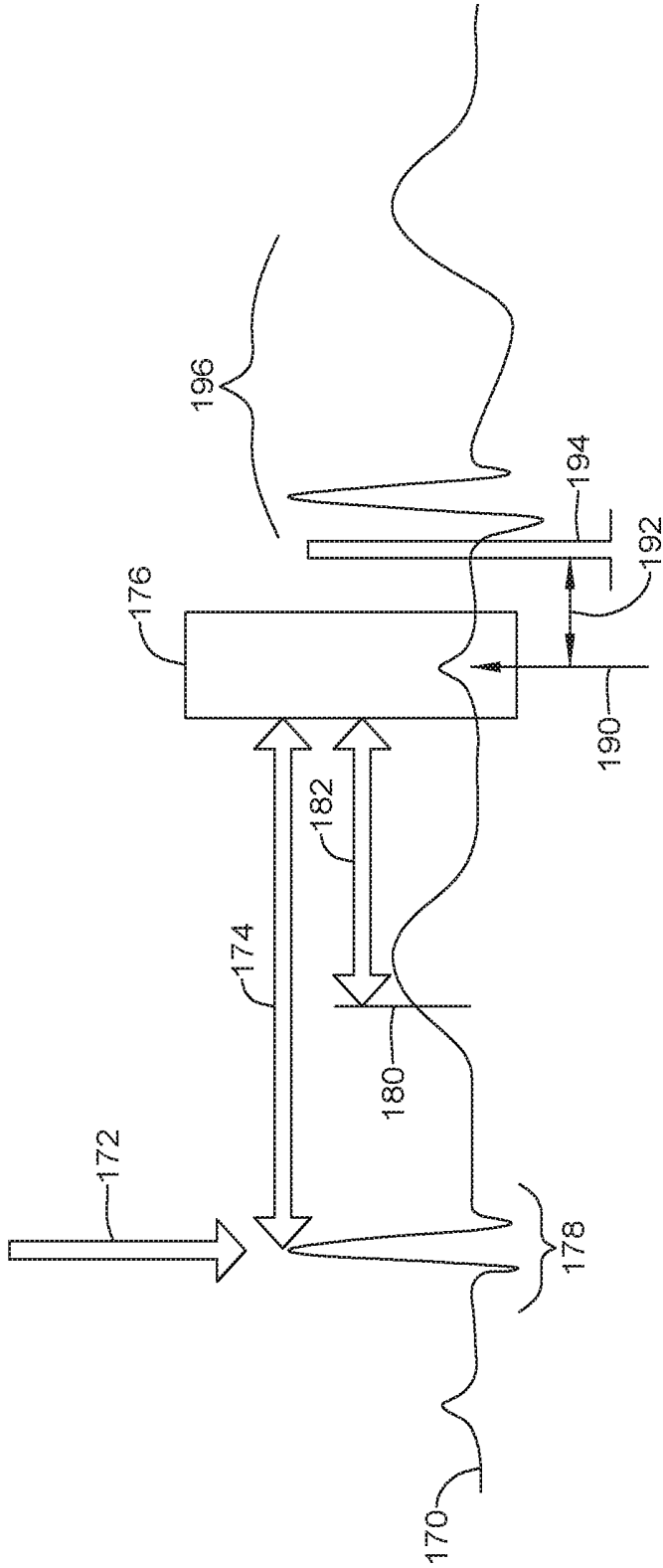

Figure 5A

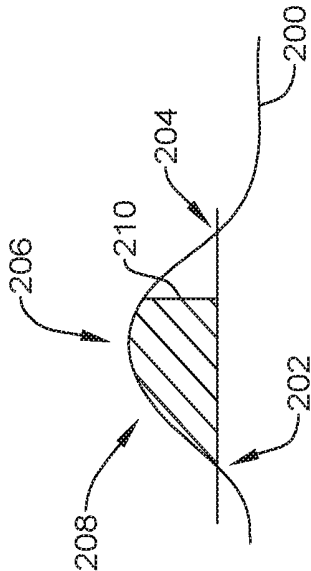

Figure 5B

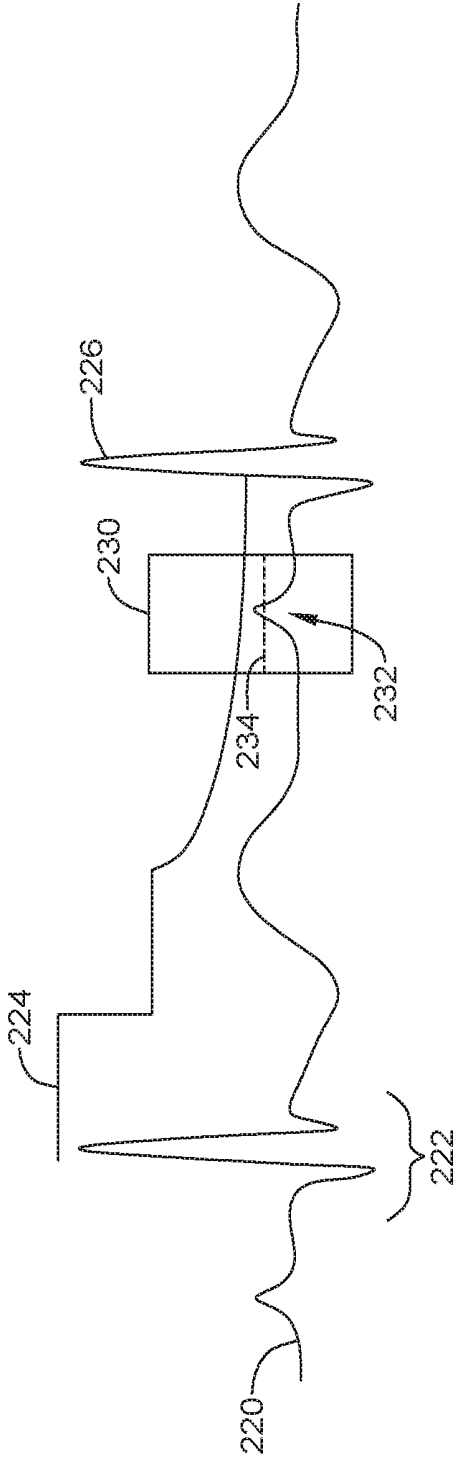

Figure 5C

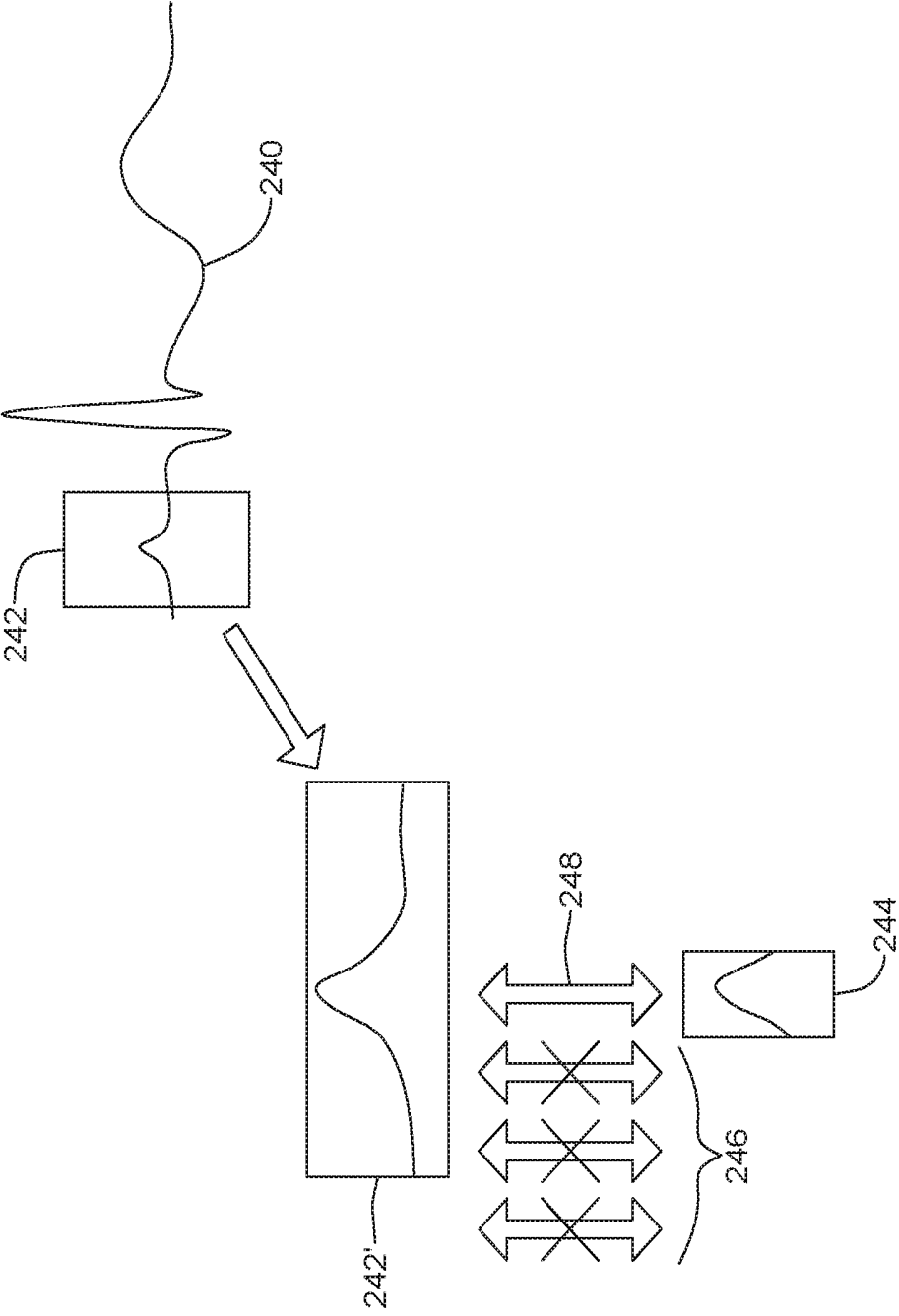

Figure 5D

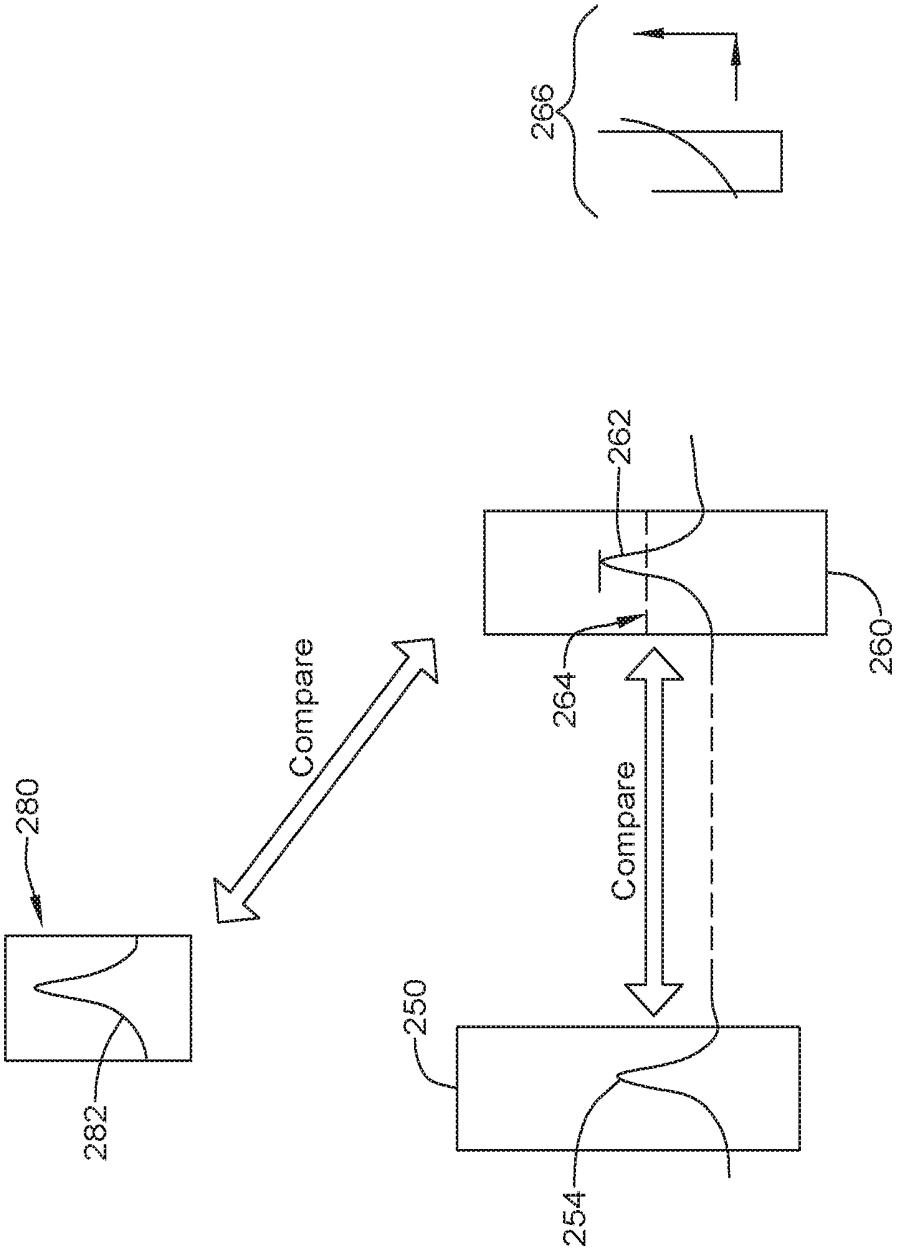

Figure 6

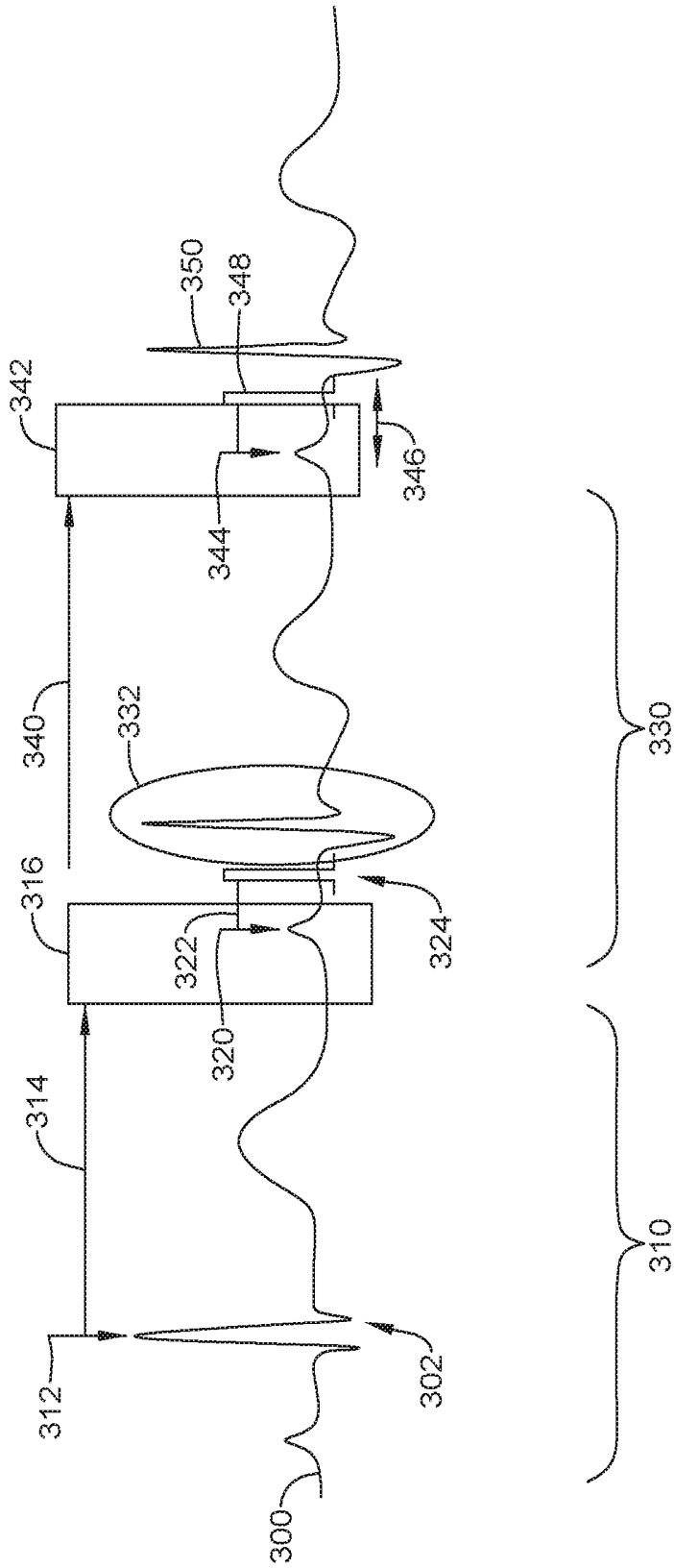

Figure 7

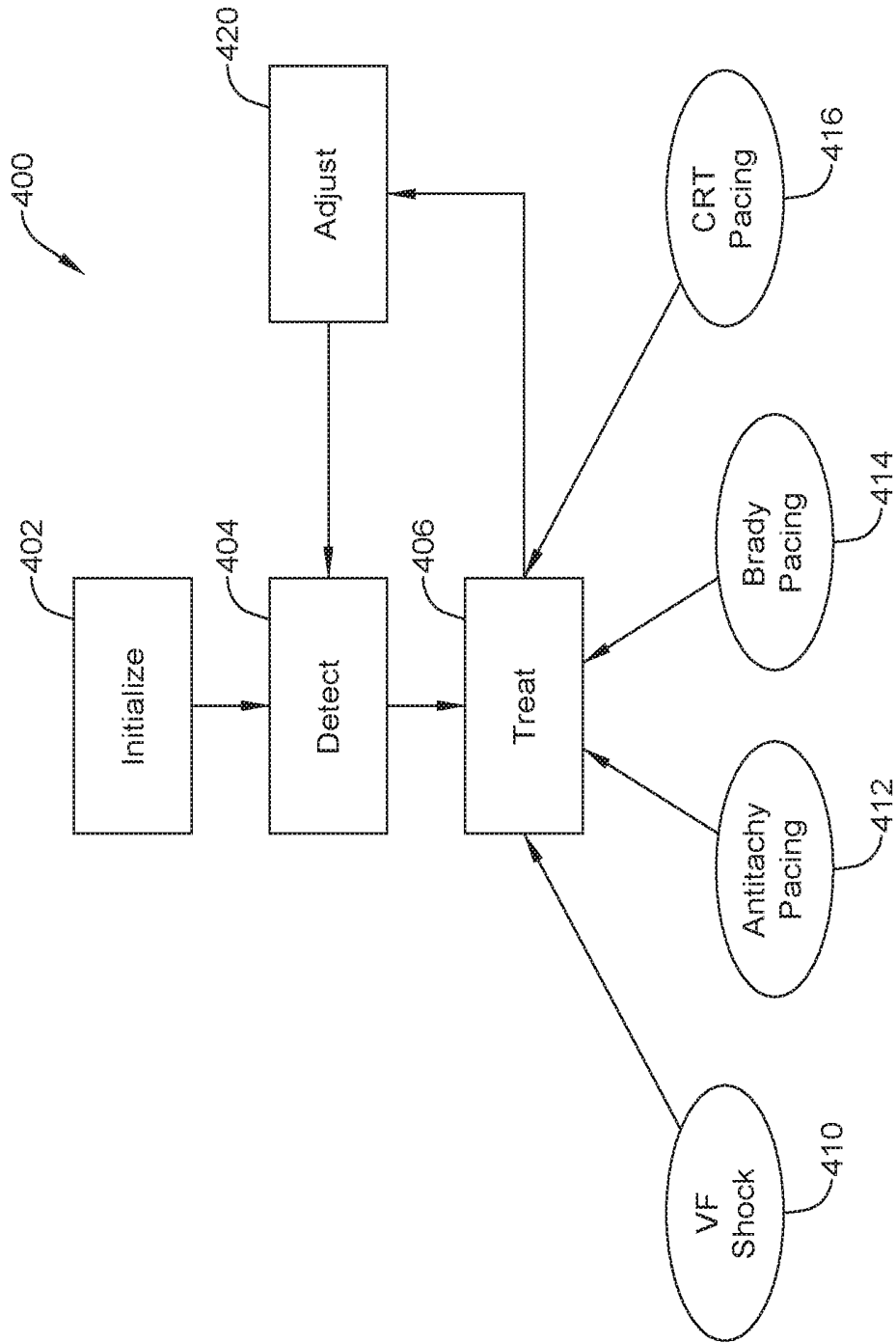

Figure 8

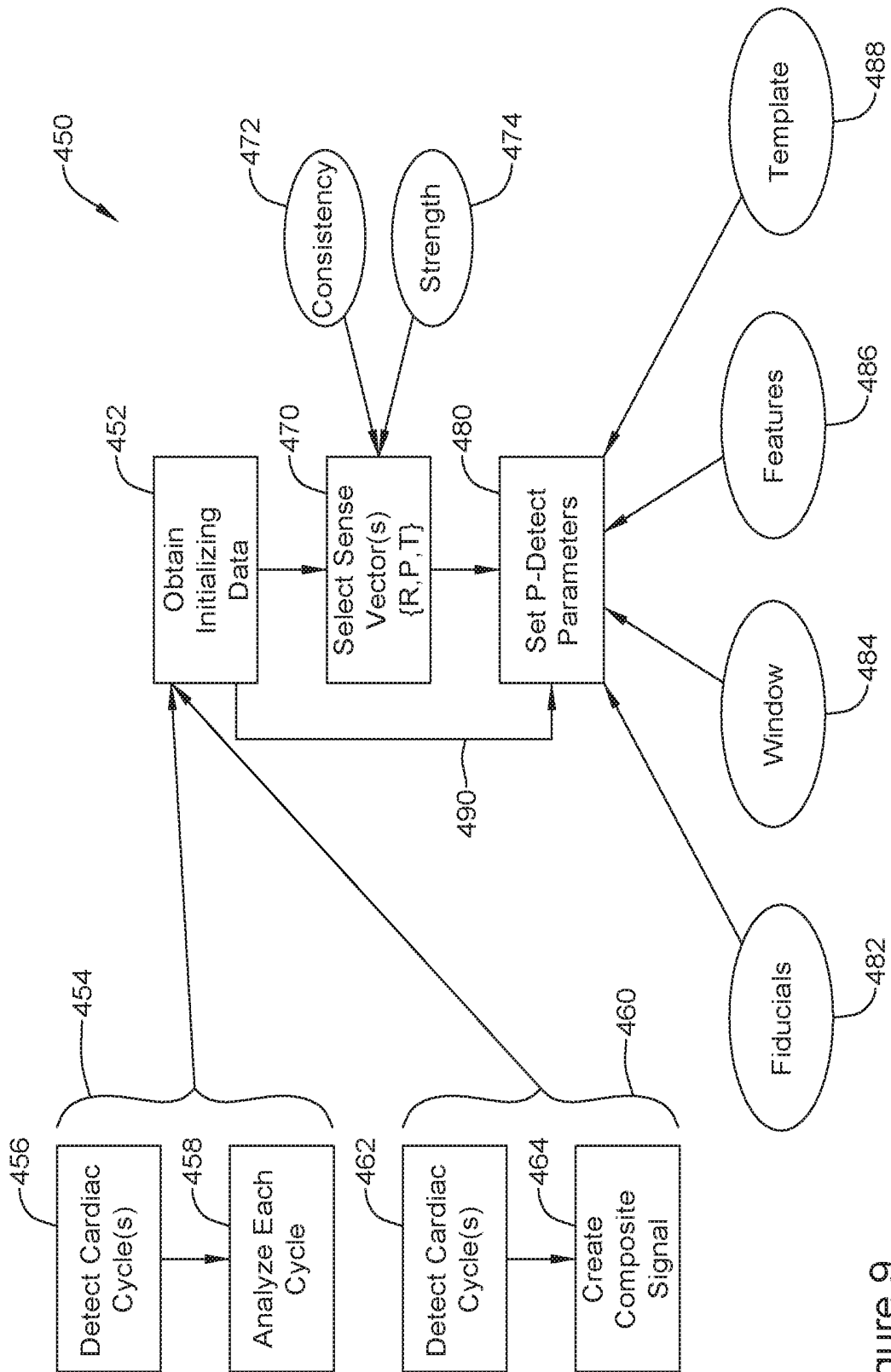

Figure 9

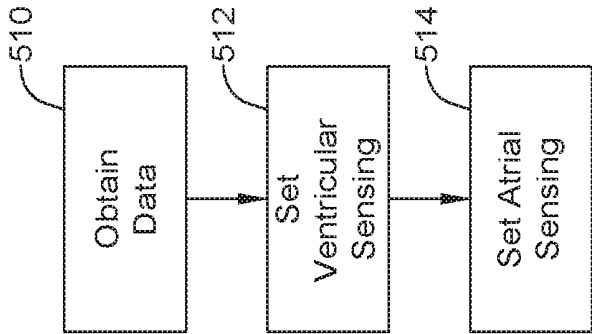

Figure 10B

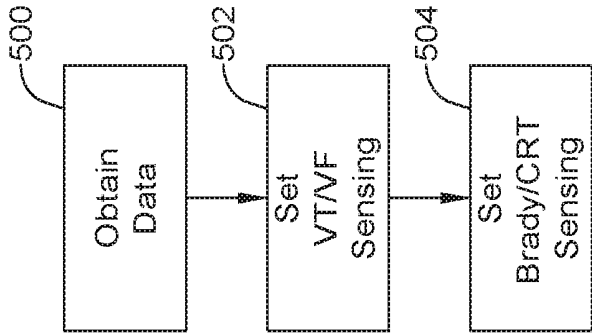

Figure 10A

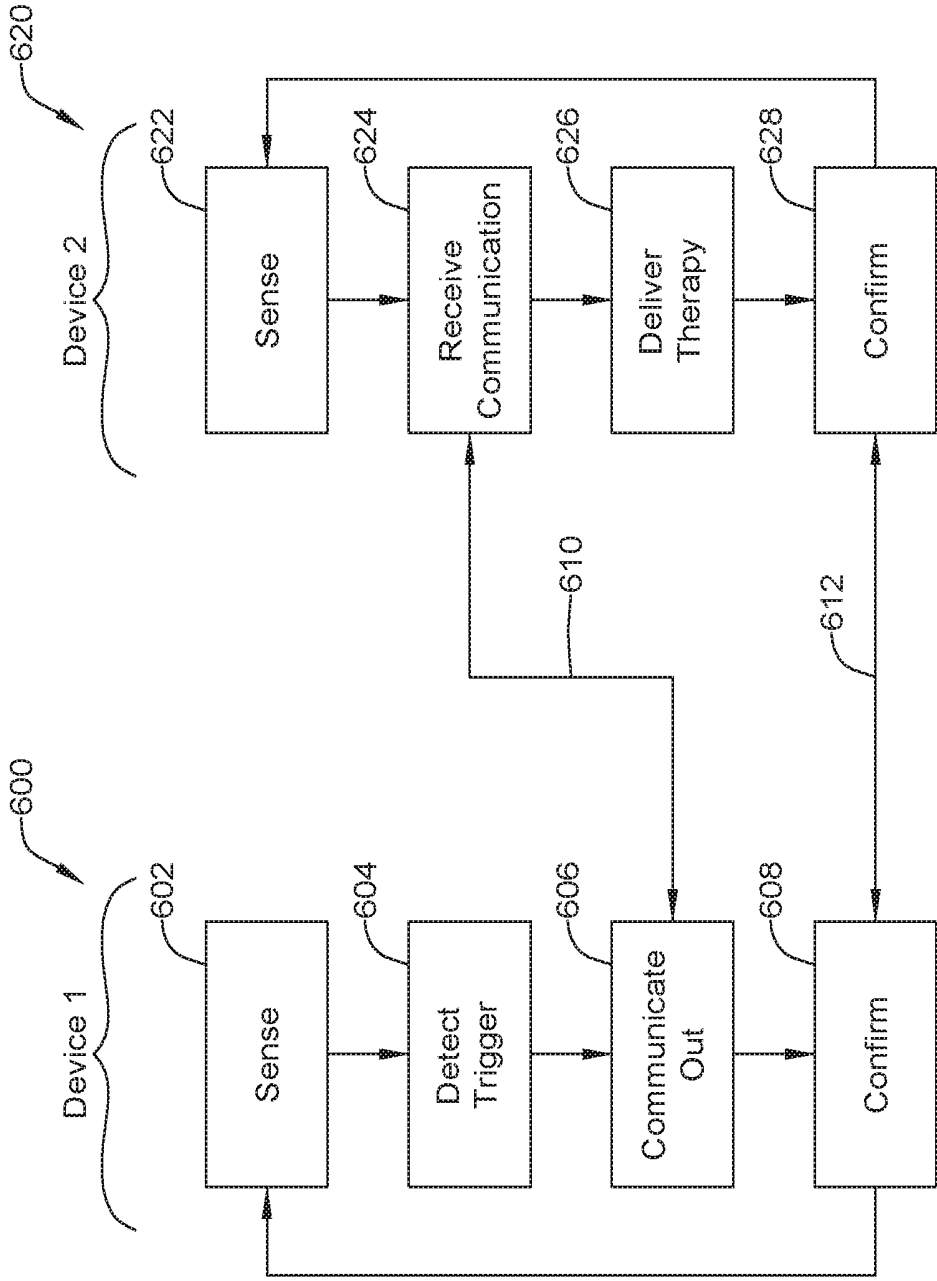

Figure 11

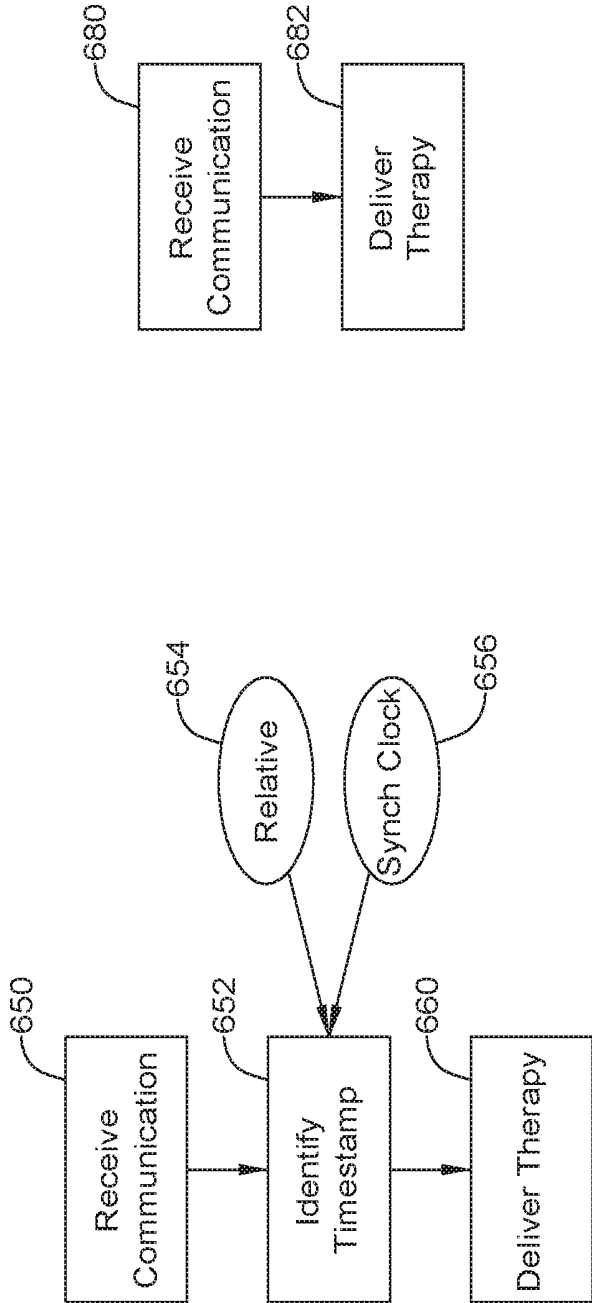

Figure 12A

Figure 12B

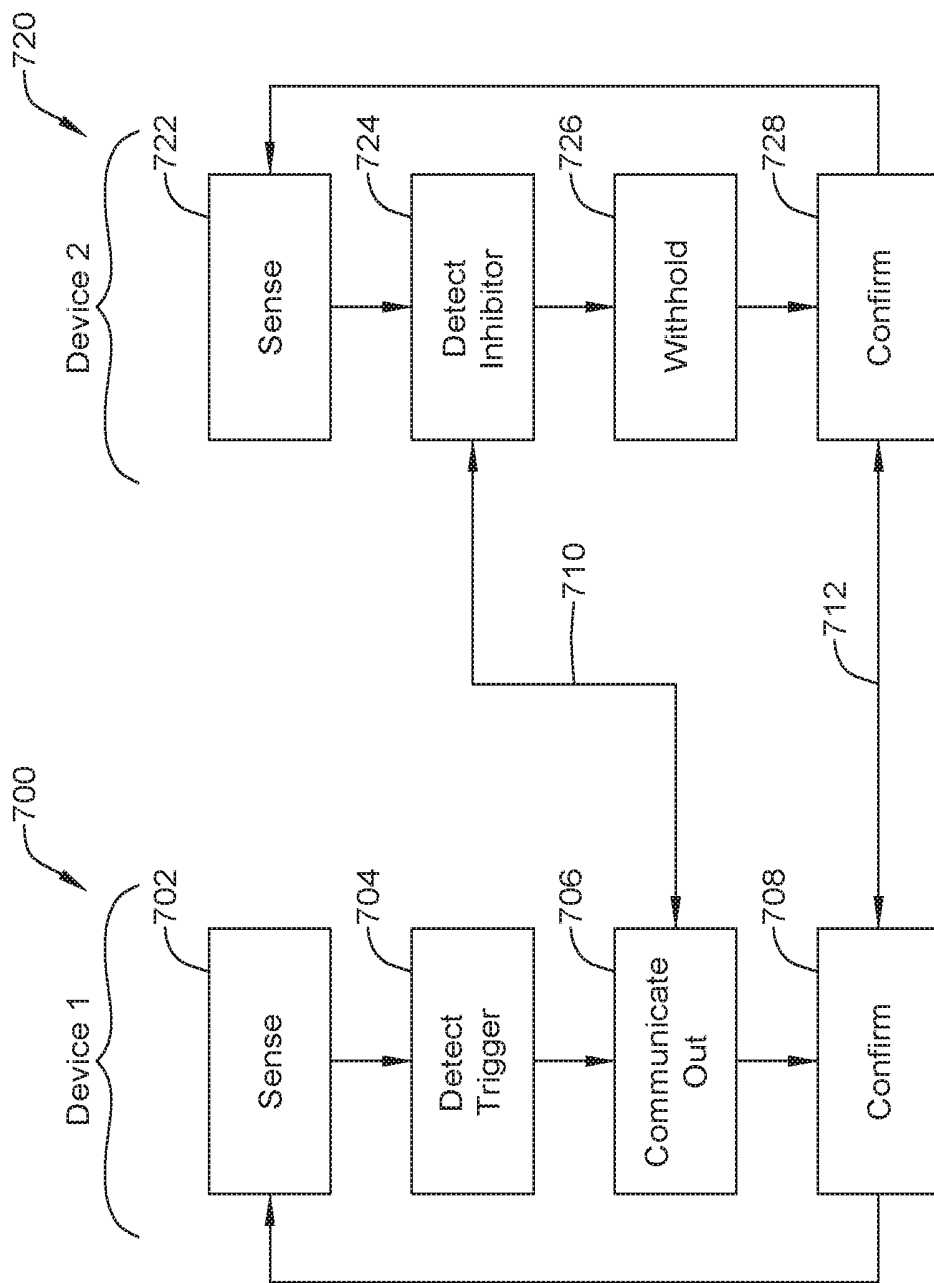

Figure 13

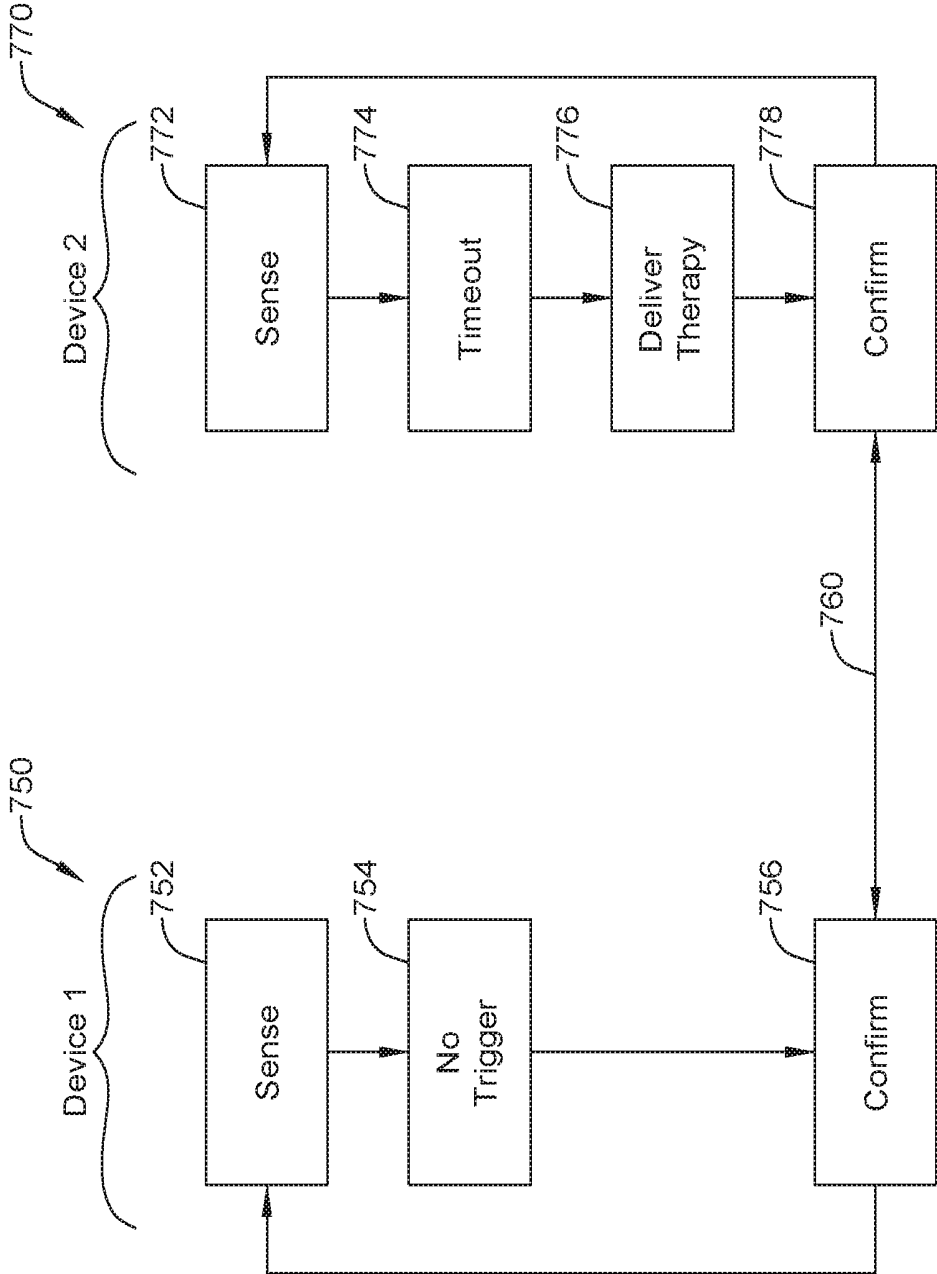

Figure 14

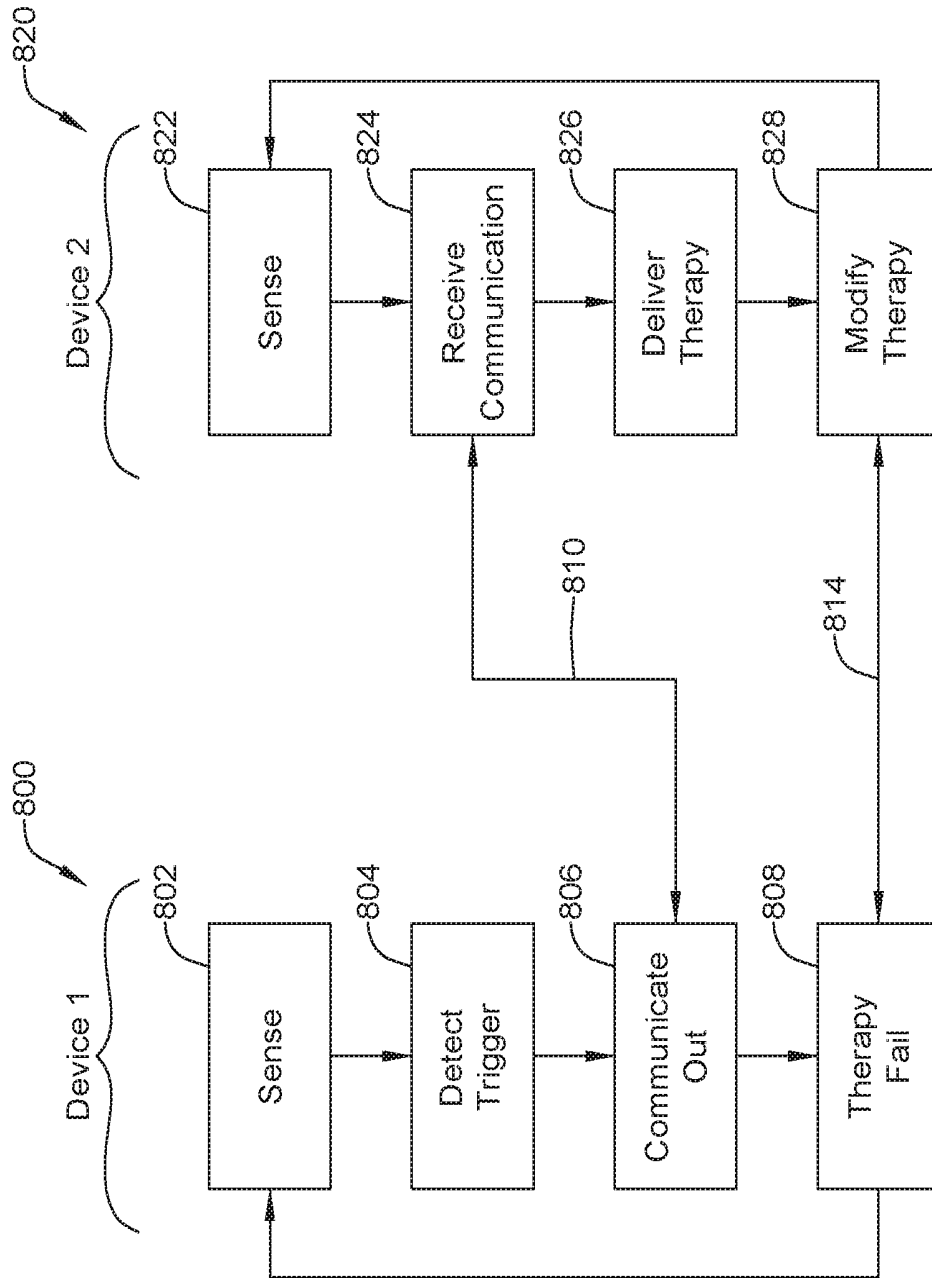

Figure 15



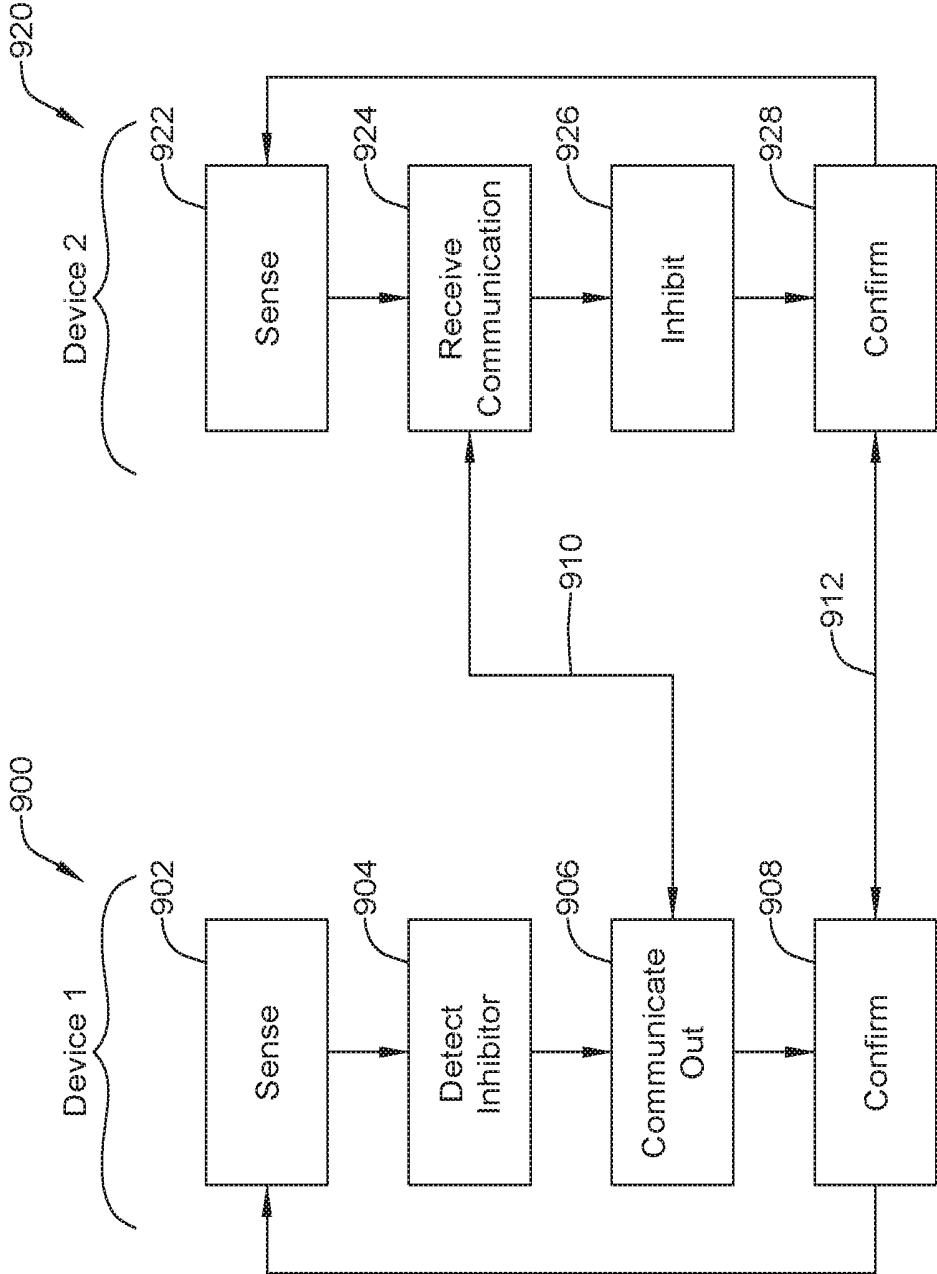

Figure 17

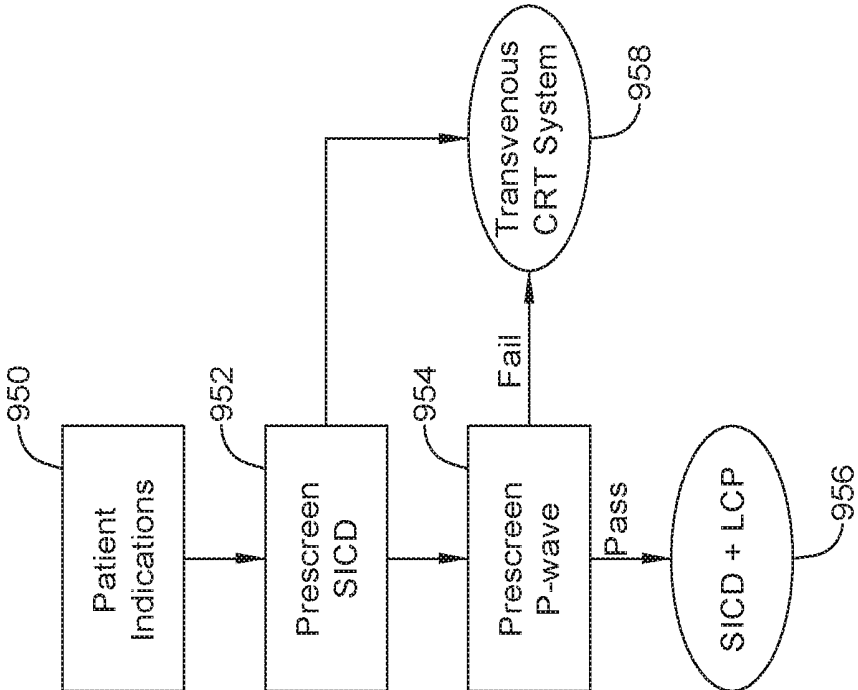

Figure 18

**CARDIAC THERAPY SYSTEM USING  
SUBCUTANEOUSLY SENSED P-WAVES FOR  
RESYNCHRONIZATION PACING  
MANAGEMENT**

CROSS REFERENCE TO RELATED  
APPLICATIONS

[0001] The present application is a continuation of U.S. patent application Ser. No. 15/633,517, filed Jun. 26, 2017 and titled CARDIAC THERAPY SYSTEM USING SUBCUTANEOUSLY SENSED P-WAVES FOR RESYNCHRONIZATION PACING MANAGEMENT, which claims the benefit of and priority to U.S. Provisional Patent Application Ser. No. 62/355,121, filed Jun. 27, 2016, the disclosures of which are incorporated herein by reference.

BACKGROUND

[0002] Cardiac resynchronization therapy (CRT) resynchronizes the electrical activation and therefore the contractions of the heart's chambers to enhance pumping efficiency. Benefits may include increased exercise capacity and reduced hospitalization and mortality. CRT devices operate by controlling or affecting the timing of contraction of one or more cardiac chambers relative to one or more other cardiac chambers. For example, contractions of one or more of the ventricle(s) may be timed relative to contraction of the atria, or contractions of the left and right ventricles may be timed relative to one another.

[0003] A "fusion" beat occurs when multiple activation signals affect the same tissue at the same time. For example, electrical fusion between pacing of one ventricle with spontaneous activation of another ventricle (for example, paced left ventricular activation and spontaneous right ventricular activation) produces a fusion beat. The generation of fusion beats is a goal of cardiac resynchronization in many circumstances.

[0004] Prior systems generally included intracardiac electrodes coupled via transvenous leads to an implanted pulse generator. The leads of such systems are widely known as introducing various morbidities and are prone to eventual conductor and/or insulator failure. The presence of leads and their known morbidities and failures in CRT systems likely reduce usage within the indicated population of heart failure patients.

[0005] Newer generation pacemakers include the leadless cardiac pacemaker (LCP), which can be implanted entirely within the heart and does not require a transvenous (or any) lead. Such devices are commercially available in certain places, but are currently indicated for use in bradycardia pacing. The LCP also presents an opportunity to provide an alternative to traditional CRT therapy using transvenous leads. New and alternative systems, devices and methods directed at providing CRT therapy using the LCP are desired.

OVERVIEW

[0006] The present inventors have recognized, among other things, that a problem to be solved is the management of CRT using information gathered by plural implantable devices. In order to resynchronize behavior of the chambers of the heart that are poorly synchronized, it is necessary to understand what is occurring, and when, in different chambers. An LCP implanted in a single chamber of the heart

may, in some examples, receive data transmitted from a separate device, such as another LCP or an extracardiac device such as a subcutaneous cardiac monitor, or a subcutaneous implantable cardiac defibrillator (SICD), and use the received data to time the delivery of a pacing pulse to a heart chamber. In an embodiment, the LCP receives an indication from an SICD that a P-wave, indicating atrial depolarization (which occurs relative to atrial contraction), has been detected by the SICD at a particular time, and the LCP responds to the communicated information and delivers a pacing pulse.

[0007] In another example, an LCP may receive a command to pace in response to analysis performed by a second device. In a specific example, an SICD may detect a P-wave, determine timing and/or other parameters relative to the P-wave, and the SICD may then command therapy by the LCP. In another example, an LCP may deliver pacing pulses according to a self-determining timing sequence, but may occasionally or periodically receive supplemental timing information from a second device such as an SICD. For example, an SICD may determine evoked response characteristics to ensure fusion beats are resulting; if no fusion is observed, the SICD may issue a communication to the LCP. In this example, the SICD or the LCP may determine corrective steps to take by adjusting timing or energy, or other characteristic of the delivered therapy.

[0008] In further examples, a patient may receive Brady-cardia pacing by having an SICD detect a P-wave and communicate to an LCP. For example, a patient having an atrioventricular nodal block (AV block) may exhibit P-waves that do not conduct naturally to the ventricles, and the LCP located, for example, in the right ventricle, may respond to data communicated to it to deliver pacing pulses. The communication may occur with every beat or may be periodic or occasional to confirm operation and/or prompt timing enhancements

[0009] A first non-limiting example takes the form of an implantable device system comprising: a first medical device configured to deliver a pacing therapy to the heart of a patient; and a second medical device configured to sense activity of the heart of the patient; wherein the first medical device is configured to receive communication from the second medical device; wherein the second medical device is configured to detect an atrial event in the heart of the patient and issue a communication to the first medical device; wherein the first medical device is configured to deliver therapy to the heart of the patient in response to the communication issued by the second medical device.

[0010] Additionally or alternatively, a second non-limiting example takes the form of a system as in the first non-limiting example, wherein the second medical device is configured for an initialization sequence for detecting the atrial event, the initialization sequence comprising: detecting at least first and second cardiac cycles of the patient; establishing a window for detection of the atrial event; wherein the second medical device is configured to observe cardiac signals of the patient during the window for detection of the atrial event in order to detect the atrial event.

[0011] Additionally or alternatively, a third non-limiting example takes the form of a system as in the second non-limiting example, wherein the second medical device is configured to establish the window for detection of the atrial event relative to a feature of a ventricular event.

**[0012]** Additionally or alternatively, a fourth non-limiting example takes the form of a system as in the second non-limiting example, wherein the second medical device is configured to detect or determine occurrence of a therapy output by the first medical device, and to establish the window for detection of the atrial event relative to a therapy output by the first medical device.

**[0013]** Additionally or alternatively, a fifth non-limiting example takes the form of a system as in the second non-limiting example, wherein the second medical device is configured to calculate a composite cardiac cycle data set using the at least first and second cardiac cycles, and to establish the window for detection of the atrial event using the composite cardiac cycle data set.

**[0014]** Additionally or alternatively, a sixth non-limiting example takes the form of a system as in the second non-limiting example, wherein the initialization sequence further comprises determining characteristics for the atrial event, further wherein the second medical device is configured to use the characteristics determined during the initialization sequence in order to detect the atrial event.

**[0015]** Additionally or alternatively, a seventh non-limiting example takes the form of a system as in the sixth non-limiting example, wherein the characteristics for the atrial event comprise at least one of: an amplitude; a relative amplitude as compared to one or more preceding ventricular events; a relative amplitude as compared to a mean amplitude during a cardiac cycle; or a maximum or minimum slope.

**[0016]** Additionally or alternatively, an eighth non-limiting example takes the form of a system as in the second non-limiting example, wherein the second medical device is configured to determine whether a signal captured during the window for detection of the atrial event matches a stored atrial event template or a dynamic atrial event template.

**[0017]** Additionally or alternatively, a ninth non-limiting example takes the form of a system as in the first non-limiting example, wherein the second medical device comprises a plurality of electrodes configured for use in sensing cardiac signals, and the second medical device is configured to perform a sensing vector selection routine in which: the second medical device analyzes signals from a plurality of sensing vectors defined by the plurality of electrodes and selects a first sensing configuration for detection of ventricular events; and the second medical device analyzes signals from a plurality of sensing vectors defined by the plurality of electrodes and selects a second sensing configuration for detection of atrial events.

**[0018]** Additionally or alternatively, a tenth non-limiting example takes the form of a system as in the ninth non-limiting example, wherein the second medical device is configured to determine an atrial sensing window for detection of atrial events and is configured to selectively use the second sensing configuration to determine whether an atrial event takes place in the atrial sensing window.

**[0019]** Additionally or alternatively, an eleventh non-limiting example takes the form of a system as in the ninth non-limiting example, wherein the second medical device is configured to determine one or more parameters for sensing of atrial events using the second sensing configuration.

**[0020]** Additionally or alternatively, a twelfth non-limiting example takes the form of a system as in the ninth non-limiting example, wherein the second medical device is configured to establish a template for atrial events to use to

determine whether a signal captured using the second sensing configuration is an atrial event of a predetermined type.

**[0021]** Additionally or alternatively, a thirteenth non-limiting example takes the form of a system as in any of the first to twelfth non-limiting examples, wherein the therapy is configured to treat bradycardia.

**[0022]** Additionally or alternatively, a fourteenth non-limiting example takes the form of a system as in any of the first to twelfth non-limiting examples, wherein the therapy is configured to improve cardiac synchronization and contraction efficacy.

**[0023]** Additionally or alternatively, a fifteenth non-limiting example takes the form of a system as in the fourteenth non-limiting example, wherein the communication is configured to indicate that the second medical device has detected the atrial event, and the first medical device is configured to determine when the therapy is to be delivered relative to timing of the atrial event.

**[0024]** Additionally or alternatively, a sixteenth non-limiting example takes the form of a system as in the fourteenth non-limiting example, wherein the communication is configured to command delivery of the therapy by the first device at a particular time.

**[0025]** Additionally or alternatively, a seventeenth non-limiting example takes the form of a system as in any of the first to sixteenth non-limiting examples, wherein the first medical device is a leadless cardiac pacemaker, and the second medical device is an implantable cardiac monitor.

**[0026]** Additionally or alternatively, an eighteenth non-limiting example takes the form of a system as in any of the first to sixteenth non-limiting examples, wherein the first medical device is a leadless cardiac pacemaker, and the second medical device is a subcutaneous implantable defibrillator.

**[0027]** Additional or alternatively, in a nineteenth non-limiting example, the present invention may take the form of methods for providing cardiac resynchronization therapy and/or bradycardia pacing therapy comprising using a system as in any of the first to eighteenth non-limiting examples.

**[0028]** A twentieth non-limiting example takes the form of an implantable medical device comprising: a plurality of implantable electrodes; operational circuitry for analyzing signals captured using the plurality of implantable electrodes; and communication circuitry for communicating to a second implantable medical device; wherein the operational circuitry is configured to perform a sensing vector selection routine in which: the operational circuitry analyzes signals from a plurality of sensing vectors defined by the plurality of electrodes and selects a first sensing configuration for detection of ventricular events; and the operational circuitry analyzes signals from a plurality of sensing vectors defined by the plurality of electrodes and selects a second sensing configuration for detection of atrial events; and further wherein: the operational circuitry is configured to use the second sensing configuration to determine whether an atrial event is detected; and in response to determining that an atrial event has been detected, the operational circuitry is configured to communicate to the second medical device.

**[0029]** Additionally or alternatively, a twenty-first non-limiting example takes the form of a system as in the twentieth non-limiting example, wherein the operational circuitry is configured to determine an atrial sensing window for detection of atrial events and is configured to selectively

use the second sensing configuration to determine whether an atrial event takes place in the atrial sensing window, wherein the operational circuitry is configured to define the atrial sensing window in relationship to a ventricular sensed event sensed using the first sensing configuration.

**[0030]** Additionally or alternatively, a twenty-second non-limiting example takes the form of a system as in the twentieth non-limiting example, wherein the operational circuitry is configured to determine an atrial sensing window for detection of atrial events and is configured to selectively use the second sensing configuration to determine whether an atrial event takes place in the atrial sensing window, wherein the operational circuitry is configured to define the atrial sensing window in relationship to a detected therapy output by the second medical device.

**[0031]** Additionally or alternatively, a twenty-third non-limiting example takes the form of a system as in the twentieth non-limiting example, wherein the operational circuitry is configured to determine one or more parameters for sensing of atrial events using the second sensing configuration.

**[0032]** Additionally or alternatively, a twenty-fourth non-limiting example takes the form of a system as in the twentieth non-limiting example, wherein the operational circuitry is configured to establish a template for atrial events to use to determine whether a signal captured using the second sensing configuration is an atrial event of a predetermined type.

**[0033]** A twenty-fifth non-limiting example takes the form of an implantable medical device comprising: a plurality of implantable electrodes; operational circuitry for analyzing signals captured using the plurality of implantable electrodes; and communication circuitry for communicating to a second implantable medical device; wherein the operational circuitry is configured to perform an initialization sequence for detecting the atrial event, the initialization sequence comprising: detecting at least first and second cardiac cycles of the patient; establishing a window for detection of the atrial event; wherein the operational circuitry is configured to observe cardiac signals of the patient during the window for detection of the atrial event in order to detect the atrial event.

**[0034]** Additionally or alternatively, a twenty-sixth non-limiting example takes the form of a system as in the twenty-fifth non-limiting example, wherein the operational circuitry is configured to establish the window for detection of the atrial event relative to a feature of a ventricular event.

**[0035]** Additionally or alternatively, a twenty-seventh non-limiting example takes the form of a system as in the twenty-fifth non-limiting example, wherein the operational circuitry is configured to detect or determine occurrence of a therapy output by the second medical device, and to establish the window for detection of the atrial event relative to a therapy output by the second medical device.

**[0036]** Additionally or alternatively, a twenty-eighth non-limiting example takes the form of a system as in the twenty-fifth non-limiting example, wherein the operational circuitry is configured to calculate a composite cardiac cycle data set using the at least first and second cardiac cycles, and to use the composite cardiac cycle data set to establish the window for detection of the atrial event.

**[0037]** Additionally or alternatively, a twenty-ninth non-limiting example takes the form of a system as in the twenty-fifth non-limiting example, wherein operational cir-

cuitry is configured such that the initialization sequence further comprises determining characteristics for the atrial event, further wherein the operational circuitry is configured to determine use the characteristics determined during the initialization sequence in order to detect the atrial event.

**[0038]** Additionally or alternatively, a thirtieth non-limiting example takes the form of a system as in the twenty-fifth non-limiting example, wherein the operational circuitry is configured such that the characteristics for the atrial event comprise at least one of: an amplitude; a relative amplitude as compared to one or more preceding ventricular events; a relative amplitude as compared to a mean amplitude during a cardiac cycle; or a maximum or minimum slope.

**[0039]** Additionally or alternatively, a thirty-first non-limiting example takes the form of a system as in the twenty-fifth non-limiting example, wherein the operational circuitry is configured to determine whether a signal captured during the window for detection of the atrial event matches a stored atrial event template or a dynamic atrial event template.

**[0040]** Additionally or alternatively, a thirty-second non-limiting example takes the form of an implantable medical device system as in any of the twentieth to thirty-first non-limiting examples, wherein the first medical device is a subcutaneous implantable cardiac monitor, and the second medical device is a leadless cardiac pacemaker.

**[0041]** Additionally or alternatively, a thirty-third non-limiting example takes the form of an implantable medical device system as in any of the twentieth to thirty-first non-limiting examples, wherein the first medical device is a subcutaneous implantable cardiac defibrillator, and the second medical device is a leadless cardiac pacemaker.

**[0042]** Additionally or alternatively, a thirty-fourth non-limiting example takes the form of a method of treating a patient comprising providing cardiac resynchronization therapy by using a system as in any of the twentieth to thirty-third non-limiting examples.

**[0043]** Additionally or alternatively, a thirty-fifth non-limiting example takes the form of a method of treating a patient comprising providing bradycardia pacing therapy by using a system as in any of the twentieth to thirty-third non-limiting examples.

**[0044]** This is intended to provide an overview of subject matter of the present patent application. It is not intended to provide an exclusive or exhaustive explanation of the invention. The detailed description is included to provide further information about the present patent application.

#### BRIEF DESCRIPTION OF THE DRAWINGS

**[0045]** In the drawings, which are not necessarily drawn to scale, like numerals may describe similar components in different views. Like numerals having different letter suffixes may represent different instances of similar components. The drawings illustrate generally, by way of example, but not by way of limitation, various embodiments discussed in the present document.

**[0046]** FIG. 1 illustrates a patient having a plurality of implantable medical devices;

**[0047]** FIG. 2 illustrates a block diagram of an implantable medical device;

**[0048]** FIG. 3 shows an illustrative implantable leadless cardiac pacemaker;

**[0049]** FIG. 4 shows an illustrative cardiac signal;

[0050] FIG. 5A shows another illustrative cardiac signal, this time with indications of a pacing therapy being delivered;

[0051] FIG. 5B shows example timing fiducials for a signal;

[0052] FIGS. 5C-5D illustrate methods of detecting a P-wave;

[0053] FIG. 6 illustrates ways that a signal feature may be analyzed;

[0054] FIG. 7 shows another cardiac signal to illustrate operation of an embodiment;

[0055] FIGS. 8, 9, and 10A-10B show block diagrams for illustrative examples;

[0056] FIG. 11 shows in block flow form operation of cooperating devices;

[0057] FIGS. 12A-12B illustrate different manners of handling cross-device timing;

[0058] FIGS. 13-17 show in block flow form operations of cooperating devices; and

[0059] FIG. 18 shows a pre-implantation process flow.

#### DETAILED DESCRIPTION

[0060] The following description should be read with reference to the drawings. The description and the drawings, which are not necessarily to scale, depict illustrative embodiments and are not intended to limit the scope of the disclosure.

[0061] FIG. 1 illustrates a patient 10 with a first implanted medical device, shown as a leadless cardiac pacemaker (LCP) 14 implanted inside the heart 12, in the left ventricle for illustrative purposes. The LCP 14 may be implanted in other chambers, such as the right ventricle or in the atrium, and more than one LCP may be provided.

[0062] A second medical device in the form of a subcutaneous implantable defibrillator (SICD) 16 having a left axillary canister and a lead having a bifurcation to provide two fingers, at 18 and 20. The lead includes a plurality of electrodes such as button or ring electrodes at 20, 22, 24 and 26, and may also include one or more coil electrodes as shown at 28.

[0063] The illustration in FIG. 1 shows a bifurcation in the lead 18/20; in other embodiments a simpler lead may be provided having a single elongated member with a plurality of electrodes thereon such as shown, for example, in U.S. Pat. No. 9,079,035, titled ELECTRODE SPACING IN A SUBCUTANEOUS IMPLANTABLE CARDIAC STIMULUS DEVICE, the disclosure of which is incorporated herein by reference. Rather than bifurcation, plural leads may be provided as shown, for example, in U.S. Pat. No. 7,149,575, titled SUBCUTANEOUS CARDIAC STIMULATOR DEVICE HAVING AN ANTERIORLY POSITIONED ELECTRODE.

[0064] The lead 18/20 may be implanted entirely subcutaneously, such as by extending across the anterior or posterior of the chest, or by going partly across the chest in a lateral/medial direction and then superiorly toward the head along the sternum. Some examples and discussion of subcutaneous lead implantation may be found in U.S. Pat. No. 8,157,813, titled APPARATUS AND METHOD FOR SUBCUTANEOUS ELECTRODE INSERTION, and US PG Publication No. 20120029335, titled SUBCUTANEOUS LEADS AND METHODS OF IMPLANT AND EXPLANT, the disclosures of which are incorporated herein by reference. Additional subcutaneous placements are dis-

cussed in U.S. Pat. No. 6,721,597, titled SUBCUTANEOUS ONLY IMPLANTABLE CARDIOVERTER DEFIBRILLATOR AND OPTIONAL PACER, and the above mentioned U.S. Pat. No. 7,149,575, the disclosures of which are incorporated herein by reference. A substernal placement may be used instead, with one finger 18/20 or the entire distal end of the lead (that is, the end distant from the canister 16) going beneath the sternum such as in US PG Patent Pub. No. 2017/0021159, titled SUBSTERNAL PLACEMENT OF A PACING OR DEFIBRILLATING ELECTRODE, the disclosure of which is incorporated herein by reference.

[0065] The devices 14 and 16 may communicate with one another and or with an external programmer 30. The programmer 30 may optionally use a wand (not shown) and/or skin electrodes 32 and 34 to facilitate communication. For example, skin electrodes 32 may be used for conducted communication with an implantable device. Conducted communication is communication via electrical signals which propagate via patient tissue and are generated by more or less ordinary electrodes. By using the existing electrodes of the implantable devices, conducted communication does not rely on an antenna and an oscillator/resonant circuit having a tuned center frequency or frequencies common to both transmitter and receiver.

[0066] For other communication approaches such as RF or inductive communication, the programmer 30 may use a programming wand or may have an antenna integral with the programmer 30 housing for communication. Though not shown in detail, the programmer 30 may include any suitable user interface, including a screen, buttons, keyboard, touchscreen, speakers, and various other features widely known in the art.

[0067] Subcutaneous implantable defibrillators may include, for example, the Emblem S-ICD System™ offered by Boston Scientific Corporation. Combinations of subcutaneous defibrillators and LCP devices are discussed, for example, in US PG Patent Publication Nos. 20160059025, 20160059024, 20160059022, 20160059007, 20160038742, 20150297902, 20150196769, 20150196758, 20150196757, and 20150196756, the disclosures of which are incorporated herein by reference. The subcutaneous defibrillator and LCP may, for example, exchange data related to cardiac function or device status, and may operate together as a system to ensure appropriate determination of cardiac condition (such as whether or not a ventricular tachyarrhythmia is occurring), as well as to coordinate therapy such as by having the LCP deliver antitachycardia pacing in an attempt to convert certain arrhythmias before the subcutaneous defibrillator delivers a defibrillation shock.

[0068] In several examples which follow, the focus is on creating effective CRT therapy through the cooperation of at least two devices 14, 16. In other examples that may use similar concepts for pacing with an LCP using information received from a second device, bradycardia pacing may instead be provided. Several of the below examples may be used to provide bradycardia pacing as a therapy for those with atrioventricular (AV) block, in which the electrical signals that cause contraction of the atria fail to be conducted to the ventricles. For such patients, the SICD 16 (or other second device, such as an atrially placed LCP or detection apparatus, or a subcutaneous monitor) may detect the

P-wave and issue a communication to the LCP 14 commanding or requesting pace therapy, or simply indicating that the P-wave was noted.

[0069] In some examples, rather than a therapy device such as the subcutaneous defibrillator 16 shown in FIG. 1, a second implantable medical device may take the form of an implantable monitoring device. A cardiac monitor may be, for example, a loop monitor that captures data under select conditions using two or more sensing electrodes on a housing thereof and/or attached thereto with a lead. Such monitors have found use to assist in diagnosing cardiac conditions that may be infrequent or intermittent, or which have non-specific symptoms. For example, tracking unexplained systole or determining other cardiac conditions may be done with an implantable or even wearable cardiac monitor. In the context of the present invention, the implantable, or even wearable, cardiac monitor may be used in place of the subcutaneous defibrillator as described in any of the following examples.

[0070] Several examples focus on using a left ventricular LCP 14. However, some examples may instead use a right ventricular LCP 40, and other examples may include both the left ventricular LCP 14 and right ventricular LCP 40. For example, where the use of an LCP is mentioned relative to bradycardia pacing for patients with an AV block, there may be a right ventricular LCP, with or without the left ventricular LCP. In other examples, a three implant system may include two LCP devices 14, 40, as well as a subcutaneous device such as the SICD 16. In still other examples, an atrial-placed LCP (not shown) may also be included.

[0071] FIG. 2 illustrates a block diagram of an implantable medical device. The illustration indicates various functional blocks within a device 50, including a processing block 52, memory 54, power supply 56, input/output circuitry 58, therapy circuitry 60, and communication circuitry 62. These functional blocks make up the operational circuitry of the device. The I/O circuitry 58 can be coupled to one or more electrodes 64, 66 on the device 50 housing, and may also couple to a header 68 for attachment to one or more leads 70 having additional electrodes 72. The communication circuitry 62 may be coupled to an antenna 74 for radio communication (such as Medradio, ISM, or other RF), or alternatively to a coil for inductive communication, and/or may couple via the I/O circuitry 58 to a combination of electrodes 64, 66, 72, for conducted communication.

[0072] The processing block 52 will generally control operations in the device 50 and may include a microprocessor or microcontroller and/or other circuitry and logic suitable to its purpose. Processing block 52 may include dedicated circuits or logic for device functions such as converting analog signals to digital data, processing digital signals, detecting events in a biological signal, etc. The memory block may include RAM, ROM, flash and/or other memory circuits for storing device parameters, programming code, and data related to the use, status, and history of the device 50. The power supply 56 typically includes one to several batteries, which may or may not be rechargeable depending on the device 50. For rechargeable systems there would additionally be charging circuitry for the battery (not shown).

[0073] The I/O circuitry 58 may include various switches or multiplexors for selecting inputs and outputs for use. I/O circuitry 58 may also include filtering circuitry and amplifiers for pre-processing input signals. In some applications

the I/O circuitry will include an H-Bridge to facilitate high power outputs, though other circuit designs may also be used. Therapy block 60 may include capacitors and charging circuits, modulators, and frequency generators for providing electrical outputs. An implantable monitoring apparatus may omit the therapy block 60 and may have a simplified I/O circuitry used simply to capture electrical or other signals such as chemical or motion signals.

[0074] Communications circuitry 62 may include a frequency generator/oscillator and mixer for creating output signals to transmit via the antenna 74. Some devices 50 may include a separate or even off-the shelf ASIC for the communications circuitry 62, for example. For devices using an inductive communication output, an inductive coil may be included. Devices may also use optical or acoustic communication approaches, and suitable circuits, transducers, generators and receivers may be included for these modes of communication as well or instead of those discussed above.

[0075] As those skilled in the art will understand, additional circuits may be provided beyond those shown in FIG. 2. For example, some devices 50 may include a Reed switch, Hall Effect device, or other magnetically reactive element to facilitate magnet wakeup, reset, or therapy inhibition of the device by a user, or to enable an MRI protection mode. A device lacking a lead may have plural electrodes on the housing thereof, as indicated at 64, 66, but may omit the header 64 for coupling to lead 70. In one example, a leadless device may use a header to couple to an electrode support feature that is attached to or wraps around the device housing.

[0076] FIG. 3 shows an illustrative LCP design. The LCP 100 is shown as including several functional blocks including a communications module 102, a pulse generator module 104, an electrical sensing module 106, and a mechanical sensing module 108. A processing module 110 may receive data from and generate commands for outputs by the other modules 102, 104, 106, 108. An energy storage module is highlighted at 112 and may take the form of a rechargeable or non-rechargeable battery, or a supercapacitor, or any other suitable element. Various details of the internal circuitry, which may include a microprocessor or a state-machine architecture, are further discussed in US PG Patent Publications 20150360036, titled SYSTEMS AND METHODS FOR RATE RESPONSIVE PACING WITH A LEADLESS CARDIAC PACEMAKER, 20150224320, titled MULTI-CHAMBER LEADLESS PACEMAKER SYSTEM WITH INTER-DEVICE COMMUNICATION, 20160089539, titled REFRACTORY AND BLANKING INTERVALS IN THE CONTEXT OF MULTI-SITE LEFT VENTRICULAR PACING, and 20160059025, titled, MEDICAL DEVICE WITH TRIGGERED BLANKING PERIOD, as well as other patent publications. Illustrative architectures may also resemble those found in the Micra™ (Medtronic) or Nanostim™ (St. Jude Medical) leadless pacemakers.

[0077] The device is shown with a first end electrode at 114 and a second end electrode at 116. A number of tines 118 may extend from the device in several directions. The tines 118 maybe used to secure the device in place within a heart chamber. Another attachment structure is shown at 120 and may take the form of a helical screw, if desired. In some examples, tines 118 are used as the only attachment features. Tissue attachment and retrieval features may be included in the LCP including those features shown in US PG Patent Publications 20150051610, titled LEADLESS CARDIAC

PACEMAKER AND RETRIEVAL DEVICE, and 20150025612, titled SYSTEM AND METHODS FOR CHRONIC FIXATION OF MEDICAL DEVICES, the disclosures of which are incorporated herein by reference. Fixation and retrieval structures may instead resemble that of the Micra™ (Medtronic) or Nanostim™ (St. Jude Medical) leadless pacemakers.

**[0078]** FIG. 4 shows an illustrative cardiac signal. A far field representation (that is, a signal captured using only electrodes that are neither in nor on the heart) is shown with trace **150**. The trace **150** is marked using standard convention with the P-wave, R-wave (which, when combined with preceding Q-wave and following S-wave may be referred to as the QRS complex), and later T-wave. The P-wave represents atrial depolarization associated with atrial contraction to load the ventricles, the R-wave or QRS complex represents ventricular depolarization associated with the ventricles contracting to pump blood to the body and lungs, and the T-wave is associated with the electrical activity that repolarizes the ventricular muscle in preparation for a next beat. With heart failure and/or dyssynchrony, the timing of these individual events may be anomalous or abnormal, and the shape of depolarization waves can be different from that show as by, for example, having a much wider QRS complex or R-wave.

**[0079]** With traditional systems having transvenous leads, the intracardiac electrodes are placed to detect the atrial depolarization while also delivering resynchronizing pacing therapy to one or both ventricles. As a result, the circuitry of a single device would receive, directly, information for the P-wave allowing delivery at a timed interval of a pacing pulse to resynchronize contractions and improve pumping efficiency. However, with a system as in FIG. 1, the LCP may be unable to identify the P-wave generated in the atria from an implanted location in the ventricle. Therefore the LCP, in several embodiments of the present invention, relies on a second medical device such as a subcutaneous cardiac monitor or SICD to determine whether and when the P-wave occurs. However, to facilitate such interaction, the present inventors have identified several potential optimizations.

**[0080]** For example, the SICD (or subcutaneous cardiac monitor) may be optimized for detection of R-waves and/or QRS complexes, in order to ensure that deadly arrhythmias (ventricular fibrillation and/or polymorphic ventricular tachycardia) can be appropriately and quickly identified. P-waves may be detected using separate parameters and/or analysis from R-wave detection for such a device. In some examples, a time window for P-wave detection is defined during which the SICD may specifically look for the P-wave. Such windows may be defined by analysis of the cardiac signals obtained from a patient using, for example, a ventricular event such as the R-wave/QRS complex or the T-wave as the starting point for timing delays **152**, **154** shown in FIG. 4. Durations **152**, **154** may be dynamic to adjust to the overall beat rate of the patient using data gathered from a patient or using a formula or accepted relationship.

**[0081]** Another optimization may include having the SICD (or subcutaneous cardiac monitor) use a dedicated sensing configuration to separately detect ventricular events and a second, separately defined dedicated sensing configuration to separately detect atrial events. For example, the Emblem™ S-ICD system performs vector selection to identify a sensing vector having optimal R-wave amplitude and

signal to noise ratio as a default vector for sensing the patient's cardiac rhythm, as disclosed for example in U.S. Pat. No. 7,783,340, titled SYSTEMS AND METHODS FOR SENSING VECTOR SELECTION IN AN IMPLANTABLE MEDICAL DEVICE USING A POLYNOMIAL APPROACH, and U.S. Pat. No. 8,483,843 SENSING VECTOR SELECTION IN A CARDIAC STIMULUS DEVICE WITH POSTURAL ASSESSMENT, the disclosures of which are incorporated herein by reference. Related concepts are also disclosed in US PG Patent Pub. Nos. 2017/0112399, 2017/0113040, 2017/0113050, and 2017/0113053, the disclosures of which are incorporated herein by reference. In an example, a second vector selection and/or sensing configuration process may be used to determine how the P-wave will be detected by a given device.

**[0082]** In further examples, filtering, gain, or other characteristics may be selected specific to P-wave detection. For example, if a ventricular event sensing channel uses a first passband, a P-wave sensing channel passband may be set to a different passband. For example, the R-wave or ventricular event passband may be set in the range of 3-40 Hz, or 9-40 Hz, or other setting. The P-wave passband may be set to a different range, for example, 0.5 to 20 Hz. Such band setting and selection may be partly contingent on reviewing the captured signal of either or both of ventricular and/or atrial events. Methods as discussed in US PG Patent Pub. No. 2017/0156617, titled AUTOMATIC DETERMINATION AND SELECTION OF FILTERING IN A CARDIAC RHYTHM MANAGEMENT DEVICE, the disclosure of which is incorporated herein by reference, may be used to select a sensing channel passband(s). In another example, a passband may be varied until signal amplitude for the desired atrial or ventricular feature begins to drop, at which an edge or corner of the passband may be set, to achieve a targeted, narrow passband. Thus a P-wave sensing or atrial sensing configuration may use a different frequency band than a corresponding R-wave sensing or ventricular event filter. Alternatively, a single passband may be set for use in each of atrial and ventricular sensing, or different pre-set ranges may be used for each of atrial and ventricular sensing

**[0083]** Setting the sensing configuration for detecting P-waves may thus include either or both of setting a detection window and/or selecting a filter configuration. In addition, the actual manner of detecting the P-wave is defined in some illustrative examples as part of the sensing configuration. For example, the P-wave may be detected by comparing a detected signal to a fixed or time-varying amplitude threshold. In another example, the P-wave may be detected by comparing segments of captured signal to a template until a match is found or at timeout occurs. When a match is found a P-wave detection can be declared; if a timeout occurs, it may be concluded that the P-wave was not present or simply not seen. In some examples, more than one method of identifying P-waves may be available for use, and a most effective approach for a given patient may be selected. For example, if amplitude threshold and template match approaches to P-wave detection are available, a patient having highly variable amplitude signals may have his or her device configured to use the template match approach rather than an amplitude based approach.

**[0084]** In some examples, a possible P-wave is confirmed as such prior to generating an output communication. For example, a template of the P-wave may be defined and used to confirm whether a detected signal that crosses an ampli-

tude threshold is in fact a P-wave by comparing the detected signal to the template. Such templates may be static and stored in memory, may be matched from one beat to the next by comparing a first in time P-wave to a next in time possible P-wave, or may be a hybrid of a stored template and fully dynamic template as by, for example, averaging in newly detected P-waves to a template.

**[0085]** In some examples, patients may be pre-screened for P-wave availability with the second medical device that is to be used for synchronizing LCP pacing. For example, it may well be that due to anatomical variations or other factors, some patients will have a well-defined P-wave providing a ready fiducial for the SICD or subcutaneous cardiac monitor to rely upon to prompt CRT therapy by an LCP. In other patients, the P-wave may be difficult to detect consistently. Thus a pre-screening process may be performed, either as an in-clinic test, or by having a patient use a Holter monitor or by implanting a subcutaneous cardiac monitor to ensure that the P-wave is readily identified consistently.

**[0086]** The below examples further illustrate these optimizations and give examples of how such optimizations may be incorporated in a combination system having an LCP and a second implantable device, such as an SICD or a subcutaneous cardiac monitor, to generate and communicate timing information to the LCP for CRT purposes. First, however, FIGS. 5A-5B, 6 and 7 will show additional details in relation to the detected cardiac electrical signal.

**[0087]** FIG. 5A shows another illustrative cardiac signal, this time with indications of a pacing therapy being delivered. The trace is shown at 170 with an intrinsic non-paced R-wave shown at 172. This R-wave at 172 is a fiducial for a time period 174 that defines a P-wave detection window at 176. In an alternative, a maximum positive slope point associated with the T-wave, indicated at 180, may serve as the fiducial for a duration 182 that again defines the P-wave detection window 176. In some examples, these interactions may be described by stating that a ventricular event is used to generate the fiducial for a window detection of the atrial event.

**[0088]** Various features of the signal 170 may serve as the fiducials for starting durations 174/182 in FIG. 5A. FIG. 5B shows example timing fiducials for a signal. A signal 200 may cross an amplitude threshold, creating a fiducial at 202 when going up, or another fiducial at 204 when coming back down. An amplitude peak 206 may instead be used. Alternatively, an inflection 208 may be used, with either positive slope or negative slope inflections available. In still another example, a fiducial 210 may rely on the area under the curve crossing a defined threshold. Any of these, or other, fiducials may be used to establish a point in time from which counting begins for purposes of defining a P-wave detection window. Fiducials may be applied to a prior P-wave, to a QRS complex, to an R-wave, or to the T-wave. The ST segment may be used if desired as by, for example, calculating a mid-point or other feature thereof.

**[0089]** Returning to FIG. 5A, if a P-wave is detected and, in some examples, confirmed within the P-wave detection window 176, another fiducial is set at 190 and, following a P-wave to pace delay 192, a pacing therapy is delivered as shown at 194. The delay 192 may be calculated by either the LCP that delivers the pace therapy or by the second device that provides a command to deliver therapy or other information indicating the occurrence of the P-wave. Such delay

192 may encompass and/or accommodate system latency (delays due to the time required to analyze data, make a decision, communicate data, receive communicated data, analyze the received data to determine the purpose of the communication, and generate therapy output).

**[0090]** For illustrative purposes, the pacing therapy 194 is shown as a monophasic, rectangular pulse, however, this is merely for illustration. The pacing pulse may be monophasic or biphasic, with the latter being more common than the former. Typical pace delivery can be either constant current or constant voltage, however, more complex waveforms such as ramped, exponential, and/or triphasic waveforms, or any other suitable waveform, may be used.

**[0091]** In the illustration shown, the pacing therapy 192 stimulates enough of the myocardium, either directly or by augmenting existing neural signals, to capture the heart. As a result, a QRS complex occurs causing beat 196. A brief visual comparison of QRS complex of beat 196 to the non-paced complex for beat 178 shows that, as is typical, the paced beat at 196 has a different shape or morphology than the intrinsic beat 178, with a more exaggerated Q-wave, and a differently shaped S-T segment. Other differences may be noted as is understood in the art. Such differences (or others) may be used, if desired, to aid in having a second device analyze the efficacy of CRT therapy delivered by an LCP.

**[0092]** Detection in the P-wave detection window may take several forms. The obtained cardiac signal may be compared to a P-wave detection threshold, which may be, for example, based on prior P-waves that have been detected. The obtained signal may be analyzed to determine whether a peak slope, combined with an amplitude, occurs. For example, the obtained signal may be analyzed for an upward slope of a select shape lasting for a minimum duration or minimum change in amplitude.

**[0093]** Two examples of P-wave detection are shown in FIGS. 5C and 5D. For example, as shown in FIG. 5C, a signal 220 comprises a first QRS complex at 222. A detection profile for R-wave detection is shown at 224 and may be a time-varying detection profile having a refractory period to pass over the QRS complex, followed by a constant threshold period to pass over the T-wave, followed by a decay period. Once the signal 220 crosses the detection profile 224, a new ventricular event detection is declared, in this case associated R-wave 226. The height of various parts of detection profile 224 may be calculated by reference to one or more previously detected R-waves as discussed in U.S. Pat. No. 8,565,878, for example. P-wave detection takes place in the P-wave detection window at 230. In this example, the P-wave 232 is detected when signal 220 crosses P-wave detection threshold 234. The P-wave detection threshold 234 may be set by reference to the amplitude of one or more previously detected P-waves. Alternatively, the P-wave detection threshold 234 may be scaled relative to the detection profile 224 (such as a 20% to 80%, or more or less of detection profile 224). The P-wave detection may then be used to trigger a pacing pulse (not shown) as described elsewhere in the present document.

**[0094]** FIG. 5D shows another example. Here, a cardiac signal is shown at 240 with a P-wave detection window at 242. The signal in window 242 is expanded as shown at 242'. A P-wave template is shown at 244. To detect the P-wave, a series of comparisons are made as incoming signal is received. Once enough signal is received to perform a morphology comparison, such as by difference of area,

correlation waveform analysis, wavelet transform, or principal components analysis, for example, a morphology comparison is made. The morphology comparison is repeated as more signal comes in, with data entering a comparison window on a first-in, first-out basis, until a match is found at **248**. Match **248** is then the P-wave detection.

**[0095]** In still further examples, a P-wave detection window **242** may be searched to identify a specific feature associated with a possible P-wave. For example, a P-wave may be identified by observing whether a slope in excess of a threshold and with a minimum pathlength occurs during the P-detection window. Additional ways to confirm that a signal is a P-wave are discussed relative to FIG. 6.

**[0096]** FIG. 6 illustrates additional ways that a signal feature such as a P-wave may be analyzed for confirmation purposes. In the example of FIG. 6, a P-wave detection window is defined as shown at **260**. The signal within the window **260**, as shown at **262**, includes a peak. In one example, to confirm that the signal within the window **260** is actually a P-wave, it may be analyzed for having at least a minimum amplitude **264**. In another example, to confirm that the signal within the window **260** is a P-wave, slope characteristics such as a combination of rise and run may be analyzed, as shown at **266**, where the rise is the amount of change of amplitude, and run is the duration within which the amplitude change occurs.

**[0097]** In still another example, matching, using for example a difference of area analysis, correlation waveform analysis, wavelet transform, or principal component analysis, may be used to compare the shape of peak **262** to another signal such as the shape of the signal in a prior P-wave detection window, shown at **250**, using the signal shape therein **254** across all or a portion of the window **250**. A beat-to-beat comparison may be termed a dynamic comparison, as the shape against which the newly detected possible P-wave is compared will change with each new cardiac cycle. In another example, a stored template, such as shown at **280**, may be used. In this example, shape **262** would be compared against the shape **282** defined by the template **280**. If a stored template does not change with time, it may be deemed a static template. A hybrid template may be configured to change slowly with time by averaging an existing data set with a newly detected and confirmed P-wave, or by averaging several preceding P-wave detections.

**[0098]** FIG. 7 shows another cardiac signal to illustrate operation of an embodiment. In this example, the cardiac signal is shown at **300**. A first cardiac cycle is shown at **310** including an intrinsic P-wave, non-paced QRS complex, and trailing T-wave. In the example, the R-wave peak is used as a fiducial at **312** to start a timer that expires with duration **314**, triggering the start of a P-wave detection window **316**. During the P-wave detection window **316**, the SICD or subcutaneous cardiac monitor searches for a P-wave. The operation during the detection window **316** may include selecting a specific sensing configuration (sensing vector, filtering or the like) to observe for an atrial event such as the P-wave.

**[0099]** In the illustration of FIG. 7, an atrial sense occurs at **320**, corresponding in this example to the peak amplitude of the P-wave. A delay is instituted at **322** prior to delivery of a ventricular pacing stimulus at **324**. In one example, the delay **322** is a calculated delay, which may include a lag period to allow for analysis by the SICD or subcutaneous cardiac monitor, transmission of data or a command to an

LCP, processing by the LCP, plus, if desired, some intentional delay to allow for appropriate timing of the pace pulse **324** to optimize pacing efficiency. For example, in a transvenous CRT system, an AV delay control may be used to institute appropriate delay from a P-wave or atrial event sense to the delivery of ventricular pacing therapy. In a system as disclosed herein, the AV delay can include both system lag as well as intentional delay.

**[0100]** A device may include special handling instructions for communication to the LCP during period **322**, to count how many retries occur in the event that a communication message is not received or acknowledged appropriately. Thus, if for some reason (such as external interference), the initial communication from the SICD or subcutaneous cardiac monitor the LCP is not received, subsequent tries may indicate how many retries have occurred to allow the LCP to appropriately manage period **322**. If there are multiple retries, the pacing pulse **324** may be inhibited, if desired, to avoid extending period **322** beyond a set limit. Rather than relying on a quantity of retries, the LCP may simply timeout.

**[0101]** Continuing the example, the P-wave at **320** is the start of a new cardiac cycle **330**, which in this case now includes a paced QRS complex at **332** having a distinct morphology relative to the first complex **310**. In this example, with a pace captured QRS complex **332**, the device may alter its selection of fiducials to define a next P-wave detection window, shown at **342**. For example, in FIG. 7, the delay **340** is now instituted from the pace delivery at **324**, rather than the R-wave. The next atrial event or P-wave detection window is shown at **342**. Again an atrial sense occurs at **344** at the peak of a P-wave, and following a delay **346** (which may again include both system lag and intentional delay), a pacing therapy pulse is delivered at **348** again causing a pace-captured QRS complex shown at **350**. Depending on system settings, the delay at **346** may be the same as, or different from, the delay at **322**, if desired.

**[0102]** FIGS. 8, 9, and 10A-10B show block diagrams for illustrative examples. In the example of FIG. 8, the overall method of using an implantable medical device is shown at **400**. The device or system is initialized at **402**, following which treatable conditions are detected at **404** and treatment is delivered at **406**. For implantable cardiac systems such as shown in FIG. 1, treatment **406** may include delivering a therapy shock for ventricular fibrillation or polymorphic tachyarrhythmia, as indicated at **410**. For example, an SICD may deliver a defibrillation shock at **410**. Alternatively, antitachycardia pacing (ATP) may be delivered as shown at **412**. For example, an LCP may deliver ATP in response to a request or command by an SICD, or of its own accord. An SICD may also deliver ATP if desired. Bradycardia pacing may be delivered by one or the other of an LCP or SICD, with the LCP likely being preferred due to the possible discomfort that SICD pacing delivery can cause the patient. In some examples, the Bradycardia pacing may be delivered to treat AV block using a right ventricular LCP. Finally, as detailed herein, CRT pacing may be delivered at **416**.

**[0103]** Adjustments to the system configuration and other settings may be performed as indicated at **420**, for example, in response to the various therapies **410**, **412**, **414**, **416**. For example, if CRT pacing **416** is delivered but fails to generate fusion beats, an adjustment may be made to the timing between P-wave detection and pacing delivery, or to the duration, amplitude, or other characteristics of the delivered pacing therapy. In another example if bradycardia pacing

**414** is delivered but fails stimulate a ventricular contraction, the delivered therapy may be adjusted **420** by using a different amplitude, pulse width, or shape.

[**0104**] Returning to the initialization block, as discussed above and below, there may be several settings to configure during initialization **402**. For example, sensing configuration (sense vectors and filtering, for example, for one or both of ventricular and/or atrial event detection) may be established during initialization to optimize sensing of ventricular and/or atrial events. Communication operations may be initialized as well, for example as discussed in U.S. patent application Ser. No. 15/070,013, titled COMMUNICATIONS IN A MEDICAL DEVICE SYSTEM WITH LINK QUALITY ASSESSMENT, and/or Ser. No. 15/058,412, titled COMMUNICATIONS IN A MEDICAL DEVICE SYSTEM WITH TEMPORAL OPTIMIZATION, the disclosures of which are incorporated herein by reference.

[**0105**] FIG. 9 shows a more detailed discussion of initialization relative to sensing parameters. In the example method **450**, initializing data is obtained as indicated at **452**, and one or more sensing vectors are selected, as indicated at **470**. Next, the detection parameters such as parameters for detecting P-waves or atrial events (P-Detect Parameters) are set, as indicated at **480**. Generally speaking, steps **452**, **470** and **480** focus on the operations of the SICD or subcutaneous cardiac monitor for a system such as shown in FIG. 1 having both a subcutaneously located device along with an LCP. However, the LCP may also be setup for sensing configuration to optimize its ability to detect signals originating in whatever chamber of the heart the LCP is located in, and/or to filter out noise signals.

[**0106**] The step of obtaining initializing data at **452** may include various subprocesses as indicated on the left side of FIG. 9. For example, as indicated at **454**, a plurality of individual cardiac cycles may be detected at **456** in one or several sensing vectors or with one or several different sensing configurations (affecting for example, filtering and/or amplification parameters, possibly in combination with vector selection parameters). The individual detections of cardiac cycles may be analyzed **458** by, for example, binning different detected data elements from each cycle as discussed in U.S. Pat. No. 7,783,340, titled SYSTEMS AND METHODS FOR SENSING VECTOR SELECTION IN AN IMPLANTABLE MEDICAL DEVICE USING A POLYNOMIAL APPROACH. As an alternative shown at **460**, a set of cardiac cycles are detected as indicated at **462** and a composite signal is generated as shown at **464**. The use of a composite signal to establish sensing vector quality metrics is discussed, for example, in US PG Patent Pub. No. 2017/0113053, titled SIGNAL QUALITY MONITORING FOR MULTIPLE SENSE VECTORS IN CARDIAC DEVICES, the disclosure of which is incorporated herein by reference.

[**0107**] Next, in block **470**, sense vector configurations for ventricular (targeting, for example, R waves, the QRS complex, and/or T-waves) and/or atrial event detection (targeting, for example, the P-wave) are selected. The vector configuration may include selecting combinations of electrodes to use, combinations of two or more vectors to use together, and/or the setting of filtering, blanking, refractory, amplification or other parameters. Various approaches to vector selection may be used including those referenced above from other patents or patent applications, as well as those discussed herein. For example, consistency of a vector

configuration may be used, as indicated at **472**, to select a given vector. Consistency **472** may mean, for example, that a selected cardiac event (P, R or T waves, or the QRS complex) is consistent in shape, amplitude and/or timing, in a given vector configuration. Alternatively or in combination with consistency, strength **474** of the signal, absolute and/or relative to noise may be considered as well.

[**0108**] In some examples, once vector configuration is set, the parameters for identifying P-waves are set as indicated at **480**. In an alternative, as indicated by the line at **490**, the sensing configuration step may be bypassed, and P-Detect parameters set at **480**. For example, block **470** may be performed in some embodiments only when connected to a clinician programmer to ensure that appropriate signals are obtained and/or that sensing configuration is not modified contrary to known patient history, while blocks **452** and **480** may be performed by a device independent of programmer intervention. In some examples, on the other hand, block **480** may be omitted, with the sensing vector setup performed and any suitable method of P-wave detection used by the device without necessarily performing a separate optimization at **480**.

[**0109**] Block **480** calls for setting one or more parameters to optimize P-wave detection. In some examples, this may include selecting one or more of the fiducials from which P-wave detection is triggered, at **482**, setting a window for detecting the P-wave **484**, selecting the features to look for when attempting to detect a P-wave **486**, or selecting a template for P-wave confirmation at **488**. Any of blocks **482**, **484**, **486**, **488** may be used in various combinations or, in some examples, standing alone.

[**0110**] For example, the fiducial selection at **482** may be used to select a feature (whether atrial or ventricular, such as an R-wave, a T-wave, a preceding P-wave, or other physiological, such as a heart sound, a blood pressure signal, or other timing point of reference such as delivery of a pacing pulse), that starts a blanking period during which P-waves cannot be detected, for example, to pass over the T-wave, and upon expiration of the blanking period, P-wave detection is enabled. Alternatively, the fiducial **482** may be used to trigger the initiation of an analysis window for the P-wave. The window **484** may be used as shown above in FIGS. 5A, 6 and 7 by, for example, determining relative to a selected fiducial point when the P-wave typically appears and then setting a window of a duration equal or longer than the P-wave for allowing P-wave detection. The window may be, for example, about 50 to 400 milliseconds. In another example, the window may be about 100 to about 200 milliseconds. Other durations may be used.

[**0111**] Which features to use for identifying the P-wave is another element, as indicated at **486**. For example, a P-wave may be identified by having an amplitude of a certain range, such as greater than a threshold. A threshold may be adaptive to current patient conditions by, for example, setting it to some percentage (50% to 90%, or more or less) of a preceding P-wave or an average of several preceding P-waves, or stored information relating to typical P-waves generally or specific to a given patient. Other features may include a maximum or minimum slope amplitude or length. In an example, the P-wave may be identified by the detected signal moving in a certain direction within predefined slope parameters for at least a predetermined amplitude or period of time. Thus, for example, the signal may have an upward slope that is characteristic of the P-wave, not so steep as for

the R-wave, but steeper than the T-wave, of at least a select duration to avoid noise detection. Slope analysis may take place by using the first or second derivative of the obtained signal. Other features may be used instead at block 486.

[0112] The template 488 may also be used independent of other items to detect a P-wave. For example, the template may be compared to received data on a continuous or semi-continuous basis, and when a match is found, a P-wave may be declared (see FIG. 5d, above). The template may be an averaged composite of prior signals, or may be simply a prior P-wave, or may be constructed in any other suitable manner. The incoming signal itself may be a signal averaged composite of several cardiac cycles having, for example, P, Q, R and S signals (and T-waves if the composite is so configured).

[0113] In an example, during a window defined using 484, a template may be compared to an incoming data stream to identify a match. In other examples, the template 488 may be used to confirm a detected likely P-wave, such as a signal that crosses a defined amplitude threshold during a P-wave detection window. If the template 488 matches the likely P-wave, then P-wave detection is confirmed or, alternatively, if there is no match to the template 488, then the detection may be discarded as not being a P-wave.

[0114] FIGS. 10A-10B show summary characterization of two approaches to sensing configuration. As shown in FIG. 10A, data is captured at 500. Next, VT/VF sensing 502 configuration and parameters are set by, for example, setting up sensing vectors and filtering, storing morphology information (templates, wavelet transforms or the like known in the art) for differentiating normal from abnormal cardiac activity, and the like. Finally, sensing configuration to be used for bradycardia therapy and/or CRT therapy control is set at 504. Block 504 may include configuring sensing vectors or combinations, filtering, and the like, as well as template selection, window setting and fiducial assessment, or other steps noted both above and below.

[0115] FIG. 10B shows another characterization. Here, data is obtained at 510, following by setting ventricular sensing parameters at 512. Ventricular sensing 512 parameters may be optimized to detect R-waves and/or VT/VF signals, including filtering and vector selection or combinations, as well as threshold setting and/or template formation. Atrial sensing parameters are set at 514, and may include optimization to detect P-waves or other atrial events including filtering, windowing and vector selection or combinations, as well as threshold setting and/or template formation.

[0116] FIG. 11 shows in block flow form operation of two cooperating devices. A first device performs operations as shown at 600, while a second device performs operations as shown at 620. Communications between the device are shown at 610, 612, though it should be understood that additional back and forth communication may also take place during device operations.

[0117] At a first point in time, each device is sensing for cardiac activity, as shown at 602, 622. For example, during block 602, Device 1 (which may be an SICD or subcutaneous cardiac monitoring device), may perform sensing for ventricular and/or atrial events, such as observing for R-waves, T-waves, or P-waves. Device 2 (which may be an LCP), may or may not perform sensing. In some examples, Device 2 may omit sensing and may instead simply rely upon Device 1 for therapy directions. In other examples, both devices sense for cardiac (or other) activity. For

example, in block 622, Device 2 may observe whether a ventricular extra-systole event such as a premature ventricular contraction (PVC) occurs, or whether the ventricles otherwise “beat” before an atrial event is detected. (see FIG. 18, below for such exception handling).

[0118] At 604, Device 1 detects a trigger. The trigger may be, for example, an atrial event such as a P-wave. For example, the P-wave may be detected during a P-wave detection window, or may be detected by comparing a received signal to a template. If desired, the P-wave may be both detected and confirmed by using a detection method (comparing to an amplitude during a P-wave window, for example) and a confirmation method (comparing a possible P-wave signal to a template).

[0119] Device 1 then communicates out, as shown at 606, issuing a communication to Device 2, which is then received at Device 2. The communication may command or request a therapy delivery, or may indicate that a P-wave has been detected. For example, in a Master-Slave relationship, Device 2 may receive a command for pacing therapy and simply respond by generating a pacing output. In other interactions, Device 2 may receive a request for therapy delivery and proceed to deliver the requested therapy unless an exception arises before or after the request is received. In yet another interaction, Device 2 may receive an indication that a P-wave has been observed by Device 1, and Device 2 may then determine whether pacing or other therapy is appropriate.

[0120] After receiving the communication at 624, in the example shown, Device 2 delivers therapy at 626. Either or both of the two devices may, optionally, confirm that therapy was effective at 608 and 628. This confirmation may be communicated between the devices, as indicated at 612. For example, Device 1 may confirm that therapy was effective by observing the morphology of the cardiac signal following therapy delivery using, for example, a paced beat template. Device 2 may confirm that therapy was effective by observing morphology or by any other suitable manner. Alternatively, communication 612 may be omitted. For example, Device 1 may restart its sensing cycle following detection of an evoked response to therapy 626, or after detecting therapy 626; Device 2 may restart its sensing cycle following delivery of therapy 626.

[0121] While only two devices are represented in FIG. 11, additional devices may be involved. For example, a third device may be an LCP that functions similar to Device 2. For example, a first LCP may have a right ventricular location and a second LCP may have a left ventricular location, allowing biventricular pacing to be delivered, with both LCP devices generating therapy output relying for timing information upon Device 1’s detection of an atrial event. If two LCP devices are included, each may be separately programmed to delay therapy 626 from the trigger detected at 604 to achieve desirable resynchronization characteristics. Such timing, either with a single or plural LCP devices involved, may be addressed in part using methods illustrated by FIGS. 12A-12B.

[0122] FIGS. 12A-12B illustrate different manners of handling cross-device timing. In this example, the operation of an LCP is illustrated in which the LCP receives a communication at 650. The communication includes a timestamp associated with the time at which a therapy trigger was identified by the SICD, which timestamp is extracted from the communication in block 652. The timestamp may be a

relative timestamp as indicated at 654. A relative timestamp may be based on a system event such as the point in time of a prior communication, or of a prior therapy delivery as detected by the SICD. For example, the SICD may be capable of determining when a pacing pulse is delivered by the LCP, and may communicate the timing of a detected trigger relative to the LCP prior pacing pulse; in this way, the LCP need not synchronize its clock to the SICD and instead simply tracks when it last delivered a therapy. Alternatively, the timestamp may be based on a synchronization clock signal as indicated at 656, where one of the devices (LCP or SICD) includes a system clock to which each device is synchronized. Using the timestamp, the LCP determines when, relative to the trigger event, therapy should be delivered as indicated at 660.

[0123] FIG. 12B shows a somewhat simpler approach. A communication is received at 680, and therapy is delivered based at 682, without relying on a timestamp of the communication. Here, the LCP determines when it received the communication and determines when to deliver therapy based on the communication time. The method of FIG. 12B relies, in part, on an assumption that the time from a trigger event to communication is predictable and repeatable. As is known to those skilled in the art, communication retries can occur when a communication is issued but not acknowledged by the intended recipient. Retries would therefore potentially delay therapy in the method of FIG. 12B. To facilitate accuracy, the communication provided from the SICD may indicate whether it is the first communication in response to a given trigger, or whether it is a retry, such that the LCP can adjust its timing according to whether there have been one or more communication retries.

[0124] FIGS. 13-18 show in block flow format operations of two cooperating devices. As noted for FIG. 11, there may be more than just the two devices represented in these drawings, with additional LCP devices operating similar, in some examples, to "Device 2" of the Figures.

[0125] FIG. 13 illustrates operations for Device 1 (which may be an SICD or a subcutaneous cardiac monitor) at 700 and Device 2 (which may be an LCP) at 720. In this example, each of the devices sense obtained signals looking to detect one or more predefined events. Device 1 detects a trigger event, such as an atrial event or P-wave, as indicated at 704. However, Device 2 also detects an inhibiting event as indicated at 724. An inhibiting event may be, for example, a QRS complex or an R-wave, or a PVC. Such detection at 724 may occur by, for example, comparing received signals against a threshold defined at a high enough amplitude to pass over typical P-waves and/or T-waves. The presence of the inhibitor at 724 causes Device 2 to withhold therapy as shown at 726 in this example. Thus, when Device 1 communicates out at 706 in response to detecting the trigger at 704, Device 2 may respond to the communication at 710 by ignoring it, or by providing a response to Device 1 to indicate that no therapy will be delivered due to the inhibitor having been detected. The two devices may, as before, confirm status at 708, 728, with or without communication 712 therebetween.

[0126] FIG. 14 shows another example with operations for Device 1, which may be an SICD or a subcutaneous cardiac monitor, shown at 750, and for Device 2, which may be an LCP, at 770. Here, Device 1 applies its sensing for a trigger at 752, however, no trigger is detected at 754. Device 2 also senses at 772, but encounters a timeout without detecting an

inhibiting event and without receiving a communication from Device 1 indicating that therapy should be delivered. Such a scenario may, in some examples, inhibit therapy entirely. In this example, however, Device 2 delivers therapy at 776 in response to a timeout at 774. The timeout 774 may occur if a relevant escape interval expires for a patient who is both pace dependent and receiving CRT, for example. Again the devices may confirm status at 756, 778 with or without communication therebetween at 760.

[0127] FIG. 15 shows another example with operations for Device 1, which may be an SICD or a subcutaneous cardiac monitor, shown at 800, and for Device 2, which may be an LCP, at 820. Each of Device 1 and Device 2 apply sensing parameters at 802, 822, respectively. Device 1 detects a trigger at 804 and communicates out to Device 2 at 806, commanding or requesting therapy, or simply indicating presence of the trigger 804. Device 2 receives communication 810 at 824, and then delivers therapy 826 in response to (and after a determined delay relative to) the trigger. In this example, however, Device 1 continues sensing after the Communication out at 806, and determines that therapy failed to capture the heart. Such failure may be determined by either the absence of an R-wave or QRS complex in response to the therapy 825, or by analyzing the R-wave or QRS complex that does occur and determining it does resemble a captured beat (by for example determining a capture template is not matched), or that it occurred at a time indicating no capture (that is, the responsive contraction may occur too late or too early to have been a response to the stimulus).

[0128] In the example of FIG. 15, the therapy failure 808 is then communicated to Device 2, which modifies therapy at 828. Therapy modification 828 may include, for example, changing therapy amplitude, pulse width or other shape/energy characteristic, changing the timing of therapy by increasing or reducing a delay from the trigger, changing a therapy polarity, polarity type, or electrode configuration, or by changing other suitable therapy characteristic(s). The specific therapy modification 828 may be determined by either of Device 1 or Device 2. In this example, following non-capture, the devices return to sensing. Device 2, in this example, may store new pacing parameters for use in a next iteration.

[0129] FIG. 16 shows an alternative to FIG. 15. Operations for Device 1, which may be an SICD or a subcutaneous cardiac monitor, are shown at 850. Operations for Device 2, which may be an LCP, are shown at 880. Each of Device 1 and Device 2 apply sensing parameters at 852, 882, respectively. Device 1 detects a trigger at 854 and communicates out to Device 2 at 856, commanding or requesting therapy, or simply indicating presence of the trigger 854. Device 2 receives communication 870 at 884, and then delivers therapy 886 in response to (and after a determined delay relative to) the trigger.

[0130] In the example of FIG. 16, however, Device 1 continues sensing after the Communication out at 856, and determines that therapy failed to capture the heart as indicated at 858. Here, it would be determined that there was no response to therapy 886 and the heart has not yet had a contraction. A communication is issued at 872 in response to the finding that therapy failed at 858, and therapy is retried at 888 by Device 2. Plural retries may take place, and the retry of therapy may occur with changed parameters including increasing amplitude and/or pulse width, changing

polarity, polarity type or electrode configuration, or by changing other suitable therapy characteristic(s). Once a beat occurs, either through capture or intrinsic, the devices confirm that the heart beat took place at **860, 890**, with or without communication therebetween **874**. Device **2**, in this example, may store new pacing parameters for use in a next iteration. The scenario of FIG. **16** is less likely to be needed in many CRT patients; instead, those who are pacemaker dependent, for example having an AV block, may benefit by use with right ventricular placed LCP (see item **40**, FIG. **1**).

[0131] FIG. **17** shows another illustrative example. Operations for Device **1**, which may be an SICD or a subcutaneous cardiac monitor, are shown at **900**. Operations for Device **2**, which may be an LCP, are shown at **920**. Each of Device **1** and Device **2** apply sensing parameters at **902, 922**, respectively. Device **1** detects an inhibitor at **904** which may be, for example, a QRS complex, an R-wave, or a PVC. In some examples, Device **1** may detect an inhibitor **904** as a premature atrial contraction (PAC). In response to the inhibitor, as shown at **906**, Device **1** may generate a communication **910** to Device **2**. Device **2** receives the communication at **924**, and inhibits therapy as indicated at **926**. The two devices may confirm status at **908, 928**, with or without communication **912** therebetween. The scenario of FIG. **17** may arise, for example, if Device **2** is configured to deliver therapy at a given interval absent an inhibition command.

[0132] For each of FIGS. **13** and **17**, special parameters may be applied following the identification of an inhibiting event for use in a subsequent cycle, as contrasted to parameters for use following a pace-captured beat. For example, following an inhibiting event, parameters for sensing may be modified to use different periods and fiducials for the starting point of timeouts. Referring briefly to FIG. **7**, for example, the following may change depending on whether an intrinsic beat (shown at **302**) or paced beat (shown at **332**) occurs:

[0133] The first delay period **314** may be different from the second delay period **340**;

[0134] The first P-wave detection window **316** may use different duration, filtering, or detection parameters (such as amplitude or slope thresholds, or P-wave template) than the second P-wave detection window **342**;

[0135] The first delay **322** may be different from the second delay **346** preceding pacing therapy delivery; and/or

[0136] The first pacing therapy **324** may have different amplitude, polarity, polarity type, pulse width or other parameters from the second pace therapy **348**

A third (or more) set of parameters may apply to any of these variables in the event that a PVC or PAC occurs, rather than a QRS complex. Additional exception rules may be defined if, for example, some element of a fiducial or detection window encounters an unusual event. For example, if using the T-wave peak as a fiducial for timing a P-wave detection window, the T-wave peak may be required to demonstrate certain characteristics such as a minimum amplitude, or a particular polarity, to be deemed suitable as the fiducial. If the fiducial event does not occur in an expected manner, additional exception rules may apply.

[0137] FIG. **18** shows a pre-implantation process flow. A patient having appropriate indications for CRT is first identified as indicated at **950**. Such indications are well known in the art any may include, for example, a wide QRS complex, left bundle branch block, the New York Heart

Association Functional Classifications, as well as information about comorbidities. The patient may undergo pre-screening for adequacy of cardiac signals as captured by the SICD, as indicated at **952**. Step **952** may, for example, use tools, metrics and methods discussed in U.S. Pat. No. 8,079,959, titled PATIENT SCREENING TOOLS FOR IMPLANTABLE CARDIAC STIMULUS SYSTEMS, and/or U.S. patent application Ser. No. 15/001,976, titled AUTOMATED SCREENING METHODS AND APPARATUSES FOR IMPLANTABLE MEDICAL DEVICES, the disclosures of which are incorporated herein by reference. For example, the size and/or consistency of the R-wave and/or the signal to noise ratio of the cardiac signal may be observed, or the ability of an implantable device algorithm to correctly analyze obtained cardiac signals may be determined prior to implantation by applying an algorithm that the device would use once implanted to signals obtained before implantation. A similar process may then be repeated with respect to the P-wave, as indicated at **954**. If both prescreens pass, then the patient may receive a combination of SICD and LCP, as indicated at **956**. If either of the prescreens **952, 954** fail, then the patient may be implanted with a transvenous CRT system as indicated at **958**.

[0138] Other combinations may arise; for example, the patient may pass the SICD screening and could then receive a CRT-P device transvenously, paired with the SICD. In such a system, the CRT-P device and SICD may communicate with one another as desired including in some examples the above methods for using the SICD to assist in determining whether and when the CRT-P would provide pacing therapy in one or more chambers of the heart.

[0139] Following are a number of illustrative examples indicating a manner in which various means may be defined in the context of the present invention.

[0140] A first illustrative example may take the form of an implantable device system comprising a first medical device (**14, 40**) comprising pacing means for delivering a pacing therapy to the heart of a patient, and a second medical device (**16**) comprising sensing means to sense activity of the heart of the patient. The pacing means may comprise a controlling output digital to analog converter (using either voltage or current control) configured to deliver an output current or voltage via output circuitry of an implantable device, such as illustrated with the pulse generator module **104** in FIG. **3**, for coupling to one or several of the electrodes **114, 116**, and/or **118**. The sensing means may comprise processing circuitry including, for example, filtering, amplifying and, as needed, analog-to-digital converting circuitry **52**, coupled via input/output circuitry **58** to one or several electrodes such as electrodes on a canister/housing shown at **64, 66** and/or at **72** on lead **70**, all of which are shown in FIG. **2**.

[0141] Further in the first illustrative example, the first medical device also comprises first communications means for at least receiving communications from at least the second medical device, and the second medical device comprises second communications means for at least issuing communications to at least the first medical device. The first communications means may include amplifying, modulating, demodulating, and/or processing circuitry making up a communications module **102** that may use an antenna and/or electrodes **114, 116** and/or **118** for either radiative or conducted communications, all shown in FIG. **3**. The second communications means may include amplifying, modulating, demodulating and/or processing circuitry making up

communications block 62, that may in turn use one or more of an antenna 74 and/or electrodes 64, 66 and/or 72 for communication, all shown in FIG. 2.

[0142] Further in the first illustrative example, the second medical device comprises atrial event means for using the sensing means to detect an atrial event in the heart of the patient and, in response thereto, to issue a communication to the first medical device. Such atrial event means may take the form of instruction sets stored in memory 54 for operation by a processing block 52 which may include a microcontroller, microprocessor, state machine, or other control, logic and/or processing circuitry, all shown in FIG. 2. The instruction sets for atrial event means may comprise instructions for sensing 602, detecting a trigger 604 and communicating out 606, as shown in FIG. 11, as well as analogous operational blocks of FIGS. 13-17 (here the second medical device in the first illustrative example may operate as "Device 1" in any of FIGS. 11 and 13-17).

[0143] Finally in the first illustrative example, the first medical device comprises therapy means for using the pacing means to deliver therapy to the heart of the patient in response to the communication means receiving the communication issued by the second medical device. The therapy means may take the form of operational instructions for execution by a processing module as shown at 110, operatively coupled to a communications module 102 and the pulse generator module 104, all as shown in FIG. 3. The operational instructions for the therapy means may comprise instructions for receiving a communication 624 and delivering therapy 626 as shown in FIG. 11, as well as analogous operational blocks of FIGS. 13-17 (here the first medical device in the first illustrative example may operate as "Device 2" in any of FIGS. 11 and 13-17).

[0144] A second illustrative example takes the form of a system as in the first illustrative example, wherein the second medical device comprises initialization means for initializing the second medical device atrial event means, including: detection means for detecting at least first and second cardiac cycles of the patient; and window means for establishing a window for detection of the atrial event; wherein the atrial event means is configured to observe cardiac signals of the patient during the window for detection of the atrial event in order to detect the atrial event. In this second illustrative example, the initialization means may take the form of instruction sets stored in memory 54 for operation by a processing block 52 which may include a microcontroller, microprocessor, state machine, or other control, logic and/or processing circuitry, in which instructions the processing block 52 may control and/or access I/O block 58 to use system electrodes 64, 66 and/or 72, all shown in FIG. 2. Such instructions for the initialization means may operate to execute as shown in FIG. 9, using detection means instructions that operate as shown by one or both of 454 and 460 to obtain data as indicated at 562, and then setting parameters including, for example, a window for P-wave detection as indicated at 484. FIGS. 10A-10B show additional versions of the initialization means instruction sets, including obtaining data and setting brady/CRT sensing parameters 504 and/or atrial sensing parameters 514. FIGS. 5A, 5C and 5D each show illustrative approaches to the use of such windows 176 (FIG. 5A), 230 (FIG. 5C), and 242 (FIG. 5D).

[0145] In additional sub-examples related to the second illustrative example, the detection means may be configured

to calculate a composite cardiac cycle data set using the at least first and second cardiac cycles; and the window means may be configured to establish the window for detection of the atrial event using the composite cardiac cycle data set, such as illustrated at 460, 462, 464 in FIG. 9. In yet another sub-example, the window means is configured to set timing information for the window for detection using at least one of the following factors: a feature of a ventricular event detected by the sensing means; or occurrence of a therapy output by the first medical device; FIG. 7 illustratively shows the use of ventricular event (R-wave 312) as such a fiducial. Again, these sub-examples may be embodied in operational instructions for operation by a processing block 52 and associated circuitry including I/O block 58 in FIG. 2.

[0146] In a third illustrative example, the initialization means of the second illustrative example comprises event characterizing means for determining characteristics of the atrial event, the characteristics comprising at least one of: an amplitude; a relative amplitude as compared to one or more preceding ventricular events; a relative amplitude as compared to a mean amplitude during a cardiac cycle; or a maximum or minimum slope; wherein the atrial event means is configured to use determined characteristics of the atrial event in order to detect the atrial event. Such features 486 (FIG. 9) may be selected and used according to operational instructions for operation by a processing block 52 (FIG. 2), to execute a method as illustrated in at least FIG. 9.

[0147] In another illustrative example, the atrial event means of the first or second illustrative examples comprises comparison means to determine whether a signal captured during the window for detection of the atrial event matches a stored atrial event template or a dynamic atrial event template and conclude whether an atrial event occurs in the window for detection using results of the comparison. Such comparison means may be embodied in a processing block 52 (FIG. 2) configured to execute instructions for performance as shown in FIG. 5D.

[0148] In an illustrative example, the second medical device of any of the first, second or third illustrative examples comprises a plurality of electrodes configured for use in sensing cardiac signals, and the second medical device comprises vector selecting means comprising: ventricular signal vector means configured to analyze signals from a plurality of sensing vectors defined by the plurality of electrodes and select a first sensing configuration for detection of ventricular events; and atrial signal vector means configured to analyze signals from a plurality of sensing vectors defined by the plurality of electrodes and select a second sensing configuration for detection of atrial events. The vector selection means may take the form of instruction sets stored in memory 54 for operation by a processing block 52 which may include a microcontroller, microprocessor, state machine, or other control, logic and/or processing circuitry, controlling switches in the I/O block 58 all shown in FIG. 2, with the instruction sets configured to execute a method as shown in FIG. 10B. Such an example may be designed such that the atrial event means is configured to determine one or more parameters for sensing of atrial events using the second sensing configuration, and/or such that the atrial event means is configured to establish a template for atrial events to use to determine whether a signal captured using the second sensing configuration is an atrial event of a predetermined type.

**[0149]** Any of the first to third illustrative examples may be selectively operable to treat Bradycardia, and/or to improve cardiac synchronization. Moreover, such illustrative examples may be configured to allow the second medical device to indicate using the communication means that it has detected an atrial event, and wherein the therapy means is configured to determine when therapy is to be delivered relative to timing of the atrial event. In addition, in some further examples, the second medical device has second communication means having operational instructions configured to command delivery of therapy by the first medical device at a particular time.

**[0150]** These illustrative examples may include a system wherein the first medical device is a leadless cardiac pacemaker, and the second medical device is an implantable cardiac monitor. Alternatively, these illustrative examples may include a system wherein the first medical device is a leadless cardiac pacemaker, and the second medical device is a subcutaneous implantable defibrillator.

**[0151]** Each of these non-limiting examples can stand on its own, or can be combined in various permutations or combinations with one or more of the other examples.

**[0152]** The above detailed description includes references to the accompanying drawings, which form a part of the detailed description. The drawings show, by way of illustration, specific embodiments in which the invention can be practiced. These embodiments are also referred to herein as “examples.” Such examples can include elements in addition to those shown or described. However, the present inventors also contemplate examples in which only those elements shown or described are provided. Moreover, the present inventors also contemplate examples using any combination or permutation of those elements shown or described (or one or more aspects thereof), either with respect to a particular example (or one or more aspects thereof), or with respect to other examples (or one or more aspects thereof) shown or described herein.

**[0153]** In the event of inconsistent usages between this document and any documents so incorporated by reference, the usage in this document controls.

**[0154]** In this document, the terms “a” or “an” are used, as is common in patent documents, to include one or more than one, independent of any other instances or usages of “at least one” or “one or more.” Moreover, in the following claims, the terms “first,” “second,” and “third,” etc. are used merely as labels, and are not intended to impose a specific order of steps in a process, or any numerical requirements on their objects. Where a specific order of a steps is intended in the claims, the words “before” or “after” will be used.

**[0155]** Method examples described herein can be machine or computer-implemented at least in part. Some examples can include a computer-readable medium or machine-readable medium encoded with instructions operable to configure an electronic device to perform methods as described in the above examples. An implementation of such methods can include code, such as microcode, assembly language code, a higher-level language code, or the like. Such code can include computer readable instructions for performing various methods. The code may form portions of computer program products. Further, in an example, the code can be tangibly stored on one or more volatile, non-transitory, or non-volatile tangible computer-readable media, such as during execution or at other times. Examples of these tangible computer-readable media can include, but are not limited to,

hard disks, removable magnetic or optical disks, magnetic cassettes, memory cards or sticks, random access memories (RAMs), read only memories (ROMs), and the like.

**[0156]** The above description is intended to be illustrative, and not restrictive. For example, the above-described examples (or one or more aspects thereof) may be used in combination with each other. Other embodiments can be used, such as by one of ordinary skill in the art upon reviewing the above description.

**[0157]** The Abstract is provided to comply with 37 C.F.R. § 1.72(b), to allow the reader to quickly ascertain the nature of the technical disclosure. It is submitted with the understanding that it will not be used to interpret or limit the scope or meaning of the claims.

**[0158]** Also, in the above Detailed Description, various features may be grouped together to streamline the disclosure. This should not be interpreted as intending that an unclaimed disclosed feature is essential to any claim. Rather, inventive subject matter may lie in less than all features of a particular disclosed embodiment. Thus, the following claims are hereby incorporated into the Detailed Description as examples or embodiments, with each claim standing on its own as a separate embodiment, and it is contemplated that such embodiments can be combined with each other in various combinations or permutations. The scope of the invention should be determined with reference to the appended claims, along with the full scope of equivalents to which such claims are entitled.

The claimed invention is:

1. An implantable medical device comprising:

- a lead comprising a plurality of implantable electrodes including at least first and second sensing electrodes;
- a housing containing operational circuitry for analyzing signals captured using the plurality of implantable electrodes, the housing also including at least one electrode, the operational further comprising communication circuitry configured to communicate to a second implantable medical device;

wherein the operational circuitry is configured to perform a sensing vector selection routine in which:

the operational circuitry performs a first analysis of signals from a plurality of sensing vectors defined by the plurality of electrodes and selects a first sensing configuration having a first sensing vector from the plurality of sensing vectors for detection of ventricular events; and

the operational circuitry performs a second analysis of signals from the plurality of sensing vectors defined by the plurality of electrodes and selects a second sensing configuration having a second sensing vector from the plurality of sensing vectors for detection of atrial events; and

further wherein:

the operational circuitry is configured to use the second sensing configuration to determine whether an atrial event is detected; and

in response to determining that an atrial event has been detected, the operational circuitry is configured to communicate to the second medical device.

2. The implantable medical device of claim 1 wherein the operational circuitry is configured to determine an atrial sensing window for detection of atrial events and is configured to selectively use the second sensing configuration to determine whether an atrial event takes place in the atrial

sensing window, wherein the operational circuitry is configured to define the atrial sensing window in relationship to a ventricular sensed event sensed identified using the first sensing configuration.

3. The implantable medical device of claim 1 wherein the operational circuitry is configured to determine an atrial sensing window for detection of atrial events and is configured to selectively use the second sensing configuration to determine whether an atrial event takes place in the atrial sensing window, wherein the operational circuitry is configured to define the atrial sensing window in relationship to a detected therapy output generated by the second medical device.

4. The implantable medical device of claim 1 wherein the operational circuitry further comprises therapy delivery circuitry to issue electrical cardiac therapy, and the operational circuitry is configured to use the first sensing configuration to sense ventricular arrhythmia, and if a ventricular arrhythmia is detected, to use the therapy delivery circuitry to issue a therapy for ventricular arrhythmia.

5. The implantable medical device of claim 1 wherein the operational circuitry is configured to use the first sensing configuration to sense ventricular arrhythmia, and if a ventricular arrhythmia is detected, to issue a communication to the second medical device to treat ventricular arrhythmia.

6. The implantable medical device of claim 1 wherein the operational circuitry is configured to use the second sensing configuration to sense events to support bradycardia therapy.

7. The implantable medical device of claim 1 wherein the operational circuitry is configured to use the second sensing configuration to sense events to support resynchronization therapy.

8. An implantable medical device comprising:

a housing having a plurality of implantable electrodes thereon and containing operational circuitry for analyzing signals captured using the plurality of implantable electrodes, the operational further comprising communication circuitry configured to communicate to a second implantable medical device;

wherein the operational circuitry is configured to perform a sensing vector selection routine in which:

the operational circuitry performs a first analysis of signals from a plurality of sensing vectors defined by the plurality of electrodes and selects a first sensing configuration having a first sensing vector from the plurality of sensing vectors for detection of ventricular events; and

the operational circuitry performs a second analysis of signals from the plurality of sensing vectors defined by the plurality of electrodes and selects a second sensing configuration having a second sensing vector from the plurality of sensing vectors for detection of atrial events; and

further wherein:

the operational circuitry is configured to use the second sensing configuration to determine whether an atrial event is detected; and

in response to determining that an atrial event has been detected, the operational circuitry is configured to communicate to the second medical device.

9. The implantable medical device of claim 8 wherein the operational circuitry is configured to determine an atrial sensing window for detection of atrial events and is configured to selectively use the second sensing configuration to

determine whether an atrial event takes place in the atrial sensing window, wherein the operational circuitry is configured to define the atrial sensing window in relationship to a ventricular sensed event sensed identified using the first sensing configuration.

10. The implantable medical device of claim 8 wherein the operational circuitry is configured to determine an atrial sensing window for detection of atrial events and is configured to selectively use the second sensing configuration to determine whether an atrial event takes place in the atrial sensing window, wherein the operational circuitry is configured to define the atrial sensing window in relationship to a detected therapy output generated by the second medical device.

11. The implantable medical device of claim 8 wherein the operational circuitry is configured to use the first sensing configuration to sense ventricular arrhythmia, and if a ventricular arrhythmia is detected, to issue a communication to the second medical device to treat ventricular arrhythmia.

12. The implantable medical device of claim 8 wherein the operational circuitry is configured to use the second sensing configuration to sense events to support bradycardia therapy.

13. The implantable medical device of claim 8 wherein the operational circuitry is configured to use the second sensing configuration to sense events to support resynchronization therapy.

14. An implantable medical device comprising:

a housing containing operational circuitry for analyzing cardiac signals and communication circuitry configured to communicate to a second implantable medical device;

a plurality of electrodes coupled to the operational circuitry to provide cardiac signals thereto, the plurality of electrodes including at least one electrode on the housing and at least two additional electrodes that are disposed on the housing or on a lead;

wherein the operational circuitry is configured to perform a sensing configuration routine in which:

the operational circuitry performs a first analysis of signals from the plurality of electrodes and selects a first sensing configuration for detection of ventricular events; and

the operational circuitry performs a second analysis of signals from the plurality of electrodes and selects a second sensing configuration for detection of atrial events; and

further wherein:

the operational circuitry is configured to use the second sensing configuration to determine whether an atrial event is detected; and

in response to determining that an atrial event has been detected, the operational circuitry is configured to communicate to the second medical device.

15. The implantable medical device of claim 14 wherein the operational circuitry is configured to determine an atrial sensing window for detection of atrial events and is configured to selectively use the second sensing configuration to determine whether an atrial event takes place in the atrial sensing window, wherein the operational circuitry is configured to define the atrial sensing window in relationship to a ventricular sensed event sensed identified using the first sensing configuration.

16. The implantable medical device of claim 14 wherein the operational circuitry is configured to determine an atrial sensing window for detection of atrial events and is configured to selectively use the second sensing configuration to determine whether an atrial event takes place in the atrial sensing window, wherein the operational circuitry is configured to define the atrial sensing window in relationship to a detected therapy output generated by the second medical device.

17. The implantable medical device of claim 14 wherein the operational circuitry is configured to use the first sensing configuration to sense ventricular arrhythmia, and if a ventricular arrhythmia is detected, to issue a communication to the second medical device to treat ventricular arrhythmia.

18. The implantable medical device of claim 14 wherein the operational circuitry is configured to use the first sensing configuration to sense ventricular arrhythmia, and if a ventricular arrhythmia is detected, to treat the ventricular arrhythmia.

19. The implantable medical device of claim 14 wherein the operational circuitry is configured to use the second sensing configuration to sense events to support bradycardia therapy.

20. The implantable medical device of claim 14 wherein the operational circuitry is configured to use the second sensing configuration to sense events to support resynchronization therapy.

\* \* \* \* \*

专利名称(译)	皮下感应p波的心脏治疗系统用于重新同步起搏管理		
公开(公告)号	<a href="#">US20200094063A1</a>	公开(公告)日	2020-03-26
申请号	US16/681103	申请日	2019-11-12
[标]申请(专利权)人(译)	心脏起搏器股份公司		
申请(专利权)人(译)	心脏起搏器, INC.		
当前申请(专利权)人(译)	心脏起搏器, INC.		
[标]发明人	HAHN STEPHEN J SIEJKO KRZYSZTOF Z LINDER WILLIAM J MAILE KEITH R BRISBEN AMY JEAN HERRMANN KEITH L KOOP BRENDAN E HAASL BENJAMIN J		
发明人	HAHN, STEPHEN J. SIEJKO, KRZYSZTOF Z. LINDER, WILLIAM J. MAILE, KEITH R. BRISBEN, AMY JEAN HERRMANN, KEITH L. KOOP, BRENDAN E. HAASL, BENJAMIN J.		
IPC分类号	A61N1/372 A61N1/365 A61B5/0452 A61B5/00 A61N1/375 A61N1/39		
CPC分类号	A61N1/3756 A61B5/0456 A61B5/0452 A61N1/36514 A61N1/3627 A61N1/37288 A61B5/726 A61B5/0031 A61N1/365 A61B5/686 A61N1/3925 A61N1/3684 A61B5/4836 A61N1/3962 A61N1/3956 A61B5/0464 A61N1/36507 A61B5/0006		
优先权	62/355121 2016-06-27 US		
外部链接	<a href="#">Espacenet</a> <a href="#">USPTO</a>		

摘要(译)

被配置为提供心脏再同步治疗和/或心动过缓起搏治疗的系统，方法和可植入设备。位于患者心脏的第一设备被配置为从第二设备接收通信并响应于接收到的通信或根据接收到的通信来进行起搏治疗。位于其他位置的第二设备配置为确定发生了房性事件，并与第一设备进行通信以触发起搏治疗。第二设备可以被配置为通过使用矢量选择和心房事件加窗以及其他增强来感测心房事件。讨论和处理异常情况。

