



(19) **United States**

(12) **Patent Application Publication**

**Felix et al.**

(10) **Pub. No.: US 2019/0380615 A1**

(43) **Pub. Date: Dec. 19, 2019**

(54) **SELF-AUTHENTICATING ELECTROCARDIOGRAPHY AND PHYSIOLOGICAL SENSOR MONITOR**

**Publication Classification**

(71) Applicant: **Bardy Diagnostics, Inc.**, Seattle, WA (US)

(51) **Int. Cl.**  
*A61B 5/0408* (2006.01)  
*A61B 5/00* (2006.01)  
*A61B 5/0432* (2006.01)  
*A61B 5/0402* (2006.01)

(72) Inventors: **Jason Felix**, Vashon Island, WA (US);  
**Gust H. Bardy**, Carnation, WA (US);  
**Jon Mikalson Bishay**, Lexington, KY (US)

(52) **U.S. Cl.**  
CPC ..... *A61B 5/04087* (2013.01); *A61B 5/0006* (2013.01); *A61B 5/0022* (2013.01); *A61B 2562/08* (2013.01); *A61B 5/04325* (2013.01); *A61B 5/6823* (2013.01); *A61B 5/0402* (2013.01); *A61B 5/04085* (2013.01)

(21) Appl. No.: **16/558,231**

(22) Filed: **Sep. 2, 2019**

(57) **ABSTRACT**

**Related U.S. Application Data**

(63) Continuation of application No. 15/602,007, filed on May 22, 2017, now Pat. No. 10,398,334, which is a continuation of application No. 14/082,066, filed on Nov. 15, 2013, now Pat. No. 9,655,538, which is a continuation-in-part of application No. 14/080,717, filed on Nov. 14, 2013, now Pat. No. 9,545,204, said application No. 14/082,066 is a continuation-in-part of application No. 14/080,725, filed on Nov. 14, 2013, now Pat. No. 9,730,593.

(60) Provisional application No. 61/882,403, filed on Sep. 25, 2013, provisional application No. 61/882,403, filed on Sep. 25, 2013.

A self-authenticating electrocardiography and physiological sensor monitor is provided. An electrode patch includes an elongated strip and electrodes exposed on each end. A receptacle is adhered to the elongated strip and includes electrical pads. Circuit traces are electrically coupled to the electrocardiographic electrodes and the electrical pads. A monitor recorder having a sealed housing is adapted to be secured into the receptacle. Circuitry within the housing includes a microcontroller with a private key. A copy of the private key is stored on the patch. Self-authentication is performed each time the monitor recorder is inserted into a new patch by challenging the patch using a code hashed with the private key and by receiving a response from the patch in reply to the challenge. A front end circuit senses electrocardiographic signals via electrodes on the patch when the response received by the microcontroller is positive, until the electrode patch expires.

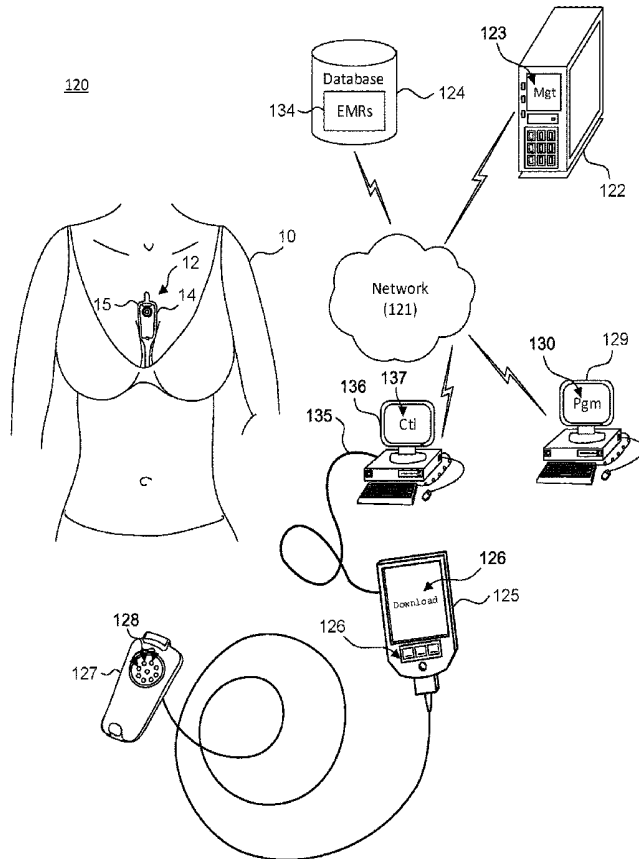

**Fig. 1.**

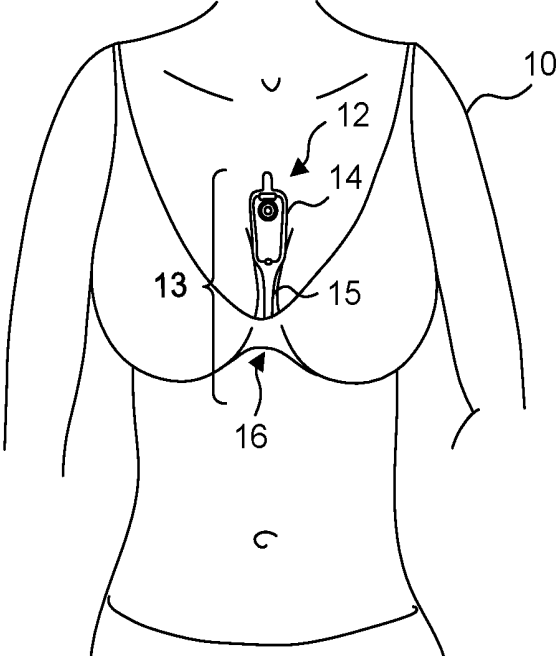

**Fig. 2.**

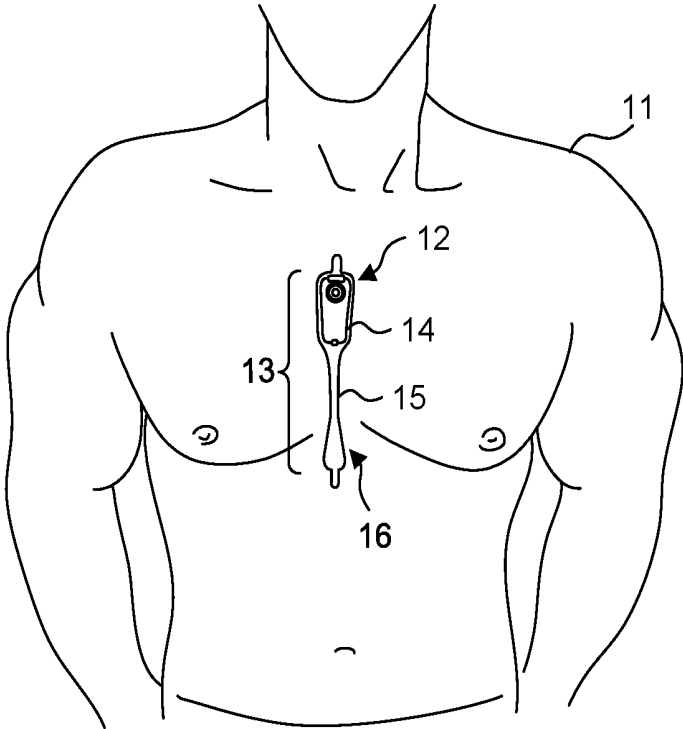

**Fig. 3.**

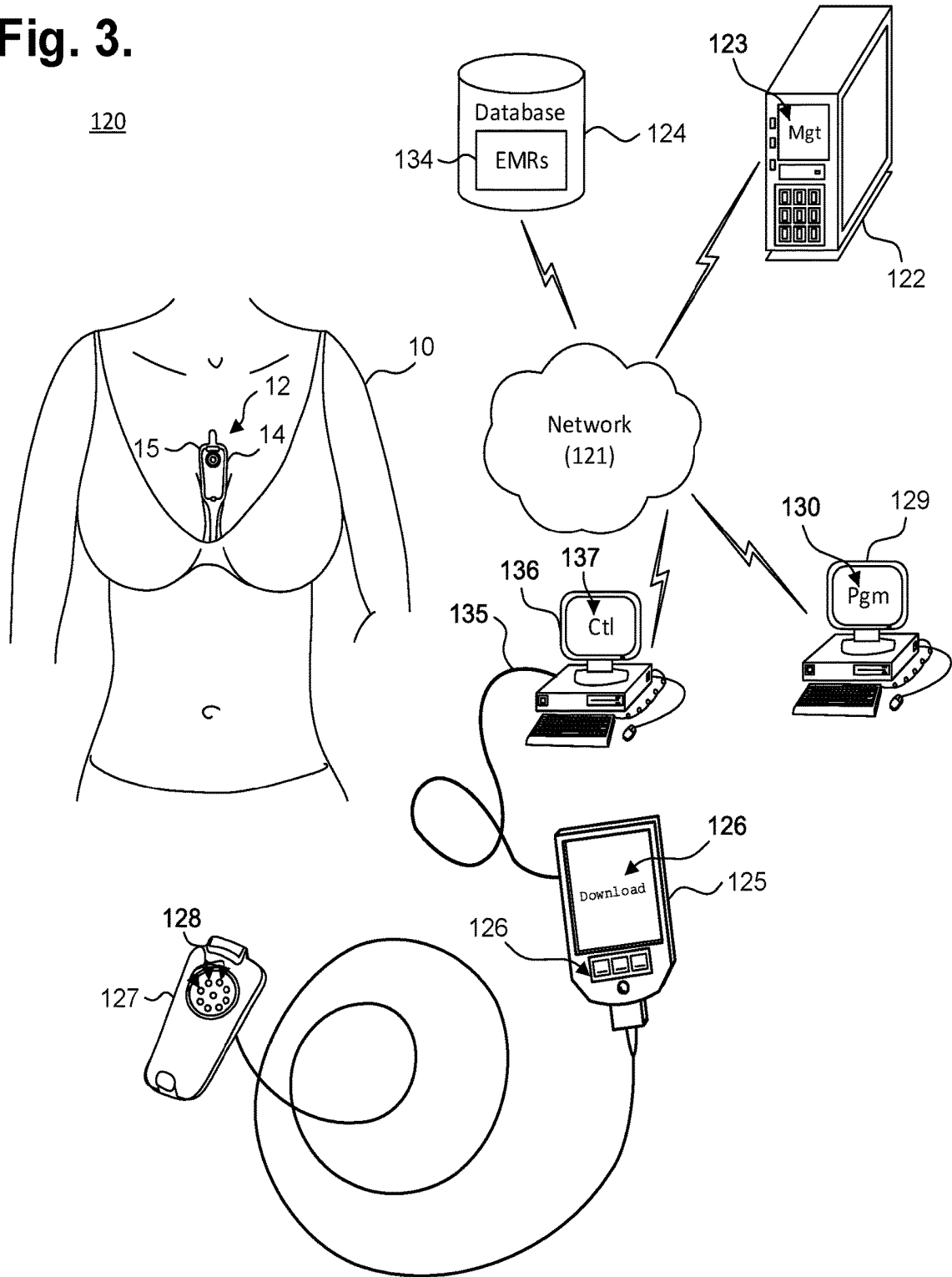

**Fig. 4.**

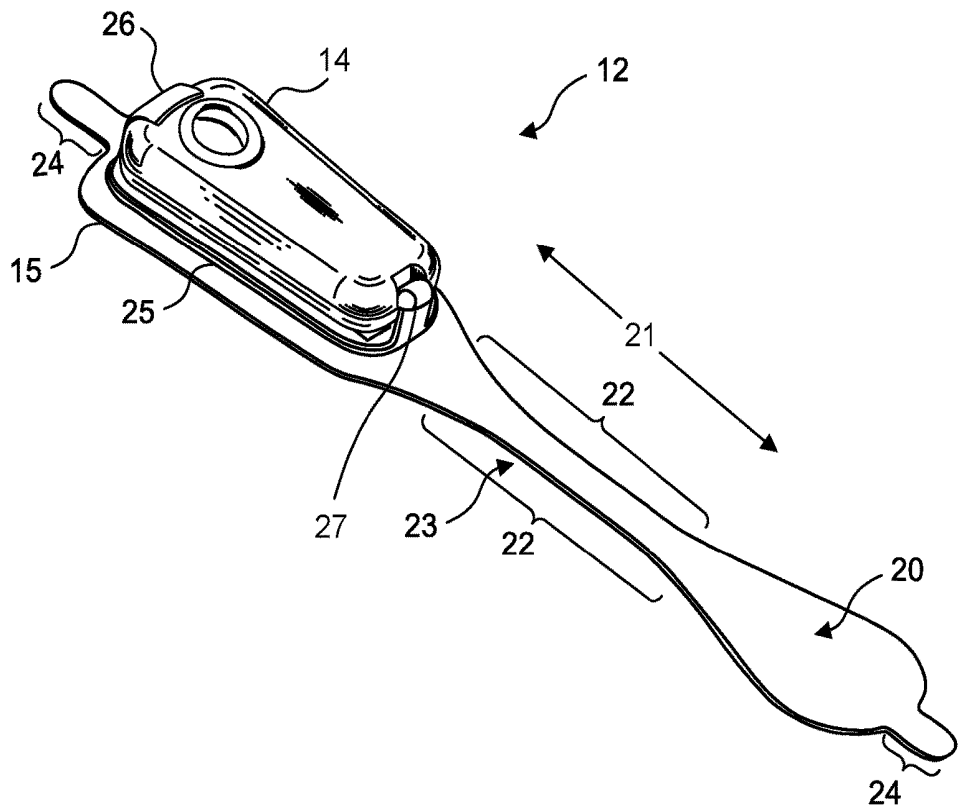

**Fig. 5.**

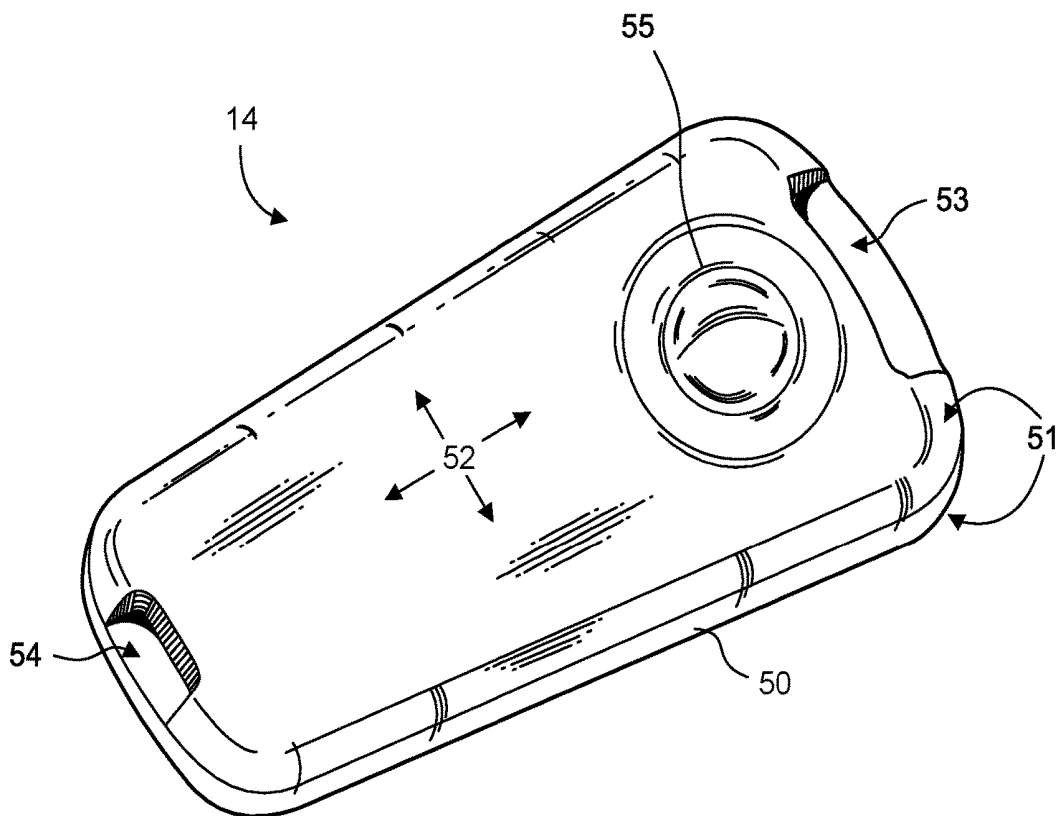

**Fig. 6.**

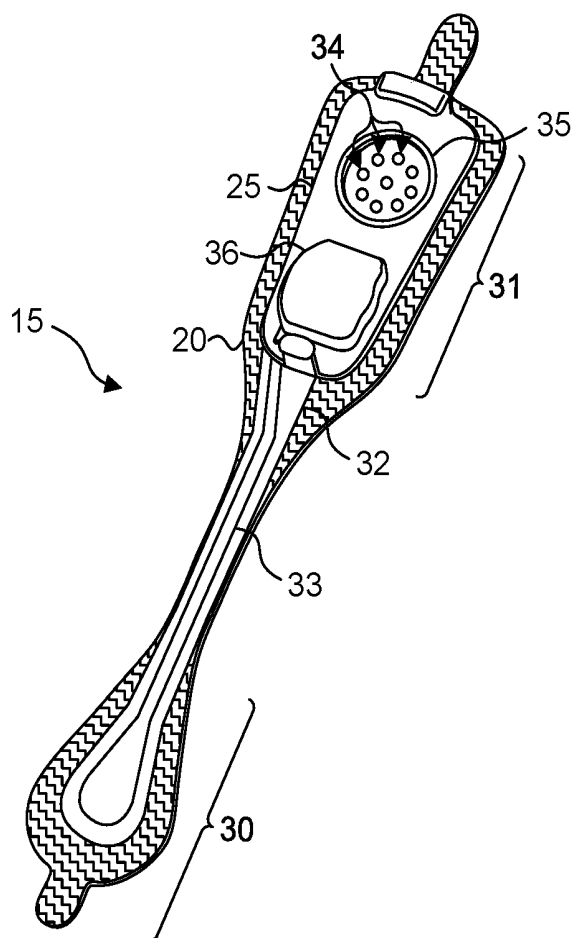

**Fig. 7.**

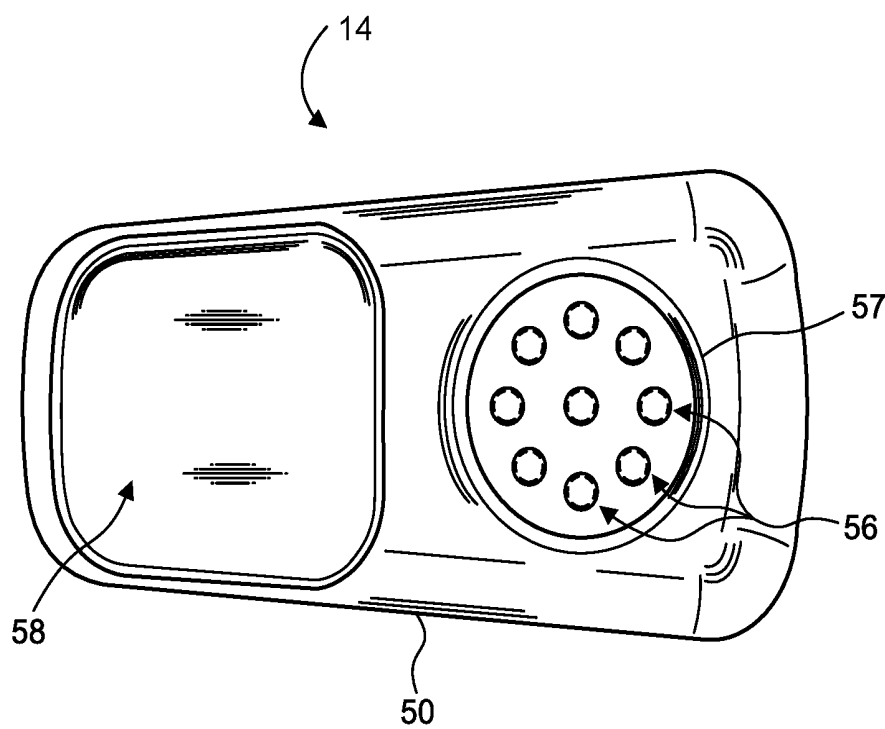

**Fig. 8.**

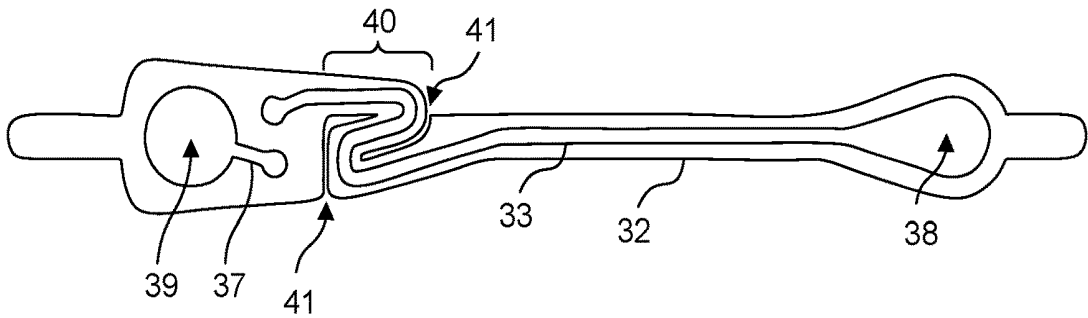

**Fig. 9.**

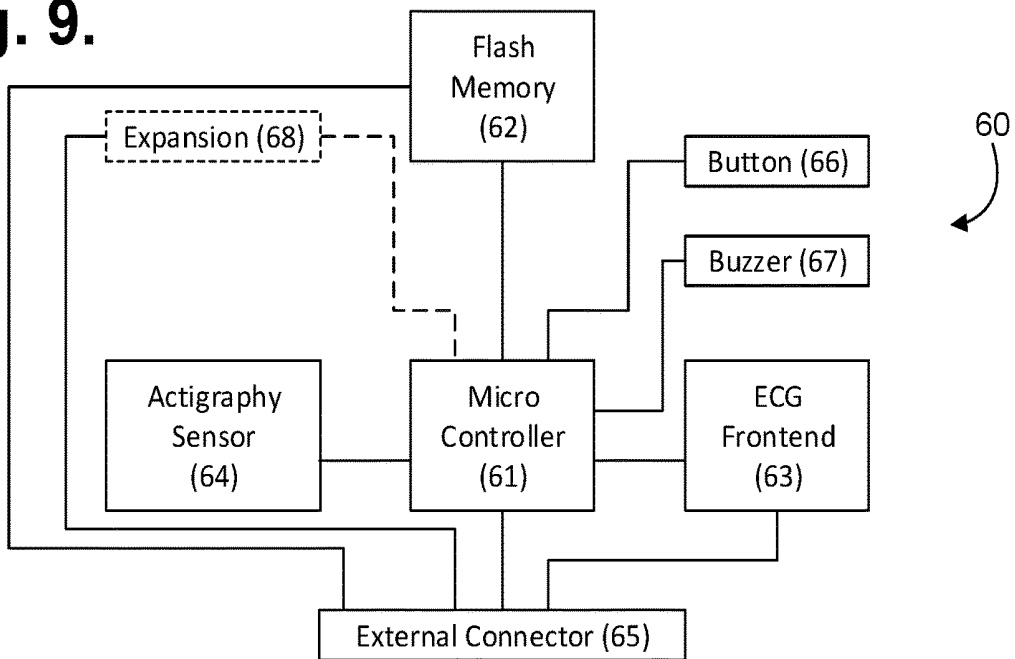

**Fig. 10.**

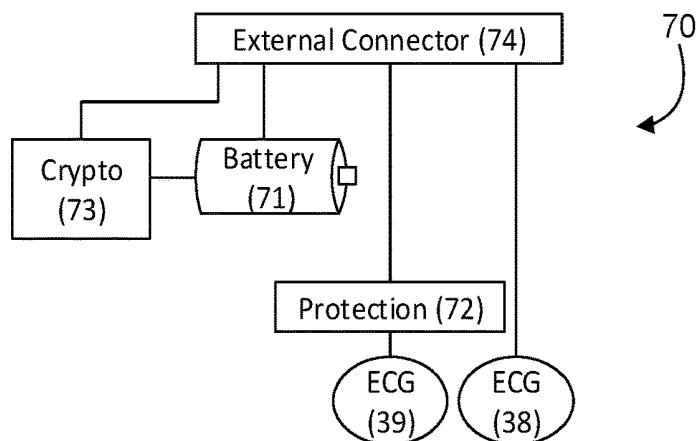

**Fig. 11.**

100

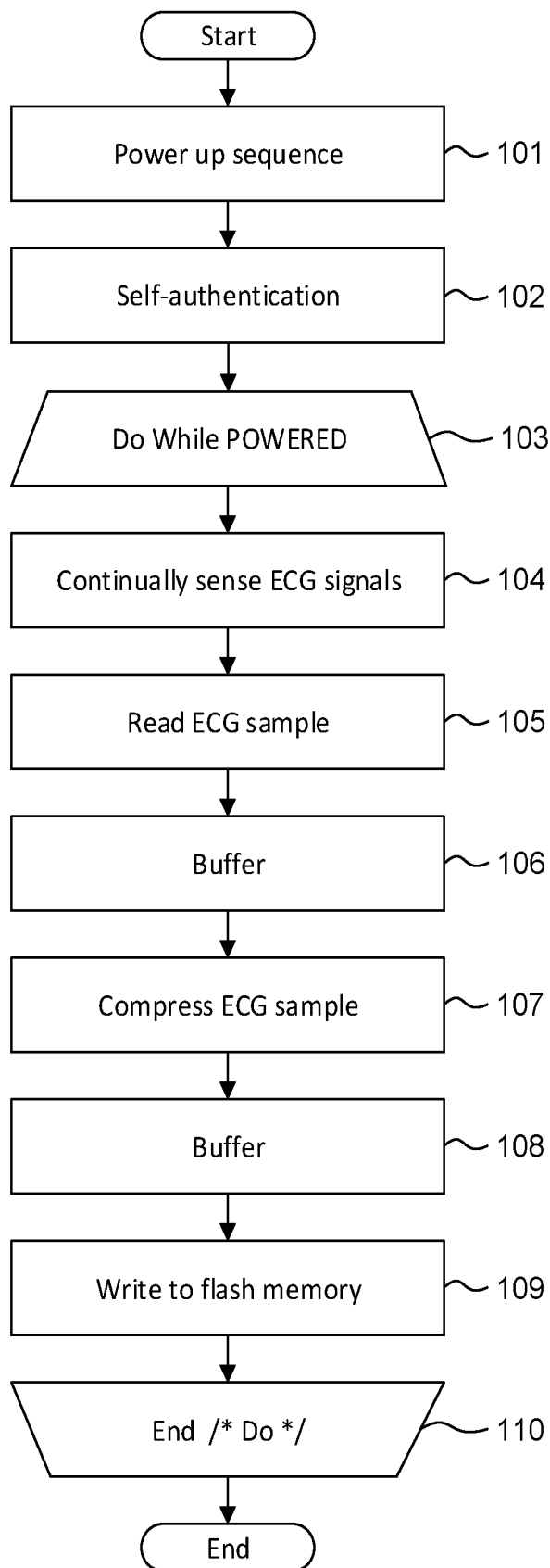
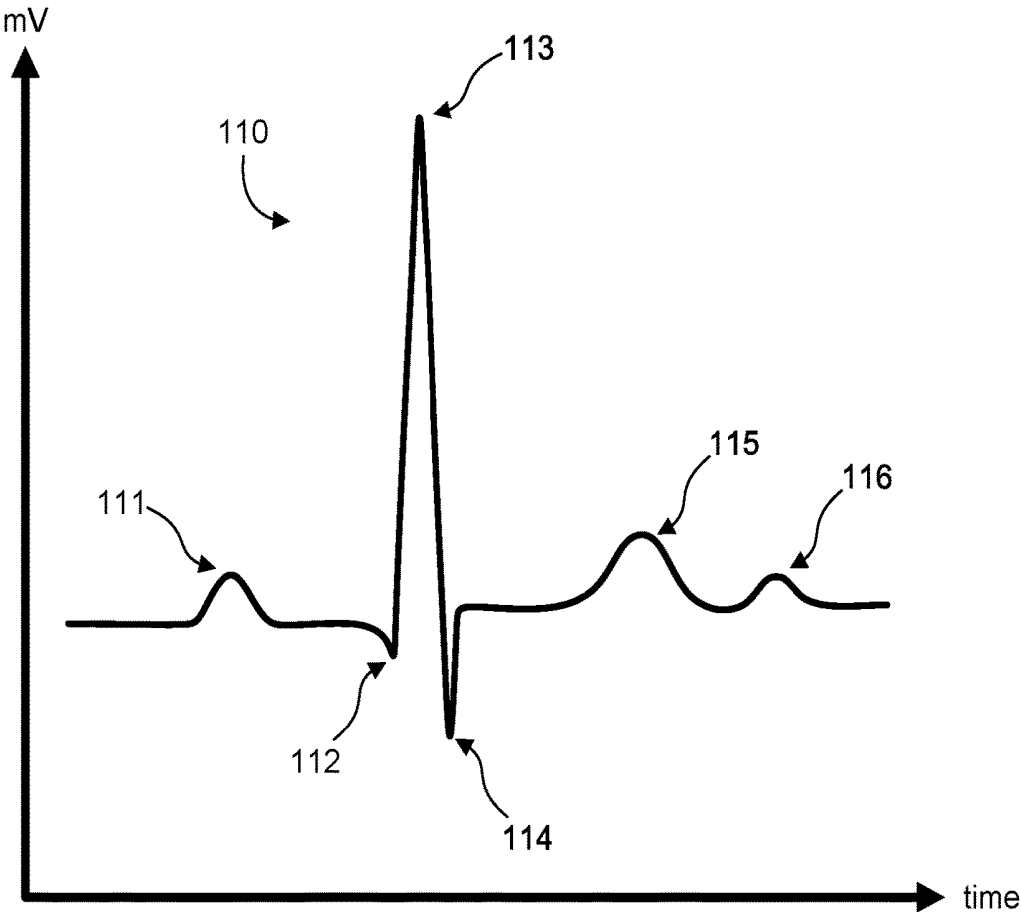
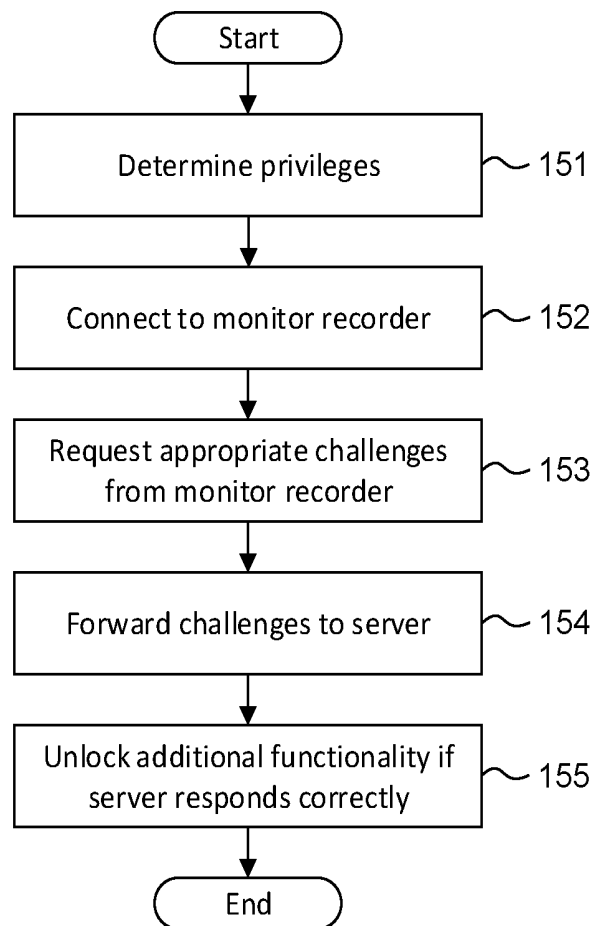

Fig. 12.



**Fig. 13.**150

## SELF-AUTHENTICATING ELECTROCARDIOGRAPHY AND PHYSIOLOGICAL SENSOR MONITOR

### CROSS-REFERENCE TO RELATED APPLICATION

[0001] This non-provisional patent application is a continuation of U.S. patent application Ser. No. 15/602,007, filed May 22, 2017, pending, which is a continuation of U.S. Pat. No. 9,655,538, issued May 23, 2017, which is a continuation-in-part of U.S. Pat. No. 9,545,204, issued Jan. 17, 2017, and is a continuation-in-part of U.S. Pat. No. 9,730,593, issued Aug. 15, 2017, and further claims priority under 35 U.S.C. § 119(e) to U.S. Provisional Patent application, Ser. No. 61/882,403, filed Sep. 25, 2013, the disclosures of which are incorporated by reference.

### FIELD

[0002] This application relates in general to electrocardiographic monitoring and, in particular, to a self-authenticating electrocardiography and physiological sensor monitor.

### BACKGROUND

[0003] The heart emits electrical signals as a by-product of the propagation of the action potentials that trigger depolarization of heart fibers. An electrocardiogram (ECG) measures and records such electrical potentials to visually depict the electrical activity of the heart over time. Conventionally, a standardized set format 12-lead configuration is used by an ECG machine to record cardiac electrical signals from well-established traditional chest locations. Electrodes at the end of each lead are placed on the skin over the anterior thoracic region of the patient's body to the lower right and to the lower left of the sternum, on the left anterior chest, and on the limbs. Sensed cardiac electrical activity is represented by PQRSTU waveforms that can be interpreted post-ECG recordation to derive heart rate and physiology. The P-wave represents atrial electrical activity. The QRSTU components represent ventricular electrical activity.

[0004] An ECG is a tool used by physicians to diagnose heart problems and other potential health concerns. An ECG is a snapshot of heart function, typically recorded over 12 seconds, that can help diagnose rate and regularity of heartbeats, effect of drugs or cardiac devices, including pacemakers and implantable cardioverter-defibrillators (ICDs), and whether a patient has heart disease. ECGs are used in-clinic during appointments, and, as a result, are limited to recording only those heart-related aspects present at the time of recording. Sporadic conditions that may not show up during a spot ECG recording require other means to diagnose them. These disorders include fainting or syncope; rhythm disorders, such as tachyarrhythmias and bradyarrhythmias; apneic episodes; and other cardiac and related disorders. Thus, an ECG only provides a partial picture and can be insufficient for complete patient diagnosis of many cardiac disorders.

[0005] Diagnostic efficacy can be improved, when appropriate, through the use of long-term extended ECG monitoring. Recording sufficient ECG and related physiology over an extended period is challenging, and often essential to enabling a physician to identify events of potential concern. A 30-day observation period is considered the "gold standard" of ECG monitoring, yet achieving a 30-day

observation day period has proven unworkable because such ECG monitoring systems are arduous to employ, cumbersome to the patient, and excessively costly. Ambulatory monitoring in-clinic is implausible and impracticable. Nevertheless, if a patient's ECG could be recorded in an ambulatory setting, thereby allowing the patient to engage in activities of daily living, the chances of acquiring meaningful information and capturing an abnormal event while the patient is engaged in normal activities becomes more likely to be achieved.

[0006] For instance, the long-term wear of ECG electrodes is complicated by skin irritation and the inability ECG electrodes to maintain continual skin contact after a day or two. Moreover, time, dirt, moisture, and other environmental contaminants, as well as perspiration, skin oil, and dead skin cells from the patient's body, can get between an ECG electrode, the non-conductive adhesive used to adhere the ECG electrode, and the skin's surface. All of these factors adversely affect electrode adhesion and the quality of cardiac signal recordings. Furthermore, the physical movements of the patient and their clothing impart various compressional, tensile, and torsional forces on the contact point of an ECG electrode, especially over long recording times, and an inflexibly fastened ECG electrode will be prone to becoming dislodged. Notwithstanding the cause of electrode dislodgment, depending upon the type of ECG monitor employed, precise re-placement of a dislodged ECG electrode maybe essential to ensuring signal capture at the same fidelity. Moreover, dislodgment may occur unbeknownst to the patient, making the ECG recordings worthless. Further, some patients may have skin that is susceptible to itching or irritation, and the wearing of ECG electrodes can aggravate such skin conditions. Thus, a patient may want or need to periodically remove or replace ECG electrodes during a long-term ECG monitoring period, whether to replace a dislodged electrode, reestablish better adhesion, alleviate itching or irritation, allow for cleansing of the skin, allow for showering and exercise, or for other purpose. Such replacement or slight alteration in electrode location actually facilitates the goal of recording the ECG signal for long periods of time; however, ensuring that the level of quality of ECG recording and patient service remains constant over an extended period of time is dependent upon the monitoring equipment being up to a known standard. Use of third party consumables, such as ECG electrodes, could undermine expectations of ECG recording fidelity and adversely skew monitoring results.

[0007] Conventionally, Holter monitors are widely used for long-term extended ECG monitoring. Typically, they are used for only 24-48 hours. A typical Holter monitor is a wearable and portable version of an ECG that include cables for each electrode placed on the skin and a separate battery-powered ECG recorder. The cable and electrode combination (or leads) are placed in the anterior thoracic region in a manner similar to what is done with an in-clinic standard ECG machine. The duration of a Holter monitoring recording depends on the sensing and storage capabilities of the monitor, as well as battery life. A "looping" Holter monitor (or event) can operate for a longer period of time by overwriting older ECG tracings, thence "recycling" storage in favor of extended operation, yet at the risk of losing event data. Although capable of extended ECG monitoring, Holter monitors are cumbersome, expensive and typically only available by medical prescription, which limits their usability.

ity. Further, the skill required to properly place the electrodes on the patient's chest hinders or precludes a patient from replacing or removing the precordial leads and usually involves moving the patient from the physician office to a specialized center within the hospital or clinic.

**[0008]** The ZIO XT Patch and ZIO Event Card devices, manufactured by iRhythm Tech., Inc., San Francisco, Calif., are wearable stick-on monitoring devices that are typically worn on the upper left pectoral region to respectively provide continuous and looping ECG recording. The location is used to simulate surgically implanted monitors. Both of these devices are prescription-only and for single patient use. The ZIO XT Patch device is limited to a 14-day monitoring period, while the electrodes only of the ZIO Event Card device can be worn for up to 30 days. The ZIO XT Patch device combines both electronic recordation components, including battery, and physical electrodes into a unitary assembly that adheres to the patient's skin. The ZIO XT Patch device uses adhesive sufficiently strong to support the weight of both the monitor and the electrodes over an extended period of time and to resist disadherence from the patient's body, albeit at the cost of disallowing removal or relocation during the monitoring period. Moreover, throughout monitoring, the battery is continually depleted and battery capacity can potentially limit overall monitoring duration. The ZIO Event Card device is a form of downsized Holter monitor with a recorder component that must be removed temporarily during baths or other activities that could damage the non-waterproof electronics. Both devices represent compromises between length of wear and quality of ECG monitoring, especially with respect to ease of long term use, female-friendly fit, and quality of atrial (P-wave) signals. Moreover, both devices rely on the same set of ECG electrodes for the duration of the monitoring period; signal capture can suffer as the ECG electrodes disadhere from the patient's body over time.

**[0009]** Therefore, a need remains for an extended wear continuously recording ECG monitor practicably capable of being worn for a long period of time in both men and women and capable of recording atrial signals reliably with quality assurance implemented as part of disposable component replenishment.

**[0010]** A further need remains for a device capable of recording signals ideal for arrhythmia discrimination, especially a device designed for atrial activity recording.

#### SUMMARY

**[0011]** Physiological monitoring can be provided through a wearable monitor that includes two components, a flexible extended wear electrode patch and a removable reusable monitor recorder. The wearable monitor sits centrally (in the midline) on the patient's chest along the sternum oriented top-to-bottom. The placement of the wearable monitor in a location at the sternal midline (or immediately to either side of the sternum), with its unique narrow "hourglass"-like shape, benefits long-term extended wear by removing the requirement that ECG electrodes be continually placed in the same spots on the skin throughout the monitoring period. Instead, the patient is free to place an electrode patch anywhere within the general region of the sternum, the area most likely to record high quality atrial signals or P-waves. In addition, ensuring that the level of quality of ECG recording and patient service remains constant over an extended period of time is provided through self-authenti-

cation of electrode patches (and other accessories). The monitor recorder implements a challenge response scheme upon being connected to an electrode patch (or other accessory). Failing self-authentication, the monitor recorder signals an error condition. In addition, electrode patches (and other accessories) can be limited to operating for only a certain period of time, or with pre-defined operational parameters or privileges. In a further embodiment, a patient can purchase additional time, pre-defined operational parameters or privileges through a server-based subscription service.

**[0012]** One embodiment provides an electrocardiography and physiological sensor monitor recorder with a self-authenticating electrocardiography monitoring circuit. A sealed housing is adapted to be removably secured on an electrode patch and electronic circuitry is included within the housing. The electronic circuitry includes a microcontroller with a private key or precomputed digest. A copy of the private key or precomputed digest is stored on the electrode patch. Self-authentication with the electrode patch is performed each time the housing is inserted into a new electrode patch by challenging the electrode patch using a code hashed with the private key or precomputed digest and by receiving a response from the electrode patch in reply to the challenge. An electrocardiographic front end circuit is electrically interfaced to the microcontroller to sense electrocardiographic signals via electrodes on the electrode patch when the response received by the microcontroller is positive and to continue to sense the electrocardiographic signals until the electrode patch expires.

**[0013]** A further embodiment provides a self-authenticating electrocardiography and physiological sensor monitor. An electrode patch includes an elongated strip of material and electrocardiographic electrodes exposed on each end of the elongated strip. A receptacle is adhered to a surface of the elongated strip and includes electrical pads. A circuit is affixed on each end of the elongated strip and includes circuit traces electrically coupled to the electrocardiographic electrodes and the electrical pads. An electrocardiography monitor recorder having a sealed housing is adapted to be secured into the non-conductive receptacle. Electronic circuitry included within the housing includes a microcontroller with a private key or precomputed digest. A copy of the private key or precomputed digest is stored on the electrode patch. Self-authentication with the electrode patch is performed each time the monitor recorder is inserted into a new electrode patch by challenging the electrode patch using a code hashed with the private key or precomputed digest and by receiving a response from the electrode patch in reply to the challenge. An electrocardiographic front end circuit is electrically interfaced to the microcontroller to sense electrocardiographic signals via electrodes on the electrode patch when the response received by the microcontroller is positive and to continue to sense the electrocardiographic signals until the electrode patch expires.

**[0014]** The monitoring patch is especially suited to the female anatomy. The narrow longitudinal midsection can fit nicely within the intermammary cleft of the breasts without inducing discomfort, whereas conventional patch electrodes are wide and, if adhered between the breasts, would cause chafing, irritation, frustration, and annoyance, leading to low patient compliance.

[0015] The foregoing aspects enhance ECG monitoring performance and quality, facilitating long-term ECG recording, critical to accurate arrhythmia diagnosis.

[0016] In addition, the foregoing aspects enhance comfort in women (and certain men), but not irritation of the breasts, by placing the monitoring patch in the best location possible for optimizing the recording of cardiac signals from the atrium, another feature critical to proper arrhythmia diagnosis.

[0017] Finally, the foregoing aspects as relevant to monitoring are equally applicable to recording other physiological measures, such as temperature, respiratory rate, blood sugar, oxygen saturation, and blood pressure, as well as other measures of body chemistry and physiology.

[0018] Still other embodiments will become readily apparent to those skilled in the art from the following detailed description, wherein are described embodiments by way of illustrating the best mode contemplated. As will be realized, other and different embodiments are possible and the embodiments' several details are capable of modifications in various obvious respects, all without departing from their spirit and the scope. Accordingly, the drawings and detailed description are to be regarded as illustrative in nature and not as restrictive.

#### BRIEF DESCRIPTION OF THE DRAWINGS

[0019] FIGS. 1 and 2 are diagrams showing, by way of examples, an extended wear electrocardiography and physiological sensor monitor respectively fitted to the sternal region of a female patient and a male patient.

[0020] FIG. 3 is a functional block diagram showing a system for providing a self-authenticating electrocardiography monitoring circuit in accordance with one embodiment.

[0021] FIG. 4 is a perspective view showing an extended wear electrode patch with a monitor recorder in accordance with one embodiment inserted.

[0022] FIG. 5 is a perspective view showing the monitor recorder of FIG. 4.

[0023] FIG. 6 is a perspective view showing the extended wear electrode patch of FIG. 4 without a monitor recorder inserted.

[0024] FIG. 7 is a bottom plan view of the monitor recorder of FIG. 4.

[0025] FIG. 8 is a top view showing the flexible circuit of the extended wear electrode patch of FIG. 4 when mounted above the flexible backing.

[0026] FIG. 9 is a functional block diagram showing the component architecture of the circuitry of the monitor recorder of FIG. 4.

[0027] FIG. 10 is a functional block diagram showing the circuitry of the extended wear electrode patch of FIG. 4.

[0028] FIG. 11 is a flow diagram showing a monitor recorder-implemented method for monitoring ECG data for use in the monitor recorder of FIG. 4.

[0029] FIG. 12 is a graph showing, by way of example, a typical ECG waveform.

[0030] FIG. 13 is a flow diagram showing a method for providing a self-authenticating electrocardiography monitoring circuit in accordance with one embodiment.

#### DETAILED DESCRIPTION

[0031] Physiological monitoring can be provided through a wearable monitor that includes two components, a flexible

extended wear electrode patch and a removable reusable monitor recorder. FIGS. 1 and 2 are diagrams showing, by way of examples, an extended wear electrocardiography and physiological sensor monitor 12, including a monitor recorder 14 in accordance with one embodiment, respectively fitted to the sternal region of a female patient 10 and a male patient 11. The wearable monitor 12 sits centrally (in the midline) on the patient's chest along the sternum 13 oriented top-to-bottom with the monitor recorder 14 preferably situated towards the patient's head. In a further embodiment, the orientation of the wearable monitor 12 can be corrected post-monitoring, as further described infra. The electrode patch 15 is shaped to fit comfortably and conformal to the contours of the patient's chest approximately centered on the sternal midline 16 (or immediately to either side of the sternum 13). The distal end of the electrode patch 15 extends towards the Xiphoid process and, depending upon the patient's build, may straddle the region over the Xiphoid process. The proximal end of the electrode patch 15, located under the monitor recorder 14, is below the manubrium and, depending upon patient's build, may straddle the region over the manubrium.

[0032] The placement of the wearable monitor 12 in a location at the sternal midline 16 (or immediately to either side of the sternum 13) significantly improves the ability of the wearable monitor 12 to cutaneously sense cardiac electric signals, particularly the P-wave (or atrial activity) and, to a lesser extent, the QRS interval signals in the ECG waveforms that indicate ventricular activity, while simultaneously facilitating comfortable long-term wear for many weeks. The sternum 13 overlies the right atrium of the heart and the placement of the wearable monitor 12 in the region of the sternal midline 13 puts the ECG electrodes of the electrode patch 15 in a location better adapted to sensing and recording P-wave signals than other placement locations, say, the upper left pectoral region or lateral thoracic region or the limb leads. In addition, placing the lower or inferior pole (ECG electrode) of the electrode patch 15 over (or near) the Xiphoid process facilitates sensing of ventricular activity and provides superior recordation of the QRS interval.

[0033] The monitor recorder 14 of the extended wear electrocardiography and physiological sensor monitor 12 senses and records the patient's ECG data into an onboard memory. Over time, disposable electrode patches 15 will require replacement and ensuring that the level of quality of ECG recording and patient service remains constant over an extended period of time is dependent upon the monitoring equipment, particularly the replacement electrode patches 15, being up to a known standard. FIG. 3 is a functional block diagram showing a system 120 for providing a self-authenticating electrocardiography monitoring circuit in accordance with one embodiment. Self-authentication allows quality and safety expectations to be maintained. The monitor recorder 14 is a reusable component that can be fitted during patient monitoring into a non-conductive receptacle provided on the electrode patch 15, as further described infra with reference to FIG. 4, and later removed for offloading of stored ECG data or to receive revised programming. The monitor recorder 14 executes an authentication protocol as part of a power up sequence, as further described infra with reference to FIG. 11. Following completion of ECG monitoring, the monitor recorder 14 can be connected to a download station 125, which could be a programmer or other device that permits the retrieval of

stored ECG monitoring data, execution of diagnostics on or programming of the monitor recorder 14, or performance of other functions. The monitor recorder 14 has a set of electrical contacts (not shown) that enable the monitor recorder 14 to physically interface to a set of terminals 128 on a paired receptacle 127 of the download station 125. In turn, the download station 125 executes a communications or offload program 126 (“Offload”) or similar program that interacts with the monitor recorder 14 via the physical interface to retrieve the stored ECG monitoring data. The download station 125 could be a server, personal computer, tablet or handheld computer, smart mobile device, or purpose-built programmer designed specific to the task of interfacing with a monitor recorder 14. Still other forms of download station 125 are possible.

[0034] Upon retrieving stored ECG monitoring data from a monitor recorder 14, middleware first operates on the retrieved data to adjust the ECG waveform, as necessary, and to convert the retrieved data into a format suitable for use by third party post-monitoring analysis software. The formatted data can then be retrieved from the download station 125 over a hard link 135 using a control program 137 (“Ctl”) or analogous application executing on a personal computer 136 or other connectable computing device, via a communications link (not shown), whether wired or wireless, or by physical transfer of storage media (not shown). The personal computer 136 or other connectable device may also execute middleware that converts ECG data and other information into a format suitable for use by a third-party post-monitoring analysis program, as further described infra with reference to FIG. 13. Note that formatted data stored on the personal computer 136 would have to be maintained and safeguarded in the same manner as electronic medical records (EMRs) 134 in the secure database 124, as further discussed infra. In a further embodiment, the download station 125 is able to directly interface with other devices over a computer communications network 121, which could be some combination of a local area network and a wide area network, including the Internet, over a wired or wireless connection.

[0035] A client-server model could be used to employ a server 122 to remotely interface with the download station 125 over the network 121 and retrieve the formatted data or other information. The server 122 executes a patient management program 123 (“Mgt”) or similar application that stores the retrieved formatted data and other information in a secure database 124 cataloged in that patient’s EMRs 134. In addition, the patient management program 123 could manage a subscription service that authorizes a monitor recorder 14 to operate for a set period of time or under pre-defined operational parameters and privileges, such as described in infra with reference to FIG. 13.

[0036] The patient management program 123, or other trusted application, also maintains and safeguards the secure database 124 to limit access to patient EMRs 134 to only authorized parties for appropriate medical or other uses, such as mandated by state or federal law, such as under the Health Insurance Portability and Accountability Act (HIPAA) or per the European Union’s Data Protection Directive. For example, a physician may seek to review and evaluate his patient’s ECG monitoring data, as securely stored in the secure database 124. The physician would execute an application program 130 (“Pgm”), such as a post-monitoring ECG analysis program, on a personal com-

puter 129 or other connectable computing device, and, through the application 130, coordinate access to his patient’s EMRs 134 with the patient management program 123. Other schemes and safeguards to protect and maintain the integrity of patient EMRs 134 are possible.

[0037] During use, the electrode patch 15 is first adhered to the skin along the sternal midline 16 (or immediately to either side of the sternum 13). A monitor recorder 14 is then snapped into place on the electrode patch 15 to initiate ECG monitoring. FIG. 4 is a perspective view showing an extended wear electrode patch 15 with a monitor recorder 14 in accordance with one embodiment inserted. The body of the electrode patch 15 is preferably constructed using a flexible backing 20 formed as an elongated strip 21 of wrap knit or similar stretchable material with a narrow longitudinal mid-section 23 evenly tapering inward from both sides. A pair of cut-outs 22 between the distal and proximal ends of the electrode patch 15 create a narrow longitudinal midsection 23 or “isthmus” and defines an elongated “hour-glass”-like shape, when viewed from above.

[0038] The electrode patch 15 incorporates features that significantly improve wearability, performance, and patient comfort throughout an extended monitoring period. During wear, the electrode patch 15 is susceptible to pushing, pulling, and torquing movements, including compressional and torsional forces when the patient bends forward, and tensile and torsional forces when the patient leans backwards. To counter these stress forces, the electrode patch 15 incorporates strain and crimp reliefs, such as described in commonly-assigned U.S. Pat. No. 9,545,204, issued Jan. 17, 2017, the disclosure of which is incorporated by reference. In addition, the cut-outs 22 and longitudinal midsection 23 help minimize interference with and discomfort to breast tissue, particularly in women (and gynecomastic men). The cut-outs 22 and longitudinal midsection 23 further allow better conformity of the electrode patch 15 to sternal bowing and to the narrow isthmus of flat skin that can occur along the bottom of the intermammary cleft between the breasts, especially in buxom women. The cut-outs 22 and longitudinal midsection 23 help the electrode patch 15 fit nicely between a pair of female breasts in the intermammary cleft. Still other shapes, cut-outs and conformities to the electrode patch 15 are possible.

[0039] The monitor recorder 14 removably and reusably snaps into an electrically non-conductive receptacle 25 during use. The monitor recorder 14 contains electronic circuitry for recording and storing the patient’s electrocardiography as sensed via a pair of ECG electrodes provided on the electrode patch 15, such as described in commonly-assigned U.S. Pat. No. 9,730,593, issued Aug. 15, 2017, the disclosure of which is incorporated by reference. The non-conductive receptacle 25 is provided on the top surface of the flexible backing 20 with a retention catch 26 and tension clip 27 molded into the non-conductive receptacle 25 to conformably receive and securely hold the monitor recorder 14 in place.

[0040] The monitor recorder 14 includes a sealed housing that snaps into place in the non-conductive receptacle 25. FIG. 5 is a perspective view showing the monitor recorder 14 of FIG. 4. The sealed housing 50 of the monitor recorder 14 intentionally has a rounded isosceles trapezoidal-like shape 52, when viewed from above, such as described in commonly-assigned U.S. Design Pat. No. D717955, issued Nov. 18, 2014, the disclosure of which is incorporated by

reference. The edges **51** along the top and bottom surfaces are rounded for patient comfort. The sealed housing **50** is approximately 47 mm long, 23 mm wide at the widest point, and 7 mm high, excluding a patient-operable tactile-feedback button **55**. The sealed housing **50** can be molded out of polycarbonate, ABS, or an alloy of those two materials. The button **55** is waterproof and the button's top outer surface is molded silicon rubber or similar soft pliable material. A retention detent **53** and tension detent **54** are molded along the edges of the top surface of the housing **50** to respectively engage the retention catch **26** and the tension clip **27** molded into non-conductive receptacle **25**. Other shapes, features, and conformities of the sealed housing **50** are possible.

**[0041]** The electrode patch **15** is intended to be disposable. The monitor recorder **14**, however, is reusable and can be transferred to successive electrode patches **15** to ensure continuity of monitoring. The placement of the wearable monitor **12** in a location at the sternal midline **16** (or immediately to either side of the sternum **13**) benefits long-term extended wear by removing the requirement that ECG electrodes be continually placed in the same spots on the skin throughout the monitoring period. Instead, the patient is free to place an electrode patch **15** anywhere within the general region of the sternum **13**.

**[0042]** As a result, at any point during ECG monitoring, the patient's skin is able to recover from the wearing of an electrode patch **15**, which increases patient comfort and satisfaction, while the monitor recorder **14** ensures ECG monitoring continuity with minimal effort. A monitor recorder **14** is merely unsnapped from a worn out electrode patch **15**, the worn out electrode patch **15** is removed from the skin, a new electrode patch **15** is adhered to the skin, possibly in a new spot immediately adjacent to the earlier location, and the same monitor recorder **14** is snapped into the new electrode patch **15** to reinitiate and continue the ECG monitoring.

**[0043]** During use, the electrode patch **15** is first adhered to the skin in the sternal region. FIG. 6 is a perspective view showing the extended wear electrode patch **15** of FIG. 4 without a monitor recorder **14** inserted. A flexible circuit **32** is adhered to each end of the flexible backing **20**. A distal circuit trace **33** and a proximal circuit trace (not shown) electrically couple ECG electrodes (not shown) to a pair of electrical pads **34**. The electrical pads **34** are provided within a moisture-resistant seal **35** formed on the bottom surface of the non-conductive receptacle **25**. When the monitor recorder **14** is securely received into the non-conductive receptacle **25**, that is, snapped into place, the electrical pads **34** interface to electrical contacts (not shown) protruding from the bottom surface of the monitor recorder **14**, and the moisture-resistant seal **35** enables the monitor recorder **14** to be worn at all times, even during bathing or other activities that could expose the monitor recorder **14** to moisture.

**[0044]** In addition, a battery compartment **36** is formed on the bottom surface of the non-conductive receptacle **25**, and a pair of battery leads (not shown) electrically interface the battery to another pair of the electrical pads **34**. The battery contained within the battery compartment **35** can be replaceable, rechargeable or disposable.

**[0045]** The monitor recorder **14** draws power externally from the battery provided in the non-conductive receptacle **25**, thereby uniquely obviating the need for the monitor recorder **14** to carry a dedicated power source. FIG. 7 is a bottom plan view of the monitor recorder **14** of FIG. 4. A

cavity **58** is formed on the bottom surface of the sealed housing **50** to accommodate the upward projection of the battery compartment **36** from the bottom surface of the non-conductive receptacle **25**, when the monitor recorder **14** is secured in place on the non-conductive receptacle **25**. A set of electrical contacts **56** protrude from the bottom surface of the sealed housing **50** and are arranged in alignment with the electrical pads **34** provided on the bottom surface of the non-conductive receptacle **25** to establish electrical connections between the electrode patch **15** and the monitor recorder **14**. In addition, a seal coupling **57** circumferentially surrounds the set of electrical contacts **56** and securely mates with the moisture-resistant seal **35** formed on the bottom surface of the non-conductive receptacle **25**.

**[0046]** The placement of the flexible backing **20** on the sternal midline **16** (or immediately to either side of the sternum **13**) also helps to minimize the side-to-side movement of the wearable monitor **12** in the left- and right-handed directions during wear. To counter the dislodgment of the flexible backing **20** due to compressional and torsional forces, a layer of non-irritating adhesive, such as hydrocolloid, is provided at least partially on the underside, or contact, surface of the flexible backing **20**, but only on the distal end **30** and the proximal end **31**. As a result, the underside, or contact surface of the longitudinal midsection **23** does not have an adhesive layer and remains free to move relative to the skin. Thus, the longitudinal midsection **23** forms a crimp relief that respectively facilitates compression and twisting of the flexible backing **20** in response to compressional and torsional forces. Other forms of flexible backing crimp reliefs are possible.

**[0047]** Unlike the flexible backing **20**, the flexible circuit **32** is only able to bend and cannot stretch in a planar direction. The flexible circuit **32** can be provided either above or below the flexible backing **20**. FIG. 8 is a top view showing the flexible circuit **32** of the extended wear electrode patch **15** of FIG. 4 when mounted above the flexible backing **20**. A distal ECG electrode **38** and proximal ECG electrode **39** are respectively coupled to the distal and proximal ends of the flexible circuit **32**. A strain relief **40** is defined in the flexible circuit **32** at a location that is partially underneath the battery compartment **36** when the flexible circuit **32** is affixed to the flexible backing **20**. The strain relief **40** is laterally extendable to counter dislodgment of the ECG electrodes **38**, **39** due to tensile and torsional forces. A pair of strain relief cutouts **41** partially extend transversely from each opposite side of the flexible circuit **32** and continue longitudinally towards each other to define in 'S'-shaped pattern, when viewed from above. The strain relief respectively facilitates longitudinal extension and twisting of the flexible circuit **32** in response to tensile and torsional forces. Other forms of circuit board strain relief are possible.

**[0048]** ECG monitoring and other functions performed by the monitor recorder **14** are provided through a micro controlled architecture. FIG. 9 is a functional block diagram showing the component architecture of the circuitry **60** of the monitor recorder **14** of FIG. 4. The circuitry **60** is externally powered through a battery provided in the non-conductive receptacle **25** (shown in FIG. 6). Both power and raw ECG signals, which originate in the pair of ECG electrodes **38**, **39** (shown in FIG. 8) on the distal and proximal ends of the electrode patch **15**, are received through an external connector **65** that mates with a corre-

sponding physical connector on the electrode patch 15. The external connector 65 includes the set of electrical contacts 56 that protrude from the bottom surface of the sealed housing 50 and which physically and electrically interface with the set of pads 34 provided on the bottom surface of the non-conductive receptacle 25. The external connector includes electrical contacts 56 for data download, micro-controller communications, power, analog inputs, and a peripheral expansion port. The arrangement of the pins on the electrical connector 65 of the monitor recorder 14 and the device into which the monitor recorder 14 is attached, whether an electrode patch 15 or download station (not shown), follow the same electrical pin assignment convention to facilitate interoperability. The external connector 65 also serves as a physical interface to a download station that permits the retrieval of stored ECG monitoring data, communication with the monitor recorder 14, and performance of other functions.

[0049] Operation of the circuitry 60 of the monitor recorder 14 is managed by a microcontroller 61. The microcontroller 61 includes a program memory unit containing internal flash memory that is readable and writeable. The internal flash memory can also be programmed externally. The microcontroller 61 draws power externally from the battery provided on the electrode patch 15 via a pair of the electrical contacts 56. The microcontroller 61 connects to the ECG front end circuit 63 that measures raw cutaneous electrical signals and generates an analog ECG signal representative of the electrical activity of the patient's heart over time.

[0050] The circuitry 60 of the monitor recorder 14 also includes a flash memory 62, which the microcontroller 61 uses for storing ECG monitoring data and other physiology and information. The flash memory 62 also draws power externally from the battery provided on the electrode patch 15 via a pair of the electrical contacts 56. Data is stored in a serial flash memory circuit, which supports read, erase and program operations over a communications bus. The flash memory 62 enables the microcontroller 61 to store digitized ECG data. The communications bus further enables the flash memory 62 to be directly accessed externally over the external connector 65 when the monitor recorder 14 is interfaced to a download station.

[0051] The circuitry 60 of the monitor recorder 14 further includes an actigraphy sensor 64 implemented as a 3-axis accelerometer. The accelerometer may be configured to generate interrupt signals to the microcontroller 61 by independent initial wake up and free fall events, as well as by device position. In addition, the actigraphy provided by the accelerometer can be used during post-monitoring analysis to correct the orientation of the monitor recorder 14 if, for instance, the monitor recorder 14 has been inadvertently installed upside down, that is, with the monitor recorder 14 oriented on the electrode patch 15 towards the patient's feet, as well as for other event occurrence analyses, such as described in commonly-assigned U.S. Pat. No. 9,737,224, issued Aug. 22, 2017, the disclosure of which is incorporated by reference.

[0052] The microcontroller 61 includes an expansion port that also utilizes the communications bus. External devices, separately drawing power externally from the battery provided on the electrode patch 15 or other source, can interface to the microcontroller 61 over the expansion port in half duplex mode. For instance, an external physiology sensor

can be provided as part of the circuitry 60 of the monitor recorder 14, or can be provided on the electrode patch 15 with communication with the micro-controller 61 provided over one of the electrical contacts 56. The physiology sensor can include a SpO<sub>2</sub> sensor, blood pressure sensor, temperature sensor, respiratory rate sensor, glucose sensor, airflow sensor, volumetric pressure sensing, or other types of sensor or telemetric input sources. For instance, the integration of an airflow sensor is described in commonly-assigned U.S. Pat. No. 9,364,155, issued Jun. 14, 2016, the disclosure of which is incorporated by reference. In a further embodiment, a wireless interface for interfacing with other wearable (or implantable) physiology monitors, as well as data offload and programming, can be provided as part of the circuitry 60 of the monitor recorder 14, or can be provided on the electrode patch 15 with communication with the microcontroller 61 provided over one of the electrical contacts 56, such as described in commonly-assigned U.S. Pat. No. 9,433,367, issued Sep. 6, 2016 the disclosure of which is incorporated by reference.

[0053] Finally, the circuitry 60 of the monitor recorder 14 includes patient-interfaceable components, including a tactile feedback button 66, which a patient can press to mark events or to perform other functions, and a buzzer 67, such as a speaker, magnetic resonator or piezoelectric buzzer. The buzzer 67 can be used by the microcontroller 61 to output feedback to a patient such as to confirm power up and initiation of ECG monitoring. Still other components as part of the circuitry 60 of the monitor recorder 14 are possible.

[0054] While the monitor recorder 14 operates under micro control, most of the electrical components of the electrode patch 15 operate passively. FIG. 10 is a functional block diagram showing the circuitry 70 of the extended wear electrode patch 15 of FIG. 4. The circuitry 70 of the electrode patch 15 is electrically coupled with the circuitry 60 of the monitor recorder 14 through an external connector 74. The external connector 74 is terminated through the set of pads 34 provided on the bottom of the non-conductive receptacle 25, which electrically mate to corresponding electrical contacts 56 protruding from the bottom surface of the sealed housing 50 to electrically interface the monitor recorder 14 to the electrode patch 15.

[0055] The circuitry 70 of the electrode patch 15 performs three primary functions. First, a battery 71 is provided in a battery compartment formed on the bottom surface of the non-conductive receptacle 25. The battery 71 is electrically interfaced to the circuitry 60 of the monitor recorder 14 as a source of external power. The unique provisioning of the battery 71 on the electrode patch 15 provides several advantages. First, the locating of the battery 71 physically on the electrode patch 15 lowers the center of gravity of the overall wearable monitor 12 and thereby helps to minimize shear forces and the effects of movements of the patient and clothing. Moreover, the housing 50 of the monitor recorder 14 is sealed against moisture and providing power externally avoids having to either periodically open the housing 50 for the battery replacement, which also creates the potential for moisture intrusion and human error, or to recharge the battery, which can potentially take the monitor recorder 14 off line for hours at a time. In addition, the electrode patch 15 is intended to be disposable, while the monitor recorder 14 is a reusable component. Each time that the electrode patch 15 is replaced, a fresh battery is provided for the use of the monitor recorder 14, which enhances ECG monitoring

performance quality and duration of use. Finally, the architecture of the monitor recorder **14** is open, in that other physiology sensors or components can be added by virtue of the expansion port of the microcontroller **61**. Requiring those additional sensors or components to draw power from a source external to the monitor recorder **14** keeps power considerations independent of the monitor recorder **14**. Thus, a battery of higher capacity could be introduced when needed to support the additional sensors or components without effecting the monitor recorders circuitry **60**.

**[0056]** Second, the pair of ECG electrodes **38, 39** respectively provided on the distal and proximal ends of the flexible circuit **32** are electrically coupled to the set of pads **34** provided on the bottom of the non-conductive receptacle **25** by way of their respective circuit traces **33, 37**. The signal ECG electrode **39** includes a protection circuit **72**, which is an inline resistor that protects the patient from excessive leakage current.

**[0057]** Last, in a further embodiment, the circuitry **70** of the electrode patch **15** includes a cryptographic circuit **73** to authenticate an electrode patch **15** for use with a monitor recorder **14**. The cryptographic circuit **73** includes a device capable of secure authentication and validation. The cryptographic device **73** ensures that only genuine, non-expired, safe, and authenticated electrode patches **15** are permitted to provide monitoring data to a monitor recorder **14**.

**[0058]** The monitor recorder **14** continuously monitors the patient's heart rate and physiology. FIG. **11** is a flow diagram showing a monitor recorder-implemented method **100** for monitoring ECG data for use in the monitor recorder **14** of FIG. **4**. Initially, upon being connected to the set of pads **34** provided with the non-conductive receptacle **25** when the monitor recorder **14** is snapped into place, the microcontroller **61** executes a power up sequence (step **101**) and performs self-authentication of the electrode patch **15** (step **102**). During the power up sequence, the voltage of the battery **71** is checked, the state of the flash memory **62** is confirmed, both in terms of operability check and available capacity, and microcontroller operation is diagnostically confirmed.

**[0059]** Self-authentication is performed between the microcontroller **61** and the electrode patch **15** each time that the monitor recorder **14** is inserted into an electrode patch **15** (or other accessory) to ensure patient safety. An authenticated patch will conform to product quality standards, as well as applicable federal regulatory quality requirements and international standards, such as ISO 13485, IEC 60601-2-47 and IEC 60601-1. Quality assurance, through self-authentication, is crucial, as electrode patches **15** and other accessories may be authorized, but may not necessarily be manufactured, by the entity ultimately responsible for quality standards compliance. Self-authentication mitigates the risk of incorrect device output due to non-compliant accessories.

**[0060]** In one embodiment, the micro-controller **61** contains a private key or a precomputed digest, of which the electrode patch **15** (or other accessory) will have a copy. To authenticate an electrode patch **15** (or other accessory), the micro-controller **61** will challenge the electrode patch **15** (or other accessory) using a code hashed with the private key or precomputed digest. If the electrode patch **15** (or other accessory) responds correctly, the micro-controller **61** will continue with normal program execution. Otherwise, the monitor recorder **14** will signal an error condition, such as

chirping the buzzer **67** to notify the patient. Failing self-authentication, other actions could also be taken.

**[0061]** In a further embodiment, an electrode patch **15** (or other accessory) can be set to operate for only a certain period of time. Upon authentication, the monitor recorder **14** will run with that electrode patch **15** (or other accessory) until the electrode patch **15** (or other accessory) is depleted. If the electrode patch **15** (or other accessory) is detected to be expired during self-authentication, the monitor recorder **14** will fail to operate or signal an error condition. To cause an electrode patch **15** (or other accessory) to expire after a certain amount of time has elapsed, the micro-controller **61** periodically writes into the read-only memory (ROM) of the cryptographic circuit **73**. After the data in the ROM written by the micro-controller **61** has reached a certain fullness, the micro-controller **61** will turn off to ensure that an expired electrode patch **15** (or other accessory) does not create an unsafe condition, such as an incorrect output. Still other forms of authentication and device expiration are possible.

**[0062]** Following satisfactory completion of the power up sequence, an iterative processing loop (steps **103-110**) is continually executed by the microcontroller **61**. During each iteration (step **103**) of the processing loop, the ECG frontend **63** (shown in FIG. **9**) continually senses the cutaneous ECG electrical signals (step **104**) via the ECG electrodes **38, 29** and is optimized to maintain the integrity of the P-wave. A sample of the ECG signal is read (step **105**) by the microcontroller **61** by sampling the analog ECG signal output front end **63**. FIG. **12** is a graph showing, by way of example, a typical ECG waveform **110**. The x-axis represents time in approximate units of tenths of a second. The y-axis represents cutaneous electrical signal strength in approximate units of millivolts. The P-wave **111** has a smooth, normally upward, that is, positive, waveform that indicates atrial depolarization. The QRS complex usually begins with the downward deflection of a Q wave **112**, followed by a larger upward deflection of an R-wave **113**, and terminated with a downward waveform of the S wave **114**, collectively representative of ventricular depolarization. The T wave **115** is normally a modest upward waveform, representative of ventricular depolarization, while the U wave **116**, often not directly observable, indicates the recovery period of the Purkinje conduction fibers.

**[0063]** Sampling of the R-to-R interval enables heart rate information derivation. For instance, the R-to-R interval represents the ventricular rate and rhythm, while the P-to-P interval represents the atrial rate and rhythm. Importantly, the PR interval is indicative of atrioventricular (AV) conduction time and abnormalities in the PR interval can reveal underlying heart disorders, thus representing another reason why the P-wave quality achievable by the extended wear ambulatory electrocardiography and physiological sensor monitor described herein is medically unique and important. The long-term observation of these ECG indicia, as provided through extended wear of the wearable monitor **12**, provides valuable insights to the patient's cardiac function and overall well-being.

**[0064]** Each sampled ECG signal, in quantized and digitized form, is temporarily staged in buffer (step **106**), pending compression preparatory to storage in the flash memory **62** (step **107**). Following compression, the compressed ECG digitized sample is again buffered (step **108**), then written to the flash memory **62** (step **109**) using the communications bus. Processing continues (step **110**), so long as the moni-

toring recorder 14 remains connected to the electrode patch 15 (and storage space remains available in the flash memory 62), after which the processing loop is exited and execution terminates. Still other operations and steps are possible.

[0065] The patient management program 123 could manage a subscription service that authorizes a monitor recorder 14 to operate for a set period of time or under pre-defined operational parameters and privileges. FIG. 13 is a flow diagram showing a method 150 for providing a self-authenticating electrocardiography monitoring circuit in accordance with one embodiment. The method 150 can be implemented in software and execution of the software can be performed on a download station 125, which could be a programmer or other device, or a computer system, including a server 122 or personal computer 129, such as further described supra with reference to FIG. 3, as a series of process or method modules or steps.

[0066] For convenience, the method 150 will be described in the context of being performed by a personal computer 136 or other connectable computing device (shown in FIG. 3) as middleware that converts ECG data and other information into a format suitable for use by a third-party post-monitoring analysis program. Execution of the method 150 by a computer system would be analogous mutatis mutandis.

[0067] Initially, the download station 125 is connected to the monitor recorder 14 (step 151), such as by physically interfacing to a set of terminals 128 on a paired receptacle 127 or by wireless connection, if available. The data stored on the monitor recorder 14, including ECG and physiological monitoring data, other recorded data, and other information are retrieved (step 152) over a hard link 135 using a control program 137 ("Ctl") or analogous application executing on a personal computer 136 or other connectable computing device.

[0068] The data retrieved from the monitor recorder 14 is in a proprietary storage format and each datum of recorded ECG monitoring data, as well as any other physiological data or other information, must be converted, so that the data can be used by a third-party post-monitoring analysis program. Each datum of ECG monitoring data is converted by the middleware (steps 153-159) in an iterative processing loop. During each iteration (step 153), the ECG datum is read (step 154) and, if necessary, the gain of the ECG signal is adjusted (step 155) to compensate, for instance, for relocation or replacement of the electrode patch 15 during the monitoring period.

[0069] In addition, depending upon the configuration of the wearable monitor 12, other physiological data (or other information), including patient events, such as a fall, peak activity level, detection of patient activity levels and states, sedentary detection and so on, may be recorded along with the ECG monitoring data. For instance, actigraphy data may have been sampled by the actigraphy sensor 64 based on a sensed event occurrence, such as a sudden change in orientation due to the patient taking a fall. In response, the monitor recorder 14 will embed the actigraphy data samples into the stream of data, including ECG monitoring data that is recorded to the flash memory 62 by the micro-controller 61. Post-monitoring, the actigraphy data is temporally matched to the ECG data to provide the proper physiological context to the sensed event occurrence. As a result, the three-axis actigraphy signal is turned into an actionable event occurrence that is provided, through conversion by the

middleware, to third party post-monitoring analysis programs, along with the ECG recordings contemporaneous to the event occurrence. Other types of processing of the other physiological data (or other information) are possible.

[0070] Thus, during execution of the middleware, any other physiological data (or other information) that has been embedded into the recorded ECG monitoring data is read (step 156) and time-correlated to the time frame of the ECG signals that occurred at the time that the other physiological data (or other information) was noted (step 157). Finally, the ECG datum, signal gain adjusted, if appropriate, and other physiological data, if applicable and as time-correlated, are stored in a format suitable to the backend software (step 158) used in post-monitoring analysis.

[0071] While the invention has been particularly shown and described as referenced to the embodiments thereof, those skilled in the art will understand that the foregoing and other changes in form and detail may be made therein without departing from the spirit and scope.

What is claimed is:

1. An electrocardiography and physiological sensor monitor recorder with a self-authenticating electrocardiography monitoring circuit, comprising:

a sealed housing adapted to be removably secured on an electrode patch; and

electronic circuitry comprised within the housing and comprising:

a microcontroller comprising a private key or precomputed digest, wherein a copy of the private key or precomputed digest is stored on the electrode patch, and configured to perform self-authentication with the electrode patch each time the housing is inserted into a new electrode patch by challenging the electrode patch using a code hashed with the private key or precomputed digest and by receiving a response from the electrode patch in reply to the challenge; and

an electrocardiographic front end circuit electrically interfaced to the microcontroller to sense electrocardiographic signals via electrodes on the electrode patch when the response received by the microcontroller is positive and to continue to sense the electrocardiographic signals until the electrode patch expires.

2. An electrocardiography and physiological sensor monitor recorder according to claim 1, wherein the electronic circuitry comprises an actigraphy sensor to sample actigraphy data and to generate interrupt signals to the microcontroller by one of independent initial wake up and free fall devices.

3. An electrocardiography and physiological sensor monitor recorder according to claim 2, wherein an orientation of the housing is determined based on the actigraphy data.

4. An electrocardiography and physiological sensor monitor recorder according to claim 2, wherein the actigraphy data is embedded into a stream of the electrocardiographic signals.

5. An electrocardiography and physiological sensor monitor recorder according to claim 2, wherein the actigraphy data is temporally matched to the electrocardiographic signals after the stream is offloaded via the electronic circuitry.

6. An electrocardiography and physiological sensor monitor recorder according to claim 1, wherein the electronic

circuitry comprises an expansion port to interface one or more external devices to the microcontroller.

7. An electrocardiography and physiological sensor monitor recorder according to claim 6, wherein each external device comprises one of an SpO<sub>2</sub> sensor, blood pressure sensor, temperature sensor, respiratory rate sensor, glucose sensor, airflow sensor, and volumetric pressure sensor.

8. An electrocardiography and physiological sensor monitor recorder according to claim 1, further comprising:  
a feedback button comprised on the housing to mark patient events.

9. An electrocardiography and physiological sensor monitor recorder according to claim 1, further comprising:  
a buzzer comprising at least one of a speaker, magnetic resonator, and piezoelectric buzzer to output feedback.

10. An electrocardiography and physiological sensor monitor recorder according to claim 1, further comprising:  
memory configured to draw power from a battery provided on the electrode patch.

11. A self-authenticating electrocardiography and physiological sensor monitor, comprising:  
an electrode patch, comprising:

- an elongated strip of material;
- a pair of electrocardiographic electrodes exposed on a contact surface of each end of the elongated strip;
- a non-conductive receptacle adhered to an outward-facing surface of the elongated strip and comprising a plurality of electrical pads; and
- a circuit affixed on each end of the elongated strip and comprising a pair of circuit traces electrically coupled to the pair of the electrocardiographic electrodes and a pair of the electrical pads; and

an electrocardiography monitor recorder having a sealed housing adapted to be removably secured into the non-conductive receptacle on the electrode patch and electronic circuitry comprised within the sealed housing, comprising:

- a microcontroller comprising a private key or precomputed digest, wherein a copy of the private key or precomputed digest is stored on the electrode patch, and configured to perform self-authentication with the electrode patch each time the monitor recorder is inserted into a new electrode patch by challenging the electrode patch using a code hashed with the private key or precomputed digest and by receiving a response from the electrode patch in reply to the challenge; and
- an electrocardiographic front end circuit electrically interfaced to the microcontroller to sense electrocardiographic signals via electrodes on the electrode patch

when the response received by the microcontroller is positive and to continue to sense the electrocardiographic signals until the electrode patch expires.

12. A self-authenticating electrocardiography and physiological sensor monitor according to claim 11, wherein the electronic circuitry comprises an actigraphy sensor to sample actigraphy data and to generate interrupt signals to the microcontroller by one of independent initial wake up and free fall devices.

13. A self-authenticating electrocardiography and physiological sensor monitor according to claim 12, wherein an orientation of the housing is determined based on the actigraphy data.

14. A self-authenticating electrocardiography and physiological sensor monitor according to claim 12, wherein the actigraphy data is embedded into a stream of the electrocardiographic signals.

15. A self-authenticating electrocardiography and physiological sensor monitor according to claim 12, wherein the actigraphy data is temporally matched to the electrocardiographic signals after the stream is offloaded via the electronic circuitry.

16. A self-authenticating electrocardiography and physiological sensor monitor according to claim 11, wherein the electronic circuitry comprises an expansion port to interface one or more external devices to the microcontroller.

17. A self-authenticating electrocardiography and physiological sensor monitor according to claim 16, wherein each external device comprises one of an SpO<sub>2</sub> sensor, blood pressure sensor, temperature sensor, respiratory rate sensor, glucose sensor, airflow sensor, and volumetric pressure sensor.

18. A self-authenticating electrocardiography and physiological sensor monitor according to claim 11, further comprising:

- a feedback button comprised on the housing to mark patient events.

19. A self-authenticating electrocardiography and physiological sensor monitor according to claim 11, further comprising:

- a buzzer comprising at least one of a speaker, magnetic resonator, and piezoelectric buzzer to output feedback.

20. A self-authenticating electrocardiography and physiological sensor monitor according to claim 11, further comprising:

- memory configured to draw power from a battery provided on the electrode patch.

\* \* \* \* \*

专利名称(译)	自认证心电图和生理传感器监控器		
公开(公告)号	<a href="#">US20190380615A1</a>	公开(公告)日	2019-12-19
申请号	US16/558231	申请日	2019-09-02
[标]申请(专利权)人(译)	BARDY诊断		
申请(专利权)人(译)	BARDY诊断, INC.		
当前申请(专利权)人(译)	BARDY诊断, INC.		
[标]发明人	FELIX JASON BARDY GUST H BISHAY JON MIKALSON		
发明人	FELIX, JASON BARDY, GUST H. BISHAY, JON MIKALSON		
IPC分类号	A61B5/0408 A61B5/00 A61B5/0432 A61B5/0402		
CPC分类号	A61B5/04085 A61B5/6823 A61B5/0402 A61B5/0022 A61B5/0006 A61B2562/08 A61B5/04325 A61B5/04087		
优先权	61/882403 2013-09-25 US		
外部链接	<a href="#">Espacenet</a> <a href="#">USPTO</a>		

摘要(译)

提供了一种自认证心电图和生理传感器监控器。电极贴片包括细长条和暴露在每一端的电极。插座被粘附到细长条上并且包括电垫。电路迹线电耦合到心电图电极和电垫。具有密封外壳的监视记录器适于固定到容器中。外壳内的电路包括带有私钥的微控制器。私钥的副本存储在补丁程序中。每次将监控记录器插入新补丁时，都会执行自我认证，方法是使用使用私钥散列的代码对补丁进行质询，并从补丁中收到对挑战的答复。当微控制器接收到的响应为正时，前端电路会通过贴片上的电极感应心电图信号，直到电极贴片到期为止。

