



US 20160367164A1

(19) **United States**

(12) **Patent Application Publication**

Felix et al.

(10) **Pub. No.: US 2016/0367164 A1**

(43) **Pub. Date: Dec. 22, 2016**

(54) **REMOTE INTERFACING OF EXTENDED WEAR ELECTROCARDIOGRAPHY AND PHYSIOLOGICAL SENSOR MONITOR**

A61B 5/0205 (2006.01)

A61B 5/0408 (2006.01)

A61B 5/00 (2006.01)

(71) Applicant: **Bardy Diagnostics, Inc**, Charlotte, NC (US)

(52) **U.S. Cl.**

CPC *A61B 5/04325* (2013.01); *A61B 5/04087*

(2013.01); *A61B 5/04085* (2013.01); *A61B*

5/0006 (2013.01); *A61B 5/0022* (2013.01);

A61B 5/7455 (2013.01); *A61B 5/7405*

(2013.01); *A61B 5/02055* (2013.01); *A61B*

5/14542 (2013.01); *A61B 5/14532* (2013.01);

A61B 5/6823 (2013.01); *A61B 5/7475*

(2013.01); *A61B 2560/0214* (2013.01); *A61B*

5/021 (2013.01)

(72) Inventors: **Jason Felix**, Vashon Island, WA (US);
Jon Mikalson Bishay, Seattle, WA (US);
Gust H. Bardy, Carnation, WA (US)

(21) Appl. No.: **15/256,266**

(22) Filed: **Sep. 2, 2016**

(57)

ABSTRACT

Related U.S. Application Data

(63) Continuation of application No. 14/082,071, filed on Nov. 15, 2013, now Pat. No. 9,433,367, which is a continuation-in-part of application No. 14/080,717, filed on Nov. 14, 2013, said application No. 14/082,071 is a continuation-in-part of application No. 14/080,725, filed on Nov. 14, 2013.

(60) Provisional application No. 61/882,403, filed on Sep. 25, 2013, provisional application No. 61/882,403, filed on Sep. 25, 2013.

Publication Classification

(51) **Int. Cl.**

A61B 5/0432 (2006.01)

A61B 5/145 (2006.01)

A remotely-interfaceable extended wear electrocardiography and physiological sensor monitor recorder is provided. A sealed housing forms on a bottom surface a cavity shaped to accommodate an upward projection of a battery compartment formed on a non-conductive receptacle of a disposable extended wear electrode patch and includes a set of electrical contacts that protrude from the bottom surface and are arranged in alignment with electrical pads provided on the non-conductive receptacle. Electronic circuitry is provided within the sealed housing and includes an externally-powered micro-controller operable to execute under micro programmable control. An electrocardiographic front end circuit is electrically interfaced to the micro-controller. A wireless transceiver electrically interfaces with the micro-controller and externally-powered flash memory is electrically interfaced with the micro-controller and operable to store samples of the electrocardiographic signals.

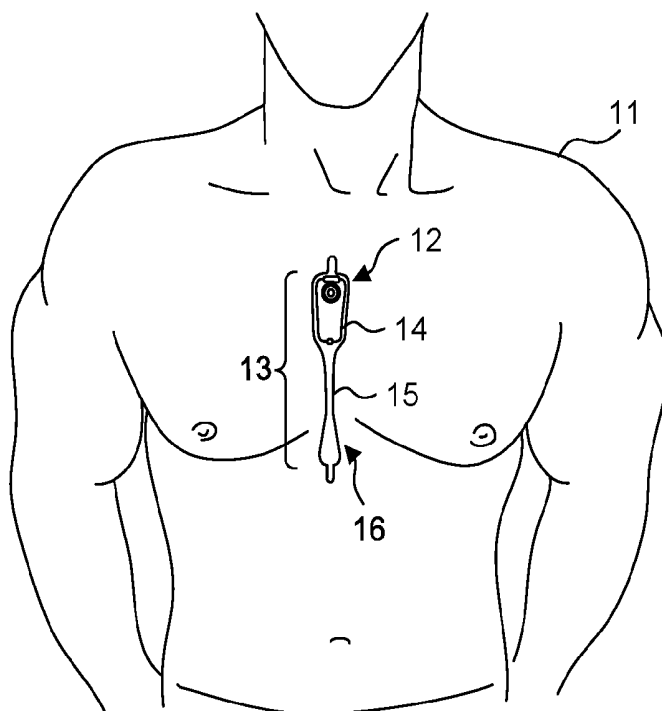

Fig. 1.

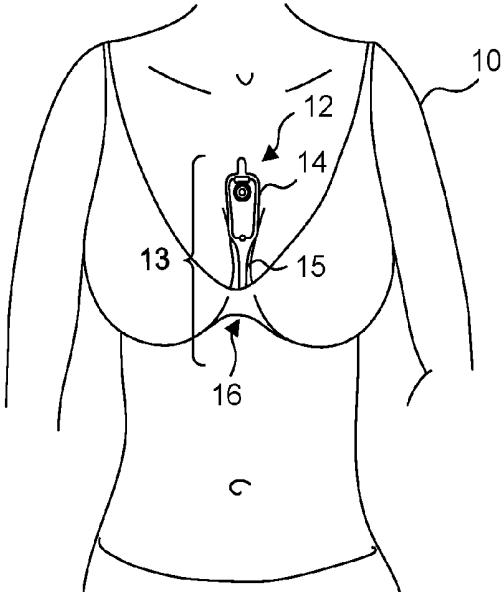

Fig. 2.

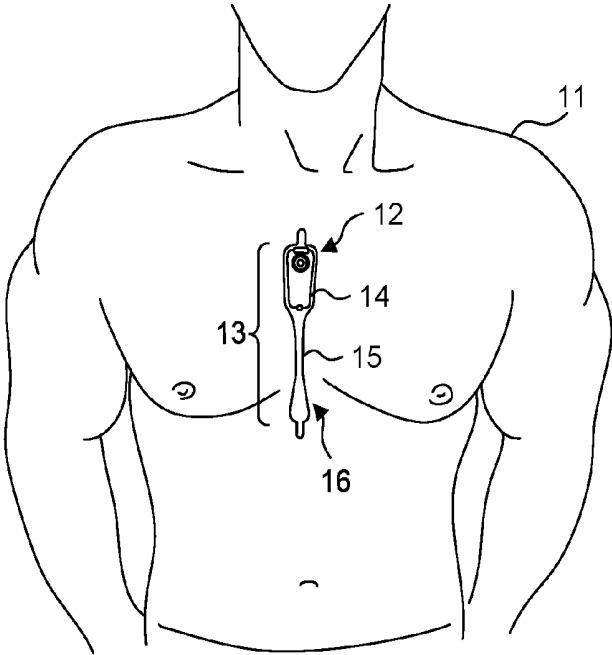

Fig. 3.

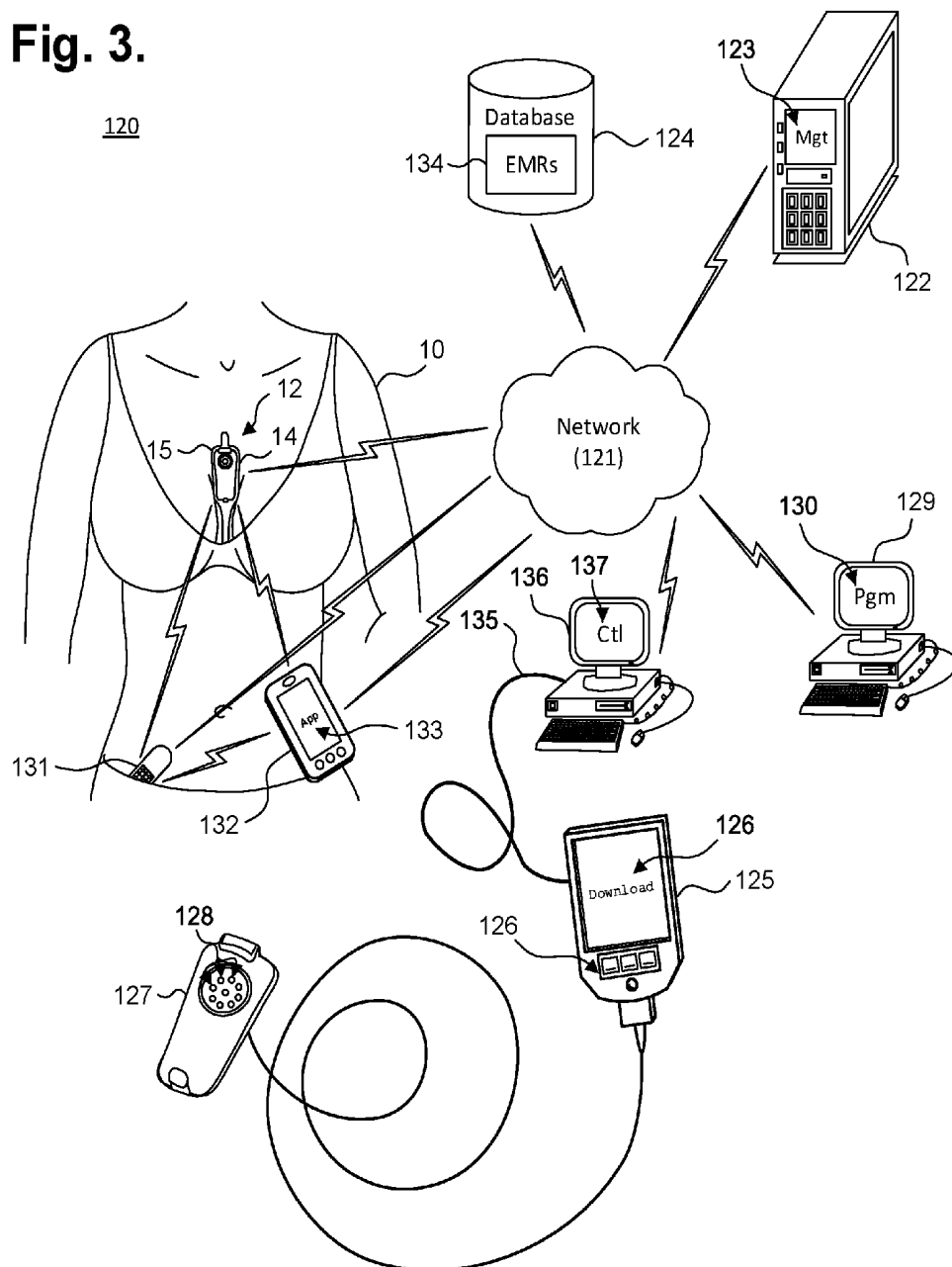

Fig. 4.

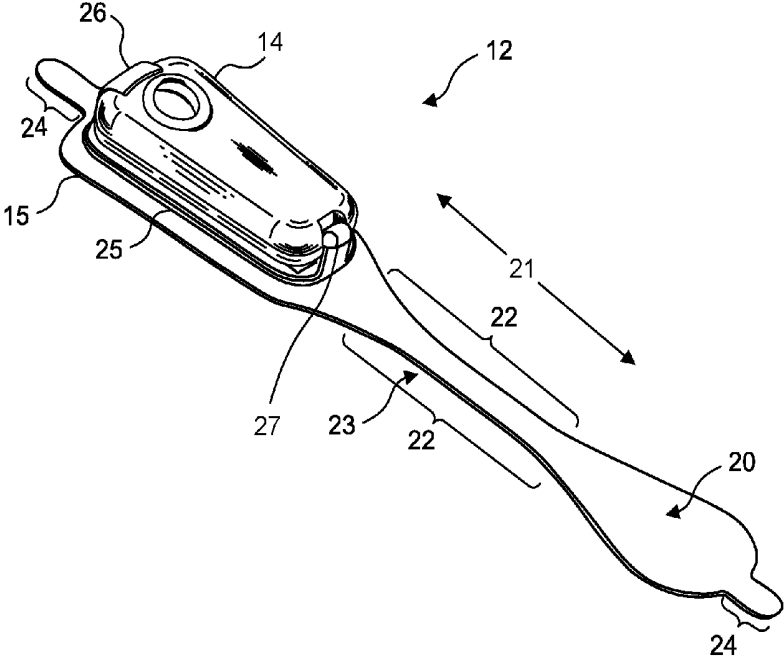

Fig. 5.

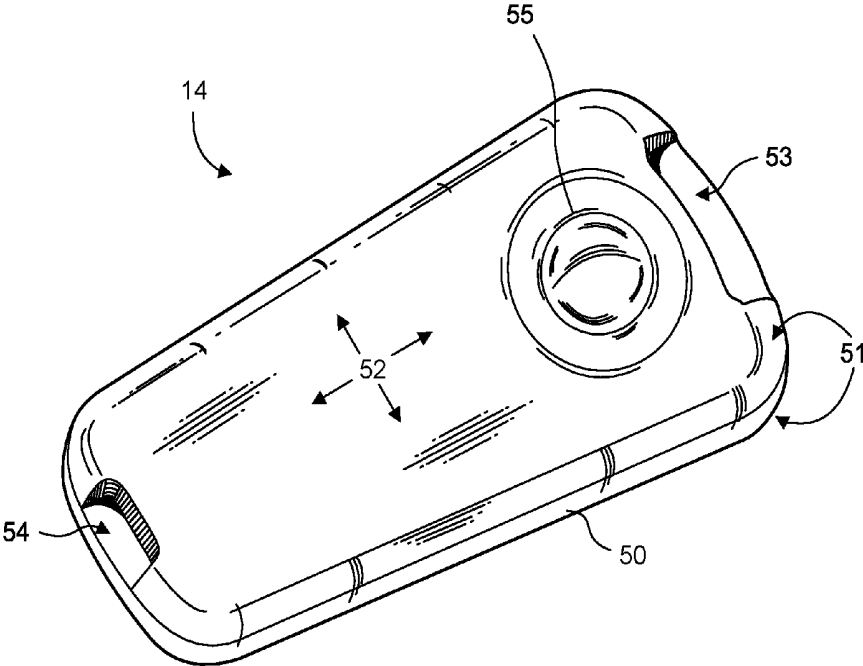

Fig. 6.

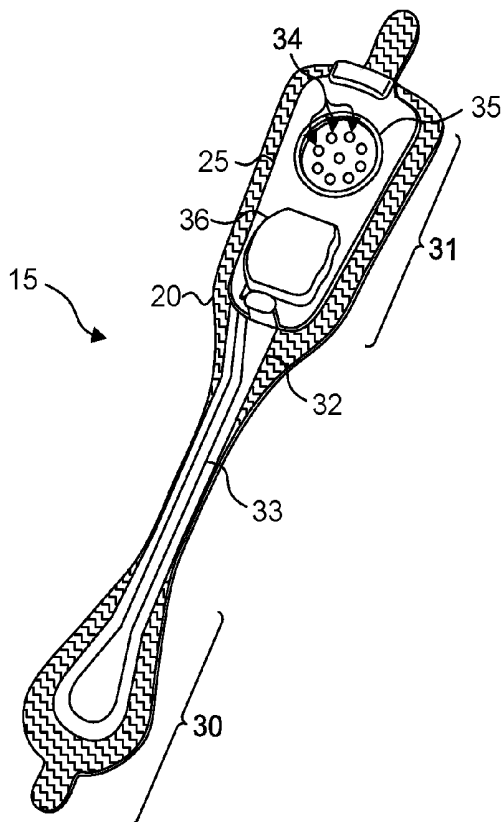

Fig. 7.

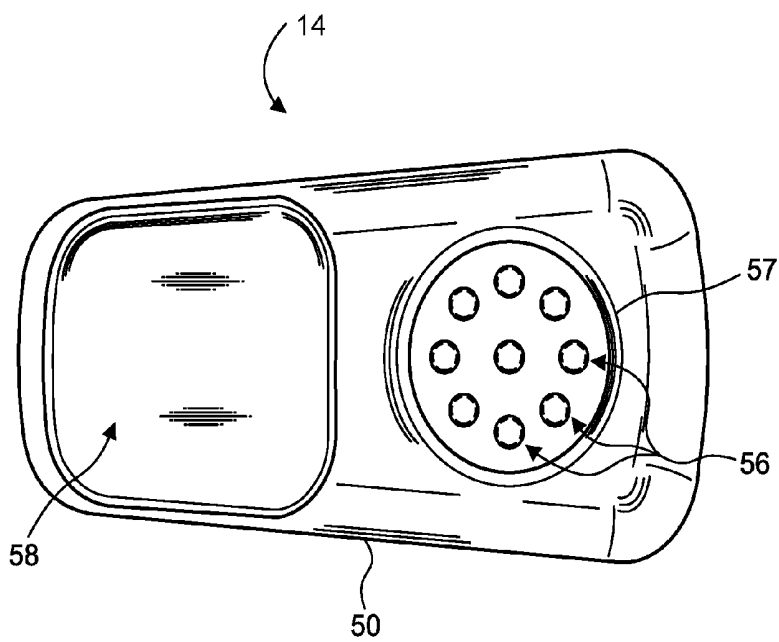

Fig. 8.

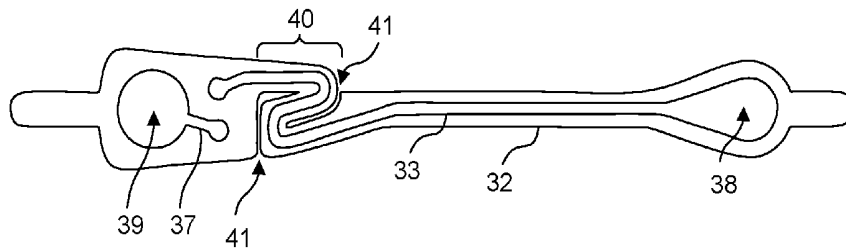

Fig. 9.

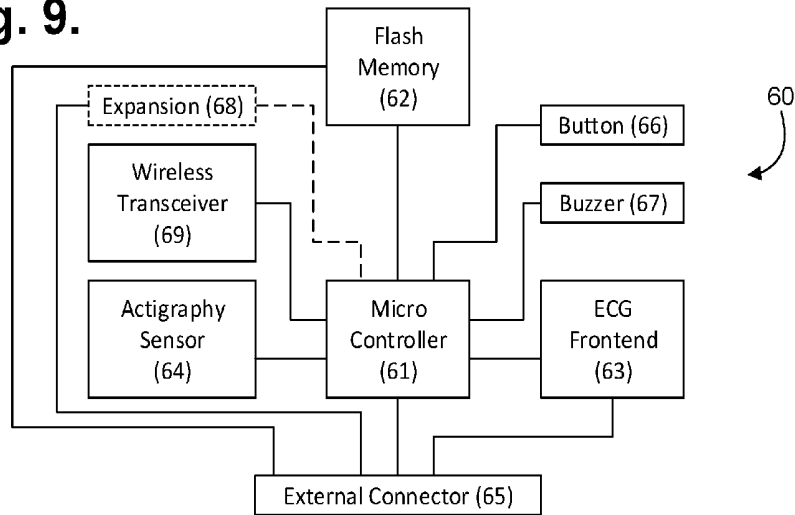

Fig. 10.

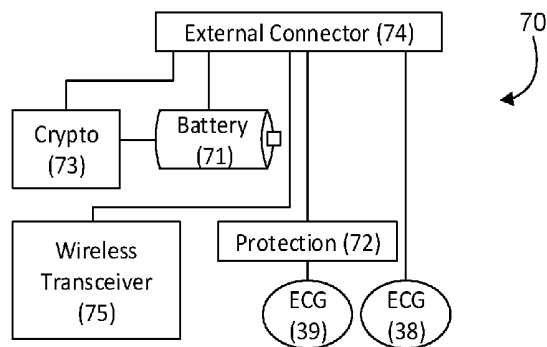

Fig. 11.

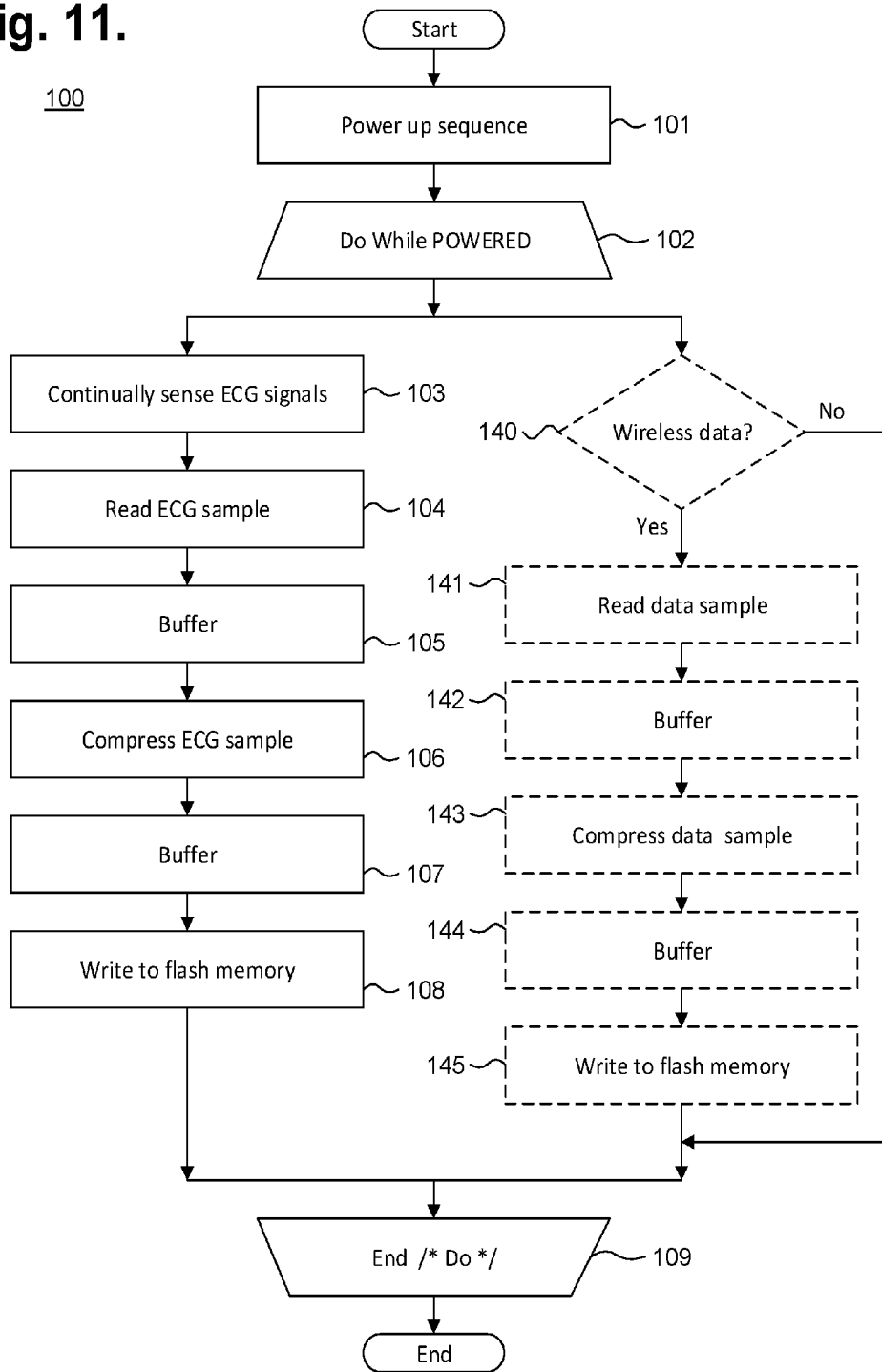

Fig. 12.

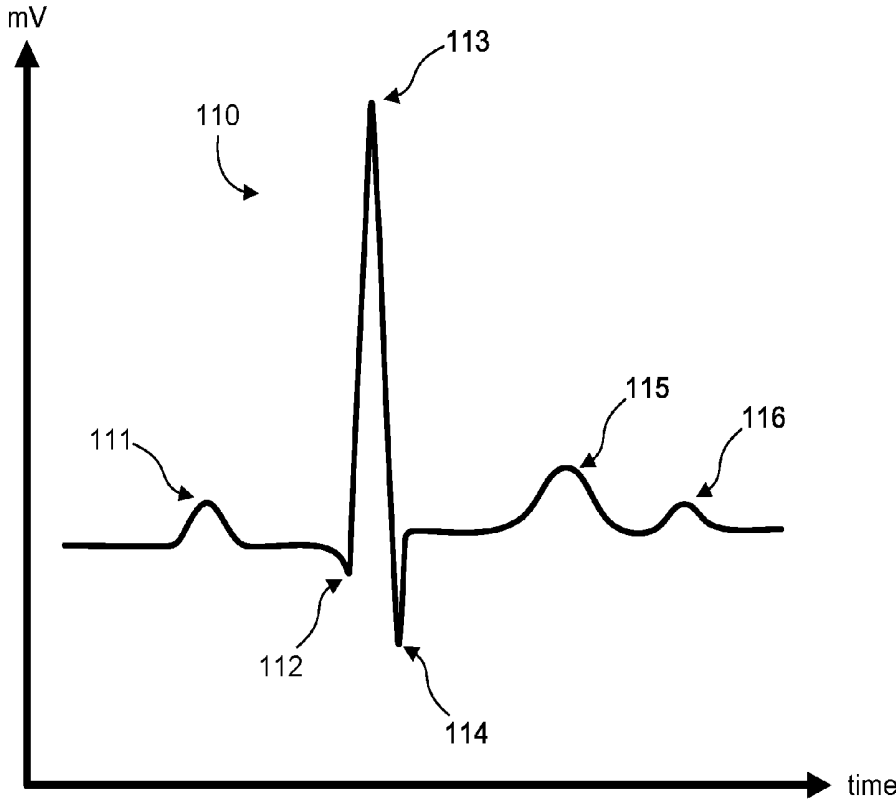
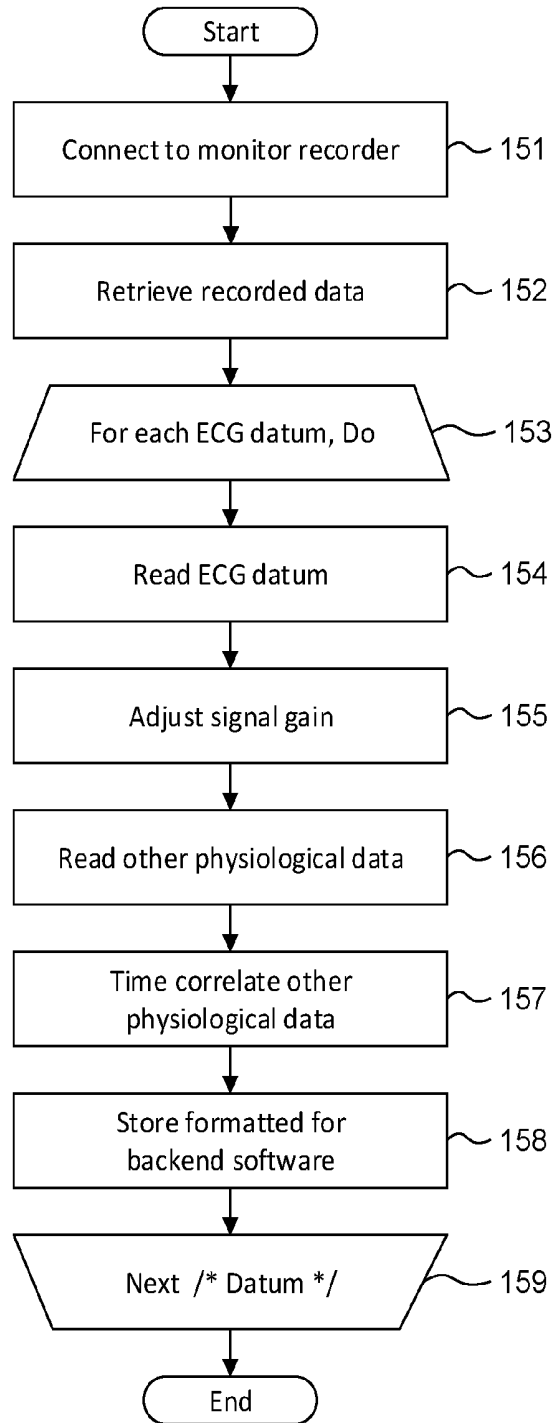

Fig. 13.

150



REMOTE INTERFACING OF EXTENDED WEAR ELECTROCARDIOGRAPHY AND PHYSIOLOGICAL SENSOR MONITOR

CROSS-REFERENCE TO RELATED APPLICATION

[0001] This non-provisional patent application is a continuation of U.S. patent application Ser. No. 14/082,071, filed Nov. 15, 2013, which is a continuation-in-part of U.S. patent application Ser. No. 14/080,717, filed Nov. 14, 2013, pending, and a continuation-in-part of U.S. patent application Ser. No. 14/080,725, filed Nov. 14, 2013, pending, and further claims priority under 35 U.S.C. §119(e) to U.S. Provisional Patent application, Ser. No. 61/882,403, filed Sep. 25, 2013, the disclosures of which are incorporated by reference.

FIELD

[0002] This application relates in general to electrocardiographic monitoring and, in particular, to remote interfacing of an extended wear electrocardiography and physiological sensor monitor.

BACKGROUND

[0003] The heart emits electrical signals as a by-product of the propagation of the action potentials that trigger depolarization of heart fibers. An electrocardiogram (ECG) measures and records such electrical potentials to visually depict the electrical activity of the heart over time. Conventionally, a standardized set format 12-lead configuration is used by an ECG machine to record cardiac electrical signals from well-established traditional chest locations. Electrodes at the end of each lead are placed on the skin over the anterior thoracic region of the patient's body to the lower right and to the lower left of the sternum, on the left anterior chest, and on the limbs. Sensed cardiac electrical activity is represented by PQRSTU waveforms that can be interpreted post-ECG recordation to derive heart rate and physiology. The P-wave represents atrial electrical activity. The QRSTU components represent ventricular electrical activity.

[0004] An ECG is a tool used by physicians to diagnose heart problems and other potential health concerns. An ECG is a snapshot of heart function, typically recorded over 12 seconds, that can help diagnose rate and regularity of heartbeats, effect of drugs or cardiac devices, including pacemakers and implantable cardioverter-defibrillators (ICDs), and whether a patient has heart disease. ECGs are used in-clinic during appointments, and, as a result, are limited to recording only those heart-related aspects present at the time of recording. Sporadic conditions that may not show up during a spot ECG recording require other means to diagnose them. These disorders include fainting or syncope; rhythm disorders, such as tachyarrhythmias and bradyarrhythmias; apneic episodes; and other cardiac and related disorders. Thus, an ECG only provides a partial picture and can be insufficient for complete patient diagnosis of many cardiac disorders.

[0005] Diagnostic efficacy can be improved, when appropriate, through the use of long-term extended ECG monitoring. Recording sufficient ECG and related physiology over an extended period is challenging, and often essential to enabling a physician to identify events of potential concern. A 30-day observation period is considered the

“gold standard” of ECG monitoring, yet achieving a 30-day observation day period has proven unworkable because such ECG monitoring systems are arduous to employ, cumbersome to the patient, and excessively costly. Ambulatory monitoring in-clinic is implausible and impracticable. Nevertheless, if a patient's ECG could be recorded in an ambulatory setting, thereby allowing the patient to engage in activities of daily living, the chances of acquiring meaningful information and capturing an abnormal event while the patient is engaged in normal activities becomes more likely to be achieved.

[0006] For instance, the long-term wear of ECG electrodes is complicated by skin irritation and the inability ECG electrodes to maintain continual skin contact after a day or two. Moreover, time, dirt, moisture, and other environmental contaminants, as well as perspiration, skin oil, and dead skin cells from the patient's body, can get between an ECG electrode, the non-conductive adhesive used to adhere the ECG electrode, and the skin's surface. All of these factors adversely affect electrode adhesion and the quality of cardiac signal recordings. Furthermore, the physical movements of the patient and their clothing impart various compressional, tensile, and torsional forces on the contact point of an ECG electrode, especially over long recording times, and an inflexibly fastened ECG electrode will be prone to becoming dislodged. Moreover, dislodgment may occur unbeknownst to the patient, making the ECG recordings worthless. Further, some patients may have skin that is susceptible to itching or irritation, and the wearing of ECG electrodes can aggravate such skin conditions. Thus, a patient may want or need to periodically remove or replace ECG electrodes during a long-term ECG monitoring period, whether to replace a dislodged electrode, reestablish better adhesion, alleviate itching or irritation, allow for cleansing of the skin, allow for showering and exercise, or for other purpose. Such replacement or slight alteration in electrode location actually facilitates the goal of recording the ECG signal for long periods of time.

[0007] Conventionally, Holter monitors are widely used for long-term extended ECG monitoring. Typically, they are used for only 24-48 hours. A typical Holter monitor is a wearable and portable version of an ECG that include cables for each electrode placed on the skin and a separate battery-powered ECG recorder. The cable and electrode combination (or leads) are placed in the anterior thoracic region in a manner similar to what is done with an in-clinic standard ECG machine. The duration of a Holter monitoring recording depends on the sensing and storage capabilities of the monitor, as well as battery life. A “looping” Holter monitor (or event) can operate for a longer period of time by overwriting older ECG tracings, thence “recycling” storage in favor of extended operation, yet at the risk of losing event data. Although capable of extended ECG monitoring, Holter monitors are cumbersome, expensive and typically only available by medical prescription, which limits their usability. Further, the skill required to properly place the electrodes on the patient's chest hinders or precludes a patient from replacing or removing the precordial leads and usually involves moving the patient from the physician office to a specialized center within the hospital or clinic.

[0008] The ZIO XT Patch and ZIO Event Card devices, manufactured by iRhythm Tech., Inc., San Francisco, Calif., are wearable stick-on monitoring devices that are typically worn on the upper left pectoral region to respectively

provide continuous and looping ECG recording. The location is used to simulate surgically implanted monitors. Both of these devices are prescription-only and for single patient use. The ZIO XT Patch device is limited to a 14-day monitoring period, while the electrodes only of the ZIO Event Card device can be worn for up to 30 days. The ZIO XT Patch device combines both electronic recordation components, including battery, and physical electrodes into a unitary assembly that adheres to the patient's skin. The ZIO XT Patch device uses adhesive sufficiently strong to support the weight of both the monitor and the electrodes over an extended period of time and to resist disadherence from the patient's body, albeit at the cost of disallowing removal or relocation during the monitoring period. Moreover, throughout monitoring, the battery is continually depleted and battery capacity can potentially limit overall monitoring duration. The ZIO Event Card device is a form of downsized Holter monitor with a recorder component that must be removed temporarily during baths or other activities that could damage the non-waterproof electronics. Both devices represent compromises between length of wear and quality of ECG monitoring, especially with respect to ease of long term use, female-friendly fit, and quality of atrial (P-wave) signals.

[0009] In addition, with the advent of wireless communications and wearable computing, other types of personal ambulatory monitors, of varying degrees of sophistication, have become increasingly available. For example, adherents to the so-called "Quantified Self" movement combine wearable sensors and wearable computing to self-track activities of their daily lives, including inputs, states, and performance. The Nike+ FuelBand, manufactured by Nike Inc., Beaverton, Oreg., for instance, provides an activity tracker that is worn on the wrist and allows the wearer to temporally track the number of foot steps taken each day and an estimation of the calories burned. The activity tracker can interface with a smart phone device to allow a wearer to monitor their progress towards a fitness goal. Such quantified physiology, however, is typically tracked for only the personal use of the wearer and is not time-correlated to physician-supervised monitoring.

[0010] Therefore, a need remains for an extended wear continuously recording ECG monitor practicably capable of being worn for a long period of time in both men and women and capable of recording atrial signals reliably.

[0011] A further need remains for facilities to integrate wider-ranging physiological and "life tracking"-type data into long-term ECG and physiological data monitoring.

SUMMARY

[0012] Physiological monitoring can be provided through a wearable monitor that includes two components, a flexible extended wear electrode patch and a removable reusable monitor recorder. The wearable monitor sits centrally (in the midline) on the patient's chest along the sternum oriented top-to-bottom. The placement of the wearable monitor in a location at the sternal midline (or immediately to either side of the sternum), with its unique narrow "hourglass"-like shape, benefits long-term extended wear by removing the requirement that ECG electrodes be continually placed in the same spots on the skin throughout the monitoring period. Instead, the patient is free to place an electrode patch anywhere within the general region of the sternum, the area most likely to record high quality atrial signals or P-waves.

The wearable monitor can also interoperate wirelessly with other wearable physiology and activity sensors and with wearable or mobile communications devices, including so-called "smart phones," to download monitoring data either in real-time or in batches. The monitor recorder can also be equipped with a wireless transceiver to either provide data or other information to, or receive data or other information from, an interfacing wearable physiology and activity sensor, or wearable or mobile communications devices for relay to a further device, such as a server, analysis, or other purpose.

[0013] One embodiment provides a remotely-interfaceable extended wear electrocardiography and physiological sensor monitor recorder. A sealed housing forms on a bottom surface a cavity shaped to accommodate an upward projection of a battery compartment formed on a non-conductive receptacle of a disposable extended wear electrode patch and includes a set of electrical contacts that protrude from the bottom surface and are arranged in alignment with electrical pads provided on the non-conductive receptacle. Electronic circuitry is provided within the sealed housing and includes an externally-powered micro-controller operable to execute under micro programmable control. An electrocardiographic front end circuit is electrically interfaced to the micro-controller. A wireless transceiver electrically interfaces with the micro-controller and externally-powered flash memory is electrically interfaced with the micro-controller and operable to store samples of the electrocardiographic signals.

[0014] A further embodiment provides a remotely-interfaceable extended wear electrocardiography and physiological sensor monitor. A disposable extended wear electrode patch includes a flexible backing formed of an elongated strip of stretchable material with a narrow longitudinal midsection and, on each end, a contact surface is at least partially coated with an adhesive dressing provided as a crimp relief. A pair of electrocardiographic electrodes are conductively exposed on the contact surface of each end of the elongated strip, respectively. A non-conductive receptacle is adhered to an outward-facing surface of the elongated strip and includes a plurality of electrical pads. A flexible circuit is affixed on each end of the elongated strip as a strain relief and includes a pair of circuit traces electrically coupled to the pair of the electrocardiographic electrodes and a pair of the electrical pads. At least one of the circuit traces is adapted to extend along the narrow longitudinal midsection to serve as the strain relief. A reusable electrocardiography monitor includes a sealed housing that has formed on a bottom surface a cavity shaped to accommodate an upward projection of a battery compartment formed on a non-conductive receptacle of a disposable extended wear electrode patch and includes a set of electrical contacts that protrude from the bottom surface and are arranged in alignment with the electrical pads provided on the non-conductive receptacle. The reusable electrocardiography monitor includes electronic circuitry including a micro-controller operable to execute under micro programmable control and electrically interfaced to an electrocardiographic front end circuit that is operable to sense electrocardiographic signals through the electrocardiographic electrodes via the pair of the electrical pads. A wireless transceiver is electrically interfaced with the micro-controller and operable to wirelessly interface with an external wireless-enabled device to communicate samples of the electrocardiographic signals. A flash memory is electrically

interfaced with the micro-controller and operable to store the samples of the electrocardiographic signals.

[0015] The monitoring patch is especially suited to the female anatomy. The narrow longitudinal midsection can fit nicely within the intermammary cleft of the breasts without inducing discomfort, whereas conventional patch electrodes are wide and, if adhesed between the breasts, would cause chafing, irritation, frustration, and annoyance, leading to low patient compliance.

[0016] The foregoing aspects enhance ECG monitoring performance and quality, facilitating long-term ECG recording, critical to accurate arrhythmia diagnosis.

[0017] In addition, the foregoing aspects enhance comfort in women (and certain men), but not irritation of the breasts, by placing the monitoring patch in the best location possible for optimizing the recording of cardiac signals from the atrium, another feature critical to proper arrhythmia diagnosis.

[0018] Finally, the foregoing aspects as relevant to monitoring are equally applicable to recording other physiological measures, such as temperature, respiratory rate, blood sugar, oxygen saturation, and blood pressure, as well as other measures of body chemistry and physiology.

[0019] Still other embodiments will become readily apparent to those skilled in the art from the following detailed description, wherein are described embodiments by way of illustrating the best mode contemplated. As will be realized, other and different embodiments are possible and the embodiments' several details are capable of modifications in various obvious respects, all without departing from their spirit and the scope. Accordingly, the drawings and detailed description are to be regarded as illustrative in nature and not as restrictive.

BRIEF DESCRIPTION OF THE DRAWINGS

[0020] FIGS. 1 and 2 are diagrams showing, by way of examples, an extended wear electrocardiography and physiological sensor monitor respectively fitted to the sternal region of a female patient and a male patient.

[0021] FIG. 3 is a functional block diagram showing a system for remote interfacing of an extended wear electrocardiography and physiological sensor monitor in accordance with one embodiment.

[0022] FIG. 4 is a perspective view showing an extended wear electrode patch with a monitor recorder inserted.

[0023] FIG. 5 is a perspective view showing the monitor recorder of FIG. 4.

[0024] FIG. 6 is a perspective view showing the extended wear electrode patch of FIG. 4 without a monitor recorder inserted.

[0025] FIG. 7 is a bottom plan view of the monitor recorder of FIG. 4.

[0026] FIG. 8 is a top view showing the flexible circuit of the extended wear electrode patch of FIG. 4 when mounted above the flexible backing.

[0027] FIG. 9 is a functional block diagram showing the component architecture of the circuitry of the monitor recorder of FIG. 4.

[0028] FIG. 10 is a functional block diagram showing the circuitry of the extended wear electrode patch of FIG. 4.

[0029] FIG. 11 is a flow diagram showing a monitor recorder-implemented method for monitoring ECG data for use in the monitor recorder of FIG. 4.

[0030] FIG. 12 is a graph showing, by way of example, a typical ECG waveform.

[0031] FIG. 13 is a flow diagram showing a method for offloading and converting ECG and other physiological data from an extended wear electrocardiography and physiological sensor monitor in accordance with one embodiment.

DETAILED DESCRIPTION

[0032] Physiological monitoring can be provided through a wearable monitor that includes two components, a flexible extended wear electrode patch and a removable reusable monitor recorder. FIGS. 1 and 2 are diagrams showing, by way of examples, an extended wear electrocardiography and physiological sensor monitor 12, including a monitor recorder 14 in accordance with one embodiment, respectively fitted to the sternal region of a female patient 10 and a male patient 11. The wearable monitor 12 sits centrally (in the midline) on the patient's chest along the sternum 13 oriented top-to-bottom with the monitor recorder 14 preferably situated towards the patient's head. In a further embodiment, the orientation of the wearable monitor 12 can be corrected post-monitoring, as further described infra. The electrode patch 15 is shaped to fit comfortably and conformal to the contours of the patient's chest approximately centered on the sternal midline 16 (or immediately to either side of the sternum 13). The distal end of the electrode patch 15 extends towards the Xiphoid process and, depending upon the patient's build, may straddle the region over the Xiphoid process. The proximal end of the electrode patch 15, located under the monitor recorder 14, is below the manubrium and, depending upon patient's build, may straddle the region over the manubrium.

[0033] The placement of the wearable monitor 12 in a location at the sternal midline 16 (or immediately to either side of the sternum 13) significantly improves the ability of the wearable monitor 12 to cutaneously sense cardiac electric signals, particularly the P-wave (or atrial activity) and, to a lesser extent, the QRS interval signals in the ECG waveforms that indicate ventricular activity, while simultaneously facilitating comfortable long-term wear for many weeks. The sternum 13 overlies the right atrium of the heart and the placement of the wearable monitor 12 in the region of the sternal midline 13 puts the ECG electrodes of the electrode patch 15 in a location better adapted to sensing and recording P-wave signals than other placement locations, say, the upper left pectoral region or lateral thoracic region or the limb leads. In addition, placing the lower or inferior pole (ECG electrode) of the electrode patch 15 over (or near) the Xiphoid process facilitates sensing of ventricular activity and provides superior recordation of the QRS interval.

[0034] When operated standalone, the monitor recorder 14 of the extended wear electrocardiography and physiological sensor monitor 12 senses and records the patient's ECG data into an onboard memory. In addition, the wearable monitor 12 can interoperate with other devices. FIG. 3 is a functional block diagram showing a system 120 for remote interfacing of an extended wear electrocardiography and physiological sensor monitor 12 in accordance with one embodiment. The monitor recorder 14 is a reusable component that can be fitted during patient monitoring into a non-conductive receptacle provided on the electrode patch 15, as further described infra with reference to FIG. 4, and later removed for offloading of stored ECG data or to receive revised programming. The monitor recorder 14 can then be connected

to a download station 125, which could be a programmer or other device that permits the retrieval of stored ECG monitoring data, execution of diagnostics on or programming of the monitor recorder 14, or performance of other functions. The monitor recorder 14 has a set of electrical contacts (not shown) that enable the monitor recorder 14 to physically interface to a set of terminals 128 on a paired receptacle 127 of the download station 125. In turn, the download station 125 executes a communications or offload program 126 (“Offload”) or similar program that interacts with the monitor recorder 14 via the physical interface to retrieve the stored ECG monitoring data. The download station 125 could be a server, personal computer, tablet or handheld computer, smart mobile device, or purpose-built programmer designed specific to the task of interfacing with a monitor recorder 14. Still other forms of download station 125 are possible.

[0035] Upon retrieving stored ECG monitoring data from a monitor recorder 14, middleware first operates on the retrieved data to adjust the ECG capture quality, as necessary, and to convert the retrieved data into a format suitable for use by third party post-monitoring analysis software, as further described infra with reference to FIG. 13. The formatted data can then be retrieved from the download station 125 over a hard link 135 using a control program 137 (“Ctl”) or analogous application executing on a personal computer 136 or other connectable computing device, via a communications link (not shown), whether wired or wireless, or by physical transfer of storage media (not shown). The personal computer 136 or other connectable device may also execute middleware that converts ECG data and other information into a format suitable for use by a third-party post-monitoring analysis program, as further described infra with reference to FIG. 13. Note that formatted data stored on the personal computer 136 would have to be maintained and safeguarded in the same manner as electronic medical records (EMRs) 134 in the secure database 124, as further discussed infra. In a further embodiment, the download station 125 is able to directly interface with other devices over a computer communications network 121, which could be some combination of a local area network and a wide area network, including the Internet, over a wired or wireless connection.

[0036] A client-server model could be used to employ a server 122 to remotely interface with the download station 125 over the network 121 and retrieve the formatted data or other information. The server 122 executes a patient management program 123 (“Mgt”) or similar application that stores the retrieved formatted data and other information in a secure database 124 cataloged in that patient’s EMRs 134. In addition, the patient management program 123 could manage a subscription service that authorizes a monitor recorder 14 to operate for a set period of time or under pre-defined operational parameters.

[0037] The patient management program 123, or other trusted application, also maintains and safeguards the secure database 124 to limit access to patient EMRs 134 to only authorized parties for appropriate medical or other uses, such as mandated by state or federal law, such as under the Health Insurance Portability and Accountability Act (HIPAA) or per the European Union’s Data Protection Directive. For example, a physician may seek to review and evaluate his patient’s ECG monitoring data, as securely stored in the secure database 124. The physician would

execute an application program 130 (“Pgm”), such as a post-monitoring ECG analysis program, on a personal computer 129 or other connectable computing device, and, through the application 130, coordinate access to his patient’s EMRs 134 with the patient management program 123. Other schemes and safeguards to protect and maintain the integrity of patient EMRs 134 are possible.

[0038] The wearable monitor 12 can interoperate wirelessly with other wearable physiology and activity sensors 131 and with wearable or mobile communications devices 133. Wearable physiology and activity sensors 131 encompass a wide range of wirelessly interconnectable devices that measure or monitor data physical to the patient’s body, such as heart rate, temperature, blood pressure, and so forth; physical states, such as movement, sleep, footsteps, and the like; and performance, including calories burned or estimated blood glucose level. These devices originate both within the medical community to sense and record traditional medical physiology that could be useful to a physician in arriving at a patient diagnosis or clinical trajectory, as well as from outside the medical community, from, for instance, sports or lifestyle product companies who seek to educate and assist individuals with self-quantifying interests.

[0039] Frequently, wearable physiology and activity sensors 131 are capable of wireless interfacing with wearable or mobile communications devices 133, particularly smart mobile devices, including so-called “smart phones,” to download monitoring data either in real-time or in batches. The wearable or mobile communications device 133 executes an application (“App”) that can retrieve the data collected by the wearable physiology and activity sensor 131 and evaluate the data to generate information of interest to the wearer, such as an estimation of the effectiveness of the wearer’s exercise efforts. Still other wearable or mobile communications device 133 functions on the collected data are possible.

[0040] The wearable or mobile communications devices 133 could also serve as a conduit for providing the data collected by the wearable physiology and activity sensor 131 to a server 122, or, similarly, the wearable physiology and activity sensor 131 could itself directly provide the collected data to the server 122. The server 122 could then merge the collected data into the wearer’s EMRs 134 in the secure database 124, if appropriate (and permissible), or the server 122 could perform an analysis of the collected data, perhaps based by comparison to a population of like wearers of the wearable physiology and activity sensor 131. Still other server 122 functions on the collected data are possible.

[0041] Finally, the monitor recorder 14 can also be equipped with a wireless transceiver, as further described infra with reference to FIGS. 9 and 10. Thus, when wireless-enabled, both wearable physiology and activity sensors 131 and wearable or mobile communications devices 133 could wirelessly interface with the monitor recorder 14, which could either provide data or other information to, or receive data or other information from an interfacing device for relay to a further device, such as the server 122, analysis, or other purpose. In addition, the monitor recorder 14 could wirelessly interface directly with the server 122, personal computer 129, or other computing device connectable over the network 121, when the monitor recorder 14 is appropriately equipped for interfacing with such devices. Still other types of remote interfacing of the monitor recorder 14 are possible.

[0042] During use, the electrode patch 15 is first adhered to the skin along the sternal midline 16 (or immediately to either side of the sternum 13). A monitor recorder 14 is then snapped into place on the electrode patch 15 to initiate ECG monitoring. FIG. 4 is a perspective view showing an extended wear electrode patch 15 with a monitor recorder 14 in accordance with one embodiment inserted. The body of the electrode patch 15 is preferably constructed using a flexible backing 20 formed as an elongated strip 21 of wrap knit or similar stretchable material with a narrow longitudinal mid-section 23 evenly tapering inward from both sides. A pair of cut-outs 22 between the distal and proximal ends of the electrode patch 15 create a narrow longitudinal midsection 23 or "isthmus" and defines an elongated "hour-glass"-like shape, when viewed from above.

[0043] The electrode patch 15 incorporates features that significantly improve wearability, performance, and patient comfort throughout an extended monitoring period. During wear, the electrode patch 15 is susceptible to pushing, pulling, and torquing movements, including compressional and torsional forces when the patient bends forward, and tensile and torsional forces when the patient leans backwards. To counter these stress forces, the electrode patch 15 incorporates strain and crimp reliefs, such as described in commonly-assigned U.S. patent application, entitled "Extended Wear Electrocardiography Patch," Ser. No. 14/080,717, filed Nov. 14, 2013, pending, the disclosure of which is incorporated by reference. In addition, the cut-outs 22 and longitudinal midsection 23 help minimize interference with and discomfort to breast tissue, particularly in women (and gynecomastic men). The cut-outs 22 and longitudinal midsection 23 further allow better conformity of the electrode patch 15 to sternal bowing and to the narrow isthmus of flat skin that can occur along the bottom of the intermammary cleft between the breasts, especially in buxom women. The cut-outs 22 and longitudinal midsection 23 help the electrode patch 15 fit nicely between a pair of female breasts in the intermammary cleft. Still other shapes, cut-outs and conformities to the electrode patch 15 are possible.

[0044] The monitor recorder 14 removably and reusably snaps into an electrically non-conductive receptacle 25 during use. The monitor recorder 14 contains electronic circuitry for recording and storing the patient's electrocardiography as sensed via a pair of ECG electrodes provided on the electrode patch 15, such as described in commonly-assigned U.S. patent application, entitled "Extended Wear Ambulatory Electrocardiography and Physiological Sensor Monitor," Ser. No. 14/080,725, filed Nov. 14, 2013, pending, the disclosure which is incorporated by reference. The non-conductive receptacle 25 is provided on the top surface of the flexible backing 20 with a retention catch 26 and tension clip 27 molded into the non-conductive receptacle 25 to conformably receive and securely hold the monitor recorder 14 in place.

[0045] The monitor recorder 14 includes a sealed housing that snaps into place in the non-conductive receptacle 25. FIG. 5 is a perspective view showing the monitor recorder 14 of FIG. 4. The sealed housing 50 of the monitor recorder 14 intentionally has a rounded isosceles trapezoidal-like shape 52, when viewed from above, such as described in commonly-assigned U.S. Design patent application, entitled "Electrocardiography Monitor," Ser. No. 29/472,046, filed Nov. 7, 2013, pending, the disclosure of which is incorpo-

rated by reference. The edges 51 along the top and bottom surfaces are rounded for patient comfort. The sealed housing 50 is approximately 47 mm long, 23 mm wide at the widest point, and 7 mm high, excluding a patient-operable tactile-feedback button 55. The sealed housing 50 can be molded out of polycarbonate, ABS, or an alloy of those two materials. The button 55 is waterproof and the button's top outer surface is molded silicon rubber or similar soft pliable material. A retention detent 53 and tension detent 54 are molded along the edges of the top surface of the housing 50 to respectively engage the retention catch 26 and the tension clip 27 molded into non-conductive receptacle 25. Other shapes, features, and conformities of the sealed housing 50 are possible.

[0046] The electrode patch 15 is intended to be disposable. The monitor recorder 14, however, is reusable and can be transferred to successive electrode patches 15 to ensure continuity of monitoring. The placement of the wearable monitor 12 in a location at the sternal midline 16 (or immediately to either side of the sternum 13) benefits long-term extended wear by removing the requirement that ECG electrodes be continually placed in the same spots on the skin throughout the monitoring period. Instead, the patient is free to place an electrode patch 15 anywhere within the general region of the sternum 13.

[0047] As a result, at any point during ECG monitoring, the patient's skin is able to recover from the wearing of an electrode patch 15, which increases patient comfort and satisfaction, while the monitor recorder 14 ensures ECG monitoring continuity with minimal effort. A monitor recorder 14 is merely unsnapped from a worn out electrode patch 15, the worn out electrode patch 15 is removed from the skin, a new electrode patch 15 is adhered to the skin, possibly in a new spot immediately adjacent to the earlier location, and the same monitor recorder 14 is snapped into the new electrode patch 15 to reinitiate and continue the ECG monitoring.

[0048] During use, the electrode patch 15 is first adhered to the skin in the sternal region. FIG. 6 is a perspective view showing the extended wear electrode patch 15 of FIG. 4 without a monitor recorder 14 inserted. A flexible circuit 32 is adhered to each end of the flexible backing 20. A distal circuit trace 33 and a proximal circuit trace (not shown) electrically couple ECG electrodes (not shown) to a pair of electrical pads 34. The electrical pads 34 are provided within a moisture-resistant seal 35 formed on the bottom surface of the non-conductive receptacle 25. When the monitor recorder 14 is securely received into the non-conductive receptacle 25, that is, snapped into place, the electrical pads 34 interface to electrical contacts (not shown) protruding from the bottom surface of the monitor recorder 14, and the moisture-resistant seal 35 enables the monitor recorder 14 to be worn at all times, even during bathing or other activities that could expose the monitor recorder 14 to moisture.

[0049] In addition, a battery compartment 36 is formed on the bottom surface of the non-conductive receptacle 25, and a pair of battery leads (not shown) electrically interface the battery to another pair of the electrical pads 34. The battery contained within the battery compartment 35 can be replaceable, rechargeable or disposable.

[0050] The monitor recorder 14 draws power externally from the battery provided in the non-conductive receptacle 25, thereby uniquely obviating the need for the monitor recorder 14 to carry a dedicated power source. FIG. 7 is a

bottom plan view of the monitor recorder **14** of FIG. **4**. A cavity **58** is formed on the bottom surface of the sealed housing **50** to accommodate the upward projection of the battery compartment **36** from the bottom surface of the non-conductive receptacle **25**, when the monitor recorder **14** is secured in place on the non-conductive receptacle **25**. A set of electrical contacts **56** protrude from the bottom surface of the sealed housing **50** and are arranged in alignment with the electrical pads **34** provided on the bottom surface of the non-conductive receptacle **25** to establish electrical connections between the electrode patch **15** and the monitor recorder **14**. In addition, a seal coupling **57** circumferentially surrounds the set of electrical contacts **56** and securely mates with the moisture-resistant seal **35** formed on the bottom surface of the non-conductive receptacle **25**.

[0051] The placement of the flexible backing **20** on the sternal midline **16** (or immediately to either side of the sternum **13**) also helps to minimize the side-to-side movement of the wearable monitor **12** in the left- and right-handed directions during wear. To counter the dislodgment of the flexible backing **20** due to compressional and torsional forces, a layer of non-irritating adhesive, such as hydrocolloid, is provided at least partially on the underside, or contact, surface of the flexible backing **20**, but only on the distal end **30** and the proximal end **31**. As a result, the underside, or contact surface of the longitudinal midsection **23** does not have an adhesive layer and remains free to move relative to the skin. Thus, the longitudinal midsection **23** forms a crimp relief that respectively facilitates compression and twisting of the flexible backing **20** in response to compressional and torsional forces. Other forms of flexible backing crimp reliefs are possible.

[0052] Unlike the flexible backing **20**, the flexible circuit **32** is only able to bend and cannot stretch in a planar direction. The flexible circuit **32** can be provided either above or below the flexible backing **20**. FIG. **8** is a top view showing the flexible circuit **32** of the extended wear electrode patch **15** of FIG. **4** when mounted above the flexible backing **20**. A distal ECG electrode **38** and proximal ECG electrode **39** are respectively coupled to the distal and proximal ends of the flexible circuit **32**. A strain relief **40** is defined in the flexible circuit **32** at a location that is partially underneath the battery compartment **36** when the flexible circuit **32** is affixed to the flexible backing **20**. The strain relief **40** is laterally extendable to counter dislodgment of the ECG electrodes **38**, **39** due to tensile and torsional forces. A pair of strain relief cutouts **41** partially extend transversely from each opposite side of the flexible circuit **32** and continue longitudinally towards each other to define in 'S'-shaped pattern, when viewed from above. The strain relief respectively facilitates longitudinal extension and twisting of the flexible circuit **32** in response to tensile and torsional forces. Other forms of circuit board strain relief are possible.

[0053] ECG monitoring and other functions performed by the monitor recorder **14** are provided through a micro controlled architecture. FIG. **9** is a functional block diagram showing the component architecture of the circuitry **60** of the monitor recorder **14** of FIG. **4**. The circuitry **60** is externally powered through a battery provided in the non-conductive receptacle **25** (shown in FIG. **6**). Both power and raw ECG signals, which originate in the pair of ECG electrodes **38**, **39** (shown in FIG. **8**) on the distal and proximal ends of the electrode patch **15**, are received

through an external connector **65** that mates with a corresponding physical connector on the electrode patch **15**. The external connector **65** includes the set of electrical contacts **56** that protrude from the bottom surface of the sealed housing **50** and which physically and electrically interface with the set of pads **34** provided on the bottom surface of the non-conductive receptacle **25**. The external connector includes electrical contacts **56** for data download, micro-controller communications, power, analog inputs, and a peripheral expansion port. The arrangement of the pins on the electrical connector **65** of the monitor recorder **14** and the device into which the monitor recorder **14** is attached, whether an electrode patch **15** or download station (not shown), follow the same electrical pin assignment convention to facilitate interoperability. The external connector **65** also serves as a physical interface to a download station that permits the retrieval of stored ECG monitoring data, communication with the monitor recorder **14**, and performance of other functions.

[0054] Operation of the circuitry **60** of the monitor recorder **14** is managed by a microcontroller **61**. The microcontroller **61** includes a program memory unit containing internal flash memory that is readable and writeable. The internal flash memory can also be programmed externally. The micro-controller **61** draws power externally from the battery provided on the electrode patch **15** via a pair of the electrical contacts **56**. The microcontroller **61** connects to the ECG front end circuit **63** that measures raw cutaneous electrical signals and generates an analog ECG signal representative of the electrical activity of the patient's heart over time.

[0055] The circuitry **60** of the monitor recorder **14** also includes a flash memory **62**, which the micro-controller **61** uses for storing ECG monitoring data and other physiology and information. The flash memory **62** also draws power externally from the battery provided on the electrode patch **15** via a pair of the electrical contacts **56**. Data is stored in a serial flash memory circuit, which supports read, erase and program operations over a communications bus. The flash memory **62** enables the microcontroller **61** to store digitized ECG data. The communications bus further enables the flash memory **62** to be directly accessed externally over the external connector **65** when the monitor recorder **14** is interfaced to a download station.

[0056] The circuitry **60** of the monitor recorder **14** further includes an actigraphy sensor **64** implemented as a 3-axis accelerometer. The accelerometer may be configured to generate interrupt signals to the microcontroller **61** by independent initial wake up and free fall events, as well as by device position. In addition, the actigraphy provided by the accelerometer can be used during post-monitoring analysis to correct the orientation of the monitor recorder **14** if, for instance, the monitor recorder **14** has been inadvertently installed upside down, that is, with the monitor recorder **14** oriented on the electrode patch **15** towards the patient's feet, as well as for other event occurrence analyses, such as described in commonly-assigned U.S. Patent Application Publication No. 2015/0087923, issued Mar. 26, 2016, the disclosure of which is incorporated by reference.

[0057] The circuitry **60** of the monitor recorder **14** includes a wireless transceiver **69** that can provides wireless interfacing capabilities. The wireless transceiver **69** also draws power externally from the battery provided on the electrode patch **15** via a pair of the electrical contacts **56**.

The wireless transceiver **69** can be implemented using one or more forms of wireless communications, including the IEEE 802.11 computer communications standard, that is Wi-Fi; the 4G mobile phone mobile communications standard; the Bluetooth data exchange standard; or other wireless communications or data exchange standards and protocols. The type of wireless interfacing capability could limit the range of interoperability of the monitor recorder **14**; for instance, Bluetooth-based implementations are designed for low power consumption with a short communications range.

[0058] The microcontroller **61** includes an expansion port that also utilizes the communications bus. External devices, separately drawing power externally from the battery provided on the electrode patch **15** or other source, can interface to the microcontroller **61** over the expansion port in half duplex mode. For instance, an external physiology sensor can be provided as part of the circuitry **60** of the monitor recorder **14**, or can be provided on the electrode patch **15** with communication with the microcontroller **61** provided over one of the electrical contacts **56**. The physiology sensor can include an SpO₂ sensor, blood pressure sensor, temperature sensor, respiratory rate sensor, glucose sensor, airflow sensor, volumetric pressure sensing, or other types of sensor or telemetric input sources. For instance, the integration of an airflow sensor is described in commonly-assigned U.S. Pat. No. 9,364,155, issued Jun. 14, 2016, the disclosure which is incorporated by reference.

[0059] Finally, the circuitry **60** of the monitor recorder **14** includes patient-interfaceable components, including a tactile feedback button **66**, which a patient can press to mark events or to perform other functions, and a buzzer **67**, such as a speaker, magnetic resonator or piezoelectric buzzer. The buzzer **67** can be used by the microcontroller **61** to output feedback to a patient such as to confirm power up and initiation of ECG monitoring. Still other components as part of the circuitry **60** of the monitor recorder **14** are possible.

[0060] While the monitor recorder **14** operates under micro control, most of the electrical components of the electrode patch **15** operate passively. FIG. **10** is a functional block diagram showing the circuitry **70** of the extended wear electrode patch **15** of FIG. **4**. The circuitry **70** of the electrode patch **15** is electrically coupled with the circuitry **60** of the monitor recorder **14** through an external connector **74**. The external connector **74** is terminated through the set of pads **34** provided on the bottom of the non-conductive receptacle **25**, which electrically mate to corresponding electrical contacts **56** protruding from the bottom surface of the sealed housing **50** to electrically interface the monitor recorder **14** to the electrode patch **15**.

[0061] The circuitry **70** of the electrode patch **15** performs three primary functions. First, a battery **71** is provided in a battery compartment formed on the bottom surface of the non-conductive receptacle **25**. The battery **71** is electrically interfaced to the circuitry **60** of the monitor recorder **14** as a source of external power. The unique provisioning of the battery **71** on the electrode patch **15** provides several advantages. First, the locating of the battery **71** physically on the electrode patch **15** lowers the center of gravity of the overall wearable monitor **12** and thereby helps to minimize shear forces and the effects of movements of the patient and clothing. Moreover, the housing **50** of the monitor recorder **14** is sealed against moisture and providing power externally avoids having to either periodically open the housing **50** for the battery replacement, which also creates the potential for

moisture intrusion and human error, or to recharge the battery, which can potentially take the monitor recorder **14** off line for hours at a time. In addition, the electrode patch **15** is intended to be disposable, while the monitor recorder **14** is a reusable component. Each time that the electrode patch **15** is replaced, a fresh battery is provided for the use of the monitor recorder **14**, which enhances ECG monitoring performance quality and duration of use. Finally, the architecture of the monitor recorder **14** is open, in that other physiology sensors or components can be added by virtue of the expansion port of the microcontroller **61**. Requiring those additional sensors or components to draw power from a source external to the monitor recorder **14** keeps power considerations independent of the monitor recorder **14**. Thus, a battery of higher capacity could be introduced when needed to support the additional sensors or components without effecting the monitor recorder's circuitry **60**.

[0062] Second, the pair of ECG electrodes **38, 39** respectively provided on the distal and proximal ends of the flexible circuit **32** are electrically coupled to the set of pads **34** provided on the bottom of the non-conductive receptacle **25** by way of their respective circuit traces **33, 37**. The signal ECG electrode **39** includes a protection circuit **72**, which is an inline resistor that protects the patient from excessive leakage current.

[0063] Last, in a further embodiment, the circuitry **70** of the electrode patch **15** includes a cryptographic circuit **73** to authenticate an electrode patch **15** for use with a monitor recorder **14**. The cryptographic circuit **73** includes a device capable of secure authentication and validation. The cryptographic device **73** ensures that only genuine, non-expired, safe, and authenticated electrode patches **15** are permitted to provide monitoring data to a monitor recorder **14**, such as described in commonly-assigned U.S. Patent Application Publication No. 2015/0087950, issued Mar. 26, 2015, the disclosure which is incorporated by reference.

[0064] In a further embodiment, the circuitry **70** of the electrode patch **15** includes a wireless transceiver **75**, in lieu of the including of the wireless transceiver **69** in the circuitry **60** of the monitor recorder **14**, which interfaces with the microcontroller **61** over the microcontroller's expansion port via the external connector **74**.

[0065] The monitor recorder **14** continuously monitors the patient's heart rate and physiology. FIG. **11** is a flow diagram showing a monitor recorder-implemented method **100** for monitoring ECG data for use in the monitor recorder **14** of FIG. **4**. Initially, upon being connected to the set of pads **34** provided with the non-conductive receptacle **25** when the monitor recorder **14** is snapped into place, the microcontroller **61** executes a power up sequence (step **101**). During the power up sequence, the voltage of the battery **71** is checked, the state of the flash memory **62** is confirmed, both in terms of operability check and available capacity, and microcontroller operation is diagnostically confirmed. In a further embodiment, an authentication procedure between the microcontroller **61** and the electrode patch **15** are also performed.

[0066] Following satisfactory completion of the power up sequence, an iterative processing loop (steps **102-109**) is continually executed by the microcontroller **61**. During each iteration (step **102**) of the processing loop, the ECG frontend **63** (shown in FIG. **9**) continually senses the cutaneous ECG electrical signals (step **103**) via the ECG electrodes **38, 29** and is optimized to maintain the integrity of the P-wave. A

sample of the ECG signal is read (step **104**) by the microcontroller **61** by sampling the analog ECG signal output front end **63**. FIG. **12** is a graph showing, by way of example, a typical ECG waveform **110**. The x-axis represents time in approximate units of tenths of a second. The y-axis represents cutaneous electrical signal strength in approximate units of millivolts. The P-wave **111** has a smooth, normally upward, that is, positive, waveform that indicates atrial depolarization. The QRS complex usually begins with the downward deflection of a Q wave **112**, followed by a larger upward deflection of an R-wave **113**, and terminated with a downward waveform of the S wave **114**, collectively representative of ventricular depolarization. The T wave **115** is normally a modest upward waveform, representative of ventricular repolarization, while the U wave **116**, often not directly observable, indicates the recovery period of the Purkinje conduction fibers.

[0067] Sampling of the R-to-R interval enables heart rate information derivation. For instance, the R-to-R interval represents the ventricular rate and rhythm, while the P-to-P interval represents the atrial rate and rhythm. Importantly, the PR interval is indicative of atrioventricular (AV) conduction time and abnormalities in the PR interval can reveal underlying heart disorders, thus representing another reason why the P-wave quality achievable by the extended wear ambulatory electrocardiography and physiological sensor monitor described herein is medically unique and important. The long-term observation of these ECG indicia, as provided through extended wear of the wearable monitor **12**, provides valuable insights to the patient's cardiac function and overall well-being.

[0068] Each sampled ECG signal, in quantized and digitized form, is temporarily staged in buffer (step **105**), pending compression preparatory to storage in the flash memory **62** (step **106**). Following compression, the compressed ECG digitized sample is again buffered (step **107**), then written to the flash memory **62** (step **108**) using the communications bus. Processing continues (step **109**), so long as the monitoring recorder **14** remains connected to the electrode patch **15** (and storage space remains available in the flash memory **62**), after which the processing loop is exited and execution terminates. Still other operations and steps are possible.

[0069] In a further embodiment, the monitor recorder **14** also continuously receives data from wearable physiology and activity sensors **131** and wearable or mobile communications devices **133** (shown in FIG. **3**). the data is received in a conceptually-separate execution thread as part of the iterative processing loop (steps **102-109**) continually executed by the microcontroller **61**. During each iteration (step **102**) of the processing loop, if wireless data is available (step **140**), a sample of the wireless is read (step **141**) by the microcontroller **61** and, if necessary, converted into a digital signal by the onboard ADC of the microcontroller **61**. Each wireless data sample, in quantized and digitized form, is temporarily staged in buffer (step **142**), pending compression preparatory to storage in the flash memory **62** (step **143**). Following compression, the compressed wireless data sample is again buffered (step **144**), then written to the flash memory **62** (step **145**) using the communications bus. Processing continues (step **109**), so long as the monitoring recorder **14** remains connected to the electrode patch **15** (and storage space remains available in the flash memory **62**), after which the processing loop is exited and execution terminates. Still other operations and steps are possible.

[0070] The monitor recorder **14** stores ECG data and other information in the flash memory **62** (shown in FIG. **9**) using a proprietary format that includes data compression. As a result, data retrieved from a monitor recorder **14** must first be converted into a format suitable for use by third party post-monitoring analysis software. FIG. **13** is a flow diagram showing a method **150** for offloading and converting ECG and other physiological data from an extended wear electrocardiography and physiological sensor monitor **12** in accordance with one embodiment. The method **150** can be implemented in software and execution of the software can be performed on a download station **125**, which could be a programmer or other device, or a computer system, including a server **122** or personal computer **129**, such as further described supra with reference to FIG. **3**, as a series of process or method modules or steps. For convenience, the method **150** will be described in the context of being performed by a personal computer **136** or other connectable computing device (shown in FIG. **3**) as middleware that converts ECG data and other information into a format suitable for use by a third-party post-monitoring analysis program. Execution of the method **150** by a computer system would be analogous mutatis mutandis.

[0071] Initially, the download station **125** is connected to the monitor recorder **14** (step **151**), such as by physically interfacing to a set of terminals **128** on a paired receptacle **127** or by wireless connection, if available. The data stored on the monitor recorder **14**, including ECG and physiological monitoring data, other recorded data, and other information are retrieved (step **152**) over a hard link **135** using a control program **137** ("Ctl") or analogous application executing on a personal computer **136** or other connectable computing device.

[0072] The data retrieved from the monitor recorder **14** is in a proprietary storage format and each datum of recorded ECG monitoring data, as well as any other physiological data or other information, must be converted, so that the data can be used by a third-party post-monitoring analysis program. Each datum of ECG monitoring data is converted by the middleware (steps **153-159**) in an iterative processing loop. During each iteration (step **153**), the ECG datum is read (step **154**) and, if necessary, the gain of the ECG signal is adjusted (step **155**) to compensate, for instance, for relocation or replacement of the electrode patch **15** during the monitoring period.

[0073] In addition, depending upon the configuration of the wearable monitor **12**, other physiological data (or other information), including patient events, such as a fall, peak activity level, sleep detection, Detection of patient activity levels and states, and so on, may be recorded along with the ECG monitoring data. For instance, actigraphy data may have been sampled by the actigraphy sensor **64** based on a sensed event occurrence, such as a sudden change in orientation due to the patient taking a fall. In response, the monitor recorder **14** will embed the actigraphy data samples into the stream of data, including ECG monitoring data, that is recorded to the flash memory **62** by the micro-controller **61**. Post-monitoring, the actigraphy data is temporally matched to the ECG data to provide the proper physiological context to the sensed event occurrence. As a result, the three-axis actigraphy signal is turned into an actionable event occurrence that is provided, through conversion by the middleware, to third party post-monitoring analysis programs, along with the ECG recordings contemporaneous to

the event occurrence. Other types of processing of the other physiological data (or other information) are possible.

[0074] Thus, during execution of the middleware, any other physiological data (or other information) that has been embedded into the recorded ECG monitoring data is read (step 156) and time-correlated to the time frame of the ECG signals that occurred at the time that the other physiological data (or other information) was noted (step 157). Finally, the ECG datum, signal gain adjusted, if appropriate, and other physiological data, if applicable and as time-correlated, are stored in a format suitable to the backend software (step 158) used in post-monitoring analysis.

[0075] In a further embodiment, the other physiological data, if apropos, is embedded within an unused ECG track. For example, the SCP-ENG standard allows multiple ECG channels to be recorded into a single ECG record. The monitor recorder 14, though, only senses one ECG channel. The other physiological data can be stored into an additional ECG channel, which would otherwise be zero-padded or altogether omitted. The backend software would then be able to read the other physiological data in context with the single channel of ECG monitoring data recorded by the monitor recorder 14, provided the backend software implemented changes necessary to interpret the other physiological data. Still other forms of embedding of the other physiological data with formatted ECG monitoring data, or of providing the other physiological data in a separate manner, are possible.

[0076] Processing continues (step 159) for each remaining ECG datum, after which the processing loop is exited and execution terminates. Still other operations and steps are possible.

[0077] While the invention has been particularly shown and described as referenced to the embodiments thereof, those skilled in the art will understand that the foregoing and other changes in form and detail may be made therein without departing from the spirit and scope.

What is claimed is:

1. A remotely-interfaceable extended wear electrocardiography and physiological sensor monitor recorder, comprising:

a sealed housing forming on a bottom surface a cavity shaped to accommodate an upward projection of a battery compartment formed on a non-conductive receptacle of a disposable extended wear electrode patch and comprising a set of electrical contacts that protrude from the bottom surface and are arranged in alignment with electrical pads provided on the non-conductive receptacle; and

electronic circuitry comprised within the sealed housing, comprising:

an externally-powered micro-controller operable to execute under micro programmable control;

an electrocardiographic front end circuit electrically interfaced to the micro-controller and operable to sense electrocardiographic signals through electrocardiographic electrodes provided on the disposable extended wear electrode patch;

a wireless transceiver electrically interfaced with the micro-controller and operable to wirelessly interface with an external wireless-enabled device to communicate samples of the electrocardiographic signals; and

externally-powered flash memory electrically interfaced with the micro-controller and operable to store the samples of the electrocardiographic signals.

2. An electrocardiography and physiological sensor monitor recorder according to claim 1, further comprising at least one of:

a seal coupling circumferentially surrounding the set of electrical contacts.

3. An electrocardiography and physiological sensor monitor recorder according to claim 2, wherein the seal coupling securely mates with a moisture-resistant seal formed on the non-conductive receptacle.

4. An electrocardiography and physiological sensor monitor recorder according to claim 1, further comprising:

a patient-operable tactile-feedback button provided on a top surface of the sealed housing.

5. An electrocardiography and physiological sensor monitor recorder according to claim 1, wherein a battery is provided in the battery compartment of the non-conductive receptacle of the extended wear electrode patch and powers the electronic circuitry.

6. An electrocardiography and physiological sensor monitor recorder according to claim 1, further comprising:

a feedback buzzer utilized by the microcontroller.

7. An electrocardiography and physiological sensor monitor recorder according to claim 1, further comprising:

an external physiological sensor provided with the circuitry and comprising at least one of an SpO₂ sensor, blood pressure sensor, temperature sensor, respiratory rate sensor, glucose sensor, airflow sensor, and volumetric pressure sensor.

8. An electrocardiography and physiological sensor monitor recorder according to claim 1, wherein the sealed housing comprises a rounded isosceles trapezoidal-like shape.

9. An electrocardiography and physiological sensor monitor recorder according to claim 1, further comprising:

a least one of a retention detent and a tension detent each molded along a top edge of a top surface of the sealed housing.

10. An electrocardiography and physiological sensor monitor recorder according to claim 1, wherein the retention detent and tension detent are shaped to engage respectively with a retention catch and a tension clip molded into the non-conductive receptacle.

11. A remotely-interfaceable extended wear electrocardiography and physiological sensor monitor, comprising:

a disposable extended wear electrode patch comprising:

a flexible backing formed of an elongated strip of stretchable material with a narrow longitudinal mid-section and, on each end, a contact surface at least partially coated with an adhesive dressing provided as a crimp relief;

a pair of electrocardiographic electrodes conductively exposed on the contact surface of each end of the elongated strip, respectively;

a non-conductive receptacle adhered to an outward-facing surface of the elongated strip and comprising a plurality of electrical pads; and

a flexible circuit affixed on each end of the elongated strip as a strain relief and comprising a pair of circuit traces electrically coupled to the pair of the electrocardiographic electrodes and a pair of the electrical pads, at least one of the circuit traces adapted to extend along the narrow longitudinal midsection to serve as the strain relief; and

a reusable electrocardiography monitor having a sealed housing forming on a bottom surface a cavity shaped to

- accommodate an upward projection of a battery compartment formed on a non-conductive receptacle of a disposable extended wear electrode patch and comprising a set of electrical contacts that protrude from the bottom surface and are arranged in alignment with the electrical pads provided on the non-conductive receptacle, wherein the reusable electrocardiography monitor comprises electronic circuitry, comprising:
- a micro-controller operable to execute under micro programmable control and electrically interfaced to an electrocardiographic front end circuit that is operable to sense electrocardiographic signals through the electrocardiographic electrodes via the pair of the electrical pads;
 - a wireless transceiver electrically interfaced with the micro-controller and operable to wirelessly interface with an external wireless-enabled device to communicate samples of the electrocardiographic signals; and
 - a flash memory electrically interfaced with the micro-controller and operable to store the samples of the electrocardiographic signals.
- 12.** An electrocardiography and physiological sensor monitor according to claim **11**, further comprising at least one of:
- a seal coupling circumferentially surrounding the set of electrical contacts.
- 13.** An electrocardiography and physiological sensor monitor according to claim **12**, wherein the seal coupling securely mates with a moisture-resistant seal formed on the non-conductive receptacle.
- 14.** An electrocardiography and physiological sensor monitor according to claim **11**, further comprising:

a patient-operable tactile-feedback button provided on a top surface of the sealed housing.

15. An electrocardiography and physiological sensor monitor according to claim **11**, wherein a battery is provided in the battery compartment of the non-conductive receptacle of the extended wear electrode patch and powers the electronic circuitry.

16. An electrocardiography and physiological sensor monitor according to claim **11**, further comprising:

- a feedback buzzer utilized by the microcontroller.

17. An electrocardiography and physiological sensor monitor according to claim **11**, further comprising:

- an external physiological sensor provided with the circuitry and comprising at least one of an SpO₂ sensor, blood pressure sensor, temperature sensor, respiratory rate sensor, glucose sensor, airflow sensor, and volumetric pressure sensor.

18. An electrocardiography and physiological sensor monitor according to claim **11**, wherein the sealed housing comprises a rounded isosceles trapezoidal-like shape.

19. An electrocardiography and physiological sensor monitor according to claim **11**, further comprising:

- a least one of a retention detent and a tension detent each molded along a top edge of a top surface of the sealed housing.

20. An electrocardiography and physiological sensor monitor according to claim **11**, wherein the retention detent and tension detent are shaped to engage respectively with a retention catch and a tension clip molded into the non-conductive receptacle.

* * * * *

专利名称(译)	扩展磨损心电图与生理传感器监测的远程接口		
公开(公告)号	US20160367164A1	公开(公告)日	2016-12-22
申请号	US15/256266	申请日	2016-09-02
[标]申请(专利权)人(译)	BARDY诊断		
申请(专利权)人(译)	BARDY诊断, INC		
当前申请(专利权)人(译)	BARDY诊断, INC.		
[标]发明人	FELIX JASON BISHAY JON MIKALSON BARDY GUST H		
发明人	FELIX, JASON BISHAY, JON MIKALSON BARDY, GUST H.		
IPC分类号	A61B5/0432 A61B5/145 A61B5/0205 A61B5/0408 A61B5/00		
CPC分类号	A61B5/04325 A61B5/087 A61B5/04085 A61B5/0006 A61B5/0022 A61B5/7455 A61B5/7405 A61B5/02055 A61B5/14542 A61B5/14532 A61B5/6823 A61B5/7475 A61B2560/0214 A61B5/021 A61B5/0816 A61B5/04087 A61B5/03 A61B5/0452 A61B5/1118 A61B5/14551 G06F19/00 G16H40/67		
优先权	61/882403 2013-09-25 US		
其他公开文献	US9820665		
外部链接	Espacenet USPTO		

摘要(译)

提供了一种可远程连接的延长磨损心电图和生理传感器监视记录器。密封壳体在底表面上形成腔，该腔被成形为容纳形成在一次性延长耐磨电极贴片的非导电插座上的电池盒的向上突出，并且包括从底表面突出并被布置的一组电触点。与设置在非导电插座上的电焊盘对齐。电子电路设置在密封壳体内，并包括外部供电的微控制器，其可操作以在微可编程控制下执行。心电图前端电路与微控制器电连接。无线收发器与微控制器电连接，并且外部供电的闪存与微控制器电连接并且可操作以存储心电图信号的样本。

