



US 20150216446A1

(19) **United States**
(12) **Patent Application Publication**
Bukhman et al.

(10) **Pub. No.: US 2015/0216446 A1**
(43) **Pub. Date: Aug. 6, 2015**

(54) **SYSTEMS AND METHODS FOR GUIDANCE AND PLACEMENT OF AN INTRAVASCULAR DEVICE**

A61B 5/0452 (2006.01)
A61B 5/00 (2006.01)

(71) Applicant: **C. R. Bard, Inc.**, Murray Hill, NJ (US)

(72) Inventors: **Vladislav Bukhman**, East Northport, NY (US); **Anthony K. Misener**, Bountiful, UT (US); **Valeriy Vassylyev**, Kiev (UA); **Robin S. Urry**, Sandy, UT (US); **Brian S. Tanner**, Layton, UT (US)

(52) **U.S. Cl.**
CPC *A61B 5/062* (2013.01); *A61B 5/0452* (2013.01); *A61B 5/6824* (2013.01); *A61B 5/6823* (2013.01); *A61B 5/6847* (2013.01); *A61B 5/7405* (2013.01); *A61B 5/743* (2013.01); *A61B 8/0841* (2013.01); *A61B 5/04012* (2013.01)

(21) Appl. No.: **14/615,932**

(22) Filed: **Feb. 6, 2015**

Related U.S. Application Data

(60) Provisional application No. 61/936,825, filed on Feb. 6, 2014.

Publication Classification

(51) **Int. Cl.**
A61B 5/06 (2006.01)
A61B 5/04 (2006.01)
A61B 8/08 (2006.01)

(57) **ABSTRACT**
A guidance and placement system and associated methods for assisting a clinician in the placement of a catheter or other medical device within the vasculature of a patient is disclosed. In one embodiment, a method for guiding a medical device to a desired location within a vasculature of a patient is also disclosed and comprises detecting an intravascular ECG signal of the patient and identifying a P-wave of a waveform of the intravascular ECG signal, wherein the P-wave varies according to proximity of the medical device to the desired location. The method further comprises determining whether the identified P-wave is elevated, determining a deflection value of the identified P-wave when the identified P-wave is elevated, and reporting information relating to a location of the medical device within the patient's vasculature at least partially according to the determined deflection value of the elevated P-wave.

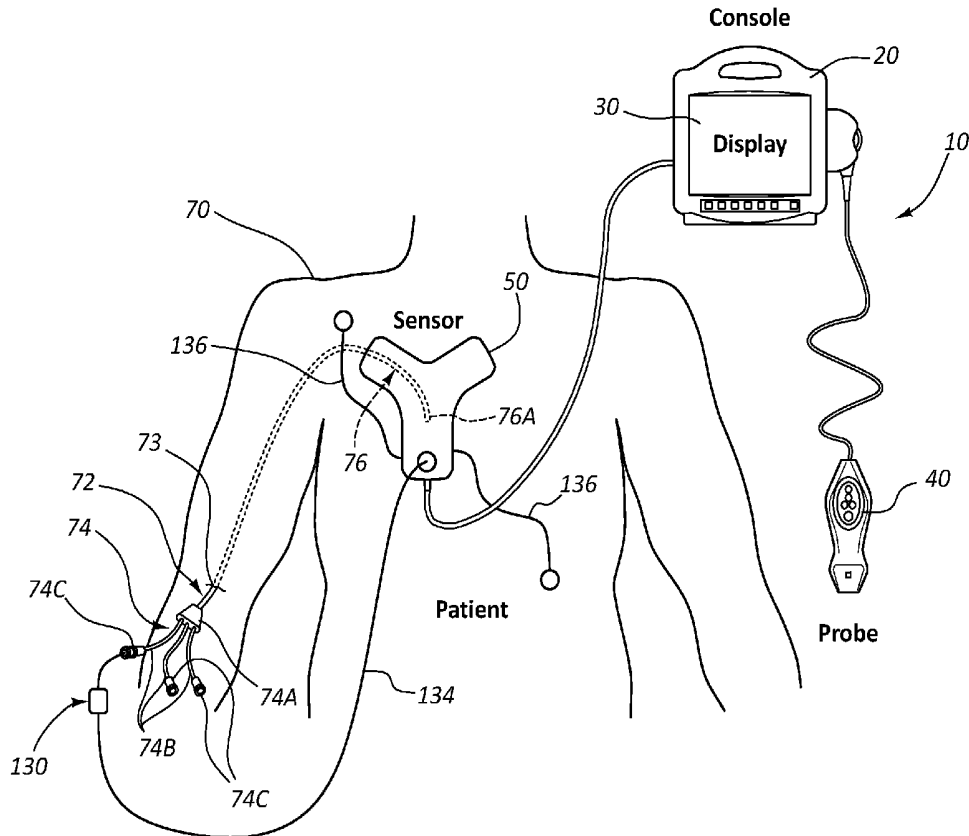

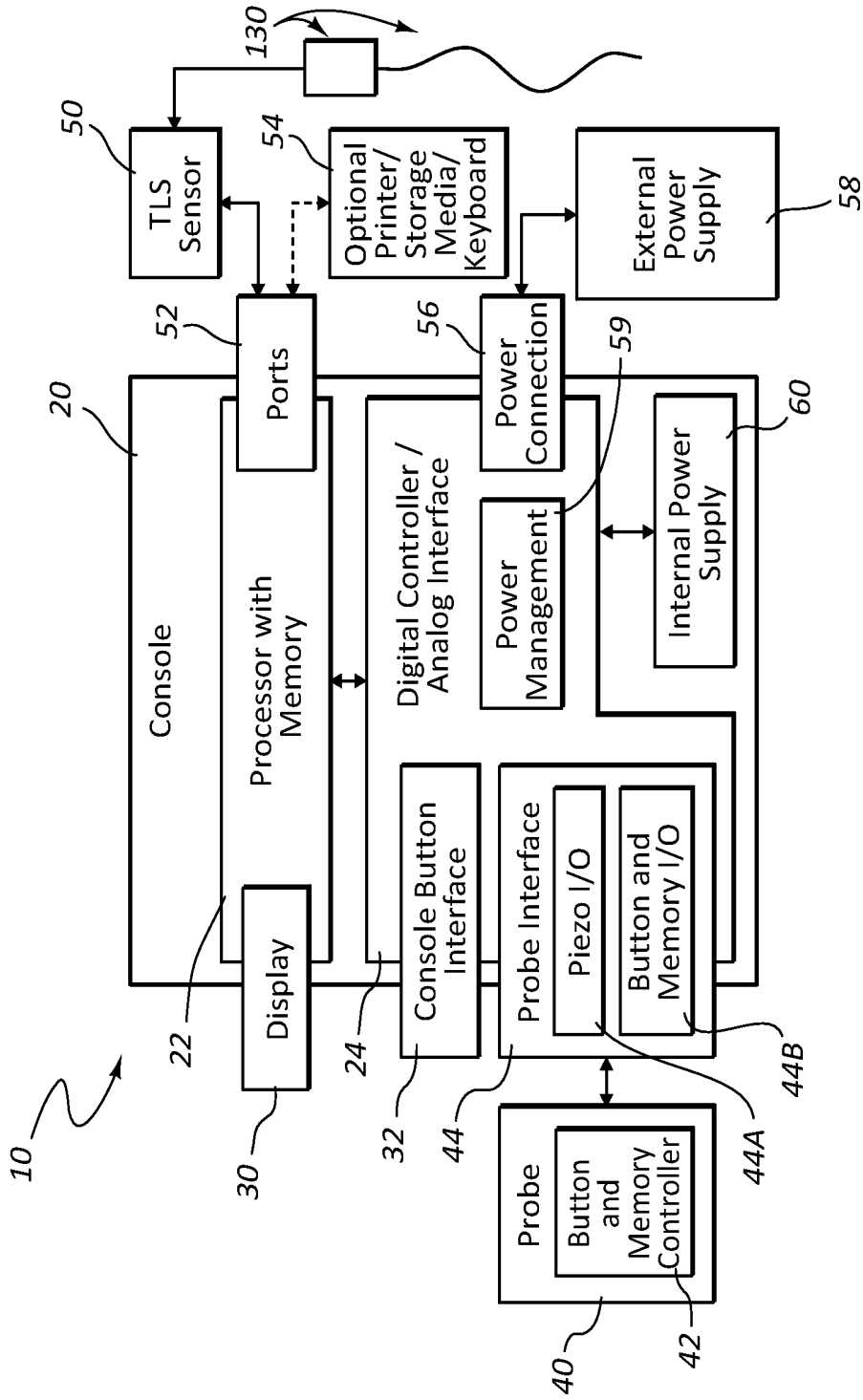

FIG. 1

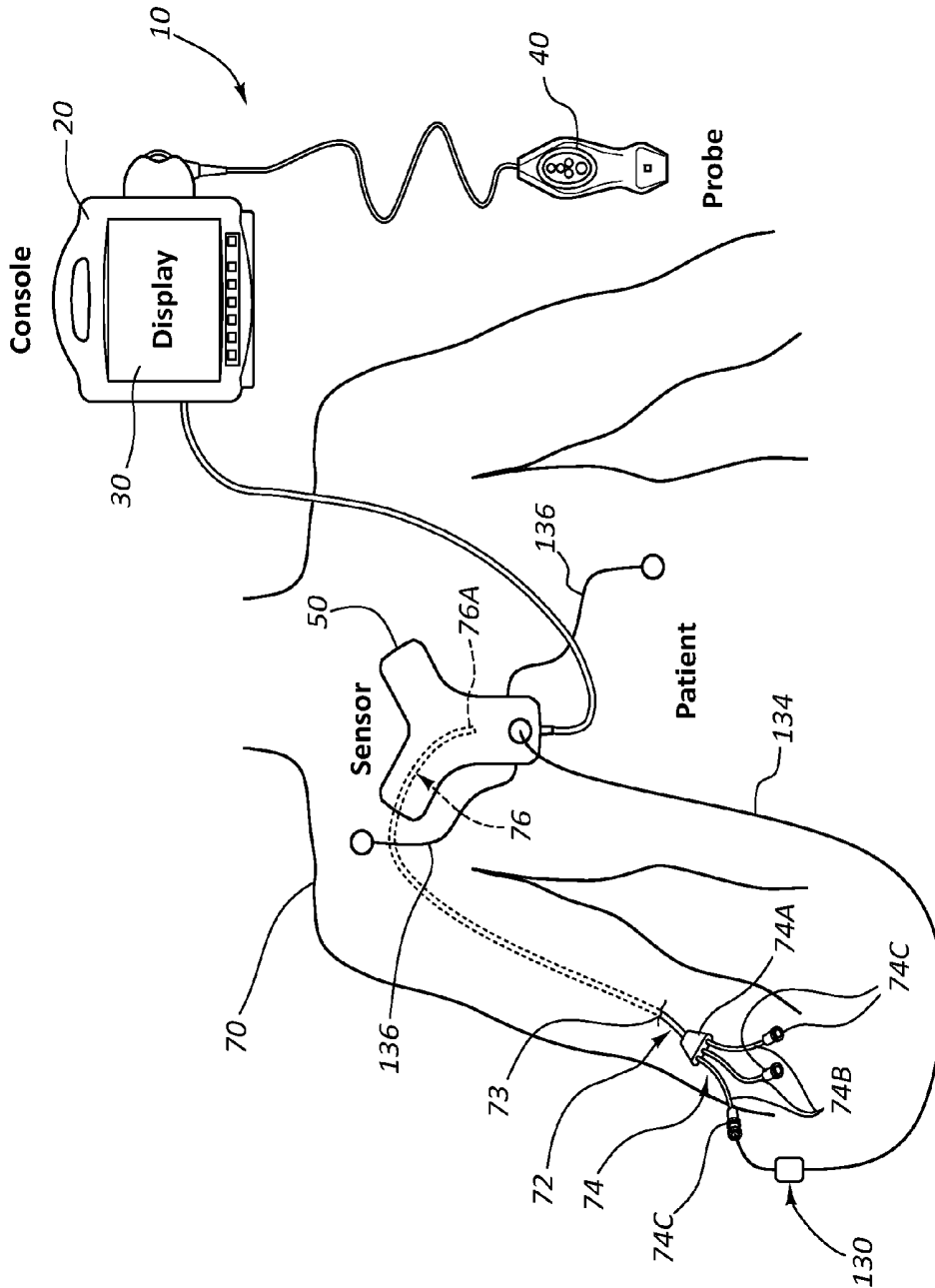

FIG. 2

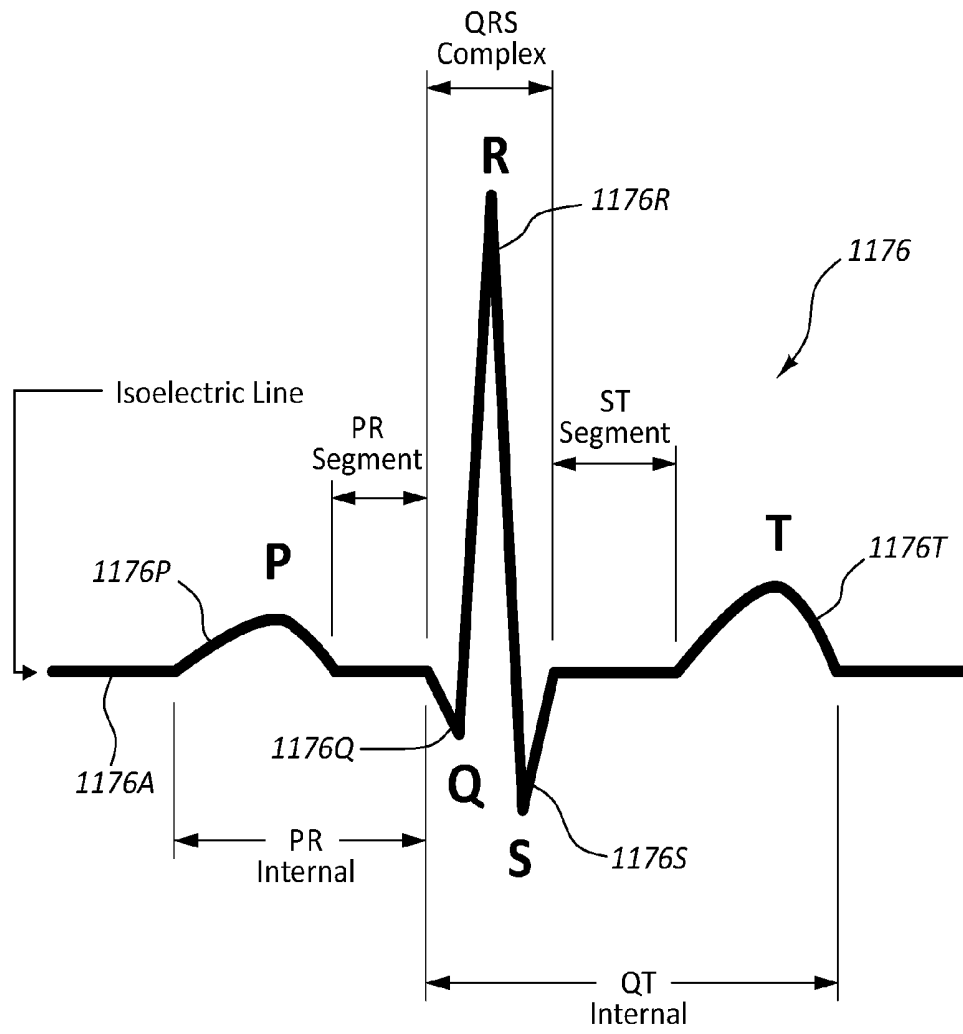

FIG. 3

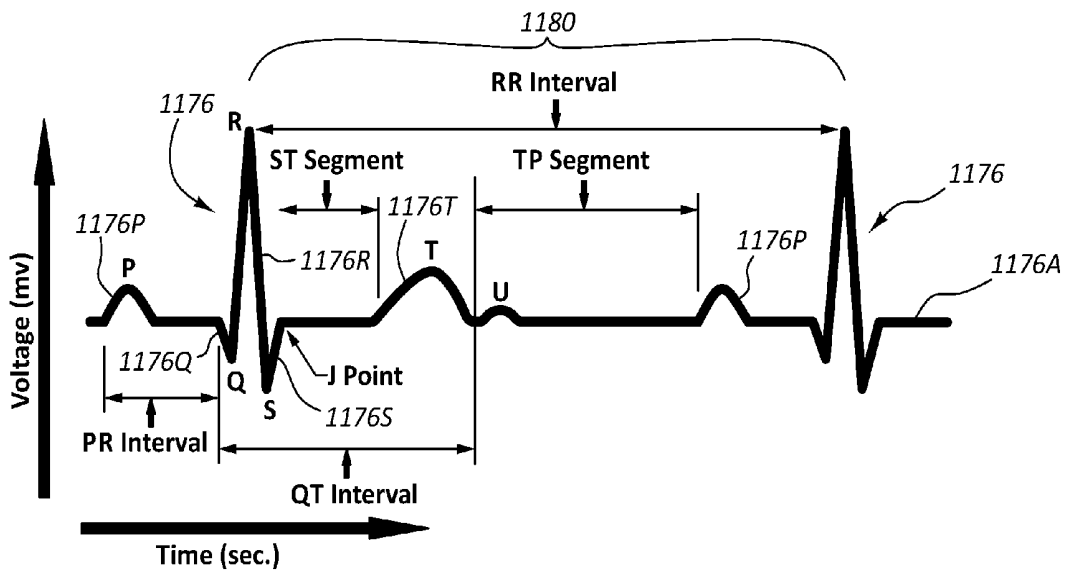

FIG. 4

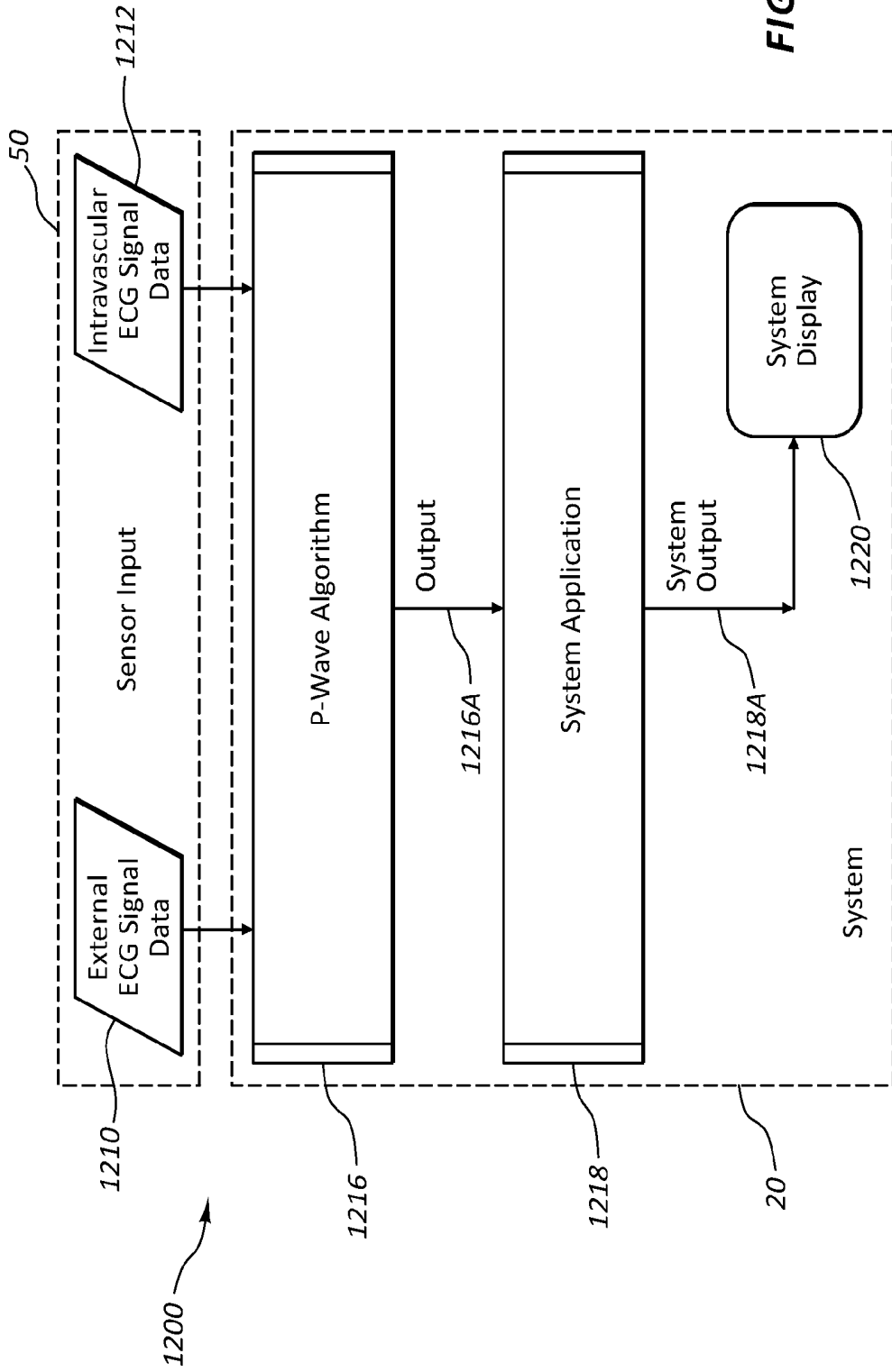

FIG. 5

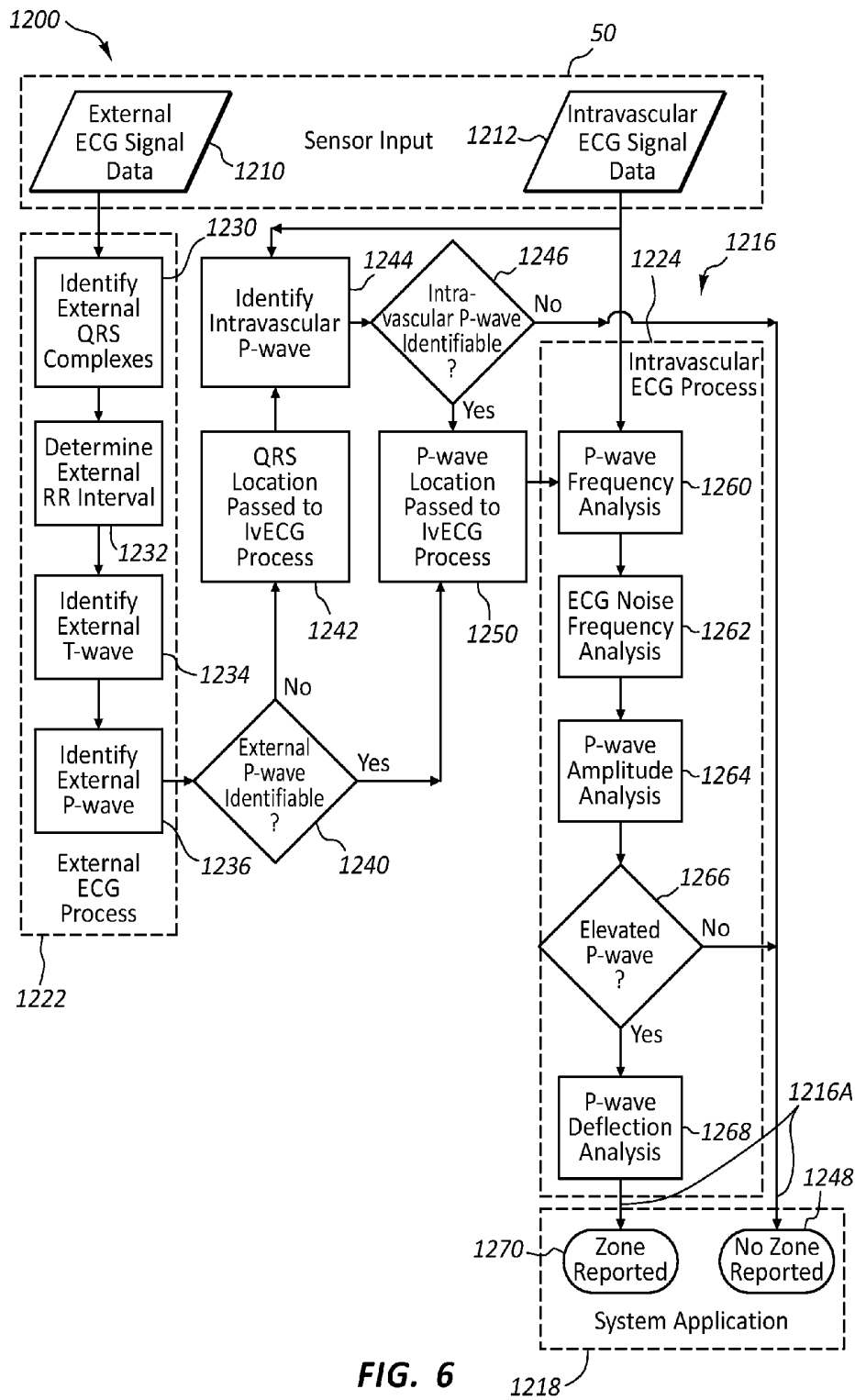

FIG. 6

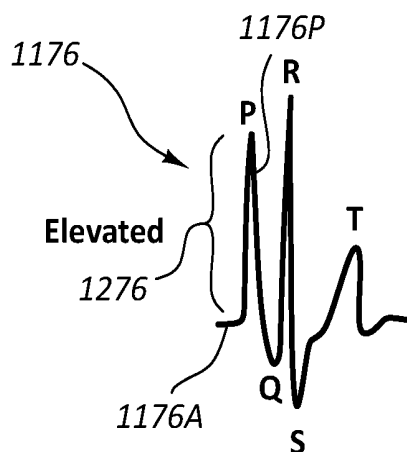

FIG. 7

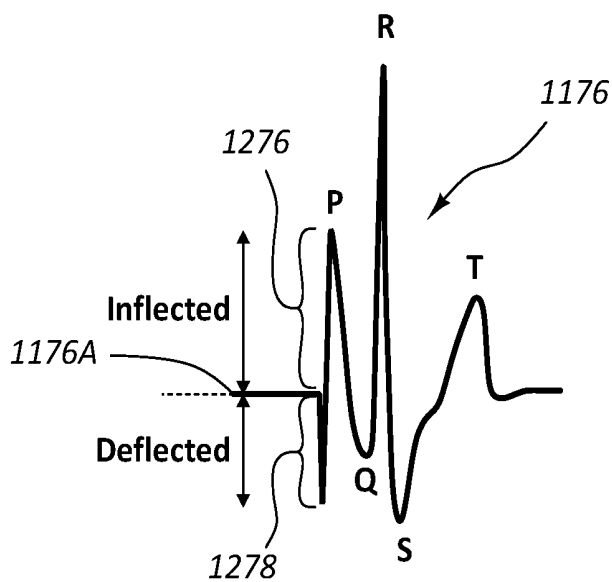

FIG. 8

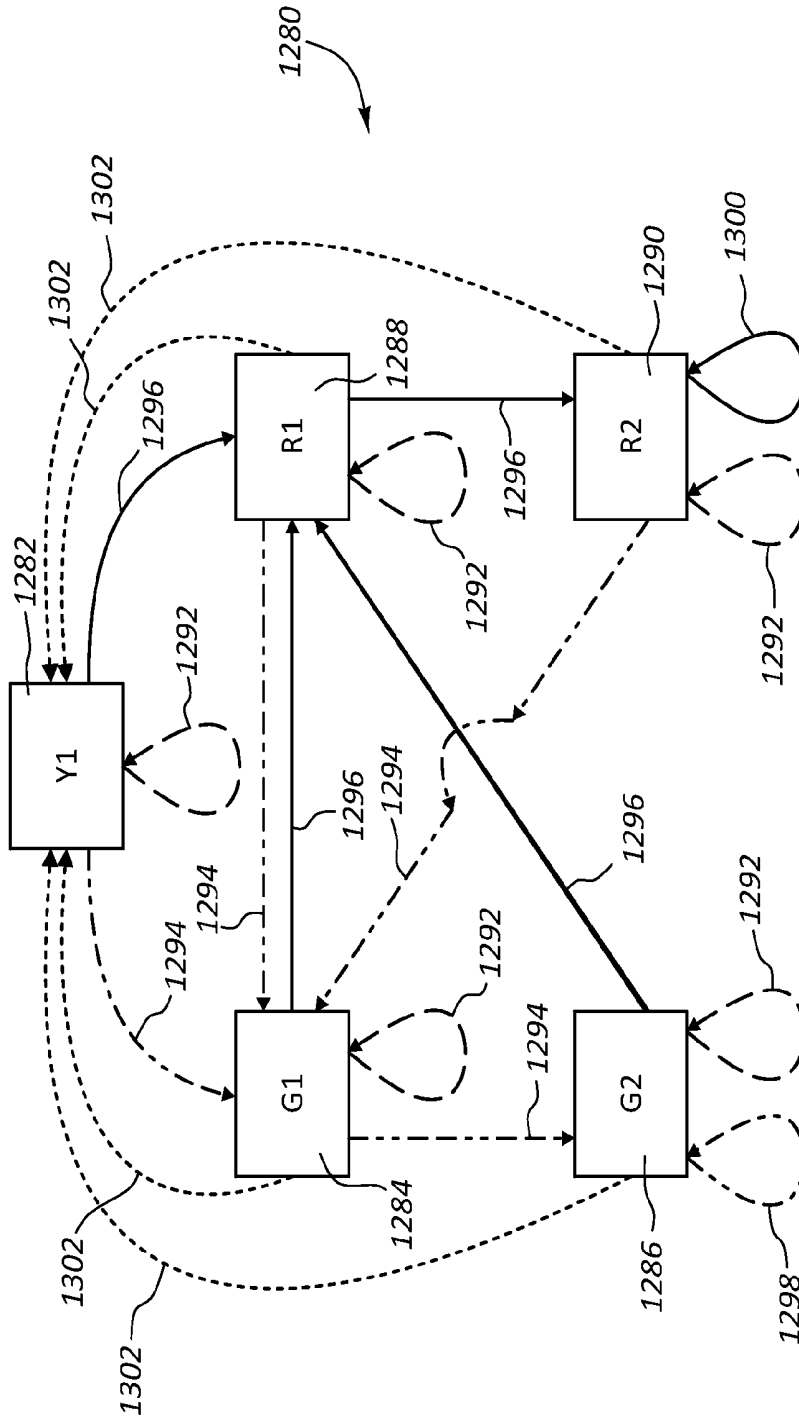

FIG. 9

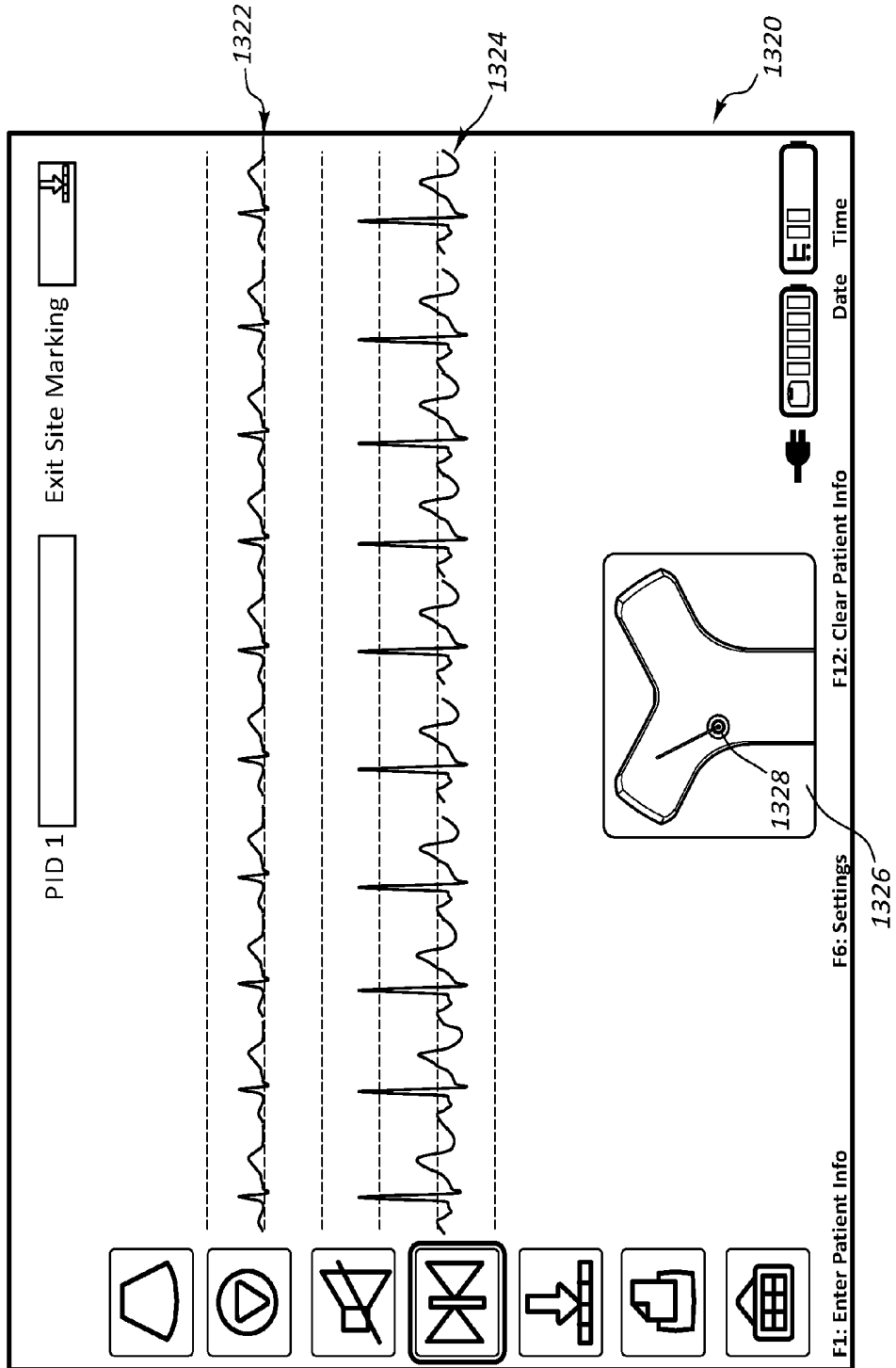

FIG. 10A

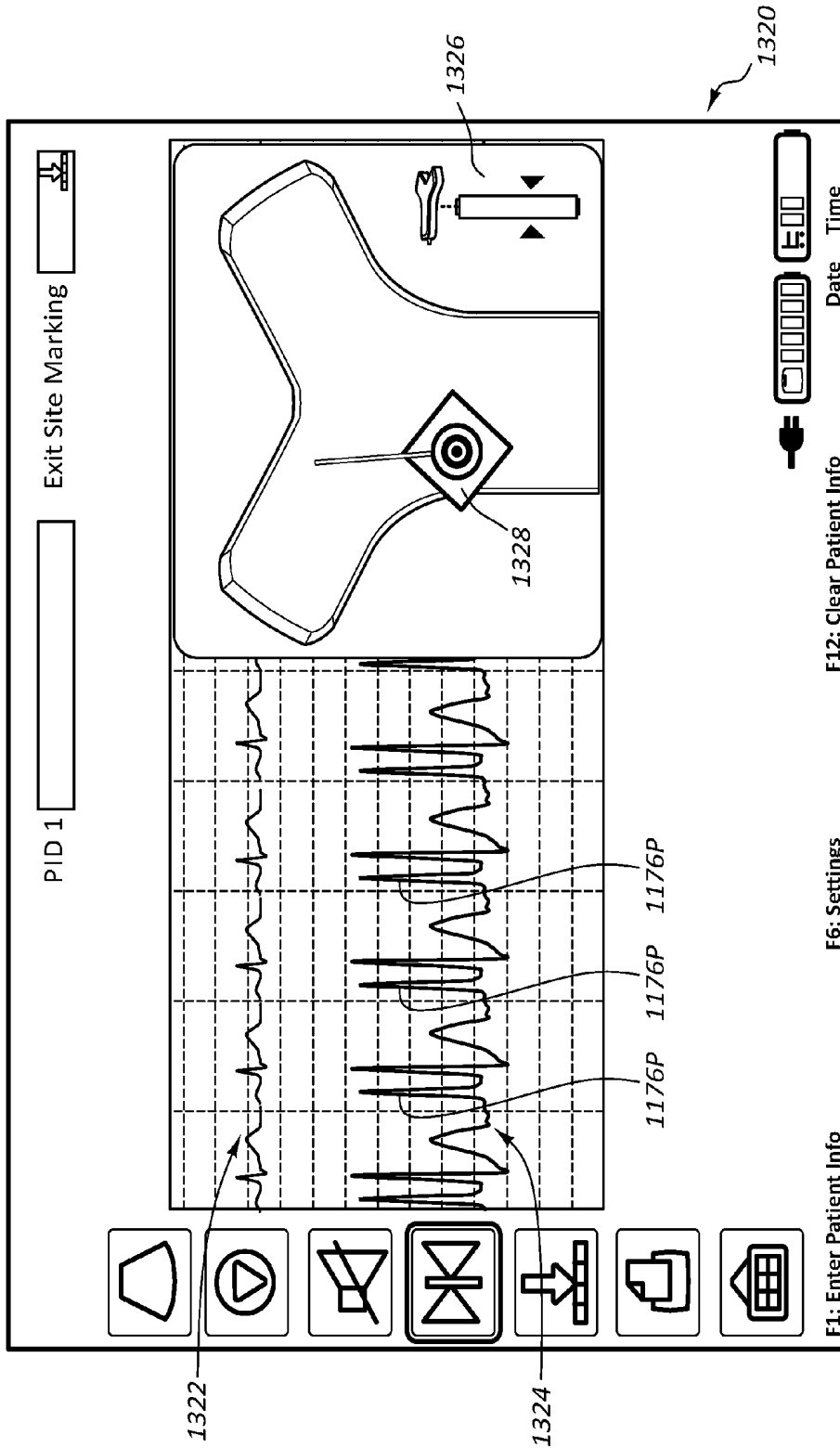

FIG. 10B

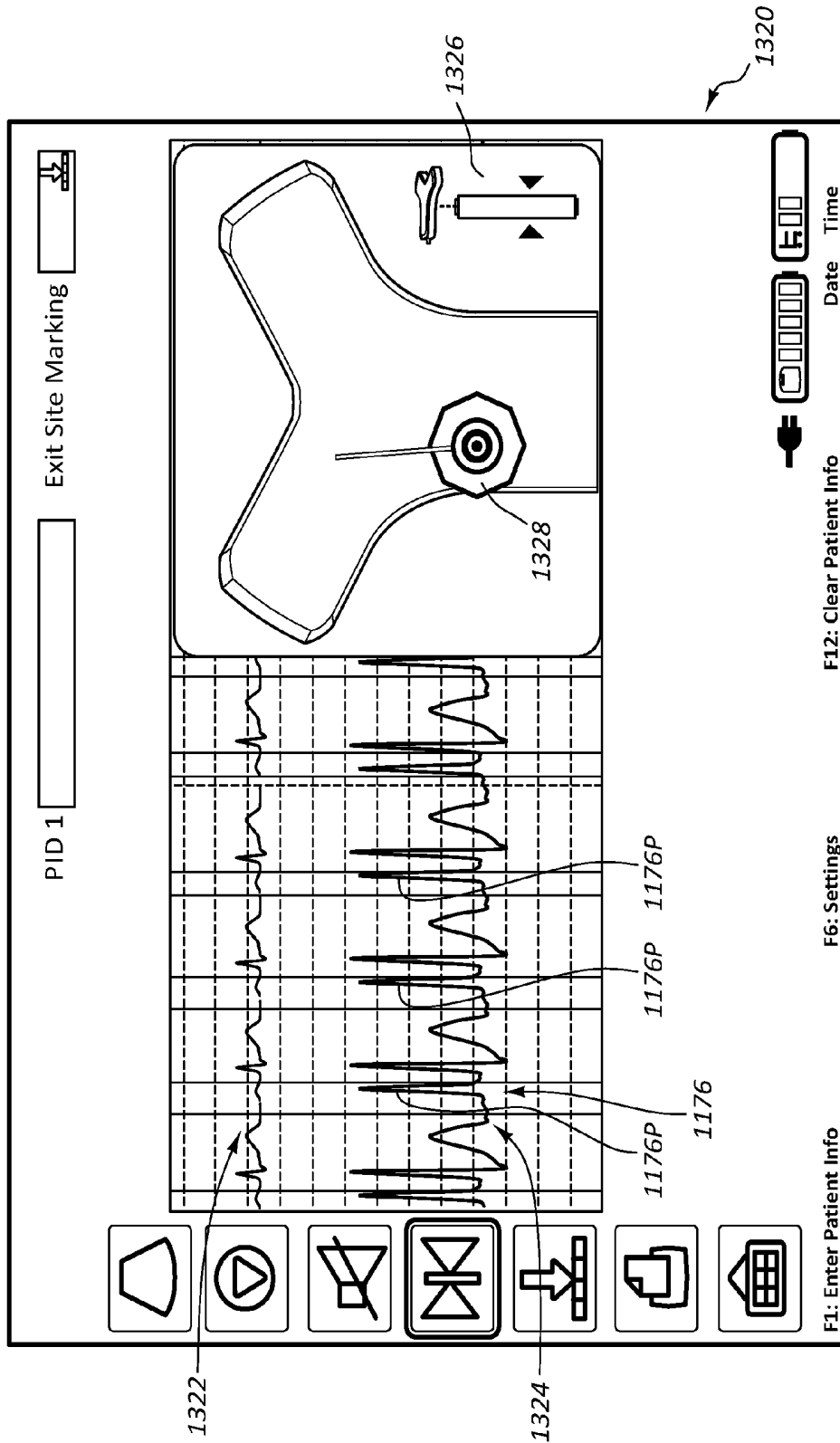

FIG. 10C

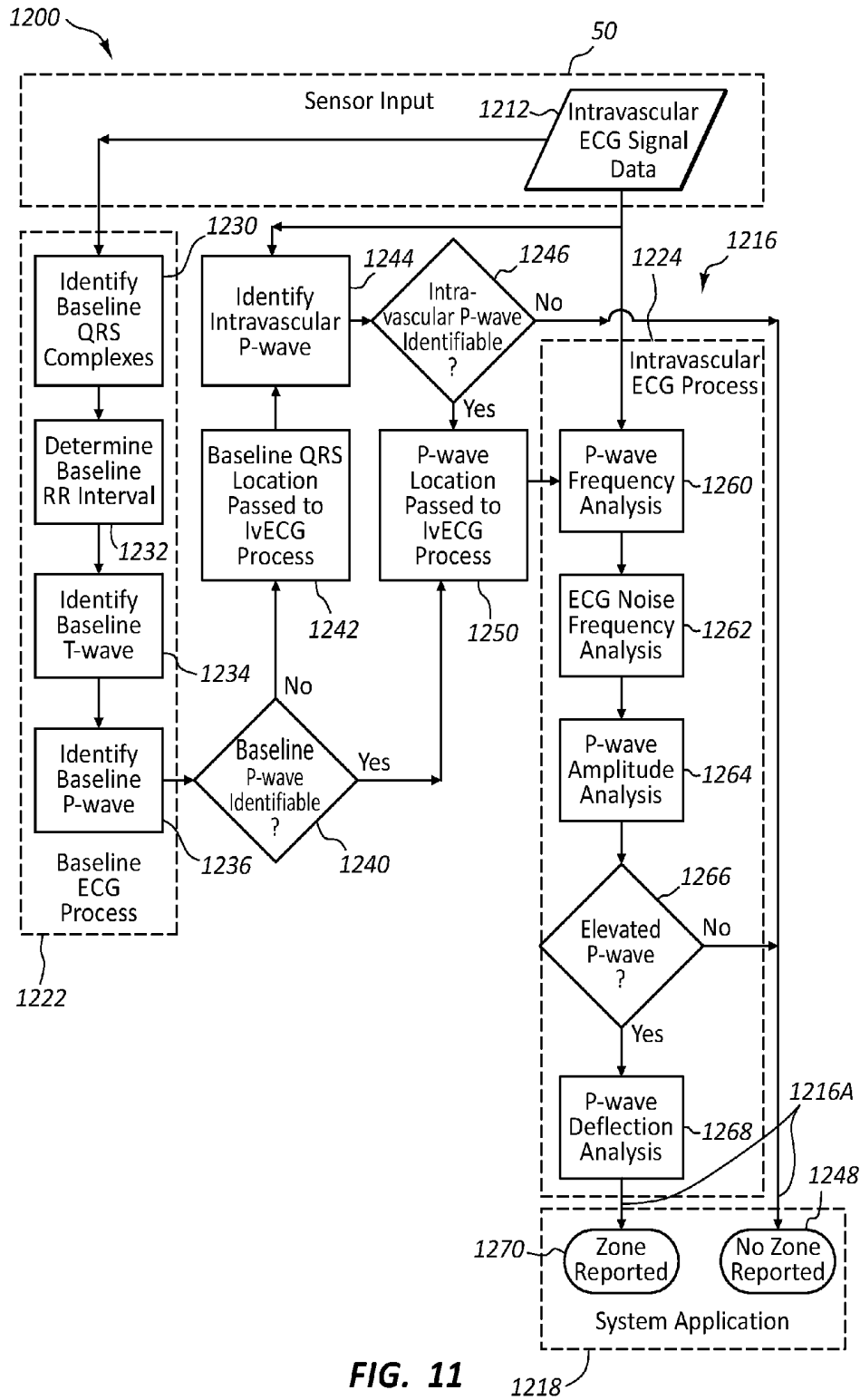

FIG. 11

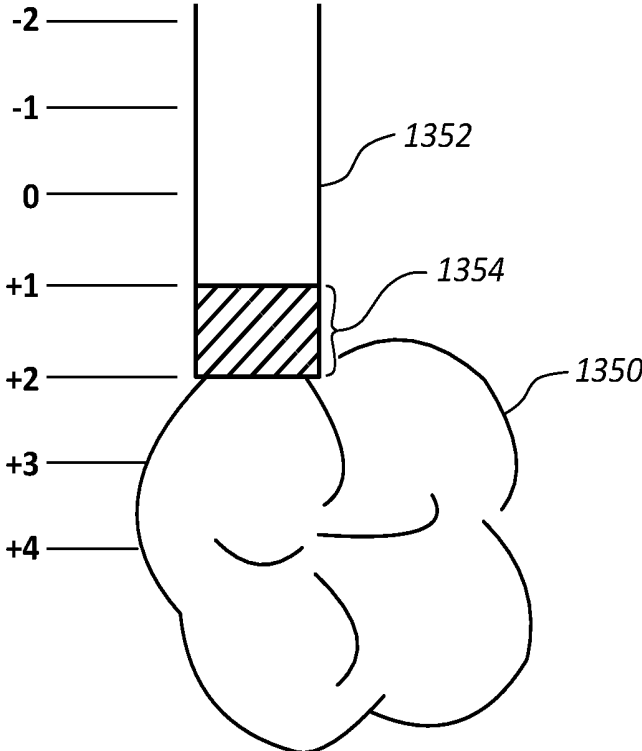

FIG. 12

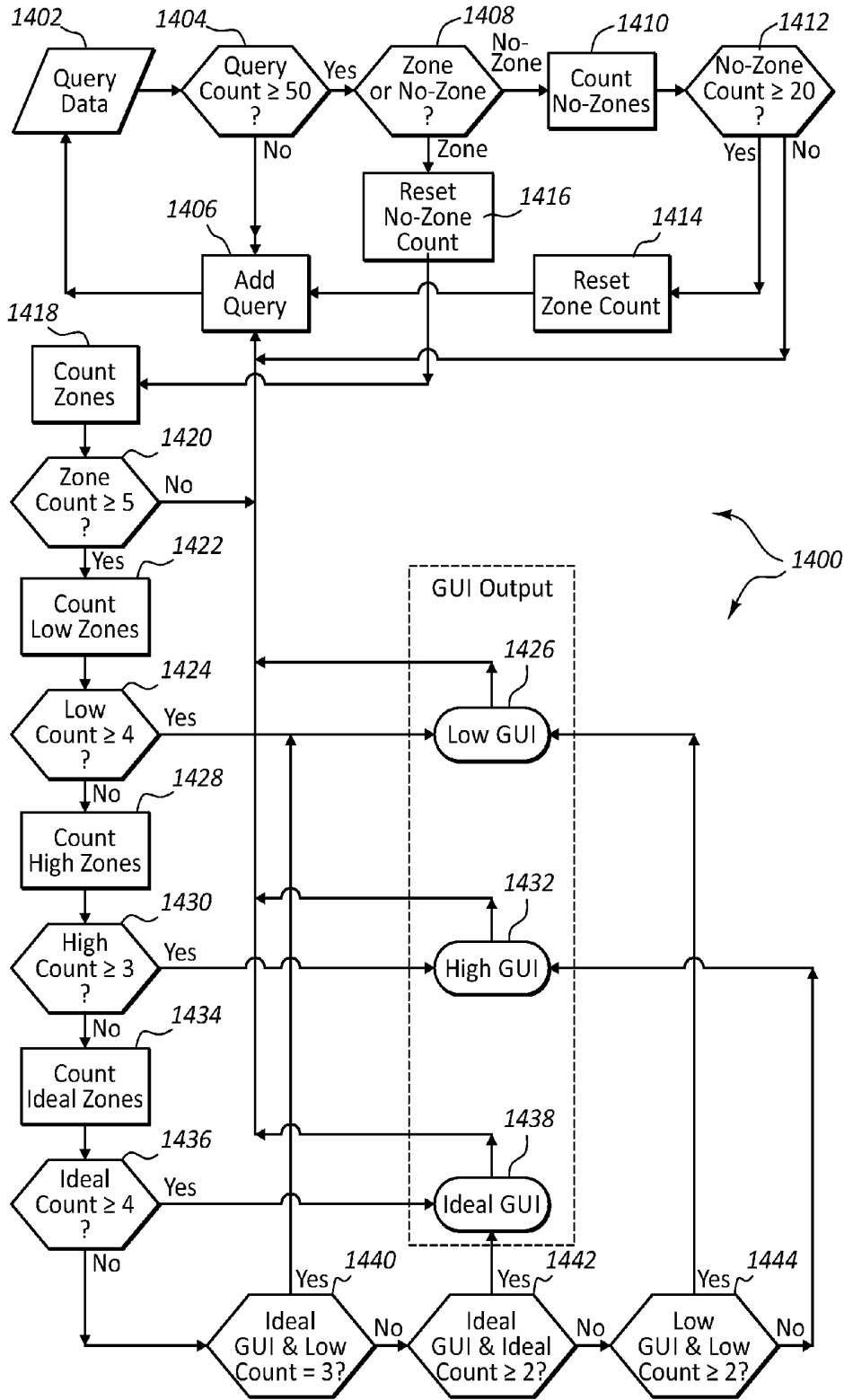

FIG. 13

SYSTEMS AND METHODS FOR GUIDANCE AND PLACEMENT OF AN INTRAVASCULAR DEVICE

CROSS-REFERENCE TO RELATED APPLICATIONS

[0001] This application claims the benefit of U.S. Provisional Patent Application No. 61/936,825, filed Feb. 6, 2014, and titled "SYSTEMS AND METHODS FOR GUIDANCE AND PLACEMENT OF AN INTRAVASCULAR DEVICE," which is incorporated herein by reference in its entirety.

BRIEF SUMMARY

[0002] Briefly summarized, embodiments of the present invention are directed to a guidance and placement system for assisting a clinician in the placement of a catheter or other medical device within the vasculature of a patient, and related methods. The guidance and placement system enables a distal tip of a catheter to be placed within the patient vasculature in desired proximity to the patient's heart using ECG signals produced by the heart.

[0003] In one embodiment, a method for guiding a medical device to a desired location within a vasculature of a patient is disclosed. The method comprises detecting an intravascular ECG signal of the patient and identifying a P-wave of a waveform of the intravascular ECG signal, wherein the P-wave varies according to proximity of the medical device to the desired location.

[0004] The method further comprises determining whether the identified P-wave is elevated, determining a deflection value of the identified P-wave when the identified P-wave is elevated, and reporting information relating to a location of the medical device within the patient's vasculature at least partially according to the determined deflection value of the elevated P-wave.

[0005] In one embodiment, the intended destination of the catheter within the patient body is such that the distal tip of the catheter is disposed in the lower $\frac{1}{3}^{rd}$ portion of the superior vena cava ("SVC"). The guidance and placement system analyzes the ECG signals of the patient to determine when the catheter has reached its intended destination within the vasculature, then notifies the clinician via a display, for instance. Thus, the system includes an ECG modality for assisting in medical device placement within the patient.

[0006] These and other features of embodiments of the present invention will become more fully apparent from the following description and appended claims, or may be learned by the practice of embodiments of the invention as set forth hereinafter.

BRIEF DESCRIPTION OF THE DRAWINGS

[0007] A more particular description of the present disclosure will be rendered by reference to specific embodiments thereof that are illustrated in the appended drawings. It is appreciated that these drawings depict only typical embodiments of the invention and are therefore not to be considered limiting of its scope. Example embodiments of the invention will be described and explained with additional specificity and detail through the use of the accompanying drawings in which:

[0008] FIG. 1 is a block diagram showing various components of a guidance and placement system according to one embodiment;

[0009] FIG. 2 shows the system of FIG. 1 in use to guide insertion and placement of a catheter into a body of a patient;

[0010] FIG. 3 shows various details of an ECG complex;

[0011] FIG. 4 shows various details of an ECG trace;

[0012] FIG. 5 is a block diagram showing various aspects of a guidance and placement system according to one embodiment;

[0013] FIG. 6 is a block diagram showing various stages of a method for guiding a medical device according to one embodiment;

[0014] FIG. 7 shows various details of a captured intravascular ECG complex according to one embodiment;

[0015] FIG. 8 shows various details of a captured intravascular ECG complex according to one embodiment;

[0016] FIG. 9 shows a decision tree for determining display output to a guidance and placement system according to one embodiment;

[0017] FIGS. 10A-10C show various screenshots of a display of a guidance and placement system according to one embodiment;

[0018] FIG. 11 is a block diagram showing various stages of a method for guiding a medical device according to one embodiment;

[0019] FIG. 12 is a simplified view of a heart with possible reporting zones superimposed thereon, according to one embodiment; and

[0020] FIG. 13 shows a decision tree for determining display output to a guidance and placement system according to one embodiment.

DETAILED DESCRIPTION OF SELECTED EMBODIMENTS

[0021] Reference will now be made to figures wherein like structures will be provided with like reference designations. It is understood that the drawings are diagrammatic and schematic representations of exemplary embodiments of the present invention, and are neither limiting nor necessarily drawn to scale.

[0022] For clarity it is to be understood that the word "proximal" refers to a direction relatively closer to a clinician using the device to be described herein, while the word "distal" refers to a direction relatively further from the clinician. For example, the end of a catheter placed within the body of a patient is considered a distal end of the catheter, while the catheter end remaining outside the body is a proximal end of the catheter. Also, the words "including," "has," and "having," as used herein, including the claims, shall have the same meaning as the word "comprising."

[0023] Embodiments of the present invention are generally directed to a guidance and placement system, also referred to herein as a "placement system" or "system," for assisting a clinician in the placement of a catheter or other medical device within the body of a patient, such as within the vasculature. In one embodiment, the guidance and placement system enables a distal tip of a catheter to be placed within the patient vasculature in desired proximity to the heart using ECG signals produced by the patient's heart. In one embodiment, the medical device includes a catheter and the intended destination of the catheter within the patient body is such that the distal tip of the catheter is disposed in the lower $\frac{1}{3}^{rd}$ portion of the superior vena cava ("SVC"). The guidance and

placement system analyzes the ECG signals of the patient to determine when the catheter has reached its intended destination within the vasculature, then notifies the clinician via a display, for instance. Thus, the system includes an ECG modality for assisting in medical device placement within the patient.

[0024] In one embodiment, the above-referenced ECG guidance modality of the guidance and placement system is accompanied by an ultrasound (“US”) modality to assist with initial insertion of the medical device into the body, and a magnetic element-based tracking, or tip location system (“TLS”) modality to track the position and orientation of the medical device as it advances toward its intended destination.

[0025] Reference is first made to FIGS. 1 and 2 which depict various components of a placement system (“system”), generally designated at 10, configured in accordance with one example embodiment of the present invention. As shown, the system 10 generally includes a console 20, display 30, probe 40, and sensor 50, each of which is described in further detail below.

[0026] FIG. 2 shows the general relation of these components to a patient 70 during a procedure to place a catheter 72 into the patient vasculature through a skin insertion site 73. FIG. 2 shows that the catheter 72 generally includes a proximal portion 74 that remains exterior to the patient and a distal portion 76 that resides within the patient vasculature after placement is complete. In the present embodiment, the system 10 is employed to ultimately position a distal tip 76A of the catheter 72 in a desired position within the patient vasculature. In one embodiment, the desired position for the catheter distal tip 76A is proximate the patient’s heart, such as in the lower one-third ($\frac{1}{3}^{rd}$) portion of the Superior Vena Cava (“SVC”). Of course, the system 10 can be employed to place the catheter distal tip in other locations. The catheter proximal portion 74 further includes a hub 74A that provides fluid communication between the one or more lumens of the catheter 72 and one or more extension legs 74B extending proximally from the hub.

[0027] A processor 22, including non-volatile memory such as EEPROM for instance, is included in the console 20 for controlling system function during operation of the system 10, thus acting as a control processor. A digital controller/analog interface 24 is also included with the console 20 and is in communication with both the processor 22 and other system components to govern interfacing between the probe 40, sensor 50, and other system components.

[0028] The system 10 further includes ports 52 for connection with the sensor 50 and optional components 54 including a printer, storage media, keyboard, etc. The ports in one embodiment are USB ports, though other port types or a combination of port types can be used for this and the other interfaces connections described herein. A power connection 56 is included with the console 20 to enable operable connection to an external power supply 58. An internal battery 60 can also be employed, either with or exclusive of an external power supply. Power management circuitry 59 is included with the digital controller/analog interface 24 of the console to regulate power use and distribution.

[0029] The display 30 in the present embodiment is integrated into the console 20 and is used to display information to the clinician during the catheter placement procedure. In another embodiment, the display may be separate from the console. As will be seen, the content depicted by the display 30 changes according to which mode the catheter placement

system is in: US, TLS, or in other embodiments, ECG tip confirmation. In one embodiment, a console button interface 32 and buttons included on the probe 40 can be used to immediately call up a desired mode to the display 30 by the clinician to assist in the placement procedure. In one embodiment, information from multiple modes, such as TLS and ECG, may be displayed simultaneously. Thus, the single display 30 of the system console 20 can be employed for ultrasound guidance in accessing a patient’s vasculature, TLS guidance during catheter advancement through the vasculature, and (as in later embodiments) ECG-based confirmation of catheter distal tip placement with respect to a node of the patient’s heart. In one embodiment, the display 30 is an LCD device.

[0030] The probe 40 is employed in connection with the first modality mentioned above, i.e., ultrasound (“US”)-based visualization of a vessel, such as a vein, in preparation for insertion of the catheter 72 into the vasculature. Such visualization gives real time ultrasound guidance for introducing the catheter into the vasculature of the patient and assists in reducing complications typically associated with such introduction, including inadvertent arterial puncture, hematoma, pneumothorax, etc.

[0031] As such, in one embodiment a clinician employs the first, US, modality to determine a suitable insertion site and establish vascular access, such as with a needle and introducer, then with the catheter. The clinician can then seamlessly switch, via button pushes on the probe button pad, to the second, TLS, modality without having to reach out of the sterile field. The TLS mode can then be used to assist in advancement of the catheter 72 through the vasculature toward an intended destination.

[0032] FIG. 1 shows that the probe 40 further includes button and memory controller 42 for governing button and probe operation. The button and memory controller 42 can include non-volatile memory, such as EEPROM, in one embodiment. The button and memory controller 42 is in operable communication with a probe interface 44 of the console 20, which includes a piezo input/output component 44A for interfacing with the probe piezoelectric array and a button and memory input/output component 44B for interfacing with the button and memory controller 42.

[0033] Note that while a vein is typically depicted on the display 30 during use of the system 10 in the US modality, other body lumens or portions can be imaged in other embodiments. Note that the US mode can be simultaneously depicted on the display 30 with other modes, such as the TLS mode or ECG mode, if desired. In addition to the visual display 30, aural information, such as beeps, tones, etc., or vibratory/motion-based cues can also be employed by the system 10 to assist the clinician during catheter placement. Moreover, the buttons included on the probe 40 and the console button interface 32 can be configured in a variety of ways, including the use of user input controls in addition to buttons, such as slide switches, toggle switches, electronic or touch-sensitive pads, etc. Additionally, US, TLS, and ECG activities can occur simultaneously or exclusively during use of the system 10.

[0034] As just described, the handheld ultrasound probe 40 is employed as part of the integrated catheter placement system 10 to enable US visualization of the peripheral vasculature of a patient in preparation for transcatheter introduction of the catheter. In the present example embodiment, however, the probe is also employed to control functionality

of the TLS portion, or second modality, of the system **10** when navigating the catheter toward its desired destination within the vasculature as described below. Again, as the probe **40** is used within the sterile field of the patient, this feature enables TLS functionality to be controlled entirely from within the sterile field. Thus the probe **40** is a dual-purpose device, enabling convenient control of both US and TLS functionality of the system **10** from the sterile field. In one embodiment, the probe can also be employed to control some or all ECG-related functionality, or third modality, of the catheter placement system **10**, as described further below.

[0035] The catheter placement system **10** further includes the second modality mentioned above, i.e., the magnetically-based catheter TLS, or tip location system. The TLS enables the clinician to quickly locate and confirm the position and/or orientation of the catheter **72**, such as a peripherally-inserted central catheter (“PICC”), central venous catheter (“CVC”), or other suitable catheter or medical device, during initial placement into and advancement through the vasculature of the patient **70**. Specifically, the TLS modality detects a magnetic field generated by a magnetic element-equipped tip location stylet, which is pre-loaded in one embodiment into a longitudinally defined lumen of the catheter **72**, thus enabling the clinician to ascertain the general location and orientation of the catheter tip within the patient body. In one embodiment, the magnetic assembly can be tracked using the teachings of one or more of the following U.S. Pat. Nos. 5,775,322; 5,879,297; 6,129,668; 6,216,028; and 6,263,230. The contents of the afore-mentioned U.S. patents are incorporated herein by reference in their entireties. The TLS also displays the direction in which the catheter tip is pointing, thus further assisting accurate catheter placement. The TLS further assists the clinician in determining when a malposition of the catheter tip has occurred, such as in the case where the tip has deviated from a desired venous path into another vein.

[0036] As mentioned, the TLS utilizes a stylet to enable the distal end of the catheter **72** to be tracked during its advancement through the vasculature. In one embodiment, the stylet includes a proximal end and a distal end, with a handle included at the proximal end and a core wire extending distally therefrom. A magnetic assembly is disposed distally of the core wire. The magnetic assembly includes one or more magnetic elements disposed adjacent one another proximate the stylet distal end and encapsulated by tubing. In the present embodiment, a plurality of magnetic elements is included, each element including a solid, cylindrically shaped ferromagnetic stacked end-to-end with the other magnetic elements. An adhesive tip can fill the distal tip of the tubing, distally to the magnetic elements.

[0037] Note that in other embodiments, the magnetic elements may vary from the design in not only shape, but also composition, number, size, magnetic type, and position in the stylet distal segment. For example, in one embodiment, the plurality of ferromagnetic magnetic elements is replaced with an electromagnetic assembly, such as an electromagnetic coil, which produces a magnetic field for detection by the sensor. Another example of an assembly usable here can be found in U.S. Pat. No. 5,099,845, entitled “Medical Instrument Location Means,” which is incorporated herein by reference in its entirety. Yet other examples of stylets including magnetic elements that can be employed with the TLS modality can be found in U.S. Pat. No. 8,784,336, entitled “Stylet Apparatuses and Methods of Manufacture,” which is incorporated herein by reference in its entirety. These and other

variations are therefore contemplated by embodiments of the present invention. It should be appreciated herein that “stylet” as used herein can include any one of a variety of devices configured for removable placement within a lumen of the catheter to assist in placing a distal end of the catheter in a desired location within the patient’s vasculature. In one embodiment, the stylet includes a guidewire.

[0038] FIG. 2 shows disposal of a stylet **130** substantially within a lumen in the catheter **72** such that the proximal portion thereof extends proximally from the catheter lumen, through the hub **74A** and out through a selected one of the extension legs **74B**. So disposed within a lumen of the catheter, the distal end **100B** of the stylet **100** in the present embodiment is substantially co-terminal with the distal catheter end **76A** such that detection by the TLS of the stylet distal end correspondingly indicates the location of the catheter distal end. In other embodiments, other positional relationships between the distal ends of the stylet and catheter or medical device are possible.

[0039] The TLS sensor **50** is employed by the system **10** during TLS operation to detect the magnetic field produced by the magnetic elements of the stylet **130**. As seen in FIG. 2, the TLS sensor **50** is placed on the chest of the patient during catheter insertion. The TLS sensor **50** is positioned on the chest of the patient in a predetermined location, such as through the use of external body landmarks, to enable the magnetic field of the stylet magnetic elements, disposed in the catheter **72** as described above, to be detected during catheter transit through the patient vasculature. Again, as the magnetic elements of the stylet magnetic assembly are co-terminal with the distal end **76A** of the catheter **72** in one embodiment (FIG. 2), detection by the TLS sensor **50** of the magnetic field of the magnetic elements provides information to the clinician as to the position and orientation of the catheter distal end during its transit.

[0040] In greater detail, the TLS sensor **50** is operably connected to the console **20** of the system **10** via one or more of the ports **52**, as shown in FIG. 1. Note that other connection schemes between the TLS sensor and the system console can also be used without limitation. As just described, the magnetic elements are employed in the stylet **130** to enable the position of the catheter distal end **76A** (FIG. 2) to be observable relative to the TLS sensor **50** placed on the patient’s chest. Detection by the TLS sensor **50** of the stylet magnetic elements is graphically displayed on the display **30** of the console **20** during TLS mode. In this way, a clinician placing the catheter is able to generally determine the location of the catheter distal end **76A** within the patient vasculature relative to the TLS sensor **50** and detect when catheter malposition, such as advancement of the catheter along an undesired vein, is occurring.

[0041] As discussed above, the system **10** includes additional functionality in the present embodiment wherein determination of the proximity of the catheter distal tip **76A** relative to a sino-atrial (“SA”) or other electrical impulse-emitting node of the heart of the patient **70** can be determined, thus providing enhanced ability to accurately place the catheter distal tip in a desired location proximate the node. Also referred to herein as “ECG” or “ECG-based tip confirmation,” this third modality of the system **10** enables detection of ECG signals from the SA node in order to place the catheter distal tip in a desired location within the patient vasculature. Note that the US, TLS, and ECG modalities are seamlessly combined in the present system **10**, but can be employed in

concert or individually to assist in catheter placement. In one embodiment, it is understood that the ECG modality as described herein can be included in a stand-alone system without the inclusion of the US and TLS modalities. Thus, the environments in which the embodiments herein are described are understood as merely example environments and are not considered limiting of the present disclosure.

[0042] As described, the catheter stylet **130** is removably predisposed within the lumen of the catheter **72** being inserted into the patient **70** via the insertion site **73**. The stylet **130**, in addition to including a magnetic assembly for the magnetically-based TLS modality, includes a sensing component, i.e., an internal, intravascular ECG sensor assembly, proximate its distal end and including a portion that is co-terminal with the distal end of the catheter tip for intravascularly sensing ECG signals produced by the SA node, in the present embodiment when the catheter **72** and accompanying stylet **130** are disposed within the patient vasculature. The intravascular ECG sensor assembly is also referred to herein as an internal or intravascular ECG sensor component.

[0043] The stylet **130** includes a tether **134** extending from its proximal end that operably connects to the TLS sensor **50**, though other connection schemes to the system **10** are contemplated. As will be described in further detail, the stylet tether **134** permits ECG signals detected by the ECG sensor assembly included on a distal portion of the stylet **130** to be conveyed to the TLS sensor **50** during confirmation of the catheter tip location as part of the ECG signal-based tip confirmation modality.

[0044] External reference and ground ECG electrodes **136** attach to the body of the patient **70** in the present embodiment and are operably attached to the TLS sensor **50** to provide an external baseline ECG signal to the system **10** and to enable the system to filter out high level electrical activity unrelated to the electrical activity of the SA node of the heart, thus enabling the ECG-based tip confirmation functionality. As shown, in the present embodiment, one external electrode **136** is placed on the patient skin proximate the upper right shoulder (“right arm” placement) while another external electrode is placed proximate the lower left abdomen (“left leg” placement). This electrode arrangement provides a lead II configuration according to Einthoven’s triangle of electrocardiography. Operable attachment of the external electrodes **136** with the sensor **50** enables the ECG signals detected by the external electrodes to be conveyed to the console **20** of the system **10** or to another suitable destination. As such, the external electrodes **136** serve as one example of an external ECG sensor component. Other external sensors for detecting a baseline ECG signal external to the patient body can also be employed in other embodiments. In addition, other electrode locations are also possible.

[0045] Together with the external ECG signal received from the external ECG sensor component (i.e., the external ECG electrodes **136** placed on the patient’s skin), an internal, intravascular ECG signal sensed by the internal ECG sensor component (i.e., the stylet ECG sensor assembly of the stylet **130**), is received by the TLS sensor **50** positioned on the patient’s chest (FIG. **10**) or other designated component of the system **10**. The TLS sensor **50** and/or console processor **22** can process the external and internal ECG signal data to produce one or more electrocardiogram traces, including a series of discrete ECG complexes, on the display **30**, as will be described. In the case where the TLS sensor **50** processes the external and internal ECG signal data, a processor is

included therein to perform the intended functionality. If the console **20** processes the ECG signal data, the processor **22**, controller **24**, or other processor can be utilized in the console to process the data.

[0046] Thus, as it is advanced through the patient vasculature, the catheter **72** equipped with the stylet **130** as described above can advance under the TLS sensor **50**, which is positioned on the chest of the patient as shown in FIG. **10**. This enables the TLS sensor **50** to detect the position of the magnetic assembly of the stylet **130** (described further above), which is substantially co-terminal with the distal tip **76A** of the catheter as located within the patient’s vasculature. The detection by the TLS sensor **50** of the stylet magnetic assembly is depicted on the display **30** during ECG mode.

[0047] The display **30** can further depict during ECG mode one or more ECG electrocardiogram traces produced as a result of patient heart’s electrical activity as detected by the external and internal ECG sensor components described above. In greater detail, the ECG electrical activity of the SA node, including the P-wave of the trace, is detected by the external and internal sensor components and forwarded to the TLS sensor **50** and console **20**. The ECG electrical activity is then processed for depiction on the display **30**, as will be described further below.

[0048] A clinician placing the catheter can then observe the ECG data, which assists in determining optimum placement of the distal tip **76A** of the catheter **72**, such as proximate the SA node, for instance. In one embodiment, the console **20** includes the electronic components, such as the processor **22** (FIG. **1**), necessary to receive and process the signals detected by the external and internal sensor components. In another embodiment, the TLS sensor **50** can include the necessary electronic components processing the ECG signals.

[0049] As already discussed, the display **30** is used to display information to the clinician during the catheter placement procedure. The content of the display **30** changes according to which mode the catheter placement system is in: US, TLS, or ECG. Any of the three modes can be immediately called up to the display **30** by the clinician, and in some cases information from multiple modes, such as TLS and ECG, may be displayed simultaneously. In one embodiment, as before, the mode the system is in may be controlled by the control buttons included on the handheld probe **40**, thus eliminating the need for the clinician to reach out of the sterile field (such as touching the button interface **32** of the console **20**) to change modes. Thus, in the present embodiment the probe **40** is employed to also control some or all ECG-related functionality of the system **10**. Note that the button interface **32** or other input configurations can also be used to control system functionality. Also, in addition to the visual display **30**, aural information, such as beeps, tones, etc., can also be employed by the system to assist the clinician during catheter placement.

[0050] Note that further details regarding the system **10** can be found in U.S. Pat. No. 8,848,382, issued Sep. 30, 2014, and entitled “Apparatus and Display Methods Relating to Intravascular Placement of a Catheter,” which is incorporated herein by reference in its entirety.

[0051] FIG. **3** depicts various details of an ECG complex **1176** of an electrocardiogram trace of a patient, including an isoelectric line **1176A**, a P-wave **1176P**, a Q-wave **1176Q**, an R-wave **1176R**, and S-wave **1176S**, and a T-wave **1176T**. FIG. **4** depicts further details and relationships between adjacent ECG complexes **1176**, including an RR interval **1180**

between successive ECG complexes, which is typically employed to determine the heart rate of the patient. These waves and intervals are used by the system 10 in the present embodiment to determine proximity of the catheter 72 or other medical device to the SA node or other desired location within the patient vasculature, as described herein.

[0052] FIG. 5 depicts an overview of the system 10 and a method 1200 for guiding the catheter to a desired intravascular location. As shown, the method 1200 employs external ECG data 1210 acquired from the external electrodes 136 (also referred to herein as external ECG sensor components) placed externally on the skin of the patient 70, as shown in FIG. 2, though the particular location of the electrodes can vary. As mentioned, the external electrodes 136 in the present embodiment are placed in a right arm/left leg “Lead II” arrangement.

[0053] The method 1200 further employs internal, intravascular ECG data 1212 acquired from the above-described internal ECG sensor component, implemented in the present embodiment as the ECG sensor assembly of the stylet 130. The external and intravascular ECG data 1210, 1212 is received and conditioned by processing componentry located in the TLS sensor 50 (FIG. 2) in one embodiment, though other system components can also include this functionality, such as the processor 22 of the system console 20.

[0054] Briefly and in accordance with one embodiment, the external and intravascular ECG data 1210, 1212 are input into a P-wave algorithm 1216 in order to determine intravascular proximity of the stylet distal tip to the SA node or other desired location within the patient 70 (FIG. 2). The P-wave algorithm 1216 in one embodiment is executed by a processor included in the TLS sensor 50, or in another embodiment by the processor 22 of the console 20, or by another suitable processor.

[0055] Output produced by the P-wave algorithm 1216 includes data relating to analysis of the P-wave of one or more ECG complexes of the intravascular ECG signal and corresponding zone designations relating to the proximity of the distal tip of the stylet 130 of the catheter 72 to the SA node of the heart. The output is received (via arrow 1216A) to a system application executed by the processor 22 of the system console 20, which can then output (via arrow 1218A) graphical information relating to the stylet distal tip position for depiction on a system display 1220, such as the display 30 of the system 10 (FIGS. 1, 2). Observation of the display 30 by the clinician of the information relating to the intravascular position of the stylet distal tip, which in the present embodiment is co-terminal with the distal tip of the catheter 72, aids the clinician in placing the catheter distal tip in the desired location.

[0056] FIG. 6 further depicts various details regarding the method 1200 (FIG. 5) for guiding the catheter according to the present embodiment. As shown, the method 1200 includes an external ECG process 1222 utilizing the external ECG data 1210 and an intravascular ECG process 1224 utilizing the intravascular ECG data 1212, with various intermediate actions. Again, in one embodiment the method 1200 is executed by a suitable processor, such as the processor 22 disposed in the system console 22 or a processor disposed in the TLS sensor 50, utilizing external and intravascular ECG signal data detected by the system components, as described above.

[0057] The top portion of FIG. 6 shows that the external ECG signal data 1210, including ECG complexes of an exter-

nal ECG signal detected by the external sensor component (i.e., the skin-placed external electrodes 136), is received by the TLS sensor 50. Likewise, the intravascular ECG signal data 1212, including ECG complexes of an intravascular ECG signal detected by the intravascular sensor component (i.e., the stylet ECG sensor assembly of the stylet 70), is also received by the TLS sensor 50. These data are utilized in the method 1200 as described below.

[0058] The external ECG process 1222, which utilizes the external ECG data 1210, is performed first in the present embodiment. Note that the process 1222, as with the other processes to be described herein, can be performed by a suitable processor included in the system 10 or operably associated therewith. As already mentioned, such a processor can include a processor of the TLS sensor 50, the processor 22 of the system console 10, etc.

[0059] The external ECG process 1222 includes stage 1230 wherein a QRS complex of a current ECG complex, such as the ECG complex 1176 (FIG. 3), is identified in the ECG signal of the external ECG signal data 1210. In particular, stage 1230 includes determining the location or point in time of occurrence of the QRS complex in the external ECG signal data 1210, which is also referred to herein as time-stamping of the QRS complex within the external ECG signal data 1210. Similar time-stamping can occur for other identified aspects of the ECG complex(es) of succeeding stages. In one embodiment, a 16th-order finite impulse response (“FIR”) filter is employed to identify two successive QRS complexes (waveforms) in stage 1230. Other modes can also be employed to identify this and other waveform components

[0060] Note that the external ECG signal data 1210 and the intravascular ECG signal data 1212 are time-synchronous such that the occurrence of the QRS complex or other aspect of an ECG complex detected in the external ECG signal data 1210 will correspond in time with the same aspect of the ECG complex detected in the intravascular ECG signal data 1212, in the present embodiment. Thus, the identified aspects of ECG complexes in the external ECG signal data 1210 can be used to find the corresponding aspects in the ECG complexes in the intravascular ECG signal data 1212.

[0061] At stage 1232, the time interval for the R-R interval, such as the R-R interval 1180 shown in FIG. 4, between two successive ECG complexes in the external ECG signal data 1210 is determined. This can be used, among other things, for determining patient heart rate.

[0062] At stage 1234, the T-wave, such as the T-wave 1176T of FIG. 3, is identified from the current ECG complex of the external ECG signal data 1210 under analysis. Finally, at stage 1236, the P-wave, such as the P-wave 1176P of FIG. 3, is identified from the current ECG complexes of the external ECG data 1210. With such identification, the time of onset (beginning), offset (ending), and maximum amplitude of the identified P-wave are performed at stage 1236 in the present embodiment.

[0063] Note that an algorithm to perform one embodiment of stages 1230 to 1236 has been developed as a object library or software library from Monebo Technologies, Inc., 1800 Barton Creek Blvd., Austin, Tex. 78735. In one embodiment, the software library can be accessed via an application program interface (“API”) as a callable function. The software library can be accessed by the system application 1218 (FIG. 5). Note also that, in one embodiment, multiple ECG com-

plexes of the external ECG signal data **1210** can be analyzed in performing the above-described stages of the external ECG process **1222**.

[0064] At stage **1240**, a decision is made to confirm that the P-wave has been identified in stage **1236**. If not, the method **1200** proceeds to stage **1242**, wherein data regarding the QRS location identified at stage **1230** is passed to a new procedure at stage **1244**. Indeed, at stage **1244**, the P-wave is again identified, but it is identified in the intravascular ECG signal data **1212**, using the time-stamped location of the identified QRS complex of the external ECG signal data **1210** from stage **1230**. Again note that, because both the external and intravascular ECG data **1210**, **1212** are measurements of the electrical activity of the SA node of the patient's heart, they are time-synchronized despite being detected via different apparatus (i.e., the external electrodes **136** for the external ECG signal data, and the stylet sensor assembly of the stylet **130** for the intravascular ECG signal data). Thus, identification of the QRS complex of an ECG complex from the external ECG signal data **1210** will correspond in time/location to a QRS complex or other component of the corresponding ECG complex in the intravascular ECG signal data **1212**.

[0065] At stage **1246** it is determined whether the intravascular P-wave (identified from the intravascular ECG signal data **1212**) has been successfully identified in stage **1244**. If the answer is "no," the process forwards a "no report" signal to the system **10** at stage **1248**. If the answer at stage **1246** is "yes" as to successful identification of the intravascular P-wave, the time-stamped location of the intravascular P-wave is forwarded at stage **1250** to the intravascular ECG process **1224**. Alternatively, if the answer at stage **1240** is "yes" as to successful identification of the external P-wave, the stages **1242**, **1244**, and **1246** are skipped, as seen in FIG. 6, and the time-stamped external P-wave (identified from the external ECG signal data **1210**) is forwarded at stage **1250** to the intravascular ECG process **1224**. In one embodiment, time-stamping data regarding various aspects of the P-wave are forwarded, including time of P-wave onset, P-wave peak (or maximum amplitude), and P-wave offset.

[0066] Upon receipt of the P-wave location (via identification thereof in the external ECG signal data **1210** at stage **1236** or in the intravascular ECG signal data **1212** at stage **1244**) from stage **1250**, the intravascular ECG process **1224** begins at stage **1260** by performing a frequency analysis of the P-wave as detected by the internal ECG sensor. In the present embodiment and as executed by the processor **22** (FIG. 1) or other suitable processing component, stage **1260** includes analyzing the P-wave in the frequency domain to determine whether it meets or exceeds a predetermined threshold value. In one embodiment, the frequency of the P-wave can be thought of as the inclined slope of the P-wave in the time domain.

[0067] At stage **1264**, an amplitude analysis of the P-wave is also performed in the time domain to determine whether it meets or exceeds a predetermined threshold value. In the present embodiment, the P-wave is determined to be at a maximum when it possesses the following threshold values: an amplitude of between about 250 microvolts and about 1500 microvolts at or above about 20 Hz; and a frequency (inclined slope) range between: exceeding about 10 microvolts per millisecond when the P-wave amplitude is at about 250 microvolts and exceeding 60 microvolts per millisecond when the P-wave amplitude is at about 1500 microvolts. Of

course, other ranges and values can be used in other embodiments according to application, desired sensitivity, intended target location, etc.

[0068] At stage **1262** an analysis is performed to determine whether noise in the intravascular ECG signal data **1212** exceeds acceptable levels such that reliable P-wave determination is impossible. In detail, the process **1224** at stage **1262** reports a value related to the level of noise encountered. In the present embodiment, the threshold noise values include: the maximum level of high frequency (i.e., greater than about 20 Hz) noise present between the offset, or end, of the QRS complex of an ECG complex and onset, or beginning, of the P-wave of the successive ECG complex is less than about 35 microvolts, with a ratio of the maximum level of high frequency noise to the maximum amplitude of the high frequency component of the P-wave in the current ECG complex is less than about 50%. Other noise values can be employed by the process **1224** in determining acceptable noise threshold levels.

[0069] At stage **1266**, it is determined whether an elevated, or maximum P-wave in the ECG complex, such as that seen at **1176P** in the ECG complex **1176** of FIG. 7, has been identified. This is done by determining whether the above-discussed P-wave frequency, amplitude and noise threshold values (determined in stages **1260**, **1264**, and **1262**, respectively) have each been met. If one or more have not been met, the process forwards a "no report" signal to the system **10** at stage **1248**.

[0070] If each of the above threshold values of stages **1260**, **1262**, and **1264** has been met, stage **1266** reports a "yes" and stage **1268** is executed, wherein a deflection analysis of the P-wave is performed. FIG. 8 shows a P-wave portion of the ECG complex **1176** as including a deflection portion **1278**, or negative P-wave component that dips below the isoelectric line **1176A** before rising to form the inflected portion **1276**—the portion of the P-wave rising above the isoelectric line of the P-wave. Stage **1268** analyzes the P-wave for such a deflection. In the present embodiment, stage **1268** is performed by dividing the amplitude of the deflection portion **1278** of the P-wave by the inflected portion **1276** of the P-wave, which yields a deflection percentage. The value of the deflection percentage enables the system **10** to determine the proximity of the intravascular ECG sensor (implemented as the stylet ECG sensor assembly of the stylet **130** at the stylet distal tip), and hence the catheter distal tip, to the SA node.

[0071] In the present embodiment, a deflection value of about 0% indicates that there is substantially no deflection of the P-wave and that the stylet distal tip is at or near a lower $\frac{1}{3}^{rd}$ portion **1354** of a SVC **1352** near a heart **1350** of the patient vasculature, referred to by the process **1224** as zone **1**, shown in FIG. 12. A deflection value of greater than about 0% but less than or equal to about 10% indicates that the P-wave is minimally deflected and that the stylet distal tip has passed but is near the lower $\frac{1}{3}^{rd}$ portion **1354** of the SVC **1352**, referred to by the process **1224** as zone **2**. A deflection value of greater than about 10% indicates that the P-wave is significantly deflected and that the stylet distal tip is well past the lower $\frac{1}{3}^{rd}$ portion **1354** of the SVC **1352**, referred to by the algorithm as zone **3**. Note that FIG. 12 illustrates that additional zones can be defined and reported by the process **1224** according to its analysis of the detected P-wave characteristics. Indeed, FIG. 12 shows that a variety of zones can be defined, such as a range extending from -2 to $+4$, which are equally spaced at varying distances from the lower $\frac{1}{3}^{rd}$ por-

tion 1354 of the SVC 1352. Of course, other zones and spacings can also be defined as part of the method 1200.

[0072] The zone assigned by the process 1224 is reported to a system application 1218 of the system 10 at stage 1270. In one embodiment, the system application 1218 includes a controlling firmware or software application as executed by the processor 22 (FIG. 1) or other suitable component of the system 10. Note that in one embodiment the same processor, such as the processor 22 of the system console 20 (FIG. 1), can be employed to execute both the method 1200 and the system application 1218. The above-described three zones, indicating proximity of the catheter distal end to the patient heart 1350 (FIG. 12) can be reported in stage 1270 to the system application 1218. Additional zones can also be defined and reported, in another embodiment. The system application 1218 can then use the reporting of such zones to convey pertinent information to the user of the system 10 to assist the user in placing the catheter at a desired location within the vasculature, as described further below.

[0073] The above-described method 1200 is iteratively executed in the present embodiment so as to evaluate successive ECG complexes of the patient as detected by the system 10. In other embodiments, non-iterative operation is possible. Once a sufficient number of zone reports (i.e., reports of the zone in which the stylet distal tip is located with respect to the patient heart) according to the analysis of the P-wave by the method 1200 are received by the system application 1218 of the system 10 (via stages 1270 and/or 1248), the display 30 (FIGS. 1, 2) can be updated to indicate the reported zone, if any, and assist the clinician in determining when the distal tip of the catheter or other suitable medical device has reached the desired intravascular location.

[0074] In light of the above, FIGS. 10A-10C show various examples of the depiction of the zone reports provided by the method 1200 of FIG. 6 to the system application 1218, on the display 30 of the system 10 (FIGS. 1, 2). In particular, FIGS. 10A-10C show various depictions, or screenshots 1320 of the display 30 during use of the system 10 to guide and place a catheter within the vasculature of a patient. As shown in FIG. 10A, an external ECG trace 1322 is present, as detected by the external ECG signal sensor component, which in the present embodiment includes the external electrodes 136, as described further above. An intravascular ECG trace 1324 is also depicted, as detected by the intravascular ECG signal sensor component, which in the present embodiment includes the stylet ECG sensor assembly of the stylet 130.

[0075] A sensor image 1326 is also shown, which represents the sensor 50 (FIGS. 1, 2) and its detection of the stylet distal tip. A stylet position icon 1328 is shown superimposed on the sensor image 1326 to indicate position of the stylet distal tip via magnet tracking in TLS mode, ECG tracking in the ECG mode just described, or a combination of both. Note that the icon 1328 in FIG. 10A includes a bullseye configuration, indicating that the system while in ECG tracking mode has not yet detected the stylet distal tip as having arrived at zone 1 proximate the lower $\frac{1}{3}^{rd}$ portion 1354 of the SVC 1352 (FIG. 12).

[0076] FIG. 10B shows the screenshot 1320 with the sensor image 1326 increased in size, which is an option selectable by the clinician or automatically performed by the system 10, in one embodiment. Note that the stylet position icon 1328 has changed to a diamond, which can be colored green, indicating that the system 10 has determined that the stylet distal tip is

located within either zone 1 or 2 (FIG. 12), as reported to the system by the process 1224 (FIG. 6).

[0077] In FIG. 10C and according to one embodiment, the P-wave portions of the ECG complexes shown in the external and internal ECG traces 1322, 1324 of the screenshot 1320 are highlighted, such as by color, for clinician convenience. FIG. 10C shows that if the stylet distal tip is advanced beyond the lower $\frac{1}{3}^{rd}$ portion 1354 of the SVC 1352 the process 1224 of the method 1200 would report a zone 3. This, in turn, causes the stylet position icon 1328 to change from a green diamond to a red octagon, indicating that further advancement of the stylet 130 and catheter 72 should stop. Of course, other colors, shapes, designs, and configurations for the stylet position icon can be employed by the system 10. Indeed, further examples of position icons that can be employed are found in U.S. Patent Application Publication No. 2014/0188133, filed Mar. 7, 2014, and entitled "Iconic Representations for Guidance of an Indwelling Medical Device," which is incorporated herein by reference in its entirety.

[0078] FIG. 9 shows a zone reporting decision tree 1280 that is employed in the present embodiment by the system application 1218 to determine when changing/updating of the display 30 is warranted so as to accurately reflect the position of the stylet distal tip, and hence the catheter distal tip. During execution of the method 1200 (FIG. 6) while the stylet 130 and catheter 72 are advanced within the patient vasculature, the display 30 will depict the stylet position icon 1328 as a yellow-colored bullseye, such as that seen in FIG. 10 on the sensor image 1326, when no zone has been reported to the system application 1218 by the process 1224. This situation corresponds to block 1282, marked "Y1" to indicate the yellow icon color. Note that in the present embodiment the method 1200 will iteratively report a zone (stage 1270 in FIG. 6) or a no zone (stage 1248) to the system application 1218 during execution of the method and operation of the system 10.

[0079] When the process 1224 reports a zone 1 or 2 to the system application 1218 (FIG. 6), advancement from Y1 block 1282 to block 1284, which is marked "G1" to indicate an initial green state, occurs. When the process 1224 iteratively reports a second successive zone 1 or 2, advancement is made from G1 block 1284 to block 1286, which is marked "G2" to indicate a green state. This corresponds to the stylet position icon 1328 being changed from the yellow bullseye icon of FIG. 10A to a green diamond icon as seen in FIG. 10B.

[0080] Should the process 1224 then report a zone 3 or greater to the system application 1218, advancement from the G2 block 1286 to block 1288, which is marked "R1" to indicate an initial red state, occurs. If the process 1224 iteratively reports a second successive zone 3 or greater, advancement is made from R1 block 1288 to block 1290, which is marked "R2" to indicate a red state. This corresponds to the stylet position icon 1328 being changed from the green diamond of FIG. 10B to the red octagon as seen in FIG. 10C.

[0081] Should the process 1224 then report a zone 1 or 2 to the system application 1218, advancement from the R2 block 1290 back to the G1 block 1284 is made to proceed as described above. This—as well as similar advancement to the G1 block 1284 from the R1 block 1288 or the Y1 block 1282—is indicated by the arrows 1294. Correspondingly, advancement to the R1 block 1288 from blocks 1282, 1284, or 1286 is indicated by the arrows 1296.

[0082] On any of the blocks 1282, 1284, 1286, 1288, and 1290, the lack of any reporting from the process 1224 for a

period of less than three seconds causes the system application 1218 to remain on the same designated block. This is indicated by the looped arrows 1292 adjacent each of the blocks 1282, 1284, 1286, 1288, and 1290.

[0083] On any of the blocks 1282, 1284, 1286, 1288, and 1290, the lack of any reporting from the process 1224 for a period equal to or more than three seconds causes the system application 1218 to revert to the Y1 block 1282, with the corresponding change of the stylet position icon 1328. This is indicated by the dashed arrows 1302 leading to the Y1 block 1282 from the blocks 1284, 1286, 1288, and 1290.

[0084] On the G2 block 1286 and the R2 block 1290, continued reporting from the process 1224 of the same zone causes the system application 1218 to remain on the same designated block. This is indicated by the looped arrows 1298 and 1300 for the G2 block 1286 and the R2 block 1290, respectively.

[0085] FIG. 13 shows a zone reporting decision tree 1400 that is employed in one embodiment by the system application 1218 to determine when changing/updating of the display 30 is warranted so as to accurately reflect the position of the stylet distal tip, and hence the catheter distal tip, during catheter insertion and positioning. In particular, the method 1400 is executed in one embodiment by the system application 1218 in deciding how and when to update the depiction on the display 30, including the stylet position icon 1328 (see FIGS. 10A-10C), based on the zone reports 1248, 1270 of the P-wave output 1216A of the process 1224.

[0086] Method 1400 begins at stage 1402 by querying the zone report data (also referred to as a “data set”) provided to the system application 1218 by the process 1224 via P-wave output 1216A. Each zone report in the zone report data includes either a no-zone indication or one of three zone indications: low, high, and ideal, as described further below. In stage 1404 it is determined whether the query count, or number of zone reports provided to the system application 1218, is equal to or greater than 50. If not, stage 1406 is executed, which adds another query, or zone report, at stage 1402.

[0087] If the query count at stage 1404 yields 50 or more in quantity, stage 1408 is executed, wherein the latest zone report is examined to determine whether it reports a zone (corresponding to a “zone reported” at stage 1270 in FIG. 6) or if it reports a “no-zone” (corresponding to a “no zone reported” at stage 1248 in FIG. 6). If the latest zone report is a no-zone, stage 1410 is executed, wherein a no-zone counter is increased by one and the number of consecutive no-zones is counted. Then, at stage 1412, it is determined whether the number of counted consecutive no-zones is equal to or greater than 20. If not, then stage 1406 is executed, which adds another query, or zone report, to stage 1402. If the answer at stage 1412 is “yes,” a zone counter is reset to zero at stage 1414, a high state is declared at stage 1432, in which the system application 1218 will depict an appropriate indication on the display 30 (FIG. 2), for instance, indicating to the user that the catheter can be advanced further and has not yet arrived at the desired destination, in this case, the lower $\frac{1}{3}^{rd}$ portion 1354 of the SVC 1352. In one embodiment, the depiction on the display 30 includes the yellow bullseye design of the stylet position icon 1328 as seen in FIG. 10A. Once the depiction is displayed, the method 1400 reverts to stage 1406 then stage 1402, wherein zone report data are queried anew. In one embodiment, previously stored query data are dis-

posed and new data are acquired. The above-described process is iterative with respect to the no-zone reporting.

[0088] Note that in the present embodiment, the query count of 50 in stage 1404 corresponds to approximately five seconds of data as captured by the system 10 and the method 1200 (FIG. 6), that is, 500 hertz data rate received by the TLS sensor 50 processed in blocks of 50, yielding 10 zone determinations per second. The buffer used to store the data of stage 1402 operates on a first-in, first-out (“FIFO”) basis, ejecting the oldest value in the buffer as a new value is received.

[0089] If, at stage 1408 the latest zone report reports a zone, stage 1416 is executed, wherein the no-zone counter is reset to zero and control advances to stage 1418. At stage 1418, the data is analyzed, beginning with the most recent zone reports, and at stake stage 1420, it is determined whether at least five zone reports are present in the queried zone report data from stage 1402 (the at least five zone reports need not be consecutive in the data). If not, the method reverts to stage 1406, wherein another query is added to stage 1402 and the method proceeds from there.

[0090] If the answer at stage 1420 is “yes,” stage 1422 is executed, wherein the at least five zone reports are analyzed and at stage 1424, it is determined whether four or more of the zone reports are “low” zone reports, indicating that the distal tip of the stylet 130 has passed the lower $\frac{1}{3}^{rd}$ portion 1354 of the SVC 1352 (as in zones +3, +4 of FIG. 12). If yes, a low state is declared at stage 1426, in which the system application 1218 will depict an appropriate indication on the display 30 (FIG. 2), for instance, indicating to the user that the catheter has been advanced too far. In one embodiment, the depiction on the display 30 includes the red octagon design of the stylet position icon 1328 as seen in FIG. 10C. Once the depiction is displayed, the method 1400 reverts to stage 1406 then stage 1402, wherein zone report data are queried anew. In one embodiment, previously stored query data are disposed and new data are acquired.

[0091] If the answer at stage 1424 is “no,” stage 1428 is executed, wherein the at least five zone reports are analyzed and at stage 1430, it is determined whether three or more of the zone reports are “high” zone reports, indicating that the distal tip of the stylet 130 has not yet arrived proximate the lower $\frac{1}{3}^{rd}$ portion 1354 of the SVC 1352 (as in zones -2, -1, or 0 of FIG. 12). If yes, a high state is declared at stage 1432, in which the system application 1218 will depict an appropriate indication on the display 30 (FIG. 2), for instance, indicating to the user that the catheter can be advanced further. In one embodiment, the depiction on the display 30 includes the yellow bullseye design of the stylet position icon 1328 as seen in FIG. 10A. Once the depiction is displayed, the method 1400 reverts to stage 1406 then stage 1402, wherein zone report data are queried anew. In one embodiment, previously stored query data are disposed and new data are acquired.

[0092] If the answer at stage 1430 is “no,” stage 1434 is executed, wherein the at least five zone reports are analyzed and at stage 1436, it is determined whether four or more of the zone reports are “ideal” zone reports, indicating that the distal tip of the stylet 130 has arrived proximate the lower $\frac{1}{3}^{rd}$ portion 1354 of the SVC 1352 (as in zones +1 or +2 of FIG. 12). If yes, an ideal state is declared at stage 1438, in which the system application 1218 will depict an appropriate indication on the display 30 (FIG. 2), for instance, indicating to the user that the catheter has arrived at its intended destination

according to the present embodiment. In one embodiment, the depiction on the display 30 includes the green diamond design of the stylet position icon 1328 as seen in FIG. 10B. Once the depiction is displayed, the method 1400 reverts to stage 1406 then stage 1402, wherein zone report data are queried anew. In one embodiment, previously stored query data are disposed and new data are acquired.

[0093] If the answer at stage 1436 is “no,” stage 1440 is executed, wherein the at least five current zone reports are analyzed and a decision made at one or more of three stages 1440, 1442, and 1444. At stage 1440, if the previous zone determination on an immediately prior iteration of the method 1400 yielded an ideal state and three of the five current zone reports are low zone reports, then a low state is declared at stage 1426, which stage is executed as already described further above.

[0094] If the answer at stage 1440 is “no,” stage 1442 is executed, wherein if the previous zone determination on the immediately prior iteration of the method 1400 yielded an ideal state and two or more of the five current zone reports are ideal zone reports, then an ideal state is declared at stage 1438, which stage is executed as already described further above.

[0095] If the answer at stage 1442 is “no,” stage 1444 is executed, wherein if the previous zone determination on the immediately prior iteration of the method 1400 yielded a low state and two or more of the five current zone reports are low zone reports, then a low state is declared at stage 1426, which stage is executed as already described further above.

[0096] If the answer at stage 1444 is “no,” a high state is declared at stage 1432, which stage is executed as described further above. Once the depiction is displayed pursuant stages 1426, 1432, or 1438, the method 1400 reverts to stage 1406 then stage 1402, wherein zone report data are queried anew. In one embodiment, previously stored query data are disposed and new data are acquired.

[0097] Note that the method 1400 is iteratively run during the medical device placement process using the system 10. Note also that the particular threshold numbers used in evaluating the zone reports can vary from what is described herein as may be appreciated by one skilled in the art. Also, more than three zone reports can be employed, in one embodiment.

[0098] Note that other modes for updating the display 30 according to zone information reported by the method 1200 can also be employed, including different icons or symbols or output modes, differently colored icons, etc. More generally, other reporting decision trees can be utilized to govern depiction of zone information from the method 1200 on the display 30 or other output mode by the system application 1218. In yet another embodiment, parameters other than zones can be reported by the method 1200.

[0099] Note that the stages 1260-1264 of the process 1224 can be performed simultaneously or in an order different than that shown in FIG. 6. Also, other parameters can be evaluated by the algorithm of the method 1200, including patient heart rate, isoelectric/baseline wander, and the uprightiness of the detected QRS complex. For example, a patient heart rate threshold of between about 50 and about 150 beats per minute can be used as a parameter for evaluation by the method 1200 to ensure proper intravascular placement of the medical device. In another example, an allowable baseline wander of +/-about 300 microvolts at 2.5 Hertz can be used as a parameter. In yet another example, a QRS complex length between about 0.08 and about 0.10 seconds in duration can be used as

a parameter. These and other suitable parameters can be employed. Generally, it is noted that more or fewer stages can be included in the method 1200 in other embodiments to assist in tracking and positioning the catheter or other suitable medical device.

[0100] FIG. 11 shows the method 1200 according to another embodiment, wherein instead of both external and intravascular ECG sensor components used to determine P-wave maximum, only the intravascular ECG sensor component is employed. As such, no external electrodes, such as the external electrodes 136 (FIG. 2), are disposed on the skin of the patient. Instead, stages 1230, 1232, 1234, 1236, and 1240 are executed by using a baseline ECG signal. The baseline ECG signal is acquired using ECG signals detected by the stylet sensor assembly of the stylet 130 (i.e., the intravascular ECG sensor component). In particular, the baseline ECG signal is acquired from the stylet ECG sensor assembly of the stylet 130 when the stylet distal tip is disposed in the vasculature between the insertion site 73 (FIG. 2) and about the shoulder region of the arm into which the stylet and catheter 72 are inserted (i.e., the right arm in the example shown in FIG. 2). Note that, in another embodiment, the insertion site can be on another limb of the patient, such as the leg, in which case the baseline ECG signal is acquired from the stylet ECG sensor assembly when the stylet distal tip is disposed between the insertion site and the junction point of the limb (leg) with the torso of the patient.

[0101] Detection of ECG signals when the stylet sensor assembly is positioned as described immediately above (with the insertion site disposed on the arm of the patient) approximates the detection of ECG signals from a pair of external skin-placed electrodes in a “Lead II” configuration based on Einthoven’s triangle. As such, the ECG signal so detected will remain substantially static and can be used as a baseline reference ECG signal against the intravascular ECG signal detected by the stylet sensor assembly when the stylet 130 is advanced past the general shoulder region of the arm into which the stylet and catheter are inserted. Such advancement will enable the stylet sensor assembly to detect the changing P-wave as the stylet nears the SA node of the patient heart 1350 (FIG. 12). Thus, in the present embodiment the stages 1230, 1232, 1234, 1236, and 1240 are executed similar to that described further above in connection with the description of FIG. 6 while using the baseline ECG signal (part of the intravascular ECG signal data 1212) detected by the stylet sensor assembly upon initial insertion of the catheter 72 and included stylet 130 into the vasculature but before advancement past the shoulder region of the arm into which the catheter and stylet are inserted.

[0102] Note that the use and analysis of a baseline and intravascular ECG signal that both originate from detection by an intravascular ECG sensor component (i.e., the stylet sensor assembly of the stylet 130) as described in connection with FIG. 11 enables in one embodiment the ability for a clinician to observe conditions that may be evident only in the intravascular ECG signal and not evident in an external ECG signal detected via an external ECG sensor component, such as the external electrodes 136 of FIG. 2. One example of such a condition includes intra-atrial blocks, for instance.

[0103] Embodiments disclosed herein may include a special purpose or general-purpose computer including computer hardware, as discussed in greater detail below. Embodiments within the scope of the present disclosure also include computer-readable media for carrying or having computer-

executable instructions or data structures stored thereon. Such computer-readable media can be any available media that can be accessed by a general purpose or special purpose computer. By way of example, and not limitation, computer-readable media can comprise physical (or recordable-type) computer-readable storage media, such as, RAM, ROM, EEPROM, CD-ROM or other optical disk storage, solid-state storage, magnetic disk storage or other magnetic storage devices, or any other medium which can be used to store desired program code means in the form of computer-executable instructions or data structures and which can be accessed by a general purpose or special purpose computer.

[0104] In this description and in the following claims, a “network” is defined as one or more data links that enable the transport of electronic data between computer systems and/or modules. When information is transferred or provided over a network or another communications connection (either hardwired, wireless, or a combination of hardwired or wireless) to a computer, the computer properly views the connection as a computer-readable medium. Thus, by way of example, and not limitation, computer-readable media can also comprise a network or data links which can be used to carry or store desired program code means in the form of computer-executable instructions or data structures and which can be accessed by a general purpose or special purpose computer.

[0105] Computer-executable instructions include, for example, instructions and data which cause a general purpose computer, special purpose computer, or special purpose processing device to perform a certain function or group of functions. The computer executable instructions may be, for example, binaries, intermediate format instructions such as assembly language, or even source code. Although the subject matter has been described in language specific to structural features and/or methodological acts, it is to be understood that the subject matter defined in the appended claims is not necessarily limited to the described features or acts described above. Rather, the described features and acts are disclosed as example forms of implementing the claims.

[0106] Those skilled in the art will appreciate that the embodiments herein may be practiced in network computing environments with many types of computer system configurations, including personal computers, desktop computers, laptop computers, message processors, hand-held devices, multi-processor systems, microprocessor-based or programmable consumer electronics, network PCs, minicomputers, mainframe computers, mobile telephones, PDAs, pagers, and the like. The embodiments may also be practiced in distributed system environments where local and remote computer systems, which are linked (either by hardwired data links, wireless data links, or by a combination of hardwired and wireless data links) through a network, both perform tasks. In a distributed system environment, program modules may be located in both local and remote memory storage devices.

[0107] Embodiments of the invention may be embodied in other specific forms without departing from the spirit of the present disclosure. The described embodiments are to be considered in all respects only as illustrative, not restrictive. The scope of the embodiments is, therefore, indicated by the appended claims rather than by the foregoing description. All changes that come within the meaning and range of equivalence of the claims are to be embraced within their scope.

What is claimed is:

1. A method for guiding a medical device to a desired location within a vasculature of a patient, the method comprising:

detecting an intravascular ECG signal of the patient; identifying a P-wave of a waveform of the intravascular ECG signal, the P-wave varying according to proximity of the medical device to the desired location; determining whether the identified P-wave is elevated; determining a deflection value of the identified P-wave when the identified P-wave is elevated; and reporting information relating to a location of the medical device within the vasculature of the patient at least partially according to the determined deflection value of the elevated P-wave.

2. The method for guiding as defined in claim 1, further comprising:

detecting an external ECG signal of the patient; identifying an external P-wave of a waveform of the external ECG signal; and using the identified external P-wave in identifying the P-wave of the intravascular ECG signal.

3. The method for guiding as defined in claim 2, wherein identifying the external P-wave further includes:

identifying a QRS complex of the waveform of the external ECG signal; identifying a T-wave of the waveform of the external ECG signal; and determining a RR interval between successive waveforms of the external ECG signal.

4. The method for guiding as defined in claim 3, wherein the external ECG signal is detected by a pair of external electrodes placed on a skin of the patient.

5. The method for guiding as defined in claim 1, wherein the intravascular ECG signal is detected by a sensor component included with a stylet removably received within the medical device.

6. The method for guiding as defined in claim 1, wherein identifying a P-wave, determining whether the identified P-wave is elevated, and determining the deflection value are executed by a processor of a system operably connected with the medical device.

7. The method for guiding as defined in claim 6, wherein identifying a P-wave, determining whether the identified P-wave is elevated, and determining the deflection value are executed iteratively by the processor.

8. The method for guiding as defined in claim 1, wherein the medical device includes a catheter and wherein the desired location is proximate a lower portion of a superior vena cava of a heart of the patient.

9. The method for guiding as defined in claim 1, wherein reporting information relating to the location of the medical device includes reporting one of a plurality of zones, each zone relating to a proximity of the medical device to a signal-emitting node of a heart of the patient.

10. The method for guiding as defined in claim 1, wherein reporting information relating to a location of the medical device includes outputting the information to at least one of an audio device and a display device.

11. The method for guiding as defined in claim 1, wherein reporting information relating to a location of the medical device includes outputting graphical information to a display device of a placement system for the medical device.

12. The method for guiding as defined in claim **11**, wherein the graphical information includes a plurality of icons that correspond to a proximity of the medical device to a signal-emitting node of a heart of the patient.

13. A method for guiding a medical device to a desired location within a vasculature of a patient, the method comprising:

detecting an intravascular ECG signal of a signal-emitting portion of a heart of the patient by an intravascular ECG sensor component included with the medical device; and determining whether a P-wave of a waveform of the intravascular ECG signal is elevated based on a plurality of predetermined thresholds, the P-wave varying according to a distance of the intravascular ECG sensor component from the signal-emitting portion of the heart, the predetermined thresholds relating to at least one of the following:

- (a) an amplitude of the P-wave of the intravascular ECG signal within a predetermined range;
- (b) a slope of the P-wave of the intravascular ECG signal within a predetermined range; and
- (c) a noise component of the intravascular ECG signal within a predetermined range.

14. The method for guiding as defined in claim **13**, further comprising:

determining a deflection value of the P-wave when the P-wave is elevated; and

reporting information relating to a location of the medical device within the vasculature of the patient at least partially according to the determined deflection value of the P-wave.

15. The method for guiding as defined in claim **13**, wherein detecting the intravascular ECG signal, determining whether the P-wave is elevated, and determining the deflection value are performed iteratively.

16. A system for guiding a medical device to a desired location within a vasculature of a patient, comprising:

at least an intravascular ECG sensor for detecting an intravascular ECG signal of the patient;

a processor that receives the intravascular ECG signal, the processor:

identifying a P-wave of a waveform of the intravascular ECG signal, the P-wave varying according to proximity of the medical device to the desired location; determining whether the identified P-wave is elevated; determining a deflection value of the identified P-wave when the identified P-wave is elevated; and

reporting information relating to a location of the medical device within the vasculature of the patient at least partially according to the determined deflection value of the elevated P-wave; and

an output device that reports the information relating to the location of the medical device.

17. The system for guiding as defined in claim **16**, wherein the processor determining whether the identified P-wave is elevated further includes at least one of:

determining whether at least one of a frequency and an amplitude of the identified falls within a predetermined range; and

determining whether a noise component of the intravascular ECG signal falls within a predetermined range.

18. The system for guiding as defined in claim **16**, wherein the output device includes a display of the system.

19. The system for guiding as defined in claim **18**, wherein the processor executes a decision tree, the decision tree determining when to report the information relating to the location of the medical device.

20. The system as defined in claim **19**, wherein the medical device placement system further includes at least one of a magnet tracking modality and an ultrasound imaging modality.

21. In a guidance system including a medical device for insertion into a vasculature of a patient, an external ECG sensor component, and an intravascular ECG sensor component included with the medical device, a method for guiding the medical device, the method comprising:

- (a) identifying a P-wave from a waveform of an intravascular ECG signal from the intravascular ECG sensor component after insertion of the medical device into the vasculature;
- (b) determining whether at least one of a frequency and an amplitude of the identified P-wave falls within a predetermined range;
- (c) determining whether a noise component of the intravascular ECG signal falls within a predetermined range; and
- (d) determining whether the identified P-wave is at an elevated state based upon the determinations of stages (b) and (c).

22. The method for guiding as defined in claim **21**, further comprising:

- (e) determining a deflection value for the identified P-wave when the identified P-wave is at an elevated state as determined in stage (d).

23. The method for guiding as defined in claim **22**, further comprising:

- (f) depicting a position of the medical device based on the deflection value as determined in stage (e).

24. The method for guiding as defined in claim **23**, wherein a processor of the system executes a decision tree, the decision tree determining an aspect of depicting the position of the medical device.

25. The method for guiding as defined in claim **24**, wherein the decision tree iteratively queries a data set of a plurality of zone reports until at least 50 zone reports are acquired.

26. The method for guiding as defined in claim **24**, wherein the processor depicts the position of the medical device when at three of five zone reports from the data set are identical.

27. The method for guiding as defined in claim **21**, further comprising:

identifying an external P-wave of a waveform of an external ECG signal from the external ECG sensor component; and

using the identified external P-wave to identify the P-wave of the intravascular ECG signal in stage (a).

28. A method for guiding a catheter to a desired location within a vasculature of a patient, the method comprising:

inserting a distal portion of the catheter into the vasculature via an insertion site on a limb of the patient;

detecting a baseline ECG signal of the patient via an ECG sensor included with the catheter, the baseline ECG signal being detected when the distal portion of the catheter is disposed between the insertion site and a junction point of the limb with the torso of the patient;

attempting to identify a baseline P-wave of a waveform of the baseline ECG signal;

identifying an intravascular P-wave of a waveform of an intravascular ECG signal, the intravascular ECG signal being detected when the distal portion of the catheter is disposed at a location distal to the junction point of the limb, the intravascular P-wave varying according to proximity of the catheter to the desired location;

determining whether the identified intravascular P-wave is elevated;

determining a deflection value of the identified intravascular P-wave when the identified intravascular P-wave is elevated; and

reporting information relating to a location of the catheter within the vasculature of the patient at least partially according to the determined deflection value of the elevated identified intravascular P-wave.

29. The method for guiding as defined in claim **28**, wherein identifying the intravascular P-wave is at least partially is executed using information relating to the identification of the baseline P-wave.

* * * * *

专利名称(译)	用于引导和放置血管内装置的系统和方法		
公开(公告)号	US20150216446A1	公开(公告)日	2015-08-06
申请号	US14/615932	申请日	2015-02-06
申请(专利权)人(译)	C. R. BARD , INC.		
当前申请(专利权)人(译)	C. R. BARD , INC.		
[标]发明人	BUKHMANN VLADISLAV MISENER ANTHONY K VASSYLYEV VALERIY URRY ROBIN S TANNER BRIAN S		
发明人	BUKHMANN, VLADISLAV MISENER, ANTHONY K. VASSYLYEV, VALERIY URRY, ROBIN S. TANNER, BRIAN S.		
IPC分类号	A61B5/06 A61B5/04 A61B8/08 A61B5/0452 A61B5/00		
CPC分类号	A61B5/062 A61B5/0452 A61B5/6824 A61B5/6823 A61B5/04012 A61B5/7405 A61B5/743 A61B8/0841 A61B5/6847 A61B5/04085 A61B5/042 A61B5/061 A61B5/065 A61B8/085		
优先权	61/936825 2014-02-06 US		
其他公开文献	US9839372		
外部链接	Espacenet USPTO		

摘要(译)

公开了一种用于辅助临床医生将导管或其他医疗装置放置在患者的脉管系统内的引导和放置系统以及相关方法。在一个实施例中，还公开了一种用于将医疗设备引导到患者的脉管系统内的期望位置的方法，并且包括检测患者的血管内ECG信号并识别血管内ECG信号的波形的P波，其中P波根据医疗设备与所需位置的接近度而变化。该方法还包括确定所识别的P波是否升高，当识别出的P波升高时确定所识别的P波的偏转值，并且至少报告与医疗装置在患者脉管系内的位置有关的信息。部分地根据确定的升高的P波的偏转值。

