



US009549685B2

(12) **United States Patent**
Cox et al.

(10) **Patent No.:** **US 9,549,685 B2**
(45) **Date of Patent:** **Jan. 24, 2017**

(54) **APPARATUS AND DISPLAY METHODS
RELATING TO INTRAVASCULAR
PLACEMENT OF A CATHETER**

(71) Applicant: **C. R. Bard, Inc.**, Murray Hill, NJ (US)

(72) Inventors: **Jeremy B. Cox**, Salt Lake City, UT
(US); **Christian W. Crook**, West
Jordan, UT (US)

(73) Assignee: **C. R. Bard, Inc.**, Murray Hill, NJ (US)

(*) Notice: Subject to any disclaimer, the term of this
patent is extended or adjusted under 35
U.S.C. 154(b) by 7 days.

(21) Appl. No.: **14/498,887**

(22) Filed: **Sep. 26, 2014**

(65) **Prior Publication Data**

US 2015/0018701 A1 Jan. 15, 2015

Related U.S. Application Data

(60) Division of application No. 12/557,401, filed on Sep.
10, 2009, now Pat. No. 8,849,382, which is a
(Continued)

(51) **Int. Cl.**
A61B 5/042 (2006.01)
A61B 5/0472 (2006.01)
(Continued)

(52) **U.S. Cl.**
CPC **A61B 5/0472** (2013.01); **A61B 5/06**
(2013.01); **A61B 5/061** (2013.01); **A61B**
8/0833 (2013.01);
(Continued)

(58) **Field of Classification Search**
CPC **A61B 5/042**; **A61B 5/0472**; **A61B 5/742**
See application file for complete search history.

(56) **References Cited**

U.S. PATENT DOCUMENTS

3,133,244 A 5/1964 Wojtulewicz
3,297,020 A 1/1967 Mathiesen
(Continued)

FOREIGN PATENT DOCUMENTS

AU 642647 11/1990
AU 1860597 B2 6/1999
(Continued)

OTHER PUBLICATIONS

U.S. Appl. No. 13/118,138, filed May 27, 2011 Non-Final Office
Action dated Oct. 3, 2012.

(Continued)

Primary Examiner — William Levicky

(74) *Attorney, Agent, or Firm* — Rutan & Tucker, LLP

(57) **ABSTRACT**

An integrated catheter placement system for accurately
placing a catheter within a patient's vasculature is disclosed.
In one embodiment, the integrated system comprises a
system console, a tip location sensor for temporary place-
ment on the patient's chest, and an ultrasound probe. The tip
location sensor senses a magnetic field of a stylet disposed
in a lumen of the catheter when the catheter is disposed in
the vasculature. The ultrasound probe ultrasonically images
a portion of the vasculature prior to introduction of the
catheter. ECG signal-based catheter tip guidance is included
in the integrated system to enable guidance of the catheter
tip to a desired position with respect to a node of the
patient's heart. Various aspects for visualizing and manipu-
lating display of the ECG signal data acquired via the
present system, together with aspects of various ECG sensor
configurations, are also disclosed.

13 Claims, 48 Drawing Sheets

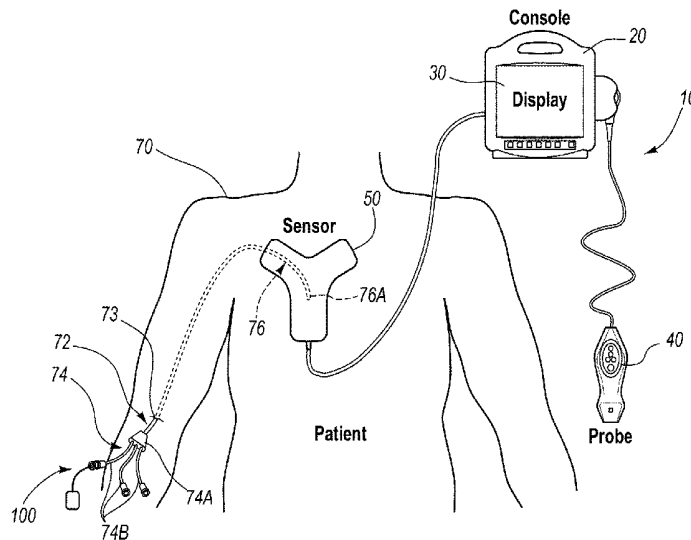

Related U.S. Application Data

	continuation-in-part of application No. 12/426,175, filed on Apr. 17, 2009, which is a continuation-in-part of application No. 12/323,273, filed on Nov. 25, 2008, now Pat. No. 8,388,541.	4,608,989 A	9/1986	Drue
		4,608,992 A	9/1986	Hakim et al.
		4,619,247 A	10/1986	Inoue et al.
		4,622,644 A	11/1986	Hansen
		4,644,960 A	2/1987	Johans
		4,652,820 A	3/1987	Maresca
		4,660,571 A	4/1987	Hess et al.
		4,665,925 A	5/1987	Millar
		4,667,230 A	5/1987	Arakawa et al.
		4,674,518 A	6/1987	Salo
		4,676,249 A	6/1987	Arenas et al.
		4,681,106 A	7/1987	Kensey et al.
		4,681,117 A	7/1987	Brodman et al.
		4,688,578 A	8/1987	Takano et al.
		4,692,148 A	9/1987	Kantrowitz et al.
		4,697,595 A	10/1987	Breyer et al.
		4,700,997 A	10/1987	Strand
		4,706,681 A	11/1987	Breyer et al.
		4,710,708 A	12/1987	Rorden et al.
		4,733,669 A	3/1988	Segal
		4,737,794 A	4/1988	Jones
		4,741,356 A	5/1988	Letzo et al.
		4,742,356 A	5/1988	Kuipers
		4,753,247 A	6/1988	Kirsner et al.
		4,770,185 A	9/1988	Silverstein et al.
		4,771,788 A	9/1988	Millar
		4,781,685 A	11/1988	Lehmann et al.
		4,784,646 A	11/1988	Feingold
		4,787,070 A	11/1988	Suzuki et al.
		4,787,396 A	11/1988	Pidorenko
		4,790,809 A	12/1988	Kuntz
		4,793,361 A	12/1988	DuFault
		4,794,930 A	1/1989	Machida et al.
		4,796,632 A	1/1989	Boyd et al.
		4,798,588 A	1/1989	Aillon
		4,798,598 A	1/1989	Bonello et al.
		4,809,681 A	3/1989	Kantrowitz et al.
		4,809,713 A	3/1989	Grayzel
		4,813,729 A	3/1989	Speckhart
		4,821,731 A	4/1989	Martinelli et al.
		4,836,214 A	6/1989	Sramek
		4,840,182 A	6/1989	Carlson
		4,840,622 A	6/1989	Hardy
		4,841,977 A	6/1989	Griffith et al.
		4,849,692 A	7/1989	Blood
		4,850,358 A	7/1989	Millar
		4,852,580 A	8/1989	Wood
		4,856,317 A	8/1989	Pidorenko et al.
		4,856,529 A	8/1989	Segal
		4,860,757 A	8/1989	Lynch et al.
		4,867,169 A	9/1989	Machida et al.
		4,869,263 A	9/1989	Segal et al.
		4,869,718 A	9/1989	Brader
		4,873,987 A	10/1989	Djordjevich et al.
		4,887,606 A	12/1989	Yock et al.
		4,887,615 A	12/1989	Taylor
		4,889,128 A	12/1989	Millar
		4,899,756 A	2/1990	Sonek
		4,901,725 A	2/1990	Nappholz et al.
		4,905,698 A	3/1990	Strohl, Jr. et al.
		4,911,173 A	3/1990	Terwilliger
		4,911,174 A	3/1990	Pederson et al.
		4,917,669 A	4/1990	Bonaldo
		4,924,870 A	5/1990	Wlodarczyk et al.
		4,943,770 A	7/1990	Ashley-Rollman et al.
		4,945,305 A	7/1990	Blood
		4,947,852 A	8/1990	Nassi et al.
		4,957,110 A	9/1990	Vogel et al.
		4,957,111 A	9/1990	Millar
		4,961,433 A	10/1990	Christian
		4,966,148 A	10/1990	Millar
		4,967,753 A	11/1990	Haase et al.
		4,977,886 A	12/1990	Takehana et al.
		4,989,608 A	2/1991	Ratner
		4,989,610 A *	2/1991	Patton A61B 5/04365 600/508
		4,995,396 A	2/1991	Inaba et al.
		4,998,916 A	3/1991	Hammerslag et al.
		5,004,456 A	4/1991	Botterbusch et al.
(60)	Provisional application No. 61/095,921, filed on Sep. 10, 2008, provisional application No. 61/095,451, filed on Sep. 9, 2008, provisional application No. 61/091,233, filed on Aug. 22, 2008, provisional application No. 61/045,944, filed on Apr. 17, 2008, provisional application No. 60/990,242, filed on Nov. 26, 2007.			
(51)	Int. Cl. <i>A61B 5/06</i> (2006.01) <i>A61B 8/08</i> (2006.01) <i>A61B 5/00</i> (2006.01)			
(52)	U.S. Cl. CPC <i>A61B 8/0841</i> (2013.01); <i>A61B 34/20</i> (2016.02); <i>A61B 5/042</i> (2013.01); <i>A61B 5/742</i> (2013.01); <i>A61B 46/00</i> (2016.02); <i>A61B 90/40</i> (2016.02); <i>A61B 2034/2051</i> (2016.02); <i>A61B 2090/378</i> (2016.02)			
(56)	References Cited U.S. PATENT DOCUMENTS			
	3,625,200 A	12/1971	Muller	
	3,674,014 A	7/1972	Tillander et al.	
	3,817,241 A	6/1974	Grausz	
	3,847,157 A	11/1974	Caillouette et al.	
	3,868,565 A	2/1975	Kuipers	
	3,896,373 A	7/1975	Zelby	
	3,902,501 A	9/1975	Citron et al.	
	3,986,373 A	10/1976	Goodlaxson	
	3,995,623 A	12/1976	Blake et al.	
	4,003,369 A	1/1977	Heilman et al.	
	4,063,561 A	12/1977	McKenna	
	4,072,146 A	2/1978	Howes	
	4,114,601 A	9/1978	Abels	
	4,149,535 A	4/1979	Volder et al.	
	4,173,228 A	11/1979	Steenwyk et al.	
	4,175,566 A	11/1979	Millar	
	4,181,120 A	1/1980	Kunii et al.	
	4,224,949 A	9/1980	Scott et al.	
	4,244,362 A	1/1981	Anderson	
	4,289,139 A	9/1981	Enjoji et al.	
	4,317,078 A	2/1982	Weed et al.	
	4,327,722 A	5/1982	Groshong et al.	
	4,327,723 A	5/1982	Frankhouser	
	4,362,166 A	12/1982	Furler et al.	
	4,365,639 A	12/1982	Goldreyer	
	4,380,237 A	4/1983	Newbower	
	4,407,294 A	10/1983	Vilkomerson	
	4,417,886 A	11/1983	Frankhouser et al.	
	4,429,693 A	2/1984	Blake et al.	
	4,431,005 A	2/1984	McCormick	
	4,431,214 A	2/1984	Buffington	
	4,445,501 A	5/1984	Bresler	
	4,459,854 A	7/1984	Richardson et al.	
	4,469,106 A	9/1984	Harui	
	4,483,343 A	11/1984	Beyer et al.	
	4,491,137 A	1/1985	Jingu	
	4,565,201 A	1/1986	Lass	
	4,572,198 A	2/1986	Codrington	
	4,577,634 A	3/1986	Gessman	
	4,582,067 A	4/1986	Silverstein et al.	
	4,587,975 A	5/1986	Salo et al.	
	4,588,394 A	5/1986	Schulte et al.	
	4,593,687 A	6/1986	Gray	
	4,595,012 A	6/1986	Webler et al.	
	4,601,706 A	7/1986	Aillon	

(56)

References Cited

U.S. PATENT DOCUMENTS

5,005,592 A	4/1991	Cartmell	5,307,072 A	4/1994	Jones, Jr.
5,016,173 A	5/1991	Kenet et al.	5,311,871 A	5/1994	Yock
5,025,799 A	6/1991	Wilson	5,313,949 A	5/1994	Yock
5,029,585 A	7/1991	Lieber et al.	5,318,025 A	6/1994	Dumoulin et al.
5,040,548 A	8/1991	Yock	5,325,860 A	7/1994	Seward et al.
5,042,486 A	8/1991	Pfeiler et al.	5,325,873 A	7/1994	Hirschi et al.
5,045,071 A	9/1991	McCormick et al.	5,330,496 A	7/1994	Alferness
5,046,497 A	9/1991	Millar	5,331,966 A	7/1994	Bennett et al.
5,050,607 A	9/1991	Bradley et al.	5,333,614 A	8/1994	Feiring
5,057,095 A	10/1991	Fabian	5,337,678 A	8/1994	Grout et al.
5,058,583 A	10/1991	Geddes et al.	5,341,807 A	8/1994	Nardella
5,058,595 A	10/1991	Kern	5,343,865 A	9/1994	Gardineer et al.
5,067,489 A	11/1991	Lind	5,345,940 A	9/1994	Seward et al.
5,076,278 A	12/1991	Vilkomerson et al.	5,348,020 A	9/1994	Hutson
5,078,140 A	1/1992	Kwoh	5,350,352 A	9/1994	Buchholtz et al.
5,078,148 A	1/1992	Nassi et al.	5,357,961 A	10/1994	Fields et al.
5,078,149 A	1/1992	Katsumata et al.	5,365,935 A	11/1994	Righter et al.
5,078,678 A	1/1992	Katims	5,366,443 A	11/1994	Eggers et al.
5,078,714 A	1/1992	Katims	5,368,048 A	11/1994	Stoy et al.
5,084,022 A	1/1992	Claude	5,375,596 A	12/1994	Twiss et al.
5,092,341 A	3/1992	Kelen	5,376,083 A	12/1994	Mische
5,099,845 A	3/1992	Besz et al.	5,377,678 A	1/1995	Dumoulin et al.
5,099,850 A	3/1992	Matsui et al.	5,385,053 A	1/1995	Wlodarczyk et al.
5,100,387 A	3/1992	Ng	5,385,146 A	1/1995	Goldreyer
5,105,829 A	4/1992	Fabian et al.	5,391,199 A	2/1995	Ben-Haim
5,109,862 A	5/1992	Kelen et al.	5,394,876 A	3/1995	Ma
5,114,401 A	5/1992	Stuart et al.	5,394,877 A	3/1995	Orr et al.
5,121,750 A	6/1992	Katims	5,395,366 A	3/1995	D'Andrea et al.
5,125,410 A	6/1992	Misono et al.	5,398,683 A	3/1995	Edwards et al.
5,134,370 A	7/1992	Jefferts et al.	5,398,691 A	3/1995	Martin et al.
5,144,955 A	9/1992	O'Hara	5,411,485 A	5/1995	Tennican et al.
5,156,151 A	10/1992	Imran	5,413,107 A	5/1995	Oakley et al.
5,158,086 A	10/1992	Brown et al.	5,417,208 A	5/1995	Winkler
5,160,342 A	11/1992	Reger et al.	5,422,478 A	6/1995	Wlodarczyk et al.
5,161,536 A	11/1992	Vilkomerson et al.	5,423,334 A	6/1995	Jordan
5,174,295 A	12/1992	Christian et al.	5,423,877 A	6/1995	Mackey
5,174,299 A	12/1992	Nelson	5,425,367 A	6/1995	Shapiro et al.
5,184,601 A	2/1993	Putman	5,425,370 A	6/1995	Vilkomerson
5,190,045 A	3/1993	Frazin	5,425,382 A	6/1995	Golden et al.
5,202,985 A	4/1993	Goyal	5,427,114 A	6/1995	Colliver et al.
5,205,830 A	4/1993	Dassa et al.	5,429,132 A	7/1995	Guy et al.
5,211,165 A	5/1993	Dumoulin et al.	5,429,617 A	7/1995	Hammersmark et al.
5,211,636 A	5/1993	Mische	5,431,641 A	7/1995	Grozinger et al.
5,212,988 A	5/1993	White et al.	5,433,729 A	7/1995	Adams et al.
5,214,615 A	5/1993	Bauer et al.	5,437,276 A	8/1995	Takada et al.
5,217,026 A	6/1993	Stoy et al.	5,437,277 A	8/1995	Dumoulin et al.
5,220,924 A	6/1993	Frazin	5,438,873 A	8/1995	Wlodarczyk et al.
5,233,994 A	8/1993	Shmulewitz	5,443,066 A	8/1995	Dumoulin et al.
5,235,987 A	8/1993	Wolfe	5,443,489 A	8/1995	Ben-Haim
5,239,464 A	8/1993	Blair et al.	5,445,150 A	8/1995	Dumoulin et al.
5,240,004 A	8/1993	Walinsky et al.	5,445,166 A	8/1995	Taylor
5,243,995 A	9/1993	Maier	5,450,846 A	9/1995	Goldreyer
5,246,007 A	9/1993	Frisbie et al.	5,453,575 A	9/1995	O'Donnell et al.
5,246,426 A	9/1993	Lewis et al.	5,453,576 A	9/1995	Krivitski
5,247,171 A	9/1993	Wlodarczyk et al.	5,456,256 A	10/1995	Schneider
5,251,635 A	10/1993	Dumoulin et al.	5,456,718 A	10/1995	Szymaitis
5,255,680 A	10/1993	Darrow et al.	5,464,016 A	11/1995	Nicholas et al.
5,257,636 A	11/1993	White	5,474,065 A	12/1995	Meathrel et al.
5,257,979 A	11/1993	Jagpal	5,476,090 A	12/1995	Kishi
5,261,409 A	11/1993	Dardel	5,480,422 A	1/1996	Ben-Haim
5,265,610 A	11/1993	Darrow et al.	5,487,729 A	1/1996	Avellanet et al.
5,265,614 A	11/1993	Hayakawa et al.	5,490,522 A	2/1996	Dardel
5,267,569 A	12/1993	Lienhard	5,492,538 A	2/1996	Johlin, Jr.
5,270,810 A	12/1993	Nishimura	5,494,038 A	2/1996	Wang et al.
5,271,404 A	12/1993	Corl et al.	5,500,011 A	3/1996	Desai
5,273,025 A	12/1993	Sakiyama et al.	5,500,012 A	3/1996	Brucker et al.
5,273,042 A	12/1993	Lynch et al.	5,505,205 A	4/1996	Solomon et al.
5,274,551 A	12/1993	Corby, Jr.	5,509,822 A	4/1996	Negus et al.
5,275,053 A	1/1994	Wlodarczyk et al.	5,513,637 A	5/1996	Twiss et al.
5,279,129 A	1/1994	Ito	5,515,160 A	5/1996	Schulz et al.
5,279,607 A	1/1994	Schentag et al.	5,515,853 A	5/1996	Smith et al.
5,280,786 A	1/1994	Wlodarczyk et al.	5,517,989 A	5/1996	Frisbie et al.
5,287,331 A	2/1994	Schindel et al.	5,522,878 A	6/1996	Montecalvo et al.
5,289,373 A	2/1994	Zarge et al.	5,522,880 A	6/1996	Barone et al.
5,292,342 A	3/1994	Nelson et al.	5,526,812 A	6/1996	Dumoulin et al.
			5,531,664 A	7/1996	Adachi et al.
			5,536,248 A	7/1996	Weaver et al.
			5,540,230 A	7/1996	Vilkomerson
			5,540,681 A	7/1996	Strul et al.

(56)

References Cited

U.S. PATENT DOCUMENTS

5,542,938 A	8/1996	Avellanet et al.	5,751,785 A	5/1998	Moorman et al.
5,546,949 A	8/1996	Frazin et al.	5,752,513 A	5/1998	Acker et al.
5,546,951 A	8/1996	Ben-Haim	5,758,650 A	6/1998	Miller et al.
5,555,618 A	9/1996	Winkler	5,762,064 A	6/1998	Polvani
5,558,091 A	9/1996	Acker et al.	5,767,669 A	6/1998	Hansen et al.
5,568,809 A	10/1996	Ben-haim	5,767,960 A	6/1998	Orman et al.
D375,450 S	11/1996	Bidwell et al.	5,769,786 A	6/1998	Wiegel
5,570,671 A	11/1996	Hickey	5,769,843 A	6/1998	Abela et al.
5,575,291 A	11/1996	Hayakawa et al.	5,769,881 A	6/1998	Schroepfel et al.
5,588,442 A	12/1996	Scovil et al.	5,771,896 A	6/1998	Sliwa, Jr. et al.
5,592,939 A	1/1997	Martinelli	5,775,322 A	7/1998	Silverstein et al.
5,598,846 A	2/1997	Peszynski	5,775,332 A	7/1998	Goldman
5,599,299 A	2/1997	Weaver et al.	5,776,064 A	7/1998	Kalfas et al.
5,600,330 A	2/1997	Blood	5,776,080 A	7/1998	Thome et al.
5,603,333 A	2/1997	Konings	5,779,638 A	7/1998	Vesely et al.
5,610,967 A	3/1997	Moorman et al.	5,782,767 A	7/1998	Pretlow, III
5,617,866 A	4/1997	Marian, Jr.	5,782,773 A *	7/1998	Kuo A61B 5/044 600/523
5,622,169 A	4/1997	Golden et al.	5,785,657 A	7/1998	Breyer et al.
5,622,170 A	4/1997	Schulz	5,792,055 A	8/1998	McKinnon et al.
5,622,184 A	4/1997	Ashby et al.	5,795,297 A	8/1998	Daigle
5,623,931 A	4/1997	Wung et al.	5,795,298 A	8/1998	Vesely et al.
5,624,430 A	4/1997	Eton et al.	5,795,632 A	8/1998	Buchalter
5,626,554 A	5/1997	Ryaby et al.	5,797,849 A	8/1998	Vesely et al.
5,626,870 A	5/1997	Monshipouri et al.	5,800,352 A	9/1998	Ferre et al.
5,630,419 A	5/1997	Ranalletta	5,800,410 A	9/1998	Gawreluk
5,638,819 A	6/1997	Manwaring et al.	5,800,497 A	9/1998	Bakels et al.
5,644,612 A	7/1997	Moorman et al.	5,803,089 A	9/1998	Ferre et al.
5,645,065 A	7/1997	Shapiro et al.	5,810,733 A	9/1998	Van Creveld et al.
5,651,047 A	7/1997	Moorman et al.	RE35,924 E	10/1998	Winkler
5,654,864 A	8/1997	Ritter et al.	5,817,022 A	10/1998	Vesely
D383,968 S	9/1997	Bidwell et al.	5,817,024 A	10/1998	Ogle et al.
5,662,115 A	9/1997	Torp et al.	5,820,549 A	10/1998	Marian, Jr.
5,665,103 A	9/1997	Lafontaine et al.	5,824,031 A	10/1998	Cookston et al.
5,665,477 A	9/1997	Meathrel et al.	5,827,192 A	10/1998	Gopakumaran et al.
5,666,473 A	9/1997	Wallace	5,829,444 A	11/1998	Ferre et al.
5,666,958 A	9/1997	Rothenberg et al.	5,830,145 A	11/1998	Tenhoff
5,669,383 A	9/1997	Johnson	5,831,260 A	11/1998	Hansen
5,669,388 A	9/1997	Vilkomerson	5,833,608 A	11/1998	Acker
5,676,159 A	10/1997	Navis	5,833,622 A	11/1998	Meathrel et al.
5,676,673 A	10/1997	Ferre et al.	5,835,561 A	11/1998	Moorman et al.
5,682,890 A	11/1997	Kormos et al.	5,836,882 A	11/1998	Frazin
5,691,898 A	11/1997	Rosenberg et al.	5,836,990 A	11/1998	Li
5,694,945 A	12/1997	Ben-Haim	5,840,024 A	11/1998	Taniguchi et al.
5,695,479 A	12/1997	Jaggpal	5,840,025 A	11/1998	Ben-Haim
5,697,377 A	12/1997	Wittkampf	5,840,030 A	11/1998	Ferek-Petric et al.
5,699,801 A	12/1997	Atalar et al.	5,840,031 A	11/1998	Crowley
5,700,889 A	12/1997	Blair	5,842,986 A	12/1998	Avrin et al.
5,701,898 A	12/1997	Adam et al.	5,842,998 A	12/1998	Gopakumaran et al.
5,702,433 A	12/1997	Taylor et al.	5,843,076 A	12/1998	Webster, Jr. et al.
5,711,299 A	1/1998	Manwaring et al.	5,843,153 A	12/1998	Johnston et al.
5,713,362 A	2/1998	Vilkomerson	5,844,140 A	12/1998	Seale
5,713,363 A	2/1998	Seward et al.	5,846,198 A	12/1998	Killmann
5,713,858 A	2/1998	Heruth et al.	5,855,553 A	1/1999	Tajima et al.
5,713,946 A	2/1998	Ben-Haim	5,859,893 A	1/1999	Moorman et al.
5,715,817 A	2/1998	Stevens-Wright et al.	5,865,748 A	2/1999	Co et al.
5,716,389 A	2/1998	Walinsky et al.	5,868,673 A	2/1999	Vesely
5,718,241 A	2/1998	Ben-Haim et al.	5,873,822 A	2/1999	Ferre et al.
D391,838 S	3/1998	Bidwell et al.	5,876,328 A	3/1999	Fox et al.
5,722,412 A	3/1998	Pflugrath et al.	5,879,297 A	3/1999	Haynor et al.
5,727,550 A	3/1998	Montecalvo	5,893,363 A	4/1999	Little et al.
5,727,552 A	3/1998	Ryan	5,897,495 A	4/1999	Aida et al.
5,727,553 A	3/1998	Saad	5,899,860 A	5/1999	Pfeiffer et al.
5,729,055 A	3/1998	Manning	5,902,238 A	5/1999	Golden et al.
5,729,129 A	3/1998	Acker	5,907,487 A	5/1999	Rosenberg et al.
5,729,584 A	3/1998	Moorman et al.	5,908,385 A	6/1999	Chechelski et al.
5,730,129 A	3/1998	Darrow et al.	5,910,113 A	6/1999	Pruter
5,731,996 A	3/1998	Gilbert	5,910,120 A	6/1999	Kim et al.
5,733,323 A	3/1998	Buck et al.	5,913,820 A	6/1999	Bladen et al.
5,738,096 A	4/1998	Ben-Haim	5,913,830 A	6/1999	Miles
5,740,808 A	4/1998	Panescu et al.	5,919,141 A	7/1999	Money et al.
5,742,394 A	4/1998	Hansen	5,919,170 A	7/1999	Woessner
5,744,953 A	4/1998	Hansen	5,928,145 A	7/1999	Ocali et al.
5,748,767 A	5/1998	Raab	5,929,607 A	7/1999	Rosenberg et al.
5,749,835 A	5/1998	Glantz	5,931,788 A	8/1999	Keen et al.
5,749,938 A	5/1998	Coombs	5,931,818 A	8/1999	Werp et al.
			5,931,863 A	8/1999	Griffin, III et al.
			5,941,858 A	8/1999	Johnson
			5,941,889 A	8/1999	Cermak

(56)

References Cited

U.S. PATENT DOCUMENTS

5,941,904 A	8/1999	Johnston et al.	6,167,765 B1	1/2001	Weitzel
5,944,022 A	8/1999	Nardella et al.	6,172,499 B1	1/2001	Ashe
5,944,023 A	8/1999	Johnson et al.	6,173,199 B1	1/2001	Gabriel
5,951,598 A	9/1999	Bishay et al.	6,173,715 B1	1/2001	Sinanan et al.
5,953,683 A	9/1999	Hansen et al.	6,175,756 B1	1/2001	Ferre et al.
5,957,857 A	9/1999	Hartley	6,176,829 B1	1/2001	Vilkomerson
5,961,923 A	10/1999	Nova et al.	6,187,744 B1	2/2001	Rooney
5,967,978 A	10/1999	Littmann et al.	6,190,370 B1	2/2001	Tsui
5,967,980 A	10/1999	Ferre et al.	6,191,136 B1	2/2001	Marban
5,967,991 A	10/1999	Gardineer et al.	6,193,743 B1	2/2001	Brayton et al.
5,969,722 A	10/1999	Palm	6,197,001 B1	3/2001	Wilson et al.
5,971,933 A	10/1999	Gopakumaran et al.	6,200,305 B1	3/2001	Berthiaume et al.
5,978,705 A	11/1999	KenKnight et al.	6,203,499 B1	3/2001	Imling et al.
5,983,126 A	11/1999	Wittkampf	6,208,884 B1	3/2001	Kumar et al.
5,984,908 A	11/1999	Davis et al.	6,211,626 B1	4/2001	Lys et al.
5,991,693 A	11/1999	Zalewski	6,211,666 B1	4/2001	Acker
5,997,473 A	12/1999	Taniguchi et al.	6,212,426 B1	4/2001	Swanson
5,997,481 A	12/1999	Adams et al.	6,216,027 B1	4/2001	Willis et al.
6,006,123 A	12/1999	Nguyen et al.	6,216,028 B1	4/2001	Haynor et al.
6,011,988 A	1/2000	Lynch et al.	6,216,029 B1	4/2001	Paltieli
6,014,473 A	1/2000	Hossack et al.	6,223,087 B1	4/2001	Williams
6,014,580 A	1/2000	Blume et al.	6,226,547 B1	5/2001	Lockhart et al.
6,015,414 A	1/2000	Werp et al.	6,230,042 B1	5/2001	Slettenmark
6,017,496 A	1/2000	Nova et al.	6,230,046 B1	5/2001	Crane et al.
6,019,724 A	2/2000	Gronningsaeter et al.	6,231,518 B1	5/2001	Grabek et al.
6,019,725 A	2/2000	Vesely et al.	6,233,476 B1	5/2001	Strommer et al.
6,022,342 A	2/2000	Mukherjee	6,233,994 B1	5/2001	Roy et al.
6,023,638 A	2/2000	Swanson	6,236,883 B1	5/2001	Ciaccio et al.
6,026,312 A	2/2000	Shemwell et al.	6,238,344 B1	5/2001	Gamelsky et al.
6,031,765 A	2/2000	Lee et al.	6,241,673 B1	6/2001	Williams
6,032,070 A	2/2000	Flock et al.	6,246,231 B1	6/2001	Ashe
6,039,694 A	3/2000	Larson et al.	6,246,898 B1	6/2001	Vesely et al.
6,050,718 A	4/2000	Schena et al.	6,248,072 B1	6/2001	Murkin
6,052,610 A	4/2000	Koch	6,248,074 B1	6/2001	Ohno et al.
6,052,618 A	4/2000	Dahlke et al.	6,248,075 B1	6/2001	McGee et al.
D424,693 S	5/2000	Pruter	6,253,770 B1	7/2001	Acker et al.
6,059,718 A	5/2000	Taniguchi et al.	6,258,035 B1	7/2001	Hoeksel et al.
6,064,905 A	5/2000	Webster, Jr. et al.	6,259,941 B1	7/2001	Chia et al.
6,066,094 A	5/2000	Ben-Haim	6,261,231 B1	7/2001	Damphousse et al.
6,068,599 A	5/2000	Saito et al.	6,263,230 B1	7/2001	Haynor et al.
6,073,043 A	6/2000	Schneider	6,266,550 B1	7/2001	Selmon et al.
6,074,367 A	6/2000	Hubbell	6,266,551 B1	7/2001	Osadchy et al.
6,075,442 A	6/2000	Welch	6,266,552 B1	7/2001	Slettenmark
6,076,007 A	6/2000	England et al.	6,266,563 B1	7/2001	KenKnight et al.
6,081,737 A	6/2000	Shah	6,270,493 B1	8/2001	Lalonde et al.
6,082,366 A	7/2000	Andra et al.	6,271,833 B1	8/2001	Rosenberg et al.
6,083,170 A	7/2000	Ben-Haim	6,272,371 B1	8/2001	Shlomo
6,099,524 A	8/2000	Lipsin et al.	6,272,374 B1	8/2001	Flock et al.
6,100,026 A	8/2000	Nova et al.	6,275,258 B1	8/2001	Chim
6,102,044 A	8/2000	Naidyhorski	6,275,724 B1	8/2001	Dickinson et al.
6,107,699 A	8/2000	Swanson	6,277,077 B1	8/2001	Brisken et al.
6,112,111 A	8/2000	Glantz	6,284,459 B1	9/2001	Nova et al.
6,112,115 A	8/2000	Feldman et al.	6,285,898 B1	9/2001	Ben-Haim
6,113,504 A	9/2000	Kuesters	6,287,260 B1	9/2001	Hascoet et al.
6,115,624 A	9/2000	Lewis et al.	6,288,704 B1	9/2001	Flack et al.
6,120,445 A	9/2000	Grunwald	6,292,678 B1	9/2001	Hall et al.
6,122,538 A	9/2000	Sliwa, Jr. et al.	6,292,680 B1	9/2001	Somogyi et al.
6,128,174 A	10/2000	Ritter et al.	6,292,901 B1	9/2001	Lys et al.
6,129,668 A	10/2000	Haynor et al.	6,293,955 B1	9/2001	Houser et al.
6,132,378 A	10/2000	Marino	6,296,604 B1	10/2001	Garibaldi et al.
6,132,379 A	10/2000	Patacsil et al.	6,298,261 B1	10/2001	Rex
6,135,961 A	10/2000	Pflugrath et al.	6,304,768 B1	10/2001	Blume et al.
6,136,274 A	10/2000	Nova et al.	6,306,097 B1	10/2001	Park et al.
6,138,681 A	10/2000	Chen et al.	6,306,105 B1	10/2001	Rooney et al.
6,139,496 A	10/2000	Chen et al.	6,311,082 B1	10/2001	Creighton, IV et al.
6,139,502 A	10/2000	Fredriksen	6,315,709 B1	11/2001	Garibaldi et al.
6,139,540 A	10/2000	Rost et al.	6,315,727 B1	11/2001	Coleman et al.
6,144,300 A	11/2000	Dames et al.	6,319,668 B1	11/2001	Nova et al.
6,148,823 A	11/2000	Hastings	6,323,769 B1	11/2001	Dames et al.
6,152,933 A	11/2000	Werp et al.	6,323,770 B1	11/2001	Dames et al.
6,157,853 A	12/2000	Blume et al.	6,324,416 B1	11/2001	Seibert
6,165,144 A	12/2000	Talish et al.	6,325,540 B1	12/2001	Lounsbury et al.
6,165,977 A	12/2000	Mochly-Rosen	6,325,762 B1	12/2001	Tjin
6,166,496 A	12/2000	Lys et al.	6,329,139 B1	12/2001	Nova et al.
6,166,806 A	12/2000	Tjin	6,329,916 B1	12/2001	Dames et al.
			6,330,467 B1	12/2001	Creighton, IV et al.
			6,332,089 B1	12/2001	Acker et al.
			6,332,874 B1	12/2001	Eliassen et al.
			6,340,588 B1	1/2002	Nova et al.

(56)

References Cited

U.S. PATENT DOCUMENTS

6,340,868	B1	1/2002	Lys et al.	6,514,249	B1	2/2003	Maguire et al.
6,341,231	B1	1/2002	Ferre et al.	6,515,657	B1	2/2003	Zanelli
6,346,081	B1	2/2002	Vilkomerson	6,516,212	B1	2/2003	Bladen et al.
6,348,911	B1	2/2002	Rosenberg et al.	6,516,231	B1	2/2003	Flammang
6,350,160	B1	2/2002	Feuersanger et al.	6,516,807	B1	2/2003	Panescu et al.
6,352,363	B1	3/2002	Munger et al.	6,517,520	B2	2/2003	Chang et al.
6,354,999	B1	3/2002	Dgany et al.	6,522,906	B1	2/2003	Salisbury, Jr. et al.
6,355,026	B1	3/2002	Mick	6,522,907	B1	2/2003	Bladen et al.
6,356,791	B1	3/2002	Westlund et al.	6,522,909	B1	2/2003	Garibaldi et al.
6,360,123	B1	3/2002	Kimchi et al.	6,524,303	B1	2/2003	Garibaldi
6,361,499	B1	3/2002	Bates et al.	6,528,954	B1	3/2003	Lys et al.
6,364,823	B1	4/2002	Garibaldi et al.	6,528,991	B2	3/2003	Ashe
6,364,839	B1	4/2002	Little et al.	6,529,761	B2	3/2003	Creighton, IV et al.
6,366,804	B1	4/2002	Mejia	6,529,766	B1	3/2003	Guendel
6,368,285	B1	4/2002	Osadchy et al.	6,534,982	B1	3/2003	Jakab
6,370,411	B1	4/2002	Osadchy et al.	6,535,625	B1	3/2003	Chang et al.
6,373,240	B1	4/2002	Govari	6,537,192	B1	3/2003	Elliott et al.
6,373,388	B1	4/2002	Dames et al.	6,537,196	B1	3/2003	Creighton, IV et al.
6,374,134	B1	4/2002	Bladen et al.	6,538,634	B1	3/2003	Chui et al.
6,374,670	B1	4/2002	Spelman et al.	6,540,699	B1	4/2003	Smith et al.
6,375,606	B1	4/2002	Garibaldi et al.	6,542,766	B2	4/2003	Hall et al.
6,375,639	B1	4/2002	Duplessie et al.	6,544,251	B1	4/2003	Crawford
6,377,857	B1	4/2002	Brayton et al.	6,545,678	B1	4/2003	Ohazama
6,379,302	B1	4/2002	Kessman et al.	6,546,270	B1	4/2003	Goldin et al.
6,379,303	B1	4/2002	Seitz et al.	6,546,279	B1	4/2003	Bova et al.
6,379,307	B1	4/2002	Filly et al.	6,546,787	B1	4/2003	Schiller et al.
6,381,485	B1	4/2002	Hunter et al.	6,552,841	B1	4/2003	Lasser et al.
6,385,472	B1	5/2002	Hall et al.	6,556,858	B1	4/2003	Zeman
6,385,476	B1	5/2002	Osadchy et al.	6,562,019	B1	5/2003	Sell
6,398,736	B1	6/2002	Seward	6,564,087	B1	5/2003	Pitris et al.
6,398,738	B1	6/2002	Millar	6,569,101	B2	5/2003	Quistgaard et al.
6,401,723	B1	6/2002	Garibaldi et al.	6,569,103	B2	5/2003	Hoeksel et al.
6,406,422	B1	6/2002	Landesberg	6,569,160	B1	5/2003	Goldin et al.
6,406,442	B1	6/2002	McFann et al.	6,569,862	B1	5/2003	Marban
6,412,978	B1	7/2002	Watanabe et al.	6,571,004	B1	5/2003	Florent et al.
6,412,980	B1	7/2002	Lounsberry et al.	6,574,518	B1	6/2003	Lounsberry et al.
6,417,839	B1	7/2002	Odell	6,575,908	B2	6/2003	Barnes et al.
6,418,332	B1	7/2002	Mastrototaro et al.	6,577,080	B2	6/2003	Lys et al.
6,418,335	B2	7/2002	Avrin et al.	6,577,896	B2	6/2003	Werner et al.
6,423,002	B1	7/2002	Hossack	6,584,343	B1	6/2003	Ransbury et al.
6,423,050	B1	7/2002	Twardowski	6,593,754	B1	7/2003	Steber et al.
6,427,079	B1	7/2002	Schneider et al.	6,593,884	B1	7/2003	Gilboa et al.
6,428,551	B1	8/2002	Hall et al.	6,597,943	B2	7/2003	Taha et al.
6,430,315	B1	8/2002	Makram-Ebeid	6,599,249	B1	7/2003	Nordgren et al.
6,432,069	B1	8/2002	Godo et al.	6,607,488	B1	8/2003	Jackson et al.
6,438,411	B1	8/2002	Guttman et al.	6,610,058	B2	8/2003	Flores
6,442,416	B1	8/2002	Schultz	6,611,141	B1	8/2003	Schulz et al.
6,445,943	B1	9/2002	Ferre et al.	6,615,071	B1	9/2003	Casscells, III et al.
6,456,874	B1	9/2002	Hafer et al.	6,615,155	B2	9/2003	Gilboa
6,459,919	B1	10/2002	Lys et al.	6,616,610	B2	9/2003	Steininger et al.
6,463,121	B1	10/2002	Milnes	6,618,612	B1	9/2003	Acker et al.
6,466,815	B1	10/2002	Saito et al.	6,626,832	B1	9/2003	Paltieli et al.
6,471,656	B1	10/2002	Shalman et al.	6,626,834	B2	9/2003	Dunne et al.
6,471,658	B1	10/2002	Daniels et al.	6,626,902	B1	9/2003	Kucharczyk et al.
6,471,700	B1	10/2002	Burbank et al.	6,630,879	B1	10/2003	Creighton, IV et al.
6,473,167	B1	10/2002	Odell	6,635,027	B1	10/2003	Cragg et al.
6,474,341	B1	11/2002	Hunter et al.	6,645,148	B2	11/2003	Nguyen-Dinh et al.
6,475,152	B1	11/2002	Kelly, Jr. et al.	6,648,875	B2	11/2003	Simpson et al.
6,475,223	B1	11/2002	Werp et al.	6,649,914	B1	11/2003	Moorman et al.
6,477,402	B1	11/2002	Lynch et al.	6,652,505	B1	11/2003	Tsugita
6,484,118	B1	11/2002	Govari et al.	6,652,506	B2	11/2003	Bowe et al.
6,487,916	B1	12/2002	Gomm et al.	6,660,024	B1	12/2003	Flaherty et al.
6,491,671	B1	12/2002	Larson, III et al.	6,662,034	B2	12/2003	Segner et al.
6,493,573	B1	12/2002	Martinelli et al.	6,663,661	B2	12/2003	Boneau
6,494,832	B1	12/2002	Feldman et al.	6,666,828	B2	12/2003	Greco et al.
6,496,715	B1	12/2002	Lee et al.	6,672,308	B1	1/2004	Gaspari
6,498,944	B1	12/2002	Ben-Haim et al.	6,677,752	B1	1/2004	Creighton, IV et al.
6,500,141	B1	12/2002	Irion et al.	6,679,857	B1	1/2004	Bastia et al.
6,505,062	B1	1/2003	Ritter et al.	6,684,176	B2	1/2004	Willins et al.
6,506,159	B2	1/2003	Hascoet et al.	6,685,644	B2	2/2004	Seo
6,507,751	B2	1/2003	Blume et al.	6,687,531	B1	2/2004	Ferre et al.
6,508,802	B1	1/2003	Rosengart et al.	6,689,119	B1	2/2004	Di Caprio et al.
6,511,413	B2	1/2003	Landesberg	6,690,963	B2	2/2004	Ben-Haim et al.
6,512,958	B1	1/2003	Swoyer et al.	6,690,964	B2	2/2004	Bieger et al.
6,514,226	B1	2/2003	Levin et al.	6,690,968	B2	2/2004	Mejia
				6,694,167	B1	2/2004	Ferre et al.
				6,695,786	B2	2/2004	Wang et al.
				6,701,179	B1	3/2004	Martinelli et al.
				6,701,918	B2	3/2004	Fariss et al.

(56)

References Cited

U.S. PATENT DOCUMENTS

6,702,804	B1	3/2004	Ritter et al.	6,999,821	B2	2/2006	Jenney et al.
6,704,590	B2	3/2004	Haldeman	7,001,355	B2	2/2006	Nunomura et al.
6,709,390	B1	3/2004	Marie Pop	7,008,418	B2	3/2006	Hall et al.
6,711,429	B1	3/2004	Gilboa et al.	7,010,338	B2	3/2006	Ritter et al.
6,711,431	B2	3/2004	Sarin et al.	7,015,393	B2	3/2006	Weiner et al.
6,719,699	B2	4/2004	Smith	7,017,584	B2	3/2006	Garibaldi et al.
6,719,724	B1	4/2004	Walker et al.	7,019,610	B2	3/2006	Creighton, IV et al.
6,719,756	B1	4/2004	Muntermann	7,020,512	B2	3/2006	Ritter et al.
6,720,745	B2	4/2004	Lys et al.	D518,574	S	4/2006	Chaggares
6,733,458	B1	5/2004	Steins et al.	7,022,075	B2	4/2006	Grunwald et al.
6,733,511	B2	5/2004	Hall et al.	7,022,082	B2	4/2006	Sonek
6,736,782	B2	5/2004	Pfeiffer et al.	7,026,927	B2	4/2006	Wright et al.
6,738,656	B1	5/2004	Ferre et al.	7,027,634	B2	4/2006	Odell
6,740,103	B2	5/2004	Hall et al.	7,028,387	B1	4/2006	Huynh et al.
6,743,177	B2	6/2004	Ito et al.	7,029,446	B2	4/2006	Wendelken et al.
6,754,596	B2	6/2004	Ashe	7,033,603	B2	4/2006	Nelson et al.
6,755,789	B2	6/2004	Stringer et al.	D520,139	S	5/2006	Chaggares
6,755,816	B2	6/2004	Ritter et al.	D520,140	S	5/2006	Chaggares
6,755,822	B2	6/2004	Reu et al.	7,038,398	B1	5/2006	Lys et al.
6,757,557	B1	6/2004	Bladen et al.	7,038,657	B2	5/2006	Rosenberg et al.
6,763,261	B2	7/2004	Casscells, III et al.	7,043,293	B1	5/2006	Baura
6,764,449	B2	7/2004	Lee et al.	7,048,733	B2	5/2006	Hartley et al.
6,768,496	B2	7/2004	Bieger et al.	7,054,228	B1	5/2006	Hickling
6,772,001	B2	8/2004	Maschke et al.	7,065,403	B1	6/2006	Mouchawar et al.
6,774,624	B2	8/2004	Anderson et al.	7,066,914	B2	6/2006	Andersen
6,783,536	B2	8/2004	Vilsmeier et al.	7,066,924	B1	6/2006	Garibaldi et al.
6,784,660	B2	8/2004	Ashe	7,069,072	B2	6/2006	Jansen et al.
6,785,571	B2	8/2004	Glossop et al.	D525,363	S	7/2006	Chaggares
6,786,219	B2	9/2004	Garibaldi et al.	7,070,565	B2	7/2006	Vaezy et al.
6,786,870	B2	9/2004	Miyaki et al.	7,072,704	B2	7/2006	Bucholz
6,788,967	B2	9/2004	Ben-Haim et al.	7,082,325	B2	7/2006	Hashimshony et al.
6,794,667	B2	9/2004	Noshi	7,090,639	B2	8/2006	Govari
6,799,066	B2	9/2004	Steines et al.	7,096,059	B2	8/2006	Geddes et al.
6,815,651	B2	11/2004	Odell	7,096,148	B2	8/2006	Anderson et al.
6,816,266	B2	11/2004	Varshneya et al.	7,096,870	B2	8/2006	Lamprich et al.
6,817,364	B2	11/2004	Garibaldi	7,098,907	B2	8/2006	Houston et al.
6,834,201	B2	12/2004	Gillies et al.	7,103,205	B2	9/2006	Wang et al.
6,844,713	B2	1/2005	Steber et al.	7,104,980	B1	9/2006	Laherty et al.
6,845,142	B2	1/2005	Ohishi	7,106,043	B1	9/2006	Da Silva et al.
6,856,823	B2	2/2005	Ashe	7,106,431	B2	9/2006	Odell
6,860,422	B2	3/2005	Hull et al.	7,106,479	B2	9/2006	Roy et al.
6,862,467	B2	3/2005	Moore et al.	7,107,105	B2	9/2006	Bjorklund et al.
6,869,390	B2	3/2005	Elliott et al.	7,112,197	B2	9/2006	Hartley et al.
6,875,179	B2	4/2005	Ferguson et al.	7,128,734	B1	10/2006	Wilson et al.
6,879,160	B2	4/2005	Jakab	7,132,804	B2	11/2006	Lys et al.
6,887,206	B2	5/2005	Hoeksel et al.	7,137,976	B2	11/2006	Ritter et al.
6,889,091	B2	5/2005	Hine et al.	7,141,019	B2	11/2006	Pearlman
6,895,268	B1	5/2005	Rahn et al.	7,141,812	B2	11/2006	Appleby et al.
6,902,528	B1	6/2005	Garibaldi et al.	7,142,905	B2	11/2006	Slayton et al.
6,905,469	B2	6/2005	Hascoet et al.	7,148,970	B2	12/2006	de Boer
6,908,433	B1	6/2005	Pruter	7,153,291	B2	12/2006	Bierman
6,911,026	B1	6/2005	Hall et al.	7,161,453	B2	1/2007	Creighton, IV
6,923,782	B2	8/2005	O'Mahony et al.	7,162,291	B1	1/2007	Nachaliel
6,926,673	B2	8/2005	Roberts et al.	7,167,738	B2	1/2007	Schweikard et al.
6,926,674	B2	8/2005	Tenerz et al.	7,169,107	B2	1/2007	Jersey-Willuhn et al.
6,934,575	B2	8/2005	Ferre et al.	7,169,109	B2	1/2007	Jansen et al.
6,936,010	B2	8/2005	Fang et al.	7,174,201	B2	2/2007	Govari et al.
6,939,313	B2	9/2005	Saadat et al.	7,175,646	B2	2/2007	Brenneman et al.
6,940,379	B2	9/2005	Creighton	7,180,252	B2	2/2007	Lys et al.
6,941,166	B2	9/2005	MacAdam et al.	7,184,820	B2	2/2007	Jersey-Willuhn et al.
6,947,788	B2	9/2005	Gilboa et al.	7,189,198	B2	3/2007	Harburn et al.
6,950,689	B1	9/2005	Willis et al.	7,189,205	B2	3/2007	McMorrow et al.
6,953,754	B2	10/2005	Machida et al.	7,189,208	B1	3/2007	Beatty et al.
6,958,677	B1	10/2005	Carter	7,190,819	B2	3/2007	Viswanathan
6,959,214	B2	10/2005	Pape et al.	7,194,295	B2	3/2007	Vilsmeier
6,962,566	B2	11/2005	Quistgaard et al.	7,204,798	B2	4/2007	Zdeblick et al.
6,968,846	B2	11/2005	Viswanathan	7,206,064	B2	4/2007	Rogers et al.
6,975,197	B2	12/2005	Creighton, IV	7,207,941	B2	4/2007	Sharf
6,976,962	B2	12/2005	Bullis	7,211,082	B2	5/2007	Hall et al.
6,976,987	B2	12/2005	Flores	7,214,191	B2	5/2007	Stringer et al.
6,980,843	B2	12/2005	Eng et al.	7,215,326	B2	5/2007	Rosenberg
6,980,852	B2	12/2005	Jersey-Willuhn et al.	7,221,104	B2	5/2007	Lys et al.
6,980,921	B2	12/2005	Anderson et al.	7,223,256	B2	5/2007	Bierman
6,986,739	B2	1/2006	Warren et al.	7,229,400	B2	6/2007	Elliott et al.
6,986,744	B1	1/2006	Krivitski	7,231,243	B2	6/2007	Tearney et al.
				7,236,157	B2	6/2007	Schena et al.
				7,236,816	B2	6/2007	Kumar et al.
				7,236,820	B2	6/2007	Mabary et al.
				7,237,313	B2	7/2007	Skujins et al.

(56)

References Cited

U.S. PATENT DOCUMENTS

7,241,267 B2	7/2007	Furia	7,833,168 B2	11/2010	Taylor et al.
7,244,234 B2	7/2007	Ridley et al.	7,833,214 B2	11/2010	Wilson et al.
7,248,032 B1	7/2007	Hular et al.	D629,526 S	12/2010	Ladwig et al.
7,248,914 B2	7/2007	Hastings et al.	D629,527 S	12/2010	Crunkilton
7,252,633 B2	8/2007	Obata et al.	7,846,157 B2	12/2010	Kozel
7,264,584 B2	9/2007	Ritter et al.	7,850,613 B2	12/2010	Stribling
7,270,662 B2	9/2007	Visram et al.	D630,756 S	1/2011	Kitayama
7,276,044 B2	10/2007	Ferry et al.	D630,757 S	1/2011	Kitayama
7,286,034 B2	10/2007	Creighton	7,869,854 B2	1/2011	Shachar et al.
7,291,146 B2	11/2007	Steinke et al.	7,873,402 B2	1/2011	Shachar
7,297,140 B2	11/2007	Orlu et al.	7,909,815 B2	3/2011	Whitmore, III et al.
7,300,430 B2	11/2007	Wilson et al.	7,931,596 B2	4/2011	Rachlin et al.
7,302,288 B1	11/2007	Schellenberg	7,947,040 B2	5/2011	Davies et al.
7,308,296 B2	12/2007	Lys et al.	7,976,469 B2	7/2011	Bonde et al.
7,310,150 B2	12/2007	Guillermo et al.	7,976,518 B2	7/2011	Shaughnessy et al.
7,311,702 B2	12/2007	Tallarida et al.	7,981,038 B2	7/2011	Kanade et al.
7,321,228 B2	1/2008	Govari	7,988,633 B2	8/2011	Hossack et al.
7,326,241 B2	2/2008	Jang	8,016,814 B2	9/2011	Blakstvedt et al.
7,327,872 B2	2/2008	Vaillant et al.	8,046,052 B2	10/2011	Verard et al.
7,342,058 B2	3/2008	Peppmoller et al.	8,057,394 B2	11/2011	Dala-Krishna
7,349,732 B1*	3/2008	Kil A61B 5/042 600/510	8,060,185 B2	11/2011	Hunter et al.
7,355,716 B2	4/2008	de Boer et al.	8,078,274 B2	12/2011	Kassab
7,360,427 B2	4/2008	Drinkwater et al.	8,078,279 B2	12/2011	Dennis et al.
7,366,376 B2	4/2008	Shishkov et al.	8,082,032 B2	12/2011	Kassab et al.
7,366,562 B2	4/2008	Dukesherer et al.	8,088,072 B2	1/2012	Munrow et al.
7,366,563 B2	4/2008	Kleen et al.	8,090,430 B2	1/2012	Makower et al.
7,373,271 B1	5/2008	Schneider	8,099,161 B2	1/2012	Kassab
7,381,204 B2	6/2008	Wilson et al.	8,114,143 B2	2/2012	Kassab et al.
7,382,949 B2	6/2008	Bouma et al.	8,118,743 B2	2/2012	Park et al.
7,384,407 B2	6/2008	Rodriguez et al.	8,123,691 B2	2/2012	Mine et al.
7,418,169 B2	8/2008	Tearney et al.	8,133,698 B2	3/2012	Silver
7,447,408 B2	11/2008	Bouma et al.	8,142,417 B2	3/2012	Pajunk et al.
7,452,331 B1	11/2008	Pruter	8,150,522 B2	4/2012	Echaz et al.
7,452,358 B2	11/2008	Stern et al.	8,152,724 B2	4/2012	Ridley et al.
7,454,244 B2	11/2008	Kassab et al.	8,204,582 B2	6/2012	Zantos et al.
D585,556 S	1/2009	Kosaku	8,214,018 B2	7/2012	Markowitz et al.
7,479,141 B2	1/2009	Kleen et al.	8,221,402 B2	7/2012	Francischelli et al.
7,519,424 B2	4/2009	Dennis et al.	8,240,211 B2	8/2012	Zeitner et al.
7,529,584 B2	5/2009	Laske et al.	8,241,274 B2	8/2012	Keogh et al.
7,534,223 B2	5/2009	Boutillette et al.	8,244,339 B2	8/2012	Shen et al.
7,538,859 B2	5/2009	Tearney et al.	8,255,035 B2	8/2012	Cao et al.
7,543,239 B2	6/2009	Viswanathan et al.	8,260,395 B2	9/2012	Markowitz et al.
7,546,158 B2	6/2009	Allison et al.	8,262,577 B2	9/2012	Munrow et al.
7,547,282 B2	6/2009	Lo et al.	8,298,149 B2	10/2012	Hastings et al.
7,551,293 B2	6/2009	Yelin et al.	8,303,502 B2	11/2012	Washburn et al.
D603,050 S	10/2009	Chen	8,303,505 B2	11/2012	Webler et al.
7,599,730 B2	10/2009	Hunter et al.	8,326,419 B2	12/2012	Rosenberg et al.
7,606,615 B2	10/2009	Makower et al.	8,340,751 B2	12/2012	Markowitz et al.
7,616,992 B2	11/2009	Dennis et al.	8,369,922 B2	2/2013	Paul et al.
7,627,376 B2	12/2009	Dennis et al.	8,388,541 B2	3/2013	Messerly et al.
7,635,336 B1	12/2009	Pruter	8,388,546 B2	3/2013	Rothenberg
7,637,163 B2	12/2009	Fetzer et al.	8,391,956 B2	3/2013	Zellers et al.
7,640,053 B2	12/2009	Verin	8,401,616 B2	3/2013	Verard et al.
7,651,469 B2	1/2010	Osborne et al.	8,409,103 B2	4/2013	Grunwald et al.
7,652,080 B2	1/2010	Peppmoller et al.	8,425,425 B2	4/2013	Hagy et al.
7,660,623 B2	2/2010	Hunter et al.	8,437,833 B2	5/2013	Silverstein
7,665,893 B2	2/2010	Buchalter	8,439,873 B1	5/2013	Donovan
7,668,583 B2	2/2010	Fegert et al.	8,442,621 B2	5/2013	Gorek et al.
7,697,972 B2	4/2010	Verard et al.	8,447,384 B2	5/2013	Xu et al.
7,699,782 B2	4/2010	Angelsen et al.	D684,265 S	6/2013	Cadera
7,699,829 B2	4/2010	Harris et al.	8,456,182 B2	6/2013	Bar-Tal et al.
7,715,925 B2	5/2010	Hafer et al.	8,478,382 B2	7/2013	Burnside et al.
7,727,192 B2	6/2010	Tokumoto et al.	8,485,980 B2	7/2013	Sinderby et al.
7,729,743 B2	6/2010	Sabczynski et al.	8,494,608 B2	7/2013	Markowitz et al.
7,751,865 B2	7/2010	Jascob et al.	8,496,592 B2	7/2013	Ridley et al.
7,766,839 B2	8/2010	Rogers et al.	8,504,139 B2	8/2013	Jacobsen et al.
7,771,437 B2	8/2010	Hogg et al.	8,512,256 B2	8/2013	Rothenberg
7,774,051 B2	8/2010	Voth	8,527,036 B2	9/2013	Jalde et al.
7,774,055 B1	8/2010	Min	8,538,509 B2	9/2013	Harlev et al.
7,794,407 B2	9/2010	Rothenberg	8,644,907 B2	2/2014	Hartmann et al.
7,798,970 B2	9/2010	Lo et al.	8,734,440 B2	5/2014	Wu
7,819,810 B2	10/2010	Stringer et al.	8,774,907 B2	7/2014	Rothenberg
7,828,528 B2	11/2010	Estes et al.	8,781,555 B2	7/2014	Burnside et al.
7,831,294 B2	11/2010	Viswanathan	8,784,336 B2	7/2014	Bown et al.
			8,801,693 B2	8/2014	He et al.
			8,849,382 B2	9/2014	Cox et al.
			8,858,455 B2	10/2014	Rothenberg
			8,934,961 B2	1/2015	Lakin et al.
			8,971,994 B2	3/2015	Burnside et al.

(56)

References Cited

U.S. PATENT DOCUMENTS

9,125,578	B2	9/2015	Grunwald	2004/0116809	A1	6/2004	Chow et al.
9,339,206	B2	5/2016	Grunwald	2004/0127805	A1	7/2004	MacAdam et al.
9,456,766	B2	10/2016	Cox et al.	2004/0131998	A1	7/2004	Marom et al.
9,492,097	B2	11/2016	Wilkes et al.	2004/0133111	A1	7/2004	Szcezech et al.
2002/0010392	A1	1/2002	Desai	2004/0133130	A1	7/2004	Ferry et al.
2002/0019447	A1	2/2002	Renn et al.	2004/0135069	A1	7/2004	Odell
2002/0022777	A1	2/2002	Crieghton et al.	2004/0138557	A1	7/2004	Le et al.
2002/0032391	A1	3/2002	McFann et al.	2004/0138564	A1	7/2004	Hwang et al.
2002/0049488	A1	4/2002	Boneau	2004/0138570	A1	7/2004	Nita et al.
2002/0055680	A1	5/2002	Miele et al.	2004/0147837	A1	7/2004	Macaulay et al.
2002/0082559	A1	6/2002	Chang et al.	2004/0150963	A1	8/2004	Holmberg et al.
2002/0113555	A1	8/2002	Lys et al.	2004/0152972	A1	8/2004	Hunter
2002/0123679	A1	9/2002	Dominguez	2004/0155609	A1	8/2004	Lys et al.
2002/0128554	A1	9/2002	Seward	2004/0158140	A1	8/2004	Fuimaono et al.
2002/0129952	A1	9/2002	Matsudate et al.	2004/0171924	A1	9/2004	Mire et al.
2002/0133079	A1	9/2002	Sandhu	2004/0176688	A1	9/2004	Haldeman
2002/0156363	A1	10/2002	Hunter et al.	2004/0186461	A1	9/2004	DiMatteo
2002/0156376	A1	10/2002	Wang et al.	2004/0199069	A1	10/2004	Connelly et al.
2002/0165448	A1	11/2002	Ben-Haim et al.	2004/0210289	A1	10/2004	Wang et al.
2002/0165534	A1	11/2002	Hayzelden et al.	2004/0225233	A1	11/2004	Frankowski et al.
2002/0165537	A1	11/2002	Kelley et al.	2004/0230131	A1	11/2004	Kassab et al.
2002/0198568	A1	12/2002	Hafer et al.	2004/0230271	A1	11/2004	Wang et al.
2003/0009132	A1	1/2003	Schwartz et al.	2004/0234453	A1	11/2004	Smith
2003/0011359	A1	1/2003	Ashe	2004/0243018	A1	12/2004	Organ et al.
2003/0013966	A1	1/2003	Barnes et al.	2004/0243116	A1	12/2004	Joye et al.
2003/0013986	A1	1/2003	Saadat	2004/0243118	A1	12/2004	Ayers et al.
2003/0036696	A1	2/2003	Willis et al.	2004/0253365	A1	12/2004	Warren et al.
2003/0040671	A1	2/2003	Somogyi et al.	2004/0254470	A1	12/2004	Drinkwater et al.
2003/0040743	A1	2/2003	Cosman et al.	2004/0254495	A1	12/2004	Mabary et al.
2003/0072805	A1	4/2003	Miyazawa et al.	2004/0260174	A1	12/2004	Keene
2003/0073901	A1	4/2003	Simon et al.	2004/0267086	A1	12/2004	Anstadt et al.
2003/0076281	A1	4/2003	Morgan et al.	2005/0004450	A1	1/2005	Ben-Haim et al.
2003/0083698	A1	5/2003	Whitehurst et al.	2005/0021019	A1	1/2005	Hashimshony et al.
2003/0088195	A1	5/2003	Vardi et al.	2005/0033150	A1	2/2005	Takahashi et al.
2003/0100849	A1	5/2003	Jang	2005/0038355	A1	2/2005	Gellman et al.
2003/0114742	A1	6/2003	Lewkowicz et al.	2005/0043640	A1	2/2005	Chang
2003/0114777	A1	6/2003	Griffin et al.	2005/0049486	A1	3/2005	Urquhart et al.
2003/0120150	A1	6/2003	Govari	2005/0049510	A1	3/2005	Haldeman et al.
2003/0120154	A1	6/2003	Sauer et al.	2005/0063194	A1	3/2005	Lys et al.
2003/0139661	A1	7/2003	Kimchy et al.	2005/0070788	A1	3/2005	Wilson et al.
2003/0149328	A1	8/2003	Elliott et al.	2005/0075561	A1	4/2005	Golden
2003/0149368	A1	8/2003	Hennemann et al.	2005/0085716	A1	4/2005	Hamm et al.
2003/0152290	A1	8/2003	Odell	2005/0085718	A1	4/2005	Shahidi
2003/0160721	A1	8/2003	Gilboa et al.	2005/0085720	A1	4/2005	Jascob et al.
2003/0163037	A1	8/2003	Bladen et al.	2005/0090746	A1	4/2005	Ohtake
2003/0163142	A1	8/2003	Paltieli et al.	2005/0101868	A1	5/2005	Ridley et al.
2003/0171691	A1	9/2003	Casscells et al.	2005/0101869	A1	5/2005	Burba et al.
2003/0173953	A1	9/2003	Ashe	2005/0105081	A1	5/2005	Odell
2003/0181892	A1	9/2003	Pajunk et al.	2005/0105101	A1	5/2005	Duling et al.
2003/0184544	A1	10/2003	Prudent	2005/0112135	A1	5/2005	Cormier et al.
2003/0191392	A1	10/2003	Haldeman	2005/0113669	A1	5/2005	Helfer et al.
2003/0191460	A1	10/2003	Hobbs et al.	2005/0113676	A1	5/2005	Weiner et al.
2003/0195420	A1	10/2003	Mendlein et al.	2005/0113700	A1	5/2005	Yanagihara et al.
2003/0199746	A1	10/2003	Fuimaono et al.	2005/0113873	A1	5/2005	Weiner et al.
2003/0208142	A1	11/2003	Boudewijn et al.	2005/0113874	A1	5/2005	Connelly et al.
2003/0216639	A1	11/2003	Gilboa et al.	2005/0113876	A1	5/2005	Weiner et al.
2003/0220557	A1	11/2003	Cleary et al.	2005/0148836	A1	7/2005	Kleen et al.
2003/0220578	A1	11/2003	Ho et al.	2005/0148902	A1	7/2005	Minar et al.
2003/0229298	A1	12/2003	Iwami et al.	2005/0149002	A1	7/2005	Wang et al.
2003/0233042	A1	12/2003	Ashe	2005/0151489	A1	7/2005	Lys et al.
2003/0236445	A1	12/2003	Couvillon	2005/0154308	A1	7/2005	Quistgaard et al.
2004/0010189	A1	1/2004	van Sloun et al.	2005/0159644	A1	7/2005	Takano
2004/0015070	A1	1/2004	Liang et al.	2005/0159790	A1	7/2005	Shalev
2004/0024301	A1	2/2004	Hockett et al.	2005/0165301	A1	7/2005	Smith et al.
2004/0030319	A1	2/2004	Korkor et al.	2005/0165313	A1	7/2005	Byron et al.
2004/0054278	A1	3/2004	Kimchy et al.	2005/0175665	A1	8/2005	Hunter et al.
2004/0059237	A1	3/2004	Narayan et al.	2005/0175703	A1	8/2005	Hunter et al.
2004/0082916	A1	4/2004	Jenkins	2005/0178395	A1	8/2005	Hunter et al.
2004/0087877	A1	5/2004	Besz et al.	2005/0178396	A1	8/2005	Hunter et al.
2004/0088136	A1	5/2004	Ashe	2005/0182295	A1	8/2005	Soper et al.
2004/0092962	A1	5/2004	Thornton et al.	2005/0197674	A1	9/2005	McCabe et al.
2004/0097803	A1	5/2004	Panescu	2005/0203368	A1	9/2005	Verin
2004/0097804	A1	5/2004	Sobe	2005/0203396	A1	9/2005	Angelsen et al.
2004/0097805	A1	5/2004	Verard et al.	2005/0205081	A1	9/2005	Barker et al.
2004/0097806	A1	5/2004	Hunter et al.	2005/0215901	A1	9/2005	Anderson et al.
				2005/0215945	A1	9/2005	Harris et al.
				2005/0222532	A1	10/2005	Bertolero et al.
				2005/0240102	A1	10/2005	Rachlin et al.
				2005/0245811	A1	11/2005	Scheffler

(56)

References Cited

U.S. PATENT DOCUMENTS

2005/0256398 A1	11/2005	Hastings et al.	2007/0225610 A1	9/2007	Mickley et al.
2005/0256451 A1	11/2005	Adams et al.	2007/0232882 A1	10/2007	Glossop et al.
2005/0256521 A1	11/2005	Kozel	2007/0232896 A1	10/2007	Gilboa et al.
2005/0256541 A1	11/2005	Stypulkowski	2007/0238984 A1	10/2007	Maschke et al.
2005/0283210 A1	12/2005	Blischak et al.	2007/0239018 A1	10/2007	Fetzer et al.
2005/0283216 A1	12/2005	Pyles	2007/0244413 A1	10/2007	Biggins
2005/0288586 A1	12/2005	Ferek-Petric	2007/0247454 A1	10/2007	Rahn et al.
2006/0009759 A1	1/2006	Chrisitian et al.	2007/0249911 A1	10/2007	Simon
2006/0015003 A1	1/2006	Moaddes et al.	2007/0255270 A1	11/2007	Carney
2006/0025677 A1	2/2006	Verard et al.	2007/0265526 A1	11/2007	Govari et al.
2006/0025697 A1*	2/2006	Kurzweil	2007/0280974 A1	12/2007	Son et al.
		A61B 5/0452	2007/0282196 A1	12/2007	Birk et al.
		600/509	2007/0282197 A1	12/2007	Bill et al.
			2007/0299352 A1	12/2007	Harlev et al.
			2007/0299353 A1	12/2007	Harlev et al.
2006/0058633 A1	3/2006	Hoshino et al.	2008/0004652 A1	1/2008	Abboud et al.
2006/0068074 A1	3/2006	Stefandl	2008/0008745 A1	1/2008	Stinchcomb et al.
2006/0084867 A1	4/2006	Tremblay et al.	2008/0009720 A1	1/2008	Schefelker et al.
2006/0106306 A1	5/2006	Essner et al.	2008/0015442 A1	1/2008	Watson et al.
2006/0116571 A1	6/2006	Maschke et al.	2008/0027320 A1	1/2008	Bolorforosh et al.
2006/0116576 A1	6/2006	McGee et al.	2008/0033283 A1	2/2008	Dellaca et al.
2006/0116578 A1	6/2006	Grunwald et al.	2008/0033316 A1	2/2008	Kassab et al.
2006/0122514 A1	6/2006	Byrd et al.	2008/0033350 A1	2/2008	Wilson et al.
2006/0142656 A1	6/2006	Malackowski et al.	2008/0045908 A1	2/2008	Gould et al.
2006/0149134 A1	7/2006	Soper et al.	2008/0051626 A1	2/2008	Sato et al.
2006/0173251 A1	8/2006	Govari et al.	2008/0077158 A1	3/2008	Haider et al.
2006/0173329 A1	8/2006	Irioka et al.	2008/0081958 A1	4/2008	Denison et al.
2006/0173407 A1	8/2006	Shaughnessy et al.	2008/0082136 A1	4/2008	Gaudiani
2006/0176242 A1	8/2006	Jaramaz et al.	2008/0097232 A1	4/2008	Rothenberg
2006/0184074 A1	8/2006	Vaezy et al.	2008/0108949 A1	5/2008	Beasley et al.
2006/0206037 A1	9/2006	Braxton	2008/0114095 A1	5/2008	Peppmoller et al.
2006/0211944 A1	9/2006	Mauge et al.	2008/0125772 A1	5/2008	Stone et al.
2006/0217655 A1	9/2006	Vitullo et al.	2008/0139944 A1	6/2008	Weymer et al.
2006/0224188 A1	10/2006	Libbus et al.	2008/0146939 A1	6/2008	McMorrow et al.
2006/0247746 A1	11/2006	Danek et al.	2008/0146940 A1	6/2008	Jenkins et al.
2006/0258895 A1	11/2006	Maschke	2008/0146942 A1	6/2008	Dala-Krishna
2006/0276867 A1	12/2006	Viswanathan	2008/0154100 A1	6/2008	Thalmeier et al.
2007/0010753 A1	1/2007	MacAdam	2008/0166453 A1	7/2008	Steele et al.
2007/0016007 A1	1/2007	Govari et al.	2008/0171934 A1	7/2008	Greenan et al.
2007/0016013 A1	1/2007	Camus	2008/0183075 A1	7/2008	Govari et al.
2007/0016068 A1	1/2007	Grunwald et al.	2008/0188830 A1	8/2008	Rosenblatt et al.
2007/0016069 A1	1/2007	Grunwald et al.	2008/0190438 A1	8/2008	Harlev et al.
2007/0016070 A1	1/2007	Grunwald et al.	2008/0195169 A1	8/2008	Pinter et al.
2007/0016072 A1	1/2007	Grunwald et al.	2008/0200754 A1	8/2008	Buchalter
2007/0032746 A1	2/2007	Sell	2008/0228082 A1	9/2008	Scheirer et al.
2007/0038113 A1	2/2007	Oonuki et al.	2008/0236598 A1	10/2008	Gobel
2007/0049822 A1	3/2007	Bunce et al.	2008/0255404 A1	10/2008	Nogawa et al.
2007/0049846 A1	3/2007	Bown et al.	2008/0255475 A1	10/2008	Kondrosky et al.
2007/0055141 A1	3/2007	Kruger et al.	2008/0269581 A1	10/2008	Wood et al.
2007/0055142 A1	3/2007	Webler	2008/0269611 A1	10/2008	Pedrizetti et al.
2007/0060992 A1	3/2007	Pappone	2008/0275465 A1	11/2008	Paul et al.
2007/0062544 A1	3/2007	Rauk Bergstrom et al.	2008/0275765 A1	11/2008	Kuchar
2007/0066888 A1	3/2007	Maschke	2008/0288038 A1	11/2008	Paul et al.
2007/0073155 A1	3/2007	Park et al.	2008/0294041 A1	11/2008	Kassab
2007/0087038 A1	4/2007	Richardson et al.	2008/0319350 A1	12/2008	Wallace et al.
2007/0093710 A1	4/2007	Maschke	2009/0005674 A1	1/2009	Saadat et al.
2007/0100236 A1	5/2007	McMorrow et al.	2009/0005675 A1	1/2009	Grunwald et al.
2007/0100285 A1	5/2007	Griffin et al.	2009/0018497 A1	1/2009	Birchard et al.
2007/0112282 A1	5/2007	Skujins et al.	2009/0024018 A1	1/2009	Boyden et al.
2007/0123805 A1	5/2007	Shireman et al.	2009/0030380 A1	1/2009	Binmoeller
2007/0129770 A1	6/2007	Younis	2009/0043205 A1	2/2009	Pelissier et al.
2007/0135803 A1	6/2007	Belson	2009/0062684 A1	3/2009	Gregersen et al.
2007/0135886 A1	6/2007	Maschke	2009/0082661 A1	3/2009	Saladin et al.
2007/0156205 A1	7/2007	Larson et al.	2009/0084382 A1	4/2009	Jalde et al.
2007/0161853 A1	7/2007	Yagi et al.	2009/0101577 A1	4/2009	Fulkerson et al.
2007/0161914 A1	7/2007	Zdeblick et al.	2009/0118612 A1	5/2009	Grunwald et al.
2007/0161915 A1	7/2007	Desai	2009/0118637 A1	5/2009	Kassab et al.
2007/0167738 A1	7/2007	Timinger et al.	2009/0118706 A1	5/2009	Schweikert et al.
2007/0167762 A1	7/2007	Kim et al.	2009/0124901 A1	5/2009	Fink et al.
2007/0167769 A1	7/2007	Ikuma et al.	2009/0143736 A1	6/2009	Mittermeyer et al.
2007/0167801 A1	7/2007	Webler et al.	2009/0156926 A1	6/2009	Messerly et al.
2007/0167997 A1	7/2007	Forsberg et al.	2009/0163810 A1	6/2009	Kanade et al.
2007/0197891 A1*	8/2007	Shachar	2009/0171217 A1	7/2009	Kim et al.
		A61B 5/0402	2009/0177083 A1	7/2009	Matsumura
		600/374	2009/0177090 A1	7/2009	Grunwald et al.
2007/0197905 A1	8/2007	Timinger et al.	2009/0203989 A1	8/2009	Burnside et al.
2007/0208255 A1	9/2007	Ridley et al.	2009/0204113 A1	8/2009	MacAdam et al.
2007/0219453 A1	9/2007	Kremlivsky et al.	2009/0209872 A1	8/2009	Pop
2007/0225589 A1	9/2007	Viswanathan	2009/0209950 A1	8/2009	Starksen

(56)

References Cited

U.S. PATENT DOCUMENTS

- | | | | |
|--------------|----|---------|-------------------------|
| 2009/0221908 | A1 | 9/2009 | Glossop |
| 2009/0227952 | A1 | 9/2009 | Blakstvedt et al. |
| 2009/0234328 | A1 | 9/2009 | Cox et al. |
| 2009/0253976 | A1 | 10/2009 | Harlev et al. |
| 2009/0258171 | A1 | 10/2009 | Uang |
| 2009/0259124 | A1 | 10/2009 | Rothenberg |
| 2009/0262982 | A1 | 10/2009 | Markowitz et al. |
| 2009/0270729 | A1 | 10/2009 | Corbucci et al. |
| 2009/0270746 | A1 | 10/2009 | Min |
| 2009/0275828 | A1 | 11/2009 | Shachar et al. |
| 2009/0297441 | A1 | 12/2009 | Canham et al. |
| 2010/0004543 | A1 | 1/2010 | Ahlund et al. |
| 2010/0004547 | A1 | 1/2010 | Scholz et al. |
| 2010/0010355 | A1 | 1/2010 | Kassab |
| 2010/0010444 | A1 | 1/2010 | Bettuchi |
| 2010/0010612 | A1 | 1/2010 | Gelbart et al. |
| 2010/0016726 | A1 | 1/2010 | Meier |
| 2010/0036227 | A1 | 2/2010 | Cox et al. |
| 2010/0036284 | A1 | 2/2010 | Laynes et al. |
| 2010/0041973 | A1 | 2/2010 | Vu et al. |
| 2010/0041984 | A1 | 2/2010 | Shapland et al. |
| 2010/0049062 | A1 | 2/2010 | Ziv |
| 2010/0055153 | A1 | 3/2010 | Majmudar |
| 2010/0055184 | A1 | 3/2010 | Zeitels et al. |
| 2010/0057157 | A1 | 3/2010 | Govari et al. |
| 2010/0060472 | A1 | 3/2010 | Kimura et al. |
| 2010/0063401 | A1 | 3/2010 | Nishina et al. |
| 2010/0076305 | A1 | 3/2010 | Maier-Hein et al. |
| 2010/0076328 | A1 | 3/2010 | Matsumura et al. |
| 2010/0081934 | A1 | 4/2010 | Soltani et al. |
| 2010/0083719 | A1 | 4/2010 | Peppmoller et al. |
| 2010/0094116 | A1 | 4/2010 | Silverstein |
| 2010/0106011 | A1 | 4/2010 | Byrd et al. |
| 2010/0114573 | A1 | 5/2010 | Huang et al. |
| 2010/0117659 | A1 | 5/2010 | Osadchy et al. |
| 2010/0143119 | A1 | 6/2010 | Kooijman et al. |
| 2010/0152596 | A1 | 6/2010 | Griffiths et al. |
| 2010/0168557 | A1 | 7/2010 | Deno et al. |
| 2010/0185097 | A1 | 7/2010 | Hall |
| 2010/0198048 | A1 | 8/2010 | Togawa |
| 2010/0198346 | A1 | 8/2010 | Keogh et al. |
| 2010/0204569 | A1 | 8/2010 | Burnside et al. |
| 2010/0204614 | A1 | 8/2010 | Lindquist et al. |
| 2010/0210938 | A1 | 8/2010 | Verard et al. |
| 2010/0210950 | A1 | 8/2010 | Dunbar et al. |
| 2010/0217116 | A1 | 8/2010 | Eck et al. |
| 2010/0222664 | A1 | 9/2010 | Lemon et al. |
| 2010/0222786 | A1 | 9/2010 | Kassab |
| 2010/0234724 | A1 | 9/2010 | Jacobsen et al. |
| 2010/0234733 | A1 | 9/2010 | Wahlheim |
| 2010/0249598 | A1 | 9/2010 | Smith et al. |
| 2010/0258033 | A1 | 10/2010 | Yang et al. |
| 2010/0268059 | A1 | 10/2010 | Ryu et al. |
| 2010/0273895 | A1 | 10/2010 | Stinchcomb et al. |
| 2010/0291521 | A1 | 11/2010 | Simon |
| 2010/0298702 | A1 | 11/2010 | Rogers et al. |
| 2010/0298704 | A1 | 11/2010 | Pelissier et al. |
| 2010/0298705 | A1 | 11/2010 | Pelissier et al. |
| 2010/0298712 | A1 | 11/2010 | Pelissier et al. |
| 2010/0312086 | A9 | 12/2010 | Beatty et al. |
| 2010/0317981 | A1 | 12/2010 | Grunwald |
| 2010/0318026 | A1 | 12/2010 | Grunwald |
| 2010/0331712 | A1 | 12/2010 | Rothenberg |
| 2011/0015527 | A1 | 1/2011 | Heasty et al. |
| 2011/0015533 | A1 | 1/2011 | Cox et al. |
| 2011/0034823 | A1 | 2/2011 | Gelbart et al. |
| 2011/0034940 | A1 | 2/2011 | Payner |
| 2011/0040212 | A1 | 2/2011 | Dietz et al. |
| 2011/0052694 | A1 | 3/2011 | Stinchcomb et al. |
| 2011/0087105 | A1 | 4/2011 | Ridley et al. |
| 2011/0087106 | A1 | 4/2011 | Ridley et al. |
| 2011/0087107 | A1 | 4/2011 | Lindekugel et al. |
| 2011/0112396 | A1 | 5/2011 | Shachar et al. |
| 2011/0136242 | A1 | 6/2011 | Marx et al. |
| 2011/0137156 | A1 | 6/2011 | Razzaque et al. |
| 2011/0196235 | A1 | 8/2011 | Dunbar et al. |
| 2011/0196248 | A1 | 8/2011 | Grunwald |
| 2011/0196255 | A1 | 8/2011 | Kassab |
| 2011/0237935 | A1 | 9/2011 | Kalpin et al. |
| 2011/0245659 | A1 | 10/2011 | Ma et al. |
| 2011/0282187 | A1 | 11/2011 | Harlev et al. |
| 2011/0282188 | A1 | 11/2011 | Burnside et al. |
| 2011/0295108 | A1 | 12/2011 | Cox et al. |
| 2011/0306867 | A1 | 12/2011 | Gopinathan et al. |
| 2011/0313293 | A1 | 12/2011 | Lindekugel et al. |
| 2012/0004564 | A1 | 1/2012 | Dobak, III |
| 2012/0035460 | A1 | 2/2012 | Stangenes et al. |
| 2012/0046562 | A1 | 2/2012 | Powers et al. |
| 2012/0059249 | A1 | 3/2012 | Verard et al. |
| 2012/0059270 | A1 | 3/2012 | Grunwald |
| 2012/0071751 | A1 | 3/2012 | Sra et al. |
| 2012/0071759 | A1 | 3/2012 | Hagy et al. |
| 2012/0071782 | A1 | 3/2012 | Patil et al. |
| 2012/0078342 | A1 | 3/2012 | Vollkron et al. |
| 2012/0095319 | A1 | 4/2012 | Kondrosky et al. |
| 2012/0108950 | A1 | 5/2012 | He et al. |
| 2012/0143029 | A1 | 6/2012 | Silverstein et al. |
| 2012/0143078 | A1 | 6/2012 | Kassab et al. |
| 2012/0172727 | A1 | 7/2012 | Hastings et al. |
| 2012/0220854 | A1 | 8/2012 | Messerly et al. |
| 2012/0283582 | A1 | 11/2012 | Mahapatra et al. |
| 2012/0296200 | A1 | 11/2012 | Shachar et al. |
| 2012/0310052 | A1 | 12/2012 | Mahapatra et al. |
| 2012/0310066 | A1 | 12/2012 | Shachar et al. |
| 2012/0316440 | A1 | 12/2012 | Munrow et al. |
| 2013/0006102 | A1 | 1/2013 | Wilkes et al. |
| 2013/0018248 | A1 | 1/2013 | Hurezan |
| 2013/0035590 | A1 | 2/2013 | Ma et al. |
| 2013/0041269 | A1 | 2/2013 | Stahmann et al. |
| 2013/0060116 | A1 | 3/2013 | Messerly et al. |
| 2013/0085416 | A1 | 4/2013 | Mest |
| 2013/0102890 | A1 | 4/2013 | Dib |
| 2013/0123597 | A1 | 5/2013 | Rothenberg |
| 2013/0169272 | A1 | 7/2013 | Eichler et al. |
| 2013/0217999 | A1 | 8/2013 | Burnside et al. |
| 2013/0245434 | A1 | 9/2013 | Messerly et al. |
| 2013/0296691 | A1 | 11/2013 | Ashe |
| 2013/0303896 | A1 | 11/2013 | Kalpin et al. |
| 2013/0317338 | A1 | 11/2013 | Silverstein |
| 2013/0324841 | A1 | 12/2013 | Kamen et al. |
| 2013/0338503 | A1 | 12/2013 | Cohen et al. |
| 2013/0338517 | A1 | 12/2013 | Rothenberg |
| 2013/0345555 | A1 | 12/2013 | Kanade et al. |
| 2014/0031674 | A1 | 1/2014 | Newman et al. |
| 2014/0046261 | A1 | 2/2014 | Newman et al. |
| 2014/0094694 | A1 | 4/2014 | Moctezuma de la Barrera |
| 2014/0094768 | A1 | 4/2014 | Stangenes et al. |
| 2014/0107475 | A1 | 4/2014 | Cox et al. |
| 2014/0163356 | A2 | 6/2014 | Burnside et al. |
| 2014/0180074 | A1 | 6/2014 | Green et al. |
| 2014/0187990 | A1 | 7/2014 | Banet et al. |
| 2014/0188133 | A1 | 7/2014 | Misener |
| 2014/0228689 | A1 | 8/2014 | Ishikawa et al. |
| 2014/0243659 | A1 | 8/2014 | Rothenberg |
| 2014/0257080 | A1 | 9/2014 | Dunbar et al. |
| 2014/0275957 | A1 | 9/2014 | Lupotti |
| 2014/0275990 | A1 | 9/2014 | Hagy et al. |
| 2014/0303492 | A1 | 10/2014 | Burnside et al. |
| 2014/0309624 | A1 | 10/2014 | Bown et al. |
| 2014/0343398 | A1 | 11/2014 | He et al. |
| 2015/0005621 | A1 | 1/2015 | Liu |
| 2015/0025402 | A1 | 1/2015 | Rothenberg |
| 2015/0051489 | A1 | 2/2015 | Caluser et al. |
| 2015/0080716 | A1 | 3/2015 | Powers et al. |
| 2015/0297114 | A1 | 10/2015 | Cox et al. |

FOREIGN PATENT DOCUMENTS

- | | | |
|----|---------------|---------|
| AU | 20009592 | 9/2000 |
| AU | 20015250 | 6/2001 |
| AU | 768362 B2 | 12/2003 |
| AU | 2001229024 B2 | 9/2005 |
| AU | 2001283703 B2 | 5/2006 |
| AU | 2006202149 | 6/2006 |

(56)

References Cited

FOREIGN PATENT DOCUMENTS

AU	2006904933	9/2006	WO	9641119	12/1996
AU	2006283022 B2	2/2012	WO	9729683 A1	8/1997
CA	2420676	2/2002	WO	9743989 A1	11/1997
CA	2619909 C	1/2014	WO	9825159 A1	6/1998
CN	2031655 U	2/1989	WO	98/29032 A1	7/1998
CN	1672649 A	9/2005	WO	9835611 A1	8/1998
CN	102209490 A	10/2011	WO	9916495 A1	4/1999
CN	102802514 A	11/2012	WO	9927837 A2	6/1999
CN	102821679 A	12/2012	WO	9949407 A1	9/1999
CN	103037761 A	4/2013	WO	0019906	4/2000
CN	103037762 A	4/2013	WO	0027281 A1	5/2000
CN	103118591 A	5/2013	WO	0040155	7/2000
CN	103189009 A	7/2013	WO	0063658 A2	10/2000
DE	4319033 C1	6/1994	WO	0074775 A1	12/2000
EP	0359697	3/1990	WO	0113792 A1	3/2001
EP	0362821	4/1990	WO	0139683 A1	6/2001
EP	0399536 A1	11/1990	WO	0176479 A1	10/2001
EP	0823261 A2	2/1998	WO	0215973 A1	2/2002
EP	0928976 A2	7/1999	WO	0219905 A1	3/2002
EP	1025805 A1	8/2000	WO	0225277 A1	3/2002
EP	1311226 A1	5/2003	WO	02085442 A1	10/2002
EP	1504713 A1	2/2005	WO	03061752	7/2003
EP	1932477 A1	6/2008	WO	03077759 A1	9/2003
EP	2313143 A1	4/2011	WO	03/088833 A1	10/2003
EP	2337491 A1	6/2011	WO	03091495 A1	11/2003
EP	2440122 A1	4/2012	WO	2004002303 A1	1/2004
EP	2464407 A2	6/2012	WO	2004049970 A2	6/2004
EP	2482719 A1	8/2012	WO	2005033524 A1	4/2005
EP	2575610 A1	4/2013	WO	2005033574 A1	4/2005
EP	2575611 A1	4/2013	WO	2005117690 A1	12/2005
EP	2603145 A2	6/2013	WO	2005117733 A2	12/2005
EP	2605699 A2	6/2013	WO	2006074509 A1	7/2006
EP	2632360 A1	9/2013	WO	2006074510 A1	7/2006
EP	2219526 B1	3/2014	WO	2006078677 A2	7/2006
EP	2712547 A1	4/2014	WO	2006103661 A2	10/2006
FR	2545349	11/1984	WO	2006111056 A1	10/2006
JP	01097440	4/1989	WO	2007002541 A2	1/2007
JP	03173542 A	7/1991	WO	2007005976 A1	1/2007
JP	4090741	8/1992	WO	2007014447 A1	2/2007
JP	9-503054	3/1997	WO	2007034196 A2	3/2007
JP	09-094298 A	4/1997	WO	2007067324 A1	6/2007
JP	10043310	2/1998	WO	2007069168 A2	6/2007
JP	10290839 A	11/1998	WO	2007109123 A2	9/2007
JP	11128237 A	5/1999	WO	2007126536 A2	11/2007
JP	2001161683	6/2001	WO	2007144894 A1	12/2007
JP	2001-514533 A	9/2001	WO	2008005480 A1	1/2008
JP	2001-524339 A	12/2001	WO	2008024596 A2	2/2008
JP	2001340334	12/2001	WO	2008028253	3/2008
JP	2002-529133 A	9/2002	WO	2008083111	7/2008
JP	2002-541947 A	12/2002	WO	2008097767 A2	8/2008
JP	2003-010138 A	1/2003	WO	2008118992 A1	10/2008
JP	2003501127 A	1/2003	WO	2008126074 A2	10/2008
JP	2003061752 A	3/2003	WO	2008129326 A1	10/2008
JP	2003299654	10/2003	WO	2008131017 A2	10/2008
JP	2003334191	11/2003	WO	2008136008 A2	11/2008
JP	2002520893	2/2004	WO	2009000439 A1	12/2008
JP	2004505748 T	2/2004	WO	2009002514 A2	12/2008
JP	2004515298 A	5/2004	WO	2009003138 A1	12/2008
JP	2006508744 A	3/2006	WO	2009009064 A1	1/2009
JP	2006-338526 A	12/2006	WO	2009057774 A1	5/2009
JP	2007-000226 A	1/2007	WO	2009063166 A1	5/2009
JP	2007-068989 A	3/2007	WO	2009067654 A1	5/2009
JP	2009/271123 A	11/2009	WO	2009070616 A2	6/2009
JP	5010604	6/2012	WO	2009100158 A1	8/2009
JP	2012-529929	11/2012	WO	2009123819 A2	10/2009
JP	2013-518676 A	5/2013	WO	2009126340 A1	10/2009
JP	2013-526959 A	6/2013	WO	2009129475 A1	10/2009
JP	2013-526961 A	6/2013	WO	2009129477 A1	10/2009
WO	8002376 A1	11/1980	WO	2009134605 A2	11/2009
WO	9112836 A1	9/1991	WO	2009137262 A2	11/2009
WO	9203090	3/1992	WO	2010002313 A1	1/2010
WO	9403159 A1	2/1994	WO	2010018500 A1	2/2010
WO	9404938	3/1994	WO	2010022370 A1	2/2010
WO	9605768 A1	2/1996	WO	2010027349 A1	3/2010
WO	9607352 A1	3/1996	WO	2010027471 A2	3/2010
			WO	2010029906 A1	3/2010
			WO	2010030820 A1	3/2010
			WO	2010132857 A1	11/2010
			WO	2010132985 A1	11/2010

(56)

References Cited

FOREIGN PATENT DOCUMENTS

WO	2010143196	A1	12/2010
WO	2010144922	A1	12/2010
WO	2011019760	A2	2/2011
WO	2011041450	A1	4/2011
WO	2011044421	A1	4/2011
WO	2011057289	A2	5/2011
WO	2011064209	A1	6/2011
WO	2011084593	A2	7/2011
WO	2011097312	A1	8/2011
WO	2011128052	A2	10/2011
WO	2011150358	A1	12/2011
WO	2011150376	A1	12/2011
WO	2012021542	A2	2/2012
WO	2012024577	A2	2/2012
WO	2012039866	A1	3/2012
WO	2012040487	A1	3/2012
WO	2012058461	A1	5/2012
WO	2012083245	A1	6/2012
WO	2012088535	A1	6/2012
WO	2012110955	A1	8/2012
WO	2012173697	A1	12/2012
WO	2013006713	A2	1/2013
WO	2013006817	A1	1/2013
WO	2013034175	A1	3/2013
WO	2014052894	A2	4/2014
WO	2014062728	A1	4/2014
WO	2014138652	A1	9/2014
WO	2014138918	A1	9/2014
WO	2015/120256	A2	8/2015

OTHER PUBLICATIONS

U.S. Appl. No. 13/213,622, filed Aug. 19, 2011 Final Office Action dated Feb. 19, 2013.

U.S. Appl. No. 13/213,622, filed Aug. 19, 2011 Non-Final Office Action dated Jul. 31, 2012.

U.S. Appl. No. 13/213,622, filed Aug. 19, 2011 Non-Final Office Action dated May 22, 2014.

U.S. Appl. No. 13/283,395, filed Oct. 27, 2011 Non-Final Office Action dated Apr. 23, 2013.

U.S. Appl. No. 13/336,919, filed Dec. 23, 2011 Advisory Action dated May 23, 2013.

U.S. Appl. No. 13/336,919, filed Dec. 23, 2011 Final Office Action dated Mar. 1, 2013.

U.S. Appl. No. 13/336,919, filed Dec. 23, 2011 Non-Final Office Action dated Dec. 27, 2013.

U.S. Appl. No. 13/336,919, filed Dec. 23, 2011 Non-Final Office Action dated Oct. 16, 2012.

U.S. Appl. No. 13/337,987, filed Dec. 27, 2011 Non-Final Office Action dated Mar. 15, 2013.

U.S. Appl. No. 13/469,932, filed May 11, 2012 Non-Final Office Action dated Jan. 3, 2014.

U.S. Appl. No. 13/469,932, filed May 11, 2012 Non-Final Office Action dated Jul. 31, 2014.

U.S. Appl. No. 13/665,420, filed Oct. 31, 2012 Non-Final Office Action dated Jan. 6, 2014.

U.S. Appl. No. 13/737,806, filed Jan. 9, 2013 Notice of Allowance dated Oct. 31, 2013.

U.S. Appl. No. 13/887,166, filed May 3, 2013 Advisory Action dated Aug. 27, 2014.

U.S. Appl. No. 13/887,166, filed May 3, 2013 Final Office Action dated Jun. 23, 2014.

U.S. Appl. No. 13/887,166, filed May 3, 2013 Non-Final Office Action dated Jan. 7, 2014.

U.S. Appl. No. 13/890,158, filed May 8, 2013 Non-Final Office Action dated Aug. 15, 2014.

U.S. Appl. No. 13/969,265, filed Aug. 16, 2013 Non-Final Office Action dated Dec. 19, 2013.

U.S. Appl. No. 13/969,265, filed Aug. 16, 2013 Notice of Allowance dated Jun. 23, 2014.

U.S. Appl. No. 14/141,046, filed Dec. 26, 2013 Non-Final Office Action dated Jun. 20, 2014.

U.S. Appl. No. 14/317,501, filed Jun. 27, 2014 Non-Final Office Action dated Sep. 12, 2014.

U.S. Appl. No. 29/428,649, filed Aug. 1, 2012 Notice of Allowance dated Jul. 5, 2013.

Valdivieso, J.R. Perez, et al., Evaluation of a formula for optimal positioning of a central venous catheter inserted through the right internal jugular vein, *Rev. Esp. Anesthesiol. Reanim.* 2003; 50: 77-79.

VasoNova Inc, Vascular navigation system for accurate placement of PICCs, Start-Up Emerging Medical Ventures, pp. 44-45, vol. 14 No. 7, Jul.-Aug. 2009.

Vesely, Thomas M. et al., Central Venous Catheter Tip Position: A Continuing Controversy, *J Vasc Interv Radiol* 2003; 14:527-534.

VIASYS Health Care Inc. Cortrak © Fact Sheet, 2005.

VIASYS Healthcare MedSystems, Navigator® Benefits, 2008.

VIASYS Healthcare MedSystems, Navigator® Research in Cost Justification, 2008.

VIASYS MedSystems, Cortrak™ Systems Brochure, 2005.

Volcano ComboMap Features and Benefits/Technical Specifications, 2 pages, 2011.

Watters, et al. "Use of Electrocardiogram to Position Right Atrial Catheters During Surgery." *Annals of Surgery*, vol. 225, No. 2, pp. 165-171, 1997.

Welch Allyn Cardioperfect® PC-Based Resting ECG, 2003.

Wilson, R. G. et al, Right Atrial Electrocardiography in Placement of Central Venous Catheters, *The Lancet*, pp. 462-463, Feb. 27, 1988.

Wong, Jeffrey J. et al., Azygos Tip Placement for Hemodialysis Catheters in Patients with Superior Vena Cava Occlusion, *Cardiovasc Intervent Radiol* (2006) 29:143-146.

Worley, Seth J. "Use of a Real-Time Three-Dimensional Magnetic Navigation System for Radiofrequency Ablation of Accessory Pathways." *PACE*, vol. 21 pp. 1636-1643, Aug. 1998.

Yilmazlar A et al, Complications of 1303 Central Venous Cannulations, *JR Soc Med*, pp. 319-321, vol. 90 No. 6, Jun. 1997 (Abstract only).

Yoon, SZ et al, Usefulness of the Carina as a Radiographic Landmark for Central Venous Catheter Placement in Paediatric Patients, *Br J Anaesth*, Jul. 2005.

Yoshida, Teruhisa et al, Detection of Concealed Left Sided Accessory Atrioventricular Pathway by P Wave Signal Averaged Electrocardiogram, *J Am Coll Cardiol*, pp. 55-62, 1999.

Zaaroor, et al. "Novel Magnetic Technology for Intraoperative Intracranial Frameless Navigation: In Vivo and in Vitro Results." *Neurosurgery*, vol. 48, No. 5. pp. 1100-1107, May 2001.

Zachariou, Zacharias et al., Intra-atrial ECG recording: a new and safe method for implantation of Broviac catheters in children, *Pediatr Surg Int* (1994) 9: 457-458.

Zaidi, Naveed A., et al. "Room temperature magnetic order in an organic magnet derived from polyaniline." 2004, *Polymer*, vol. 45, pp. 5683-5689.

U.S. Appl. No. 11/466,602, filed Aug. 23, 2006 Final Office Action dated Jan. 30, 2009.

U.S. Appl. No. 11/466,602, filed Aug. 23, 2006 Final Office Action dated Oct. 28, 2013.

U.S. Appl. No. 11/466,602, filed Aug. 23, 2006 Non-Final Office Action dated Mar. 28, 2013.

U.S. Appl. No. 11/466,602, filed Aug. 23, 2006 Non-Final Office Action dated Sep. 25, 2009.

U.S. Appl. No. 11/466,602, filed Aug. 23, 2006 Notice of Allowance dated Dec. 3, 2012.

U.S. Appl. No. 11/466,602, filed Aug. 23, 2006 Notice of Allowance dated Mar. 14, 2014.

U.S. Appl. No. 11/552,094, filed Oct. 23, 2006 Notice of Allowability dated Apr. 2, 2010.

U.S. Appl. No. 11/552,094, filed Oct. 23, 2006 Non-Final Office Action dated Apr. 27, 2009.

U.S. Appl. No. 11/552,094, filed Oct. 23, 2006 Notice of Allowance dated May 20, 2010.

U.S. Appl. No. 12/104,253, filed Apr. 16, 2008 Final Office Action dated Jul. 27, 2011.

(56)

References Cited

OTHER PUBLICATIONS

- U.S. Appl. No. 12/104,253, filed Apr. 16, 2008 Non-Final Office Action dated Nov. 29, 2010.
- U.S. Appl. No. 12/323,273, filed Nov. 25, 2008 Non-Final Office Action dated Jun. 8, 2012.
- U.S. Appl. No. 12/369,625, filed Feb. 11, 2009 Final Office Action dated Feb. 23, 2012.
- U.S. Appl. No. 12/369,625, filed Feb. 11, 2009 Notice of Allowance dated Oct. 5, 2012.
- U.S. Appl. No. 12/369,625, filed Feb. 11, 2009 Non-Final Office Action dated Jul. 20, 2011.
- U.S. Appl. No. 12/426,175, filed Apr. 17, 2009 Advisory Action dated Nov. 26, 2013.
- U.S. Appl. No. 12/426,175, filed Apr. 17, 2009 Final Office Action dated Aug. 2, 2013.
- U.S. Appl. No. 12/426,175, filed Apr. 17, 2009 Final Office Action dated Jan. 31, 2014.
- U.S. Appl. No. 12/426,175, filed Apr. 17, 2009 Non-Final Office Action dated Dec. 3, 2012.
- U.S. Appl. No. 12/427,244, filed Apr. 21, 2009 Non-Final Office Action dated Jan. 19, 2012.
- U.S. Appl. No. 12/545,762, filed Aug. 21, 2009 Final Office Action dated Mar. 7, 2013.
- U.S. Appl. No. 12/545,762, filed Aug. 21, 2009 Non-Final Office Action dated Aug. 1, 2012.
- U.S. Appl. No. 12/545,762, filed Aug. 21, 2009 Non-Final Office Action dated Dec. 13, 2013.
- U.S. Appl. No. 12/557,401, filed Sep. 10, 2009 Non-Final Office Action dated Apr. 24, 2012.
- U.S. Appl. No. 12/557,401, filed Sep. 10, 2009 Non-Final Office Action dated Jan. 6, 2014.
- U.S. Appl. No. 12/575,456, filed Oct. 7, 2009 Non-Final Office Action dated Oct. 5, 2012.
- U.S. Appl. No. 12/715,556, filed Mar. 2, 2010 Final Office Action dated Oct. 2, 2013.
- U.S. Appl. No. 12/715,556, filed Mar. 2, 2010 Non-Final Office Action dated Sep. 13, 2012.
- U.S. Appl. No. 12/815,331, filed Jun. 14, 2010 Advisory Action dated Oct. 4, 2013.
- U.S. Appl. No. 12/815,331, filed Jun. 14, 2010 Final Office Action dated Jul. 26, 2013.
- U.S. Appl. No. 12/815,331, filed Jun. 14, 2010 Non-Final Office Action dated Jan. 22, 2013.
- U.S. Appl. No. 12/815,331, filed Jun. 14, 2010 Non-Final Office Action dated Jul. 2, 2014.
- U.S. Appl. No. 12/854,083, filed Aug. 10, 2010 Advisory Action dated Sep. 8, 2014.
- U.S. Appl. No. 12/854,083, filed Aug. 10, 2010 Final Office Action dated Aug. 15, 2013.
- U.S. Appl. No. 12/854,083, filed Aug. 10, 2010 Final Office Action dated Jul. 1, 2014.
- U.S. Appl. No. 12/854,083, filed Aug. 10, 2010 Non-Final Office Action dated Jan. 29, 2013.
- U.S. Appl. No. 12/854,083, filed Aug. 10, 2010 Non-Final Office Action dated Jan. 29, 2014.
- U.S. Appl. No. 12/878,915, filed Sep. 9, 2010 Final Office Action dated Sep. 26, 2012.
- U.S. Appl. No. 12/878,915, filed Sep. 9, 2010 Non-Final Office Action dated Mar. 15, 2012.
- U.S. Appl. No. 12/878,915, filed Sep. 9, 2010 Notice of Allowance dated Jan. 8, 2013.
- U.S. Appl. No. 12/893,916, filed Sep. 29, 2010 Advisory Action dated Aug. 15, 2014.
- U.S. Appl. No. 12/893,916, filed Sep. 29, 2010 Final Office Action dated Jun. 18, 2014.
- U.S. Appl. No. 12/893,916, filed Sep. 29, 2010 Non-Final Office Action dated Dec. 24, 2013.
- U.S. Appl. No. 12/900,750, filed Oct. 8, 2010 Non-Final Office Action dated Jun. 3, 2013.
- U.S. Appl. No. 13/019,939, filed Feb. 2, 2011 Final Office Action dated Apr. 2, 2014.
- U.S. Appl. No. 13/019,939, filed Feb. 2, 2011 Non-Final Office Action dated Oct. 11, 2013.
- U.S. Appl. No. 13/118,033, filed May 27, 2011 Non-Final Office Action dated Aug. 1, 2013.
- U.S. Appl. No. 13/118,033, filed May 27, 2011 Non-Final Office Action dated May 22, 2014.
- U.S. Appl. No. 13/118,138, filed May 27, 2011 Final Office Action dated Apr. 3, 2013.
- Claasz, Antonia et al, A Study of the Relationship of the Superior Vena Cava to the Bony Landmarks of the Sternum in the Supine Adult: Implications for Magnetic Guidance Systems, *Journal*, vol. 12 No. 3, JAVA, Jul. 24, 2007.
- Clifford, et al. "Assessment of Hepatic Motion Secondary to Respiration for Computer Assisted Interventions." *Computer Aided Surgery*, vol. 7, pp. 291-299, 2002.
- CN 200880012117.4 filed Apr. 16, 2008 First Office Action dated Dec. 23, 2011.
- CN 200880012117.4 filed Apr. 16, 2008 Second Office Action dated Oct. 8, 2012.
- CN 200880012117.4 filed Apr. 16, 2008 Third Office Action dated Apr. 27, 2013.
- CN 200880125528.4 filed Nov. 25, 2008 First Office Action dated Jun. 5, 2012.
- CN 200880125528.4 filed Nov. 25, 2008 Second Office Action dated Mar. 6, 2013.
- CN 200880125528.4 filed Nov. 25, 2008 Third Office Action dated Jul. 1, 2013.
- CN 200980123021.X filed Dec. 17, 2010 First Office Action dated Nov. 19, 2012.
- CN 200980123021.X filed Dec. 17, 2010 Second Office Action dated Aug. 13, 2013.
- CN 200980123021.X filed Dec. 17, 2010 Third Office Action dated Apr. 22, 2014.
- CN 200980144663.8 filed May 9, 2011 First Office Action dated Dec. 5, 2012.
- CN 200980144663.8 filed May 9, 2011 Second Office Action dated Aug. 22, 2013.
- CN 200980144663.8 filed May 9, 2011 Third Office Action dated May 4, 2014.
- CN 201080035659.0 filed Feb. 10, 2012 First Office Action dated Jan. 26, 2014.
- CN 201080053838.7 filed May 28, 2012 First Office Action dated Jan. 6, 2014.
- CN 201080053838.7 filed May 28, 2012 Second Office Action dated Jun. 17, 2014.
- CN 201180016462.7 filed Sep. 27, 2012 First Office Action dated Mar. 21, 2014.
- Colley, Peter S et al, ECG-Guided Placement of Sorenson CVP Catheters via Arm Veins, Anesthesia and Analgesia, pp. 953-956, vol. 63, 1984.
- Collier, PE et al, Cardiac Tamponade from Central Venous Catheters, *Am J Surg*, pp. 212-214, vol. 176 No. 2, Aug. 1998.
- ComboWire® Pressure/Flow Guide Wire Ref 9500 Series, Instructions for Use, Apr. 2011.
- Corsten, et al., "Central Placement Catheter Placement Using the ECG-Guided Cavafix-Certodyn SD Catheter." *Journal of Clinical Anesthesiology*, vol. 6, Nov./Dec. 1994.
- Cucchiara, Roy et al, Time Required and Success Rate of Percutaneous Right Atrial Catheterization: Description of a Technique, *Canad. Anaesth. Soc. J.*, pp. 572-573, vol. 27, No. 6, Nov. 1980.
- Cullinane, DC et al, The Futility of Chest Roentgenograms Following Routine Central Venous Line Changes, *Am J Surg*, pp. 283-285, vol. 176 No. 3, Sep. 1998.
- Curet, Myriam J. et al., University and Practice-based Physicians' Input on the Content of a Surgical Curriculum, *The American Journal of Surgery*® vol. 178 Jul. 1999, 78-84.
- David, et al., "Is ECG-Guidance a Helpful Method to Correctly Position a Central Venous Catheter During Prehospital Emergency Care?" *ACTA Anaesthesiologica Scandinavica*, vol. 49, pp. 1010-1014, 2005.

(56)

References Cited

OTHER PUBLICATIONS

- DELTEC Cath-Finder® Tracking System Operation Manual, 1994.
- Egelhof, Petra, Effects of Somatostatin on Portal Blood Flow and Portal Vein Pressure in Patients with Portal Hypertension due to Liver Cirrhosis Invasive Monitoring during TIPSS Procedures, Dissertation submitted to: Technical University of Munich, Faculty of Medicine, May 13, 2002; Date of examination: Feb. 26, 2003.
- Engelhardt, W et al. ECG-Controlled Placement of Central Venous Catheters in Patients with Atrial Fibrillation, Anaesthesist, pp. 476-479, vol. 38 No. 9, Sep. 1989 (Abstract only).
- EP 08855396.1 filed Jun. 15, 2010 European Search Report dated Jul. 31, 2012.
- EP 08855396.1 filed Jun. 15, 2010 Intent to Grant dated Jul. 5, 2013.
- EP 09707467.8 supplemental European search report dated Jun. 18, 2013.
- EP 09808901.4 filed Aug. 21, 2009 European Search Report dated May 23, 2012.
- EP 09808901.4 filed Aug. 21, 2009 Examination Report dated May 10, 2013.
- EP 09813632.8 filed Apr. 5, 2011 European Search Report dated Jul. 4, 2012.
- EP 09813632.8 filed Apr. 5, 2011 Office Action dated Apr. 30, 2013.
- EP 09813632.8 filed Apr. 5, 2011 Summons to Attend Oral Proceedings dated Apr. 16, 2014.
- EP 10 808 660.4 filed Feb. 15, 2012 Extended European Search Report dated Mar. 4, 2014.
- EP 10786978.6 filed Dec. 19, 2011 Extended European Search Report dated Mar. 7, 2014.
- EP 12177438.4 filed Jul. 23, 2012 Communication dated Jan. 13, 2014.
- EP 12177438.4 filed Jul. 23, 2012 European Search Report dated Dec. 4, 2012.
- EP 12177438.4 filed Jul. 23, 2012 extended European Search Report dated Mar. 25, 2013.
- EP 13194818.4 filed Nov. 28, 2013 extended European search report dated Feb. 28, 2014.
- EP 14151268.1 filed Jan. 15, 2014 European Search Report dated Feb. 21, 2014.
- Fearon, William F et al, Evaluating Intermediate Coronary Lesions in the Cardiac Catheterization Laboratory, vol. 4, No. 1, 7 pages, Reviews in Cardiovascular Medicine, 2003.
- Felleiter P et al, Use of Electrocardiographic Placement Control of Central Venous Catheters in Austria, Acta Med Austriaca, pp. 109-113, vol. 26 No. 3, 1999 (Abstract only).
- Forauer, AR et al, Change in Peripherally Inserted Central Catheter Tip Location with Abduction and Adduction of the Upper Extremity, J Vasc Intery Radiol, pp. 1315-1318, vol. 11 No. 10, Nov.-Dec. 2000.
- Frassinelli, P et al, Utility of Chest Radiographs after Guidewire Exchanges of Central Venous Catheters, Crit Care Med, pp. 611-615, vol. 26 No. 3, Mar. 1998.
- Frazin L et al, A Doppler Guided Retrograde Catheterization System, Cathet. Cardiovasc Diagn, pp. 41-50, May 1992.
- French, PJ et al, Sensors for Catheter Applications, Sensors Update, vol. 13 Issue 1 pp. 107-153, Dec. 2003.
- GB Application 0800474.9 filed Aug. 24, 2006 Office Action dated Aug. 9, 2010.
- GB Application 0800474.9 filed Aug. 24, 2006 Office Action dated Mar. 17, 2010.
- Gebauer, B et al, Ultrasound and Fluoroscopy-guided Implantation of Peripherally Inserted Central Venous Catheters (PICCs), ROFO, pp. 386-391, vol. 176 No. 3, Mar. 2004 (Abstract only).
- Gebhard, et al., "The accuracy of Electrocardiogram-Controlled Central Line Placement." The International Anesthesia Research Society, vol. 104, No. 1 Jan. 2007.
- Gjendemsjo, Anders, et al., Energy and Power, The Connexions Project, Version 1.2, Feb. 20, 2004.
- Gladwin, MT et al, Cannulation of the Internal Jugular Vein: is postprocedural chest radiography always necessary?, Crit Care Med, 33 pages, Oct. 2000.
- Gonzales, et al. "Peripherally Inserted Central Catheter Placement in Swine Using Magnet Detection." Journal of Intravenous Nursing, vol. 22, No. 3, May/June. 1999.
- Greenall, M.J. et al, Cardiac Tamponade and Central Venous Catheters, British Medical Journal, pp. 595-597, Jun. 14, 1975.
- Guillory, "Basic Principles of Technologies for Catheter Localization." C.R. Bard internal paper, Oct. 20, 2004.
- Guth, AA, Routine Chest X-rays after Insertion of Implantable Long-Term Venous Catheters: Necessary or Not?, Am Surg, pp. 26-29, vol. 67 No. 1, Jan. 2001 (Abstract only).
- Hill, Bradley et al, Abstract of article discussing VasaNova VPS as guide for placement of PICCs. 2009.
- Hill, Bradley, Identifying the Caval-Atrial Junction Using Smart-Catheter Technology presentation, 22nd Annual Scientific Meeting of the AVA in Savannah, Georgia, Sep. 13, 2008.
- Hoffman, Thomas et al, Simultaneous Measurement of Pulmonary Venous Flow by Intravascular Catheter Doppler Velocimetry and Transesophageal Doppler Echocardiography: Relation to Left Atrial Pressure and Left Atrial and Left Ventricular Function, pp. 239-249, J Am Coll Cardiol, Jul. 1995.
- Hoffmann, et al. "New Procedure in Transesophageal Echocardiography: Multiplane Transesophageal Echocardiography and Transesophageal Stress Echocardiography." Herz, vol. 18, No. 5, pp. 269-277, Oct. 1993.
- Iacopino, Domenico Gerardo et al, Intraoperative Microvascular Doppler Monitoring of Blood Flow within a Spinal Dural Arteriovenous Fistula: A Precious Surgical Tool, vol. 10, 5 pages, Neurosurg. Focus, Feb. 2001.
- Jeon, Yunseok et al., "Transesophageal Echocardiographic Evaluation of ECG-guided Central Venous Catheter Placement," Canadian Journal of Anesthesia, vol. 53, No. 10, Oct. 1, 2006, pp. 978-983.
- Joosting, Jean-Pierre, "Dual-interface RFID-compatible EEPROM enables remote access to electronic device parameters," EE Times, Mar. 8, 2010.
- JP 2008-528151 filed Aug. 24, 2006 Notice of Grant dated May 6, 2012.
- JP 2010-504220 filed Sep. 3, 2009 Final Office Action dated Apr. 18, 2013.
- JP 2010-504220 filed Sep. 3, 2009 Office Action dated May 21, 2012.
- JP 2010-535117 filed May 26, 2011 First Office Action dated Aug. 5, 2013.
- JP 2012-515222 filed Dec. 9, 2011 Office Action dated Mar. 24, 2014.
- Kim, Ko et al, Positioning Internal Jugular Venous Catheters using the Right Third Intercostal Space in Children, Acta Anaesthesiol Scand, pp. 1284-1286, vol. 47 No. 10, Nov. 2003.
- Kjelstrup T et al, Positioning of Central Venous Catheters using ECG, Tidsskr nor Laegeforen, pp. 599-601, vol. 111 No. 5, Feb. 1999 (Abstract only).
- Kofler, Julia, et al., Epinephrine application via an endotracheal airway and via the Combitube in esophageal position, Critical Care Medicine: May 2000, vol. 28: Issue 5, pp. 1445-1449.
- Konings, MK, et al., Development of an intravascular impedance catheter for detection of fatty lesions in arteries, IEEE Trans Med Imaging Aug. 1997; 16(4):439-46.
- Kowalski, CM et al, Migration of Central Venous Catheters: Implications for Initial Catheter Tip Positioning, J Vasc Interv Radiol, pp. 443-447, vol. 8 No. 3, May-June. 1997.
- Leowenthal, MR et al, The Peripherally Inserted Central Catheter (PICC): A Prospective Study of its Natural History after Fossa Insertion, Anaesth Intensive Care, pp. 21-24; vol. 30 No. 1, Feb. 2002.
- Lepage Ronan et al. ECG Segmentation and P-wave Feature Extraction: Application to Patients Prone to Atrial Fibrillation, IEEE/EMBS Proceedings, 23rd Annual Conference, Istanbul, Turkey, Oct. 25-28, 2001.
- Liu, Ji-Bin et al, Catheter-Based Intraluminal Sonography, J Ultrasound Med, pp. 145-160, vol. 23, 2004.

(56)

References Cited

OTHER PUBLICATIONS

- Lucey, B et al, Routine Chest Radiographs after Central Line Insertion: Mandatory Postprocedural Evaluation or Unnecessary Waste of Resources?, *Cardiovasc Intervent Radiol*, pp. 381-384, vol. 22 No. 5, Sep.-Oct. 1999.
- Lum, Phillip, A New Formula-Based Measurement Guide for Optimal Positioning of Central Venous Catheters, *JAVA*, vol. 9, No. 2, pp. 80-85, 2004.
- Lynch, RE et al, A Procedure for Placing Pediatric Femoral Venous Catheter Tips near the Right Atrium, *Pediatr Emerg Care*, pp. 130-132, vol. 18 No. 2, Apr. 2002.
- Madan, et al. "Right Atrial Electrocardiography: A Technique for the Placement of Central Venous Catheters for Chemotherapy or Intravenous Nutrition." *British Journal of Surgery*, vol. B1, pp. 1604-1605, 1994.
- Madias, John E, Intracardiac (Superior Vena Cava/Right Atrial) ECGs using Saline Solution as the Conductive Medium for the Proper Positioning of the Shiley Hemodialysis Catheter: Is it Not Time to Forego the Postinsertion Chest Radiograph?, pp. 2363-2367, *CHEST*, 2003.
- Markovich, Mary B., Central Venous Catheter Tip Placement: Determination of Posterior Malposition—A Case Study, *JAVA*, vol. 11, No. 2, pp. 85-89, 2006.
- Martin, Roy W, An Ultrasound Catheter for Intravascular Measurement of Blood Flow: Technical Details, *IEEE Transactions on Sonics and Ultrasonics*, vol. SU-27, No. 6, pp. 277-286, Nov. 1980.
- McDonnall, "Intra-Atrial Electrocardiography (ECG) for Catheter Placement." Literature review prepared for Bard Access Systems, Oct. 2007.
- McGee et al., "Accurate Placement of Central Venous Catheters: A Prospective, Randomize, Multicenter Trial." *Critical Care Medicine*, vol. 21 No. 8, Aug. 1993.
- MedGraphics, CardioPerfect® Resting/Stress ECG System, 3 pages, 2001.
- Michenfelder, John et al, Air Embolism During Neurosurgery—An Evaluation of Right-Atrial Catheters for Diagnosis and Treatment, *JAMA*, pp. 1353-1358, vol. 208, No. 8, May 26, 1969.
- Michenfelder, John et al, Air Embolism During Neurosurgery. A New Method of Treatment, *Anesthesia and Analgesia. Current Researches*, pp. 390-395, vol. 45, No. 4, Jul.-Aug. 1966.
- MICROBIRD™ Miniaturized DC Magnetic Sensors for Intra-body Navigation and Localization, Specifications, 2005.
- MICRONIX CathRite™ Cardiac Access Device Brochure. Jun. 2004.
- Micronix Pty Ltd "CathRite" Guiding Styled Core Manufacturing, Jun. 15, 2006.
- Murthy, Vrudhula et al, Analysis of Power Spectral Densities of Electrocardiograms, *Mathematical Biosciences*, pp. 41-51, vol. 12 No. 1-2, Oct. 1971.
- Nadroo, AM et al, Changes in Upper Extremity Position Cause Migration of Peripherally Inserted Central Catheters in Neonates, *Pediatrics*, pp. 131-136, vol. 110, Jul. 2002.
- Nakatani, K et al, Accurate Placement of Central Venous Catheters—ECG-guided method vs Patient Height Method, *MASUI*, pp. 34-38, vol. 51 No. 1, Jan. 2002.
- Nazarian, GK et al, Changes in Tunneled Catheter Tip Position when a patient is Upright, *J Vasc Interv Radiol*, pp. 437-441, vol. 8 No. 3, May-Jun. 1997.
- Neurometer® CPT, Clinical Applications. Neurotron , Inc. website: www.neurotron.com/CLINAPS.html, last accessed Oct. 23, 2006.
- NEUROMETER® CPT, Frequently Asked Questions. Neurotron , Inc. website: www.neurotron.com/CPTFAQ/html, last accessed Oct. 23, 2006.
- NEUROMETER® CPT, Products Page. Neurotron , Inc. website: www.neurotron.com/products.html, last accessed Oct. 23, 2006.
- NEUROMETER® Electrodiagnostic Neuroselective Sensory Nerve Evaluation: Charts, Tables, Documents & Downloads. Neurotron , Inc. website: www.neurotron.com/downloads.html, last accessed Oct. 23, 2006.
- Odd, De et al, Does Radio-opaque Contrast Improve Radiographic localisation of Percutaneous Central Venous Lines?, *Arch Dis Child Fetal Neonatal Ed*, pp. 41-43, vol. 89 No. 1, Jan. 2004.
- Palesty, JA et al, Routine Chest Radiographs Following Central Venous Recatheterization over a Wire are not Justified, *Am J Surg*, pp. 618-621, vol. 176 No. 6, Dec. 1998.
- Paliotti, Roberta P. et al, Intravascular Doppler Technique for Monitoring Renal Venous Blood Flow in Man, *JNephrol*, pp. 57-62, 2003.
- Parker, K.H. et al, Cardiovascular Fluid Dynamics, Department of Bioengineering, National Heart and Lung Institute, Imperial College of Science, Technology and Medicine, Cardiovascular Haemodynamics, pp. 1-28, Sep. 26, 2005.
- Pawlik, et al., "Central Venous Catheter Placement: Comparison of the Intravascular Guidewire and the Fluid Column Electrocardiograms." *European Journal of Anaesthesiology*, vol. 41, pp. 594-599, 2004.
- PCT/US13/62409 filed Sep. 27, 2013 International Search Report and Written Opinion dated Feb. 24, 2014.
- PCT/US2006/033079 filed Aug. 24, 2006 International Preliminary Report on Patentability dated Feb. 26, 2008.
- PCT/US2006/033079 filed Aug. 24, 2006 Search Report dated Dec. 19, 2006.
- PCT/US2006/033079 filed Aug. 24, 2006 Written Opinion dated Dec. 19, 2006.
- PCT/US2008/060502 filed Apr. 16, 2008 International Search Report and Written Opinion dated Oct. 16, 2008.
- PCT/US2008/084751 filed Nov. 25, 2008 International Preliminary Report on Patentability dated Jun. 1, 2010.
- PCT/US2008/084751 filed Nov. 25, 2008 Search Report dated May 20, 2009.
- PCT/US2008/084751 filed Nov. 25, 2008 Written Opinion dated May 20, 2009.
- PCT/US2009/033116 filed Feb. 4, 2009 International Preliminary Report on Patentability dated Aug. 10, 2010.
- PCT/US2009/033116 filed Feb. 4, 2009 Search Report dated Mar. 13, 2009.
- PCT/US2009/033116 filed Feb. 4, 2009 Written Opinion dated Mar. 13, 2009.
- PCT/US2009/041051 filed Apr. 17, 2009 International Preliminary Report on Patentability dated Apr. 8, 2014.
- PCT/US2009/041051 filed Apr. 17, 2009 Search Report dated Jul. 28, 2009.
- PCT/US2009/041051 filed Apr. 17, 2009 Written Opinion dated Jul. 28, 2009.
- PCT/US2009/054687 filed Aug. 21, 2009 International Preliminary Report on Patentability dated Feb. 22, 2011.
- PCT/US2009/054687 filed Aug. 21, 2009 Search Report dated Oct. 6, 2009.
- PCT/US2009/054687 filed Aug. 21, 2009 Written Opinion dated Oct. 6, 2009.
- PCT/US2009/056567 filed Sep. 10, 2009 International Preliminary Report on Patentability dated Mar. 15, 2011.
- PCT/US2009/056567 filed Sep. 10, 2009 Search Report dated Nov. 6, 2009.
- PCT/US2009/056567 filed Sep. 10, 2009 Written Opinion dated Nov. 6, 2009.
- PCT/US2010/038555 filed Jun. 14, 2010 Search Report dated Oct. 5, 2010.
- PCT/US2010/038555 filed Jun. 14, 2010 Written Opinion dated Oct. 5, 2010.
- PCT/US2010/045084 filed Aug. 10, 2010 International Preliminary Report on Patentability dated Feb. 23, 2012.
- PCT/US2010/045084 filed Aug. 10, 2010 Search Report dated Apr. 14, 2011.
- PCT/US2010/045084 filed Aug. 10, 2010 Written Opinion dated Apr. 14, 2011.
- PCT/US2010/050773 filed Sep. 29, 2010 Search Report dated Jan. 24, 2011.
- PCT/US2010/050773 filed Sep. 29, 2010 Written Opinion dated Jan. 24, 2011.
- PCT/US2010/051917 filed Oct. 8, 2010 Search Report dated Nov. 29, 2010.

(56)

References Cited

OTHER PUBLICATIONS

- PCT/US2010/051917 filed Oct. 8, 2010 Written Opinion dated Nov. 29, 2010.
- PCT/US2011/023497 filed Feb. 2, 2011 Search Report dated Jun. 6, 2011.
- PCT/US2011/023497 filed Feb. 2, 2011 Written Opinion dated Jun. 6, 2011.
- PCT/US2011/038391 filed May 27, 2011 International Preliminary Report on Patentability and Written Opinion dated Dec. 4, 2012.
- PCT/US2011/038391 filed May 27, 2011 International Search Report dated Sep. 21, 2011.
- PCT/US2011/038415 filed May 27, 2011 International Preliminary Report on Patentability dated Dec. 13, 2012.
- PCT/US2011/038415 filed May 27, 2011 International Search Report dated Sep. 28, 2011.
- PCT/US2011/038415 filed May 27, 2011 Written Opinion dated Sep. 28, 2011.
- PCT/US2011/047127 filed Aug. 9, 2011 International Preliminary Report on Patentability dated Apr. 18, 2013.
- PCT/US2011/047127 filed Aug. 9, 2011 International Search Report dated Feb. 29, 2012.
- PCT/US2011/047127 filed Aug. 9, 2011 Written Opinion dated Feb. 29, 2012.
- PCT/US2011/048403 filed Aug. 19, 2011 International Preliminary Report on Patentability dated Jul. 30, 2013.
- PCT/US2011/048403 filed Aug. 19, 2011 International Search Report dated Dec. 15, 2011.
- PCT/US2011/048403 filed Aug. 19, 2011 Written Opinion dated Dec. 15, 2011.
- CN 200980144663.8 filed May 9, 2011 Fifth Office Action dated May 26, 2015.
- CN 200980144663.8 filed May 9, 2011 Fourth Office Action dated Nov. 15, 2014.
- CN 201080035659.0 filed Feb. 10, 2012 Second Office Action dated Oct. 9, 2014.
- CN 201080035659.0 filed Feb. 10, 2012 Third Office Action dated Mar. 19, 2015.
- CN 201080053838.7 filed May 28, 2012 Fourth Office Action dated Jun. 2, 2015.
- CN 201080053838.7 filed May 28, 2012 Third Office Action dated Dec. 4, 2014.
- CN 201180016462.7 filed Sep. 27, 2012 Second Office Action dated Dec. 9, 2014.
- CN 201180016462.7 filed Sep. 27, 2012 Third Office Action dated Jun. 10, 2015.
- CN 201180037065.8 filed Jan. 28, 2013 First Office Action dated Jun. 2, 2015.
- CN 201180037065.8 filed Jan. 28, 2013 First Office Action dated Sep. 28, 2014.
- CN 201180037068.1 filed Jan. 28, 2013 First Office Action dated Apr. 20, 2015.
- CN 201180037068.1 filed Jan. 28, 2013 First Office Action dated Sep. 9, 2014.
- CN 201180040151.4 filed Feb. 19, 2013 First Office Action dated Oct. 28, 2014.
- CN 201180040151.4 filed Feb. 19, 2013 Second Office Action dated Jun. 19, 2015.
- CN 201180043512.0 filed Mar. 8, 2013 First Office Action dated Jul. 31, 2014.
- CN 201180043512.0 filed Mar. 8, 2013 Second Office Action dated Apr. 14, 2015.
- CN 201180052587.5 filed Apr. 28, 2013 First Office Action dated Jan. 26, 2015.
- CN 201180068309.9 filed Aug. 22, 2013 First Office Action dated Oct. 16, 2014.
- CN 201180068309.9 filed Aug. 22, 2013 Second Office Action dated May 6, 2015.
- EP 11 818 828.3 filed Mar. 18, 2013 Extended European Search Report dated Dec. 10, 2014.
- EP 11787515.3 filed Dec. 12, 2012 partial European search report dated Jun. 23, 2015.
- EP 11787527.8 filed Dec. 19, 2012 partial European search report dated May 26, 2015.
- EP 11837113.7 filed May 28, 2013 Extended European Search Report dated Apr. 24, 2014.
- EP 12177438.4 filed Jul. 23, 2012 European Search Report dated Jun. 7, 2015.
- EP 12177438.4 filed Jul. 23, 2012 Examination Report dated Dec. 5, 2014.
- EP 12807886.2 filed Jan. 15, 2014 Extended European Search Report dated Feb. 6, 2015.
- EP14197136.6 filed Dec. 10, 2014 Extended European Search Report dated May 26, 2015.
- JP 2012-515222 filed Dec. 9, 2011 Office Action dated Feb. 23, 2015.
- JP 2012-552060 filed Aug. 1, 2012 Office Action dated Nov. 12, 2014.
- JP 2013-512046 filed Nov. 26, 2012 First Office Action dated Mar. 23, 2015.
- JP 2013-512051 filed Nov. 26, 2012 First Office Action dated Mar. 23, 2015.
- JP 2013-524999 filed Jan. 22, 2013 First Office Action dated Jun. 1, 2015.
- Moureau, Nancy L. et al., "Electrocardiogram (EKG) Guided Peripherally Inserted Central Catheter Placement and Tip Position: Results of a Trial to Replace Radiological Confirmation," Journal of the Association for Vascular Access, pp. 8-14, vol. 15, No. 1, 2010.
- MX/a/2012/013858 filed Nov. 28, 2012 First Office Action dated Sep. 26, 2014.
- MX/a/2012/013858 filed Nov. 28, 2012 Second Office Action dated Jun. 10, 2015.
- Pittiruti, et al., "The intracavitary ECG method for positioning the tip of central venous catheters: results of an Italian multicenter study," J Vasc Access, pp. 1-9, Nov. 21, 2011.
- Pittiruti, et al. "The electrocardiographic method for positioning the tip of central venous catheters" Java, pp. 1-12, Feb. 12, 2011.
- RU 2011150917 filed Dec. 15, 2011 Second Office Action dated Aug. 28, 2014.
- U.S. Appl. No. 1/118,033, filed May 27, 2011 Non-Final Office Action dated Jul. 8, 2015.
- U.S. Appl. No. 12/426,175, filed Apr. 17, 2009 Examiner's Answer dated Oct. 7, 2014.
- U.S. Appl. No. 12/545,762, filed Aug. 21, 2009 Non-Final Office Action dated Nov. 7, 2014.
- U.S. Appl. No. 12/815,331, filed Jun. 14, 2010 Advisory Action dated Mar. 5, 2015.
- U.S. Appl. No. 12/815,331, filed Jun. 14, 2010 Final Office Action dated Dec. 23, 2014.
- U.S. Appl. No. 12/815,331, filed Jun. 14, 2010 Non-Final Office Action dated Jun. 1, 2015.
- U.S. Appl. No. 12/854,083, filed Aug. 10, 2010 Non-Final Office Action dated Mar. 16, 2015.
- U.S. Appl. No. 12/893,916, filed Sep. 29, 2010 Final Office Action dated Jan. 15, 2015.
- U.S. Appl. No. 12/893,916, filed Sep. 29, 2010 Non-Final Office Action dated Sep. 25, 2014.
- U.S. Appl. No. 13/019,939, filed Feb. 2, 2011 Non-Final Office Action dated Feb. 9, 2015.
- U.S. Appl. No. 13/118,033, filed May 27, 2011 Non-Final Office Action dated Feb. 3, 2015.
- U.S. Appl. No. 13/118,138, filed May 27, 2011 Non-Final Office Action dated Jul. 15, 2015.
- "Ascension to Launch New 3D Guidance™ Tracker at TCT 2006." Press Releases from Ascension website: www.ascension-tech.com/news/press_101106.php, last accessed Dec. 1, 2006.
- Acuson—The Value of Vision, AcuNav Diagnostic Ultrasound Catheter, 2000.
- Advertising flyer for GAVECELT—The Italian Group for Long Term Venous Access Devices, for program on International Meeting on PICC's, Midline Catheters and Long Term Venous Access Devices in Catholic University, Rome, Italy on Dec. 3, 4, 5, 2008.

(56)

References Cited

OTHER PUBLICATIONS

- Alexander, GD et al, The Role of Nitrous Oxide in Postoperative Nausea and Vomiting, Collection of Abstracts Presented at the International Anesthesia Research Society by various speakers, 58th Congress, Mar. 12-14, 1984, Anesthesia and Analgesia, pp. 175-284, vol. 63, 1984.
- Allan, P.L. et al, Role of Ultrasound in the Assessment of Chronic Venous Insufficiency, Ultrasound Quarterly, vol. 17, No. 1, pp. 3-10, 2001.
- Andropoulos, et al. "A Controlled Study of the Transesophageal Echocardiography to Guide Central Venous Catheter Placement in Congenital Heart Surgery Patients." The International Anesthesia Research Society, vol. 89, pp. 65-70, 1999.
- Anonymous author, Correct Catheter Placement with a low-impact, reliable and economical method, <<http://www.cvc-partner.com/index.cfm?103A955CC6844BF58ACFE3C9C1471959>>, last accessed Dec. 22, 2011.
- Arai, J et al, Detection of Peripherally Inserted Central Catheter Occlusion by in-line Pressure Monitoring, Paediatr Anaesth, pp. 621-624, vol. 12 No. 7, Sep. 2002.
- Arrow International, Inc., The Arrow-Johans RAECG Adapter-Making Proper Central Venous Catheter Placement More Reliable (Modle No. EG-04900), Technical Report 1987, USA.
- Aslamy, et al. "MRI of Central Venous Anatomy: Implications for Central Venous Catheter Insertion." American College of Chest Physicians, Jun. 8, 2009.
- AU 2006283022 filed Aug. 24, 2006 Office Action dated Dec. 22, 2010.
- AU 2008329807 exam requested Aug. 13, 2012 Examination Report No. 1 dated Feb. 15, 2013.
- AU 2008329807 exam requested Aug. 13, 2012 Notice of Acceptance dated Feb. 14, 2014.
- AU 2010300677 filed Mar. 12, 2012 First Examination Report dated Mar. 9, 2014.
- AU 2011289513 filed Jan. 21, 2013 Examiner's Report dated Jul. 5, 2013.
- AU 2012202293 filed Apr. 19, 2012 Examination Report No. 1 dated Apr. 24, 2013.
- AU 2013201648 filed Mar. 19, 2013 Examiner's Report dated Mar. 5, 2014.
- AU 2013201648 filed Mar. 19, 2013 Examiner's Report dated Oct. 14, 2013.
- AU 2013202824 filed Apr. 6, 2013 First Examiner's Report dated Mar. 10, 2014.
- AU 2013204243 filed Apr. 12, 2013 Examiner's Report dated Jun. 5, 2013.
- AURORA® System Technical Specifications, Oct. 2003.
- B. Braun Website, "The Optimal Position of the Central Venous Catheter." <http://www.cvcpartner.com/index.cfm?18F1BDEA1310466194960A39F4E90968> (2009).
- B. Braun, Certofix Central Venous Catheter for Placement Using the Seldinger Technique with Simultaneous ECG Lead Option, Feb. 2010.
- Bailey, SH et al, Is Immediate Chest Radiograph Necessary after Central Venous Catheter Placement in a Surgical Intensive Care Unit?, Am J Surg, pp. 517-522, vol. 180 No. 6, Dec. 2000.
- Bankier, Alexander A., Azygos Arch Cannulation by Central Venous Catheters: Radiographic Detection of Malposition and Subsequent Complications, Journal of Thoracic Imaging 12:64-69 (1997).
- Barber, JM et al, A Nurse led Peripherally Inserted Central Catheter Line Insertion Service is Effective with Radiological Support, Clin Radiol, pp. 352-354, vol. 57 No. 5, May 2002.
- Bard Access Systems, Sherlock Tip Location System, 5 pages, 2006.
- Bard Access Systems, Site Rite Vascular Access Ultrasound System, 4 pages, 2005.
- Benchimol, Alberto at al, Right Atrium and Superior Vena Cava Flow Velocity in Man Measured with the Doppler-Catheter Flowmeter-Telemetry System, The Amer Journal of Medicine, pp. 303-309, vol. 48, Mar. 1970.
- Benzadon, M. N. et al: "Comparison of the Amplitude of the P-Wave from Intracardiac Electrocardiogram Obtained by Means of a Central Venous Catheter Filled With Saline Solution to That Obtained Via Esophageal Electrocardiogram", American Journal of Cardiology, Canners Publishing Co., Newton, MA, US, vol. 98, No. 7, Oct. 1, 2006 (Oct. 1, 2006), pp. 978-981.
- BioAdvance Lumen Vu, Greenhouse Fund Feb. 2004 Recipient, www.bioadvance.com <<http://www.bioadvance.com>>, 2005.
- Borgobello, Bridget, App allows users to view electrocardiograms on smartphones dated Oct. 15, 2010; printed from <http://www.gizmag.com/app-to-view-electrocardiograms-on-smartphones/16664/> on Feb. 4, 2011.
- Buehrle, Douglas, PICC Placement in Humans using Electromagnetic Detection, <http://www.corpakmedsystems.com/supplement_material/supplementpages/navigator/navarticle.html>, 2008.
- C.R. Bard, CathTrack™ Catheter Location System at www.bardaccess.com <<http://www.bardaccess.com>>, last accessed Apr. 28, 2011.
- C.R. Bard, Inc., Bard Electrophysiology Product Catalogue, Bard Catheters, pp. 74-75 (2002), USA.
- CA 2,619,909 filed Aug. 24, 2006 Examiner's Report dated Oct. 26, 2012.
- Cadman, A et al, To Clot or Not to Clot? That is the question in Central Venous Catheters, Clinical Radiology, pp. 349-355, vol. 59 No. 4, Apr. 2004.
- Calvert, N et al, The Effectiveness and Cost-effectiveness of Ultrasound Locating Devices for Central Venous Access: A Systematic Review and Economic Evaluation, Health Technology Assessment, vol. 7, No. 12, 2003.
- Cardella, John F. et al., Intervental Radiologic Placement of Peripherally Inserted Central Catheters, Journal of Vascular and Interventional Radiology 1993; 4:653-660.
- Carlon, R et al, Secondary Migration of a Central Venous Catheter—A Case Report, Minerva Anestesiol, pp. 927-931, vol. 69 No. 12, Dec. 2003.
- Caruso, LJ et al, A Better Landmark for Positioning a Central Venous Catheter, J Clinical Monitoring and Computing, pp. 331-334, vol. 17 No. 6, Aug. 2002.
- Cavatorta, et al., "Central Venous Catheter Placement in Hemodialysis: Evaluation of Electrocardiography Using a Guidewire." The Journal of Vascular Access, vol. 2, pp. 45-50, 2001.
- Chalkiadis, GA et al, Depth of Central Venous Catheter Insertion in Adults: An Audit and Assessment of a Technique to Improve Tip Position, Anaesth Intensive Care, pp. 61-66, vol. 26 No. 1, Feb. 1998.
- Chamsi-Pasha, Hassan et al, Cardiac Complications of Total Parenteral Nutrition: The Role of Two-Dimensional Echocardiography in Diagnosis, Annals of the Royal College of Surgeons of England, pp. 120-123, vol. 71, 1989.
- Chang, Thomas C. et al., Are Routine Ch Ladiographs Necessary After Image-Guided Placement of Internal Jugular Central Venous Access Devices?, AJR Feb. 1998;170:335-337.
- Chaturvedi et al., "Catheter Malplacement During Central Venous Cannulation Through Arm Veins in Pediatric Patients." Journal of Neurosurgical Anesthesiology, vol. 15, No. 3 pp. 170-175, Jan. 2003.
- Chen, Zhongping et al, Optical Doppler Tomography: Imaging in vivo Blood Flow Dynamics Following Pharmacological Intervention and Photodynamic Therapy, 7 pages, vol. 67, Photochemistry and Photobiology, 1998.
- Cheng, KI et al, A Novel Approach of Intravenous Electrocardiograph Technique in Correct Position the Long-Term Central Venous Catheter, Kaohsiung J Med Sci, pp. 241-247, vol. 16 No. 5, May 2000 (Abstract only).
- Cheung, P., et al., The Effect of a Disposable Probe Cover on Pulse Oximetry, Anaesth Intensive Care 2002; 30: 211-214.
- Chu, et al., "Accurate Central Venous Port-A Catheter Placement: Intravenous Electrocardiography and Surface Landmark Techniques Compared by Using Transesophageal Echocardiography." The International Anesthesia Research Society, vol. 98, pp. 910-914, 2004.

(56)

References Cited

OTHER PUBLICATIONS

- CA 2,721,715 filed Apr. 17, 2009 Examiner's Report dated Aug. 18, 2015.
- CN 201180052587.5 filed Apr. 28, 2013 Second Office Action dated Aug. 19, 2015.
- CN 201180068309.9 filed Aug. 22, 2013 Third Office Action dated Sep. 2, 2015.
- EP 10821193.9 filed Mar. 27, 2012 Partial European Search Report dated Oct. 9, 2015.
- EP 11787515.3 filed Dec. 12, 2012 partial European search report dated Oct. 27, 2015.
- EP 11787527.8 filed Dec. 19, 2012 Extended European Search Report dated Oct. 9, 2015.
- MX/a/2012/013672 filed Nov. 23, 2012 First Office Action dated Aug. 10, 2015.
- U.S. Appl. No. 12/545,762, filed Aug. 21, 2009 Non-Final Office Action dated Sep. 11, 2015.
- U.S. Appl. No. 12/854,083, filed Aug. 10, 2010 Final Office Action dated Aug. 21, 2015.
- U.S. Appl. No. 12/893,916, filed Sep. 29, 2010 Non-Final Office Action dated Sep. 10, 2015.
- U.S. Appl. No. 13/240,171, filed Sep. 22, 2011 Advisory Action dated Aug. 18, 2015.
- U.S. Appl. No. 13/469,932, filed May 11, 2012 Non-Final Office Action dated Sep. 4, 2015.
- U.S. Appl. No. 13/665,420, filed Oct. 31, 2012 Non-Final Office Action dated Jul. 9, 2015.
- U.S. Appl. No. 13/890,158, filed May 8, 2013 Non-Final Office Action dated Jul. 9, 2015.
- U.S. Appl. No. 14/270,241, filed May 5, 2014 Notice of Allowance dated Oct. 7, 2015.
- U.S. Appl. No. 14/309,511, filed Jun. 19, 2014 Non-Final Office Action, dated Sep. 24, 2015.
- U.S. Appl. No. 14/317,501, filed Jun. 27, 2014 Advisory Action dated Sep. 16, 2015.
- U.S. Appl. No. 14/506,552, filed Oct. 3, 2014 Non-Final Office Action dated Oct. 1, 2015.
- CN 201180037068.1 filed Jan. 28, 2013 Third Office Action dated Oct. 19, 2015.
- CN 201180040151.4 filed Feb. 19, 2013 Third Office Action dated Dec. 10, 2015.
- JP 2012-552060 filed Aug. 1, 2012 Second Office Action dated Nov. 6, 2015.
- JP 2013-512046 filed Nov. 26, 2012 Decision of Rejection dated Dec. 8, 2015.
- U.S. Appl. No. 12/815,331, filed Jun. 14, 2010 Final Office Action dated Nov. 4, 2015.
- U.S. Appl. No. 13/240,171, filed Sep. 22, 2011 Non-Final Office Action dated Dec. 1, 2015.
- U.S. Appl. No. 14/141,046, filed Dec. 26, 2013 Non-Final Office Action dated Nov. 5, 2015.
- U.S. Appl. No. 14/201,300, filed Mar. 7, 2014 Non-Final Office Action dated Jan. 6, 2016.
- U.S. Appl. No. 14/449,061, filed Jul. 31, 2014 Final Office Action dated Nov. 6, 2015.
- PCT/US2011/052793 filed Sep. 22, 2011 International Preliminary Report on Patentability dated Apr. 4, 2013.
- PCT/US2011/052793 filed Sep. 22, 2011 International Search Report dated Jan. 6, 2012.
- PCT/US2011/052793 filed Sep. 22, 2011 Written Opinion dated Jan. 6, 2012.
- PCT/US2011/058138 filed Oct. 27, 2011 International Preliminary Report on Patentability dated May 10, 2013.
- PCT/US2011/058138 filed Oct. 27, 2011 International Search Report dated Feb. 7, 2012.
- PCT/US2011/058138 filed Oct. 27, 2011 Written Opinion dated Feb. 7, 2012.
- PCT/US2011/067268 filed Dec. 23, 2011 International Preliminary Report on Patentability dated Jul. 4, 2013.
- PCT/US2011/067268 filed Dec. 23, 2011 International Search Report and Written Opinion dated Apr. 27, 2012.
- PCT/US2012/045814 filed Jul. 6, 2012 International Search Report and Written Opinion dated Oct. 1, 2012.
- PCT/US2013/065121 filed Oct. 15, 2013 International Search Report and Written Opinion dated Jan. 16, 2014.
- PCT/US2014/022019 filed Mar. 7, 2014 International Search Report and Written Opinion dated Jun. 11, 2014.
- Pennington, C.R., Right Atrial Thrombus: a Complication of Total Parenteral Nutrition, *British Medical Journal*, pp. 446-447, vol. 295, Aug. 15, 1987.
- Petersen, J et al, Silicone Venous Access Devices Positioned with their Tip High in the Superior Vena Cava are More Likely to Malfunction, *Am J Surg*, pp. 38-41, vol. 178 No. 1, Jul. 1999.
- Pittiruti, et al, Intracavitary EKG Monitoring: A reliable method for controlling tip position during and after PICC Insertion presentation in Catholic University, Rome, Italy in 2008.
- Pittiruti, et al. "The EKG Method for Positioning the Tip of PICCs: Results from Two Preliminary Studies." *JAVA*, vol. 13, No. 4, pp. 179-185, 2008.
- Polos, PG et al, Tips for Monitoring the Position of a Central Venous Catheter—How Placement can go awry—even when the anatomy is normal, *J Crit Illn*, pp. 660-674, vol. 8 No. 6, Jun. 1993 (Abstract only).
- Pop, Gheorghe A. et al., Catheter-based impedance measurements in the right atrium for continuously monitoring hematocrit and estimating blood viscosity changes; an in vivo feasibility study in swine, *Biosensors and Bioelectronics* 19 (2004) 1685-1693.
- Popp, M. B. et al., Accuracy of implanted port placement with the use of the electromagnetic CathTrack® catheter locator system, *The Journal of Vascular Access* 2005; 6: 9-12.
- Randolph AG et al, Ultrasound guidance for placement of central venous catheters: a meta-analysis of the literature, *Critical Care Medicine*, pp. 2053-2058, vol. 24, Dec. 1996.
- Reece, A et al, Positioning Long Lines: Contrast Versus Plain Radiography, *Arch Dis Child Fetal Neonatal Ed*, pp. 129-130, vol. 84 No. 2, Mar. 2001.
- Reynolds, N et al, Assessment of Distal Tip Position of Long Term Central Venous Feeding Catheters using Transesophageal Echocardiography, *JPEN J Parenter Enteral Nutr*, pp. 39-41, vol. 25 No. 1, Jan.-Feb. 2001.
- RU 2011150917 filed Dec. 15, 2011 First Office Action dated Apr. 24, 2014.
- Ruschulte, Heiner et al, Prevention of Central Venous Catheter related infections with chlorhexidine gluconate impregnated wound dressings: A randomized controlled trial, presented as an abstract at the Annual meeting of the European Society of Anaesthesiologists (ESA) in Madrid, Spain in Jun. 2006, 12 pages, *Annals of Hematology*, Jul. 14, 2008.
- Rutherford, J. S. et al., Depth of Central Venous Catheterization: An Audit of Practice in a Cardiac Surgical Unit, *Anaesth Intens Care* 1994; 22: 267-271.
- Sacolick, et al. "Electromagnetically Tracked Placement of a Peripherally Inserted Central Catheter." *SPIE Medical Imaging*, 2004 Proceedings.
- Salem, et al. "A New Peripherally Implanted Subcutaneous Permanent Central Venous Access Device for Patients Requiring Chemotherapy." *Journal of Clinical Oncology*, vol. 11, No. 11, pp. 2181-2185, Nov. 1993.
- Savary, D et al, Intra-atrial Monitoring to Add Insertion of a Central Venous Line in Pre-Hospital Emergency Care *Journal Europeen des Urgences*, pp. 75-78, vol. 17 No. 2, 2004.
- Schafer et al. "Incorrect placement of a vena cava catheter and its prevention by intra-atrial ECG." *Anaesthetist*. Jan. 1988;37(1):49-51.
- Schummer, et al. "Central Venous Catheters—The inability of 'intra-atrial ECG' to prove adequate positioning." *British Journal of Anaesthesia*, vol. 93, No. 2, pp. 193-198, 2004.
- Schummer, W et al, ECG-guided Central Venous Catheter Positioning: Does it detect the Pericardial Reflection rather than the Right Atrium?, *Eur J Anaesthesiol*, pp. 600-605, vol. 21 No. 8, Aug. 2004 (Abstract only).

(56)

References Cited

OTHER PUBLICATIONS

- Schummer, W et al, Intra-Atrial ECG is not a Reliable Method for Positioning Left Internal Jugular Vein Catheters, *Br J Anaesth*, pp. 481-486, vol. 91 No. 4, Oct. 2003.
- Schummer, W, Central Venous Catheter—the Inability of “Intra-Atrial ECG” to prove Adequate Positioning, *Br J Anaesth*, pp. 193-198, vol. 93 No. 2, Aug. 2004.
- Schuster, M. et al., The carina as a landmark in central venous catheter placement, *British Journal of Anaesthesia* 85 (2): 192-4 (2000).
- Siela, Debra, Using Chest Radiography in the Intensive Care Unit, *Crit Care Nurse* Aug. 1, 2002 vol. 22 No. 4, pp. 18-27.
- Simon, et al., “Central Venous Catheter Placement in Children: Evaluation of Electrocardiography Using J-Wire.” *Paediatric Anaesthesia* vol. 9, pp. 501-504, 1999.
- Smith, Brigham, et al., Intravenous electrocardiographic guidance for placement of peripherally inserted central catheters, *Journal of Electrocardiology* 43 (2010) 274-278.
- Stark, DD et al, Radiographic Assessment of Venous Catheter Position in Children: Value of the Lateral View, *Pediatric Radiology*, pp. 76-80, vol. 14 No. 2, 1984.
- Starkhammar et al. “Cath-Finder Catheter Tracking System: A New Device for Positioning of Central Venous Catheters. Early Experience from Implantation of Brachial portal Systems.” *Acta Anaesthesiol Scandinavia*, vol. 34, No. 4 pp. 296-300, May 1990.
- Starkhammer, H et al, Central Venous Catheter Placement using Electromagnetic Position Sensing: A Clinical Evaluation, *Biomed. Instrum Technol*, vol. 30 No. 2, pp. 164-170; Mar.-Apr. 1996.
- Starr, David S et al, EKG Guided Placement of Subclavian CVP Catheters Using J-Wire, pp. 673-676, *Ann. Surg.*, Dec. 1986.
- Stas, M et al, Peroperative Intravasal Electrographic Control of Catheter Tip Position in Access Ports Placed by Venous Cut-Down Technique, *EJSO*, pp. 316-320, vol. 27, 2001.
- Stereotaxis Magetic Navigation System with Navigant™ User Interface, 2005 Brochure.
- Stereotaxis, Expanding the Possibilities of Interventional Medicine: Remote Navigation and Automation, pp. 1-8, Apr. 2011.
- Tepa® Health Innovation PC based ECG System Introduction and Technical Specifications, EKG Master USB, 2 pages, Nov. 2003.
- The FloWire Doppler Guide Wire located <<http://www.volcanocorp.com/products/flowire-doppler-guide-wire.php>>, 2011.
- Traxal Technologies, Tracking Technology website overview: www.traxal.com/rd/rd_classroom_trackingtechnology.htm, last accessed Dec. 1, 2006.
- UAB Health Systems, Arrhythmias, retrieved from <http://www.health.uab.edu/14564/> on Nov. 15, 2007, 12 pages.
- U.S. Appl. No. 11/466,602, filed Aug. 23, 2006 Advisory Action dated Jun. 22, 2009.
- U.S. Appl. No. 11/466,602, filed Aug. 23, 2006 Appeal Board Decision dated Sep. 17, 2012.
- U.S. Appl. No. 11/466,602, filed Aug. 23, 2006 Final Office Action dated Apr. 8, 2010.
- U.S. Appl. No. 13/118,138, filed May 27, 2011 Non-Final Office Action dated Oct. 9, 2014.
- U.S. Appl. No. 13/240,171, filed Sep. 22, 2011 Final Office Action dated Jun. 10, 2015.
- U.S. Appl. No. 13/240,171, filed Sep. 22, 2011 Non-Final Office Action dated Dec. 26, 2014.
- U.S. Appl. No. 13/283,395, filed Oct. 27, 2011 Advisory Action dated Jan. 28, 2014.
- U.S. Appl. No. 13/283,395, filed Oct. 27, 2011 Final Office Action dated Nov. 14, 2013.
- U.S. Appl. No. 13/336,919, filed Dec. 23, 2011 Final Office Action dated Dec. 19, 2014.
- U.S. Appl. No. 13/336,919, filed Dec. 23, 2011 Non-Final Office Action dated Jul. 9, 2015.
- U.S. Appl. No. 13/665,420, filed Oct. 31, 2012 Non-Final Office Action dated Oct. 9, 2014.
- U.S. Appl. No. 13/887,166, filed May 3, 2013 Examiner’s Answer dated Jul. 16, 2015.
- U.S. Appl. No. 14/141,046, filed Dec. 26, 2013 Non-Final Office Action dated Feb. 11, 2015.
- U.S. Appl. No. 14/270,241, filed May 5, 2014 Non-Final Office Action dated Apr. 23, 2015.
- U.S. Appl. No. 14/317,501, filed Jun. 27, 2014 Final Office Action dated Jul. 1, 2015.
- U.S. Appl. No. 14/317,501, filed Jun. 27, 2014 Non-Final Office Action dated Mar. 3, 2015.
- U.S. Appl. No. 14/449,061, filed Jul. 31, 2014 Non-Final Office Action dated Apr. 27, 2015.
- U.S. Appl. No. 14/548,151, filed Nov. 19, 2014 Non-Final Office Action dated Jun. 5, 2015.
- CN 200880012117.4 filed Apr. 16, 2008 Fourth Office Action dated Sep. 4, 2013.
- CN 201180037065.8 filed Jan. 28, 2013 Third Office Action dated Nov. 24, 2015.
- CN 2011800525875 filed Apr. 28, 2013 Office Action dated Feb. 24, 2016.
- CN 201280033189.3 filed Jan. 3, 2014 First Office Action dated Apr. 3, 2014.
- CN 201280033189.3 filed Jan. 3, 2014 Second Office Action dated Sep. 14, 2015.
- CN 201410009216.4 filed Jan. 8, 2014 Second Office Action dated Sep. 25, 2015.
- EP 09743249.6 filed Oct. 18, 2010 Extended European Search Report dated Jan. 13, 2016.
- EP 11740309.7 filed Aug. 23, 2012 Extended European Search Report dated Aug. 3, 2015.
- EP 15179061.5 filed Jul. 30, 2015 Extended European Search Report dated Jan. 14, 2016.
- JP 2010-504220 filed Sep. 3, 2009 Office Action dated Apr. 1, 2014.
- JP 2010-504220 filed Sep. 3, 2009 Office Action dated Apr. 18, 2013.
- JP2013-530322 filed Mar. 18, 2013, First Office Action dated Jul. 31, 2015.
- MX/a/2013/001317 filed Jan. 31, 2013 First Office Action dated Nov. 26, 2015.
- U.S. Appl. No. 12/369,625, filed Feb. 11, 2009 Notice of Panel Decision dated Aug. 1, 2012.
- U.S. Appl. No. 12/545,762, filed Aug. 21, 2009 Non-Final Office Action dated Feb. 16, 2016.
- U.S. Appl. No. 12/854,083, filed Aug. 10, 2010 Non-Final Office Action dated Feb. 1, 2016.
- U.S. Appl. No. 12/893,916, filed Sep. 29, 2010 Final Office Action dated Mar. 25, 2016.
- U.S. Appl. No. 13/118,033, filed May 27, 2011 Final Office Action dated Apr. 1, 2016.
- U.S. Appl. No. 13/118,138, filed May 27, 2011 Final Office Action dated Apr. 1, 2016.
- U.S. Appl. No. 13/240,171, filed Sep. 22, 2011 Final Office Action dated May 6, 2016.
- U.S. Appl. No. 13/337,987, filed Dec. 27, 2011 Examiner’s Answer dated Jul. 2, 2014.
- U.S. Appl. No. 13/337,987, filed Dec. 27, 2011 Final Office Action dated Sep. 19, 2013.
- U.S. Appl. No. 13/469,932, filed May 11, 2012 Final Office Action dated Apr. 7, 2016.
- U.S. Appl. No. 13/665,420, filed Oct. 31, 2012 Final Office Action dated Apr. 8, 2016.
- U.S. Appl. No. 14/040,205, filed Sep. 27, 2013 Non-Final Office Action dated Mar. 10, 2016.
- U.S. Appl. No. 14/201,300, filed Mar. 7, 2014 Final Office Action dated May 5, 2016.
- U.S. Appl. No. 14/449,061, filed Jul. 31, 2014 Notice of Allowance dated Apr. 13, 2016.
- JP 2013-512046 filed Nov. 26, 2012 Office Action dated May 16, 2016.
- KR 10-2012-7000866 filed Jan. 11, 2012 First Office Action dated Jun. 16, 2016.
- RU 2013158008 filed Dec. 26, 2013 First Office Action dated May 27, 2016.
- U.S. Appl. No. 12/893,916, filed Sep. 29, 2010 Advisory Action dated Jun. 2, 2016.

(56)

References Cited

OTHER PUBLICATIONS

U.S. Appl. No. 13/240,171, filed Sep. 22, 2011 Advisory Action dated Jul. 22, 2016.
U.S. Appl. No. 13/336,919, filed Dec. 23, 2011 Notice of Allowance dated Jul. 26, 2016.
U.S. Appl. No. 13/469,932, filed May 11, 2012 Advisory Action dated Jun. 27, 2016.
U.S. Appl. No. 13/890,158, filed May 8, 2013 Advisory Action dated Jul. 26, 2016.
U.S. Appl. No. 14/141,046, filed Dec. 26, 2013 Advisory Action dated Aug. 4, 2016.
U.S. Appl. No. 14/201,300, filed Mar. 7, 2014 Advisory Action dated Jul. 18, 2016.
U.S. Appl. No. 14/309,511, filed Jun. 19, 2014 Notice of Allowance, dated Jul. 26, 2016.
U.S. Appl. No. 14/317,501, filed Jun. 27, 2014 Examiner's Answer dated Jun. 30, 2016.
U.S. Appl. No. 14/548,151, filed Nov. 19, 2014 Advisory Action dated Jul. 22, 2016.
CN 201180037065.8 filed Jan. 28, 2013 Fourth Office Action dated May 5, 2016.
JP 2014-519081 filed Dec. 27, 2013 First Office Action dated Apr. 26, 2016.

JP2013-530322 filed Mar. 18, 2013, Office Action dated May 2, 2016.
U.S. Appl. No. 13/858,782, filed Apr. 8, 2013 Notice of Allowance dated Oct. 9, 2014.
U.S. Appl. No. 14/141,046, filed Dec. 26, 2013 Final Office Action dated May 11, 2016.
CN 201410009216.4 filed Jan. 8, 2014 Office Action dated Jun. 15, 2016.
AU 2012278809 filed Nov. 12, 2013 Notice of Acceptance dated Sep. 13, 2016.
CN 200980144663.8 filed May 9, 2011 Notice of Reexamination dated Aug. 5, 2016.
CN 201180037065.8 filed Jan. 28, 2013 Notice of Grant dated Aug. 30, 2016.
EP 14761249.3 Filed Sep. 3, 2015 Extended European Search Report dated Sep. 19, 2016.
U.S. Appl. No. 12/893,916 filed Sep. 29, 2010 Non-Final Office Action dated Aug. 31, 2016.
U.S. Appl. No. 14/201,300 filed Mar. 7, 2014 Non-Final Office Action dated Aug. 24, 2016.
U.S. Appl. No. 12/426,175 filed Apr. 17, 2009 Decision on Appeal dated Nov. 7, 2016.

* cited by examiner

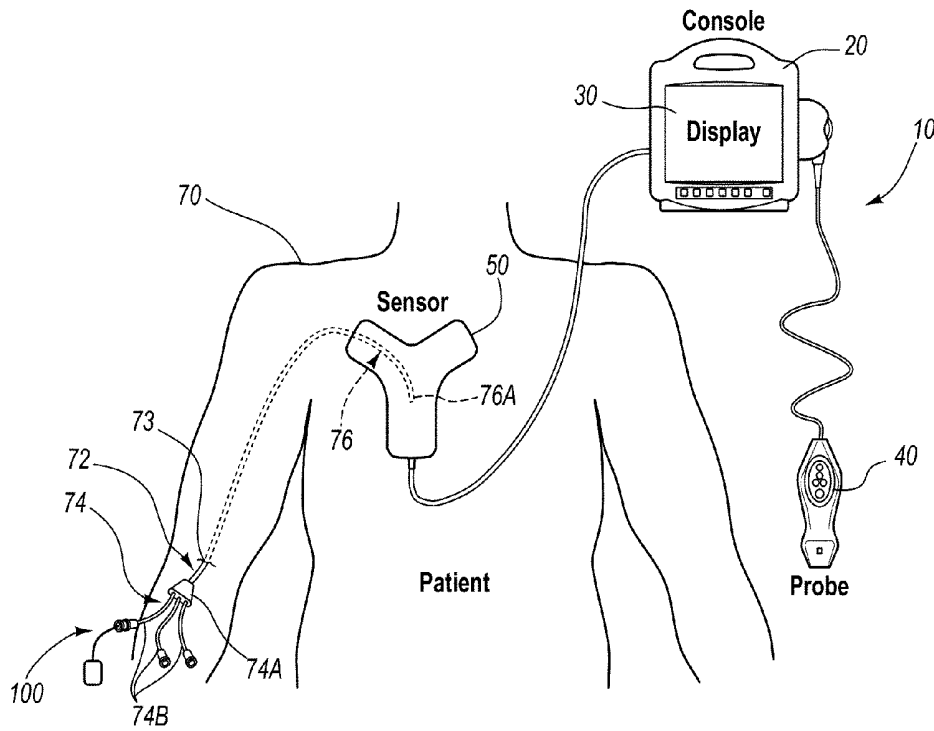
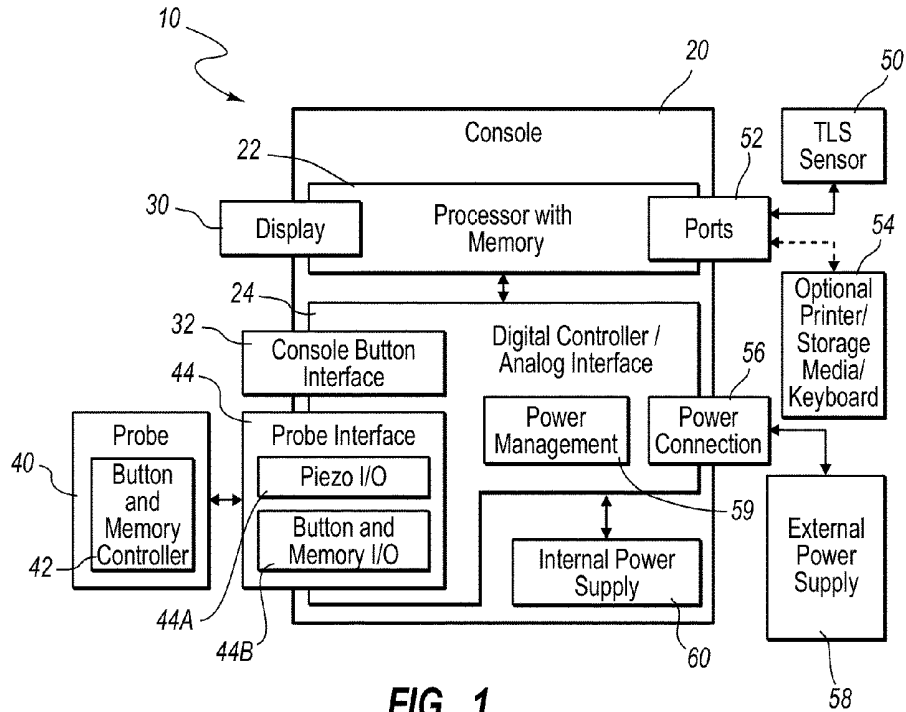

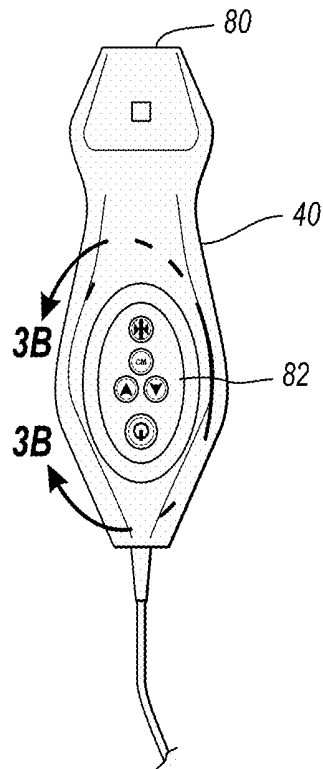

FIG. 3A

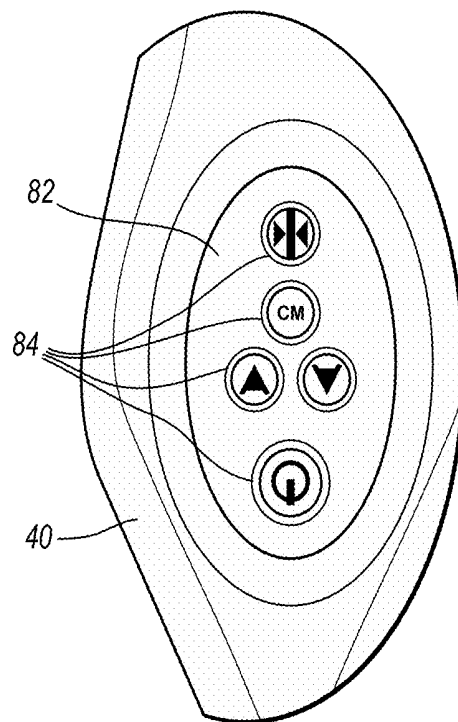

FIG. 3B

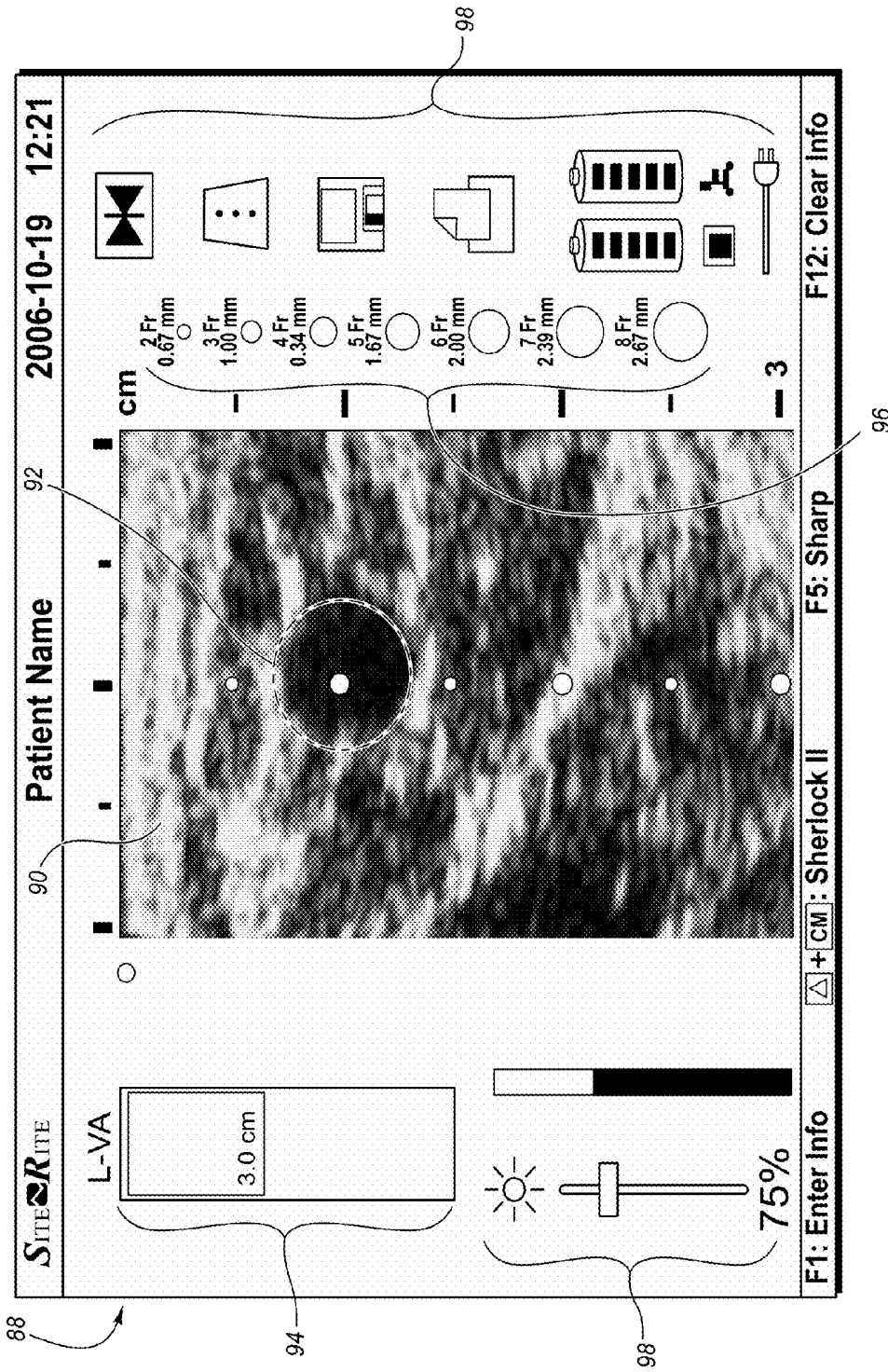

FIG. 4

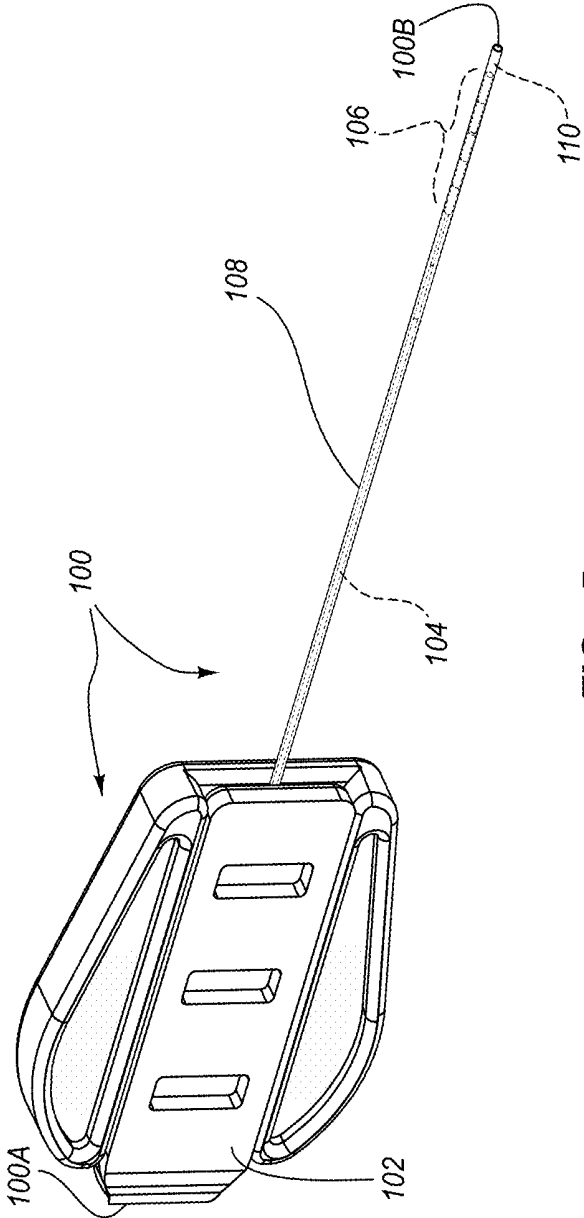

FIG. 5

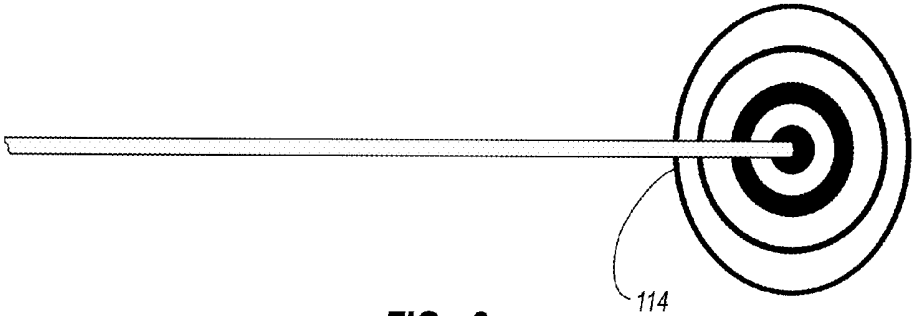

FIG. 6

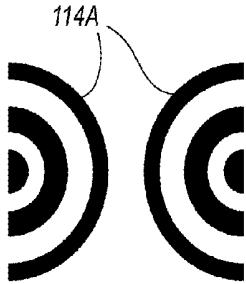

FIG. 7A

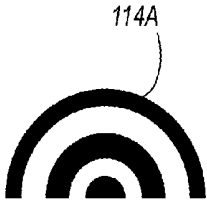

FIG. 7B



FIG. 7C

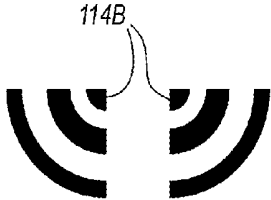

FIG. 7D

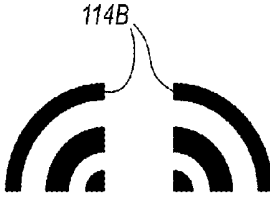

FIG. 7E

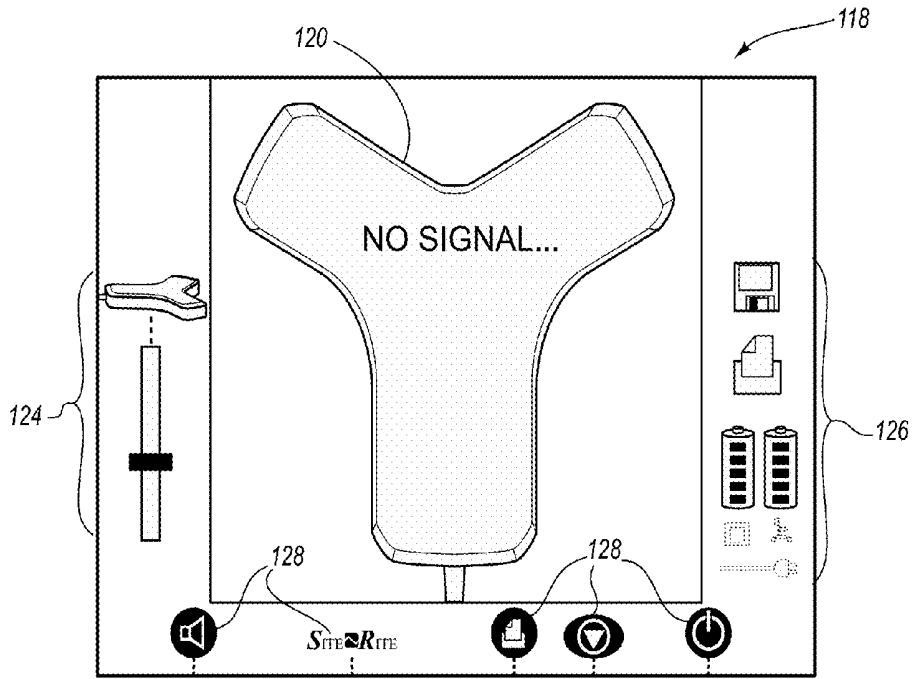

FIG. 8A

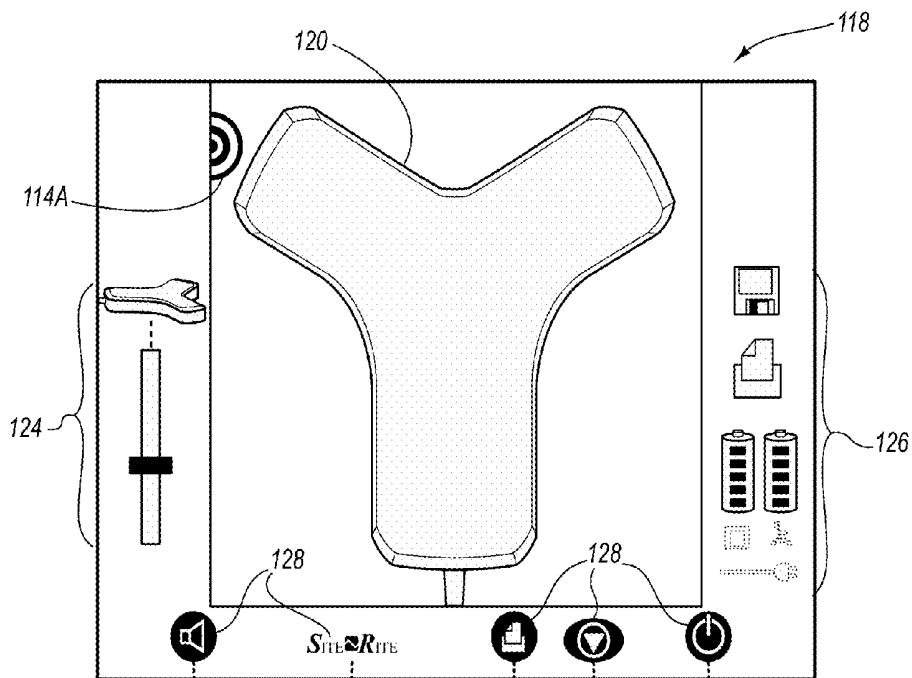

FIG. 8B

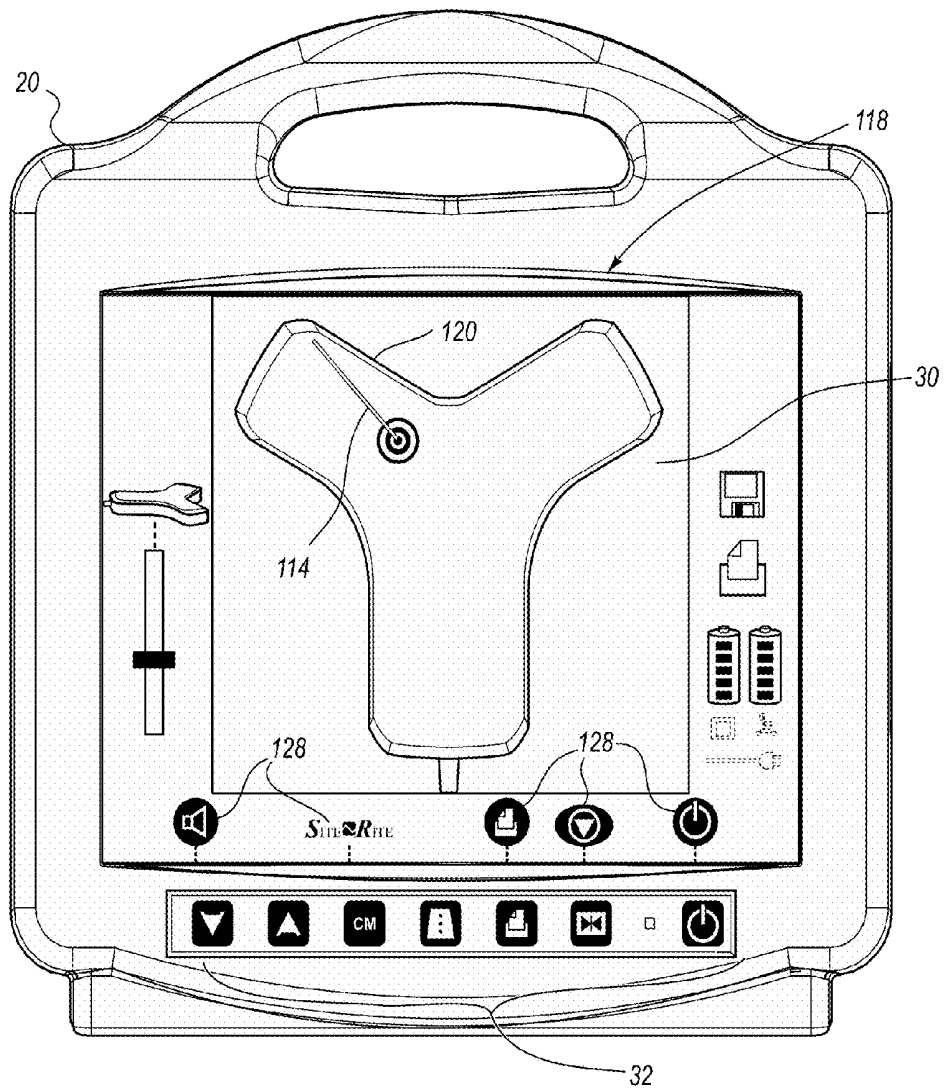

FIG. 8C

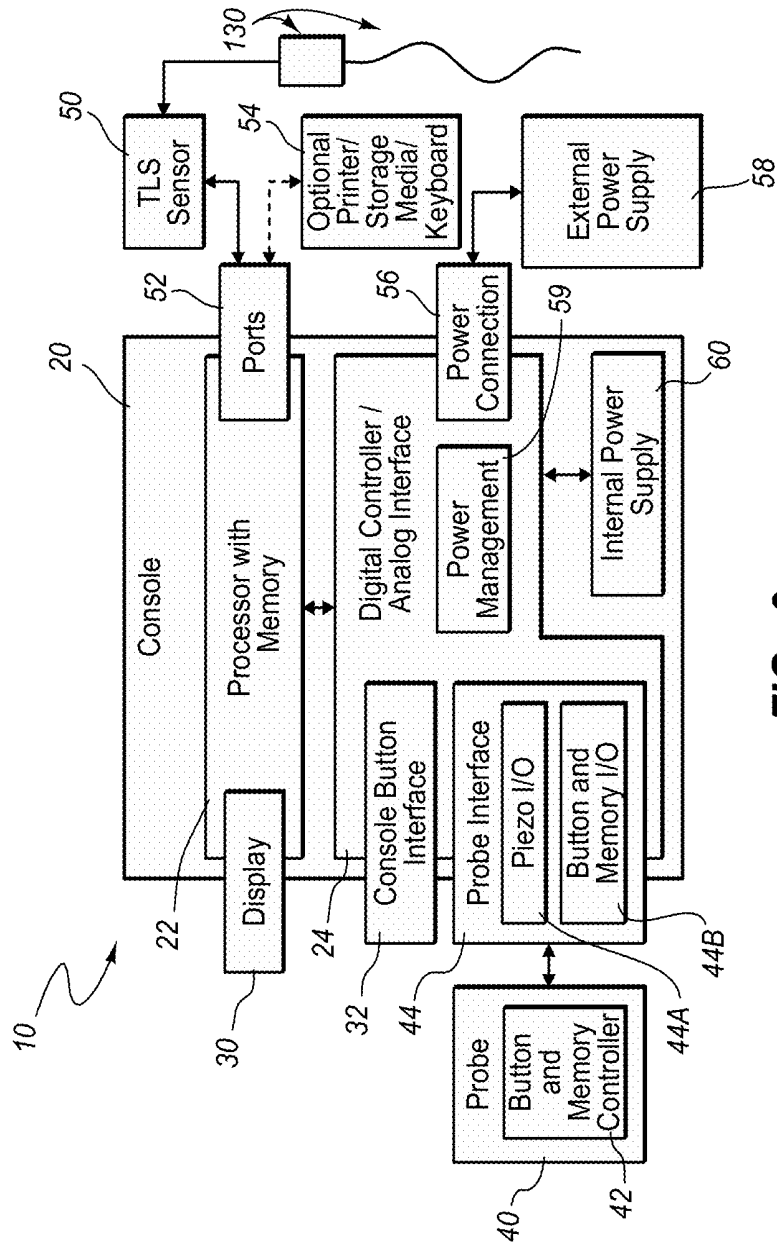

FIG. 9

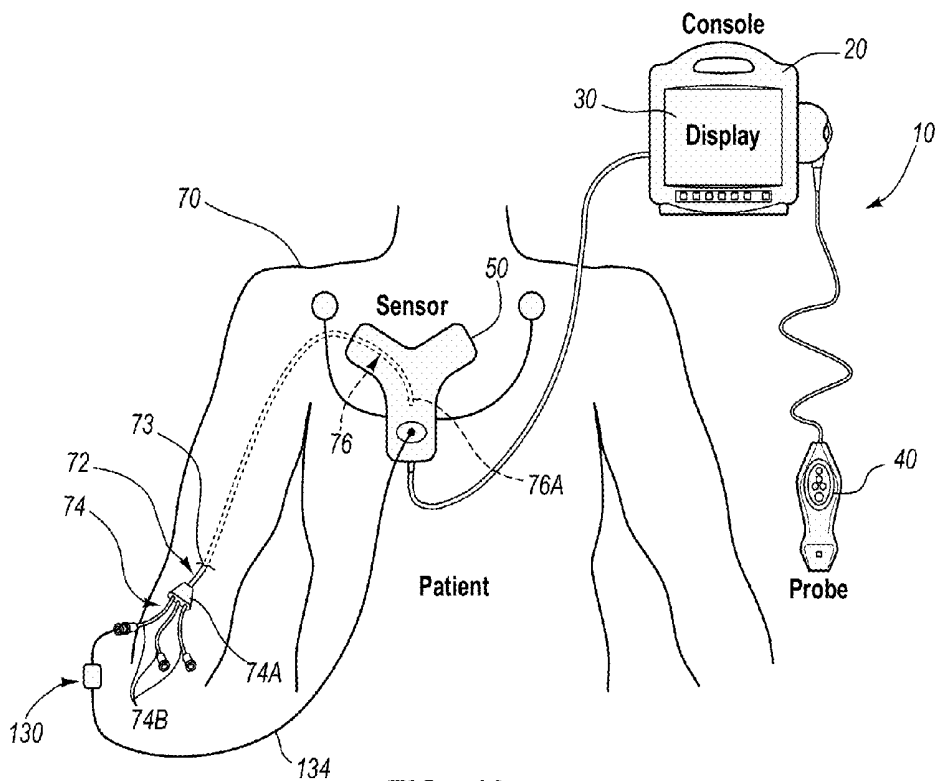

FIG. 10

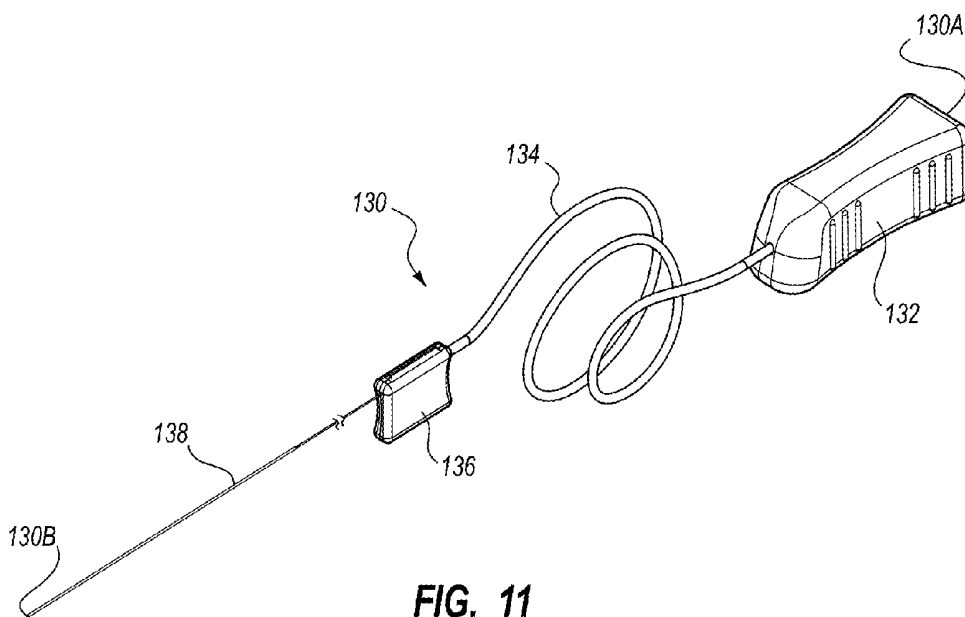

FIG. 11

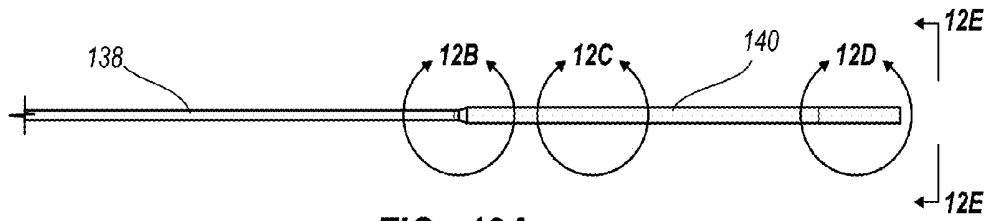

FIG. 12A

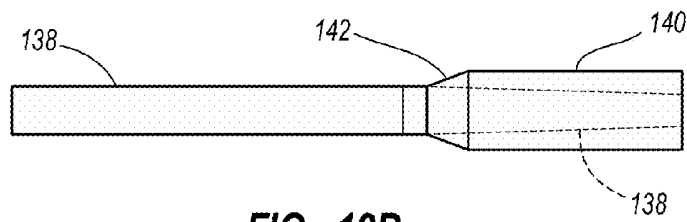

FIG. 12B

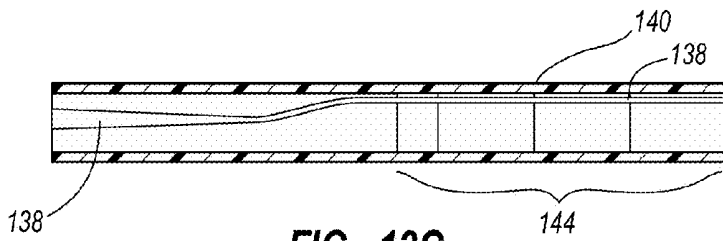

FIG. 12C

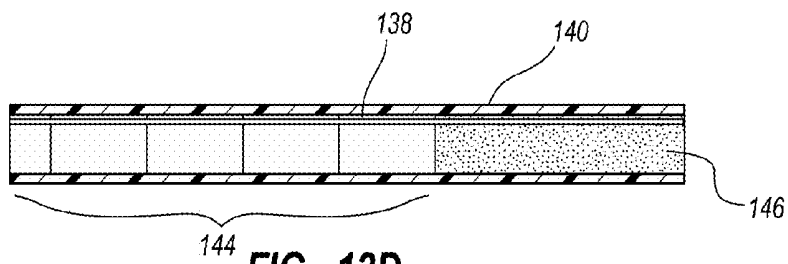

FIG. 12D

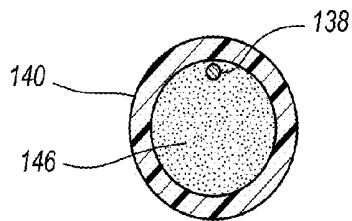

FIG. 12E

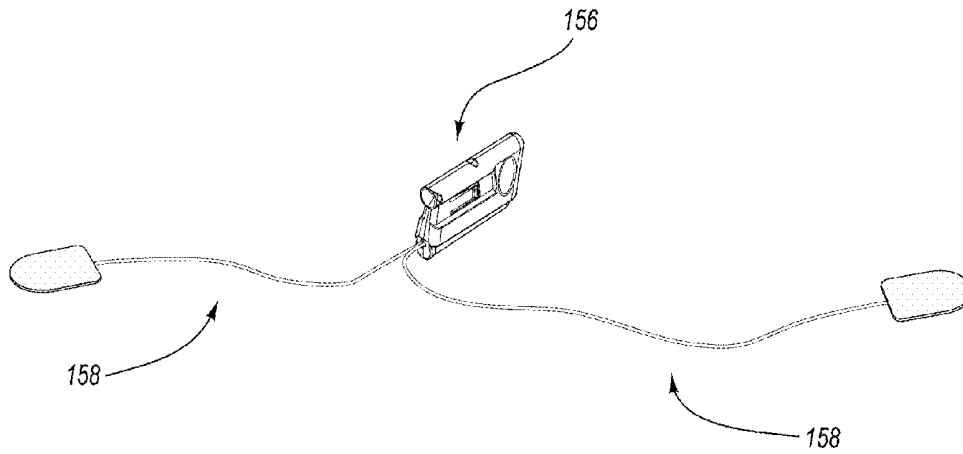

FIG. 13A

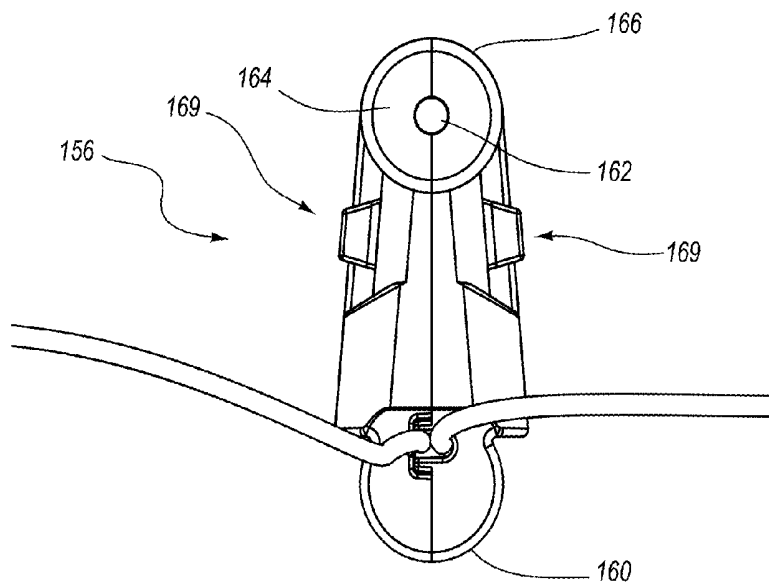

FIG. 13B

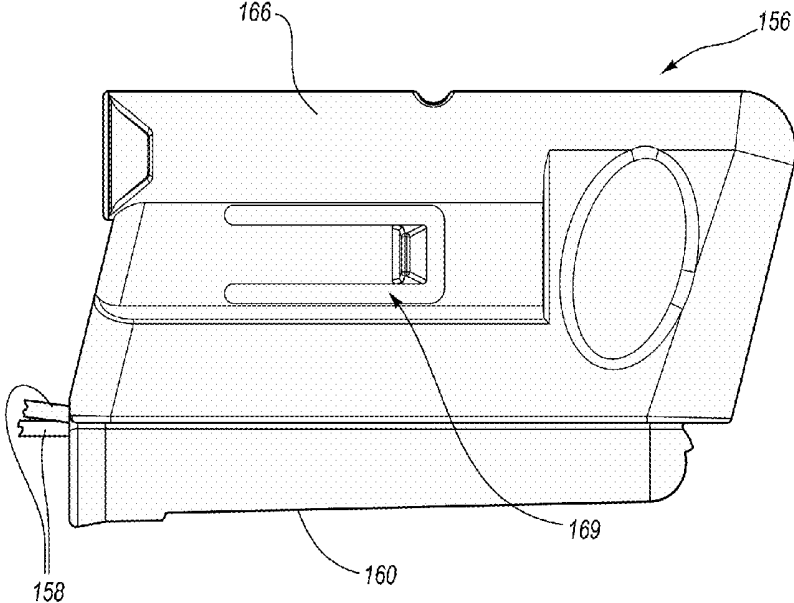

FIG. 13C

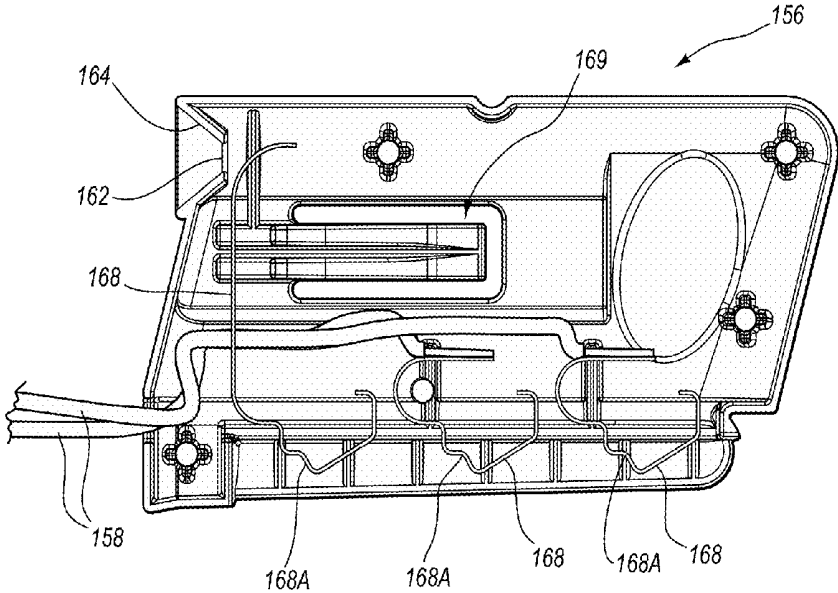

FIG. 13D

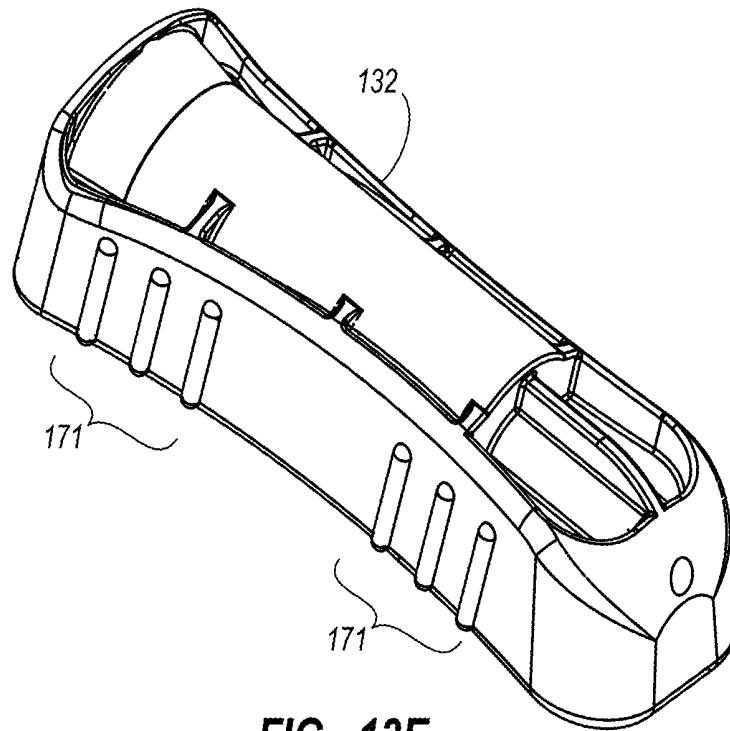

FIG. 13E

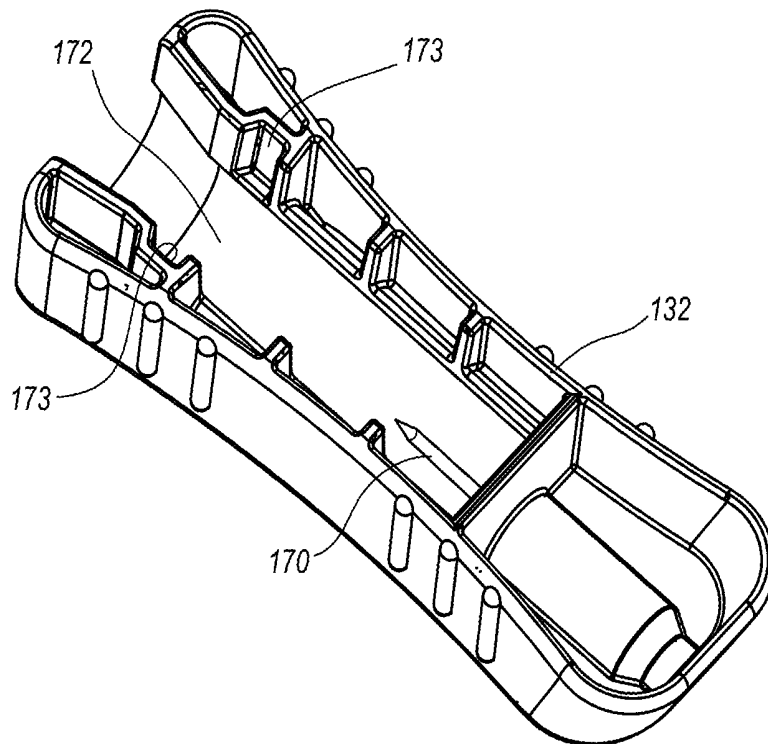

FIG. 13F

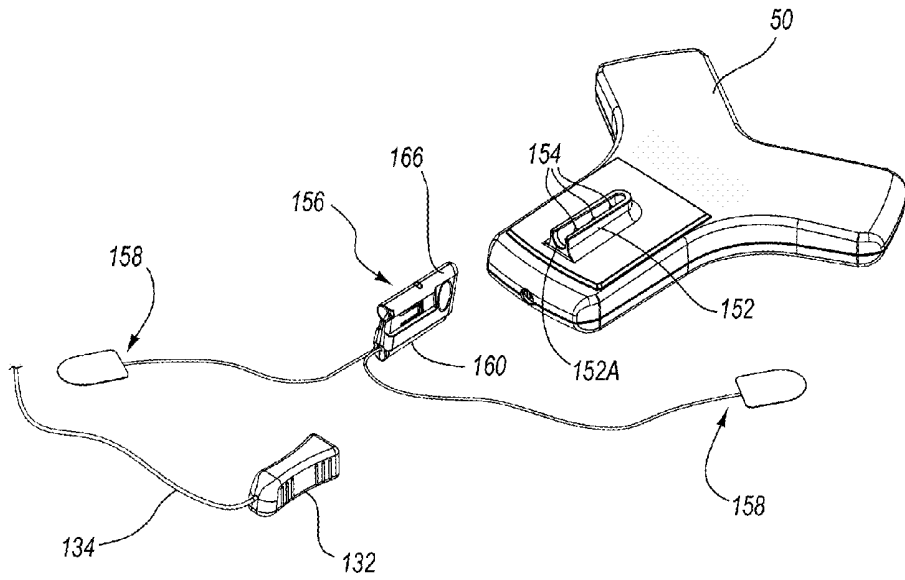

FIG. 14A

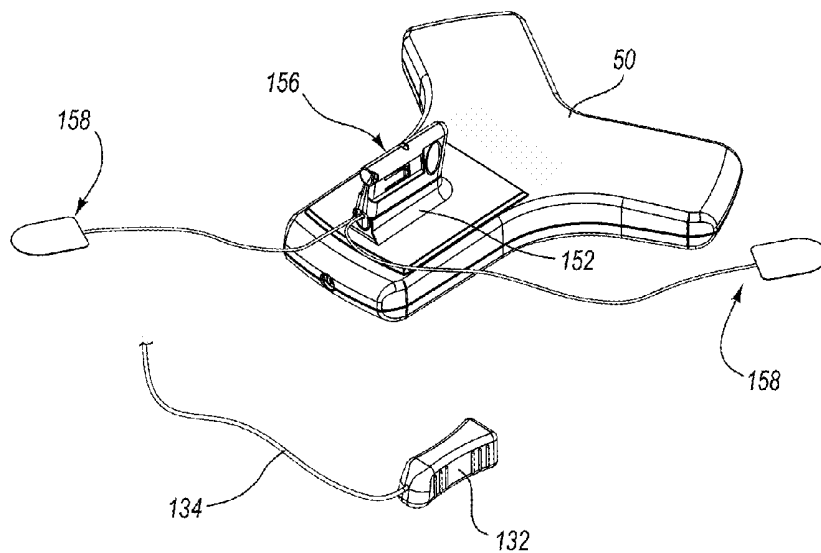

FIG. 14B

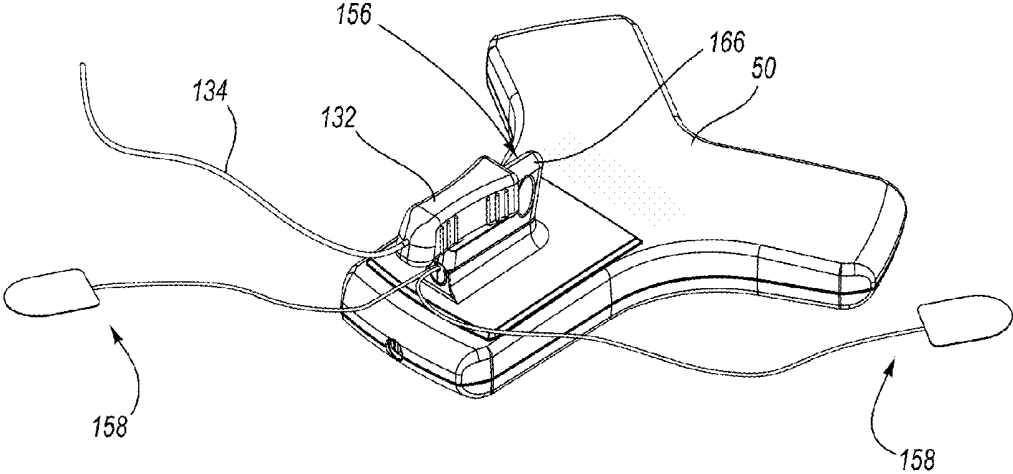

FIG. 14C

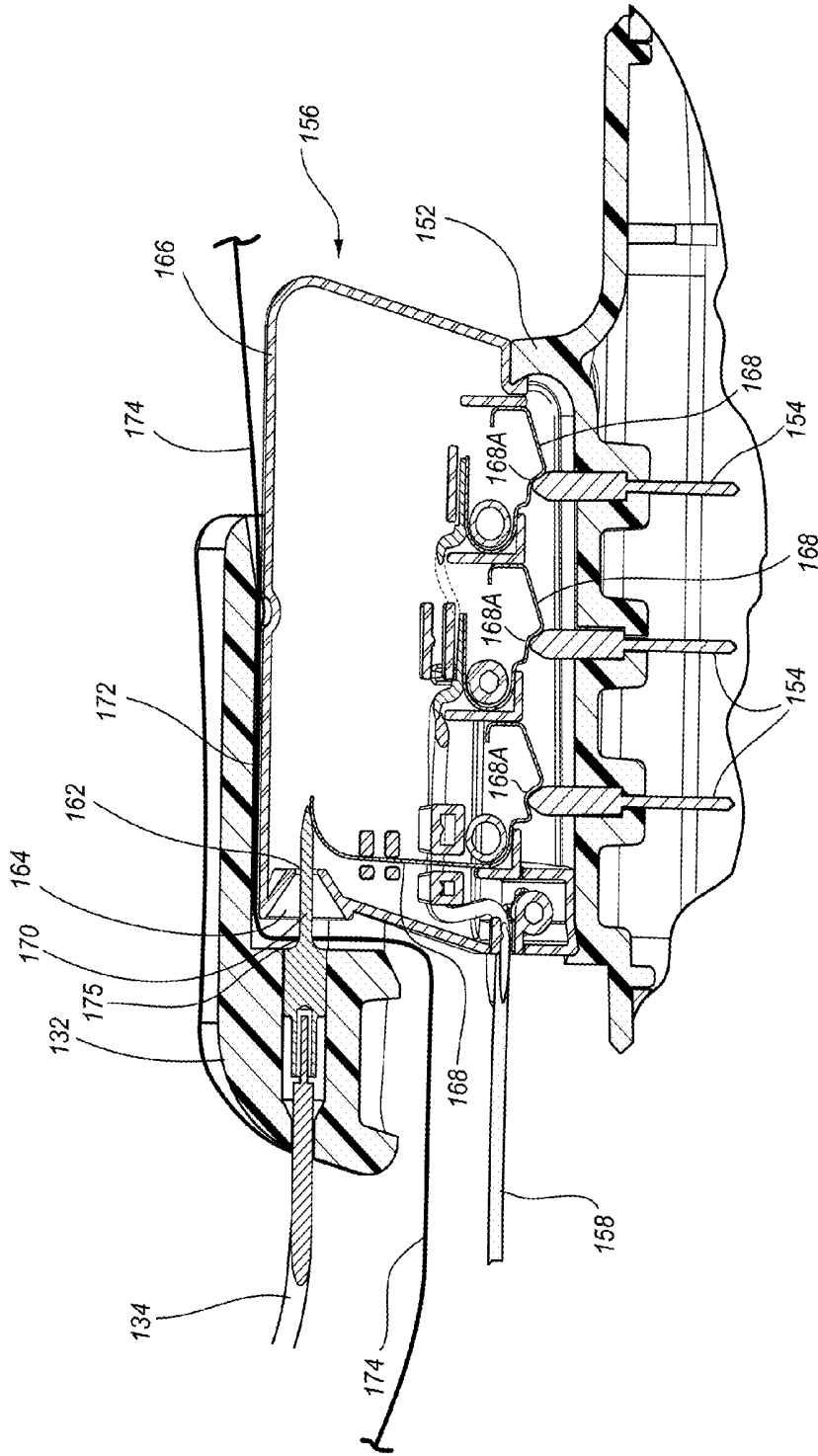

FIG. 15

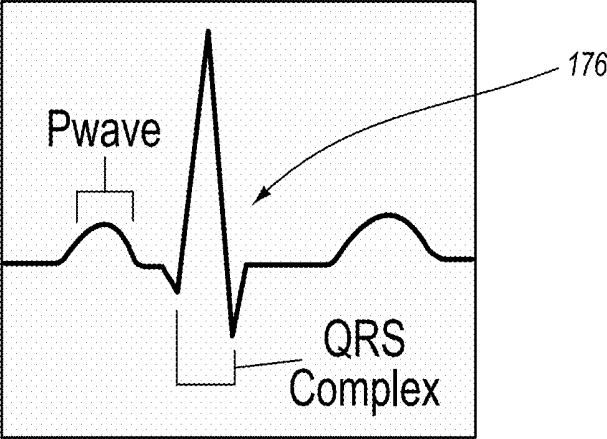

FIG. 16

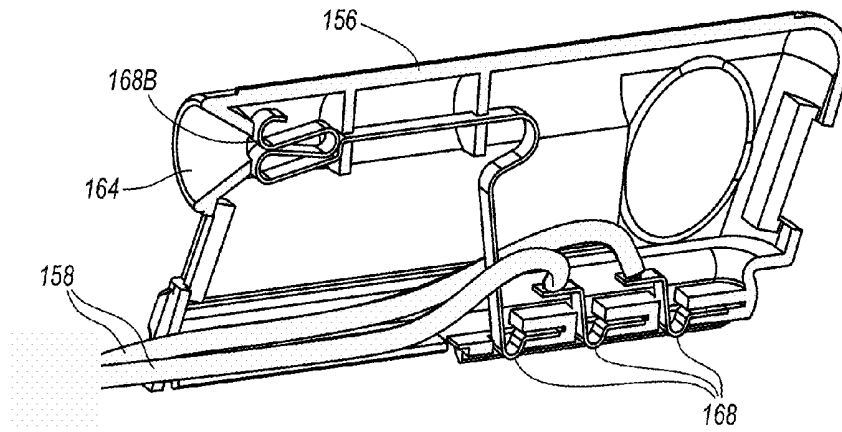

FIG. 18

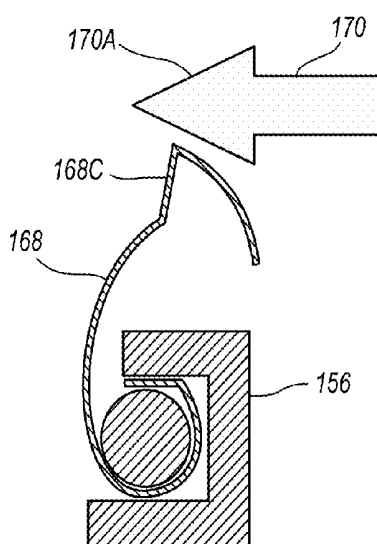

FIG. 19A

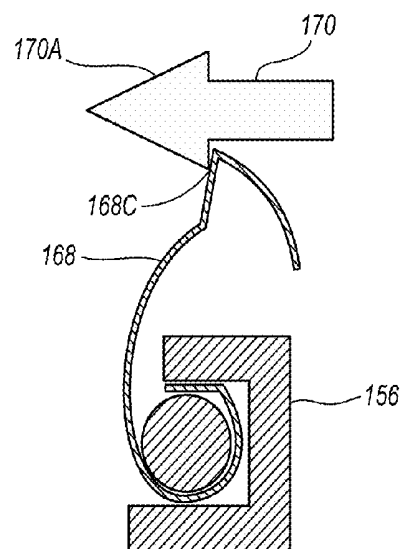
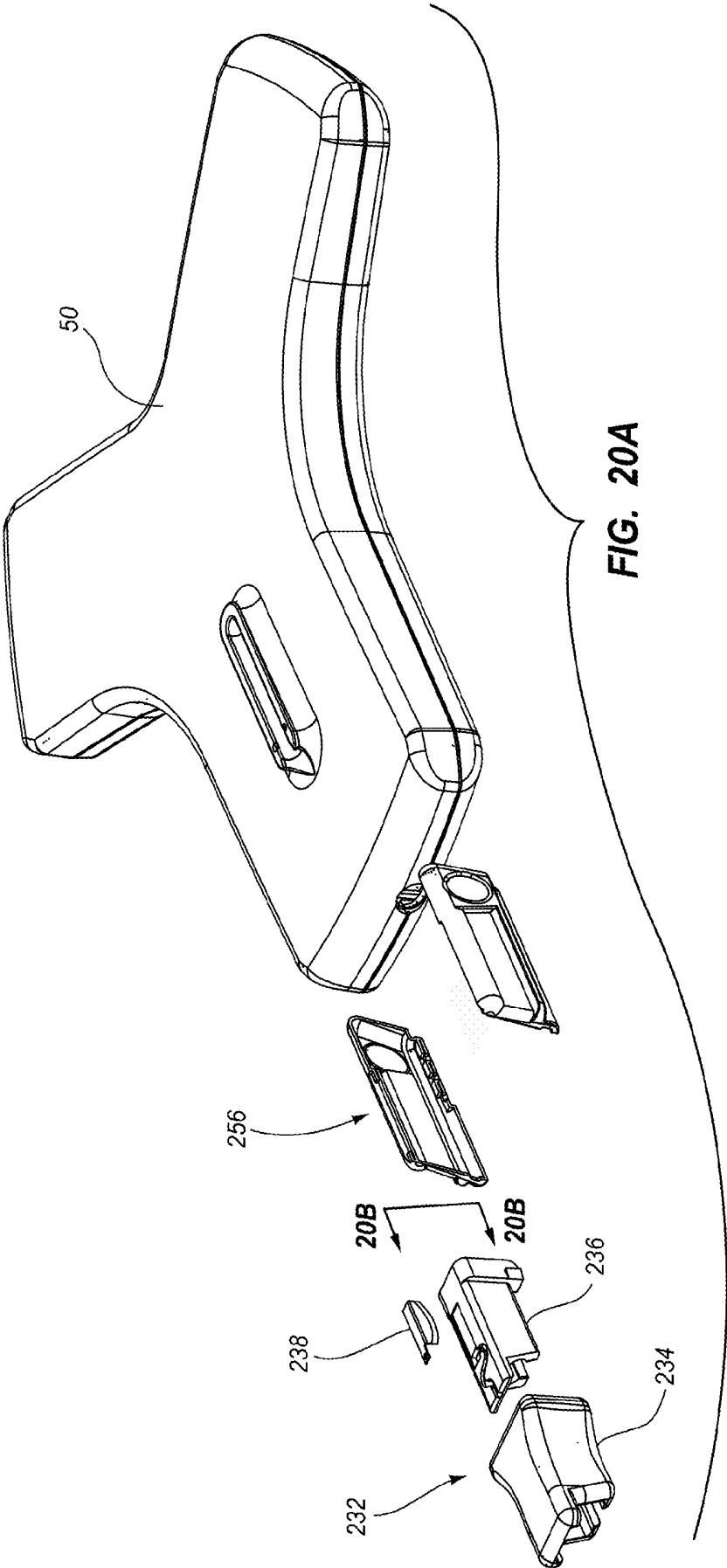

FIG. 19B



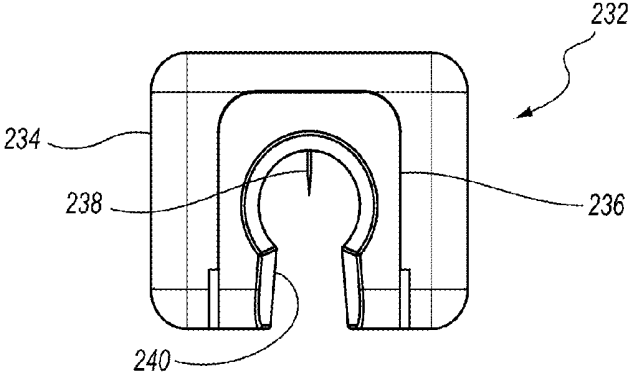

FIG. 20B

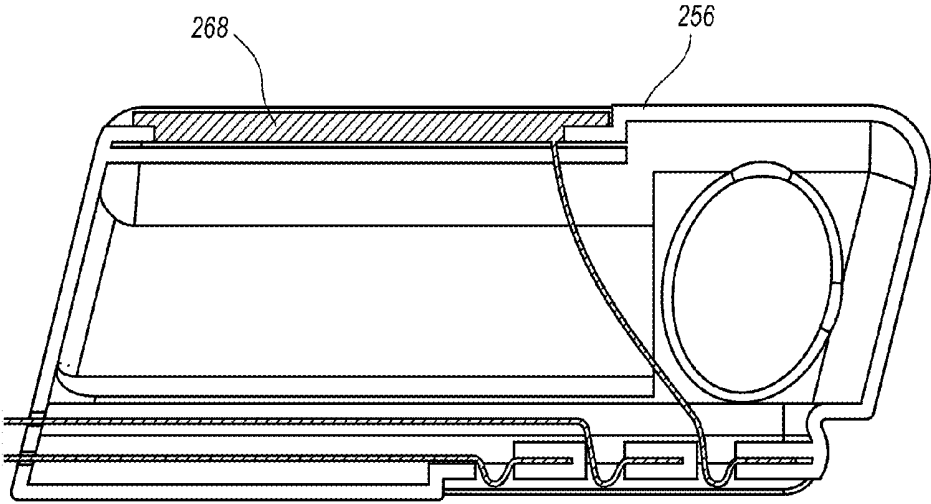

FIG. 20C

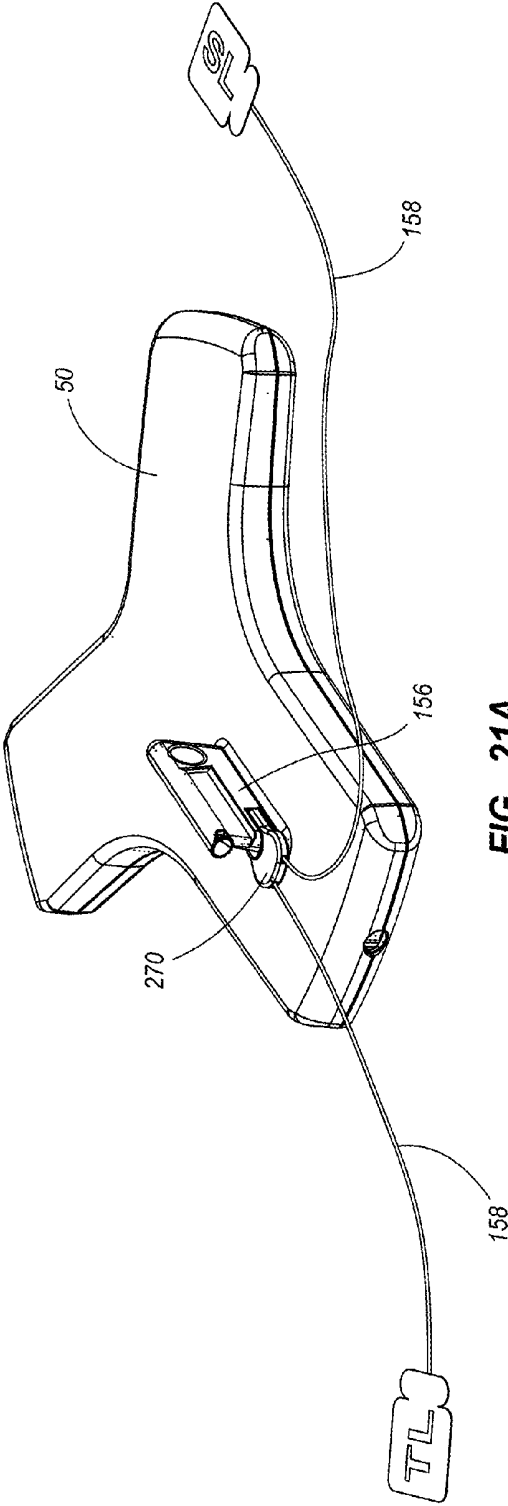

FIG. 21A

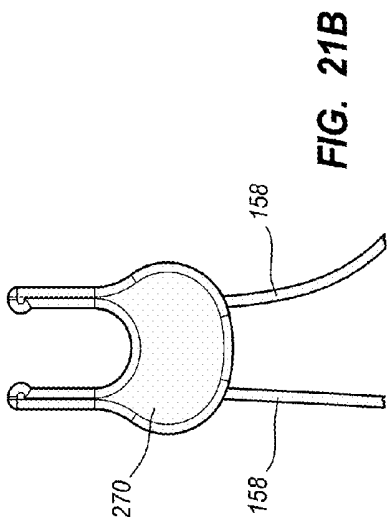

FIG. 21B

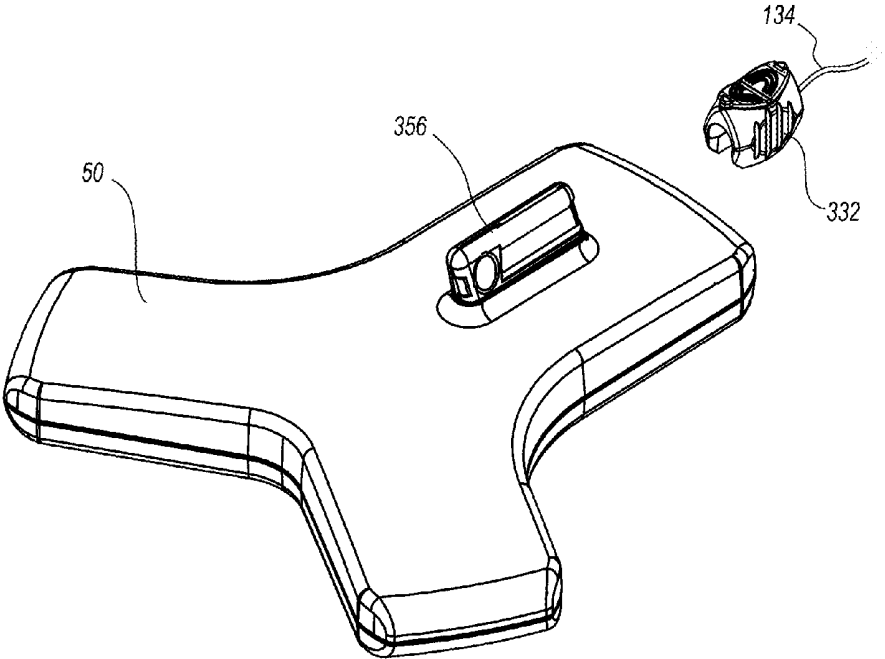

FIG. 22A

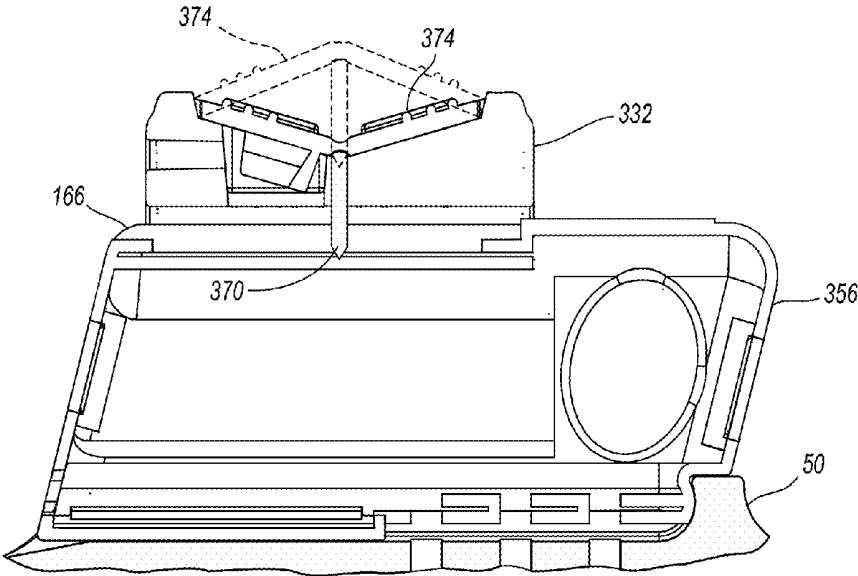

FIG. 22B

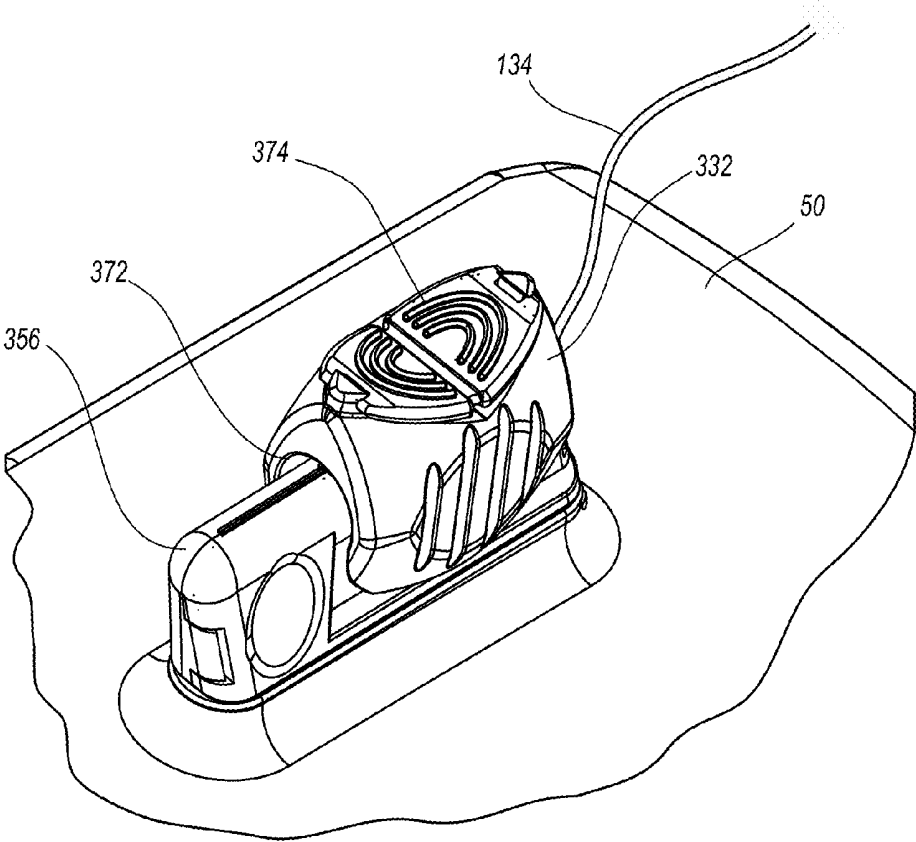

FIG. 22C

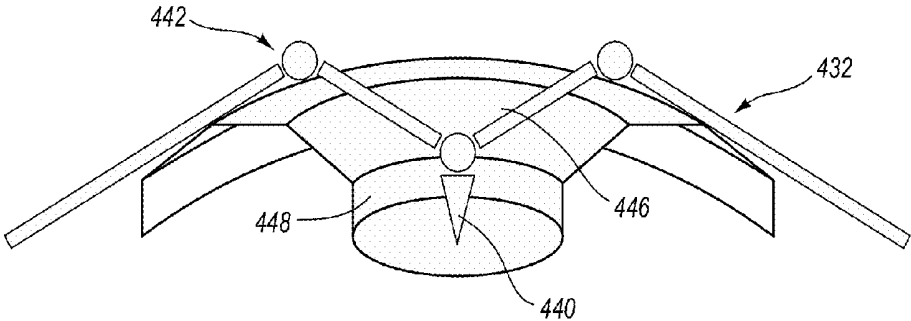

FIG. 23A

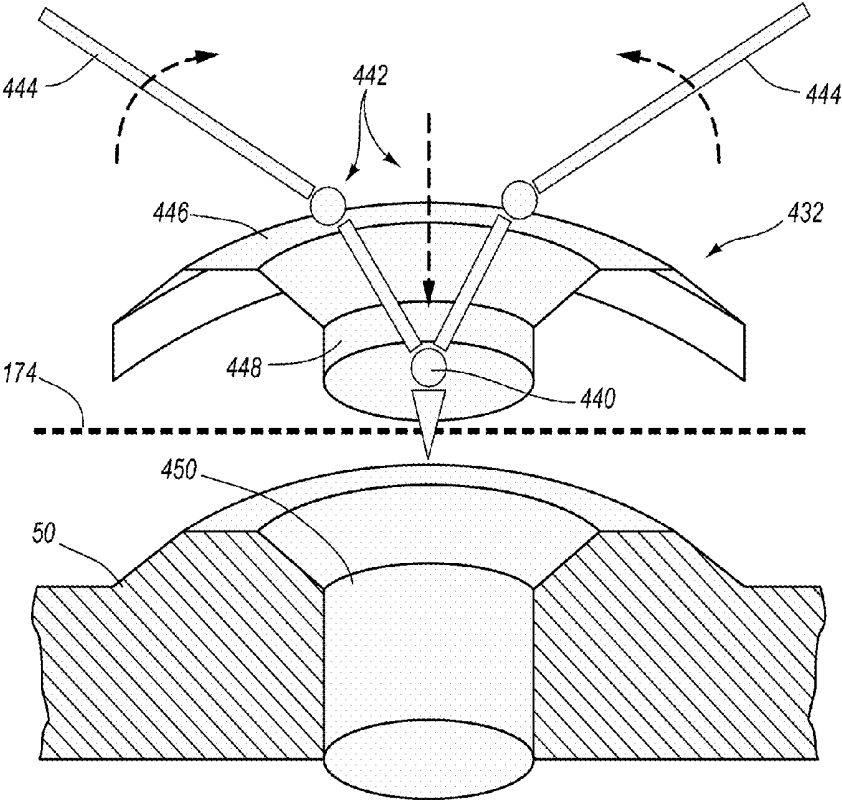

FIG. 23B

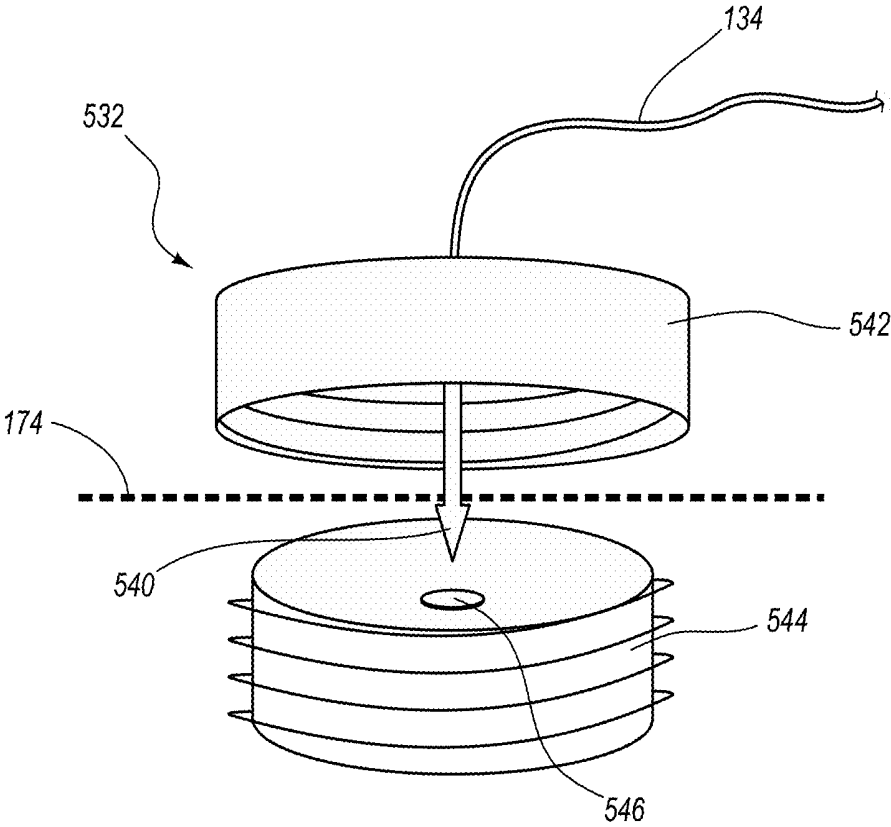

FIG. 24

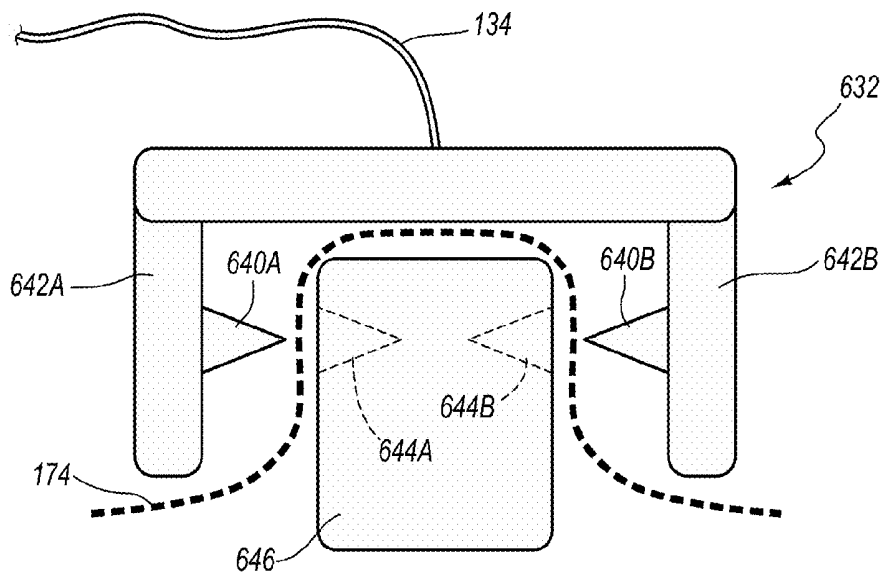

FIG. 25A

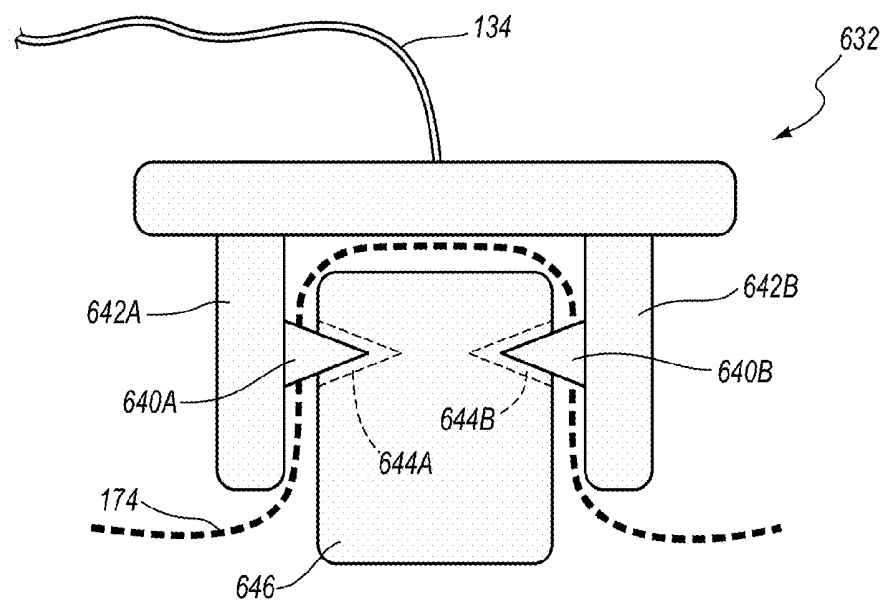

FIG. 25B

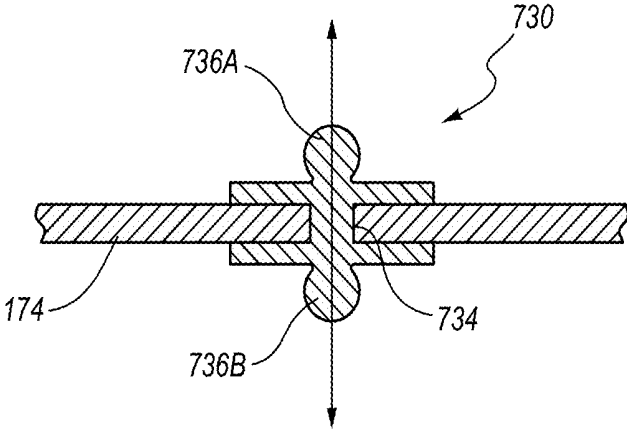

FIG. 26A

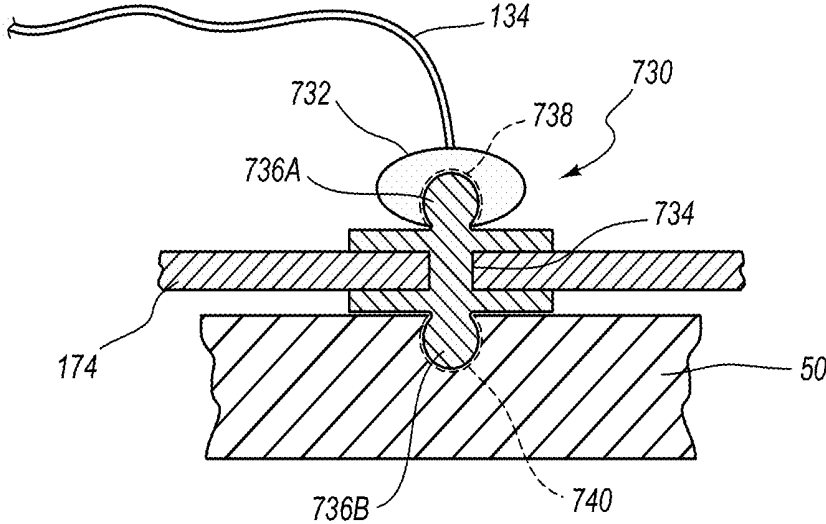

FIG. 26B

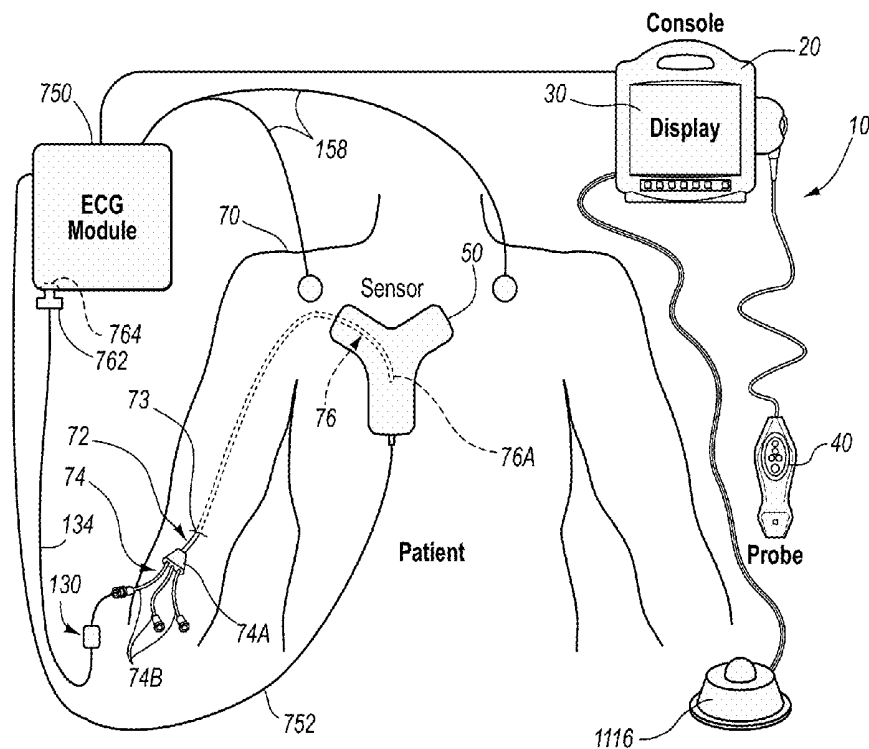

FIG. 27

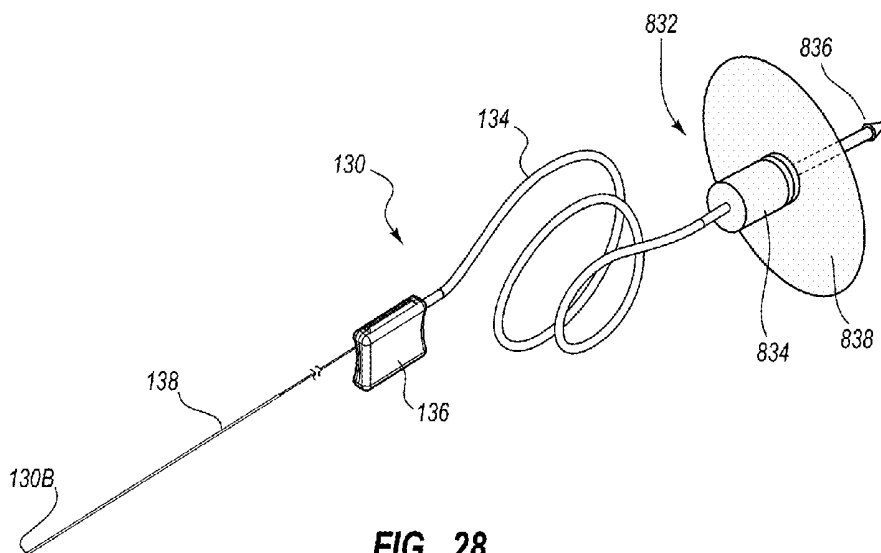

FIG. 28

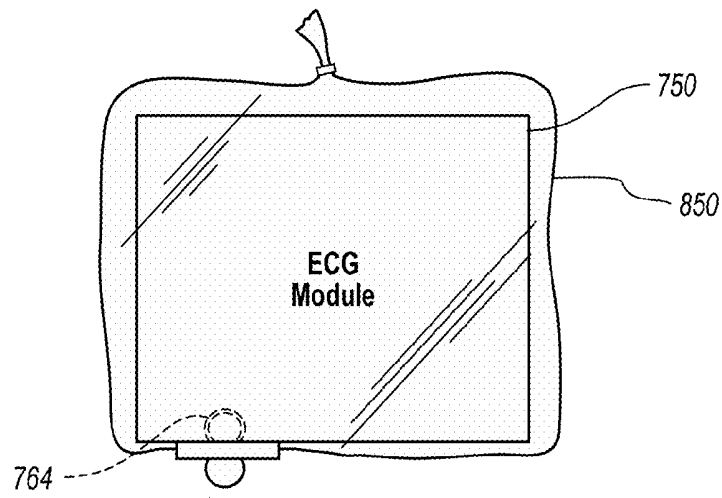

FIG. 29A

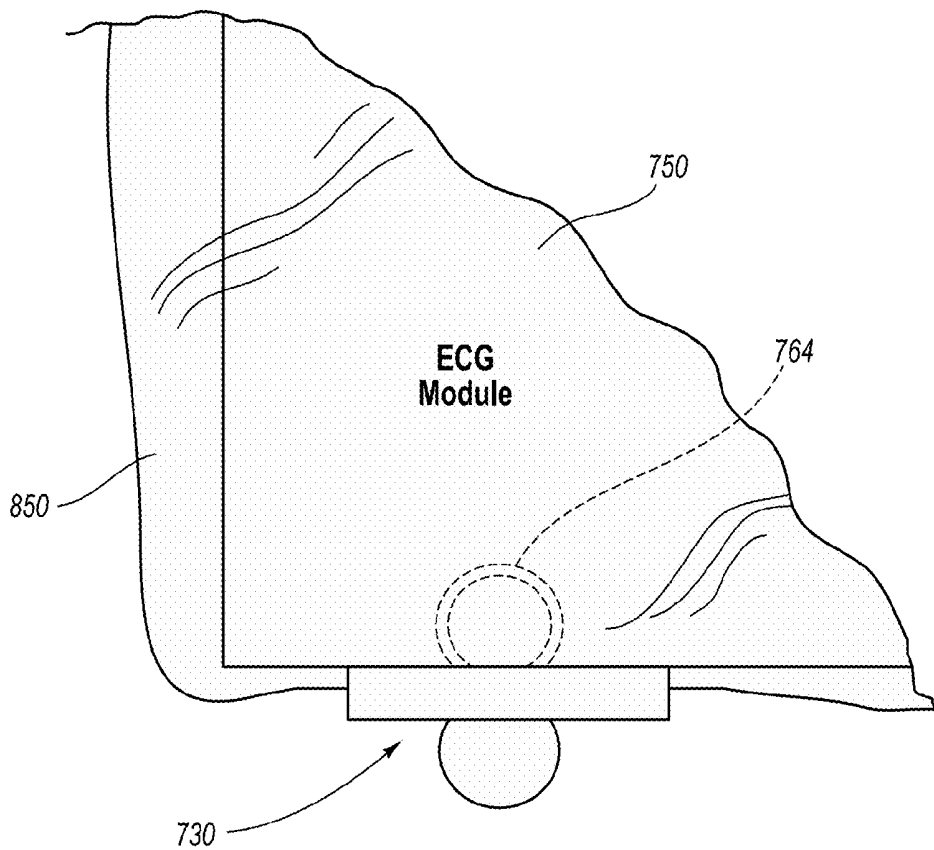

FIG. 29B

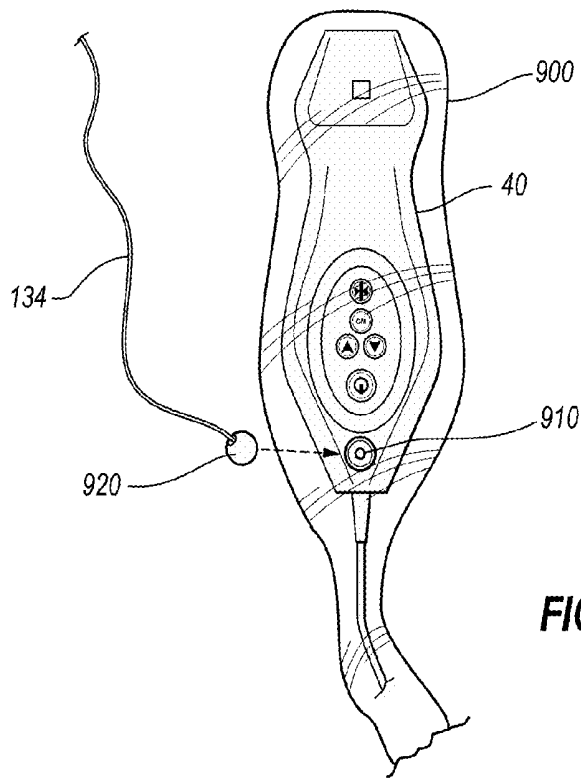

FIG. 32

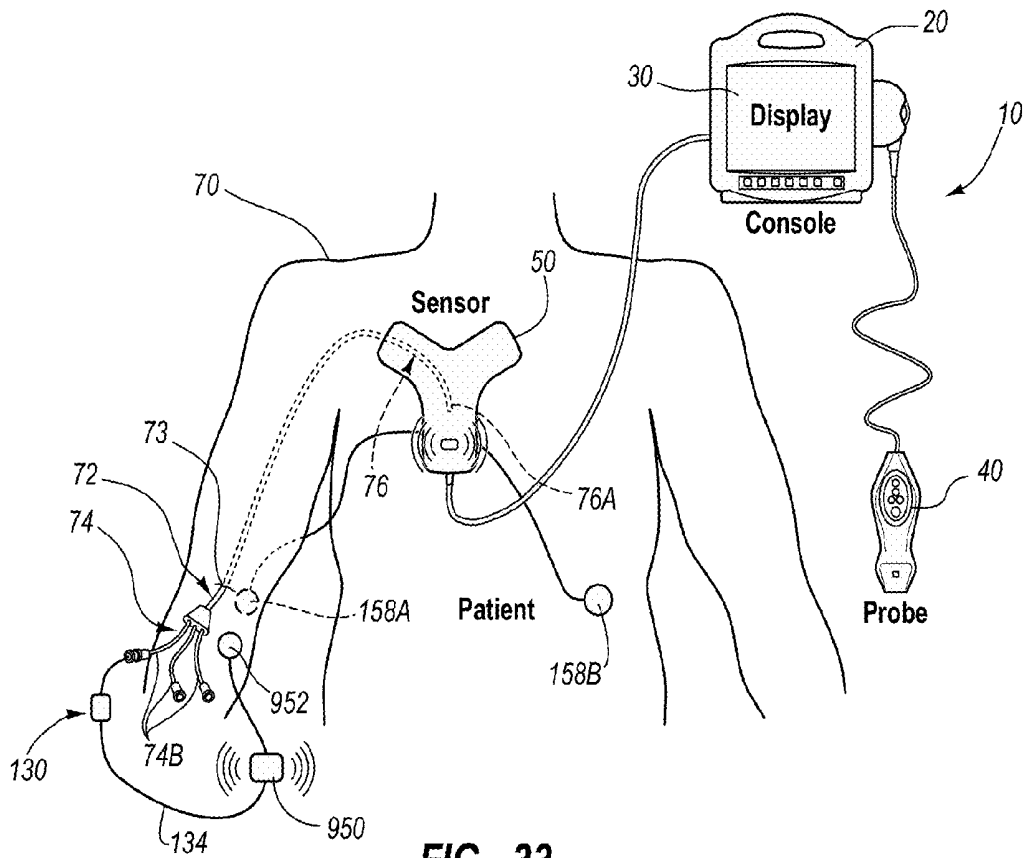

FIG. 33

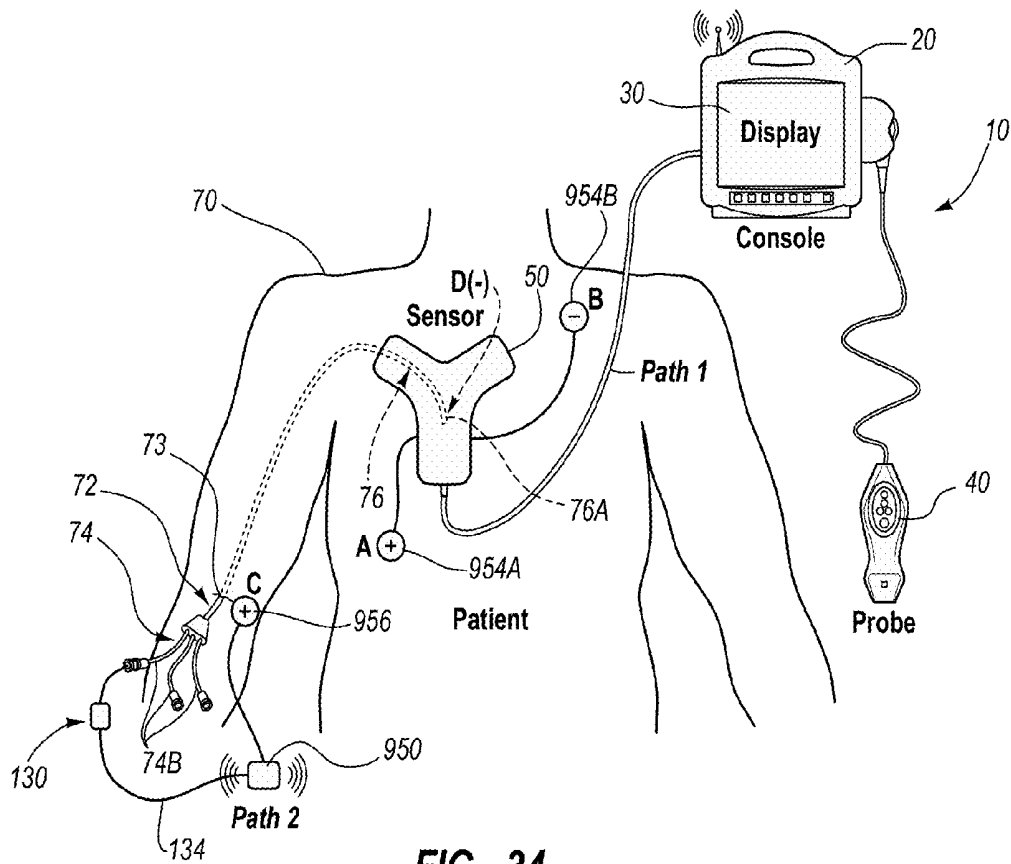

FIG. 34

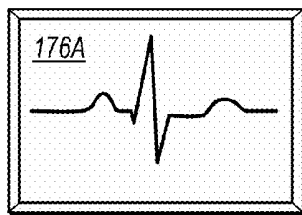

FIG. 35A

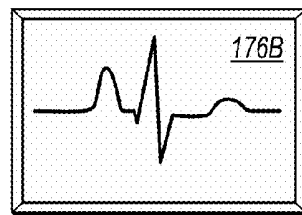

FIG. 35B

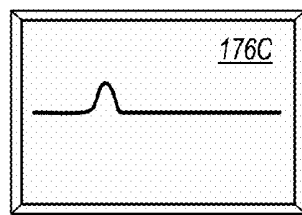

FIG. 35C

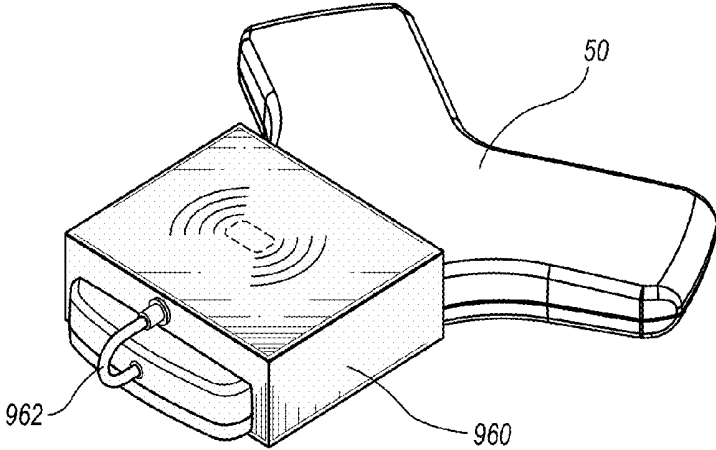

FIG. 36

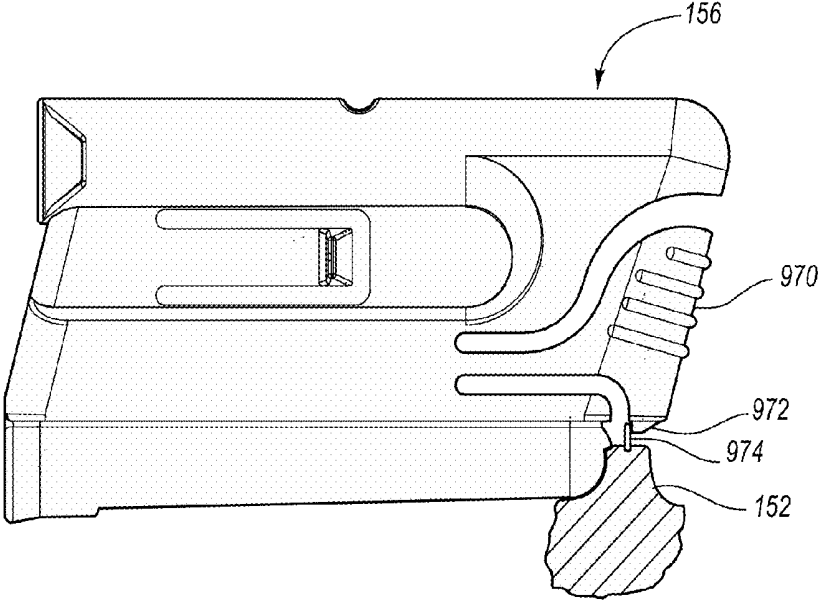

FIG. 37

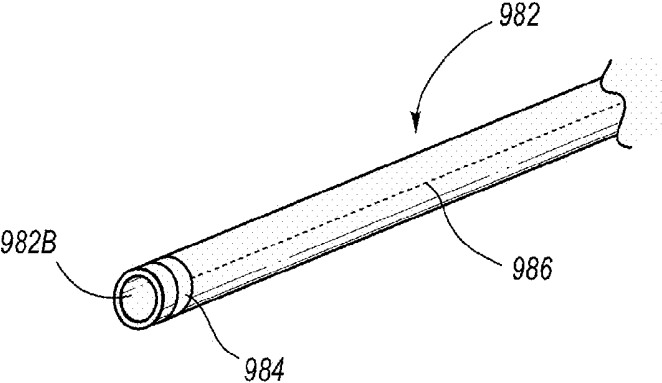

FIG. 38

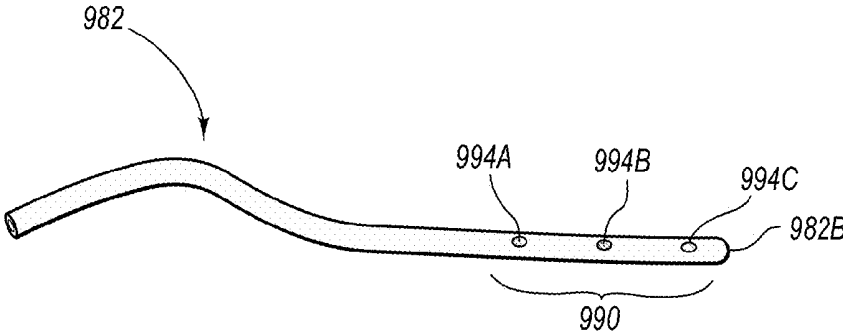

FIG. 39

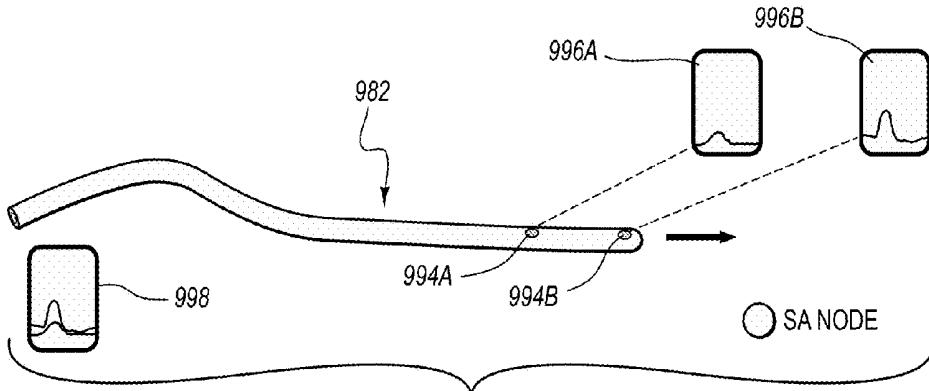

FIG. 40A

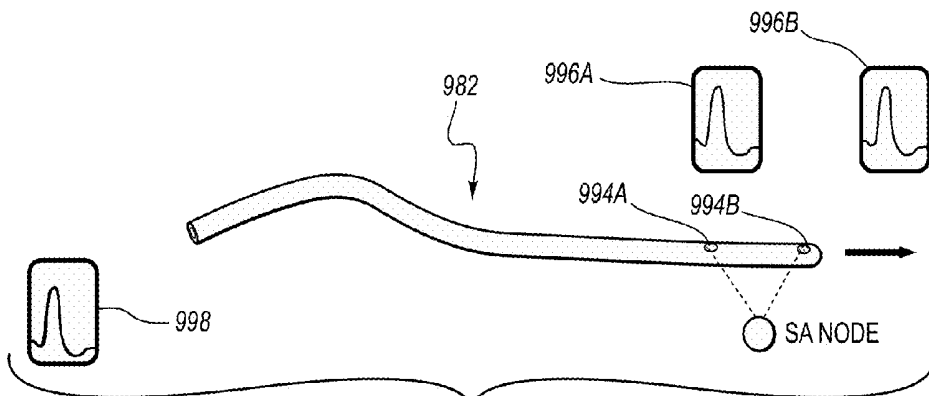

FIG. 40B

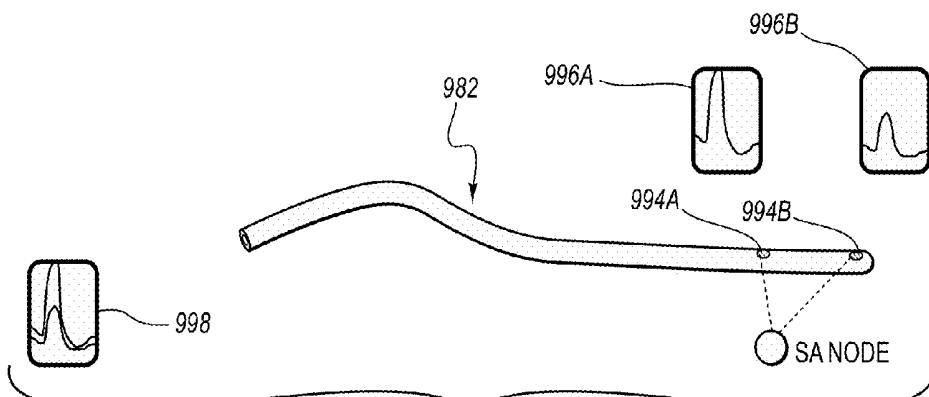

FIG. 40C

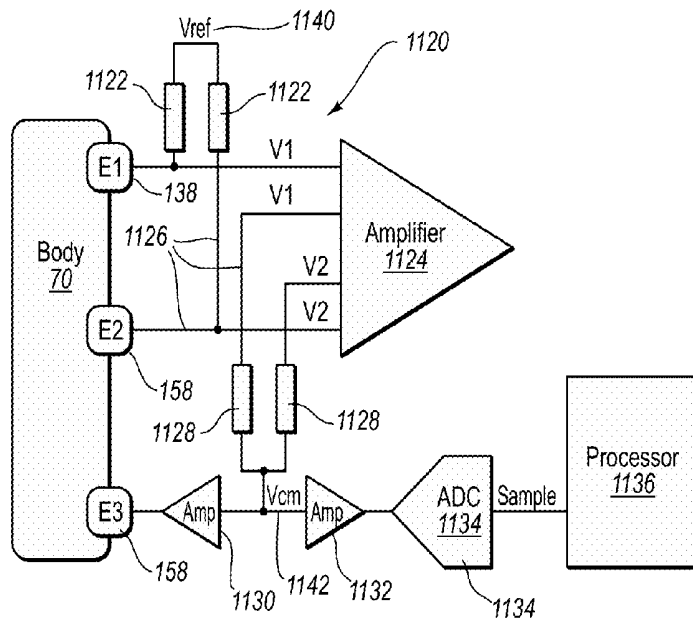
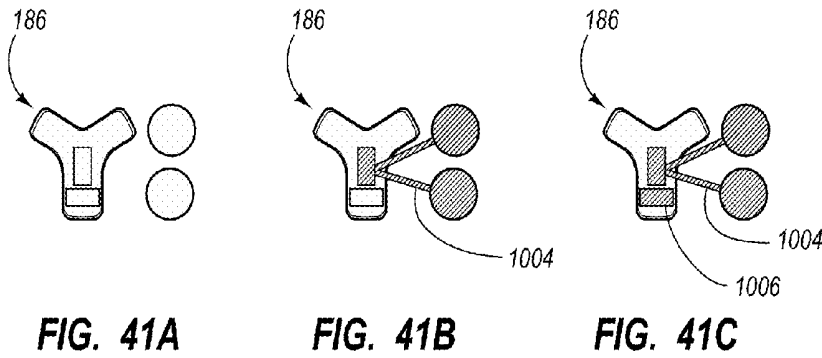

FIG. 41D

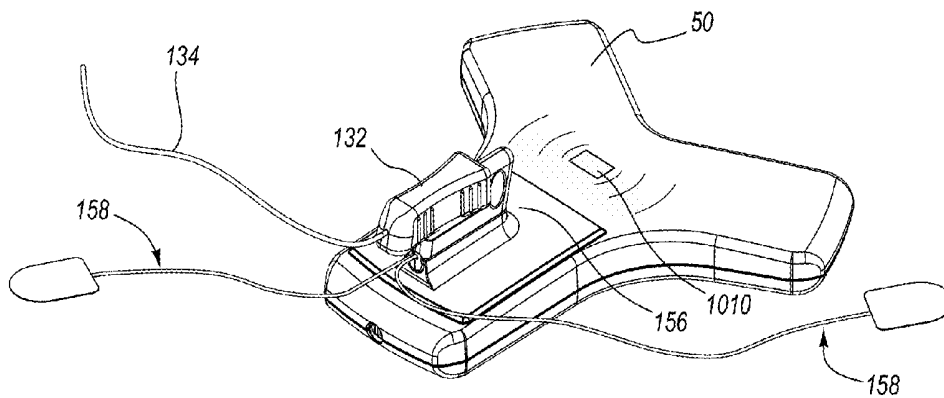

FIG. 42

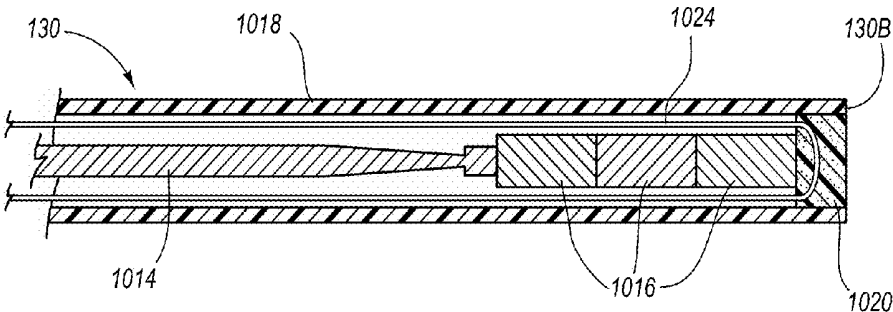

FIG. 43A

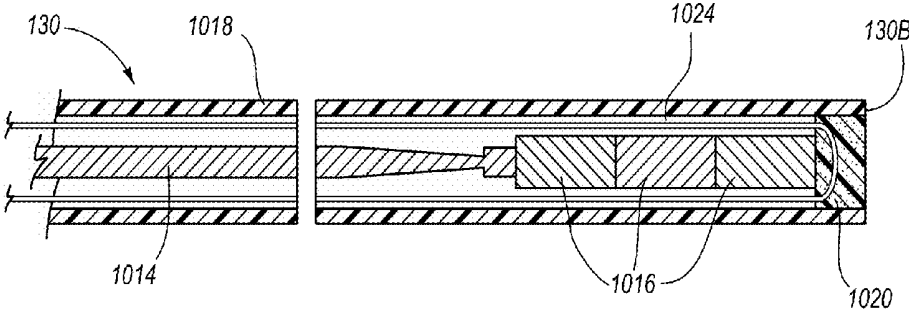

FIG. 43B

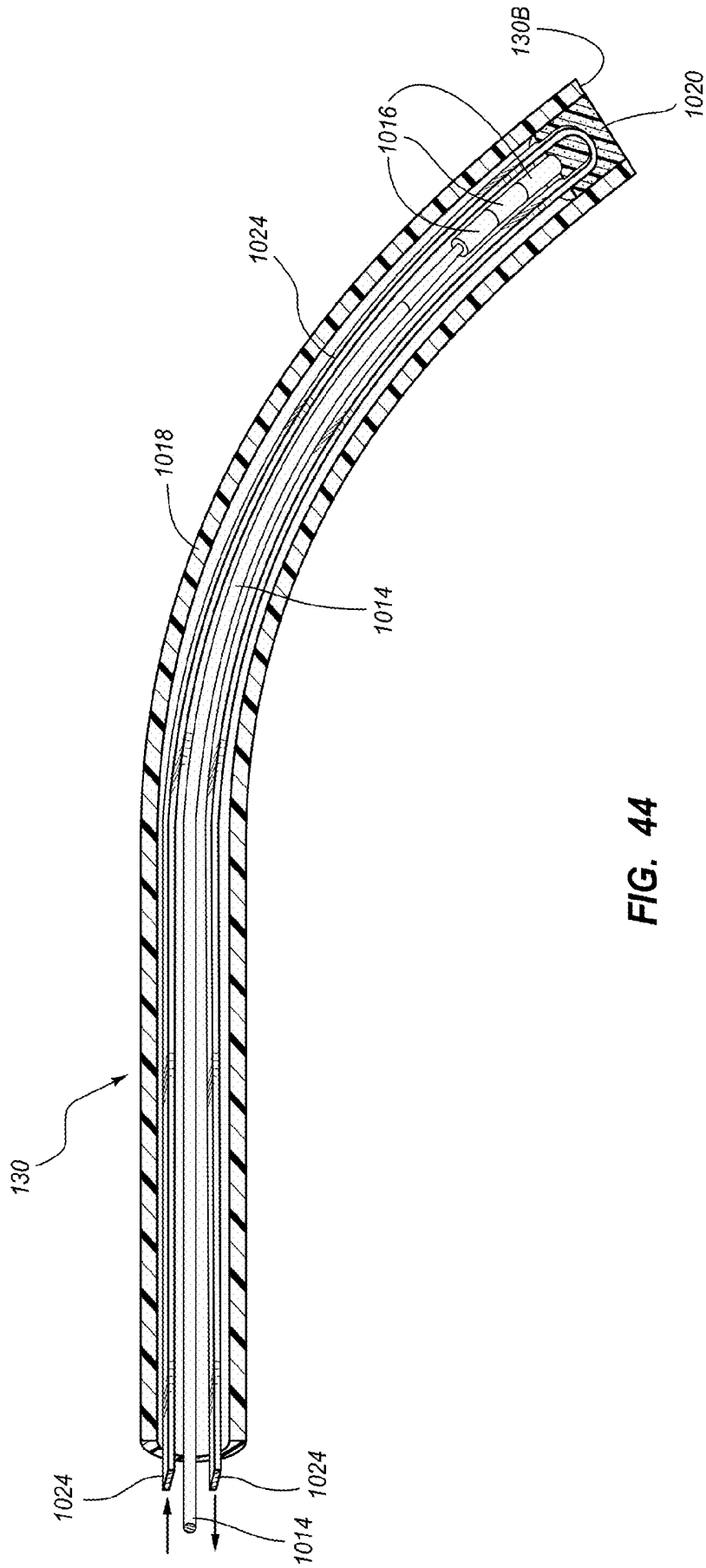

FIG. 44

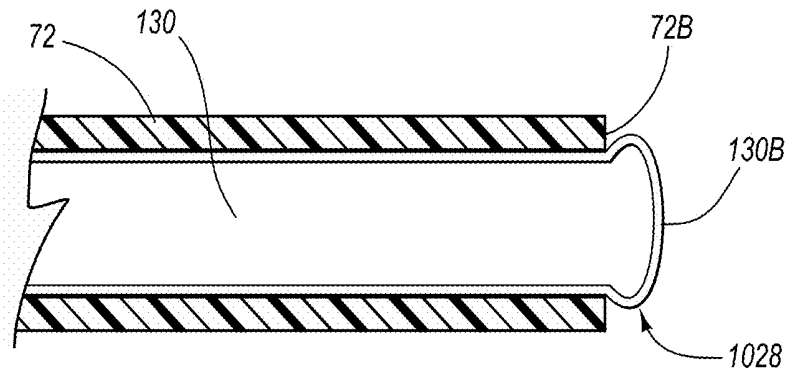

FIG. 45

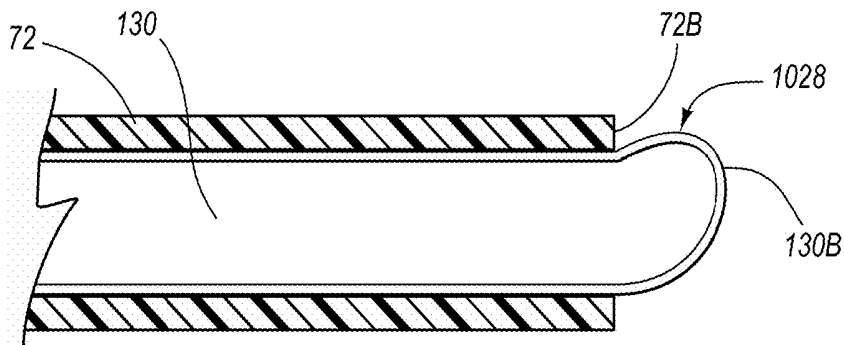

FIG. 46

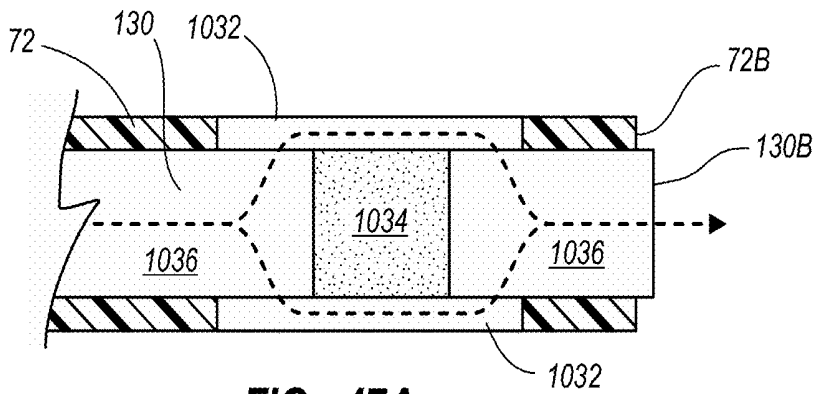

FIG. 47A

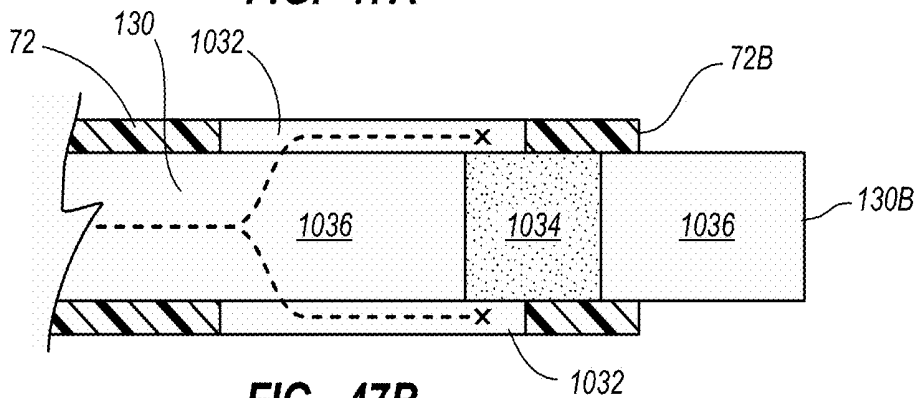

FIG. 47B

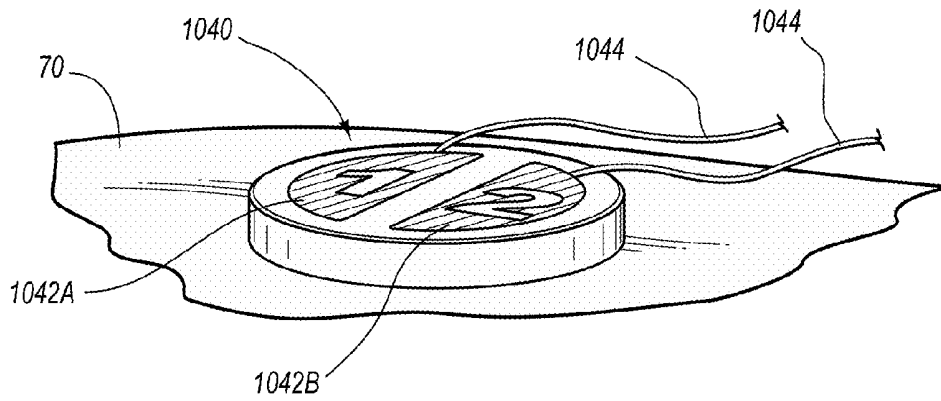

FIG. 48

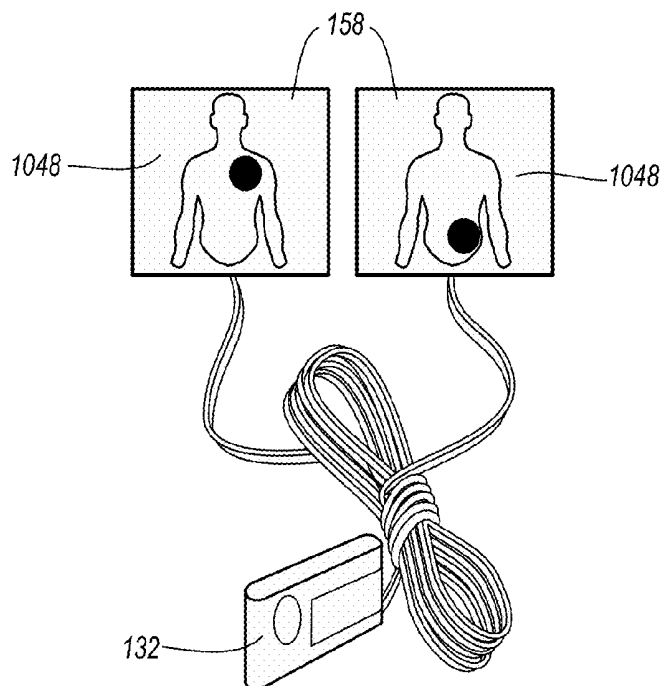

FIG. 49

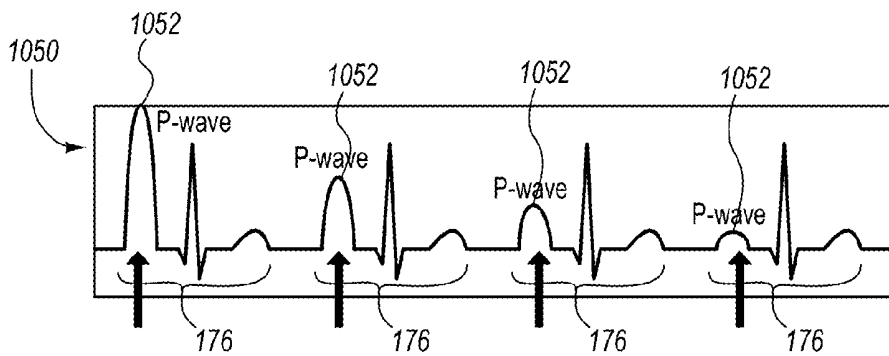

FIG. 50

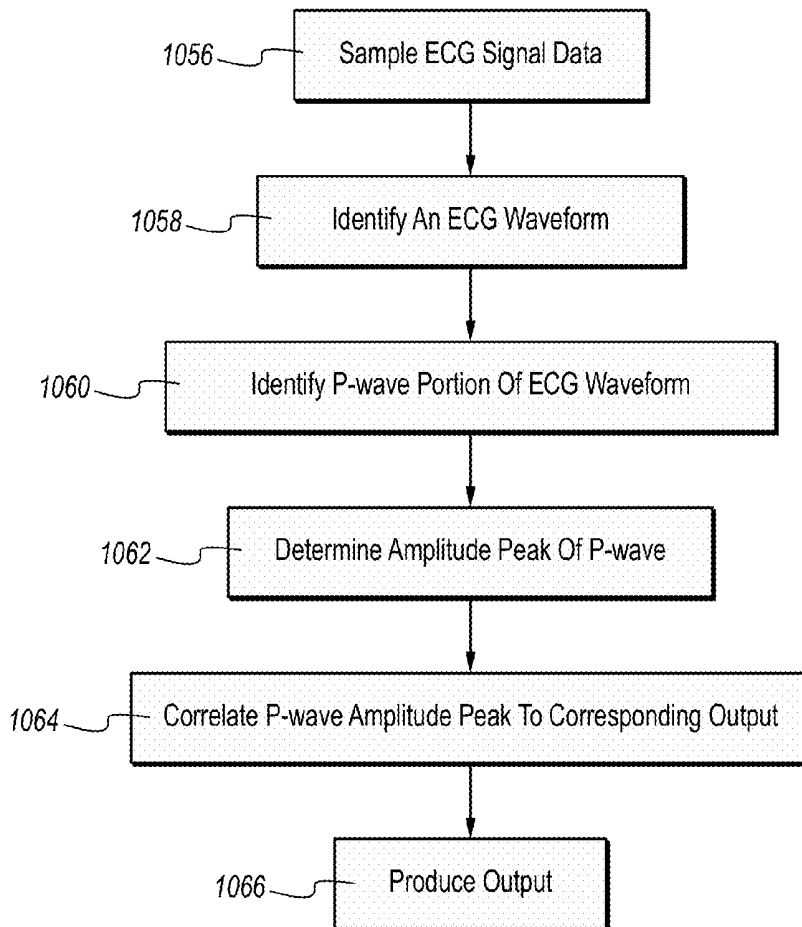

FIG. 51

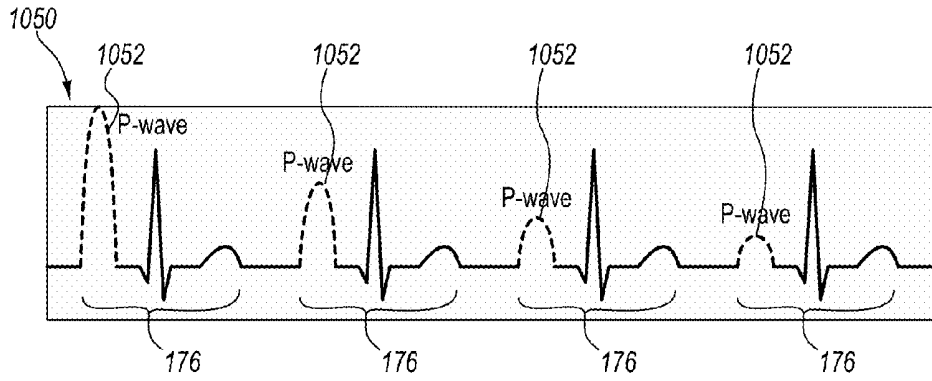

FIG. 52

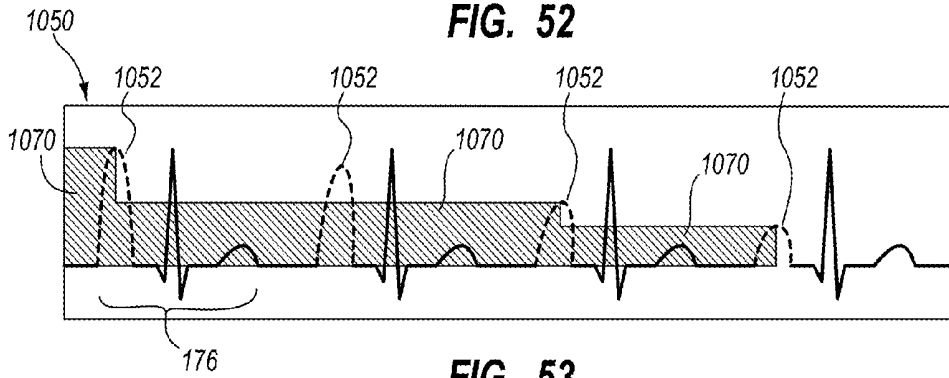

FIG. 53

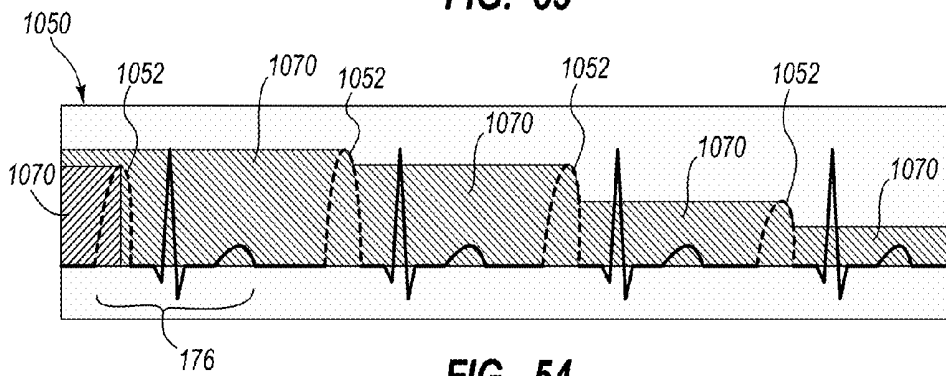

FIG. 54

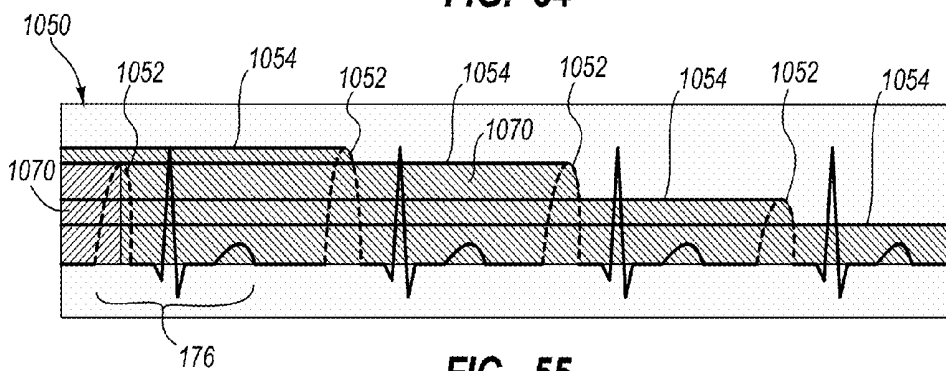

FIG. 55

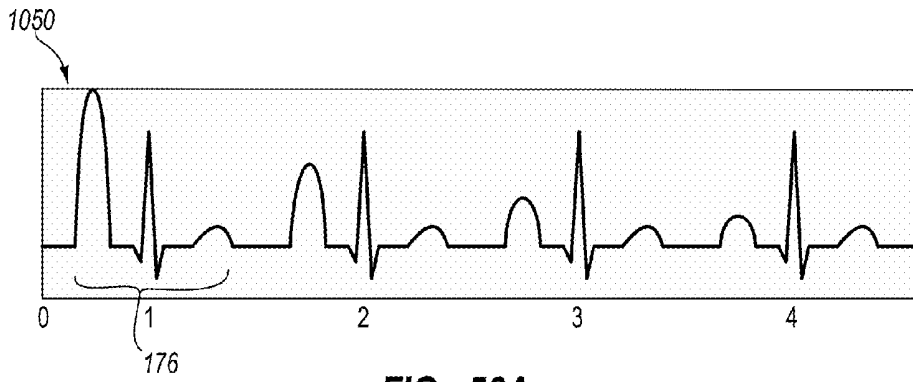

FIG. 56A

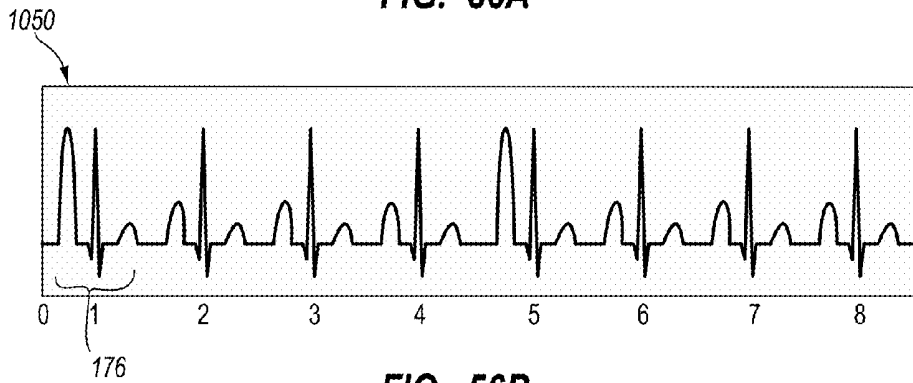

FIG. 56B

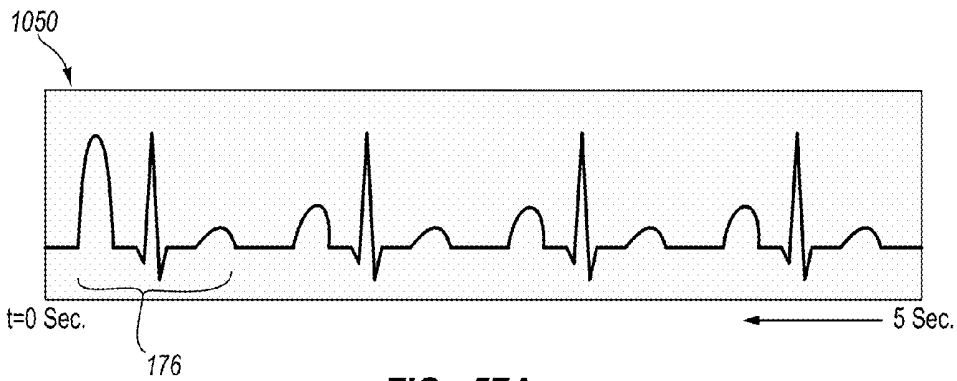

FIG. 57A

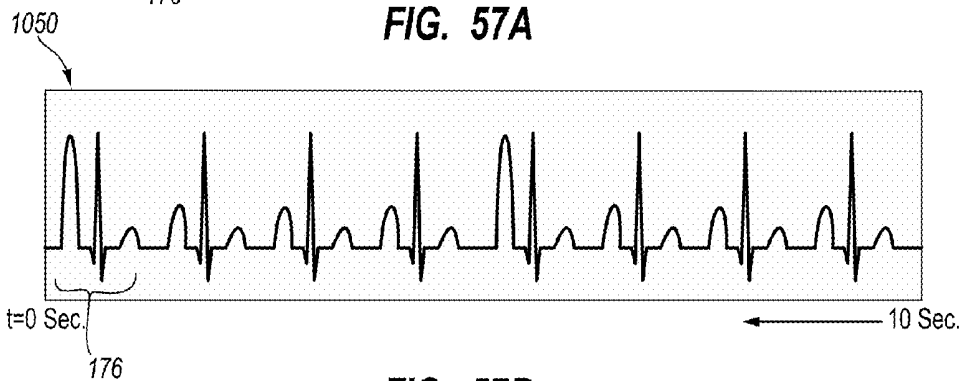

FIG. 57B

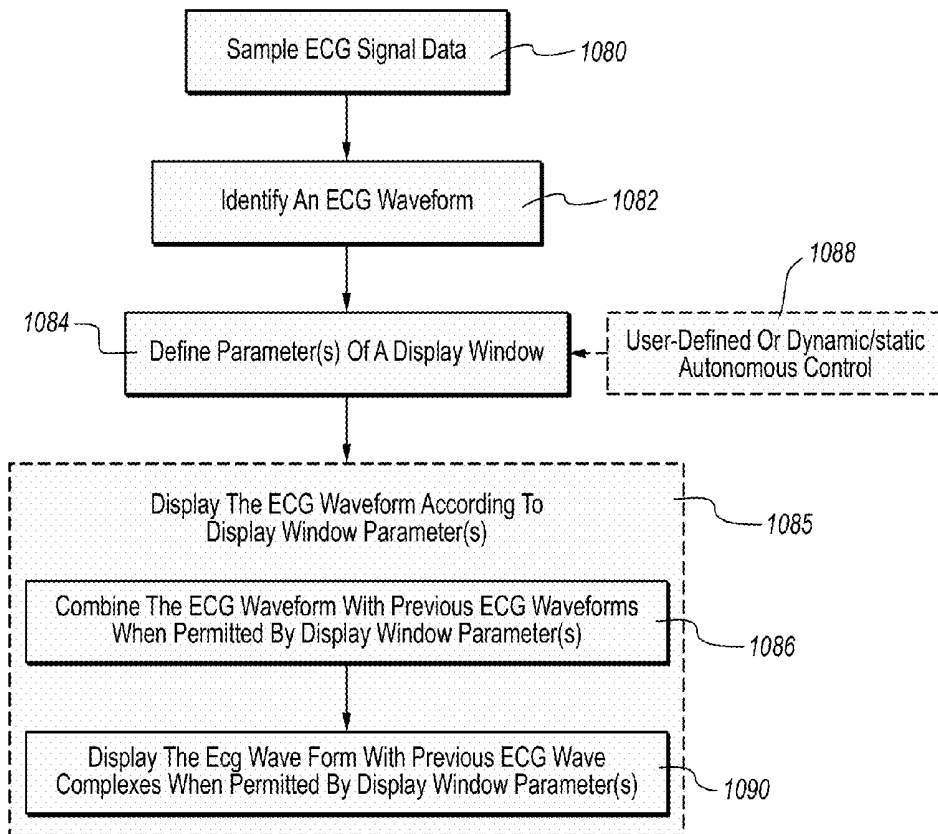

FIG. 58

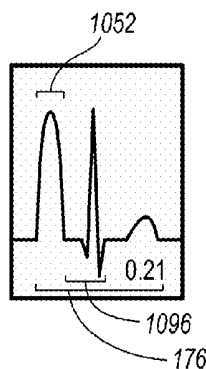

FIG. 59

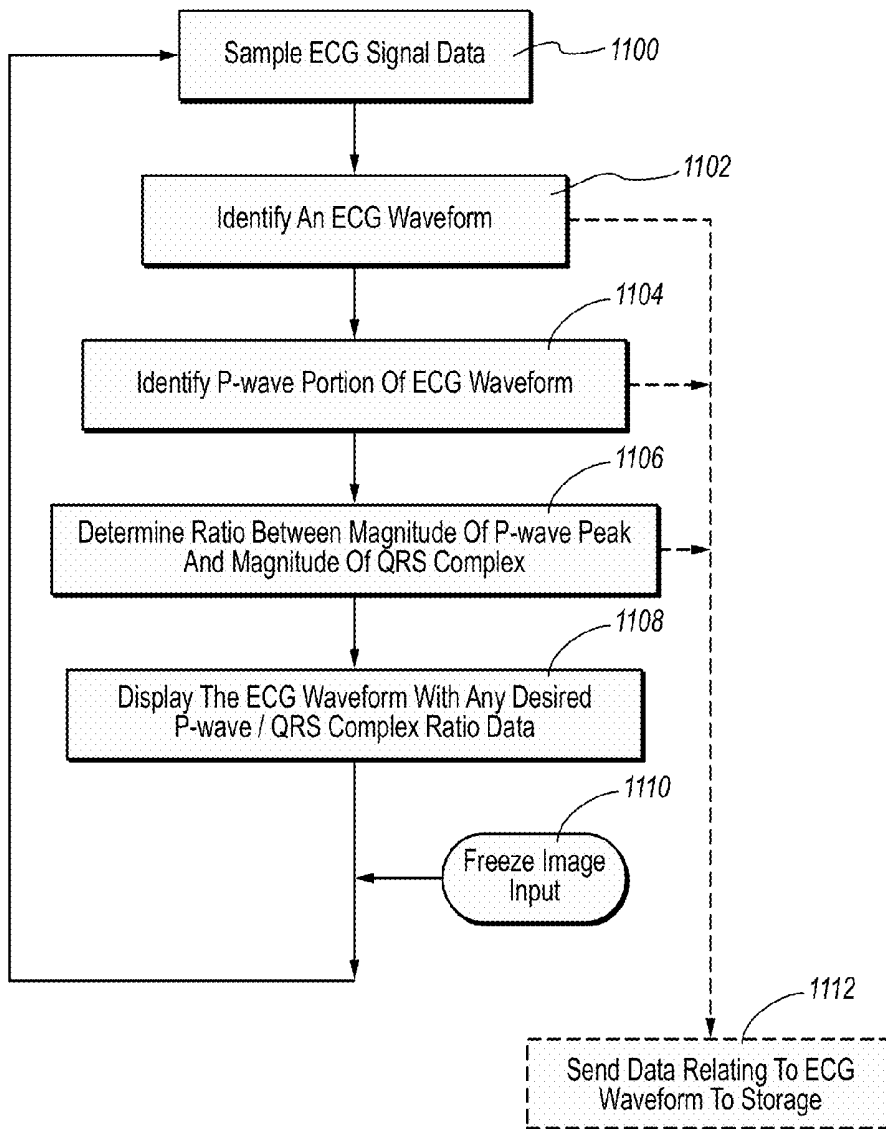

FIG. 60

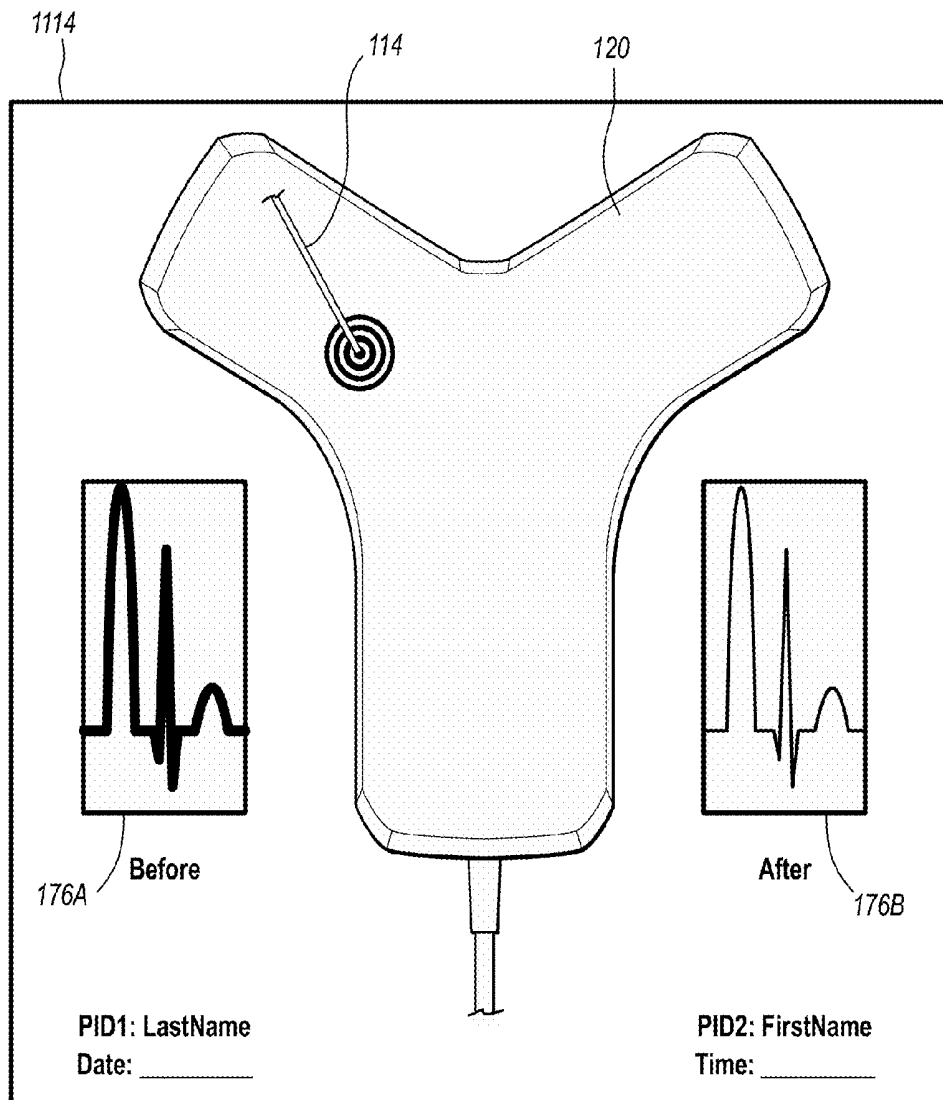

FIG. 61

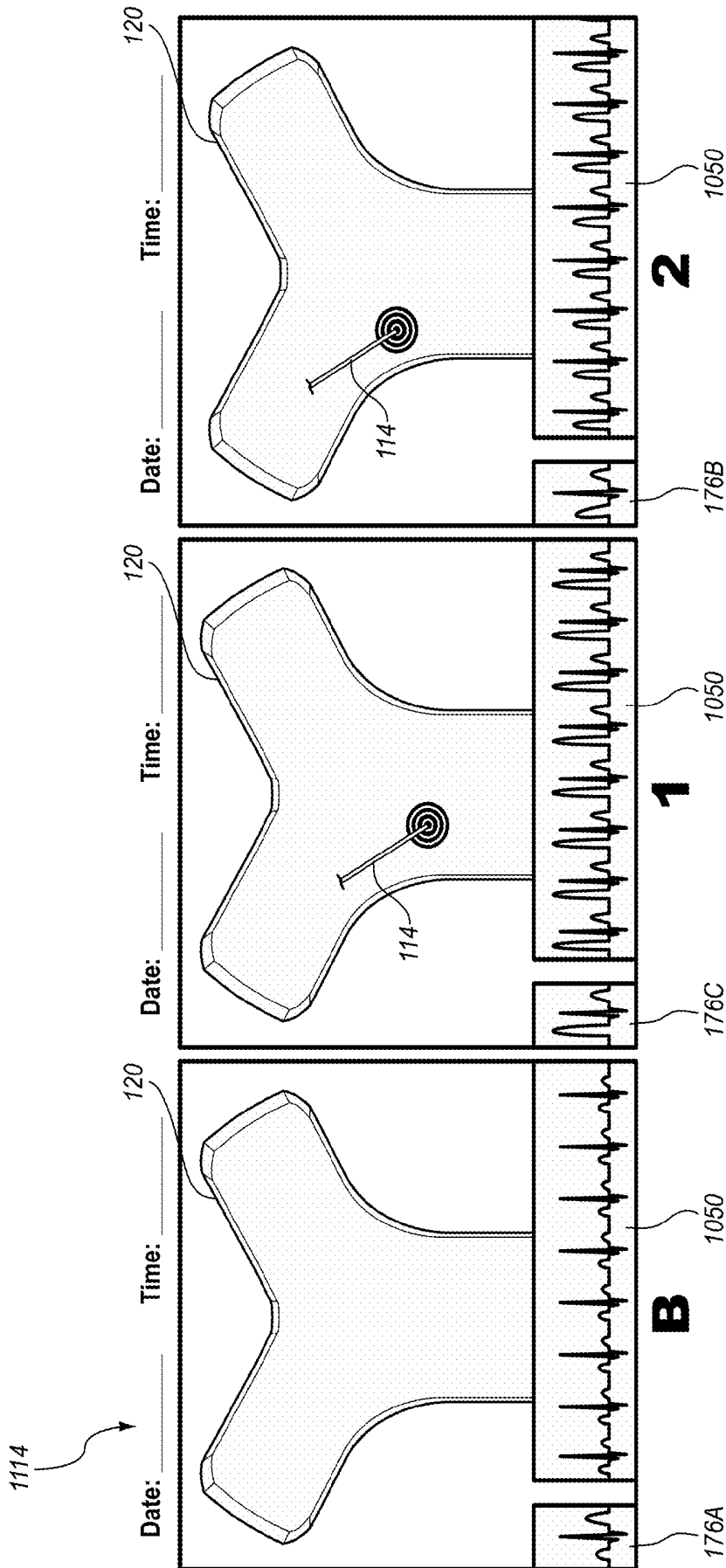

FIG. 62

**APPARATUS AND DISPLAY METHODS
RELATING TO INTRAVASCULAR
PLACEMENT OF A CATHETER**

CROSS-REFERENCE TO RELATED
APPLICATIONS

This application is a division of U.S. patent application Ser. No. 12/557,401, filed Sep. 10, 2009, now U.S. Pat. No. 8,849,382, which claims the benefit of U.S. Provisional Patent Application No. 61/095,921, filed Sep. 10, 2008, and entitled "System and Method for Placing a Catheter Within a Vasculature of a Patient," and which is a continuation-in-part of U.S. application Ser. No. 12/426,175, filed Apr. 17, 2009, and entitled "Systems and Methods for Breaching a Sterile Field for Intravascular Placement of a Catheter," which is a continuation-in-part of U.S. application Ser. No. 12/323,273, filed Nov. 25, 2008, now U.S. Pat. No. 8,388,541, and entitled "Integrated System for Intravascular Placement of a Catheter," which claims the benefit of the following U.S. Provisional Patent Applications: Application No. 60/990,242, filed Nov. 26, 2007, and entitled "Integrated Ultrasound and Tip Location System for Intravascular Placement of a Catheter;" Application No. 61/095,921, filed Sep. 10, 2008, and entitled "System and Method for Placing a Catheter Within a Vasculature of a Patient;" Application No. 61/091,233, filed Aug. 22, 2008, and entitled "Catheter Including Preloaded Steerable Stylet;" Application No. 61/095,451, filed Sep. 9, 2008, and entitled "Catheter Assembly Including ECG and Magnetic-Based Sensor Stylet;" and Application No. 61/045,944, filed Apr. 17, 2008, and entitled "Drape-Breaching Electrical Connector." Each of the afore-referenced applications is incorporated herein by reference in its entirety.

BRIEF SUMMARY

Briefly summarized, embodiments of the present invention are directed to an integrated catheter placement system configured for accurately placing a catheter within the vasculature of a patient. The integrated system employs at least two modalities for improving catheter placement accuracy: 1) ultrasound-assisted guidance for introducing the catheter into the patient's vasculature; and 2) a tip location system ("TLS"), or magnetically-based (e.g., via permanent magnet(s) or electromagnet(s)) tracking of the catheter tip during its advancement through the vasculature to detect and facilitate correction of any tip malposition during such advancement.

In one embodiment, the integrated system comprises a system console including a control processor, a tip location sensor for temporary placement on a portion of a body of the patient, and an ultrasound probe. The tip location sensor senses a magnetic field of a stylet disposed in a lumen of the catheter when the catheter is disposed in the vasculature. The ultrasound probe ultrasonically images a portion of the vasculature prior to introduction of the catheter into the vasculature. In addition, the ultrasound probe includes user input controls for controlling use of the ultrasound probe in an ultrasound mode and use of the tip location sensor in a tip location mode.

In another embodiment, a third modality, i.e., ECG signal-based catheter tip guidance, is included in the system to enable guidance of the catheter tip to a desired position with respect to a node of the patient's heart from which the ECG signals originate. Various means for establishing a conductive pathway between a sterile field of the patient and a

non-sterile field to enable passage of ECG signals from the catheter to the tip location sensor are also disclosed. Such means include, for example, connector schemes that establish the conductive pathway through a perforation defined in a sterile barrier, such as a surgical drape, wherein the perforation is isolated by the connector scheme so as to prevent contamination or compromise of the sterile field of the patient.

In further embodiments, various aspects for visualizing and manipulating display of the ECG signal data acquired via the present catheter placement system are disclosed. These display aspects enable a clinician placing the catheter or other invasive medical device to ascertain information relating to the proximity of the device relative to the ECG signal-emitting node. In yet other embodiments, aspects of various ECG sensor configurations are also disclosed.

These and other features of embodiments of the present invention will become more fully apparent from the following description and appended claims, or may be learned by the practice of embodiments of the invention as set forth hereinafter.

BRIEF DESCRIPTION OF THE DRAWINGS

A more particular description of the present disclosure will be rendered by reference to specific embodiments thereof that are illustrated in the appended drawings. It is appreciated that these drawings depict only typical embodiments of the invention and are therefore not to be considered limiting of its scope. Example embodiments of the invention will be described and explained with additional specificity and detail through the use of the accompanying drawings in which:

FIG. 1 is a block diagram depicting various elements of an integrated system for intravascular placement of a catheter, according to one example embodiment of the present invention;

FIG. 2 is a simplified view of a patient and a catheter being inserted therein with assistance of the integrated system of FIG. 1;

FIGS. 3A and 3B are views of a probe of the integrated system of FIG. 1;

FIG. 4 is a screenshot of an ultrasound image as depicted on a display of the integrated system of FIG. 1;

FIG. 5 is a perspective view of a stylet employed in connection with the system of FIG. 1 in placing a catheter within a patient vasculature;

FIG. 6 is an icon as depicted on a display of the integrated system of FIG. 1, indicating a position of a distal end of the stylet of FIG. 5 during catheter tip placement procedures;

FIGS. 7A-7E depict various example icons that can be depicted on the display of the integrated system of FIG. 1 during catheter tip placement procedures;

FIGS. 8A-8C are screenshots of images depicted on a display of the integrated system of FIG. 1 during catheter tip placement procedures;

FIG. 9 is a block diagram depicting various elements of an integrated system for intravascular placement of a catheter, according to another example embodiment of the present invention;

FIG. 10 is a simplified view of a patient and a catheter being inserted therein with assistance of the integrated system of FIG. 9;

FIG. 11 is a perspective view of a stylet employed in connection with the integrated system of FIG. 9 in placing a catheter within a patient vasculature;

FIGS. 12A-12E are various views of portions of the stylet of FIG. 11;

FIGS. 13A-13D are various views of a fin connector assembly for use with the integrated system of FIG. 9;

FIGS. 13E-13F are various views of a tether connector for use with the fin connector assembly shown in FIGS. 13A-13D;

FIGS. 14A-14C are views showing the connection of a stylet tether and fin connector to a sensor of the integrated system of FIG. 9;

FIG. 15 is a cross sectional view of the connection of the stylet tether, fin connector, and sensor shown in FIG. 14C;

FIG. 16 is simplified view of an ECG trace of a patient;

FIG. 17 is a screenshot of an image depicted on a display of the integrated system of FIG. 9 during catheter tip placement procedures;

FIG. 18 is a cross sectional view of a fin connector including electrical contacts configured in accordance with one embodiment;

FIGS. 19A and 19B are simplified views of an electrical contact retention system for engagement of a tether connector with a fin connector, in accordance with one embodiment;

FIGS. 20A-20C are various views of one embodiment of a fin connector and a tether connector for establishing a signal pathway through a sterile barrier in connection with use of the integrated system described herein;

FIGS. 21A and 21B are various views of a connector for electrically connecting ECG electrodes to a sensor of the integrated system, according to one embodiment;

FIGS. 22A-22C are various views of one embodiment of a fin connector and a tether connector for establishing a signal pathway through a sterile barrier;

FIGS. 23A and 23B are cross sectional views of a connector system for establishing a signal pathway through a sterile barrier, according to one embodiment;

FIG. 24 is a simplified side view of a connector system for establishing a signal pathway through a sterile barrier, according to one embodiment;

FIGS. 25A and 25B are simplified side views of a connector system for establishing a signal pathway through a sterile barrier, according to one embodiment;

FIGS. 26A and 26B are cross sectional views of a connector system for establishing a signal pathway through a sterile barrier, according to one embodiment;

FIG. 27 is a simplified view of a connector system for establishing a signal pathway through a sterile barrier, according to one embodiment;

FIG. 28 is a perspective view of stylet including a sterile shield for use with the connector system shown in FIG. 28, according to one embodiment;

FIGS. 29A and 29B are simplified views of the ECG module of FIG. 27, including a connector system for establishing a signal pathway through a sterile barrier, according to one embodiment;

FIG. 30 is a simplified view of a connector system for establishing a signal pathway through a sterile barrier, according to one embodiment;

FIG. 31 is a simplified view of a connector system for establishing a signal pathway through a sterile barrier, according to one embodiment;

FIG. 32 is a simplified view of elements of a connector system for establishing a signal pathway through a sterile barrier, according to one embodiment;

FIG. 33 is a view of a means for establishing a conductive pathway between sterile and non-sterile fields, according to one embodiment;

FIG. 34 is a view of another means for establishing a conductive pathway between sterile and non-sterile fields, according to one embodiment;

FIGS. 35A-C depict exemplary P-wave waveforms;

FIG. 36 is a view of a sensor retro-fitted with a wireless module, according to one embodiment;

FIG. 37 is a view of a retention feature for a connector, according to one embodiment;

FIG. 38 is a perspective view of a catheter including an ECG sensor according to one embodiment;

FIG. 39 is a perspective view of a sensor assembly including multiple electrodes disposed on a catheter;

FIGS. 40A-40C depict operation of the catheter of FIG. 39;

FIGS. 41A-41D are various views of an electrode connection integrity indicator and system in accordance with one embodiment;

FIG. 42 is a perspective view of an electrode connection integrity system according to one embodiment;

FIGS. 43A and 43B are cross sectional views of a stylet including a conductive wire loop for detecting severing of the stylet according to one embodiment;

FIG. 44 is a partial cross sectional view the stylet of FIG. 43A, including a conductive wire loop with a planar wire in accordance with one embodiment;

FIG. 45 is a cross sectional view of a catheter including a stylet with a distal interference feature according to one embodiment;

FIG. 46 is a cross sectional view of a catheter including a stylet with a distal interference feature according to another embodiment;

FIGS. 47A and 47B are cross sectional views of distal portions of a catheter and stylet configured to maintain alignment of the distal ends of the catheter and stylet according to one embodiment.

FIG. 48 is a perspective view of an external dual-ECG electrode assembly in accordance with one embodiment;

FIG. 49 is a perspective view of an external ECG electrode assembly including graphics in accordance with one embodiment;

FIG. 50 is an ECG trace showing P-wave characteristics according to one embodiment;

FIG. 51 is a flow chart describing one method according to one embodiment;

FIGS. 52-55 are ECG traces showing additional P-wave characteristics according to embodiments of the present disclosure;

FIGS. 56A-57B are ECG traces showing details regarding ECG waveform scaling according to one embodiment;

FIG. 58 is a flow chart describing one method according to one embodiment;

FIG. 59 is a display window including aspects of a single ECG waveform according to one embodiment;

FIG. 60 is a flow chart describing one method according to one embodiment;

FIG. 61 is a catheter placement record configured according to one embodiment; and

FIG. 62 is another catheter placement record configured according to one embodiment.

DETAILED DESCRIPTION OF SELECTED EMBODIMENTS

Reference will now be made to figures wherein like structures will be provided with like reference designations. It is understood that the drawings are diagrammatic and

schematic representations of exemplary embodiments of the present invention, and are neither limiting nor necessarily drawn to scale.

FIGS. 1-62 depict various features of embodiments of the present invention, which is generally directed to a catheter placement system configured for accurately placing a catheter within the vasculature of a patient. In one embodiment, the catheter placement system employs at least two modalities for improving catheter placement accuracy: 1) ultrasound-assisted guidance for introducing the catheter into the patient's vasculature; and 2) a tip location/navigation system ("TLS"), or magnetically-based tracking of the catheter tip during its advancement through the tortuous vasculature path to detect and facilitate correction of any tip malposition during such advancement. The ultrasound guidance and tip location features of the present system according to one embodiment are integrated into a single device for use by a clinician placing the catheter. Integration of these two modalities into a single device simplifies the catheter placement process and results in relatively faster catheter placements. For instance, the integrated catheter placement system enables ultrasound and TLS activities to be viewed from a single display of the integrated system. Also, controls located on an ultrasound probe of the integrated device, which probe is maintained within the sterile field of the patient during catheter placement, can be used to control functionality of the system, thus precluding the need for a clinician to reach out of the sterile field in order to control the system.

In another embodiment, a third modality, i.e., ECG signal-based catheter tip guidance, is included in the integrated system to enable guidance of the catheter tip to a desired position with respect to a node of the patient's heart from which the ECG signals originate. Such ECG-based positional assistance is also referred to herein as "tip confirmation."

Combination of the three modalities above according to one embodiment enables the catheter placement system to facilitate catheter placement within the patient's vasculature with a relatively high level of accuracy, i.e., placement of the distal tip of the catheter in a predetermined and desired position. Moreover, because of the ECG-based guidance of the catheter tip, correct tip placement may be confirmed without the need for a confirmatory X-ray. This, in turn, reduces the patient's exposure to potentially harmful x-rays, the cost and time involved in transporting the patient to and from the x-ray department, costly and inconvenient catheter repositioning procedures, etc.

As the ECG signal-based modality includes a need for passing ECG signals from a catheter assembly disposed in a sterile field of a patient to a data-receiving component of the system disposed in a non-sterile field, embodiments of the present invention are further concerned with various connector systems for establishing a conductive pathway through a sterile barrier separating the sterile and non-sterile fields. Various aspects for visualizing and manipulating display of the ECG signal data acquired via the present system, together with aspects of various ECG sensor configurations, are also disclosed.

For clarity it is to be understood that the word "proximal" as used herein refers to a direction relatively closer to a clinician, while the word "distal" refers to a direction relatively further from the clinician. For example, the end of a catheter placed within the body of a patient is considered a distal end of the catheter, while the catheter end remaining outside the body is a proximal end of the catheter. Also, the

words "including," "has," and "having," as used herein, including the claims, shall have the same meaning as the word "comprising."

Reference is first made to FIGS. 1 and 2 which depict various components of a catheter placement system ("system"), generally designated at 10, configured in accordance with one example embodiment of the present invention. As shown, the system 10 generally includes a console 20, display 30, probe 40, and sensor 50, each of which is described in further detail below.

FIG. 2 shows the general relation of these components to a patient 70 during a procedure to place a catheter 72 into the patient vasculature through a skin insertion site 73. FIG. 2 shows that the catheter 72 generally includes a proximal portion 74 that remains exterior to the patient and a distal portion 76 that resides within the patient vasculature after placement is complete. The system 10 is employed to ultimately position a distal tip 76A of the catheter 72 in a desired position within the patient vasculature. In one embodiment, the desired position for the catheter distal tip 76A is proximate the patient's heart, such as in the lower one-third ($1/3^{rd}$) portion of the Superior Vena Cava ("SVC"). Of course, the system 10 can be employed to place the catheter distal tip in other locations. The catheter proximal portion 74 further includes a hub 74A that provides fluid communication between the one or more lumens of the catheter 72 and one or more extension legs 74B extending proximally from the hub.

An example implementation of the console 20 is shown in FIG. 8C, though it is appreciated that the console can take one of a variety of forms. A processor 22, including non-volatile memory such as EEPROM for instance, is included in the console 20 for controlling system function during operation of the system 10, thus acting as a control processor. A digital controller/analog interface 24 is also included with the console 20 and is in communication with both the processor 22 and other system components to govern interfacing between the probe 40, sensor 50, and other system components.

The system 10 further includes ports 52 for connection with the sensor 50 and optional components 54 including a printer, storage media, keyboard, etc. The ports in one embodiment are USB ports, though other port types or a combination of port types can be used for this and the other interfaces connections described herein. A power connection 56 is included with the console 20 to enable operable connection to an external power supply 58. An internal battery 60 can also be employed, either with or exclusive of an external power supply. Power management circuitry 59 is included with the digital controller/analog interface 24 of the console to regulate power use and distribution.

The display 30 in the present embodiment is integrated into the console 20 and is used to display information to the clinician during the catheter placement procedure. In another embodiment, the display may be separate from the console. As will be seen, the content depicted by the display 30 changes according to which mode the catheter placement system is in: US, TLS, or in other embodiments, ECG tip confirmation. In one embodiment, a console button interface 32 (see FIGS. 1, 8C) and buttons included on the probe 40 can be used to immediately call up a desired mode to the display 30 by the clinician to assist in the placement procedure. In one embodiment, information from multiple modes, such as TLS and ECG, may be displayed simultaneously, such as in FIG. 17. Thus, the single display 30 of the system console 20 can be employed for ultrasound guidance in accessing a patient's vasculature, TLS guidance

during catheter advancement through the vasculature, and (as in later embodiments) ECG-based confirmation of catheter distal tip placement with respect to a node of the patient's heart. In one embodiment, the display 30 is an LCD device.

FIGS. 3A and 3B depict features of the probe 40 according to one embodiment. The probe 40 is employed in connection with the first modality mentioned above, i.e., ultrasound ("US")-based visualization of a vessel, such as a vein, in preparation for insertion of the catheter 72 into the vasculature. Such visualization gives real time ultrasound guidance for introducing the catheter into the vasculature of the patient and assists in reducing complications typically associated with such introduction, including inadvertent arterial puncture, hematoma, pneumothorax, etc.

The handheld probe 40 includes a head 80 that houses a piezoelectric array for producing ultrasonic pulses and for receiving echoes thereof after reflection by the patient's body when the head is placed against the patient's skin proximate the prospective insertion site 73 (FIG. 2). The probe 40 further includes a plurality of control buttons 84, which can be included on a button pad 82. In the present embodiment, the modality of the system 10 can be controlled by the control buttons 84, thus eliminating the need for the clinician to reach out of the sterile field, which is established about the patient insertion site prior to catheter placement, to change modes via use of the console button interface 32.

As such, in one embodiment a clinician employs the first (US) modality to determine a suitable insertion site and establish vascular access, such as with a needle or introducer, then with the catheter. The clinician can then seamlessly switch, via button pushes on the probe button pad 82, to the second (TLS) modality without having to reach out of the sterile field. The TLS mode can then be used to assist in advancement of the catheter 72 through the vasculature toward an intended destination.

FIG. 1 shows that the probe 40 further includes button and memory controller 42 for governing button and probe operation. The button and memory controller 42 can include non-volatile memory, such as EEPROM, in one embodiment. The button and memory controller 42 is in operable communication with a probe interface 44 of the console 20, which includes a piezo input/output component 44A for interfacing with the probe piezoelectric array and a button and memory input/output component 44B for interfacing with the button and memory controller 42.

FIG. 4 shows an example screenshot 88 as depicted on the display 30 while the system 10 is in its first ultrasound modality. An image 90 of a subcutaneous region of the patient 70 is shown, depicting a cross section of a vein 92. The image 90 is produced by operation of the piezoelectric array of the probe 40. Also included on the display screenshot 88 is a depth scale indicator 94, providing information regarding the depth of the image 90 below the patient's skin, a lumen size scale 96 that provides information as to the size of the vein 92 relative to standard catheter lumen sizes, and other indicia 98 that provide information regarding status of the system 10 or possible actions to be taken, e.g., freeze frame, image templates, data save, image print, power status, image brightness, etc.

Note that while a vein is depicted in the image 90, other body lumens or portions can be imaged in other embodiments. Note that the US mode shown in FIG. 4 can be simultaneously depicted on the display 30 with other modes, such as the TLS mode, if desired. In addition to the visual display 30, aural information, such as beeps, tones, etc., can

also be employed by the system 10 to assist the clinician during catheter placement. Moreover, the buttons included on the probe 40 and the console button interface 32 can be configured in a variety of ways, including the use of user input controls in addition to buttons, such as slide switches, toggle switches, electronic or touch-sensitive pads, etc. Additionally, both US and TLS activities can occur simultaneously or exclusively during use of the system 10.

As just described, the handheld ultrasound probe 40 is employed as part of the integrated catheter placement system 10 to enable US visualization of the peripheral vasculature of a patient in preparation for transcutaneous introduction of the catheter. In the present example embodiment, however, the probe is also employed to control functionality of the TLS portion, or second modality, of the system 10 when navigating the catheter toward its desired destination within the vasculature as described below. Again, as the probe 40 is used within the sterile field of the patient, this feature enables TLS functionality to be controlled entirely from within the sterile field. Thus the probe 40 is a dual-purpose device, enabling convenient control of both US and TLS functionality of the system 10 from the sterile field. In one embodiment, the probe can also be employed to control some or all ECG-related functionality, or third modality, of the catheter placement system 10, as described further below.

The catheter placement system 10 further includes the second modality mentioned above, i.e., the magnetically-based catheter TLS, or tip location system. The TLS enables the clinician to quickly locate and confirm the position and/or orientation of the catheter 72, such as a peripherally-inserted central catheter ("PICC"), central venous catheter ("CVC"), or other suitable catheter, during initial placement into and advancement through the vasculature of the patient 70. Specifically, the TLS modality detects a magnetic field generated by a magnetic element-equipped tip location stylet, which is pre-loaded in one embodiment into a longitudinally defined lumen of the catheter 72, thus enabling the clinician to ascertain the general location and orientation of the catheter tip within the patient body. In one embodiment, the magnetic assembly can be tracked using the teachings of one or more of the following U.S. Pat. Nos. 5,775,322; 5,879,297; 6,129,668; 6,216,028; and 6,263,230. The contents of the afore-mentioned U.S. patents are incorporated herein by reference in their entireties. The TLS also displays the direction in which the catheter tip is pointing, thus further assisting accurate catheter placement. The TLS further assists the clinician in determining when a malposition of the catheter tip has occurred, such as in the case where the tip has deviated from a desired venous path into another vein.

As mentioned, the TLS utilizes a stylet to enable the distal end of the catheter 72 to be tracked during its advancement through the vasculature. FIG. 5 gives an example of such a stylet 100, which includes a proximal end 100A and a distal end 100B. A handle is included at the stylet proximal end 100A, with a core wire 104 extending distally therefrom. A magnetic assembly is disposed distally of the core wire 104. The magnetic assembly includes one or more magnetic elements 106 disposed adjacent one another proximate the stylet distal end 100B and encapsulated by tubing 108. In the present embodiment, a plurality of magnetic elements 106 is included, each element including a solid, cylindrically shaped ferromagnetic stacked end-to-end with the other magnetic elements. An adhesive tip 110 can fill the distal tip of the tubing 108, distally to the magnetic elements 106.

Note that in other embodiments, the magnetic elements may vary from the design in not only shape, but also composition, number, size, magnetic type, and position in the stylet distal segment. For example, in one embodiment, the plurality of ferromagnetic magnetic elements is replaced with an electromagnetic assembly, such as an electromagnetic coil, which produces a magnetic field for detection by the sensor. Another example of an assembly usable here can be found in U.S. Pat. No. 5,099,845 entitled "Medical Instrument Location Means," which is incorporated herein by reference in its entirety. Yet other examples of stylets including magnetic elements that can be employed with the TLS modality can be found in U.S. Pat. No. 8,784,336, entitled "Stylet Apparatuses and Methods of Manufacture," which is incorporated herein by reference in its entirety. These and other variations are therefore contemplated by embodiments of the present invention. It should be appreciated herein that "stylet" as used herein can include any one of a variety of devices configured for removable placement within a lumen of the catheter to assist in placing a distal end of the catheter in a desired location within the patient's vasculature.

FIG. 2 shows disposal of the stylet 100 substantially within a lumen in the catheter 72 such that the proximal portion thereof extends proximally from the catheter lumen, through the hub 74A and out through a selected one of the extension legs 74B. So disposed within a lumen of the catheter, the distal end 100B of the stylet 100 is substantially co-terminal with the distal catheter end 76A such that detection by the TLS of the stylet distal end correspondingly indicates the location of the catheter distal end.

The TLS sensor 50 is employed by the system 10 during TLS operation to detect a magnetic field produced by the magnetic elements 106 of the stylet 100. As seen in FIG. 2, the TLS sensor 50 is placed on the chest of the patient during catheter insertion. The TLS sensor 50 is placed on the chest of the patient in a predetermined location, such as through the use of external body landmarks, to enable the magnetic field of the stylet magnetic elements 106, disposed in the catheter 72 as described above, to be detected during catheter transit through the patient vasculature. Again, as the magnetic elements 106 of the stylet magnetic assembly are co-terminal with the distal end 76A of the catheter 72 (FIG. 2), detection by the TLS sensor 50 of the magnetic field of the magnetic elements provides information to the clinician as to the position and orientation of the catheter distal end during its transit.

In greater detail, the TLS sensor 50 is operably connected to the console 20 of the system 10 via one or more of the ports 52, as shown in FIG. 1. Note that other connection schemes between the TLS sensor and the system console can also be used without limitation. As just described, the magnetic elements 106 are employed in the stylet 100 to enable the position of the catheter distal end 76A (FIG. 2) to be observable relative to the TLS sensor 50 placed on the patient's chest. Detection by the TLS sensor 50 of the stylet magnetic elements 106 is graphically displayed on the display 30 of the console 20 during TLS mode. In this way, a clinician placing the catheter is able to generally determine the location of the catheter distal end 76A within the patient vasculature relative to the TLS sensor 50 and detect when catheter malposition, such as advancement of the catheter along an undesired vein, is occurring.

FIGS. 6 and 7A-7E show examples of icons that can be used by the console display 30 to depict detection of the stylet magnetic elements 106 by the TLS sensor 50. In particular, FIG. 6 shows an icon 114 that depicts the distal

portion of the stylet 100, including the magnetic elements 106 as detected by the TLS sensor 50 when the magnetic elements are positioned under the TLS sensor. As the stylet distal end 100B is substantially co-terminal with the distal end 76A of the catheter 72, the icon indicates the position and orientation of the catheter distal end. FIGS. 7A-7E show various icons that can be depicted on the console display 30 when the magnetic elements 106 of the stylet 100 are not positioned directly under a portion of the TLS sensor 50, but are nonetheless detected nearby. The icons can include half-icons 114A and quarter-icons 114B that are displayed according to the position of the stylet magnetic assembly, i.e., the magnetic elements 106 in the present embodiment, relative to the TLS sensor 50.

FIGS. 8A-8C depict screenshots taken from the display 30 of the system 10 while in TLS mode, showing how the magnetic assembly of the stylet 100 is depicted. The screenshot 118 of FIG. 8A shows a representative image 120 of the TLS sensor 50. Other information is provided on the display screenshot 118, including a depth scale indicator 124, status/action indicia 126, and icons 128 corresponding to the button interface 32 included on the console 20 (FIG. 8C). Though the icons 128 in the present embodiment are simply indicators to guide the user in identifying the purpose of the corresponding buttons of the button interface 32, in another embodiment the display can be made touch-sensitive so that the icons themselves can function as button interfaces and can change according to the mode the system is in.

During initial stages of catheter advancement through the patient's vasculature after insertion therein, the distal end 76A of the catheter 72, having the stylet distal end 100B substantially co-terminal therewith, is relatively distant from the TLS sensor 50. As such, the display screenshot will indicate "no signal," indicating that the magnetic field from the stylet magnetic assembly has not been detected. In FIG. 8B, the magnetic assembly proximate the stylet distal end 100B has advanced sufficiently close to the TLS sensor 50 to be detected thereby, though it is not yet under the sensor. This is indicated by the half-icon 114A shown to the left of the sensor image 120, representing the stylet magnetic assembly being positioned to the right of the TLS sensor 50 from the perspective of the patient.

In FIG. 8C, the magnetic assembly proximate the stylet distal end 100B has advanced under the TLS sensor 50 such that its position and orientation relative thereto is detected by the TLS sensor. This is indicated by the icon 114 on the sensor image 120. Note that the button icons 128 provide indications of the actions that can be performed by pressing the corresponding buttons of the console button interface 32. As such, the button icons 128 can change according to which modality the system 10 is in, thus providing flexibility of use for the button interface 32. Note further that, as the button pad 82 of the probe 40 (FIG. 3A, 3B) includes buttons 84 that mimic several of the buttons of the button interface 32, the button icons 128 on the display 30 provide a guide to the clinician for controlling the system 10 with the probe buttons 84 while remaining in the sterile field. For instance, if the clinician has need to leave TLS mode and return to US (ultrasound) mode, the appropriate control button 84 on the probe button pad 82 can be depressed, and the US mode can be immediately called up, with the display 30 refreshing to accommodate the visual information needed for US functionality, such as that shown in FIG. 4. This is accomplished without a need for the clinician to reach out of the sterile field.

Reference is now made to FIGS. 9 and 10 in describing the integrated catheter placement system 10 according to

another example embodiment. As before, the integrated system 10 includes the console 20, display 30, probe 40 for US functionality, and the TLS sensor 50 for tip location functionality as described above. Note that the system 10 depicted in FIGS. 9 and 10 is similar in many respects to the system shown in FIGS. 1 and 2. As such, only selected differences will be discussed below. The system 10 of FIGS. 9 and 10 includes additional functionality wherein determination of the proximity of the catheter distal tip 76A relative to a sino-atrial (“SA”) or other electrical impulse-emitting node of the heart of the patient 70 can be determined, thus providing enhanced ability to accurately place the catheter distal tip in a desired location proximate the node. Also referred to herein as “ECG” or “ECG-based tip confirmation,” this third modality of the system 10 enables detection of ECG signals from the SA node in order to place the catheter distal tip in a desired location within the patient vasculature. Note that the US, TLS, and ECG modalities are seamlessly combined in the present system 10, but can be employed in concert or individually to assist in catheter placement. In one embodiment, it is understood that the ECG modality as described herein can be included in a stand-alone system without the inclusion of the US and TLS modalities. Thus, the environments in which the embodiments herein are described are understood as merely example environments and are not considered limiting of the present disclosure.

FIGS. 9 and 10 show the addition to the system 10 of a stylet 130 configured in accordance with the present embodiment. As an overview, the catheter stylet 130 is removably predisposed within the lumen of the catheter 72 being inserted into the patient 70 via the insertion site 73. The stylet 130, in addition to including a magnetic assembly for the magnetically-based TLS modality, includes a sensing component, i.e., an ECG sensor assembly, proximate its distal end and including a portion that is co-terminal with the distal end of the catheter tip for sensing ECG signals produced by the SA node. In contrast to the previous embodiment, the stylet 130 includes a tether 134 extending from its proximal end that operably connects to the TLS sensor 50. As will be described in further detail, the stylet tether 134 permits ECG signals detected by the ECG sensor assembly included on a distal portion of the stylet 130 to be conveyed to the TLS sensor 50 during confirmation of the catheter tip location as part of the ECG signal-based tip confirmation modality. Reference and ground ECG lead/electrode pairs 158 attach to the body of the body of the patient 70 and are operably attached to the TLS sensor 50 to enable the system to filter out high level electrical activity unrelated to the electrical activity of the SA node of the heart, thus enabling the ECG-based tip confirmation functionality. Together with the reference and ground signals received from the ECG lead/electrode pairs 158 placed on the patient’s skin, the ECG signals sensed by the stylet ECG sensor assembly are received by the TLS sensor 50 positioned on the patient’s chest (FIG. 10) or other designated component of the system 10. The TLS sensor 50 and/or console processor 22 can process the ECG signal data to produce an electrocardiogram waveform on the display 30, as will be described. In the case where the TLS sensor 50 processes the ECG signal data, a processor is included therein to perform the intended functionality. If the console 20 processes the ECG signal data, the processor 22, controller 24, or other processor can be utilized in the console to process the data.

Thus, as it is advanced through the patient vasculature, the catheter 72 equipped with the stylet 130 as described above

can advance under the TLS sensor 50, which is positioned on the chest of the patient as shown in FIG. 10. This enables the TLS sensor 50 to detect the position of the magnetic assembly of the stylet 130, which is substantially co-terminal with the distal tip 76A of the catheter as located within the patient’s vasculature. The detection by the TLS sensor 50 of the stylet magnetic assembly is depicted on the display 30 during ECG mode. The display 30 further depicts during ECG mode an ECG electrocardiogram waveform produced as a result of patient heart’s electrical activity as detected by the ECG sensor assembly of the stylet 130. In greater detail, the ECG electrical activity of the SA node, including the P-wave of the waveform, is detected by the ECG sensor assembly of the stylet (described below) and forwarded to the TLS sensor 50 and console 20. The ECG electrical activity is then processed for depiction on the display 30. A clinician placing the catheter can then observe the ECG data to determine optimum placement of the distal tip 76A of the catheter 72, such as proximate the SA node in one embodiment. In one embodiment, the console 20 includes the electronic components, such as the processor 22 (FIG. 9), necessary to receive and process the signals detected by the stylet ECG sensor assembly. In another embodiment, the TLS sensor 50 can include the necessary electronic components processing the ECG signals.

As already discussed, the display 30 is used to display information to the clinician during the catheter placement procedure. The content of the display 30 changes according to which mode the catheter placement system is in: US, TLS, or ECG. Any of the three modes can be immediately called up to the display 30 by the clinician, and in some cases information from multiple modes, such as TLS and ECG, may be displayed simultaneously. In one embodiment, as before, the mode the system is in may be controlled by the control buttons 84 included on the handheld probe 40, thus eliminating the need for the clinician to reach out of the sterile field (such as touching the button interface 32 of the console 20) to change modes. Thus, in the present embodiment the probe 40 is employed to also control some or all ECG-related functionality of the system 10. Note that the button interface 32 or other input configurations can also be used to control system functionality. Also, in addition to the visual display 30, aural information, such as beeps, tones, etc., can also be employed by the system to assist the clinician during catheter placement.

Reference is now made to FIGS. 11-12E in describing various details of one embodiment of the stylet 130 that is removably loaded into the catheter 72 and employed during insertion to position the distal tip 76A of the catheter in a desired location within the patient vasculature. As shown, the stylet 130 as removed from the catheter defines a proximal end 130A and a distal end 130B. A connector 132 is included at the proximal stylet end 130A, and a tether 134 extends distally from the connector and attaches to a handle 136. A core wire 138 extends distally from the handle 136. The stylet 130 is pre-loaded within a lumen of the catheter 72 in one embodiment such that the distal end 130B is substantially flush, or co-terminal, with the catheter opening at the distal end 76A thereof (FIG. 10), and such that a proximal portion of the core wire 138, the handle 136, and the tether 134 extend proximally from a selected one of the extension tubes 74B. Note that, though described herein as a stylet, in other embodiments a guidewire or other catheter guiding apparatus could include the principles of the embodiment described herein.

The core wire 138 defines an elongate shape and is composed of a suitable stylet material including stainless

steel or a memory material such as, in one embodiment, a nickel and titanium-containing alloy commonly known by the acronym "nitinol." Though not shown here, manufacture of the core wire **138** from nitinol in one embodiment enables the portion of the core wire corresponding to a distal segment of the stylet to have a pre-shaped bent configuration so as to urge the distal portion of the catheter **72** into a similar bent configuration. In other embodiments, the core wire includes no pre-shaping. Further, the nitinol construction lends torqueability to the core wire **138** to enable a distal segment of the stylet **130** to be manipulated while disposed within the lumen of the catheter **72**, which in turn enables the distal portion of the catheter to be navigated through the vasculature during catheter insertion.

The handle **136** is provided to enable insertion/removal of the stylet from the catheter **72**. In embodiments where the stylet core wire **138** is torqueable, the handle **136** further enables the core wire to be rotated within the lumen of the catheter **72**, to assist in navigating the catheter distal portion through the vasculature of the patient **70**.

The handle **136** attaches to a distal end of the tether **134**. In the present embodiment, the tether **134** is a flexible, shielded cable housing one or more conductive wires electrically connected both to the core wire **138**, which acts as the ECG sensor assembly referred to above, and the tether connector **132**. As such, the tether **134** provides a conductive pathway from the distal portion of the core wire **138** through to the tether connector **132** at proximal end **130A** of the stylet **130**. As will be explained, the tether connector **132** is configured for operable connection to the TLS sensor **50** on the patient's chest for assisting in navigation of the catheter distal tip **76A** to a desired location within the patient vasculature.

As seen in FIGS. **12B-12D**, a distal portion of the core wire **138** is gradually tapered, or reduced in diameter, distally from a junction point **142**. A sleeve **140** is slid over the reduced-diameter core wire portion. Though of relatively greater diameter here, the sleeve in another embodiment can be sized to substantially match the diameter of the proximal portion of the stylet core wire. The stylet **130** further includes a magnetic assembly disposed proximate the distal end **130B** thereof for use during TLS mode. The magnetic assembly in the illustrated embodiment includes a plurality of magnetic elements **144** interposed between an outer surface of the reduced-diameter core wire **138** and an inner surface of the sleeve **140** proximate the stylet distal end **130B**. In the present embodiment, the magnetic elements **144** include 20 ferromagnetic magnets of a solid cylindrical shape stacked end-to-end in a manner similar to the stylet **100** of FIG. **2**. In other embodiments, however, the magnetic element(s) may vary from this design in not only shape, but also composition, number, size, magnetic type, and position in the stylet. For example, in one embodiment the plurality of magnets of the magnetic assembly is replaced with an electromagnetic coil that produces a magnetic field for detection by the TLS sensor. These and other variations are therefore contemplated by embodiments of the present invention.

The magnetic elements **144** are employed in the stylet **130** distal portion to enable the position of the stylet distal end **130B** to be observable relative to the TLS sensor **50** placed on the patient's chest. As has been mentioned, the TLS sensor **50** is configured to detect the magnetic field of the magnetic elements **144** as the stylet advances with the catheter **72** through the patient vasculature. In this way, a clinician placing the catheter **72** is able to generally determine the location of the catheter distal end **76A** within the

patient vasculature and detect when catheter malposition is occurring, such as advancement of the catheter along an undesired vein, for instance.

The stylet **130** further includes the afore-mentioned ECG sensor assembly, according to one embodiment. The ECG sensor assembly enables the stylet **130**, disposed in a lumen of the catheter **72** during insertion, to be employed in detecting an intra-atrial ECG signal produced by an SA or other node of the patient's heart, thereby allowing for navigation of the distal tip **76A** of the catheter **72** to a predetermined location within the vasculature proximate the patient's heart. Thus, the ECG sensor assembly serves as an aide in confirming proper placement of the catheter distal tip **76A**.

In the embodiment illustrated in FIGS. **11-12E**, the ECG sensor assembly includes a distal portion of the core wire **138** disposed proximate the stylet distal end **130B**. The core wire **138**, being electrically conductive, enables ECG signals to be detected by the distal end thereof and transmitted proximally along the core wire. A conductive material **146**, such as a conductive epoxy, fills a distal portion of the sleeve **140** adjacent the distal termination of the core wire **138** so as to be in conductive communication with the distal end of the core wire. This in turn increases the conductive surface of the distal end **130B** of the stylet **130** so as to improve its ability to detect ECG signals.

Before catheter placement, the stylet **130** is loaded into a lumen of the catheter **72**. Note that the stylet **130** can come preloaded in the catheter lumen from the manufacturer, or loaded into the catheter by the clinician prior to catheter insertion. The stylet **130** is disposed within the catheter lumen such that the distal end **130B** of the stylet **130** is substantially co-terminal with the distal tip **76A** of the catheter **72**, thus placing the distal tips of both the stylet and the catheter in substantial alignment with one another. The co-terminality of the catheter **72** and stylet **130** enables the magnetic assembly to function with the TLS sensor **50** in TLS mode to track the position of the catheter distal tip **76A** as it advances within the patient vasculature, as has been described. Note, however, that for the tip confirmation functionality of the system **10**, the distal end **130B** of the stylet **130** need not be co-terminal with the catheter distal end **76A**. Rather, all that is required is that a conductive path between the vasculature and the ECG sensor assembly, in this case the core wire **138**, be established such that electrical impulses of the SA node or other node of the patient's heart can be detected. This conductive path in one embodiment can include various components including saline solution, blood, etc.

In one embodiment, once the catheter **72** has been introduced into the patient vasculature via the insertion site **73** (FIG. **10**) the TLS mode of the system **10** can be employed as already described to advance the catheter distal tip **76A** toward its intended destination proximate the SA node. Upon approaching the region of the heart, the system **10** can be switched to ECG mode to enable ECG signals emitted by the SA node to be detected. As the stylet-loaded catheter is advanced toward the patient's heart, the electrically conductive ECG sensor assembly, including the distal end of the core wire **138** and the conductive material **146**, begins to detect the electrical impulses produced by the SA node. As such, the ECG sensor assembly serves as an electrode for detecting the ECG signals. The elongate core wire **138** proximal to the core wire distal end serves as a conductive pathway to convey the electrical impulses produced by the SA node and received by the ECG sensor assembly to the tether **134**.

The tether **134** conveys the ECG signals to the TLS sensor **50** temporarily placed on the patient's chest. The tether **134** is operably connected to the TLS sensor **50** via the tether connector **132** or other suitable direct or indirect connective configuration. As described, the ECG signal can then be processed and depicted on the system display **30** (FIG. **9**, **10**). Monitoring of the ECG signal received by the TLS sensor **50** and displayed by the display **30** enables a clinician to observe and analyze changes in the signal as the catheter distal tip **76A** advances toward the SA node. When the received ECG signal matches a desired profile, the clinician can determine that the catheter distal tip **76A** has reached a desired position with respect to the SA node. As mentioned, in one embodiment this desired position lies within the lower one-third ($\frac{1}{3}$ rd) portion of the SVC.

The ECG sensor assembly and magnetic assembly can work in concert in assisting a clinician in placing a catheter within the vasculature. Generally, the magnetic assembly of the stylet **130** assists the clinician in generally navigating the vasculature from initial catheter insertion so as to place the distal end **76A** of the catheter **72** in the general region of the patient's heart. The ECG sensor assembly can then be employed to guide the catheter distal end **76A** to the desired location within the SVC by enabling the clinician to observe changes in the ECG signals produced by the heart as the stylet ECG sensor assembly approaches the SA node. Again, once a suitable ECG signal profile is observed, the clinician can determine that the distal ends of both the stylet **130** and the catheter **72** have arrived at the desired location with respect to the patient's heart. Once it has been positioned as desired, the catheter **72** may be secured in place and the stylet **130** removed from the catheter lumen. It is noted here that the stylet may include one of a variety of configurations in addition to what is explicitly described herein. In one embodiment, the stylet can attach directly to the console instead of an indirect attachment via the TLS sensor. In another embodiment, the structure of the stylet **130** that enables its TLS and ECG-related functionalities can be integrated into the catheter structure itself. For instance, the magnetic assembly and/or ECG sensor assembly can, in one embodiment, be incorporated into the wall of the catheter.

FIGS. **13A-15** describe various details relating to the passage of ECG signal data from the stylet tether **134** to the TLS sensor **50** positioned on the patient's chest, according to the present embodiment. In particular, this embodiment is concerned with passage of ECG signal data from a sterile field surrounding the catheter **72** and insertion site **73**, which includes the stylet **130** and tether **134**, and a non-sterile field, such as the patient's chest on which the TLS sensor is positioned. Such passage should not disrupt the sterile field so that the sterility thereof is compromised. A sterile drape that is positioned over the patient **70** during the catheter insertion procedure defines the majority of the sterile field: areas above the drape are sterile, while areas below (excluding the insertion site and immediately surrounding region) are non-sterile. As will be seen, the discussion below includes at least a first communication node associated with the stylet **130**, and a second communication node associated with the TLS sensor **50** that operably connect with one another to enable ECG signal data transfer therebetween.

One embodiment addressing the passage of ECG signal data from the sterile field to the non-sterile field without compromising the sterility of the former is depicted in FIGS. **13A-15**, which depict a "through-drape" implementation also referred to as a "shark fin" implementation. In particular, FIG. **14A** shows the TLS sensor **50** as described above for placement on the chest of the patient during a catheter

insertion procedure. The TLS sensor **50** includes on a top surface thereof a connector base **152** defining a channel **152A** in which are disposed three electrical base contacts **154**. A fin connector **156**, also shown in FIGS. **13A-13D**, is sized to be slidably received by the channel **152A** of the connector base **152**, as shown in FIGS. **14B** and **15**. Two ECG lead/electrode pairs **158** extend from the fin connector **156** for placement on the shoulder and torso or other suitable external locations on the patient body. The drape-piercing tether connector **132** is configured to slidably mate with a portion of the fin connector **156**, as will be described further below, to complete a conductive pathway from the stylet **120**, through the sterile field to the TLS sensor **50**.

FIGS. **13A-13D** show further aspects of the fin connector **156**. In particular, the fin connector **156** defines a lower barrel portion **160** that is sized to be received in the channel **152A** of the connector base **152** (FIGS. **14B**, **15**). A hole **162** surrounded by a centering cone **164** is included on a back end of an upper barrel portion **166**. The upper barrel portion **166** is sized to receive the tether connector **132** of the stylet **130** (FIGS. **14C**, **15**) such that a pin contact **170** extending into a channel **172** of the tether connector **132** (FIG. **15**) is guided by the centering hole until it seats within the hole **162** of the fin connector **156**, thus interconnecting the tether connector with the fin connector. An engagement feature, such as the engagement feature **169** shown in FIGS. **13C** and **13D**, can be included on either side of the fin connector **156** to engage with corresponding detents **173** (FIG. **13F**) on the tether connector **132** to assist with maintaining a mating between the two components. If disengagement between the two components is desired, a sufficient reverse pull force is applied to the tether connector **132** while holding or securing the fin connector **156** to prevent its removal from the channel **152A** of the connector base **152**.

FIG. **13D** shows that the fin connector **156** includes a plurality of electrical contacts **168**. In the present embodiment, three contacts **168** are included: the two forward-most contact each electrically connecting with a terminal end of one of the ECG leads **158**, and the rear contact extending into axial proximity of the hole **162** so as to electrically connect with the pin contact **170** of the tether connector **132** when the latter is mated with the fin connector **156** (FIG. **15**). A bottom portion of each contact **168** of the fin connector **156** is positioned to electrically connect with a corresponding one of the base contacts **154** of the TLS sensor connector base **152**. In one embodiment, the bottom portion of each contact **168** includes a retention feature, such as an indentation **168A**. So configured, each contact **168** can resiliently engage a respective one of the base contacts **154** when the fin connector **156** is received by the TLS sensor connector base **152** such that a tip of each base contact is received in the respective indentation **168A**. This configuration provides an additional securement (FIG. **15**) to assist in preventing premature separation of the fin connector **156** from the connector base **152**. Note that many different retention features between the base contacts **154** and the fin contacts **168** can be included in addition to what is shown and described herein.

FIGS. **13E** and **13F** depict various details of the tether connector **132** according to one embodiment, including the tether connector channel **172**, the pin contact **170** disposed in the channel, and detents **173** for removably engaging the engagement features **169** of the fin connector **156** (FIGS. **13A-13D**), as described above. FIG. **13E** further shows a plurality of gripping features **171** as an example of structure that can be included to assist the clinician in grasping the tether connector **132**.

FIG. 14B shows a first connection stage for interconnecting the above described components, wherein the fin connector 156 is removably mated with the TLS sensor connector base 152 by the sliding engagement of the lower barrel portion 160 of the fin connector with the connector base channel 152A. This engagement electrically connects the connector base contacts 154 with the corresponding fin contacts 168 (FIG. 15).

FIG. 14C shows a second connection stage, wherein the tether connector 132 is removably mated with the fin connector 156 by the sliding engagement of the tether connector channel 172 with the upper barrel portion 166 of the fin connector. This engagement electrically connects the tether connector pin contact 170 with the back contact 168 of the fin connector 156, as best seen in FIG. 15. In the present embodiment, the horizontal sliding movement of the tether connector 132 with respect to the fin connector 156 is in the same engagement direction as when the fin connector is slidably mated to the sensor connector base channel 152A (FIG. 14B). In one embodiment, one or both of the stylet 130/tether connector 132 and the fin connector 156 are disposable. Also, the tether connector in one embodiment can be mated to the fin connector after the fin connector has been mated to the TLS sensor, while in another embodiment the tether connector can be first mated to the fin connector through the surgical drape before the fin connector is mated to the TLS sensor.

In the connection scheme shown in FIG. 14C, the stylet 130 is operably connected to the TLS sensor 50 via the tether connector 132, thus enabling the ECG sensor assembly of the stylet to communicate ECG signals to the TLS sensor. In addition, the ECG lead/electrode pairs 158 are operably connected to the TLS sensor 50. In one embodiment, therefore, the tether connector 132 is referred to as a first communication node for the stylet 130, while the fin connector 156 is referred to as a second communication node for the TLS sensor 50. As will be seen, various other first and second communication nodes can be employed to enable the establishment of a conductive pathway between the ECG sensor assembly and the TLS sensor or other system component.

Note that various other connective schemes and structures can be employed to establish operable communication between the stylet and the TLS sensor. For instance, the tether connector can use a slicing contact instead of a pin contact to pierce the drape. Or, the fin connector can be integrally formed with the TLS sensor. These and other configurations are therefore embraced within the scope of embodiments of the present disclosure.

As mentioned, a drape 174 is often placed over the patient 70 and employed as a barrier to separate a sterile field of the patient, e.g., areas and components above the drape and proximate to the insertion site 73 (including the catheter 72, the stylet 130, and tether 134 (FIG. 10)) from non-sterile areas outside of the sterile field, e.g., areas and components below the drape, including the patient's chest, the sensor 50 (FIG. 10) placed on the chest, and regions immediately surrounding the patient 70, also referred to herein as a non-sterile field. As seen in FIG. 15, the sterile drape 174 used during catheter placement to establish the sterile field is interposed between the interconnection of the tether connector 132 with the fin connector 156. As just described, the tether connector 132 includes the pin contact 170 that is configured to pierce the drape 174 when the two components are mated. This piercing forms a small hole, or perforation 175, in the sterile drape 174 that is occupied by the pin contact 170, thus minimizing the size of the drape perfora-

tion by the pin contact. Moreover, the fit between the tether connector 132 and the fin connector 156 is such that the perforation in sterile drape made by piercing of the pin contact 170 is enclosed by the tether connector channel 172, thus preserving the sterility of the drape and preventing a breach in the drape that could compromise the sterile barrier established thereby. The tether connector channel 172 is shaped and configured so as to fold the sterile drape 174 down prior to piercing by the pin contact 170 such that the pin contact does not pierce the drape until it is disposed proximate the hole 162 of the fin connector 156 and such that the drape does not bunch up within the channel. It is noted here that the tether connector 132 and fin connector 156 are configured so as to facilitate alignment therebetween blindly through the opaque sterile drape 174, i.e., via palpation absent visualization by the clinician of both components.

As already mentioned, note further that the fin contacts 168 of the fin connector 156 as shown in FIG. 15 include the indentations 168A, which are configured to mate with the sensor base contacts 154 in such a way as to assist in retaining the fin connector in engagement with the sensor base channel 152A. This in turn reduces the need for additional apparatus to secure the fin connector 156 to the TLS sensor 50. In other embodiments, retention features that are separate from the electrical contacts can be employed to assist in retaining the fin connector in engagement with the sensor base channel. In one embodiment, the base contacts 154 can be configured as pogo pins such that they are vertically displaceable to assist in retaining the fin connector 156.

FIG. 16 shows a typical ECG waveform 176 of a patient, including a P-wave and a QRS complex. Generally, and with respect to the present system 10, the amplitude of the P-wave varies as a function of distance of the ECG sensor assembly from the SA node, which produces the P-wave of the waveform 176. A clinician can use this relationship in determining when the catheter tip is properly positioned proximate the heart. For instance, in one implementation the catheter tip is desirably placed within the lower one-third ($\frac{1}{3}$ rd) of the superior vena cava, as has been discussed. The ECG data detected by the ECG sensor assembly of the stylet 130 is used to reproduce waveforms such as the waveform 176, for depiction on the display 30 of the system 10 during ECG mode.

Reference is now made to FIG. 17 in describing display aspects of ECG signal data on the display 30 when the system 10 is in ECG mode, the third modality described further above, according to one embodiment. The screenshot 178 of the display 30 includes elements of the TLS modality, including a representative image 120 of the TLS sensor 50, with the icon 114 corresponding to the position of the distal end of the stylet 130 during transit through the patient vasculature. The screenshot 178 further includes a window 180 in which the current ECG waveform captured by the ECG sensor assembly of the stylet 130 and processed by the system 10 is displayed. The window 180 is continually refreshed as new waveforms are detected.

Window 182 includes a successive depiction of the most recent detected ECG waveforms, and includes a refresh bar 182A, which moves laterally to refresh the waveforms as they are detected. Window 184A is used to display a baseline ECG waveform, captured before the ECG sensor assembly is brought into proximity with the SA node, for comparison purposes to assist the clinician in determining when the desired catheter tip location has been achieved. Windows 184B and 184C can be filled by user-selected detected ECG

waveforms when the user pushes a predetermined button on the probe 40 or the console button interface 32. The waveforms in the windows 184B and 184C remain until overwritten by new waveforms as a result of user selection via button pushes or other input. As in previous modes, the depth scale 124, status/action indicia 126, and button icons 128 are included on the display 30. An integrity indicator 186 is also included on the display 30 to give an indication of whether the ECG lead/electrode pairs 158 are operably connected to the TLS sensor 50 and the patient 70.

As seen above, therefore, the display 30 depicts in one embodiment elements of both the TLS and ECG modalities simultaneously on a single screen, thus offering the clinician ample data to assist in placing the catheter distal tip in a desired position. Note further that in one embodiment a printout of the screenshot or selected ECG or TLS data can be saved, printed, or otherwise preserved by the system 10 to enable documentation of proper catheter placement.

Although the embodiments described herein relate to a particular configuration of a catheter, such as a PICC or CVC, such embodiments are merely exemplary. Accordingly, the principles of the present invention can be extended to catheters of many different configurations and designs.

FIGS. 18-19B depict examples of contact engagement configurations for the tether connector 132 and fin connector 156. Specifically, FIG. 18 depicts the fin contacts 168 of the fin connector 156 according to one embodiment, wherein the rear contact includes a spring clip configuration 168B for receiving the pin contact 170 (FIG. 15) of the tether connector 132 via the centering cone 164 or other aperture defined in the fin connector. FIGS. 19A and 19B depict an engagement scheme according to another embodiment, wherein the pin contact 170 of the tether connector 132 includes a barbed feature 170A that, when inserted into the centering cone 164 or other aperture of the fin connector 156, engages a shoulder 168C defined on the rear fin contact 168 of the fin connector so as to help prevent premature removal of the pin contact from the fin connector. These embodiments thus serve as non-limiting examples of a variety of contact configurations that can be included with the fin connector 156, the sensor connector base 152, and the tether connector 132. Note that unless referred to as otherwise, the contacts described herein are understood to include electrical contacts used in establishing a conductive pathway.

The embodiments to be described below in connection with FIGS. 20A-32 each depict an example connection scheme as a means for establishing a conductive or other communication pathway between a patient's sterile field and a non-sterile field, i.e., areas outside of the sterile field. Thus, the embodiments described herein serve as examples of structure, material, and/or compositions corresponding to the means for establishing a conductive or other communication pathway. In particular, various embodiments described herein disclose examples for breaching or otherwise circumventing a sterile barrier separating the sterile field from the non-sterile field so as to provide at least a portion of the conductive pathway for the passage of ECG signals from a sensing component such as the ECG sensor assembly of the stylet 130 to the sensor 50, also referred to herein as a TLS sensor or chest sensor, or other suitable data-receiving component of the system 10. Note that these embodiments are merely examples of a variety of means for establishing such a conductive or other communication pathway, and are not to be considered limiting of the scope of the present disclosure. It is therefore appreciated that the means for establishing a conductive or other communication

pathway can be employed for transferring ECG signals or other information, electrical signals, optical signals, etc.

As will be seen, many of the embodiments to be described include a tether connector, also referred to herein as a first communication node, which is operably connected to the stylet 130 and included in the sterile field, the tether connector is configured to operably attach to a connector included on the sensor 50 or other suitable component of the system 10, also referred to herein as a second communications node, which is disposed outside of the sterile field. Note, however, that the first communication node and second communication node are contemplated as generally referring to various connector interfaces that provide a conductive pathway from the sterile field to the non-sterile field to enable the passage of ECG signals as described above. It is appreciated that the conductive pathway is a communication pathway and includes an electrical pathway, an optical pathway, etc. Further, the communication node connection schemes described and contemplated herein can be employed with systems involving the use of modalities exclusive of ECG signals for navigation or placement of a catheter or other medical device.

Note further that the embodiments to follow that describe configurations for breaching a drape or other non-transparent sterile barrier are configured such that location of a communication node disposed out-of-sight under the drape/barrier is facilitated by palpation of the clinician, thus easing location and connection of the first and second communication nodes. Also, many of the connector configurations described herein can be configured as one-use, disposable components so as to minimize concerns with infection.

Reference is now made to FIGS. 20A-20C, which depict a connection scheme as a means for establishing a conductive pathway between sterile and non-sterile fields, according to one embodiment. In particular, FIGS. 20A-20C depict a tether connector 232 that includes an outer housing 234 and a blade holder 236 that attaches to the outer housing. A blade contact 238 is secured by the blade holder 236 such that the blade contact extends into a channel 240 of the tether connector. The blade contact 238 serves to create a slice perforation in a drape that is interposed between the tether connector and the fin connector 256 when the tether connector 232 is slid on to engage the fin connector in the manner described in previous embodiments. As before, the outer housing 234 of the tether connector envelops and protects the perforation so as to prevent contamination and compromise of the sterile field.

FIG. 20C shows that a fin connector 256 includes a fin contact 268 that is configured to physically interconnect with the blade contact 238 when the tether connector is slid on to the fin connector 256, thus establishing a conductive pathway through the sheath so as to enable ECG signals from an ECG sensing component, i.e., the ECG sensor assembly described above for instance, to pass to the sensor 50 via the blade contact 238/fin contact 268 engagement. Note that the particular configuration of the blade and fin contacts can be varied from what is described herein. For instance, the tether connector can include two or more blades or contacts for engagement with corresponding fin contacts to enable multiple conductive pathways to be established, if desired. The engagement surfaces of the tether connector and the fin connector can also vary from what is shown and described. In one embodiment, a light source can be included with the fin connector or other connectors as described herein so as to provide illumination

through the drape 174 and provide visual assistance in locating the fin connector for interconnection with the tether connector.

As seen in FIGS. 14A and 14B, in one embodiment the ECG leads 158 are permanently connected to the fin connector 156. FIG. 21A depicts another possible embodiment, wherein the ECG leads are removably attached to the fin connector 156 via a connector, such as a horseshoe connector 270, best seen in FIG. 21B. FIG. 21A further shows that the fin connector 156 is permanently attached to the sensor 50. These and other variations in the connective schemes of the various components of the system 10 are therefore contemplated as falling within the scope of the present disclosure. In another embodiment, the electrode of each lead is removably attachable from the lead, such as via a snap connection, for instance.

Reference is now made to FIGS. 22A-22C, which depict a connection scheme as a means for establishing a conductive pathway between sterile and non-sterile fields, according to one embodiment. In particular, FIGS. 22A-22C depict a tether connector 332 that includes a channel 372 for slidably engaging an upper barrel 166 of a fin connector 356 disposed on the sensor 50, in a manner similar to previous embodiments. The tether connector 332 includes a bi-positional top cap 374 to which is attached a pin contact 370 or other piercing contact.

The top cap 374 is positioned in an un-actuated first position, shown in phantom in FIG. 22B, when the tether connector 332 is first slid on to the fin connector 356. The drape, removed for clarity, is interposed between the upper barrel 166 of the fin connector 356 and the tether connector channel 372, similar to earlier embodiments. After the tether connector 332 is positioned on the fin connector 356, the top cap 374 can then be depressed by the clinician into an actuated second position shown in FIG. 22B, wherein the pin contact 370 is pressed downward through the drape and into operable engagement with a corresponding contact disposed in the fin connector 356. The tether connector 332 is thus positioned as shown in FIG. 22C. In addition to establishing a conductive path through the drape 174, this engagement of the pin contact 370 locks the tether connector 332 on to the fin connector 356 so as to prevent premature separation of the components.

Reference is now made to FIGS. 23A and 23B, which depict a connection scheme as a means for establishing a conductive pathway between sterile and non-sterile fields, according to one embodiment. In particular, FIG. 23A depicts a tether connector 432 including a pin contact 440 or other suitable contact attached to an actuation assembly 442. The actuation assembly 442 includes lever arms for selectively lowering the pin contact 440 through an opening defined by a male end 448 of a housing 446 in which the actuation assembly is disposed. The male end 448 of the housing is configured to be received by a sensor connector receptacle 450 disposed on the sensor 50 or other suitable component of the system, such as a remote module operably connected to the sensor, for instance.

To interconnect the tether connector 432 to the sensor connector receptacle 450, the male end 448 of the tether connector 432 is brought, above the drape 174, into proximity with the receptacle 450. The actuation assembly 442 is then actuated by raising the lever arms 444, as shown in FIG. 23B. The pin contact 440 is forced downward through the drape 174, thus defining a perforation therein. The male end 448 can then be fully received into the sensor receptacle 450, wherein the pin contact 440 operably connects with a suitable contact of the sensor connector receptacle. The

connector scheme shown in FIGS. 23A and 23B is useful for imposing a minimal downward force on the body of the patient during connector interconnection. Further, the actuation assembly 442 provides a predetermined force in connecting the first communication node (the tether connector 432) with the second communication node (the sensor connector receptacle 450), and thus does not rely on a clinician's estimation of force to establish the node connection. In another embodiment, the housing 446 and the sensor receptacle 450 can be aligned and mated before the actuation assembly 442 is actuated to pierce the contact 440 through the drape.

Reference is now made to FIG. 24, which depicts a connection scheme as a means for establishing a conductive pathway between sterile and non-sterile fields, according to one embodiment. As in the embodiment shown in FIGS. 23A and 23B, the present interconnection scheme minimizes downward pressure on the body of the patient during interconnection of the nodes. As shown, a tether connector 532 includes a pin contact 540 or other suitable contact included with a threaded cap 542, which defines threads on an inside surface thereof. The threaded cap 542 is configured to threadingly receive a threaded base 544 disposed on the sensor 50 or other suitable component of the system, such as a remote module operably connected to the sensor, for instance. As before, the drape 174 is interposed therebetween.

To interconnect the tether connector 532 to the sensor 50, the threaded cap 542 of the tether connector is brought, above the drape 174, into proximity with the threaded base 544 and threaded on to the base. This causes the pin contact 540 to penetrate the drape 174, thus defining a perforation therein. Further threading of the cap 542 on to the base 544 causes the pin contact 540 to engage a contact receptacle 546 included in the base 544, thus operably interconnecting the two nodes. In one embodiment, the tether 134 is rotatably attached to the threaded cap 542 so as to prevent twisting of the tether during threading. The connector scheme shown in FIG. 24 is useful for imposing a minimal downward force on the body of the patient during connector interconnection as the force to join the two connectors is directed laterally with respect to the patient via the threading operation. Note further that a variety of thread configurations and locations, as well as different cap and base configurations, are contemplated by the present disclosure.

Reference is now made to FIGS. 25A and 25B, which depict a connection scheme as a means for establishing a conductive pathway between sterile and non-sterile fields, according to one embodiment. As in the previous embodiment, the present interconnection scheme minimizes downward pressure on the body of the patient during interconnection of the nodes. As depicted in FIGS. 25A and 25B, a tether connector 632 includes one or more piercing contacts, such as pin contacts 640A and 640B that are respectively included on slide arms 642A and 642B. One or more contact receptacles, such as contact receptacles 644A and 644B, are included on a portion of the sensor 50, such as a sensor fin 646, or other suitable system component. As before, the drape 174 is interposed between the tether connector 632 and the sensor fin 646 to serve as a sterile barrier.

To interconnect the tether connector 632 to the sensor fin 646, the tether connector is brought, above the drape 174, into proximity with the sensor fin such that the slide arms 642A and 642B straddle the sensor fin and such that the pin contacts 640A and 640B are aligned with corresponding contact receptacles 644A and 644B, as shown in FIG. 25A. The slide arms 642A and 642B are then slid toward one

another such that the pin contacts **640A** and **640B** penetrate the drape **174**, each defining a perforation therein. The slide arms **642A** and **642B** are slid inward until the pin contacts **640A** and **640B** seat within and operably connect with the corresponding contact receptacles **644A** and **644B**, as seen in FIG. **25B**, thus interconnecting the two nodes. The connector scheme shown in FIGS. **25A** and **25B** is useful for imposing a minimal downward force on the body of the patient during connector interconnection as the force to join the two connectors is directed laterally with respect to the patient. Note that the particular configuration of the tether connector, the sensor fin, and the contacts can vary from what is explicitly described herein. For instance, in one embodiment the slide arms can be configured as bi-positional rocker arms that are connected in a see-saw configuration with respect to one another. Also, one, two, or more contacts can be included on the slide arms.

Reference is now made to FIGS. **26A** and **26B**, which depict a connection scheme as a means for establishing a conductive pathway between sterile and non-sterile fields, according to one embodiment. As shown, an integrated connector **730** is incorporated into the drape **174** so as to enable operable interconnection therethrough. In the illustrated embodiment, the integrated connector **730** includes a conductive base portion **734** from which extend mechanical connectors, such as snap balls **736A** and **736B**.

As shown in FIG. **26B**, the integrated connector **730** is positioned in the drape **174** as to be connectable with both a suitable receptacle **738** of a tether connector **732** and a suitable receptacle **740** of the sensor **50** or other suitable component of the system **10**. In particular, the tether connector **732** can be snap-attached to the integrated connector **730**, after which the integrated connector can be attached to the sensor **50**, thus providing a suitable pathway for signals from the ECG sensor assembly in the sterile field to be transmitted through the sterile barrier of the drape **174** to the sensor in the non-sterile field. It is appreciated that, in other embodiments, the integrated connector can include other configurations, such as different mechanical connectors, e.g., friction connectors, male/female connectors, etc., and as such the receptacles on the tether connector and sensor can likewise be modified to accommodate the different mechanical connectors. Also, the connective scheme described above can be reversed such that the receptacles are included on the integrated connector and the snap balls on the respective tether connector and sensor. Further, though presently depicted as a unitary component, the integrated connector in other embodiments can include two or more pieces that are attached to each other through a previously defined hole in the drape during manufacture thereof. These and other variations are therefore contemplated.

Reference is now made to FIG. **27**, which depicts a connection scheme as a means for establishing a conductive pathway between sterile and non-sterile fields, according to one embodiment. In detail, FIG. **27** depicts an intermediate module, i.e., ECG module **750**, disposed outside of the sterile field of the patient, which is operably connected to the sensor **50** of the system **10** via a sensor cable **752**. The ECG module **750** is also operably connected to the ECG leads **158**. In one embodiment, the ECG module **750** includes the circuitry and other components necessary for receipt and analysis of the ECG signal detected by the ECG sensor assembly of the stylet **130**. As such, a conductive pathway is established between the stylet **130** and the ECG module **750** by traversing the sterile field of the patient. In the present embodiment, this is accomplished by a tether connector **762** of the tether **134**.

As depicted in FIG. **27**, the tether connector **762** operably attaches to a receptacle **764** of the ECG module **750**. As shown, the tether connector **762** can include a sufficiently long handle that enables the clinician to attach the sterile tether connector to the receptacle **764** of the non-sterile ECG module **750** without touching the ECG module itself, thus preventing any compromise of the sterile field. In one embodiment, the handle of the tether connector **762** can include an extendable J-hook contact, for instance, that can operably connect to a suitable contact of the ECG module.

FIG. **27** further depicts a footswitch **1116**, usable with any of the embodiments described herein, which may be placed on the ground near the feet of the clinician and employed to control selected aspects of system functionality during catheter placement procedures. For instance, in one embodiment, the footswitch **1116** can be used to freeze ECG waveform images on the system display **30**, or to create a printout of the display during the procedure, or even after the procedure is complete so as to provide a record of final catheter placement. Of course, the design and functionality of the footswitch can be modified in many ways from what is explicitly shown and described herein.

FIG. **28** shows another example of a tether connector that can be employed with the ECG module **750** of FIG. **27** or other suitable component of the system **10** as part of a connection scheme as a means for establishing a conductive pathway between sterile and non-sterile fields, according to one embodiment. In particular, FIG. **28** depicts a tether connector **832**, which includes a handle and a barbed contact **836** or other suitable contact at a proximal end thereof. A sterile shield **838** is interposed between the handle **834** and the contact **836**. The sterile shield **838** assists in protecting the hand of the clinician while inserting the contact **836** into the receptacle **764** of the ECG module **750** in a manner similar to what is shown in FIG. **27**. Thus, the sterile shield **838** serves as an additional barrier to prevent inadvertent contact by the clinician with a component outside of the sterile field, such as the ECG module **750**. Note that the size, shape, and particular configuration of the sterile shield and/or tether connector can vary from what is explicitly described in the present embodiment.

FIGS. **29A** and **29B** show yet another example of a connection scheme that can be employed with the ECG module **750** of FIG. **27** or other suitable component of the system **10** as a means for establishing a conductive pathway between sterile and non-sterile fields, according to one embodiment. In particular, FIG. **29A** shows that the ECG module **750** can be enveloped by a sterile bag **850**. A connector, such as the integrated connector **730** described above in connection with FIGS. **26A** and **26B**, can be incorporated into the bag. As shown in FIG. **29B**, an inner snap ball or other mechanical connector of the integrated connector **730** can be received by the suitably corresponding receptacle **764** of the ECG module **750**. The tether connector of the system **10** can then be operably connected with the outer snap ball or other connector of the integrated connector **730**, thus establishing a conductive pathway between the sterile field and the non-sterile field without compromising sterility. Note that the sterile bag **850** can include any one or more of a variety of suitable materials, including plastic. Note also that the integrated connector can include other connector configurations in addition to what is explicitly described herein. In one embodiment, the sterile bag includes no integrated connector, but rather is pierced by a pin contact of the tether connector, such as the barbed contact **836** included on the tether connector **832** of FIG. **28**.

Reference is now made to FIG. 30, which depicts a connection scheme as a means for establishing a conductive pathway between sterile and non-sterile fields, according to one embodiment. Specifically, the stylet 130 includes a tether connector 862 as a first communication node, as in previous embodiments. A remote sensor connector 864 is also included as a second communications node, and is operably connected to the sensor 50 of the system 10 via a remote sensor connector cable 866. The tether connector 862 and remote sensor connector 864 operably connect to one another along a connection interface 868. The drape 174 that serves as a sterile barrier is interposed between the tether connector 862 and remote sensor connector 864 at the connection interface 868, and a suitable drape piercing configuration is included with the tether connector and the remote sensor connector to establish a conductive pathway through the drape. The present embodiment thus discloses one embodiment wherein the second communication node is located remotely with respect to the sensor 50.

Reference is now made to FIG. 31, which depicts a connection scheme as a means for establishing a conductive pathway between sterile and non-sterile fields, according to one embodiment. Specifically, the present embodiment includes the tether connector 862 and the remote sensor connector 864 that operably connect to one another along the connection interface 868, as described in connection with FIG. 30, above. The remote sensor connector 864 in the present embodiment is placed proximate the catheter insertion site 73 in a region over which a fenestration 880 defined in the drape 174 (portions of the drape omitted for clarity) is positioned to enable clinician access to the insertion site during catheter placement. The remote sensor connector 864 is adhered to the patient's skin proximate the catheter insertion site 73 with the use of an adhesive, tape, etc., before the region surrounding the insertion site is sterilized in preparation for catheter insertion. Thus, when the insertion site is sterilized, the remote sensor connector 864 is also sterilized. Later, when connection of the tether connector 862 to the remote sensor connector 864 is made, the clinician can handle the latter component without compromising the sterile field of the patient. It is appreciated that the particular configurations of the tether connector and the remote sensor connector can vary while still residing within the scope of the present embodiment.

Reference is now made to FIG. 32, which depicts a connection scheme as a means for establishing a conductive pathway between sterile and non-sterile fields, according to one embodiment. Specifically, FIG. 32 shows the probe 40 employed by the system 10 for US functionality, as described above in connection with FIGS. 3A and 3B. A sterile sheath 900 is placed over the probe 40 so as to bring the probe into the sterile field of the patient. A connection interface, such as a receptacle 910, is included on the probe 900 and is configured so as to be operable connectable with a tether connector 920. In one embodiment, for example, the tether connector 920 includes a pin contact that penetrates the sterile sheath 900 to mate with the receptacle 910 in such a way as to prevent contamination of the sterile field. In this way, the tether connector 920, as a first communication node, operably connects with the probe 40, as a second communications node. In turn, the probe 40 is operably connected to the system console 20, as seen in FIG. 31 for example, so as to enable ECG signals received by the ECG sensor assembly of the stylet 130 via the tether connector 920 to be forwarded to the console, the sensor 50, or other system component for processing, as described above. In another embodiment, the receptacle 910 or other suitable

connection interface can be included on the cable connecting the probe 40 to the system console 20. The particular contact configuration of the receptacle 910 and tether connector 920 can be varied according to the understanding of one skilled in the art. For instance, an integrated connector such as that shown in FIGS. 26A and 26B can be incorporated into the sterile sheath in one embodiment. Note further that, though including plastic in the present embodiment, the sterile sheath as described herein can include other suitable materials for providing sterility.

Reference is now made to FIG. 33 in describing means for establishing a conductive pathway between sterile and non-sterile fields, according to one embodiment. As shown, the tether 134 includes a wireless module 950, included within the sterile field, which serves as a first communication node for wirelessly transmitting (via RF or other suitable frequency or frequency range) ECG data received from the ECG sensor assembly of the stylet 130 to a data-receiving component as a second communication node, such as the sensor 50 or other suitable component of the system 10. A wireless module ground electrode 952 is operably connected with the wireless module 950 for placement in the sterile field proximate the catheter insertion site 73. A system ground electrode 158A extends from the sensor 50 for placement outside of the sterile field but proximate both the catheter insertion site 73 and the location of the wireless module ground electrode 952. One possible placement location for the system ground electrode 158A is beneath the patient arm, as depicted in FIG. 33. The system reference electrode 158B is placed on the lower torso of the patient 70 or other suitable location, as in previous embodiments. Note that the wireless module and system console as discussed herein can be configured in one or more of a variety of ways and include components for wireless signal transmission and reception not specifically detailed herein, such as patch or other antennas, signal transducers, etc.

With the system configured as shown in FIG. 33, the system ground electrode 158A can be electrically driven such that it produces a voltage that is sensed by the passive wireless module ground electrode 952, given its proximate location with respect to the system ground electrode. This enables both ground electrodes to be at substantially equal electric potentials, thus enabling the wireless module 950 to utilize the wireless module ground electrode 952 and the ECG signals from the ECG sensor assembly of the stylet 130, e.g., the core wire 138 (FIGS. 12C-12E) in one embodiment, to detect and wirelessly transmit the ECG data to the sensor 50 for comparison with the data sensed by the system reference electrode 158B in order to obtain the desired P-wave waveform (e.g., FIG. 16). The data comparison in one embodiment is a differential comparison between the ECG data as obtained by the ECG sensor assembly of the stylet 130, the wireless module ground electrode 952, and the system reference electrode 158B. In one embodiment, the system ground electrode 158A, like the wireless module ground electrode 952, can be passive and not electrically driven. Note also that the analog ECG data can be digitized or otherwise processed by the wireless module 950 before transmission to the sensor 50 or other system component, such as the console 20.

FIG. 34 describes yet another wireless configuration as a means for establishing a conductive pathway between sterile and non-sterile fields, according to one embodiment. As shown, a positive electrode 954A at a location A and a negative electrode 954B at a location B are included with the sensor 50 and positioned on the torso of the patient 70, while a positive wireless module electrode 956 is included with the

wireless node **950**, as indicated at location C, positioned on or in the patient proximate the catheter insertion site **73**. The ECG sensor assembly of the stylet **130**, e.g., the core wire **138** in one embodiment, serves as a negative electrode for the wireless portion of the depicted configuration, indicated at D in FIG. **34** at its final position. Note that in one embodiment the locations A and B of the electrodes **954A** and **954B**, respectively, can be altered on the patient body to tune the system **10** for best ECG signal reception.

In the present embodiment, the electrodes **954A** and **954B** serve as a first independent source for sampling bipolar ECG signals. The ECG data from these electrodes are digitized and forwarded to the console **20** or other suitable system component via the cable interconnecting the sensor **50** and the console (path **1**) outside of the sterile field. The wireless module electrode **956** and the ECG sensor assembly serve as a second independent source for sampling bipolar ECG signals. The ECG data from these electrodes are digitized and forwarded wirelessly to the console **20** via the wireless module **950** (path **2**) within the sterile field. Thus, in the present embodiment the wireless module **950** serves as a first communication node, and a wireless receiver of the console **20** as a second communication node for the transfer of ECG signals between the two nodes. Note that the polarities of the afore-mentioned electrodes can be reversed in other embodiments.

The ECG signals received along both paths **1** and **2** are baseline corrected by appropriate circuitry of the console **20** to adjust for DC offset and drift. After such correction, a non-changing reference, or baseline, P-wave waveform **176A** from path **1** can be produced, as seen in FIG. **35A**, for example. Similarly, a P-wave waveform **176B** as seen in FIG. **35B** is produced from path **2**, which waveform changes as the stylet **130** within the catheter **72** is advanced toward the heart of the patient. During such advancement, the waveform **176B** from path **2** is subtracted from the P-wave waveform **176A** from path **1**, employing a digital differential amplifier, for instance. This subtraction removes all common components of the waveforms represented by each of the signals, and enables the console **20** to depict via its display **30** only the differences in the two signals, as seen for example by the waveform **176C** shown in FIG. **35C**. The change in P-wave of the waveform from path **2** can then be easily observed during catheter advancement. Thus the present embodiment enables an easily observable digital display of ECG data to be represented while preventing a physical breaching of a sterile barrier, such as a surgical drape, for the passage of such data.

Note that in other embodiments the wireless module electrode **956** can include other configurations, including a conductive element imbedded into an introducer sheath, in contact with the bloodstream of the patient, which is commonly disposed through the insertion site **73** during catheter placement. The introducer can include a connector on a proximal portion thereof to enable a connection with the wireless node **950** to be made, in one embodiment.

Note further that one or more of a variety of wireless protocols can be employed in transmitting wireless signals in accordance with the embodiments described herein, including one or more of the IEEE 802.11 family of specifications, etc. Also note that in one embodiment the wireless module can be included in a sterile sheath, as described in previous embodiments, to bring the module within the sterile field, together with connectors for operably connecting the wireless module electrode through the sheath or included in the sheath itself. Of course, other methods for maintaining the wireless module within the sterile field can

also be employed. In one embodiment, the wireless module can include buttons that further enable control of the system **10** from within the sterile field.

FIG. **36** shows that in one embodiment the sensor **50** can be retro-fitted with a wireless module **960** to enable signals received by the sensor to be wirelessly transmitted to the console **20** or other suitable component of the system **10**. For instance, ECG data received by the ground and reference electrodes **158A**, **158B** (FIG. **34**) can be received by the sensor **50** then wirelessly transmitted to the system console via the wireless module **960**. The wireless module **960** can include an antenna or other transmitting component and can operably connect to the sensor **50** via a sensor cable **962** or other suitable interface. Note that the wireless module **960** can be employed in connection with other embodiments described herein, including those depicted in FIGS. **10** and **33**, for instance.

FIG. **37** shows a retention feature for preventing inadvertent separation of the fin connector **156** from the sensor connector base **152** or other receptacle with which the fin connector operably connects, according to one embodiment. As shown, the fin connector **156** includes a retention arm **970** that is resiliently attached to the fin connector body. The retention arm **970** includes a tab **972** that slides over and engages a lip **974** included with the connector base **152** of the sensor **50** when the fin connector **156** is slidably received in the sensor channel **152A** (FIG. **14A**). The engagement of the tab **972** with the lip **974** prevents inadvertent removal of the fin connector **156** during use. When removal of the fin connector **156** from the sensor connector base **152** is desired, the retention arm **970** is lifted so as to disengage the tab **972** from the lip **974**, after which the fin connector can be slid out of engagement with the sensor channel **152A**. This configuration can be employed either with or independent of other retention features, such as the indentations **168A** (FIG. **13D**). Note that in other embodiments a variety of modifications and configurations can be employed in assisting to maintain engagement between the fin connector and the connector. For instance, the retention arm in one embodiment can be operably attached to one or more of the fin contacts **168** (FIG. **13D**) such that displacement, e.g., lifting laterally moving, pinching, etc., of the retention arm or other suitable fin connector component disengages the fin contact (s) from the base contacts (FIG. **15**), thus reducing the overall retention force provided by the engagement of the fin contacts with the base contacts. Note further that these principles can be applied to the other connector schemes disclosed or contemplated in addition to the fin connector described here.

In addition to the above embodiments depicting various connection schemes as means for establishing a conductive pathway between sterile and non-sterile fields, other configurations can be employed, as appreciated by one skilled in the art, for performing the same functionality. Such other configurations can include, for example, wireless transmission of ECG signals from the stylet to the sensor or the system component, the inclusion of electrically conductive thread in the drape, the inclusion of an electrically conductive window (e.g., composed of an electrically conductive plastic or foil) in the sterile drape, etc. In yet another embodiment, a proximal end of the stylet/guidewire itself can be used to pierce the drape for receipt into a connector on the sensor. In this case, no tether is included on the proximal end of the stylet, and the stylet itself serves as the conductive pathway for transmitting ECG signals from the stylet sensor assembly to the sensor on the patient's chest. Such a configuration can allow for over-the-wire placement

of the catheter using a stylet/guidewire as described here. As such, the above embodiments should not be construed as being limiting of the present invention in any way.

FIG. 38 shows a catheter 982 as one example of a catheter that can be employed with the catheter placement system 10 described in the embodiments disclosed herein. The catheter 982 includes a conductive annular band 984, positioned proximate the distal end 982B (though other locations along the catheter are also possible), which serves as an ECG sensor, or electrode, for detecting ECG signals from an emitting heart node of the patient 70 when the catheter is at least partially inserted within the patient vasculature. A conductive wire 986 extends along the length of the catheter 982 and in one embodiment is embedded in the catheter wall, such as by co-extrusion for instance, for connection with external ECG signal receiving components external to the patient. Note that this is but one example embodiment of a catheter and ECG sensor electrode configuration, in addition to those described above and appreciated by one skilled in the art. Yet other possible configurations are disclosed in U.S. Patent Publication No. 2010/0222664, entitled "Catheter Assembly Including ECG Sensor and Magnetic Assemblies," which is incorporated herein by reference in its entirety.

FIG. 39 shows the catheter 982 for use with the system 10 including an ECG sensor assembly 990 according to one embodiment, wherein the catheter includes a plurality of ECG sensors, or electrodes 994A, 994B, and 994C. The electrode 994C is positioned proximate the catheter distal end 982B, while the remaining electrodes 994A and 994B are positioned on the catheter proximal thereto. Each electrode is operably connected to a respective conductive pathway, such as a conductive wire proximally extending from the electrode along the length of the catheter so as to enable detected ECG signals to be forwarded to the external TLS sensor 50 or other suitable system component. The electrodes 994A-994C can be configured in one or more of a variety of configurations suitable to act as sensors for detecting an ECG signal of the patient's heart. Also, though shown as close-ended, the catheter 982 can be open-ended in one embodiment.

As shown in FIGS. 40A-40C, the ECG sensor assembly 990 can be employed in determining the proximity of the catheter distal end 982B to the SA node, wherein the sensor assembly of the catheter 982 includes in the illustrated embodiment two electrodes 994A and 994B. In FIG. 40A, as the catheter distal end 982B approaches the SA node, the P-waves 996A and 996B of the ECG waveforms detected by the catheter electrodes 994A and 994B, respectively, both show an increase in P-wave amplitude. Because of its relatively more proximate position to the SA node, however, the electrode 994B shows a P-wave with a relatively larger amplitude. A superposition of the P-waves 996A and 996B as detected by the system 10, for instance, is shown at 998. Observation of this relationship on the system display, for instance, can give needed information to a clinician during placement of the catheter so as to aid in advancement of the catheter distal end 982B toward the SA node.

FIG. 40B shows that when the two electrodes 994A and 994B are equidistant with respect to the SA node, the amplitudes of the P-waves 996A and 996B are approximately equal, which fact is further shown by the superposition 998 of the P-waves. In FIG. 40C, the distal electrode 994B is relatively farther from the SA node than the electrode 994A, and as such its corresponding P-wave 996B is smaller relative to the P-wave 996A. Note that the type and number of electrodes can be varied from what is shown here.

In another embodiment, a filtering process can be employed in connection with use of the ECG electrodes 994A, 994B of the catheter 982 described here, wherein portions of the ECG waveforms detected by the electrodes other than the P-wave portion are cancelled out, leaving only the differences in the detected P-waves between the two electrodes to be depicted. This process is similar to that employed in connection with FIGS. 34-35C, as described above.

FIGS. 41A-41C depict various possible states for the ECG electrode integrity indicator 186, also shown as displayed on the screenshot 178 of the system display 30 in FIG. 17. The integrity indicator 186 is an icon that is displayed on the system display 30 and is part of a connection integrity component to verify the status of the connections of the various ECG signal paths with the external sensor 50, i.e., whether the connections are closed and ready for use during catheter placement procedures. Such lead verification is helpful to avoid having to remove the sterile drape and reinitiate the placement procedure if the various ECG electrodes were not properly connected before placement of the sterile drape and establishment of the sterile field about the patient.

In FIG. 41A, the integrity indicator 186 shows that no connections to the external sensor 50 are currently closed. In contrast, FIG. 41B shows that the connection between the sensor 50 and the ECG electrodes 158 (FIG. 14B) is closed, indicated by the shaded connection symbol 1004. FIG. 41C shows in addition that the connection between the sensor 50 and the ECG sensor of the stylet 130 (e.g., the core wire 138 in FIGS. 12C and 12D via the tether 134 and tether connector 132) is closed, as indicated by the shaded connection symbol 1006. Thus, the integrity indicator view in FIG. 41A represents the connection status shown in FIG. 14A, the indicator view in FIG. 41B represents the connection status shown in FIG. 14B, and the indicator view in FIG. 41C represents the connection status shown in FIG. 14C.

The system 10 can confirm the status of the above connections in one or more of a variety of ways using connection integrity components, including capacitive or inductive sensing circuits included with the sensor 50 and/or console 20 for instance, impedance-based methods, time or frequency reflectometry techniques, etc. One possible voltage balance-based connection integrity component system is shown at 1120 in FIG. 41D. In particular, the circuitry of the system 1120 includes a first resistor pair 1122 and an amplifier 1124, such as an instrumentation amplifier, operably connected via communication lines 1126, as are the other components of the present system, as shown in FIG. 41D. A second resistor pair 1128, amplifiers 1130 and 1132, an analog-to-digital converter ("ADC") 1134, and processor 1136 are also included in the system and interconnected as shown in FIG. 41D. The processor 1136 is included in the external TLS sensor 50 in one embodiment, but can be incorporated into other system processors or included in other components, such as the console 20 in one embodiment. The various ECG electrodes of the system 10 are shown attached to the body of the patient 70, i.e., the internal ECG sensor (E1 in FIG. 41D) such as the stylet core wire 138 in the configuration shown in FIGS. 12A-12E, and both the external reference external ECG electrode 158 (E2) and second external electrode (E3) shown in FIGS. 14A-14C.

In preparation for use of the system 10, the integrity check system 1120 can be used to ensure that the external ECG electrodes are properly connected both to the body of the patient 70 and to the external TLS sensor 50 of the system 10 in one embodiment. Reference voltage V_{ref} , shown at

1140, is driven, such as by a voltage regulator, to a predetermined value, such as 4 volts, for instance, while the voltage at the external electrode E3 is maintained at a relatively lower value, such as 2 volts for instance. The values of the voltages V1 and V2 from the electrodes 1 and 2, respectively, in FIG. 41D are averaged to generate a common mode voltage, V_{cm} , indicated at 1142. In one embodiment, the processor 1136 monitors V_{cm} , as sampled via the ADC 1134. When the external ECG electrodes E2 and E3 are properly connected to the patient body and TLS sensor 50, V_{cm} will be pulled lower in value, in one embodiment approaching about 2 volts, though other values are possible. If one or both of the external electrodes E2 and E3 are not properly connected, however, V_{cm} will be pulled higher toward the value of V_{ref} , or about 4 volts in the present embodiment. As such, monitoring of V_{cm} by the processor 1136 can determine the connectivity of the external ECG electrodes. These data relating to the connectivity status of the external ECG electrodes can be forwarded to the display 30 by the processor 1136 for depiction by the indicator 186 on the display 30 shown in FIGS. 41A-41C.

FIG. 42 shows yet another possible connection integrity component configuration according to one embodiment, wherein a passive lead continuity check system is employed, eliminating any need for injecting current into the leads that extend from the various ECG electrodes of the system 10. As shown, a radiating element 1010 is included relatively near the ECG electrode leads, such as on the sensor 50. The radiating element 1010 is configured to emit a signal of a known frequency. The ECG lead wires, such as the wires of the external ECG electrodes 158 and the tether 134, act as antennae to passively detect the signal radiated by the radiating element 1010. When the ECG leads are properly attached to the sensor 50, the antenna effect of the ECG lead wires is minimized, such that the radiating signal present on the ECG lead wires is suppressed. Sensor and/or console circuitry is configured so as to detect the radiating signal present on the ECG leads and compare it to a threshold signal level. If the detected radiating signal is above the threshold, the system reports that the ECG leads are not properly connected. When the detected signal is below the threshold, the system reports that the leads are properly connected. The present configuration is passive and does not necessitate the passing of current down the ECG leads in order to check connection integrity for the connective path check.

In one embodiment, the connection check scheme of FIG. 42 can be configured such that different graduated levels of signal present on the leads will indicate whether sub-connections upstream from the ECG electrode are closed. In another embodiment, natural signal line noise in the natural 60 Hz, 120 Hz or 180 Hz frequencies, naturally present on the lead wires, can be used for detection, thus eliminating the need for the radiating element 1010.

It is appreciated that other icons and designs can be used to implement the functionality described in connection with FIGS. 41A-41C, and that connection status checking can be varied according to modifications made to the catheter placement system. Of course, other visual or aural indications can be used to convey electrode connection status.

FIGS. 43A-43B depicts details of a stylet configuration including a mode for checking whether the stylet 130 has been inadvertently cut, such as when the stylet is undesirably left in the catheter lumen when the catheter 72 is trimmed before being inserted into the patient 70. As shown, in one embodiment, the stylet 130 can include a core wire 1014 and a plurality of magnetic elements 1016 covered by a tubing

sleeve 1018, together with a conductive epoxy 1020 included at the stylet distal end. A conductive wire loop 1024 is included in the stylet and loops at the distal end 130B of the stylet 130 so as to form a circuit when suitably connected with the system 10. The conductive wire loop 1024 thus defines a continuity circuit that checks the continuity of the distal portion of the stylet. If the stylet has been inadvertently cut, such as by improper catheter trimming as shown in FIG. 43B, the loop is opened and the continuity check fails, indicating the catheter tip has been compromised. The continuity check can be performed before the catheter 72 is inserted into the patient vasculature so as to prevent catheter guidance problems after insertion. In another embodiment, the conductive wire loop 1024 could be configured so as to be exposed to the patient bloodstream and additionally serve as an ECG electrode.

FIG. 44 shows one of many possible variations to the previous embodiment, wherein the conductive wire loop 1024 is implemented as a planar wire, which has a bias toward bending within the plane of least thickness. Such a planar wire can be used in stylets that have a pre-curved configuration, such as that shown in FIG. 44. In addition, in one embodiment such a wire enables the direction of stylet bending to be controlled along one axis, if desired. Indeed, in one embodiment, tension can be imparted to the planar wire in order to cause the distal portion of the stylet 130 to selectively deflect from a straight to a curved configuration as shown in FIG. 44, for example. It should be noted that the embodiments just described can be implemented in stylets having one of a variety of configurations in terms of structure, size, etc. In other embodiments, Note that in other embodiments, other techniques can be employed to ensure the stylet has not been cut or otherwise compromised, including stylet checks using time or frequency domain reflectometry, for instance.

FIGS. 45 and 46 depict a mechanical solution for preventing unintended proximal advancement of the stylet 130 within the catheter 72. In particular, FIG. 45 shows a bulbous mechanical interference feature 1028 included on the stylet distal end 130B so as to impede retraction of the stylet into the catheter lumen. FIG. 46 shows another example, wherein the stylet distal end 130B includes a deflected extended portion interference feature 1028. Of course, mechanical interference features of many different sizes and shapes can be employed, including arrow-shaped, spherical, etc.

FIGS. 47A and 47B depict an electrical solution to assist in preventing misalignment of the distal ends of the catheter 72 and the stylet 130. As shown, a conduction band 1032 is embedded within the catheter so as to be in electrical communication with two conductive portions 1036 of the stylet 130 between which is interposed a nonconductive stylet portion 1034. When the stylet distal end 130B is properly aligned with the distal end 72B of the catheter 72, the more distal stylet conductive portion 1036 is conductively connected to the more proximal stylet conductive portion 1036 via the catheter-embedded conduction band 1032. Should the stylet and catheter distal ends 130B, 72B be misaligned, however, no such conductive path is established, and the absence of this path can be detected by the sensor 50, console 20, or other suitable component of the system 10 so as to enable its rectification.

FIG. 48 depicts one possible implementation of a dual ECG electrode assembly 1040 for placement on the skin of the patient 70 during catheter placement procedures. As shown, the assembly 1040 includes dual electrodes 1042A, 1042 B a single pad, for simplifying the ECG lead place-

ment. Corresponding leads **1044** are also included. In other embodiments, the ECG electrode assembly can include more than two electrodes, if desired.

FIG. **49** shows one example of an external ECG external electrode assembly for placement on the skin of the patient **70**, including the previously-described fin connector **156**, and external ECG electrodes **158**. Graphics **1048** are positioned on a surface of each electrode **158** including illustrations to assist the clinician in placing the ECG electrodes in the proper location on the patient's body. This assists clinicians who may not be familiar with the proper placement locations for the electrodes on the patient's body **70**. The illustrations and particular electrode configuration can vary according to system design.

FIGS. **50-61** depict various possible implementations for displaying ECG data on a display of a catheter placement system, such as the display **30** of the system **10** of FIG. **10** for instance, for assisting a clinician in placing a catheter into the vasculature of the patient **70**. In many of the implementations to follow, standard methods of presenting and displaying ECG data are improved to aid in catheter placement and confirmation of tip location. As such, the following display and computing techniques may be useful in presenting data to a clinician.

FIG. **50** shows that audible or other suitable feedback can be employed in connection with displaying an ECG trace, such as an ECG trace **1050** shown here, which is similar to the trace history window **182** depicted on the display screenshot **178** in FIG. **17**. In particular, in one embodiment a sound or other indicia can be correlated to an aspect of an ECG waveform of an ECG signal. In the present embodiment, an audible cue is associated with the amplitude of a P-wave **1052** of each waveform **176** in the ECG trace **1050**. As the P-wave amplitude changes as shown in FIG. **50**, the audible cue can correspondingly change. The audible cue can be modulated in frequency, volume, continuity (e.g., discrete click vs. a continuous tone), etc.

FIG. **51** shows a flow chart depicting one embodiment of a method for correlating and producing audible or other feedback with respect to an aspect of the ECG waveform **176**, such as the amplitude of the P-wave **1052**. This method in whole or in part can be performed and/or controlled by suitable components of the system **10**, e.g., circuitry included in the external sensor **50** or console **20**, or other suitable catheter or medical device placement system. In stage **1056**, ECG signal data is sampled in a manner such as has been described above in connection with use of the system **10** during catheter placement procedures. In stage **1058**, an ECG waveform is identified from the sampled ECG signal data. In stage **1060**, a P-wave portion of the ECG waveform is identified. This can be accomplished, for instance, by comparing portions of the waveform with a standard, pre-loaded P-wave template to determine the existence and location of the P-wave **1052**. The amplitude peak of the P-wave is then determined in stage **1062**. In stage **1064**, the P-wave amplitude peak is correlated to a corresponding audible or other suitable feedback output. This stage can be predetermined and stored by the system **10**, or can be dynamically controlled automatically or by user input, in one embodiment. The output is then produced in stage **1066**. Note that in other embodiments the output can be other than audible as has been described, including for instance visual, light/sound combinations, mechanical movement (vibratory), and/or other sensory cues, or combinations of the foregoing.

FIGS. **52-55** give further examples of visual output that can be correlated with aspects of ECG signal data, such as

P-wave amplitude of each detected ECG waveform, using the method depicted in FIG. **51**. For instance, FIG. **52** shows one display implementation wherein the P-wave **1052** of each ECG waveform **176** is identified and highlighted with a color to differentiate the P-wave from other portions of the waveform. In one embodiment, the color can change according to changes in P-wave amplitude.

In FIG. **53**, the peak amplitude of the P-wave **1052** in each waveform **176** is traced as a colored or shaded shadowing **1070** on the ECG trace **1050** as a function of time. In particular, during catheter insertion the P-waves **1052** of successive ECG waveforms **176** often vary in magnitude as the ECG sensor assembly of the catheter assembly (e.g., the catheter and/or stylet) approaches the SA node or other node of the heart. It is often useful to display the magnitude of the P-waves **1052** on the system display **30** as such changes take place. A line or colored bar can be used to trace out the magnitude of past peaks. In this way, a comparison between current and former peak magnitudes can be conveniently made. This display mode can be employed whether the trace move across the display or if the traces remain stationary and are refreshed by a moving bar that sweeps across the display.

FIG. **54** shows that once the P-wave **1052** falls below a previous level, another color or shade of shadowing **1070** can be used, as seen in the left-most portion of the ECG trace **1050** of FIG. **54**, to illustrate the difference between the most recent peaks and previous peaks. Optionally, a horizontal line **1054** can be used to trace out the peak of each P-wave **1052**, as in FIG. **55**. The line **1054** can be used either with or without the shadowing **1070**. Of course, many other such tracing implementations and visual indicia can be devised in accordance with these principles.

Reference is made to FIGS. **56A-57B** in describing aspects of scaling control of the ECG trace **150** as displayed in the trace history window **182** of the system display **30**, for instance. In typical ECG devices, the rate of ECG waveform display is constant. However, human heart rates are not constant and ECG waveform formation and spacing vary from person to person. It may be beneficial to the observer to be able to change the number of waveforms and/or amount of time waveforms are displayed on the system display **30** or other suitable device. This allows more or fewer ECG waveforms to be displayed. In one embodiment, the clinician can adjust display settings to determine how many ECG waveforms **176** are displayed or how much time the waveforms are to be displayed. In one embodiment, the user can select from a series of pre-determined, discrete display time or waveform options, or the settings can be user-defined. In another embodiment, the control over the display settings of the ECG trace **1050** can be dynamically or statically controlled autonomously by the system **10**.

As examples of the above ECG trace time window variability, FIG. **56A** shows the ECG waveforms **176** displayed as part of the ECG trace **1050** at a standard rate of four waveforms in the window, while FIG. **56B** shows an increased ECG trace window including eight waveforms. Similarly, FIG. **57A** shows ECG waveform data being displayed at a standard trace rate of five seconds, i.e., each waveform **176** remains displayed for approximately five seconds; while FIG. **57B** shows the ECG waveforms displayed at a relatively longer rate of approximately 10 seconds, i.e., double the standard trace rate, such that the peaks appear relatively closer together. As shown in FIGS. **56A-57B**, the physical width of the ECG trace window stays the same, with only the amount of waveforms displayed therein being modified.

FIG. 58 shows a flow chart depicting one embodiment of a method for displaying ECG signal data in the manner described above in connection with FIGS. 56A-57B. Note that this method in whole or in part can be performed and/or controlled by suitable components of the system 10, e.g., circuitry included in the external sensor 50 or console 20, or other suitable catheter or medical device placement system. In stage 1080, ECG signal data is sampled in a manner such as has been described above in connection with use of the system 10 during catheter placement procedures. In stage 1082, an ECG waveform, such as the waveform 176 in FIGS. 56A-57B, is identified from the sampled ECG signal data. In stage 1084, parameters of a display window, such as the trace history window 182 shown in FIG. 17 for displaying the ECG trace 1050 of FIGS. 56A-57B, are defined. These parameters may be, for instance, the number of ECG waveforms to be included in the window, or the amount of time each waveform remains on screen. As stage 1088 shows, the parameters can be user-defined or autonomously defined and controlled in a static (e.g., pre-set at factory) or dynamic (e.g., automatically adjusted by the system according to feedback) manner. It is appreciated that the parameters can concern other display aspects of the ECG trace or waveforms, including for example waveform height, line width, etc. Further the parameters can be defined such that zero, one, two, or more ECG waveforms are displayed in the trace window before being refreshed, for instance.

In stage 1085, the ECG waveform is displayed according to the defined display window parameters. As shown, in one embodiment stage 1085 can include stages 1086 and 1090. In stage 1086 the ECG waveform is combined with previous waveforms if permitted by the parameters defined in stage 1084. In stage 1090, the ECG waveform is displayed together with any previous waveforms as permitted by the parameters defined in stage 1084.

FIG. 59 shows an individual trace window wherein a single ECG waveform 176 is displayed and is periodically refreshed as new waveforms are identified by the system 10 during catheter placement procedures, as has been described. Such a trace window is used, for example, for the current ECG waveform window 180 and windows 184A, 184B, and 184 C of the system display 30, as reflected by the display screenshot 178 shown in FIG. 17. As has been described, the ECG waveform 176 includes the P-wave 1052, and a QRS complex 1096. A ratio between the magnitude of the peak of the P-wave 1052 and the magnitude of the QRS complex 1096 can be displayed in the trace window as a numeric (as shown in FIG. 59) or other suitable format to assist the clinician in determining the change of the ECG waveform as the catheter 72 is advanced through the vasculature of the patient 70. The ratio is updated as each new ECG waveform is depicted in the individual trace window.

FIG. 60 shows a flow chart depicting one embodiment of a method for displaying an ECG waveform in the manner described above in connection with FIG. 59. Note that this method in whole or in part can be performed and/or controlled by suitable components of the system 10, e.g., circuitry included in the external sensor 50 or console 20, or other suitable catheter or medical device placement system. In stage 1100, ECG signal data is sampled in a manner such as has been described above in connection with use of the system 10 during catheter placement procedures. In stage 1102, an ECG waveform, such as the waveform 176 in FIG. 59, is identified from the sampled ECG signal data. In stage 1104, a P-wave portion of the ECG waveform 176 is identified. This can be accomplished, for instance, by com-

paring portions of the waveform with a standard, pre-loaded P-wave template to determine the existence and location of the P-wave 1052.

In stage 1106, a ratio between the magnitude of the P-wave amplitude and a magnitude of the QRS complex amplitude 1096 is determined. In one embodiment, this stage may include determining the amplitude peak of the P-wave, identifying the QRS complex 1096 from the ECG waveform 176 and determining the magnitude of the QRS complex magnitude. In stage 1108, the ECG waveform 176 is displayed, such as in the current ECG waveform window 180 or one of the windows 184A, 184B, and 184 C of the system display 30 (FIG. 17). The waveform 176 can be displayed with the P-wave/QRS complex ratio data acquired via stage 1106, if desired. As shown in FIG. 60, the process flow can be looped so as to acquire and display new ECG waveforms as they are produced and detected.

Stage 1110 includes a freeze image input option, wherein a user can select the displayed ECG waveform 176 and freeze it in the display, thus interrupting the looping of the process flow, or optionally preventing newly-acquired waveforms from being displayed. Also, during the process flow stage 1112 can be executed, wherein data relating to the identified ECG waveform is sent to a storage location or device. The stored image can then be displayed if desired, such as in one of the windows 184A, 184B, and 184 C of the system display 30 (FIG. 17).

FIG. 61 shows one example of a catheter placement record 1114 that can be printed and used for record keeping/documentation purposes to verify proper placement of the catheter 72 within the vasculature of the patient 70. The record 1114 can include, in one embodiment, a beginning ECG waveform 176A representing the ECG waveform when the catheter 72 is first introduced into the patient vasculature, and a final ECG waveform 176B representing the ECG waveform when the distal end of the catheter is positioned in its desired location proximate the patient's heart or other suitable location. An image representation 120 of the sensor 50 can be included with a stylet distal end icon 114 depicted on the sensor image to represent final placement of the stylet, and thus catheter as well. Date, time, patient ID, etc. can also be included in the record 1114. In one embodiment, a location for the clinician or responsible party to sign can also be included. The record 1114 can be user-modifiable via the system 10 in one embodiment so as to allow for customization for various hospital and clinic procedures and requirements. Printout of the record 1114 can be performed via an appropriate button included on the US probe 40, system console 20, etc. In another embodiment, the foot-switch 1116 shown in FIG. 27 or other suitable interface can be used to capture and print the record 1114, if desired.

FIG. 62 shows yet another example of the catheter placement record 1114 that can be printed and used for record keeping/documentation purposes to verify proper placement of the catheter 72. The record 1114 can include, in one embodiment, three windows, with each window depicting the sensor image 120 and selected tip location and ECG waveform data. For instance, the record 1114 in FIG. 62 shows a left window including the beginning ECG waveform 176A and the corresponding ECG trace 1050 when the catheter 72 is first introduced to the vasculature, a middle window including the revised ECG trace 1050 and an intermediate ECG waveform 176C representing the ECG waveform when the catheter is positioned as indicated by the stylet distal end icon 114, and a right window including the updated ECG trace 1050 and final position ECG waveform 176B representing the ECG waveform when the catheter is

finally positioned as indicated by the stylet distal end icon 114. Of course, other configurations/information can be included in the record.

The various data acquired via use of the system 10 as described herein can be stored and/or evaluated for current or later use. In particular, in one embodiment both the TLS magnetic element tracking data and ECG signal detection data acquired via use of the system 10 can be stored for use as appreciated by those skilled in the art. In one embodiment, the TLS magnetic element tracking data for the catheter 72 and the ECG signal detection data can be associated with catheter position within the vasculature as a function of time so that a record of the catheter placement can be constructed in real time or at a later time via storage of the data. Such data can be stored in real time during the catheter placement procedure to operate as a fail-safe mode should the system temporarily and unexpectedly shut down during placement. Further, the data can be useful to pinpoint stylet position relative to the peak P-wave amplitude of the ECG signal by calculating the distance between the current stylet distal tip position and the position where P-wave amplitude is maximized. The data can also be employed to provide three dimensional information regarding the path along which the catheter is advanced within the patient vasculature.

Embodiments of the present invention may comprise a special purpose or general-purpose computer including computer hardware. Embodiments within the scope of the present disclosure also include computer-readable media for carrying or having computer-executable instructions or data structures stored thereon. Such computer-readable media can be any available media that can be accessed by a general purpose or special purpose computer. By way of example, and not limitation, computer-readable media can include physical (or recordable-type) computer-readable storage media, such as, RAM, ROM, EEPROM, CD-ROM or other optical disk storage, magnetic disk storage or other magnetic storage devices, non-volatile and flash memory, or any other medium which can be used to store desired program code means in the form of computer-executable instructions or data structures and which can be accessed by a general purpose or special purpose computer.

In this description and in the following claims, a "network" is defined as one or more data links that enable the transport of electronic data between computer systems and/or modules. When information is transferred or provided over a network or another communications connection (either hardwired, wireless, or a combination of hardwired or wireless) to a computer, the computer properly views the connection as a computer-readable medium. Thus, by way of example, and not limitation, computer-readable media can also include a network or data links which can be used to carry or store desired program code means in the form of computer-executable instructions or data structures and which can be accessed by a general purpose or special purpose computer.

Computer-executable instructions comprise, for example, instructions and data which cause a general purpose computer, special purpose computer, or special purpose processing device to perform a certain function or group of functions. The computer executable instructions may be, for example, binaries, intermediate format instructions such as assembly language, or even source code. Although the subject matter has been described in language specific to structural features and/or methodological acts, it is to be understood that the subject matter defined in the appended claims is not necessarily limited to the described features or

acts described above. Rather, the described features and acts are disclosed as example forms of implementing the claims.

Those skilled in the art will appreciate that the embodiments of the present invention may be practiced in computing environments with one or more types of computer system configurations, including, personal computers, desktop computers, laptop computers, message processors, handheld devices, multi-processor systems, microprocessor-based or programmable consumer electronics, network PCs, minicomputers, mainframe computers, mobile telephones, PDAs, pagers, and the like. Embodiments may also be practiced in distributed system environments where local and remote computer systems, which are linked (either by hardwired data links, wireless data links, or by a combination of hardwired and wireless data links) through a network, both perform tasks. In a distributed system environment, program modules may be located in both local and remote memory storage devices.

Embodiments of the invention may be embodied in other specific forms without departing from the spirit of the present disclosure. The described embodiments are to be considered in all respects only as illustrative, not restrictive. The scope of the embodiments is, therefore, indicated by the appended claims rather than by the foregoing description. All changes that come within the meaning and range of equivalency of the claims are to be embraced within their scope.

What is claimed is:

1. A method for displaying ECG signal data of a node of a patient, comprising:
 - detecting the ECG signal data with an ECG sensor component at least partially disposed in the patient, the ECG sensor component having a processor and being included in a catheter placement system;
 - sampling the ECG signal data;
 - identifying a first ECG waveform and a second ECG waveform from the sampled ECG signal data by the processor of the ECG sensor component;
 - defining at least one parameter of a display window of the catheter placement system; and
 - displaying the first ECG waveform and the second ECG waveform in the display window according to the at least one parameter of the display window, wherein displaying the first ECG waveform and the second ECG waveform includes: displaying (i) a first horizontal line that traces a peak of a P-wave portion of the first ECG waveform having a first amplitude; and (ii) a second horizontal line that traces a peak of a P-wave portion of the second ECG waveform having a second amplitude, the second amplitude being different than the first amplitude.
2. The method for displaying according to claim 1, wherein displaying the first ECG waveform further comprises:
 - combining, by the processor, the first ECG waveform with at least one previous ECG waveform when permitted by the at least one parameter of the display window; and
 - displaying the first ECG waveform with the at least one previous ECG waveform in the display window when permitted by the at least one parameter of the display window.
3. The method for displaying according to claim 1, wherein defining the at least one parameter further comprises defining the at least one parameter of the display window according to at least one of a user-defined control and an autonomous control.

4. The method for displaying according to claim 1, wherein the display window is included on a visual display of a console of the catheter placement system.

5. The method for displaying according to claim 1, wherein defining the at least one parameter further comprises defining a number of ECG waveforms to be included in the display window.

6. The method for displaying according to claim 1, wherein defining the at least one parameter further comprises defining an amount of time each ECG waveform is to be shown in the display window.

7. A method for displaying an ECG waveform of a node of a patient, comprising:

detecting ECG signal data with an ECG sensor component at least partially disposed in the patient, the ECG sensor component having a processor and being included in a catheter placement system;

sampling the ECG signal data;

identifying a first ECG waveform and a second ECG waveform from the sampled ECG signal data by the processor of the ECG sensor component;

identifying a characteristic of the first ECG waveform and a characteristic of the second ECG waveform by the processor of the ECG sensor component; and

displaying the first ECG waveform and the second ECG waveform in a display window of the catheter placement system, wherein displaying the first ECG waveform and the second ECG waveform includes: displaying (i) a first horizontal line that traces a peak of the characteristic of the first ECG waveform having a first amplitude and; (ii) a second horizontal line that traces a peak of the characteristic of the second ECG wave-

form having a second amplitude, the second amplitude being different than the first amplitude.

8. The method for displaying according to claim 7, wherein identifying the P-wave portion of the first ECG waveform and the P-wave portion of the second ECG waveform includes comparing a portion of the first ECG waveform and a portion of the second ECG waveform with a known P-wave template.

9. The method for displaying according to claim 7, further comprising:

identifying a QRS complex of the first ECG waveform with the catheter placement system;

determining a ratio between a magnitude of the P-wave portion of the first ECG waveform and a magnitude of the QRS complex of the first ECG waveform; and displaying the first ECG waveform with data relating to the ratio.

10. The method for displaying according to claim 7, further comprising freezing the ECG waveform on the display window of the catheter placement system in response to user input.

11. The method for displaying according to claim 7, further comprising storing data relating to the first ECG waveform in a storage location.

12. The method for displaying according to claim 7, wherein the method is looped to display successive ECG waveforms.

13. The method for displaying according to claim 7, further comprising producing audible or visual output in response to a characteristic of the first ECG waveform.

* * * * *

专利名称(译)	与血管内放置导管有关的装置和显示方法		
公开(公告)号	US9549685	公开(公告)日	2017-01-24
申请号	US14/498887	申请日	2014-09-26
申请(专利权)人(译)	C.R. BARD , INC.		
当前申请(专利权)人(译)	C. R. BARD , INC.		
[标]发明人	COX JEREMY B CROOK CHRISTIAN W		
发明人	COX, JEREMY B. CROOK, CHRISTIAN W.		
IPC分类号	A61B5/042 A61B5/06 A61B8/08 A61B5/0472 A61B5/00		
CPC分类号	A61B5/0472 A61B5/06 A61B5/061 A61B8/0833 A61B8/0841 A61B34/20 A61B5/042 A61B5/742 A61B46/00 A61B90/40 A61B2034/2051 A61B2090/378		
代理机构(译)	鲁坦和塔克LLP		
优先权	61/095921 2008-09-10 US 61/045944 2008-04-17 US 61/091233 2008-08-22 US 61/095451 2008-09-09 US 60/990242 2007-11-26 US		
其他公开文献	US20150018701A1		
外部链接	Espacenet USPTO		

摘要(译)

公开了一种用于将导管精确地放置在患者脉管系统内的集成导管放置系统。在一个实施例中，集成系统包括系统控制台，用于临时放置在患者胸部上的尖端位置传感器，以及超声探头。当导管设置在脉管系统中时，尖端位置传感器感测设置在导管内腔中的探针的磁场。超声探头在引入导管之前对脉管系统的一部分进行超声成像。基于ECG信号的导管尖端引导包括在集成系统中，以使导管尖端能够相对于患者心脏的节点引导到期望的位置。还公开了用于可视化和操纵经由本系统获取的ECG信号数据的显示的各个方面，以及各种ECG传感器配置的各方面。

