



US009326697B2

(12) **United States Patent**
Linker

(10) **Patent No.:** **US 9,326,697 B2**
(45) **Date of Patent:** **May 3, 2016**

(54) **LONG-TERM MONITORING FOR DISCRIMINATION OF DIFFERENT HEART RHYTHMS**

(2013.01); *A61B 5/04325* (2013.01); *A61B 5/0006* (2013.01); *A61B 2560/0412* (2013.01);
(Continued)

(71) Applicant: **University of Washington**, Seattle, WA (US)

(58) **Field of Classification Search**
CPC *A61B 5/04012*; *A61B 5/0402*; *A61B 5/0452*; *A61B 5/0472*
See application file for complete search history.

(72) Inventor: **David Thor Linker**, Seattle, WA (US)

(73) Assignee: **University of Washington**, Seattle, WA (US)

(56) **References Cited**

U.S. PATENT DOCUMENTS

(*) Notice: Subject to any disclaimer, the term of this patent is extended or adjusted under 35 U.S.C. 154(b) by 0 days.

4,248,244 A 2/1981 Charnitski
5,348,008 A 9/1994 Bomn
(Continued)

(21) Appl. No.: **14/315,061**

FOREIGN PATENT DOCUMENTS

(22) Filed: **Jun. 25, 2014**

EP 1 219 237 A2 7/2002
GB 2 310 925 A 10/1997

(65) **Prior Publication Data**

US 2015/0141860 A1 May 21, 2015

(Continued)

OTHER PUBLICATIONS

Ang, N.H., "Real-Time Electrocardiogram Signal Processing for Atrial Fibrillation Detection," Final report of the Postgraduate Programme: Mathematics for Industry, Stan Ackermans Institute, Eindhoven University of Technology, Netherlands, 2004, 53 pages.

(Continued)

Related U.S. Application Data

(63) Continuation of application No. 13/670,246, filed on Nov. 6, 2012, now Pat. No. 8,798,727, which is a continuation of application No. 12/125,859, filed on May 22, 2008, now Pat. No. 8,326,407, which is a continuation-in-part of application No. 11/253,375, filed on Oct. 19, 2005, now Pat. No. 7,630,756.

Primary Examiner — Joseph Dietrich

(74) *Attorney, Agent, or Firm* — Christensen O'Connor Johnson Kindness PLLC

(60) Provisional application No. 60/620,598, filed on Oct. 19, 2004.

(57) **ABSTRACT**

A method, system, and device for detection of an arrhythmia, and discrimination between different types of arrhythmia, for example to determine whether to administer an electric shock to the heart, the device comprising a wearable monitor with electrodes that detect the electrical activity of a beating heart, attached to an embedded monitoring system having an amplifier, a microprocessor, a data storage device, and a power supply, all disposed on a substrate having large distal end portions that attach to the electrodes and a narrow intermediate portion that attaches to the monitoring system.

(51) **Int. Cl.**
A61B 5/0452 (2006.01)
A61B 5/046 (2006.01)
(Continued)

16 Claims, 14 Drawing Sheets

(52) **U.S. Cl.**
CPC *A61B 5/046* (2013.01); *A61B 5/0031* (2013.01); *A61B 5/02405* (2013.01); *A61B 5/0432* (2013.01); *A61B 5/0468* (2013.01); *A61B 5/0472* (2013.01); *A61B 5/04085*

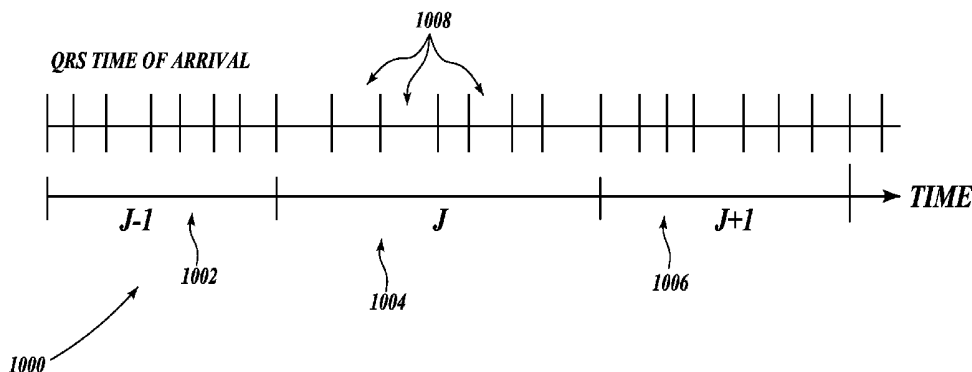

- (51) **Int. Cl.**
A61B 5/024 (2006.01)
A61B 5/0432 (2006.01)
A61B 5/0408 (2006.01)
A61B 5/0468 (2006.01)
A61B 5/0472 (2006.01)
A61B 5/00 (2006.01)
A61N 1/362 (2006.01)
A61N 1/37 (2006.01)
- (52) **U.S. Cl.**
 CPC *A61B2560/0456* (2013.01); *A61N 1/3621*
 (2013.01); *A61N 1/3702* (2013.01)

(56) **References Cited**

U.S. PATENT DOCUMENTS

6,487,442	B1	11/2002	Wood
6,701,183	B2	3/2004	Baker
6,705,998	B2	3/2004	Stergiopoulos
7,094,207	B1	8/2006	Koh
2002/0052557	A1	5/2002	Griffin
2002/0143259	A1	10/2002	Stergiopoulos
2002/0147409	A1	10/2002	Baker
2002/0151806	A1	10/2002	Starobin
2003/0130586	A1	7/2003	Starobin
2006/0084883	A1	4/2006	Linker
2006/0089559	A1	4/2006	Barbieri
2006/0167361	A1	7/2006	Bennett
2007/0179390	A1	8/2007	Schechter

FOREIGN PATENT DOCUMENTS

WO	02/056961	A2	7/2002
WO	03/105020	A2	12/2003
WO	2009/070798	A1	6/2009
WO	2011/023446	A1	3/2011

OTHER PUBLICATIONS

Bassingthwaighe, J.B., and G.M. Raymond, "Evaluation of the Dispersional Analysis Method for Fractal Time Series," *Annals of Biomedical Engineering* 23(4):491-505, 1995.

Duverney, D., et al., "High Accuracy of Automatic Detection of Atrial Fibrillation Using Wavelet Transform of Heart Rate Intervals," *Pacing and Clinical Electrophysiology* 25(4, Part 1):457-462, Apr. 2002. "Geratherm Awarded Licence for Cardio Monitor," Geratherm Medical AG, May 26, 2004, <http://www.geratherm.com/en/iv_pressemittelungen>, 4 pages [retrieved Jan. 26, 2006].

"How It Works," © 2002 CardioNet, <<http://www.cardionet/how.html>>, 1 page [retrieved Jan. 26, 2006].

Instromedix, A Card Guard Company, © 2004 Card Guard® Group of Companies, <<http://www.instromedix.com>>, 1 page [retrieved Jan. 26, 2006].

Israel, C.W., et al., "Long-Term Risk of Recurrent Atrial Fibrillation as Documented by an Implantable Monitoring Device: Implications for Optimal Patient Care," *Journal of the American College of Cardiology* 43(1):47-52, 2004.

Malik, M., "Heart Rate Variability. Standards of Measurement, Physiological Interpretation, and Clinical Use," *European Heart Journal* 17(3):354-381, Mar. 1996.

Page, R.L., et al., "Asymptomatic or 'Silent' Atrial Fibrillation: Frequency in Untreated Patients and Patients Receiving Azimilide," *Circulation* 107(8):1141-1145, 2003.

Swerdlow, C.D., et al., "Detection of Atrial Fibrillation and Flutter by a Dual Chamber Implantable Cardioverter-Defibrillator," *Circulation* 101(8):878-885, 2000.

Tateno, K., and L. Glass, "Automatic Detection of Atrial Fibrillation Using the Coefficient of Variation and Density Histograms of RR and ARR Intervals," *Medical and Biological Engineering and Computing* 39(6):664-671, 2001.

Wolk, R., et al., "The Incidence of Asymptomatic Paroxysmal Atrial Fibrillation in Patients Treated With Propranolol or Propafenone," *International Journal of Cardiology* 54(3):207-211, 1996.

European Search Report mailed Sep. 28, 2009, issued in corresponding European Patent Application No. EP 05809951.6, filed Oct. 19, 2005, 2 pages.

European Examination Report mailed Jan. 13, 2010, issued in corresponding European Patent Application No. EP 05809951.6, filed Oct. 19, 2005, 11 pages.

International Search Report and Written Opinion mailed Jan. 20, 2010, issued in corresponding International Application No. PCT/US2009/044957, filed May 22, 2009, 6 pages.

Alter, P., et al., "Complications of Implantable Cardioverter Defibrillation Therapy in 440 Consecutive Patients," *Pacing and Clinical Electrophysiology* 28(9):926-932, Sep. 2005.

Buttsworth, D.R., et al., "Skin Friction Measurements on Reflective Surfaces Using Nematic Liquid Crystal," *Experiments in Fluids* 28(1):64-73, Jan. 2000.

Cebrián, A., et al., "Implantable Cardioverter Defibrillator Algorithms: Status Review in Terms of Computational Cost," *Biomedizinische Technik (Biomedical Engineering)* 52(1):25-30, Feb. 2007.

Chandrasekaran, V., et al., "Dynamic Calibration Technique for Thermal Shear Stress With Variable Mean Flow," *Proceedings of the 38th Aerospace Sciences Meeting & Exhibit*, Reno, Nev., Jan. 10-13, 2000, 10 pages.

Chapman, D.P., "Pressure Sensitive Paint Using Platinum Porphyrin Sensor and Silicon Porphyrin Reference," Master's Thesis, University of Washington, Jun. 11, 1998, 73 pages.

Chong, T.P., and S. Zhong, "On the Shear Stress and Thermal Footprints of Turbulent Spots at Zero Pressure Gradient," *Journal of Mechanical Science and Technology* 27(4):1001-1009, Apr. 2013.

Costa, R., et al., "Incidence and Shock of Quality of Life in Young Patients With Implantable Cardioverter-Defibrillator," *Arquivos Brasileiros de Cardiologia* 88(3):258-264, Mar. 2007.

De Boer, J.F., et al., "Determination of the Depth-Resolved Stokes Parameters of Light Backscattered From Turbid Media by Use of Polarization-Sensitive Optical Coherence Tomography," *Optics Letters* 24(5):300-302, Mar. 1999.

De Boer, J.F., et al., "Two-Dimensional Birefringence Imaging in Biological Tissue by Polarization-Sensitive Optical Coherence Tomography," *Optics Letters* 22(12):934-936, Jun. 1997.

Elvery, D.G., and K. Bremhorst, "Directional Sensitivity of Wall Mounted Hot-Film Gauges," *Measurement Science and Technology* 7(10):1410-1417, Oct. 1996.

Extended European Search Report mailed Mar. 21, 2012, issued in European Application No. EP 12 151 997.9, filed Oct. 19, 2005, 11 pages.

Extended European Search Report mailed Dec. 20, 2012, issued in European Application No. EP 12 151 997.9, filed Oct. 19, 2005, 5 pages.

Extended European Search Report mailed Jun. 28, 2013, issued in European Application No. EP 09 763 214.5, filed May 22, 2009, 6 pages.

Feinberg, W.M., et al., "Prevalence, Age Distribution, and Gender of Patients With Atrial Fibrillation," *Archives of Internal Medicine* 155(5):469-473, Mar. 1995.

Formentin, P., et al., "Polymer-Dispersed Liquid Crystal Based on E7: Morphology and Characterization," *Synthetic Metals* 158(21-24):1004-1008, Dec. 2008.

Fourquette, D., et al., "Miniature and MOEMS Flow Sensors," *Proceedings of the 31st AIAA Fluid Dynamics Conference and Exhibit*, Anaheim, Calif., Jun. 11-14, 2001, 9 pages.

"From Analysis to Action: Undergraduate Education in Science, Mathematics, Engineering, and Technology—Report of a Convocation," Center for Science, Mathematics, and Engineering Education, National Research Council, National Academy Press, Washington, D.C., 1996, 43 pages.

Fujisawa, M., et al., "Measurements of Wall-Shear-Stress Distribution on an NACA0018 Airfoil by Liquid-Crystal Coating and Near-Wall Particle Image Velocimetry (PIV)," *Measurement Science and Technology* 20(6):065403, Jun. 2009, 10 pages.

(56)

References Cited

OTHER PUBLICATIONS

- Fuster, V., et al., "ACC/AHA/ESC Guidelines for the Management of Patients With Atrial Fibrillation," *European Heart Journal* 22(20):1852-1923, Oct. 2001.
- Geday, M.A., et al., "Images of Absolute Retardance $L \cdot \Delta n$, Using the Rotating Polariser Method," *Journal of Microscopy* 198(1):1-9, Apr. 2000.
- George, M.D., et al., "Shaping the Future: New Expectations for Undergraduate Education in Science, Mathematics, Engineering, and Technology," A Report on Its Review of Undergraduate Education by the Advisory Committee to the National Science Foundation Directorate for Education and Human Resources, Oct. 3, 1996, 73 pages.
- Glazer, A.M., et al., "An Automatic Optical Imaging System for Birefringent Media," *Proceedings: Mathematical, Physical and Engineering Sciences* 452(1955):2751-2765, Dec. 1996.
- Go, A.S., et al., "Prevalence of Diagnosed Atrial Fibrillation in Adults: National Implications for Rhythm Management and Stroke Prevention: The Anticoagulation and Risk Factors in Atrial Fibrillation (ATRIA) Study," *Journal of the American Medical Association (JAMA)* 285(18):2370-2375, May 2001.
- Goldberg, H.D., et al., "A Silicon Wafer-Bonding Technology for Microfabricated Shear-Stress Sensors With Backside Contacts," *Solid-State Sensor and Actuator Workshop*, Hilton Head, S.C., Jun. 13-16, 1994, pp. 111-115.
- Goldberger A.L., et al., "MIT-BIH Atrial Fibrillation Database" [Online], doi:10.13026/C2MW2D, "PhysioBank, PhysioToolkit, and PhysioNet: Components of a New Research Resource for Complex Physiologic Signals," *Circulation* 101(23):e215-e220, Jun. 2000. <<http://www.physionet.org/physiobank/database/afdb/>> [retrieved Nov. 11, 2015], 5 pages.
- Goldberger A.L., et al., "MIT-BIH Normal Sinus Rhythm Database" [Online], doi:10.13026/C2NK5R, "PhysioBank, PhysioToolkit, and PhysioNet: Components of a New Research Resource for Complex Physiologic Signals," *Circulation* 101(23):e215-e220, Jun. 2000. <<http://www.physionet.org/physiobank/database/afdb/>> [retrieved Nov. 11, 2015], 4 pages.
- Große, S., and W. Schröder, "Mean Wall-Shear Stress Measurements Using the Micro-Pillar Shear-Stress Sensor MPS," *Measurement Science and Technology* 19(1):01504, Nov. 2007, 12 pages.
- Große, S., and W. Schröder, "Two-Dimensional Visualization of Turbulent Wall Shear," *AIAA Journal* 47(2):1-8, Feb. 2009.
- Hamza, A.A., et al., "Spectral Dispersion Curves of Polymeric Birefringent Textile Fibers," *Journal of Applied Polymer Science* 84(13):2481-2488, Jun. 2002.
- Haritonidis, J.H., "The Measurement of Wall Shear Stress," in "Advances in Fluid Mechanics Measurements," Springer-Verlag: Berlin and New York, 1989, pp. 229-261.
- Haselbach, F., and W. Nitsche, "Calibration of Single-Surface Hot Films and In-Line Hot-Film Arrays in Laminar or Turbulent Flows," *Measurement Science and Technology* 7(10):1428-1428, Oct. 1996.
- Hites, M., et al., "Velocity and Wall Shear-Stress Measurements in High-Reynolds-Number Turbulent Boundary Layers," *Proceedings of the 28th Fluid Dynamics Conference*, Snowmass Village, Colo., Jun. 29-Jul. 2, 1997, 14 pages.
- Hyman, D., et al., "Microfabricated Shear Stress Sensors, Part 2: Testing and Calibration," *AIAA Journal* 37(1):1-6, Jan. 1999.
- Iijima, Y., and H. Sakaue, "Platinum Porphyrin and Luminescent Polymer for Two-Color Pressure- and Temperature-Sensing Probes," *Sensors and Actuators A: Physical* 184:128-133, Sep. 2012.
- Jewett, D., "New Paint Helps Ford Get Handle on Air Pressure," *Automotive News* 75(5937):18D, Jul. 2001.
- Jiang, F., et al., "A Surface-Micromachined Shear Stress Imager," *Proceedings of the Ninth Annual International Workshop on Micro Electro Mechanical Systems (MEMS): An Investigation of Micro Structures, Sensors, Actuators, Machines and Systems*, San Diego, Feb. 11-15, 1996, pp. 110-115.
- Kaminsky, W., et al., "Simultaneous False-Colour Imaging of Birefringence, Extinction and Transmittance at Camera Speed," *Journal of Microscopy* 228(2):153-164, Nov. 2007.
- Kimura, F.M., "Novel Measurement Techniques for the Study of Unsteady Flow Phenomena: Shear Sensitive Paint and Pressure Sensitive Microspheres," *Doctors Dissertation*, University of Washington, 2009, 227 pages.
- Klein, G.J., et al., "Improving SVT Discrimination in Single-Chamber ICDs: A New Electrogram Morphology-Based Algorithm," *Journal of Cardiovascular Electrophysiology* 17(12):1310-1319, Dec. 2006.
- Lavitt, M.O., "Industry Outlook," *Aviation Week & Space Technology*, Oct. 18, 1993, p. 23.
- Li, G.S., "Shear-Sensitive Polymer Dispersed Liquid Crystal," *Master's Thesis*, University of Washington, 2012, 55 pages.
- LIN, H.J., et al., "Newly Diagnosed Atrial Fibrillation and Acute Stroke, The Framingham Study," *Stroke* 26(9):1527-1530, Sep. 1995.
- Litwin, D., and A.M. Sadik, "Measurement of Birefringence of Textile Fibers Based on the Analysis of Interference Pattern in the Back Focal Plane of the Microscope Objective," *SPIE Conference on Laser Interferometry IX: Applications*, San Diego, Jul. 1998, vol. 3479, pp. 160-169.
- Löfdahl, L., and M. Gad-El-Hak, "MEMS Applications in Turbulence and Flow Control," *Progress in Aerospace Sciences* 35(2):101-203, Feb. 1999.
- Mateer, G.G., and D.J. Monson, "Skin-Friction Measurements and Calculations on a Lifting Airfoil," *AIAA Journal* 34(2):231-236, Feb. 1996.
- Mei, G., and R. Oldenbourg, "Fast Imaging Polarimetry With Precision Universal Compensator," *Proceedings of the SPIE* 2265:29-39, Sep. 1994.
- Miletzko, R., et al., "Enhanced Specificity of a Dual Chamber ICD Arrhythmia Detection Algorithm by Rate Stability Criteria," *Pacing and Clinical Electrophysiology* 27(8):1113-1119, Aug. 2004.
- Monson, D.J., et al., "Boundary-Layer Transition and Global Skin Friction Measurement With an Oil-Fringe Imaging Technique," *NASA, SAE Aerotech '93*, Costa Mesa, Calif., Sep. 27-30, 1993, Paper No. 932550, 16 pages.
- Naqwi, A.A., and W.C. Reynolds, "Dual Cylindrical Wave Laser-Doppler Method for Measurement of Skin Friction in Fluid Flow," Prepared under the joint support of Army Research Office, Aeromechanics Laboratory, RIL (AVRADCOM) NASA-Ames Research Center, Report No. TF-28, Thermosciences Division, Department of Mechanical Engineering, Stanford University, Stanford, Calif., Jan. 1987, 286 pages.
- National Science Education Standards, National Academy Press, Washington, D.C., 1996, 272 pages.
- Naughton, J.W., and M. Sheplak, "Modern Developments in Shear-Stress Measurement," *Progress in Aerospace Sciences* 38(6-7):515-570, Aug.-Oct. 2002.
- Ng, K.-Y., et al., "A Liquid Shear-Stress Sensor Fabricated Using Wafer Bonding Technology," *International Conference on Solid-State Sensors and Actuators (TRANSDUCERS '91)*, San Francisco, Jun. 24-27, 1991, pp. 931-934.
- Noguchi, M., et al., "Measurement of 2-D Birefringence Distribution," *Proceedings of the SPIE* 1720:367-378, Oct. 1992.
- Oldenbourg, R., and G. Mei, "New Polarized Light Microscope With Precision Universal Compensator," *Journal of Microscopy* 180(2):140-147, Nov. 1995.
- Otani, Y., et al., "Two-Dimensional Birefringence Measurement Using the Phase Shifting Technique," *Optical Engineering* 33(5):1604-1609, May 1994.
- Owen, R.L., and E. Garman, "A New Method for Predetermining the Diffraction Quality of Protein Crystals: Using Soap as a Selection Tool," *Acta Crystallographica Section D: Biological Crystallography* 6(2):130-140, Feb. 2005.
- Padmanabhan, A., "Silicon Micromachined Sensors and Sensor Arrays for Shear-Stress Measurements in Aerodynamic Flows," *doctoral dissertation*, Massachusetts Institute of Technology, Feb. 1997, 177 pages.
- Padmanabhan, A., et al., "Micromachined Sensors for Static and Dynamic Shear-Stress Measurements in Aerodynamic Flows," *Proceedings of the International Conference on Solid-State Sensors and Actuators (Transducers '97)*, Chicago, Jun. 16-19, 1997, pp. 137-140.

(56)

References Cited

OTHER PUBLICATIONS

- Padmanabhan, A., et al., "A Silicon Micromachined Sensor for Shear Stress Measurements in Aerodynamic," Proceedings of the AIAA 34th Aerospace Sciences Meeting and Exhibit, Reno, Nev., Jan. 15-18, 1996, AIAA Paper 96-0422, 12 pages.
- Padmanabhan, A., et al., "A Wafer-Bonded Floating-Element Shear Stress Microsensor With Optical Position Sensing by Photodiodes," *Journal of Microelectromechanical Systems* 5(4):307-315, Dec. 1996.
- Pan, T., et al., "Microfabricated Shear Stress Sensors, Part 1: Design and Fabrication," *AIAA Journal* 37(1):66-72, Jan. 1999.
- Parmar, D.S., and J.J. Singh, "Partially Exposed Polymer Dispersed Liquid Crystals for Boundary Layer Investigations," *Applied Physics Letters* 61(17):2039-2041, Oct. 1992.
- Reda, D.C., "Liquid Crystals Indicate Directions of Surface Shear Stresses," NASA Tech Briefs, May 1996, pp. 89-90.
- Reda, D.C., and M.C. Wilder, "Shear-Sensitive Liquid Crystal Coating Method Applied Through Transparent Test Surfaces," *AIAA Journal* 39(1):195-197, Jan. 2001.
- Reda, D.C., et al., "Measurement of Continuous Pressure and Shear Distributions Using Coatings and Imaging Techniques," *AIAA Journal* 36(6):895-899, Jun. 1998.
- Reda, D.C., et al., "New Methodology for the Measurement of Surface Shear Stress Vector Distributions," *AIAA Journal* 35(4):608-614, Apr. 1997.
- Reda, D.C., et al., "Time and Flow-Direction Responses of Shear-Stress-Sensitive Liquid Crystal Coatings," *AIAA Journal* 32(4):693-700, Apr. 1994.
- Sakaue, H., et al., "A Motion-Capturing Pressure-Sensitive Paint Method," *Journal of Applied Physics* 133(8):084901-1-084901-8, Feb. 2013.
- Saxer, C.E., et al., "High-Speed Fiber-Based Polarization-Sensitive Optical Coherence Tomography of In Vivo Human Skin," *Optics Letters* 25(18):1355-1357, Sep. 2000.
- Schmidt, M.A., et al., "Design and Calibration of a Microfabricated Floating-Element Shear-Stress Sensor," *IEEE Transactions on Electron Devices* 35(6):750-757, Jun. 1988.
- "Science and Engineering Education for the 1980s and Beyond," Department of Education, Washington, D.C.; National Science Foundation, Washington, D.C., Oct. 1980, 227 pages.
- Shajii, J., et al., "A Microfabricated Floating-Element Shear Stress Sensor Using Wafer-Bonding Technology," *Journal of Microelectromechanical Systems* 1(2):89-94, Jun. 1992.
- Sheplak, M., et al., "Dynamic Calibration of a Shear-Stress Sensor Using Stokes-Layer Excitation," *AIAA Journal* 39(5):819-823, May 2001.
- Shribak M. and R. Oldenbourg, "Techniques for Fast and Sensitive Measurements of Two-Dimensional Birefringence Distributions," *Applied Optics* 42(16):3009-3017, Jun. 2003.
- Shribak, M.I., "Autocollimating Detectors of Birefringence," Proceedings of the SPIE 2782:805-813, Sep. 1996.
- Shribak, M.I., et al., "Return-Path Polarimeter for Two Dimensional Birefringence Distribution Measurement," Proceedings of the SPIE 3754:144-149, Oct. 1999.
- Spiesz, E.M., et al., "A Quantitative Collagen Fibers Orientation Assessment Using Birefringence Measurements: Calibration and Application to Human Osteons," *Journal of Structural Biology* 176(3):302-306, Dec. 2011.
- Squire, L.C., "The Motion of a Thin Oil Sheet Under the Boundary Layer on a Body," in R.L. Maltby (ed.), "Flow Visualization in Wind Tunnels Using Indicators," Atlantic Treaty Organization Aeronautical Research and Development, Paris (AGARDograph 70), Apr. 1962, pp. 7-28.
- Squire, L.C., "The Motion of a Thin Oil Sheet Under the Steady Boundary Layer on a Body," *Fluid Mechanics* 11(02):161-179, Sep. 1, 1961.
- Sumana, G., and K.K. Raina, "Effect of Polymer Concentration on Polarization Switching in Polysiloxane-Dispersed Ferroelectric Liquid Crystals," *Journal of Applied Physics* 87(8):1209-1215, Feb. 2003.
- Tanner, L.H., and L.G. Blows, "A Study of the Motion of Oil Films on Surfaces in Air Flow, With Application to the Measurement of Skin Friction," *Journal of Physics E: Scientific Instruments* 9(3):194-202, Mar. 1976.
- Tanner, L.H., and V.G. Kulkarni, "The Viscosity Balance Method of Skin Friction Measurement: Further Developments Including Applications to Three-Dimensional Flow," *Journal of Physics E: Scientific Instruments* 9(12):1114-1121, Dec. 1976.
- Tropea, C., et al., "Wall-Bounded Flows," in "Springer Handbook of Experimental Fluid Mechanics," Springer-Verlag: Berlin, 2007, pp. 871-907.
- Velez, H.A., "Identification Characteristics of PLA Fibers: A New Generic Fiber Type," *Forensic Science Communications* 5(3):1-6, Jul. 2003.
- West, J.L., et al., "Fast Birefringent Mode Stressed Liquid Crystal," *Applied Physics Letters* 86(3):031111-1-331111-3, 2005.
- Winter, K.G., "An Outline of the Techniques Available for the Measurement of Skin Friction in Turbulent Boundary Layers," *Progress in Aerospace Sciences* 18:1-57, 1979.
- Yen, W.-H., et al., "Polarization Microscopy of Magnetic Domains for Magneto-Optical Disks," *Applied Optics* 38(17):3749-3758, Jun. 1999.
- Zeitner, U.D., et al., "Micro-Optical Sensor System for Birefringence Characterization of Textile Fibers," Proceedings of SPIE 5183:89-84, Nov. 2003.
- Zhao, J.-S., et al., "Measurement of Surface Shear Stress Vector Distribution Using Shear-Sensitive Liquid crystal Coatings," *Acta Mechanica Sinica* 28(5):1261-1270, Oct. 2012.
- Zhu, Y., et al., "Two-Dimensional Measurement Technique for Birefringence Vector Distributions: Measurement Principle," *Applied Optics* 38(11):2225-2231, Apr. 1999.
- Zhu, Y., et al., "Two-Dimensional Optical Measurement Techniques Based on Optical Birefringence Effects," *Optical Engineering* 41(12):3183-3192, Dec. 2002.
- Zilliack, G.G., "Further Developments of the Fringe-Imaging Skin Friction Technique," NASA, Ames Research Center, Dec. 1996, 39 pages.

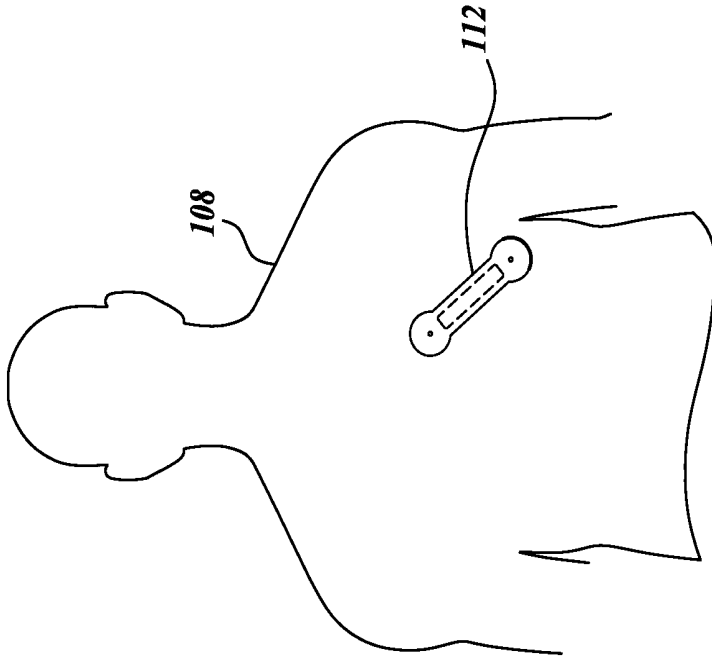

Fig. 1B.

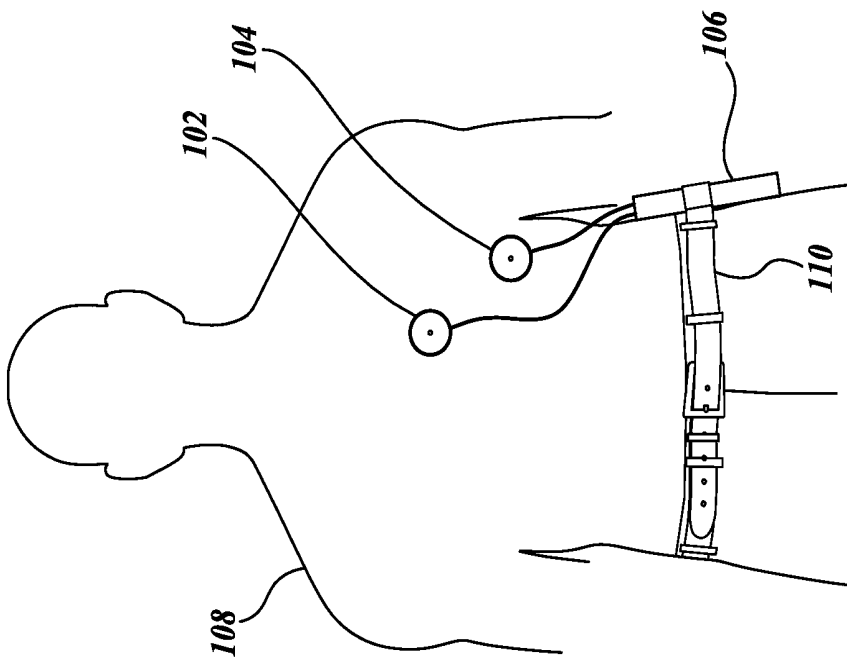

Fig. 1A.

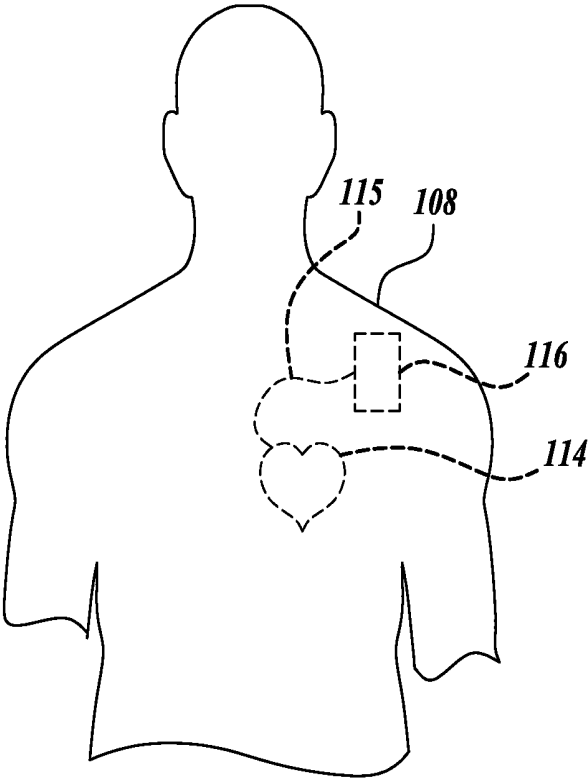

Fig. 1C.

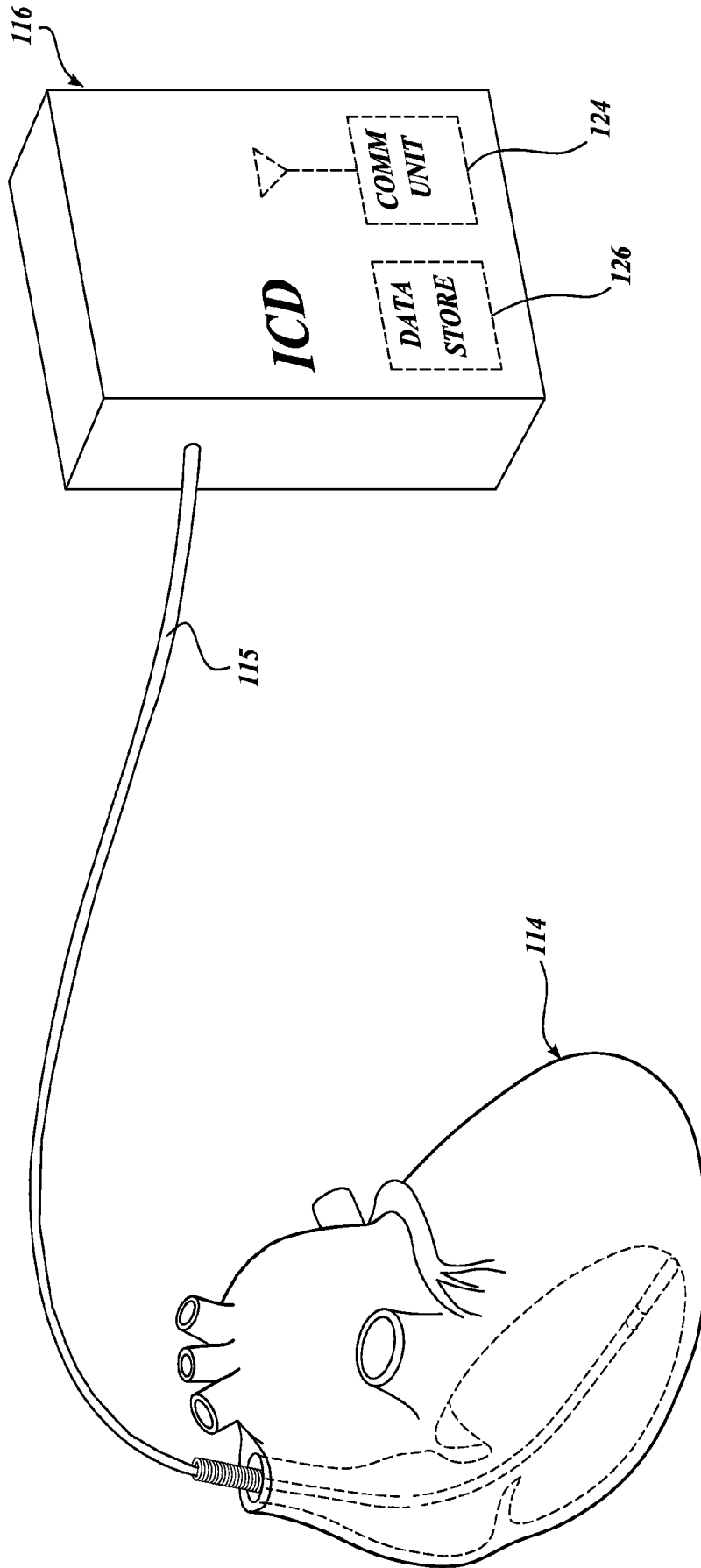

Fig. 1D.

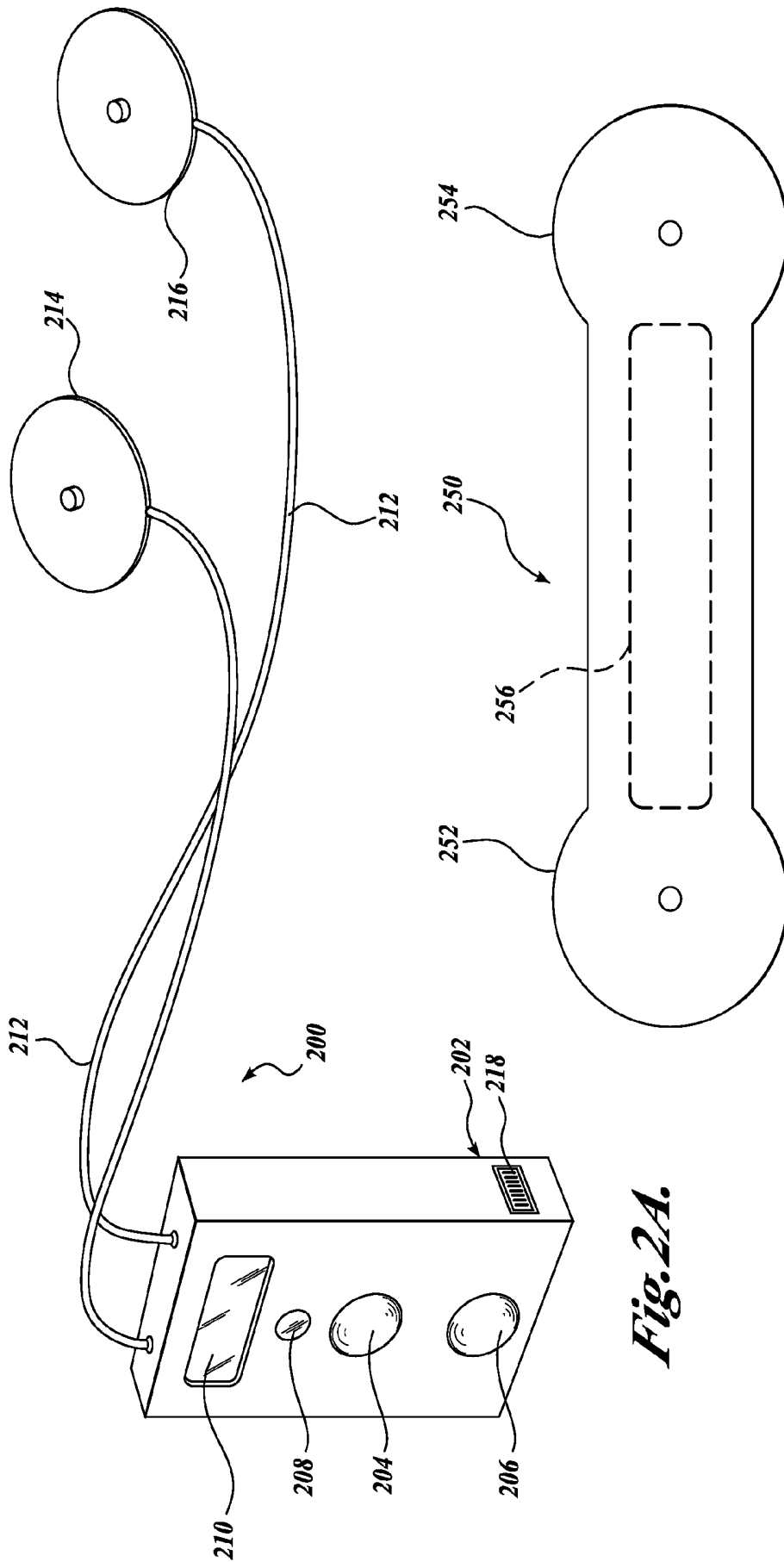

Fig. 2A.

Fig. 2B.

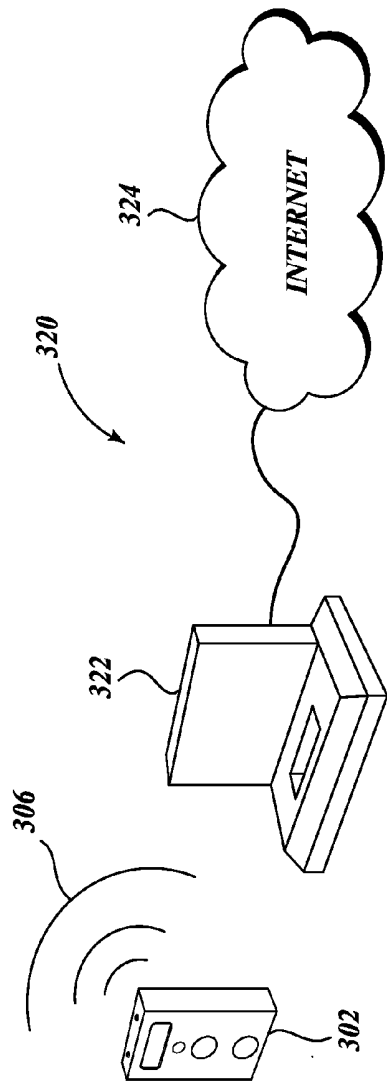

Fig. 3A.

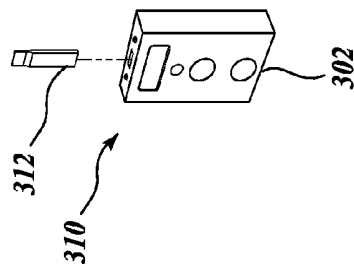

Fig. 3B.

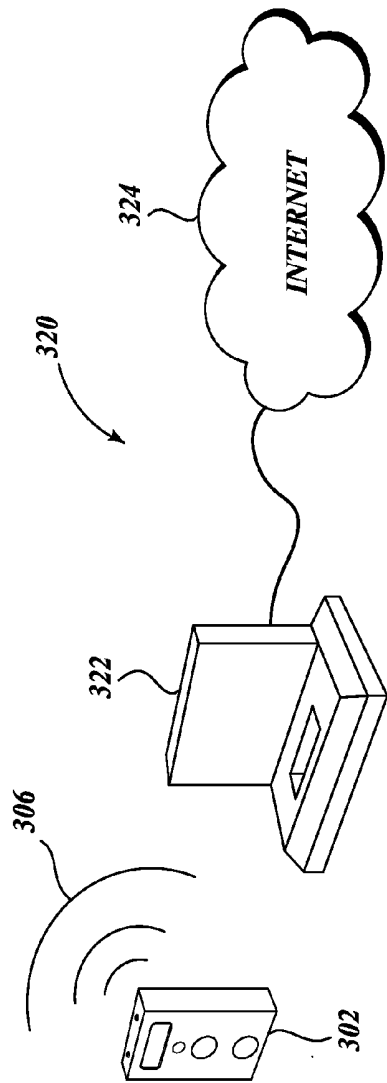

Fig. 3C.

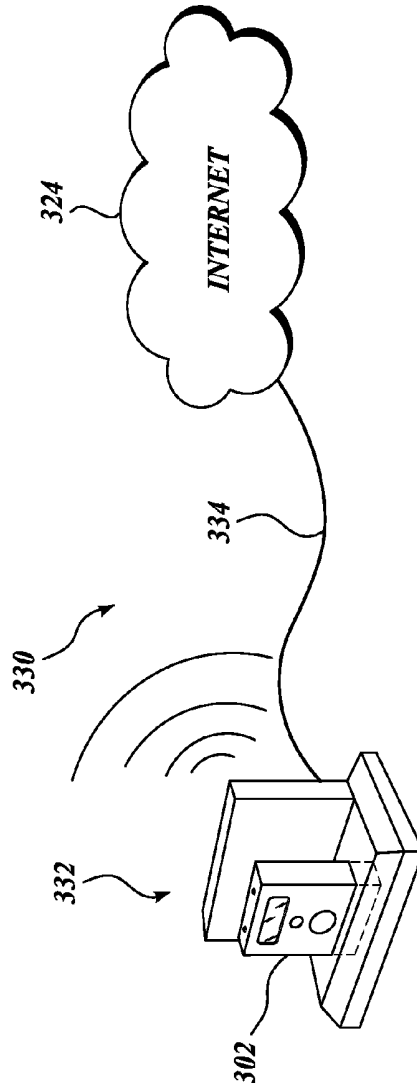

Fig. 3D.

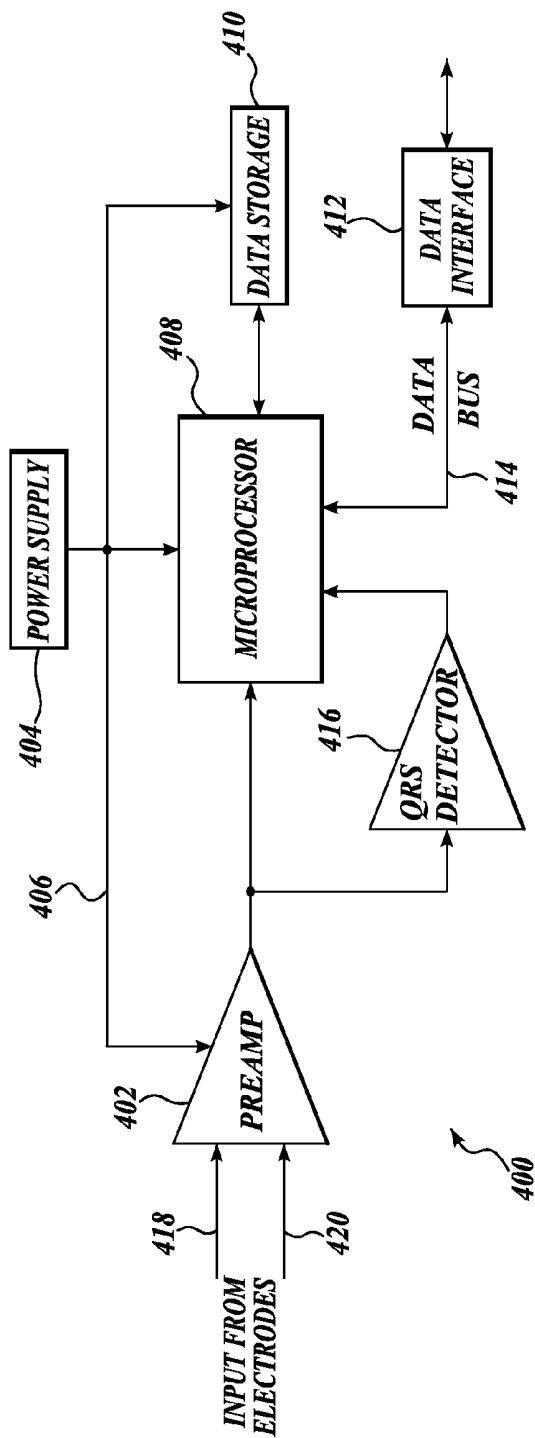

Fig. 4A.

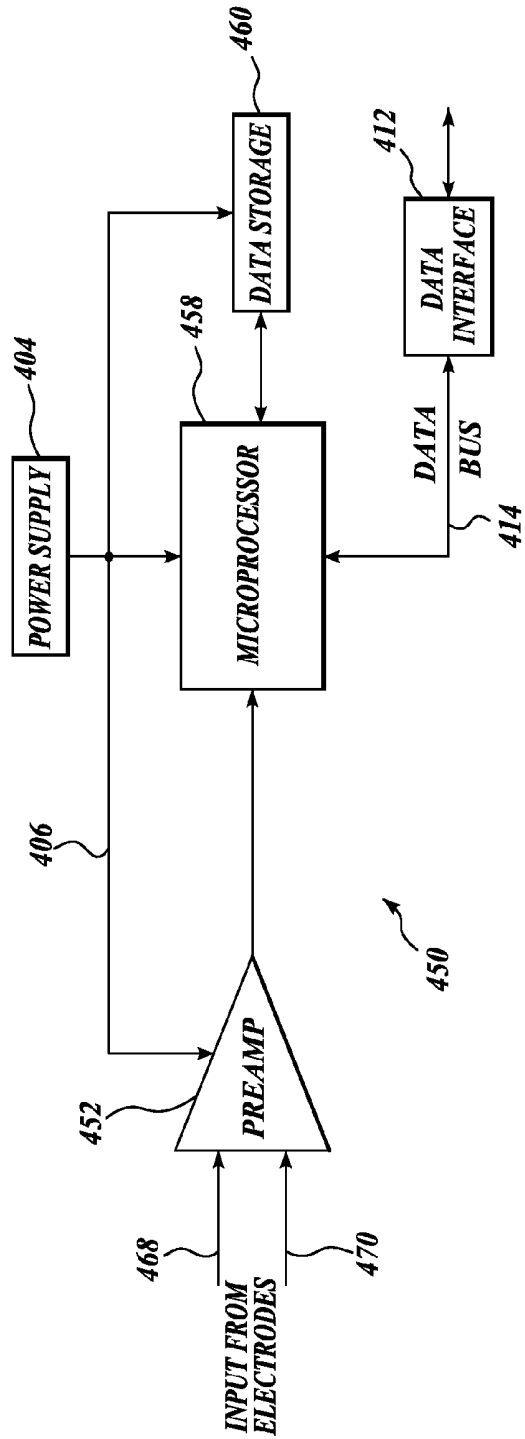

Fig. 4B.

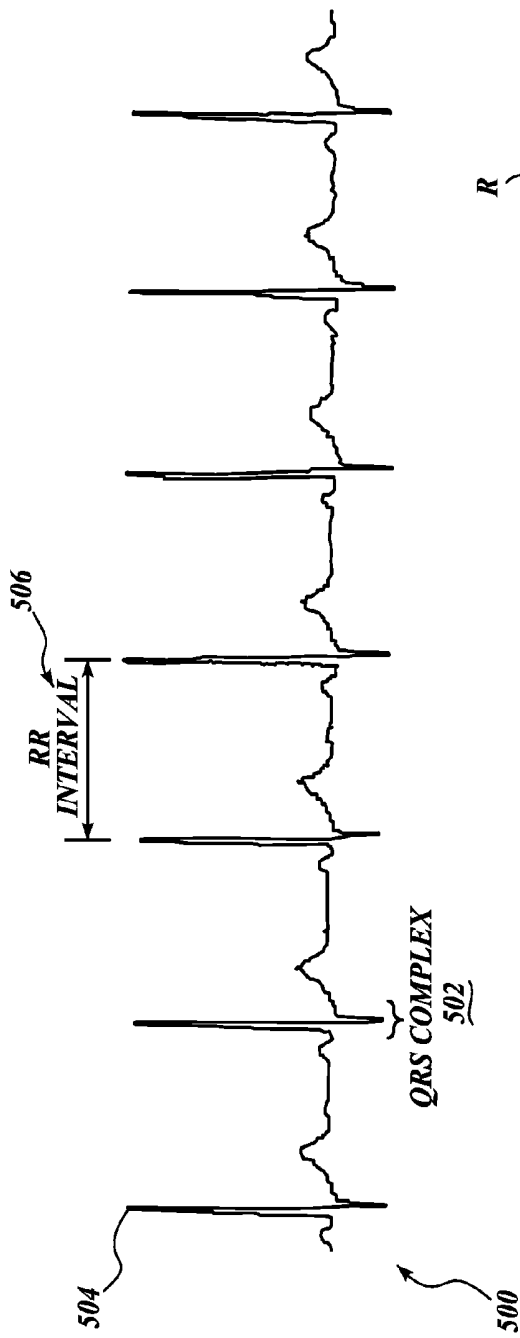

Fig. 5.

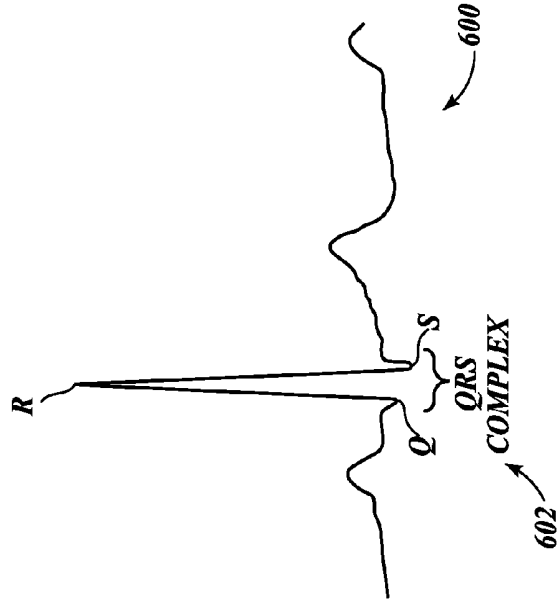

Fig. 6.

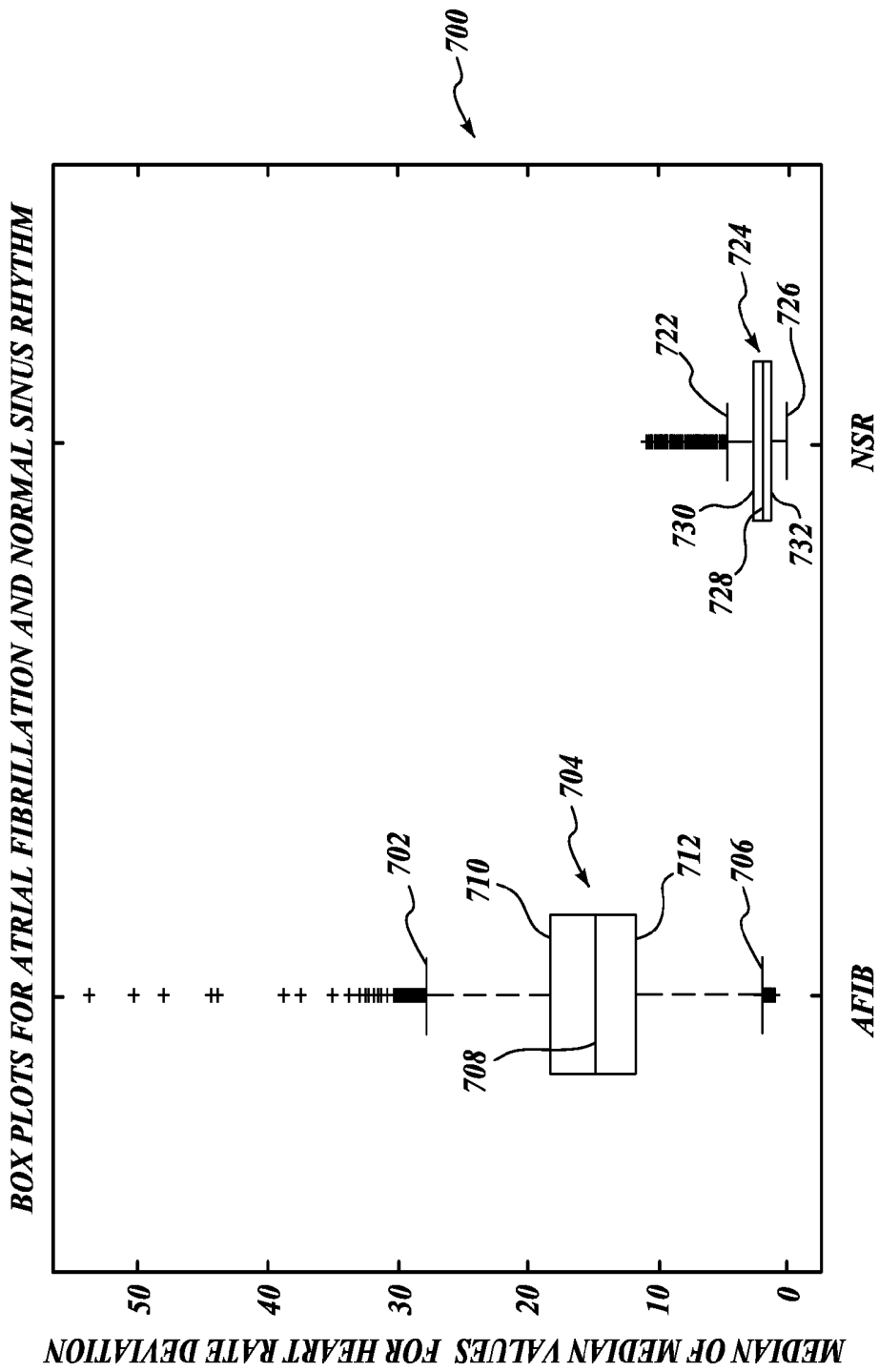

Fig. 7.

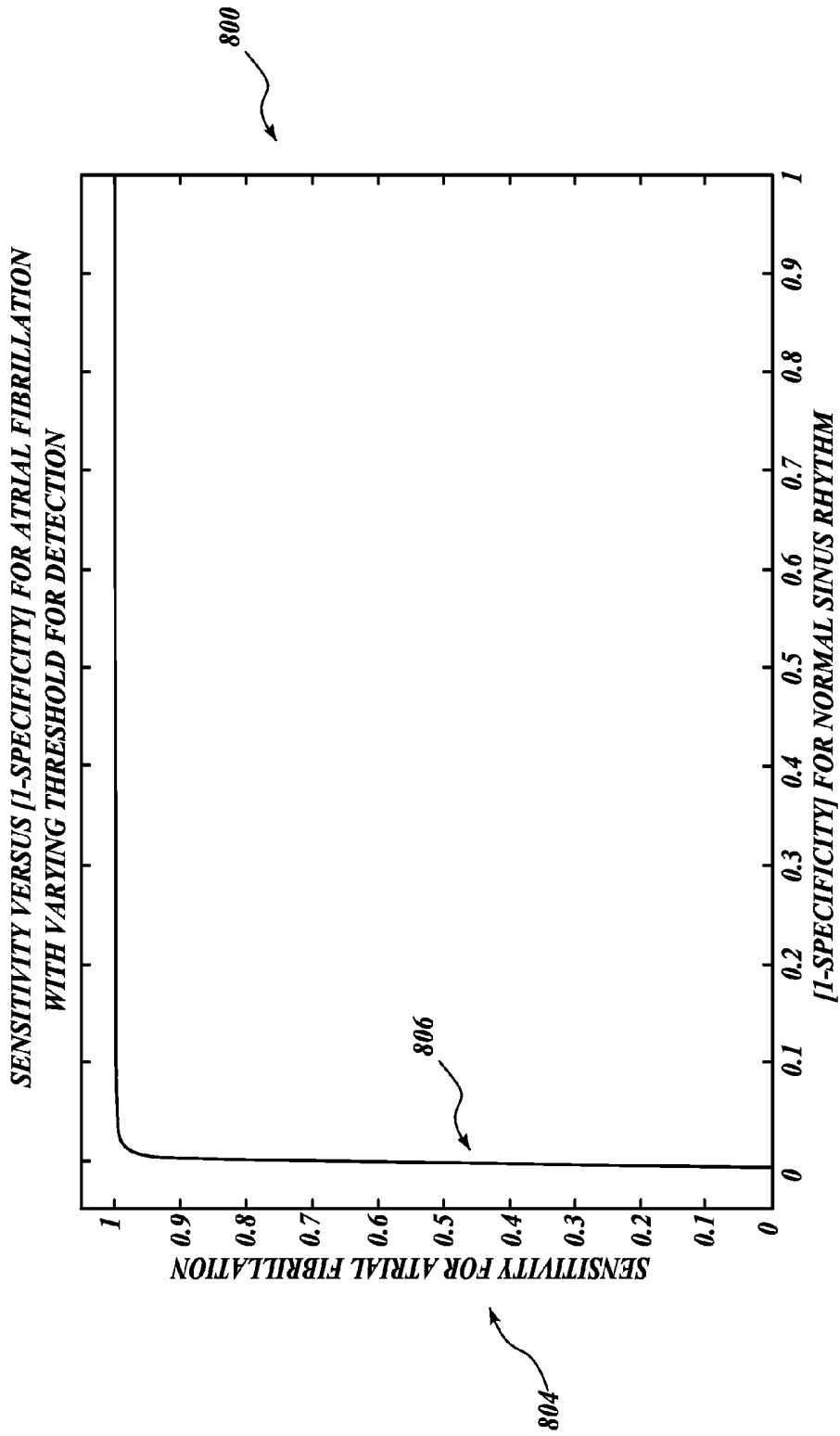

Fig. 8.

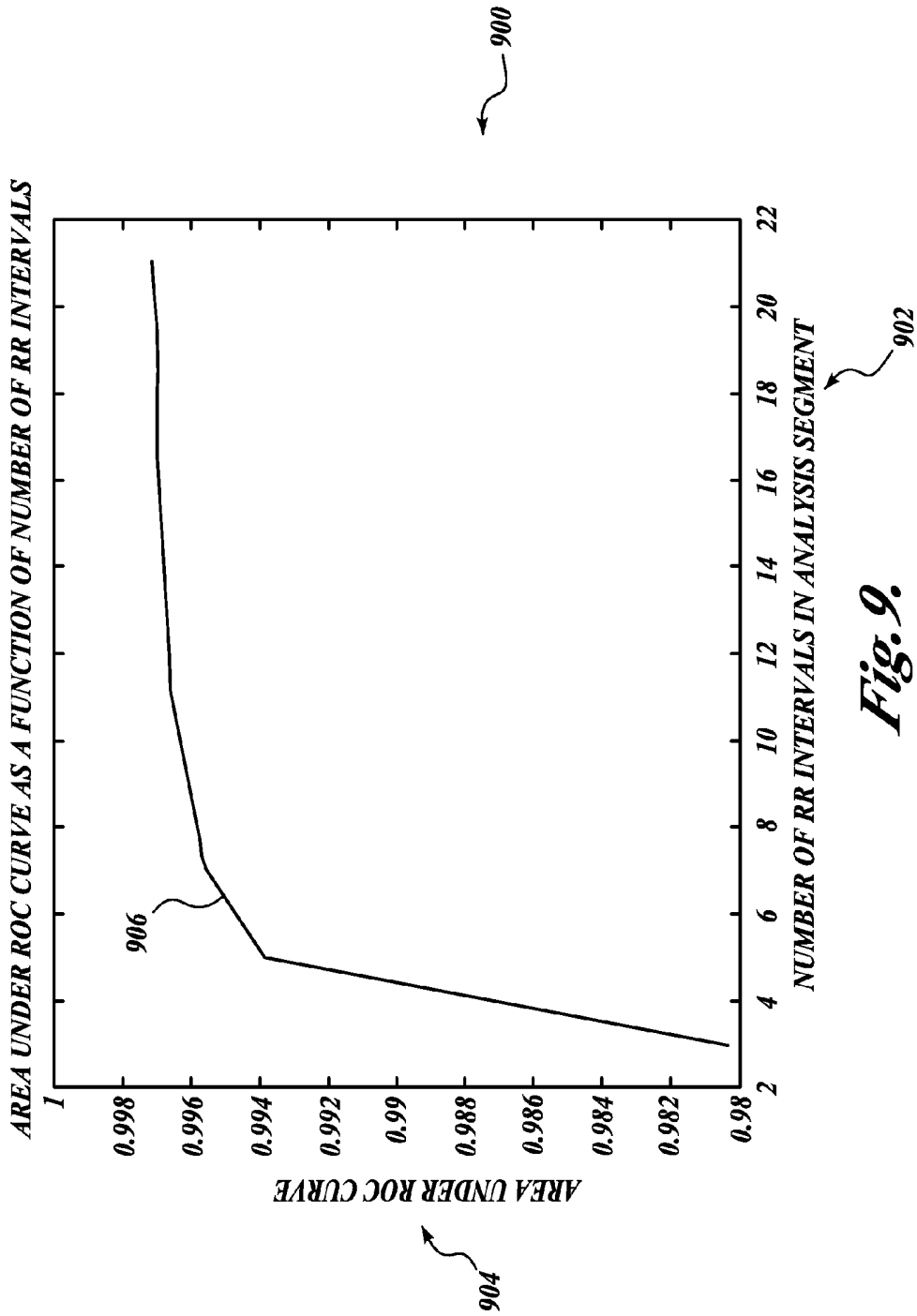

Fig. 9.

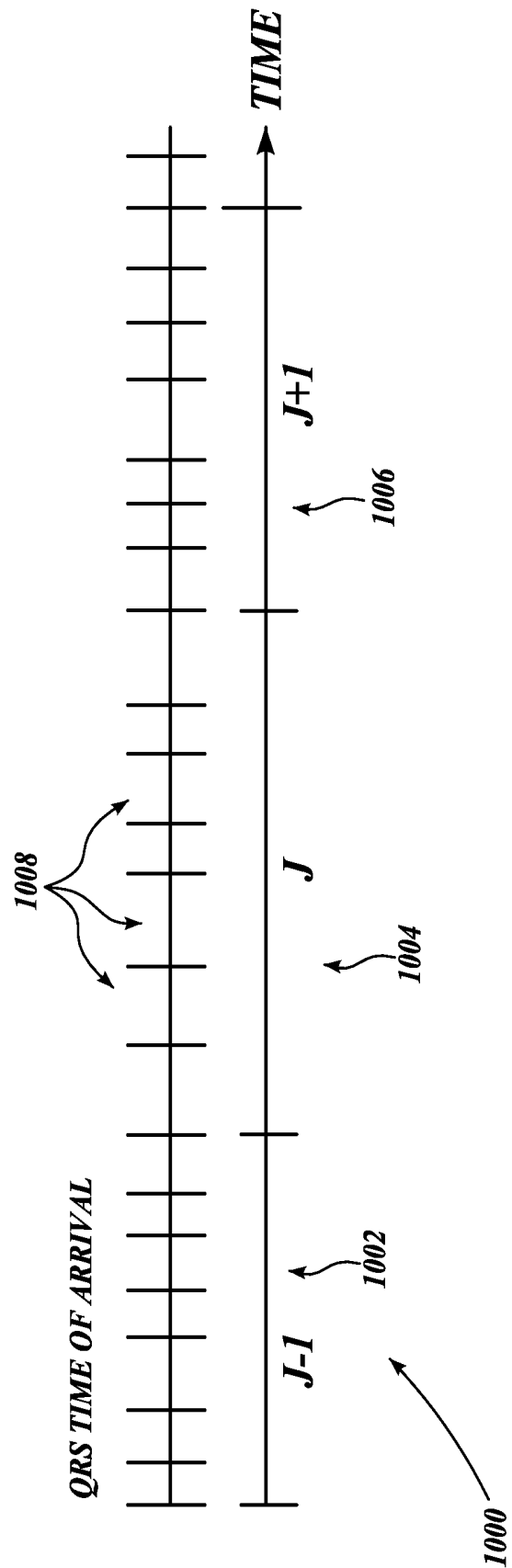

Fig. 10.

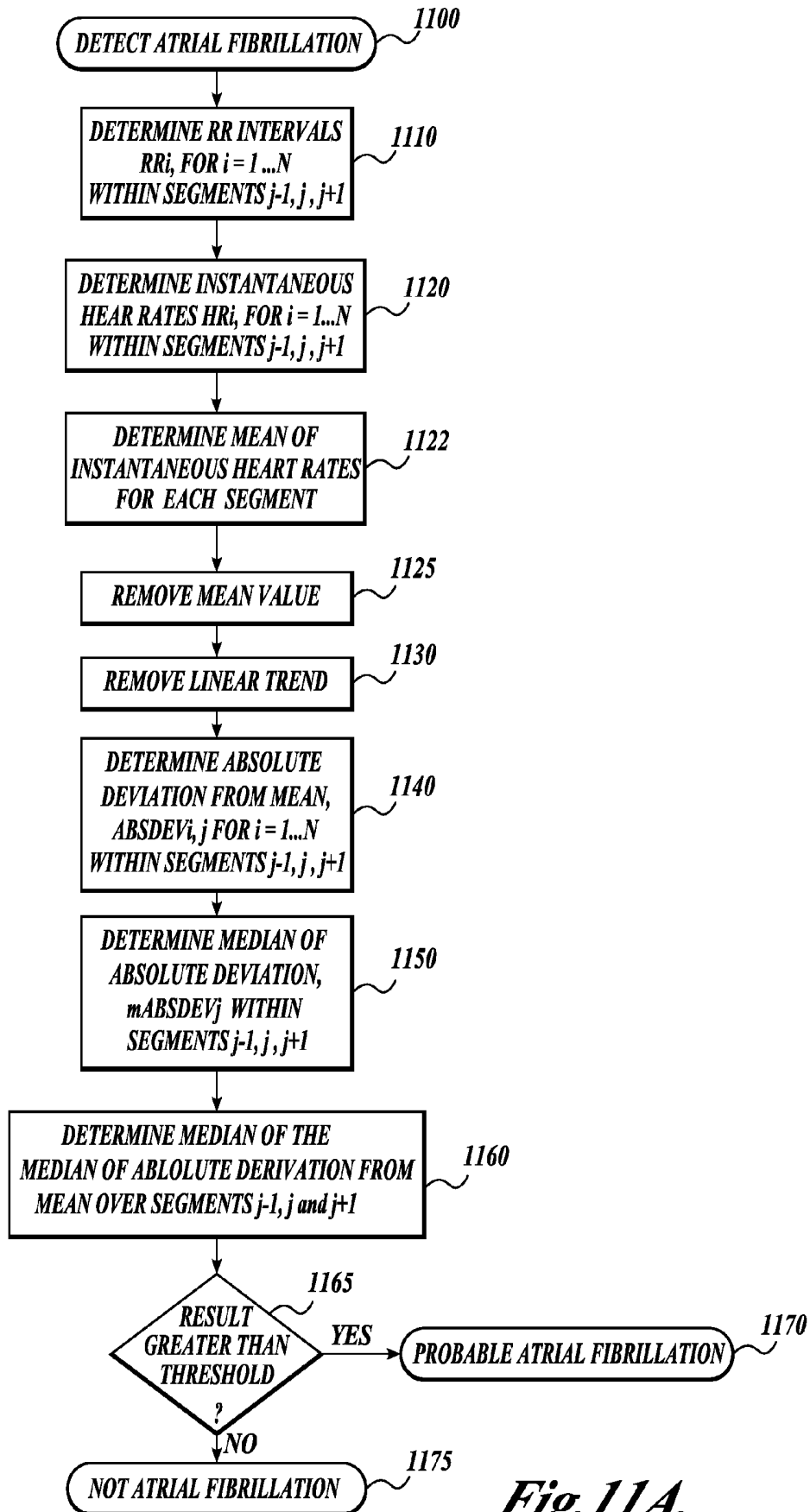

Fig. 11A.

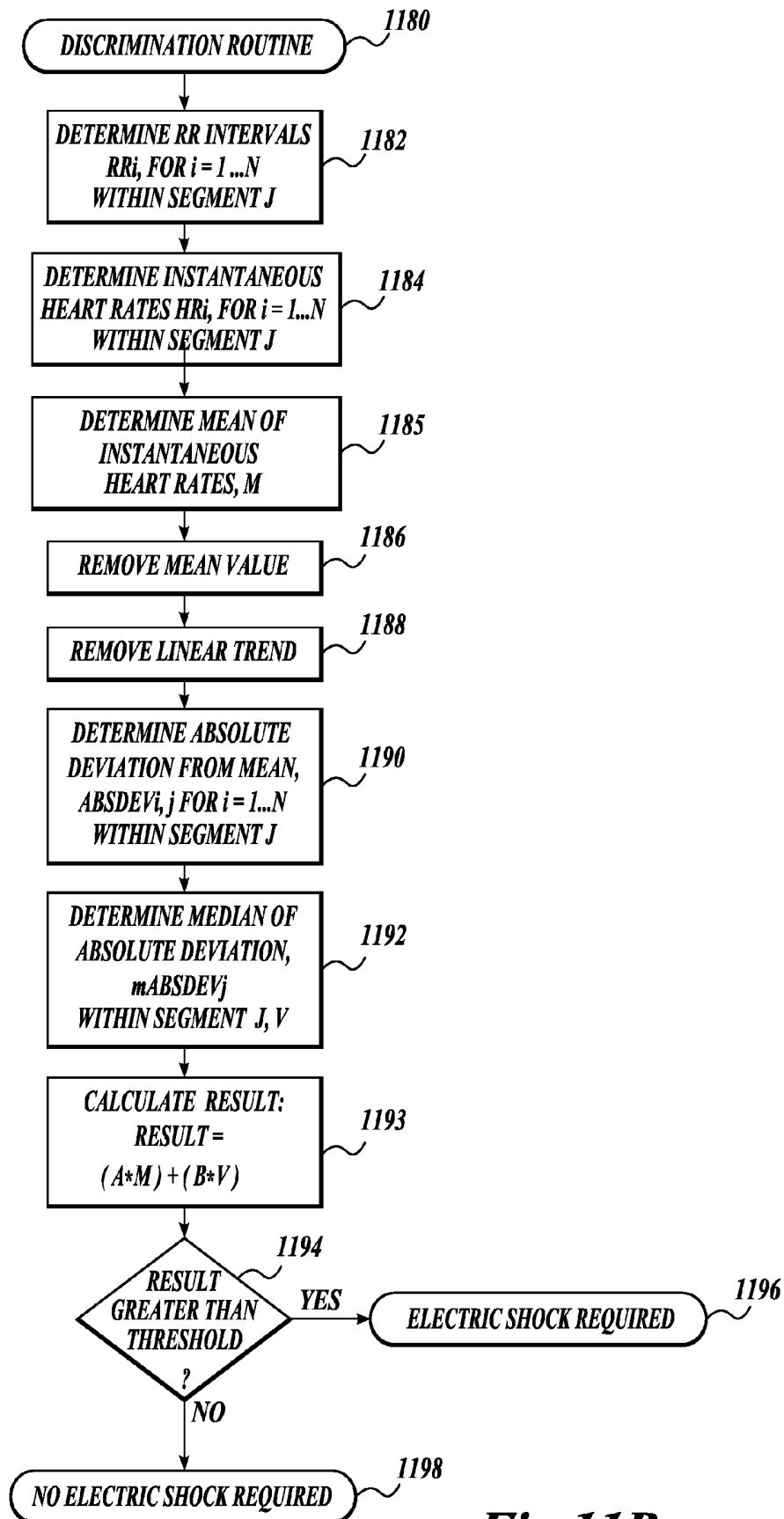

Fig. 11B.

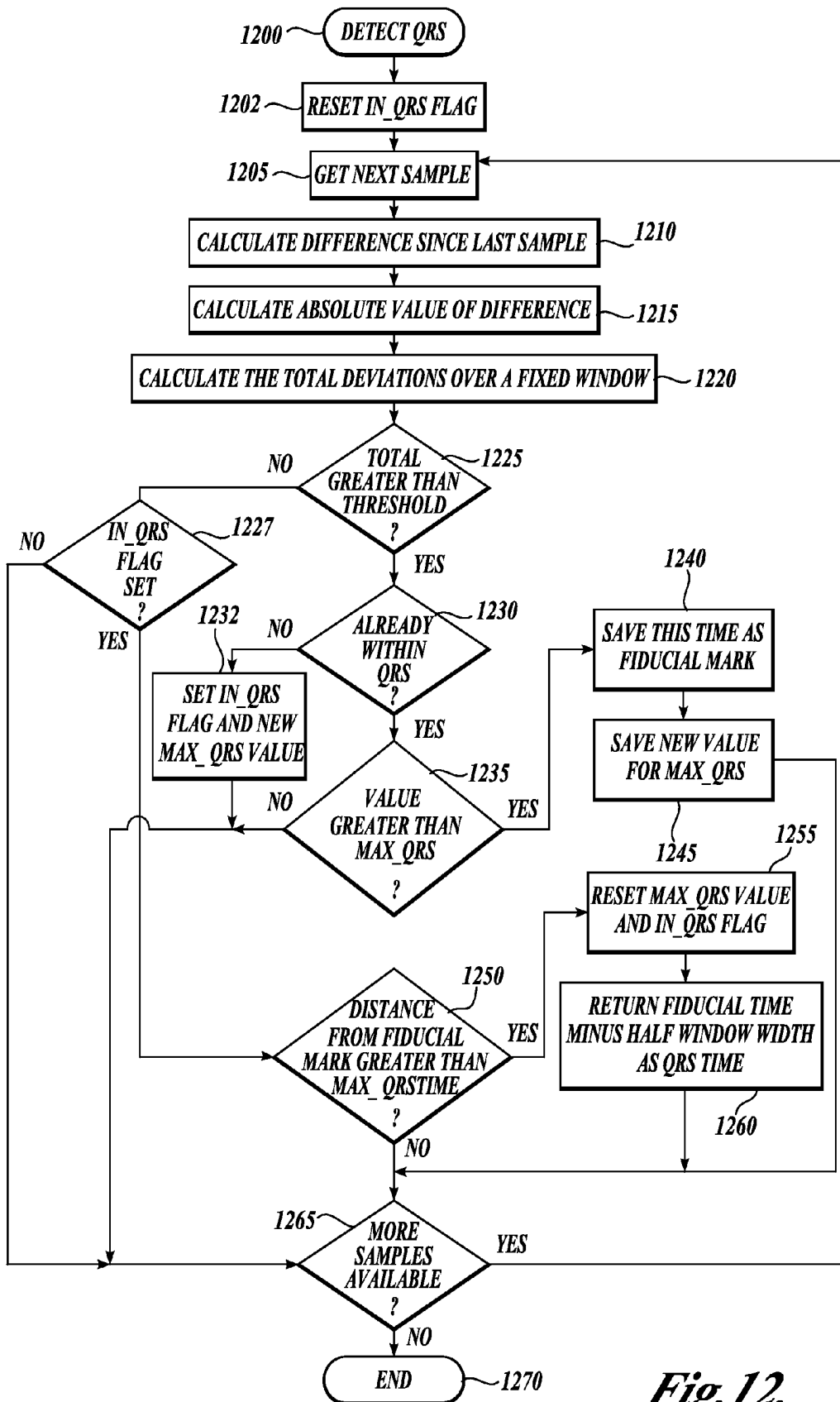

Fig. 12.

LONG-TERM MONITORING FOR DISCRIMINATION OF DIFFERENT HEART RHYTHMS

CROSS-REFERENCES TO RELATED APPLICATIONS

This application is a continuation of co-pending application Ser. No. 13/670,246, filed Nov. 6, 2012 (now U.S. Pat. No. 8,798,727), which is a continuation of application Ser. No. 12/125,859, filed May 22, 2008 (now U.S. Pat. No. 8,326,407), which is a continuation-in-part of application Ser. No. 11/253,375, filed Oct. 19, 2005 (now U.S. Pat. No. 7,630,756), which claims the benefit of Provisional Application No. 60/620,598, filed Oct. 19, 2004, the entire disclosures of which are hereby incorporated by reference herein.

BACKGROUND

Various groups of heart rhythm disorders are known, some of which are life-threatening and require immediate attention and treatment, such as ventricular fibrillation and ventricular tachycardia, and others which may require treatment but not as immediately, such as atrial fibrillation. Atrial fibrillation (“AF”), for example, is a common rhythm disturbance of the heart associated with increased risk of stroke and death. Ventricular fibrillation is much less common, but it always results in death within minutes, unless it is converted to a less dangerous rhythm. Ventricular tachycardia is also not common, but may result in death if not treated promptly.

Currently, AF is diagnosed by symptoms or is discovered incidentally. Available evidence indicates that a significant portion of patients with AF do not have symptoms, and consequently may not be discovered during routine medical examinations unless they happen to be in atrial fibrillation at the time of the examination. However, AF may be diagnosed using medical equipment, such as rhythm monitors. Monitoring techniques used by available rhythm monitors include monitoring the heart rhythm for a short period of time or intermittently. Unfortunately, these monitoring techniques have low sensitivity for the detection of AF if it is not present during the short monitoring period. Conventional rhythm monitors have limited storage capacity for storing monitoring data used to determine the extent of AF.

AF is the most common disturbance of the heart rhythm requiring treatment. Epidemiologic data estimates that 2.2 million individuals suffer from AF in the United States. The incidence of AF increases with age. The prevalence of AF is approximately 2-3% in patients older than 40 years of age and 6% in those individuals over 65 years and 9% in individuals over 80 years old. Feinberg, W. M., et al., *Prevalence, Age Distribution, and Gender of Patients With Atrial Fibrillation*, 155 Arch. Intern. Med. 469 (1995). As the U.S. population ages, AF will become more prevalent. It is estimated that over 5 million Americans will suffer from AF by the year 2050. Go, A. S., et al., *Prevalence of Diagnosed Atrial Fibrillation in Adults: National Implications for Rhythm Management and Stroke Prevention: the Anticoagulation and Risk Factors in Atrial Fibrillation (ATRIA) Study*, 285 JAMA, 2370 (2001). AF is associated with a doubling of mortality rate of people afflicted with AF compared to people who are not, and an increased risk of stroke of about 5% per year. Fuster, V., et al., *ACC/AHA/ESC Guidelines for the Management of Patients With Atrial Fibrillation*, 22 Eur. Heart J. 1852 (October 2001).

AF can be either symptomatic or asymptomatic, and can be paroxysmal or persistent. Symptomatic AF is a medical con-

dition wherein symptoms are readily detectable by experts in the field. AF is usually diagnosed when a patient reveals associated symptoms or complications, such as congestive heart failure or stroke. AF may also be diagnosed incidentally during a routine medical evaluation. Asymptomatic AF is a medical condition wherein symptoms normally associated with AF are either absent or are not readily detectable by experts in the field.

Paroxysmal AF comprises occasional episodes of the AF condition in the patient. Persistent AF is a continuous existence of the condition. Patients with asymptomatic paroxysmal AF may be exposed to the risk of devastating consequences such as stroke, congestive heart failure, or tachycardia mediated cardiomyopathy, for years before a definitive diagnosis of AF can be made.

Current standard techniques and devices for detecting AF include a resting electrocardiogram, which records about 15 seconds of cardiac activity, a Holter monitor, which records 24-48 hours of cardiac activity during routine daily activities, and an event monitor, which only records cardiac activity when the patient activates the monitor because the patient has detected symptoms associated with AF. These diagnostic methods and tools have significant limitations in diagnosing AF and assessing the efficacy of treatment because of the limited recording time windows of these methods and tools. The prevalence of asymptomatic AF is difficult to assess, but is clearly underrepresented in the figures quoted above.

Pharmacologic treatment of AF may convert patients with symptomatic AF into patients with asymptomatic AF. In a retrospective study of four studies comparing Azimilide drug to placebo where, in the absence of symptoms, routine transtelephonic electrocardiograms were recorded for 30 seconds every two weeks, asymptomatic AF was present in 17% of the patients. Page, R. L., et al., *Asymptomatic or “Silent” Atrial Fibrillation: Frequency in Untreated Patients and Patients Receiving Azimilide*, 107 Circulation 1141 (2003).

In another study of 110 patients with permanently implanted pacemakers who had a history of AF, the condition was diagnosed in 46% of the patients using electrocardiogram (“EKG”) recording and in 88% of the patients using stored electrograms recorded by the implanted pacemaker. Israel, C. W., et al., *Long-Term Risk of Recurrent Atrial Fibrillation as Documented by an Implantable Monitoring Device*, 43 J. Am. Coll. Cardiol. 47 (2004).

Review of data stored in implanted devices, such as pacemakers, revealed that 38% of AF recurrences lasting greater than 48 hours were completely asymptomatic. Finally, using data obtained from ambulatory monitors used on patients with paroxysmal AF over a 24-hour period, studies show a high frequency of occurrence of asymptomatic AF among patients treated with propranolol or propafenone drugs. Wolk, R., et al., *The Incidence of Asymptomatic Paroxysmal Atrial Fibrillation in Patients Treated With Propranolol or Propafenone*, 54 Int. J. Cardiol. 207 (1996). In the above-mentioned study, 22% of the patients on propranolol and 27% of the patients on propafenone were diagnosed with AF without symptoms.

There is also evidence that previously undetected AF is associated with stroke. About 4% of patients with stroke admitted to a medical facility also had newly diagnosed AF which was thought to be a precipitating cause of the stroke. Lin, H. J., et al., *Newly Diagnosed Atrial Fibrillation and Acute Stroke, The Framingham Study*, 26 Stroke 1527 (1995).

Under-detection and under-recognition of AF in patients may have significant clinical consequences. A first consequence includes clinical exposure of patients to a significant

risk of cardioembolic stroke before detection of the arrhythmia and initiation of appropriate stroke prevention measures.

A second consequence includes difficulty of assessment of the efficacy of rhythm control intervention. Physicians caring for such patients may erroneously conclude that AF is no longer present and inappropriately discontinue anticoagulation treatments which may lead to a devastating cardioembolic stroke. Consequently, once diagnosed with AF, many patients may be committed to life-long anticoagulation by the physician to avoid the latter issues.

A third consequence includes overestimation of successful maintenance of sinus rhythm. Clinical studies evaluating the efficacy of various rhythm control strategies may overestimate the successful maintenance of sinus rhythm as many of these studies report symptomatic AF as an endpoint. An accurate long term monitoring device would enhance the diagnostic yield of capturing asymptomatic paroxysmal atrial fibrillation, potentially allowing the safe withdrawal of anticoagulation treatments in patients treated successfully with anti-arrhythmic agents, identifying the patients at risk who are currently not diagnosed as having AF, and providing a more precise measure of the efficacy of pharmacologic and non-pharmacologic rhythm control strategies.

Detection of AF, automatically or manually, based on statistical data, requires the use of thresholds defined with respect to sensitivity and specificity. The thresholds used define the point beyond which a set of data indicate existence of AF. Sensitivity and specificity are defined as follows. In a dichotomous experiment, a given event, e , falls into one of two sets, such as a set of positive events, P , and a set of negative events, N . The set P includes events p and the set N includes events n .

A detection test may be performed to determine that the given event e belongs to the set P or to the set N in a dichotomous experiment. Sensitivity is a measure of how well the detection test can correctly identify the given event e of the set P as belonging to the set P . Such events e that are correctly identified as belonging to the set P are known as true positives ("TP"). Such events e that are misidentified as belonging to the set N are known as false negatives ("FN").

Sensitivity is defined as the ratio of the number of true positive events detected correctly by the test to the total number of actual positive events p . The total number of actual positive events is equal to the sum of the TP and FN. That is, $\text{sensitivity} = \text{TP}/(\text{TP} + \text{FN})$. A low sensitivity detection test will misidentify more positive events as belonging to the set N than a high sensitivity detection test.

Specificity is the dual of sensitivity and is a measure of how well the detection test can correctly identify the given event e of the set N as belonging to the set N . Such events e that are correctly identified as belonging to the set N are known as true negatives ("TN"). Such events e that are misidentified as belonging to the set P are known as false positives ("FP"). Specificity is defined as the ratio of the number of true negative events detected correctly by the test to the total number of actual negative events n . The total number of actual negative events is equal to the sum of the TN and FP. That is, $\text{specificity} = \text{TN}/(\text{TN} + \text{FP})$. A low specificity detection test will misidentify more negative events as belonging to the set P than a high specificity detection test.

A number of techniques have been used for the automated detection of AF from digitized electrocardiograms. One of the techniques used includes the use of intracardiac recordings obtained from implanted devices showing a sensitivity of close to 100% and a specificity of greater than 99%. Swerd-

low, C. D., et al., *Detection of Atrial Fibrillation and Flutter by a Dual-Chamber Implantable Cardioverter-Defibrillator*, 101 *Circulation* 878 (2000).

A method for analysis of the surface monitor leads using a wavelet transform achieved a sensitivity of 96% and specificity of 93% in recordings from patients with paroxysmal atrial fibrillation. Duverney, D. et al., *High Accuracy of Automatic Detection of Atrial Fibrillation Using Wavelet Transform of Heart Rate Intervals*, 25(4) *Pacing and Clinical Electrophysiology* 457 (2002). At least one group has proposed using wavelets for implantable/wearable monitoring devices. Ang, N. H., *Real-Time Electrocardiogram (ECG) Signal Processing for Atrial Fibrillation (AF) Detection*, Modeling Seminar-Archive (2003).

A prominent characteristic of AF is heart rate variability. There have been attempts to use the variability of heart inter-beat ("RR") intervals directly to identify AF, resulting in a sensitivity of 94% and specificity of 97% using a threshold based on the Kolmogorov-Smirnov test. Tateno, K. and Glass, L., *Automatic Detection of Atrial Fibrillation Using the Coefficient of Variation and Density Histograms of RR and ΔRR Intervals*, 39(6) *Med. Biol. Eng. Comput.* 664 (2001). The Kolmogorov-Smirnov test (Chakravart, Laha, and Roy, 1967) is used to decide if a statistical sample belongs to a population with a specific probability distribution.

Long-term monitoring of cardiac activity is desirable for timely detection of AF, but the storage requirements can be prohibitive. To digitize a single channel EKG at 100 samples per second and 10-bit resolution, which constitute near minimum requirements for a high quality signal, for 90 days of continuous recording requires 927 megabytes of storage. Although providing this amount of storage is possible, it is also costly. Advances in electronics allow the design of portable devices that can pre-process and classify the signals to avoid storage of normal rhythms and save the storage capacity for recording of abnormal rhythms indicating existence of atrial fibrillation.

Selective storage of signals that potentially indicate AF as opposed to normal heart rhythm effectively increases the storage capacity and prolongs the recording period. At least two such devices exist in the market. One such device has been developed by Instromedix (San Diego, Calif.), and is available in two versions. Each version can monitor the heart rhythm for up to 30 days, capturing a total of 10 minutes of potentially abnormal EKG. The device weighs about 4 ounces. The other device is based on satellite telephone technology, and transmits the suspect rhythms to a monitoring facility. For such a device, accurate algorithms are also important, since high sensitivity will result in a high probability of detection, and high specificity will avoid transmission and review of normal rhythms.

Recently, another device was announced with a detection rate of 90% and a monitoring storage capacity equivalent to 60 minutes of recorded data. A device for home use which does "momentary" analysis of the electrocardiogram as the patient grasps handles on the device daily is disclosed in U.S. Pat. No. 6,701,183, issued to Baker et al. on Mar. 2, 2004, entitled *Long Term Atrial Fibrillation Monitor*.

A device is desired for the long-term monitoring of AF that is inexpensive, non-invasive, highly accurate, and convenient for the patient. These requirements at least indicate that the monitoring device should be light and small. As such, a device is desired with low power requirements and with a significant amount of storage. The storage capacity may possibly be extended by using an algorithm for the elimination of EKG data that indicate very low-probability of AF. This algorithm should be small in size and simple in operation to reduce

processing power needs and electrical power requirements. The existing algorithms based on wavelets appear to be overly complex for this type of application, requiring a significant amount of processing and electrical power as well as storage capacity.

As should be apparent to one skilled in the art, there are situations where the accurate detection of AF would be desirable in an implantable device as well. There are implantable devices that are intended solely for diagnosis of rhythm disturbances, and devices implanted for therapy which have additional diagnostic functions. These devices would also benefit from accurate, low computational complexity detection of AF. It should also be apparent that devices intended to treat AF, either by electric shocks delivered to the heart, or medications administered to control atrial fibrillation, such as propafenone, amiodarone or beta-blockers, or to convert AF, such as ibutilide, would benefit from accurate, low-computational cost complexity detection of AF.

For response to and treatment of ventricular tachycardia and ventricular fibrillation in real-time, often an implantable cardiac defibrillator ("ICD") is surgically implanted in the patient and coupled with the heart to monitor heart rhythm and detect these life-threatening rhythm disturbances. The ICD typically includes logic components implemented in software/firmware and/or hardware for detecting arrhythmia. Once life-threatening arrhythmia is detected, the ICD logic component may, based on a discrimination algorithm, determine that some action, such as administering an electric shock (defibrillation), must be taken to treat the arrhythmia.

However, this determination can be erroneous. In some ICDs such as inappropriate shocks can occur in 15% of all patients within a 46-month follow-up. Alter, P., et al., *Complications of Implantable Cardioverter Defibrillator Therapy in 440 Consecutive Patients*, 28(9) *Pacing and Clinical Electrophysiology*, 926 (2005). Certain sub-populations may have a higher rate of inappropriate shocks, for example, this can occur in as many as 38% of younger patients. Costa, R., et al., *Incidence of Shock and Quality of Life in Young Patients with Implantable Cardioverter-Defibrillator*, 88(3) *Arq. Bras. Cardiol.* 258 (2007). A common cause of inappropriate shock in these patients is AF, although virtually any supraventricular tachycardia can cause an inappropriate shock.

When not needed, an electric shock causes extreme discomfort and/or pain to the patient and may be potentially dangerous. Accordingly, a more accurate discrimination algorithm is needed to discriminate between cases where an electric shock is needed and cases where an electric shock is not needed. One approach that has been used is based on the heart rate, or beat-to-beat intervals, as in a recent study by Mletzko, Mletzko, R., et al., *Enhanced Specificity of a Dual Chamber ICD Arrhythmia Detection Algorithm by Rate Stability Criteria*, 27(8) *Pacing and Clinical Electrophysiology* 1113 (2004).

Another approach uses the morphology of the electrocardiographic complexes to help discriminate, with a representative recent method being the use of wavelet-transforms. Klein, G. J., et al., *Improving SVT Discrimination in Single-Chamber ICDs: A New Electrogram Morphology-Based Algorithm*, 17(12) *J. Cardiovascular Electrophysiology* 1310 (2006). In spite of these methods, inappropriate shocks continue to be a problem in such devices.

An additional constraint is that, since the devices are battery powered and implanted, power consumption is a major consideration. Cebrián, A., et al., *Implantable Cardioverter Defibrillator Algorithms: Status Review in Terms of Computational Cost*, 52(1) *Biomed. Tech. (Berl)* 25 (2007).

The power consumption is related to the complexity of the algorithm, and the hardware required. The ideal algorithm would not require specialized hardware, and would have a low computational complexity, so that power consumption would be low.

SUMMARY

This summary is provided to introduce a selection of concepts in a simplified form that are further described below in the Detailed Description. This summary is not intended to identify key features of the claimed subject matter, nor is it intended to be used as an aid in determining the scope of the claimed subject matter.

A method and a system for long-term monitoring and detection of an arrhythmia, discrimination between different types of arrhythmia, and delivering an electric shock or other therapy upon detection of an appropriate type of arrhythmia, the method comprising determining a number of heart beat intervals; determining an instantaneous heart rate for each of the heart beat intervals; removing the trend of the instantaneous heart rates; determining the variability of the de-trended instantaneous heart rates compared to a mean of the number of instantaneous heart rates; determining a non-linear value that represents the variability of the instantaneous heart rates; using a linear combination of the mean heart rate and the non-linear value to calculate a result; and using the result to discriminate between different types of arrhythmia by comparing the result with a predetermined threshold.

In one illustrative embodiment, an implantable cardiac device for discriminating between different types of arrhythmia is disclosed, the device including a portable power source; electrodes for collecting heart rhythm data from a patient and delivering an electric pulse to the heart upon detection of an appropriate type of arrhythmia; a monitoring circuit coupled to the power source and the electrode, wherein the monitoring circuit analyzes a segment of the collected heart rhythm data to detect an arrhythmia, discriminate between different types of arrhythmia, and deliver an electric pulse to the heart upon a determination that an appropriate type of arrhythmia has been detected; and a memory coupled to the monitoring circuit for storing the heart rhythm data.

A wearable arrhythmia monitoring and detection device is disclosed that includes an elongate substrate with enlarged ends connected by a narrower intermediate section. The enlarged ends incorporate electrodes, and the narrower intermediate portion includes an integrated monitoring system. The monitoring system includes an amplifier that receives electrocardiography signals from the electrodes, a microprocessor that receives amplified signals from the amplifier, a data storage device that stores at least a portion of the data received from the microprocessor, and a power supply. The wearable arrhythmia monitoring and detection device is configured to detect a cardiac arrhythmia, for example atrial fibrillation.

In an embodiment, only electrocardiography data associated with a detected cardiac arrhythmia is stored on the data storage device, and the data may be compressed prior to such storage.

In an embodiment, the monitoring system is configured to perform one or more of the following functions: (i) determine the duration of heart beat intervals from the electrocardiography data for a selected analysis segment comprising a plurality of heart beat intervals; (ii) calculate an instantaneous heart rate for each of the heart beat intervals in the analysis segment; (iii) calculate a test result using the calculated instantaneous heart rates; (iv) compare the test result with a

predetermined threshold to discriminate between different types of cardiac arrhythmia; (v) calculate a mean instantaneous heart rate for the analysis segment; (vi) calculate a deviation from the mean instantaneous heart rate for each heart beat interval in the analysis segment; and (vii) determine a median deviation from the mean instantaneous heart rate in the analysis segment; and use the mean instantaneous heart rate and the median deviation to calculate the test result.

In an embodiment, the monitoring system is configured to calculate a test value as a linear combination of the mean instantaneous heart rate and the median deviation. In an embodiment the monitoring system is configured to use an analysis segment comprising between five and nineteen heart beat intervals.

In an embodiment the integrated monitoring system further includes a wave detection device, such as a QRS detector.

DESCRIPTION OF THE DRAWINGS

The foregoing aspects and many of the attendant advantages of this invention will become more readily appreciated as the same become better understood by reference to the following detailed description, when taken in conjunction with the accompanying drawings, wherein:

FIG. 1A is a pictorial diagram of an illustrative portable atrial fibrillation monitoring and detection device as applied to a patient;

FIG. 1B is a pictorial diagram of another illustrative portable atrial fibrillation monitoring and detection device as applied to a patient;

FIG. 1C is a pictorial diagram of an illustrative implantable monitoring and therapeutic device as applied to a patient;

FIG. 1D is a pictorial diagram of the illustrative implantable therapeutic device illustrated in FIG. 1C;

FIG. 2A is a pictorial diagram of the portable atrial fibrillation monitoring and detection device shown in FIG. 1A;

FIG. 2B is a pictorial diagram of the portable atrial fibrillation monitoring and detection device shown in FIG. 1B;

FIG. 3A is a pictorial diagram of an illustrative operating environment for downloading and uploading data from/to a portable atrial fibrillation monitoring and detection device;

FIG. 3B is a pictorial diagram of another illustrative operating environment for downloading and uploading data from/to a portable atrial fibrillation monitoring and detection device;

FIG. 3C is a pictorial diagram of another illustrative operating environment for downloading and uploading data from/to a portable atrial fibrillation monitoring and detection device;

FIG. 3D is a pictorial diagram of another illustrative operating environment for downloading and uploading data from/to a portable atrial fibrillation monitoring and detection device;

FIG. 4A is a block diagram of an illustrative embodiment of a circuit for monitoring and detection of atrial fibrillation, including a hardware-based QRS signal detector;

FIG. 4B is a block diagram of another illustrative embodiment of a circuit for monitoring and detection of atrial fibrillation;

FIG. 5 is a pictorial diagram of a signal representing a heart rhythm;

FIG. 6 is a pictorial diagram of a signal representing a QRS portion of the heart rhythm;

FIG. 7 shows illustrative box plot graphs of values obtained for atrial fibrillation and for a normal heart rhythm;

FIG. 8 is an illustrative graph of values for Sensitivity versus (1-Specificity);

FIG. 9 is an illustrative graph showing a number of RR intervals versus area under a Receiver Operator Curve ("ROC") for the atrial fibrillation detection algorithm;

FIG. 10 is an illustrative time line of RR intervals, and showing three segments of seven RR intervals;

FIG. 11A is a flow diagram of an illustrative atrial fibrillation detection method in accordance with the present invention;

FIG. 11B is a flow diagram of an illustrative arrhythmia discrimination method in accordance with the present invention; and

FIG. 12 is a flow diagram of an illustrative QRS detection method.

DETAILED DESCRIPTION

A system and a method for detecting cardiac fibrillation and/or for discriminating between classes of arrhythmia is disclosed. In one embodiment, a method and apparatus for long-term monitoring and detection of atrial fibrillation is disclosed. In another embodiment, a modified version of the method and a device are disclosed for discriminating heart signal data to detect and accurately identify and correctly distinguish life-threatening cardiac rhythms that require an electric shock (defibrillation) from other rhythms that do not require a shock. While the system and method are ideally suited for detecting atrial fibrillation, or discrimination of life-threatening rhythms from other rhythms, the system and method may also find use in other environments. Furthermore, while the system and method are described in portable configurations and environments, the system and method may also find use in fixed and static environments. Thus, it is to be understood that the present invention should not be construed as limited in application to the illustrative embodiments described herein, and such illustrative embodiments should not be construed as limiting.

FIG. 1A is a pictorial diagram showing an illustrative operating environment for a portable atrial fibrillation monitoring and detection device ("portable monitoring device"). This illustrative operating environment includes a light-weight, small, portable monitoring device **106** which can be used by a patient **108** daily or continuously for several months. The portable monitoring device **106** may be carried on a belt **110** or other harness. The portable monitoring device **106** shown includes two electrodes **102** and **104** which are attached to the body of the patient **108** for recording cardiac activity. The electrodes **102** and **104** may be fixed to the portable monitoring device **106** or may be detachably connected to the portable monitoring device **106**. The electrodes **102** and **104** may be attached to the body of the patient **108** using various means, including adhesive surfaces, rubber bands, or various kinds of straps and harnesses for holding the electrodes **102** and **104** in place. The electrodes **102** and **104** may also be attached to the body of the patient **108** by being attached to or implanted in the garment of the patient **108**. The portable monitoring device **106** continuously collects data related to cardiac activity from the electrodes **102** and **104**, and stores some or all of the collected data in the internal storage component of the portable monitoring device **106**.

FIG. 1B is a pictorial diagram showing another illustrative operating environment for a portable atrial fibrillation monitoring and detection device wherein the portable monitoring device and attached electrodes are integrated into a unitary monitoring device **112**. In this illustrative operating environment, the integrated monitoring device **112** attaches directly to the body of the patient **108** without the need for the belt **110** or other harness for supporting the device. The integrated

monitoring device **112** is sufficiently thin and light-weight to securely attach to the body of the patient **108**, for example, by means of adhesive surfaces, and to be worn under normal clothes without undue burden. The patient **108** may wear the integrated monitoring device **112** for extended periods of time, removing and re-attaching the integrated monitoring device **112** as necessary for other activities, while noting the times of interruption of the recording operation.

FIG. **1C** is a pictorial diagram showing an implantable monitoring, detection, and intervention device **116** implanted into the patient **108**. In this example embodiment, the device **116** comprises an implantable cardiac defibrillator **116** that is surgically implanted in the patient **108** and coupled with the heart **114** through one or more leads **115** (one shown). The device **116** monitors heart rhythm to detect arrhythmia, discriminates any detected arrhythmia to identify conditions for which intervention is indicated, and administers the desired intervention. For other arrhythmias not requiring immediate intervention, the device may store the information characterizing the event for transmission or download, either immediately or at a later time.

In certain applications when life-threatening heart arrhythmia is detected (e.g., ventricular fibrillation) therapeutic or remedial action or intervention is needed immediately, such as providing appropriate electrical shock to the heart to stabilize or regulate the heart beat. For example, a patient having a life-threatening heart condition may elect to have an ICD implanted in to continuously monitor heart rhythm and intervene when indicated, for example by providing an appropriate electrical shock to the patient's heart. It is also contemplated that an implantable device **116** may alternatively or additionally be operable to dispense suitable medications in response to a detected arrhythmia.

FIG. **1D** shows a pictorial diagram of the single-lead ICD **116** shown in FIG. **1C**, wherein the right ventricular lead **115** extends into the patient's heart **114**. Although a single-lead ICD **116** is shown, it will be apparent that the present invention may be implemented with a multi-lead defibrillator, e.g., a defibrillator having a coronary sinus lead, atrial lead and ventricular lead, as are known in the art. The ICD **116** is surgically implanted in the patient and coupled with the heart **114** to monitor heart rhythm, and to detect and treat arrhythmia when intervention is indicated. In one illustrative embodiment, the ICD **116** includes logic components implemented as embedded software/firmware and/or hardware for detecting arrhythmia, as discussed below. The embedded software may be updateable via wireless communication components **124** incorporated into the ICD **116**.

Similarly, data collected and/or generated by the ICD **116** may be stored in a data store **126**, which is externally readable from the ICD **116** via the wireless communication components **124**, for further analysis. If an arrhythmia is detected, the ICD **116** logic component determines whether a shock must be administered to treat the arrhythmia. The ICD **116** may include other processing components such as a microprocessor/microcontroller for executing software/firmware and controlling other functions of the ICD **116**, a power source, such as a battery, and other hardware and/or software components known in the art and commonly used for these types of devices.

With continued reference to FIG. **1D**, the ICD **116** is coupled with heart **114** via one or more leads and electrodes **115** to detect arrhythmia and administer electric shock when needed. In this embodiment, the right ventricular lead **115** is used to detect the electrical activity of the heart **114** and to deliver therapeutic electric pulses or shock to the heart **114** in response to the detection of a type of arrhythmia for which

electric shock is an appropriate treatment. The determination of the necessity of electric shock and the delivery of such electric shock is performed under the control of the logic components embedded in ICD **116**.

An arrhythmia discrimination method is used to determine if a detected arrhythmia is of a type that requires electric shock treatment. If an electric shock is indicated for the type of arrhythmia detected, then the arrhythmia discrimination algorithm will signal the delivery of an electric shock to the heart **114**. Otherwise, no electric shock is delivered. The currently preferred discrimination method is described more fully below with respect to FIG. **11B**.

FIG. **2A** shows an illustrative embodiment of a portable atrial fibrillation monitoring and detection device **202**. The device configuration **200** shown includes the portable monitoring device **202**, electrodes **214**, **216** and leads **212** coupling the electrodes **214**, **216** to the portable monitoring device **202**. In one illustrative embodiment, the electrodes **214**, **216** are fixed to the portable monitoring device **202**. In another illustrative embodiment, the electrodes **214**, **216** are detachably connected to the portable monitoring device **202**. In one illustrative embodiment, the portable monitoring device **202** comprises at least one display **210**, such as a liquid crystal display ("LCD") panel, to show various information about the data and the status of the device.

In another illustrative embodiment, the portable monitoring device **202** comprises an indicator **208**, such as a light emitting diode ("LED"), to communicate information to the user of the device, for example, by blinking or by using different colors of light. The portable monitoring device **202** further comprises at least one input means **204**, such as a button, to control the settings and the behavior of the portable monitoring device **202**. In another illustrative embodiment, the portable monitoring device **202** comprises two such input means **204** and **206**, one of which may be used by the patient and the other one by a technician during data retrieval or repairs. The portable monitoring device **202** further comprises at least one communication port **218** which is used to download and upload information to and from the portable monitoring device **202**, respectively. The information communicated through port **218** includes data collected by the device, device status, device configuration settings, and device software program updates.

In one illustrative embodiment, the portable monitoring device **202** further comprises internal circuitry (not shown in this figure) that include programmable devices, such as a microcontroller or a microprocessor, and internal software programs that are executed by the microcontrollers or microprocessors to cause the portable monitoring device **202** to collect data and perform other functions as discussed below. In another illustrative embodiment, the portable monitoring device **202** comprises internal circuitry (not shown in this figure) that include devices that operate independent of software for some aspects of the operation of the portable monitoring device **202**, for example counting wave peaks and wave pattern detection. In one illustrative embodiment, the portable monitoring device has a weight of less than one ounce and a volume of less than ten cubic centimeters. It will be appreciated by those skilled in the art that the shape and dimensions of the portable monitoring device **202** shown in FIG. **2A** are for the purpose of illustration and discussion and should not be construed as a limit on the invention.

The portable monitoring device **202** used for detection of arrhythmia and the ICD **116** used for detection, discrimination of different types of arrhythmia, and intervention, may be used as part of one treatment regimen or separately for different medical applications. These devices and the respective

algorithms used in each, as more fully described below with respect to FIGS. 11A and 11B, respectively, share certain features and are different in other important ways in terms of design, application, and results they provide.

In one illustrative embodiment the portable monitoring device 202 and the ICD 116 are integrated as functionally distinct units into one integrated implantable device (not shown in the figures) for detection of and discrimination between different types of arrhythmia. In such an integrated device each of the functional detection and discrimination units performs its own function as described below. In such an integrated implantable device, the functional detection and discrimination components may share common functions and features, such as collection of heart rhythm data, computation of mean and median, and other processing tasks and/or hardware/software components that are common to both functional units. In another illustrative embodiment, the portable monitoring device 202 and the ICD 116 are implemented as separate devices that are used in conjunction with each other or separately, as noted above.

FIG. 2B is a pictorial diagram showing another illustrative embodiment of an integrated portable atrial fibrillation monitoring and detection device 250. In this illustrative embodiment, the integrated monitoring device 250 includes a processing component 256 built into the body of integrated monitoring device 250, and at least two integrated electrodes 252 and 254. In another illustrative embodiment, the integrated monitoring device 250 includes more than two integrated electrodes, taking the form of a star with multiple electrode arms extending from the body of the integrated monitoring device 250. In this illustrative embodiment, the integrated monitoring device 250 is sufficiently thin and light-weight to securely attach to the body of the patient, for example, by means of adhesive surfaces, and to be worn under normal clothes without undue burden. In one illustrative embodiment, the integrated monitoring device 250 further comprises internal circuitry (not shown in this figure) that include programmable devices, such as a microcontroller or a microprocessor, and internal software programs that are executed by the microcontrollers or microprocessors to cause the integrated monitoring device 250 to collect data and perform other functions as discussed below. In another illustrative embodiment, the integrated monitoring device 250 comprises internal circuitry (not shown in this figure) that include devices that operate independent of software for some aspects of the operation of the integrated monitoring device 250, for example counting wave peaks and wave pattern detection. It will be appreciated by those skilled in the art that the shape and dimensions of the integrated monitoring device 250 shown in FIG. 2B are for the purpose of illustration and discussion and should not be construed as a limit on the invention.

FIGS. 3A-3D show several illustrative operating environments for downloading and uploading data from/to a portable atrial fibrillation monitoring and detection device. The portable monitoring device 302 shown in the above-mentioned drawings represents all embodiments of such monitoring device, including the portable monitoring device 202 and the integrated monitoring device 250 discussed above.

FIG. 3A is a pictorial diagram showing an illustrative operating environment 300 for downloading and uploading data from/to a portable atrial fibrillation monitoring and detection device 302. In the operating environment 300, the portable monitoring device 302 communicates with a computer or other data processing equipment at a medical facility or monitoring center (not shown in this figure) where the collected data are used for processing and analysis and maintenance

and setup operations are performed on the portable monitoring device 302. In one illustrative embodiment, the portable monitoring device 302 includes a wireless module which communicates data to a computer or other data processing equipment using electromagnetic waves 306. In one illustrative embodiment, the wireless module of the portable monitoring device 302 includes a Bluetooth wireless interface. In another illustrative embodiment, the wireless module of the portable monitoring device 302 includes a ZigBee® wireless interface. As would be clear to one skilled in the art, there are a number of wireless systems or standards that may alternatively be utilized. In another illustrative embodiment, the portable monitoring device 302 uses a wired interface 304, for example, RS232 serial bus, universal serial bus (“USB”), or Firewire, to communicate data. The data communicated by the portable monitoring device 302 includes data collected by the device, device status, device configuration settings, and other similar information. The communication of data may be from or to the portable monitoring device 302. The portable monitoring device 302 may also receive information from outside, for example, from a technician or a computer, using the wireless module or the wired interface 304. Such information may include configuration settings and software program updates.

FIG. 3B is a pictorial diagram showing another illustrative operating environment 310 for downloading and uploading data from/to a portable atrial fibrillation monitoring and detection device 302. In the operating environment 310, the portable monitoring device 302 communicates with a computer or other data processing equipment at a medical facility or monitoring center (not shown in this figure) where the collected data are used for processing and analysis and maintenance and setup operations are performed on the portable monitoring device 302. In one illustrative embodiment, the portable monitoring device 302 includes a removable memory module 312 which may be removed by a technician at a medical facility or monitoring center for retrieval of data collected by the portable monitoring device 302. In another illustrative embodiment, the memory module 312 is removed by the patient and mailed to the medical facility or monitoring center. Many types of memory devices are available that may be used as embodiments for the memory module 312. For example, in one embodiment, the memory module 312 includes a secure digital (“SD”) memory card. In another illustrative embodiment, the memory module 312 includes a Personal Computer Memory Card International Association (“PCMCIA”) flash type memory card. Yet in another illustrative embodiment, the memory module 312 includes a compact flash card. Still in another illustrative embodiment, the memory module 312 includes a Multimedia card (“MMC”). Still in another illustrative embodiment, the memory module 312 includes a memory stick. The information contained in the memory module 312 generally includes the data collected by the portable monitoring device 302, but may optionally include other information, such as device status, device configuration settings, and device software program updates. New software program updates for the portable monitoring device 302 may be included in the memory module 312.

FIG. 3C is a pictorial diagram showing another illustrative operating environment 320 for downloading and uploading data from/to a portable atrial fibrillation monitoring and detection device 302. In the operating environment 320, the portable monitoring device 302 communicates with a base station 322 at the patient’s home or other remote location away from a medical facility or monitoring center where the collected data is processed and analyzed. The base station 322 may also be used for uploading software program updates,

configuration settings, and other information to the portable monitoring device 302. In one illustrative embodiment, the portable monitoring device 302 includes a wireless module which communicates with base station 322 using electromagnetic waves 306. In one illustrative embodiment, the wireless module of the portable monitoring device 302 includes a Bluetooth wireless interface. In another illustrative embodiment, the wireless module of the portable monitoring device 302 includes a ZigBee® wireless interface. In one illustrative embodiment, the base station 322 is connected to the Internet 324 using various methods of connection, such as a dialup connection, acoustic coupler, wired Ethernet connection, cell phone or wireless Internet connection, such as Wi-Fi®. In another illustrative embodiment, the base station 322 is connected to the medical facility or monitoring center using a direct connection, such as a dedicated network connection, and direct dialup to a server used by the medical facility or monitoring center. The data from the portable monitoring device 302 is transferred to a medical facility or monitoring center where the data is processed and analyzed using the base station 322 and the Internet 324 or other connections, as discussed above.

FIG. 3D is a pictorial diagram showing another illustrative operating environment 330 for downloading and uploading data from/to a portable atrial fibrillation monitoring and detection device 302. In one embodiment, the portable monitoring device 302 is seated in a base station 332 whereby an electrical data interface is used to establish a connection between the portable monitoring device 302 and the base station 332. In one illustrative embodiment, the base station 322 is connected to the Internet 324 using various methods of connection, such as a dialup connection, an acoustic coupler, a wired Ethernet connection, and/or a wireless local area network. In another illustrative embodiment, the base station 322 is connected to the medical facility or monitoring center using a direct connection such as a dedicated network connection and direct dialup to a server used by the medical facility or monitoring center. The data from the portable monitoring device 302 is transferred to a medical facility or monitoring center where the data is processed and analyzed using the base station 332 and the Internet 324 or other connections, as discussed above.

FIG. 4A is a block diagram showing an illustrative embodiment of a circuit 400 for monitoring and detection of atrial fibrillation, including a hardware-based QRS complex signal detector 416 (“QRS detector”). In one illustrative embodiment, the monitoring circuit 400 includes a preamplifier 402 for amplifying the analog electrocardiographic signals detected by electrodes and presented at input terminals 418 and 420. The output of the preamplifier 402 is input to microprocessor 408 and QRS detector 416. In one embodiment, the QRS detector 416 comprises a peak detector. In another embodiment, the QRS detector 416 comprises a peak detector with hysteresis. In yet another embodiment, the QRS detector 416 comprises a signal correlator that matches an input signal to a reference signal (not shown in this figure).

The microprocessor 408 is coupled with a data interface 412 via a data bus 414. The microprocessor 408 is further coupled with a data storage component 410 used for storing data collected by the microprocessor 408 from the preamplifier 402 and for storing software programs executed by the microprocessor 408. A power supply 404 supplies power to all electronic components using power bus 406. In one illustrative embodiment, the power supply 404 comprises a battery. In one illustrative embodiment, the electronic components used in the monitoring circuit 400 are off-the-shelf components. In another illustrative embodiment, the elec-

tronic components comprise application-specific integrated circuits or other custom-made electronics. In one embodiment, the microprocessor is a high-integration component including an analog-to-digital converter and memory and data interfaces.

The microprocessor and other electronic components are selected to have low power consumption. Low power consumption of electronic components enables the monitoring circuit 400 to operate continuously for extended periods of time on a limited power source, such as a battery. It will be appreciated by those skilled in the art that other electronic components not shown in FIG. 4A, such as LCD display, buttons, LED, and the like, may be coupled to the circuit 400.

The operation of the monitoring circuit 400 includes the pre-amplification of the analog electrocardiographic signals at input terminals 418 and 420 by the preamplifier 402. The amplified analog electrocardiographic signal at the output of preamplifier 402 is transmitted to the microprocessor 408 and QRS detector 416. The microprocessor 408 converts the analog electrocardiographic signal from the output of the preamplifier 402 to a digital electrocardiographic signal suitable for manipulation by a software program running on the microprocessor 408. In one embodiment, the software program running on the microprocessor 408 is stored in a designated section of the data storage component 410. In another embodiment, the software program running on the microprocessor 408 may be stored in a different memory component (not shown in this figure) that is distinct from the data storage component 410. Yet in another embodiment, the software program running on the microprocessor 408 may be stored in a memory component integrated with the microprocessor 408 on the same electronic chip.

The microprocessor 408 receives an output signal of the QRS detector 416 when the QRS detector 416 detects a QRS complex signal which periodically appears as a segment of the electrocardiographic signal. The software program running on the microprocessor 408 analyzes the electrocardiographic signal digitized by the microprocessor 408 and the output signal received from the QRS detector 416 and classifies the digitized electrocardiographic signal as either atrial fibrillation or other cardiac rhythms using an algorithm 1000, described below. The QRS detector 416 reduces the computational load on the microprocessor 408 by detecting the QRS complex signal and notifying the microprocessor 408 by the output signal from the QRS detector 416.

If the digitized electrocardiographic signal is classified as atrial fibrillation, then the digitized electrocardiographic signal is retained as digital electrocardiographic data in the data storage component 410. If the digitized electrocardiographic signal is classified as a cardiac rhythm other than atrial fibrillation, then the digitized electrocardiographic data is not retained in the data storage component 410. Thus, only the digitized electrocardiographic data representing atrial fibrillation is retained in the data storage component 410, saving memory space which would otherwise be used for storing all digitized electrocardiographic data. For example, using a method 1100 (FIG. 11A) for detecting atrial fibrillation, discussed below, and the example given above for 90 days of continuous recording of a single channel EKG at 100 samples per second and 10 bits per resolution, requires about 46 MB of storage rather than 927 MB.

An alternative embodiment would store all data that is recorded, but data classified as atrial fibrillation is marked for earlier review and/or transmission to the medical facility or monitoring center.

In one embodiment, the software program running on the microprocessor 408 compresses the digital electrocardio-

graphic data before storing the digital electrocardiographic data in the data storage component 410. Such compression effectively increases the storage capacity of the data storage component 410. In one embodiment, the monitoring circuit 400 gives an indication to the user of the portable monitoring device 202 (FIG. 2A) that the electrocardiographic data retained in the data storage component 410 is ready for retrieval. In one embodiment, the indication to the user is produced when a predetermined amount of data has been retained in the data storage component 410. In another embodiment, the indication to the user is produced when a predetermined amount of time has elapsed. Those skilled in the art will appreciate that the indication to the user may be produced based on criteria other than those mentioned above. The user of the portable monitoring device 202 retrieves the electrocardiographic data retained in the data storage component 410 by one of the methods discussed above with respect to FIGS. 3A-3D. The electrocardiographic data may be analyzed further by more advanced methods after retrieval.

FIG. 4B is a block diagram showing another illustrative embodiment of a circuit 450 for monitoring and detection of atrial fibrillation. The components and operation of the circuit 450 are substantially similar to the circuit 400 described above with respect to FIG. 4A, except for lacking the QRS detector 416 shown in FIG. 4A. The functions performed by the QRS detector 416 in circuit 400, are performed by a microprocessor 458 under software control. Therefore, the software program stored in a data storage component 460 is executed by the microprocessor 458 to cause the detection of an analog electrocardiographic signal, including a periodic QRS complex segment. The analog electrocardiographic signal is input at input terminals 468 and 470, amplified by a preamplifier 452, and transmitted to the microprocessor 458.

As discussed above with respect to FIG. 4A, the microprocessor 458 digitizes the analog electrocardiographic signal which is used by the software program to detect the periodic QRS complex. The operation of the circuit 450 is otherwise the same as the circuit 400 discussed above. As discussed above, it will be appreciated by those skilled in the art that other electronic components not shown in FIG. 4B, such as LCD display, buttons, LEDs, and the like, may be coupled to the circuit 450.

FIG. 5 shows a signal 500 representing a heart rhythm. The heart rhythm signal 500 comprises a repeating pattern of several distinct segments, including an intermittent event referred to in the art as the QRS complex 502. The QRS complex 502 comprises a peak 504. The time interval between two consecutive peaks 504 is the interbeat interval, or RR interval 506. The peak 504 is one of the QRS complex 502 features which can be used to detect a QRS complex 502. An instantaneous heart rate can be defined as the inverse of the RR interval 506, that is, instantaneous heart rate equals $1/RR\text{-interval}$ (or $60/RR\text{-interval}$, for beats per minute), for each RR interval 506.

The detection methods 1100 discussed below in more detail with respect to FIG. 11A is used to detect atrial fibrillation by analyzing an electrocardiogram signal 500 with a high degree of accuracy. A discrimination method 1180 discussed below with respect to FIG. 11B shares some of the steps of the detection method 1100, but is directed to discriminating a detected pattern to determine if an arrhythmia is of a type where intervention is indicated. QRS detection methods 1200 are disclosed and discussed with reference to FIG. 12. The disclosed arrhythmia detection and discrimination methods 1100, 1180 are generally based on analyzing the variability of the RR interval 506 to detect and discriminate charac-

teristic of fibrillation. Detection method 1100 uses the actual time of occurrence of the QRS complexes 502 to detect atrial fibrillation.

FIG. 6 is a pictorial diagram of a heart signal fragment 600 including the QRS complex 602 of a representative heart rhythm. The QRS complex 602 comprises a wave valley section Q, a peak section R, and another valley section S. As discussed above, the QRS complex appears periodically in a heart rhythm. In the present method, the time of appearance of each QRS complex 602 is used to detect the variability of the heart rhythm.

FIG. 7 is a pictorial diagram comparing illustrative box plots 700 of values obtained for atrial fibrillation 704 and normal heart rhythm 724, using data from the atrial fibrillation and normal sinus rhythm databases of PhysioNet. Goldberger, A. L., et al., *PhysioBank, Physio Toolkit, and PhysioNet: Components of a New Research Resource for Complex Physiologic Signals*, *Circulation* 101(23):e215-e220 2000 (June 13). The box plots 704 and 724 are constructed based on the calculations described in FIG. 11A, which represent a measure of the local deviation of the heart rate. The local deviation is closely related to variance, indicating the variability of heart rate. Bassingthwaighe, J. B. and Raymond, G. M., *Evaluation of the Dispersional Analysis Method for Fractal Time Series*, 23(4) *Ann. Biomed. Eng.* 491 (1995). The vertical axis of box plots 700 is the median of median values for heart rate deviation.

The box plot 704 for a typical atrial fibrillation pattern shows a mean value 708, an upper edge 710 indicating the 75th percentile located above the mean 708, a lower edge 712 indicating the 25th percentile located below the mean 708, an upper line 702 indicating 1.5 interquartile (interquartile range is a measure of spread or dispersion and is the difference between the 75th percentile and the 25th percentile) above the mean 708, and a lower line 706 indicating 1.5 interquartile below the mean 708.

In contrast, the box plot 724 for a normal heart rhythm, comprising a mean value 728, an upper edge 730 indicating 75th percentile located above the mean 728, a lower edge 732 indicating 25th percentile located below the mean 708, an upper line 722 indicating 1.5 interquartile above the mean 728, and a lower line 726 indicating 1.5 interquartile below the mean 728, is much more compact.

Based on the variability of heart rate indicated by box plots 704 and 724, significant discrimination between atrial fibrillation and normal sinus rhythm exists, which discrimination is detectable by the method 1100 (FIG. 11A), discussed below, using a median of median values for heart rate deviation. A median of a number of statistical samples is significant because the median is a non-linear average value representing the statistical samples and is defined as the middle value of a sorted list of the statistical samples. It is non-linear with respect to the values of the statistical samples because the value of the median does not change with value of each statistical sample, in contrast to a mean value of the same samples. (The mean value changes linearly with the changes in the values of the statistical samples because the mean is equal to the sum of the values of all the statistical samples divided by the number of the statistical samples.) Thus, the median value is not sensitive to and does not change as a result of changes in sample values at the extreme ends of a statistical population.

FIG. 8 is an illustrative plot 800 of values for sensitivity versus [1-specificity] (one minus specificity) with a variable threshold for detection of atrial fibrillation. The plot 800 comprises a receiver operator curve ("ROC") 806. This ROC 806 relates the sensitivity value 804 versus one minus speci-

ficity (1-specificity) value **802**, calculated based on different threshold values for the present embodiment comprising a median of median values for heart rate deviation. A median of median values for heart rate deviation, discussed above with respect to FIG. 7, above a given threshold value is considered to indicate atrial fibrillation subject to error rates defined by sensitivity and specificity values. Clearly, if the selected threshold is too low, the low sensitivity for detecting AF will be very good (near or equal to 1.0) but false positives will be high, resulting in poor specificity. Conversely, if the threshold is too high, false positives will be reduced, but actual AF events will be missed (false negatives).

Errors in detection of atrial fibrillation are classified as false positives ("FP") and false negatives ("FN"), as discussed above in the background section. Threshold values are selected such that sensitivity and specificity values are maximized. The bend in the ROC **806** corresponds to a threshold that results in minimal error, that is, maximal sensitivity and specificity.

FIG. 9 is an illustrative plot **900** of a number of RR intervals **902** used to detect AF versus area under the ROC **904**. The plot **900** comprises an area under ROC curve **906** obtained by plotting the area under each ROC **806** (e.g., FIG. 8) versus number of RR intervals **902** used in calculating the median of median values for heart rate deviation. Sensitivity and specificity increase when the number of RR intervals **902** increases, resulting in a larger area under the ROC **904**, which has a maximum value of 1. The bend in the area under ROC curve **906** corresponds to the number of RR intervals **902** at which the area under ROC curve **906** is near maximum, and increasing the number of RR intervals **902** has less effect to increase the performance of the method, as measured by the area under ROC curve **904** value. Therefore, the use of a larger number of RR intervals **902** only marginally increases the area under ROC curve **906** while increasing the computational load on a portable monitoring device **202**. Therefore, by plotting the area under ROC curve **906**, a near optimal number of RR intervals **902** may be obtained, minimizing the number of RR intervals **902** to be used in calculations while maximizing the sensitivity and specificity defined by the corresponding ROC **806**.

For example, if **19** RR intervals **902** are used for computation, a threshold may be chosen that provides a sensitivity value of 98.0% and specificity value of 98.7%. The above-mentioned sensitivity and specificity values are close to those resulting from using 7 RR intervals **902** (98.0% and 97.2%, respectively), but the cost of computation and storage with 19 RR intervals **902** is greater than with 7 RR intervals **902**.

Persons of skill in the art will understand that the desired sensitivity and specificity may vary depending on a number of factors, including for example a particular patient's medical and physical condition, the nature of the particular application, etc. In an application wherein monitoring is conducted in conjunction with an in situ intervention mechanism such as an implantable defibrillator, for example (see FIG. 11B, and the associated disclosure), the importance of intervention in any potentially life-threatening situation may outweigh the risks and discomfort associated with the intervention. Therefore, the threshold may be chosen to achieve a very high sensitivity, with less concern about specificity.

FIG. 10 is a pictorial diagram showing an illustrative set of three segments of RR intervals **1008**. For the arrhythmia detection algorithm the three segments used include segment J-1 **1002**, segment J **1004**, and segment J+1 **1006**. Each of the segments J-1 **1002**, J **1004**, and J+1 **1006** comprises an equal number of RR intervals **902**. Each RR interval is measured

based on the arrival time of each QRS complex **502**, as shown in FIG. 5. The above-mentioned segments are used in method **1100** discussed below.

For the preferred arrhythmia discrimination method **1180** (see, FIG. 11B) disclosed herein, only a single segment, for example, segment J **1004**, is used for computation. As discussed above, the segment J **1004** comprises a predetermined number of RR intervals **1008**. Although the illustrative segments shown in FIG. 10 comprise seven heart beat intervals, as discussed above different numbers of heart beat intervals may be selected to comprise an analysis segment. For example, in a preferred embodiment, the analysis segments comprise between three and nineteen heart beat intervals.

FIG. 11A is a flow diagram of an illustrative atrial fibrillation detection method **1100**. The method **1100** measures the variability of heart rate using the instantaneous heart rate based on actual arrival times of QRS signals **502**. The method **1100** further compares a non-linear value representing the variability of heart rate to a selected threshold. The method **1100** determines the existence of atrial fibrillation based on the result of the comparison. The flow diagram proceeds to block **1110** where the duration of each RR interval **1008** is determined within each of a number of segments, for example, the three segments J-1 **1002**, J **1004**, and J+1 **1006** shown in FIG. 10. It will be appreciated by those skilled in the art that any number of segments may be used for this calculation and the choice of three segments is for the purpose of illustration only and is not to be construed as a limitation on the invention. The flow diagram proceeds to block **1120** where instantaneous heart rates corresponding to each RR interval **1108** are determined within each of the segments J-1 **1002**, J **1004**, and J+1 **1006** separately.

In block **1122** the mean value of the instantaneous heart rates are calculated for each segment. In block **1125** the mean values of each of the segments J-1 **1002**, J **1004**, and J+1 **1006** are subtracted. In block **1130** the linear trend is removed to improve estimation of variability of instantaneous heart rate. In block **1140** the absolute value of the deviation from mean with linear trend removed is determined for each RR interval **1108** within each of the segments J-1 **1002**, J **1004**, and J+1 **1006**. In block **1150** the median of absolute deviation from mean for each RR interval **1108** is determined. In block **1160** the median of medians of all three segments J-1 **1002**, J **1004**, and J+1 **1006** is obtained. In block **1165** the median of medians of all three segments J-1 **1002**, J **1004**, and J+1 **1006** is compared with a chosen threshold value. If the median of medians of all three segments J-1 **1002**, J **1004**, and J+1 **1006** is greater than the chosen threshold, then existence of atrial fibrillation is probable **1170** in segment J **1004**. Otherwise, atrial fibrillation is unlikely to exist **1175** in segment J **1004**.

FIG. 11B is a flow diagram of an illustrative life-threatening arrhythmia discrimination method **1180** and is similar to the flow diagram of FIG. 11A in relevant portions. As such, only the differences between the two flow diagrams are described below with respect to FIG. 11B. As noted above, the life-threatening arrhythmia discrimination method **1180** uses a single segment of data J **1004** (FIG. 10), rather than multiple segments discussed with respect to FIG. 11A. Blocks **1180-1192** of FIG. 11B generally follow the same procedures described with respect to blocks **1100-1150** in FIG. 11A. A number N of RR intervals **1008** that comprise a segment is selected **1182**, and the duration of each RR interval **1108** is used to determine an instantaneous heart rate **1184** for each interval. The mean ("M") of the instantaneous heart rate values for the segment is calculated **1185**. The mean is subtracted from the instantaneous heart rate values **1186**, and the linear trend is removed **1188**. The absolute deviation (the

absolute value of the result from **1188**) is calculated **1190** for each RR interval **1108** in the segment, and the absolute deviation median value (“V”) is identified **1192**.

At block **1193** a result is calculated that is used to determine if an electric shock or other intervention is indicated. It has been found that very good specificity and sensitivity for determining if intervention is appropriate can be achieved using a result comprising a linear combination of the instantaneous heart rate mean, M, and the median of the absolute deviation, V. In particular, a linear combination of M and V can be used to obtain a result that is then compared with a desired threshold, wherein if the result exceeds the threshold then intervention is indicated. This linear combination may be represented as: $(A*M)+(B*V)$, where A and B are empirically obtained constant coefficient values.

In the current embodiment the empirically determined coefficients, A and B, have values in the ranges of 1.70 to 2.00 and -0.50 to -0.60 respectively. The coefficients A and B have preferred values of 1.875 and -0.53125, respectively. At block **1194** the result obtained at block **1193** is compared with a desired threshold. If the threshold is exceeded, the method proceeds to block **1196** where the method indicates that the type of arrhythmia detected requires electric shock. Otherwise, the method indicates that intervention is not indicated **1198**.

Of course, it is possible to use data from the atrial fibrillation, normal sinus rhythm and ventricular tachyarrhythmia databases, such as the data from PhysioNet™ referenced above, to determine a suitable threshold for use in the present application, using the procedure outlined with reference to FIGS. **8** and **9**.

FIG. **12** is a flow diagram of an illustrative QRS detection method **1200**. As discussed above with respect to FIG. **4B**, method **1200** may be used by a software program executed by the microprocessor **458** to detect a QRS complex **602**. The method **1200** detects the QRS complex **602** by summing up the absolute value of the amplitudes of the signal samples that fall within a QRS complex **602** time window and comparing the sum with a threshold. More specifically, in block **1202**, an IN_QRS flag is reset. In block **1205**, the next signal sample is obtained for detection of the QRS complex **602**. In block **1210**, an amplitude difference between the next signal sample and the immediate previous signal sample is calculated. In block **1215**, an absolute value of the amplitude difference between the next and the immediate previous signal samples is calculated. In block **1220**, the total of the absolute values of amplitude differences over a predetermined time window is calculated. In block **1225**, the total of the absolute values of amplitude differences is compared with a threshold. If the total of the absolute values of amplitude differences is greater than the threshold, the flow diagram proceeds to block **1230** where it is determined whether the time of the next signal sample is within the time window of the QRS complex **602**. Otherwise, the flow diagram proceeds to block **1250**. Back in block **1230**, if the time of the next signal sample is within the QRS complex **602**, the flow diagram proceeds to block **1235** where it is determined whether the total of the absolute values of amplitude differences of the next signal sample is greater than a current maximum QRS amplitude value, MAX_QRS. If the total of the absolute values of amplitude differences is greater than MAX_QRS, the flow diagram proceeds to block **1240** where the time of the next signal sample is marked as a fiducial point. The flow diagram proceeds to block **1245** where the value of the maximum QRS is updated and set to the total of the absolute values of amplitude differences. The flow diagram proceeds to block **1265** where it is determined if more sample signals are available. If more sample signals are

available, the flow diagram proceeds back to step **1205** to get the next signal sample. Otherwise, the flow diagram terminates at block **1270**.

Back in block **1225**, if the total of the absolute values of amplitude differences is not greater than the variation threshold, the flow diagram proceeds to block **1227** where the state of the IN_QRS flag is determined. If the IN_QRS flag is set, the flow diagram proceeds to block **1250**. Otherwise, the flow diagram continues to block **1265**. In block **1250**, the flow determines whether the time distance from the fiducial mark is greater than a maximum QRS time value, MAX_QRSTIME. MAX_QRSTIME indicates the maximum time span that a QRS complex **602** may have. If the time distance from the fiducial mark is greater than the MAX_QRSTIME, the flow diagram proceeds to block **1255** where the MAX_QRS value and IN_QRS flag are reset. The flow diagram proceeds to block **1260**, where the difference between the fiducial time and half the predetermined time window is provided by the method **1200** as the time of the QRS signal. Back in block **1230**, if the time of the next signal is not within the QRS complex **602**, the flow diagram proceeds to block **1232** where an IN_QRS flag is set to indicate the start of a new QRS complex **602**, and a value is set for the maximum QRS. The flow diagram proceeds to block **1265** and continues as discussed above.

The methods and systems described above allow identification of patients at risk due to otherwise undetected atrial fibrillation. For example, studies may be performed to assess the risk as a function of the amount and duration of atrial fibrillation, in the patients known to have paroxysmal atrial fibrillation. These methods and systems could also allow automated or semi-automated treatment of atrial fibrillation, either with medications or electrical shocks (cardioversion).

The methods and systems also allow the prevention of inappropriate defibrillation (shocks) in individuals with an implantable cardiac defibrillator, while still allowing life-saving shocks.

While the preferred embodiment of the invention has been illustrated and described, it will be appreciated that various changes can be made therein without departing from the spirit and scope of the invention. For example, while the methods and systems described above are directed towards the detection of atrial fibrillation, and prevention of inappropriate shocks, other infrequent but clinically significant rhythm disturbances, such as ventricular tachycardia or intermittent high-grade atrioventricular block, may be detected by substantially similar methods and systems.

The embodiments of the invention in which an exclusive property or privilege is claimed are defined as follows:

1. A method for calculating an arrival time for a QRS complex, comprising:
 - obtaining with a wearable or an implantable arrhythmia monitoring and detection device a time sequence comprising equally spaced amplitude signals representing the electrical activity of a heart;
 - selecting a time window defined to include a fixed number of the equally spaced amplitude signals such that the time window has a window width;
 - obtaining from the time sequence a first segment comprising the fixed number of equally spaced amplitude signals, and calculating for the first segment the sum of the absolute value of the differences between each adjacent pair of amplitude signals in the first segment;
 - obtaining from the time sequence subsequent overlapping segments of amplitude signals, and calculating for the subsequent overlapping segments the sum of the absolute value of the differences between each adjacent pair

of amplitude signals in the segment, wherein the step of obtaining subsequent overlapping segments continues until the sum exceeds a predetermined threshold value; when the sum exceeds the predetermined threshold value, setting a flag and recording the corresponding calculated sum in a maximum sum parameter; obtaining from the time sequence subsequent overlapping segments, and calculating for the subsequent overlapping segments the sum of the absolute value of the differences between each pair of amplitude signals in the time window, and if the calculated sum is greater than the maximum sum parameter, resetting the maximum sum parameter to the calculated sum and recording an identifier parameter that identifies the segment, wherein the step of obtaining segments continues until the number of subsequent overlapping segments that have been obtained without resetting the maximum sum parameter exceeds a predetermined number; and calculating the arrival time of the QRS complex as the center of the time window corresponding to the segment identified by the identifier parameter.

2. The method of claim 1, wherein the identifier parameter comprises the end time of the segment corresponding to the identifier parameter, and the center of the time window is calculated by subtracting half of the window size from the identifier parameter.

3. The method of claim 2, wherein the arrival time of the QRS complex is used to calculate a heartbeat RR interval.

4. The method of claim 3, wherein the arrival time of the QRS complex is used to calculate an instantaneous heart rate.

5. The method of claim 2, further comprising resetting the flag and the maximum sum, and repeating the method to calculate a next arrival time of a QRS complex from the time sequence.

6. The method of claim 2, wherein the time sequence comprising equally spaced amplitude signals comprises a digitized continuously recorded electrocardiogram.

7. The method of claim 6, wherein the electrocardiogram is a single channel electrocardiogram recording at least 100 samples per second.

8. The method of claim 1, wherein the fixed number of amplitude signals is not greater than seven amplitude signals.

9. A method for detecting a QRS complex, comprising: obtaining, using a wearable or an implantable arrhythmia monitoring and detection device, a digitized electrocardiogram comprising a time sequence of equally spaced amplitude signals representing the measured electrical activity of a heart;

selecting a time window defined to include a fixed number of the equally spaced amplitude signals such that the time window has a window width;

obtaining from the time sequence a first segment comprising the fixed number of equally spaced amplitude signals, and calculating for the first segment the sum of the absolute value of the differences between each adjacent pair of amplitude signals in the first segment;

obtaining from the time sequence subsequent overlapping segments of amplitude signals, and calculating for the subsequent overlapping segments the sum of the absolute value of the differences between each adjacent pair of amplitude signals in the segment, wherein the step of obtaining subsequent overlapping segments continues until the sum exceeds a predetermined threshold value; when the sum exceeds the predetermined threshold value, setting a flag and recording the corresponding calculated sum in a maximum sum parameter;

obtaining from the time sequence subsequent overlapping segments, and calculating for the subsequent overlapping segments the sum of the absolute value of the differences between each pair of amplitude signals in the time window, and if the calculated sum is greater than the maximum sum parameter, resetting the maximum sum parameter to the calculated sum and recording an identifier parameter that identifies the segment, wherein the step of obtaining segments continues until the number of subsequent overlapping segments that have been obtained without resetting the maximum sum parameter exceeds a predetermined number; and identifying the QRS complex as the segment identified by the identifier parameter.

10. The method of claim 9, wherein the identifier parameter comprises the end time of the segment corresponding to the identifier parameter, and the center of the time window is calculated by subtracting half of the window size from the identifier parameter.

11. The method of claim 10, wherein the arrival time of the QRS complex is used to calculate a heartbeat RR interval.

12. The method of claim 11, wherein the arrival time of the QRS complex is used to calculate an instantaneous heart rate.

13. The method of claim 10, further comprising resetting the flag and the maximum sum, and repeating the method to calculate a next arrival time of a QRS complex from the time sequence.

14. The method of claim 10, wherein the time sequence comprising equally spaced amplitude signals comprises a digitized continuously recorded electrocardiogram.

15. The method of claim 14, wherein the electrocardiogram is a single channel electrocardiogram recording at least 100 samples per second.

16. The method of claim 9, wherein the fixed number of amplitude signals is not greater than seven amplitude signals.

* * * * *

专利名称(译)	长期监测不同心律的辨别力		
公开(公告)号	US9326697	公开(公告)日	2016-05-03
申请号	US14/315061	申请日	2014-06-25
[标]申请(专利权)人(译)	华盛顿大学		
申请(专利权)人(译)	华盛顿大学		
当前申请(专利权)人(译)	华盛顿大学		
[标]发明人	LINKER DAVID THOR		
发明人	LINKER, DAVID THOR		
IPC分类号	A61B5/0452 A61B5/046 A61B5/024 A61B5/0432 A61B5/0408 A61B5/0468 A61B5/0472 A61B5/00 A61N1/37 A61N1/362		
CPC分类号	A61B5/046 A61B5/0031 A61B5/02405 A61B5/0432 A61B5/0468 A61B5/0472 A61B5/04085 A61B5/04325 A61B5/0006 A61B2560/0412 A61B2560/0456 A61N1/3621 A61N1/3702		
审查员(译)	DIETRICH, JOSEPH		
优先权	12/125859 2012-12-04 US 11/253375 2009-12-08 US 60/620598 2004-10-19 US		
其他公开文献	US20150141860A1		
外部链接	Espacenet USPTO		

摘要(译)

一种用于检测心律失常的方法，系统和设备，以及不同类型的心律失常之间的区别，例如以确定是否对心脏施加电击，该设备包括具有检测电活动的电极的可穿戴监视器。连接到具有放大器，微处理器，数据存储装置和电源的嵌入式监视系统的的心脏跳动，所有这些都设置在具有连接到电极的大的远端部分和连接到电极的窄的中间部分的基板上。监视系统。

