



US 20180323865A1

(19) **United States**

(12) **Patent Application Publication**

Ludwig et al.

(10) **Pub. No.: US 2018/0323865 A1**

(43) **Pub. Date: Nov. 8, 2018**

(54) **COMMUNICATIONS IN A MEDICAL DEVICE SYSTEM WITH TEMPORAL OPTIMIZATION**

Publication Classification

(71) Applicant: **CARDIAC PACEMAKERS, INC.**, St. Paul, MN (US)

(72) Inventors: **Jacob M. Ludwig**, Isanti, MN (US); **Michael J. Kane**, St. Paul, MN (US); **Brendan E. Koop**, Ham Lake, MN (US); **William J. Linder**, Golden Valley, MN (US); **Keith R. Maile**, New Brighton, MN (US); **Jeffrey E. Stahmann**, Ramsey, MN (US)

(73) Assignee: **CARDIAC PACEMAKERS, INC.**, St. Paul, MN (US)

(21) Appl. No.: **16/033,852**

(22) Filed: **Jul. 12, 2018**

Related U.S. Application Data

(63) Continuation of application No. 15/058,412, filed on Mar. 2, 2016, now Pat. No. 10,050,700.

(60) Provisional application No. 62/134,752, filed on Mar. 18, 2015.

(51) **Int. Cl.**

H04B 7/24 (2006.01)
A61N 1/372 (2006.01)
A61N 1/362 (2006.01)
A61B 5/00 (2006.01)
H04L 1/12 (2006.01)
H04B 13/00 (2006.01)

(52) **U.S. Cl.**

CPC **H04B 7/24** (2013.01); **A61N 1/37288** (2013.01); **A61N 1/37217** (2013.01); **A61N 1/362** (2013.01); **H04B 13/005** (2013.01); **A61B 5/0028** (2013.01); **A61N 1/37252** (2013.01); **H04L 1/12** (2013.01); **A61B 2560/0209** (2013.01)

(57)

ABSTRACT

Systems and methods for managing communication strategies between implanted medical devices. Methods include temporal optimization relative to one or more identified conditions in the body. A selected characteristic, such as a signal representative or linked to a biological function, is assessed to determine its likely impact on communication capabilities, and one or more communication strategies may be developed to optimize intra-body communication.

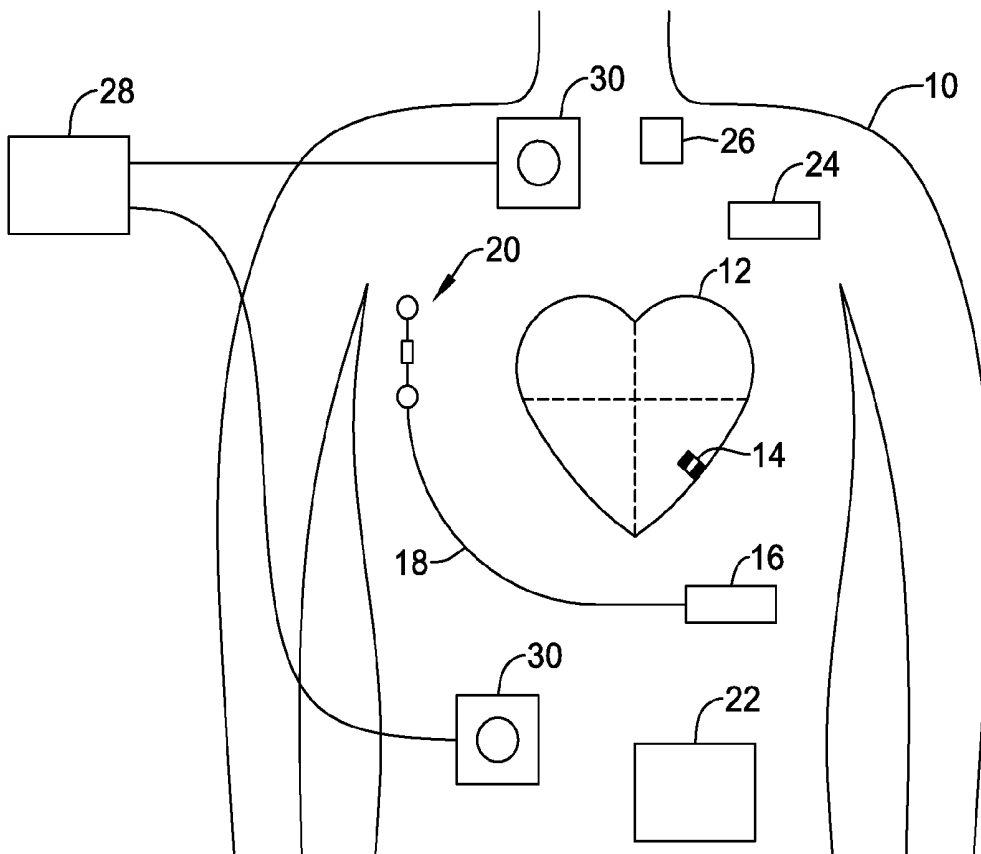

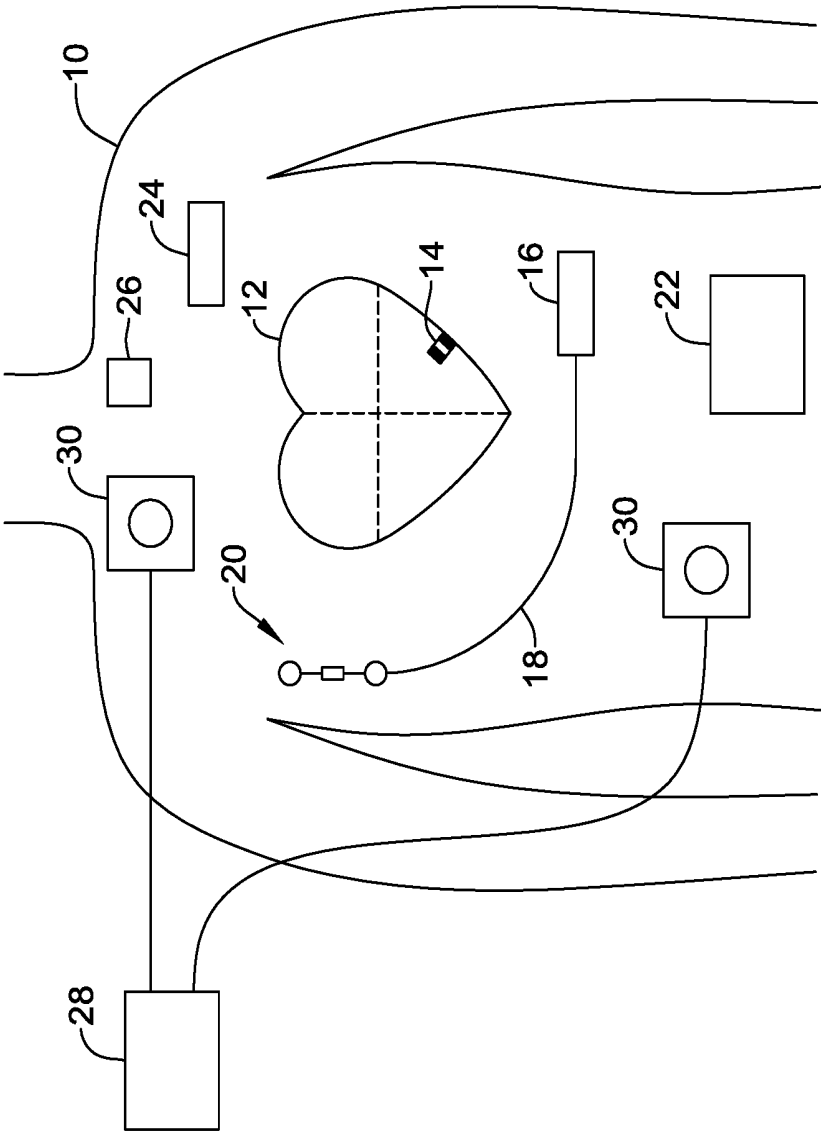

FIG. 1

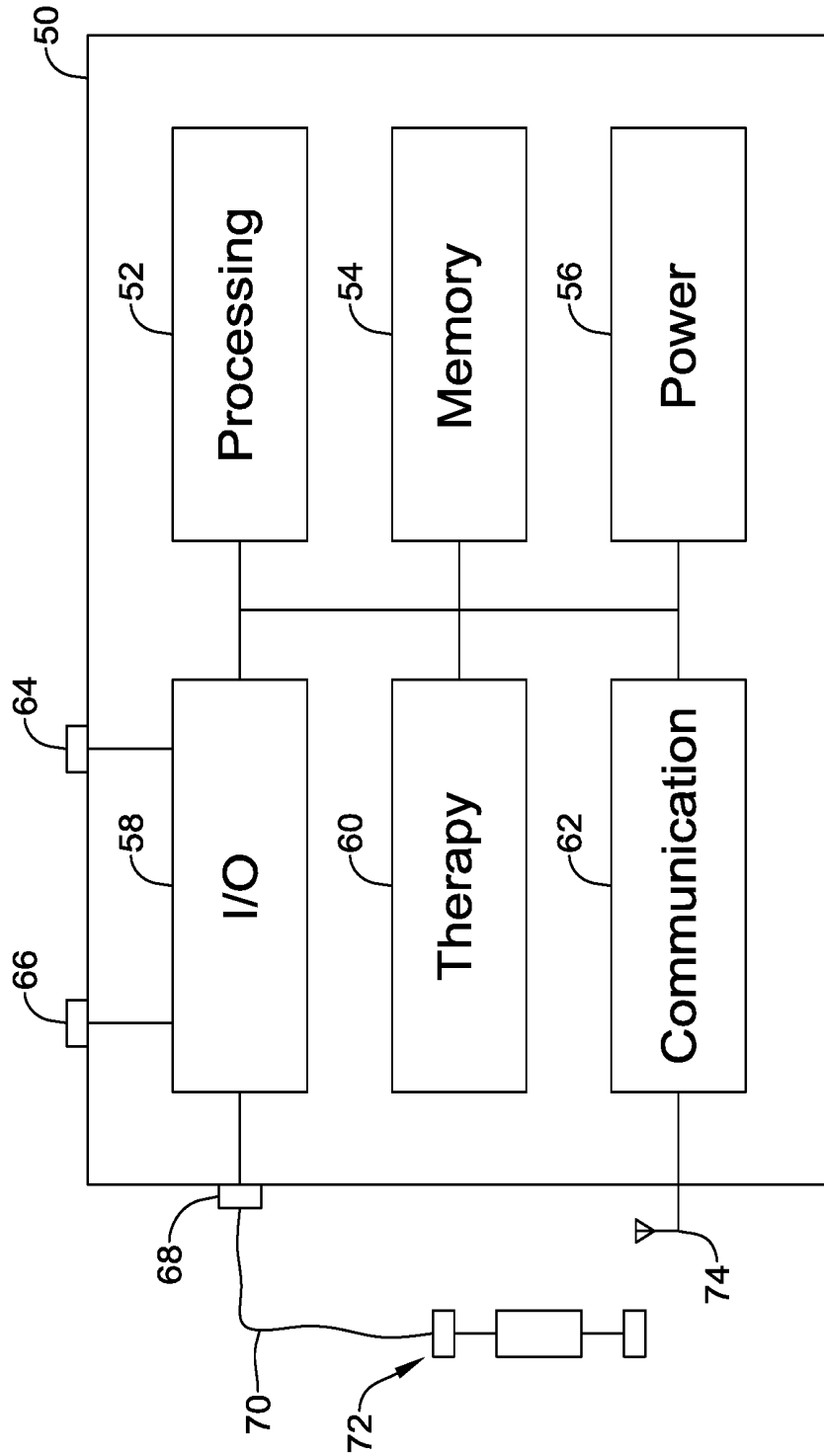

FIG. 2

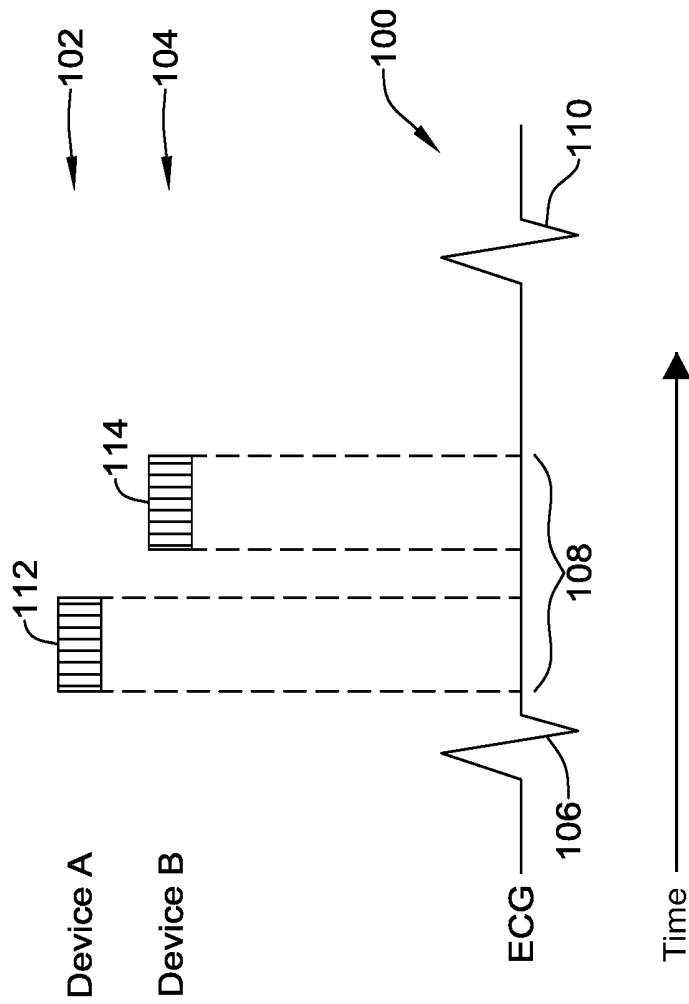

FIG. 3

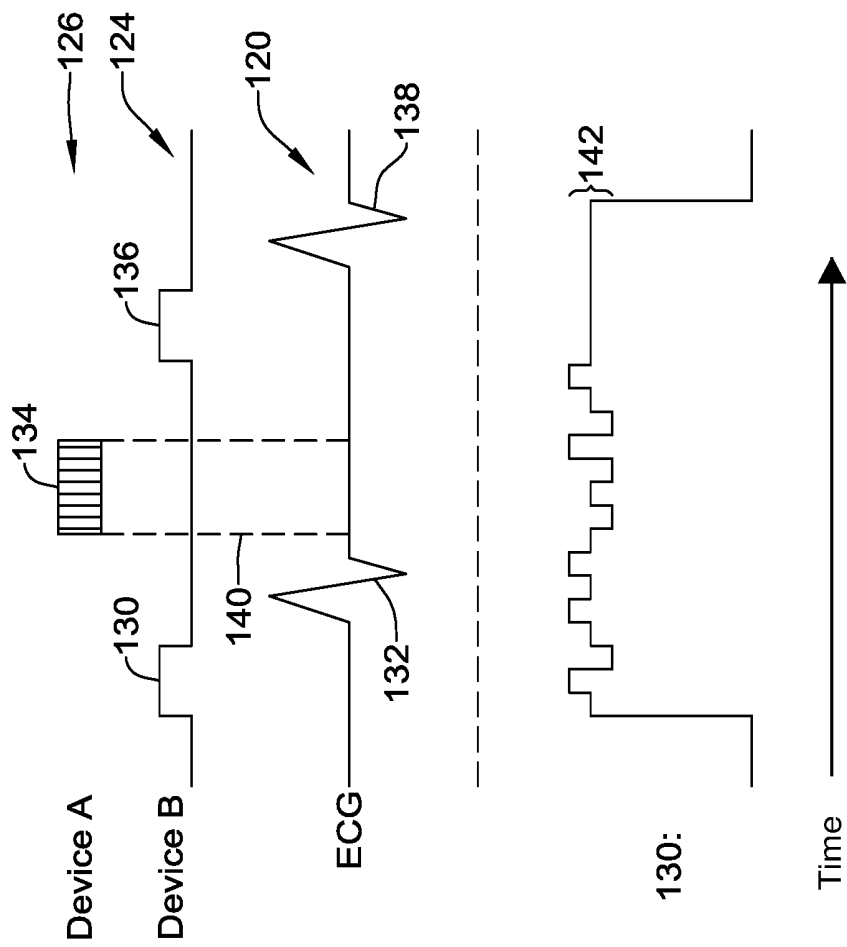

FIG. 4

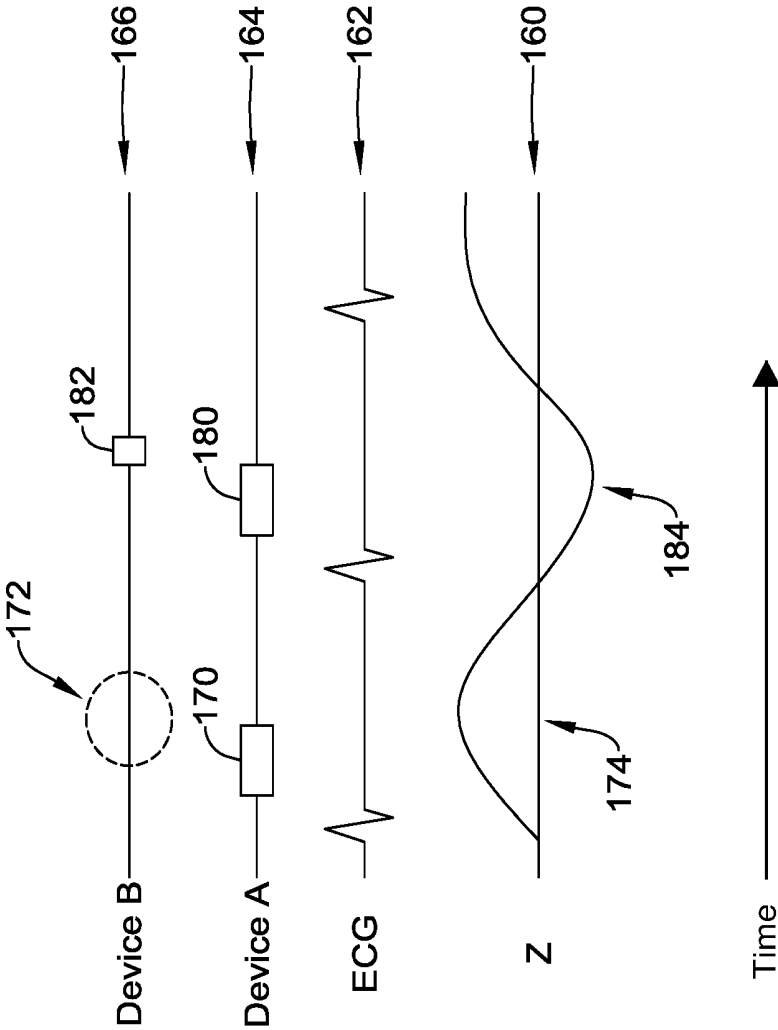

FIG. 5

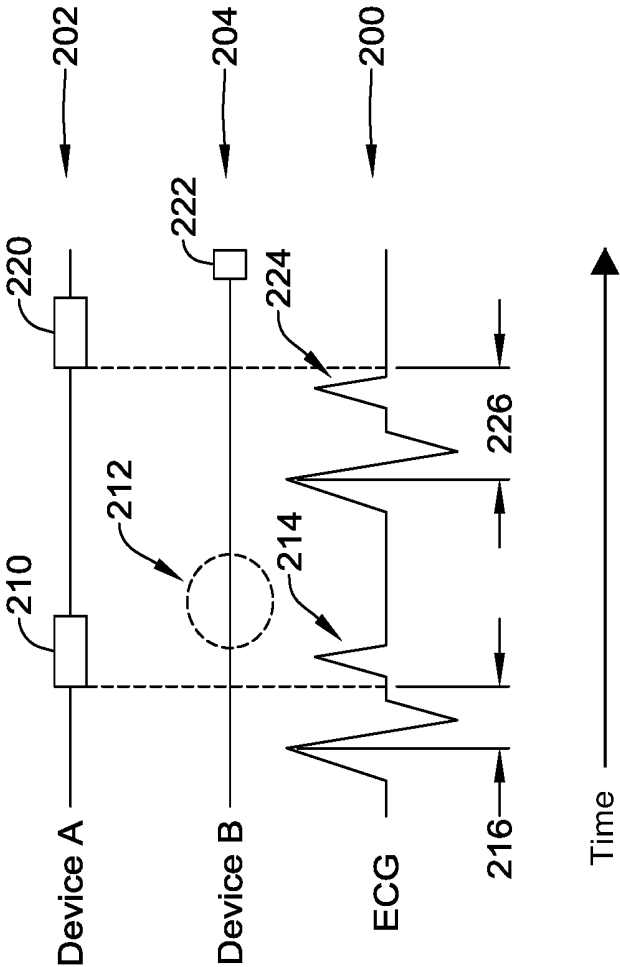

FIG. 6

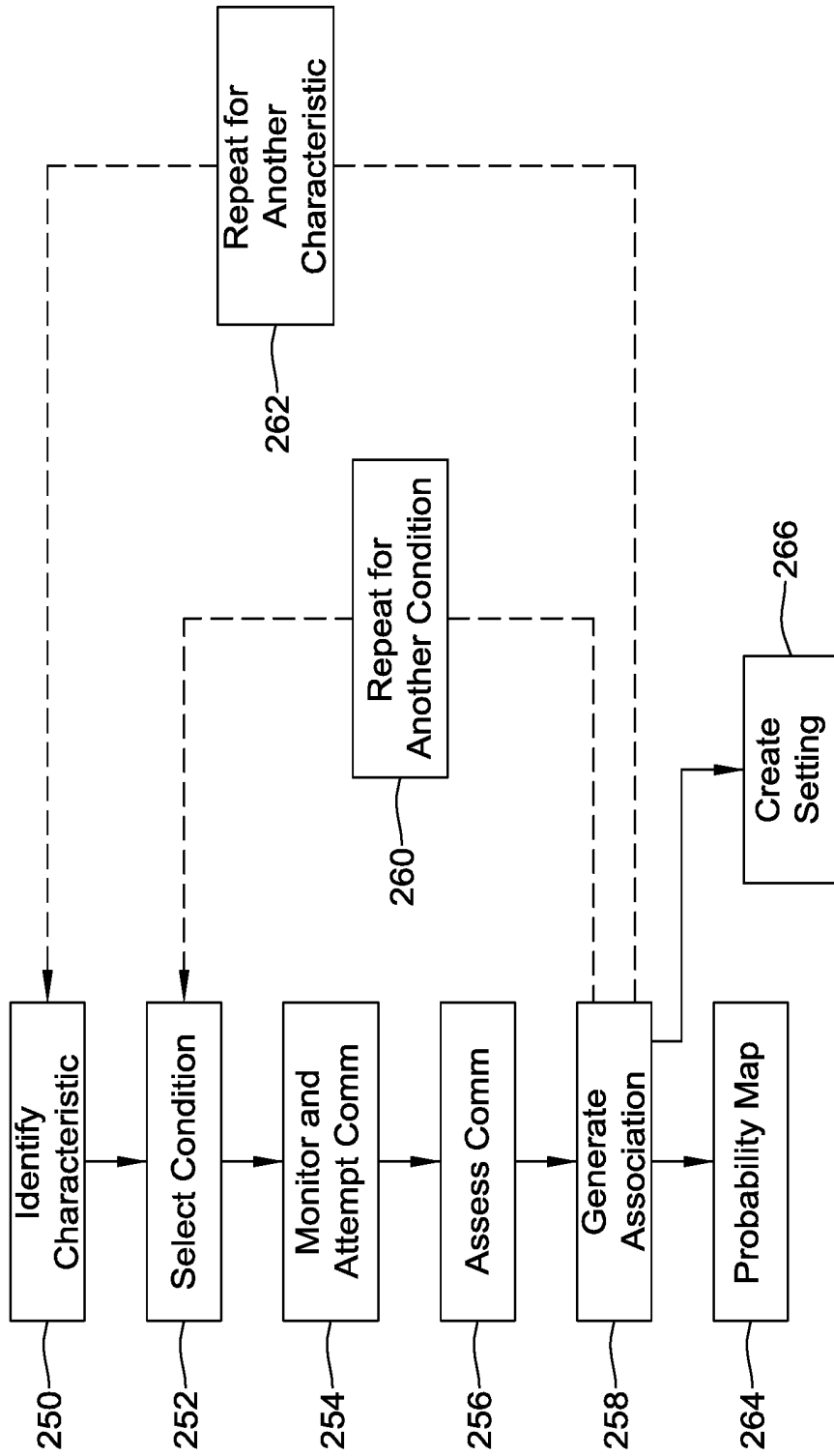

FIG. 7

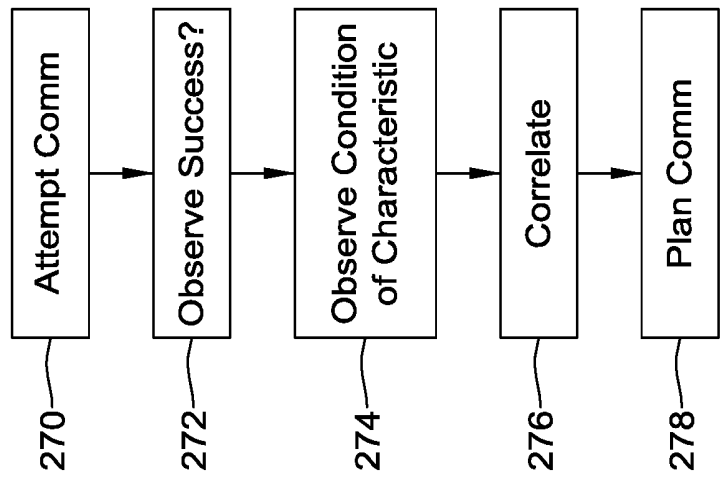

FIG. 8

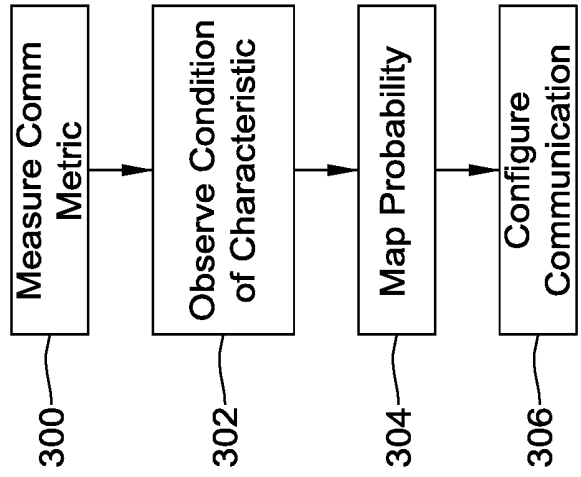

FIG. 9

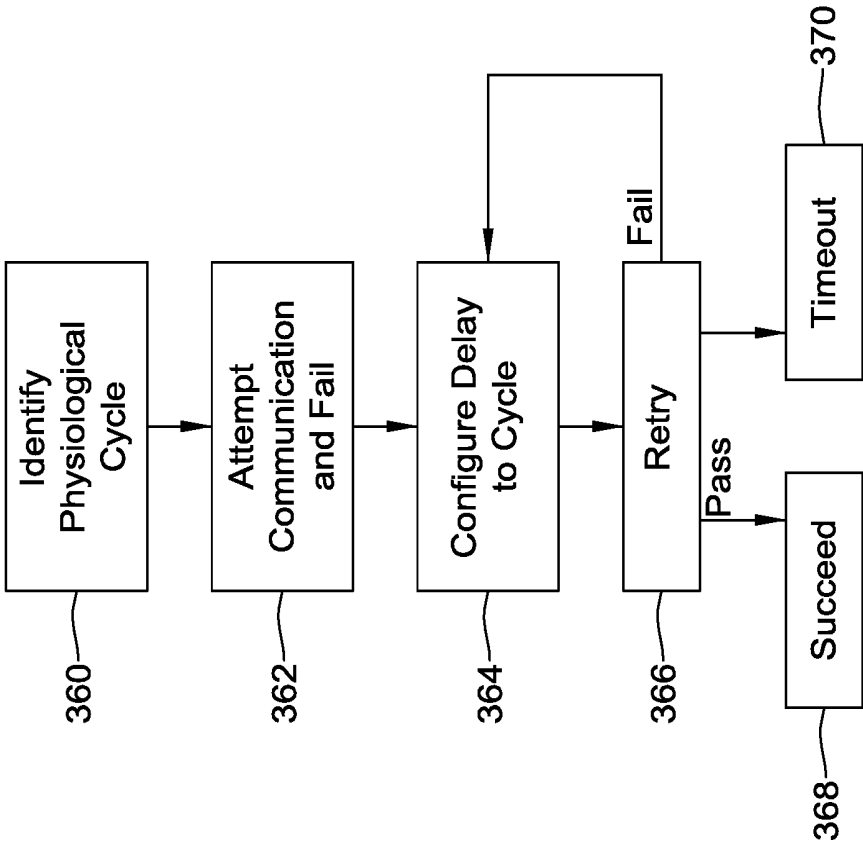

FIG. 10

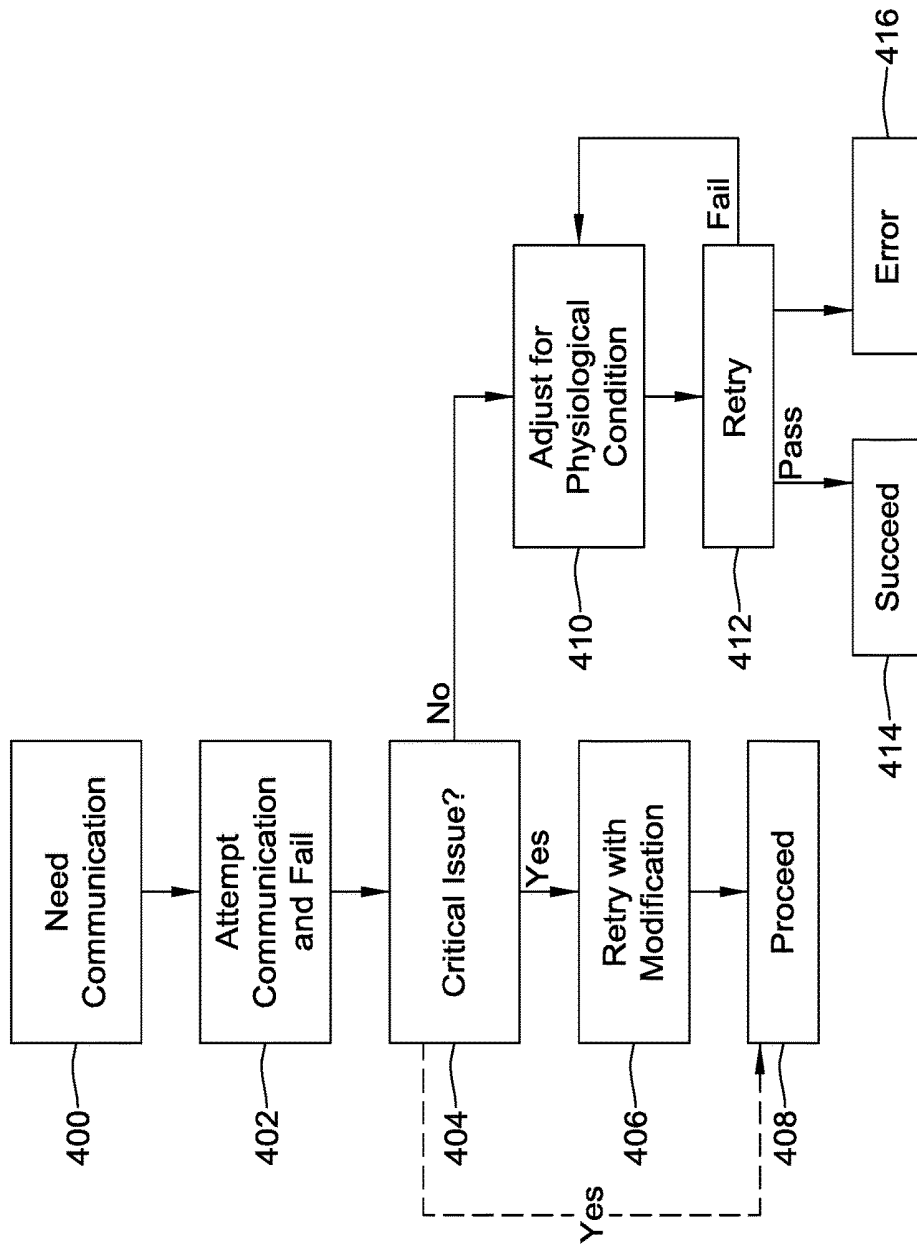

FIG. 11

COMMUNICATIONS IN A MEDICAL DEVICE SYSTEM WITH TEMPORAL OPTIMIZATION

CROSS REFERENCE TO RELATED APPLICATIONS

[0001] The present application is a continuation of U.S. patent application Ser. No. 15/058,412, filed Mar. 2, 2016, which claims the benefit of and priority to U.S. Provisional Patent Application No. 62/134,752, filed Mar. 18, 2015, titled COMMUNICATIONS IN A MEDICAL DEVICE SYSTEM WITH TEMPORAL OPTIMIZATION, the disclosures of which are incorporated herein by reference.

TECHNICAL FIELD

[0002] The present disclosure generally relates to medical devices, and more particularly to communications between medical devices in a multi-device system.

BACKGROUND

[0003] Various active implantable devices are available or in development for treating and/or diagnosing numerous ailments. Some examples include cardiac assist devices, pacemakers, defibrillators, cardiac monitors, neurostimulation and neuromodulation systems, drug and medication pumps, and others. A patient may have multiple implanted devices and may benefit in some circumstances by enabling such devices to communicate with one another. Because these implantable devices are often reliant on battery power, communication between devices should be designed for efficiency and to limit power consumption.

SUMMARY

[0004] The present disclosure relates generally to systems and methods for managing communication strategies with temporal optimization relative to one or more identified conditions in the body.

[0005] A first example is a first medical device comprising: means for communicating with a second implantable medical device; means for identifying a first characteristic having a possible impact on communication success; means for selecting a first condition of the first characteristic on which to trigger an attempt at communication; means for determining that the first condition of the first characteristic is present and attempting communication with the second implantable medical device; means for assessing whether the attempted communication was successful; and means for associating the first condition and first characteristic with a reduced likelihood of communication success if the attempted communication was not successful.

[0006] A second example takes the form of the first medical device of the first example wherein the means for communicating is configured for communication by conducted communication. A third example takes the form of a first medical device as in either of the first two examples wherein the first medical device is configured as an implantable medical device. A fourth example takes the form of a first medical device of any of the first three example, further comprising means for associating the first condition and first characteristic with an improved likelihood of communication success if the attempted communication was successful.

[0007] A fifth example takes the form of a first medical device of any of the first four examples further comprising

optimization means for selecting multiple conditions of the first characteristic and repeatedly operating the means for determining, means for assessing and means for associating for each of multiple conditions of the first characteristic to determine whether the first characteristic can be used to determine a likelihood of communication success.

[0008] A sixth example takes the form of a first medical device of any of the first to fifth examples further comprising means for identifying a second characteristic, wherein the means for determining, means for assessing and means for assessing are operable to test at least a first condition of the second characteristic to determine whether the second characteristic can be used to determine a likelihood of communication success.

[0009] A seventh example takes the form of a first medical device of any of the first to sixth examples wherein the first characteristic is a detected status of a cardiac cycle, and the first condition is the occurrence of one of a cardiac R-wave or a cardiac T-wave. An eighth example takes the form of a first medical device of any of the first to sixth examples wherein the first characteristic is a detected status of a cardiac cycle, and the first condition is the occurrence of a pacing pulse. A ninth example takes the form of a first medical device of any of the first to sixth examples wherein the first characteristic is a detected status of a respiration cycle, and the first condition is the occurrence of one of an exhale or an inhale. A tenth example takes the form of a first medical device of any of the first to sixth examples wherein the first characteristic is a detected a transthoracic impedance, and the first condition is the occurrence of one of a maximum impedance or a minimum impedance. An eleventh example takes the form of a first medical device of any of the first to sixth examples wherein the first characteristic is a cyclic biological phenomenon and the first condition is the occurrence of a recurring event in the cyclic biological phenomenon.

[0010] A twelfth example takes the form of an implantable medical device system comprising a first medical device as of any of the first to eleventh examples and a second implantable medical device configured for communication with the first medical device, wherein the first medical device is an intracardiac pacing device, and the second implantable medical device is a subcutaneous defibrillator.

[0011] A thirteenth example takes the form of an implantable medical device system comprising a first medical device as in any of the first to eleventh examples, and a second implantable medical device configured for communication with the first medical device, wherein the first medical device is a subcutaneous defibrillator, and the second implantable medical device is an intracardiac pacing device.

[0012] A fourteenth example is a first medical device comprising means for communicating with a second medical device; means for determining a first condition of a first characteristic is present; and means for modifying communication with the second implantable medical device based on the determination; wherein at least one of the first and second medical devices is implantable. A fifteenth example takes the form of a first medical device as in the fourteenth example wherein the first characteristic is a cyclic biological phenomenon and the first condition is the occurrence of a recurring event in the cyclic biological phenomenon.

[0013] A sixteenth example is a first medical device comprising a communication module for communicating with a

second implantable medical device and a controller operatively coupled to the communication module for at least one of receiving or transmitting messages, the controller configured to optimize communication by: identifying a first characteristic having a possible impact on communication success; selecting a first condition of the first characteristic on which to trigger an attempt at communication; determining that the first condition of the first characteristic is present and attempting communication with the second implantable medical device; assessing whether the attempted communication was successful; and if the attempted communication was not successful, associating the first condition and first characteristic with a reduced likelihood of communication success.

[0014] A seventeenth example takes the form of the first medical device of the sixteenth example wherein the communication module is configured for communication by conducted communication. An eighteenth example takes the form of the first medical device of either the sixteenth or seventeenth examples wherein the first medical device is configured as an implantable medical device. A nineteenth example takes the form of the first medical device of any of the sixteenth to eighteenth examples, wherein the controller is further configured to associate the first condition and first characteristic with an improved likelihood of communication success if the attempted communication was successful. A twentieth example takes the form of the first medical device of any of the sixteenth to nineteenth examples, wherein the controller is configured to further optimize communication by selecting multiple conditions of the first characteristic and repeating the determining and assessing steps for each of multiple conditions of the first characteristic to determine whether the first characteristic can be used to determine a likelihood of communication success. A twenty-first example takes the form of the first medical device of any of the sixteenth to twentieth examples, wherein the controller is configured to identify a second characteristic and test at least a first condition of the second characteristic to determine whether the second characteristic can be used to determine a likelihood of communication success.

[0015] A twenty-second example takes the form of the first medical device of any of the sixteenth to twenty-first examples wherein the first characteristic is a detected status of a cardiac cycle, and the first condition is the occurrence of one of a cardiac R-wave or a cardiac T-wave. A twenty-third example takes the form of the first medical device of any of the sixteenth to twenty-first examples wherein the first characteristic is a detected status of a cardiac cycle, and the first condition is the occurrence of a pacing pulse. A twenty-fourth example takes the form of the first medical device of any of the sixteenth to twenty-first examples wherein the first characteristic is a detected status of a respiration cycle, and the first condition is the occurrence of one of an exhale or an inhale. A twenty-fifth example takes the form of the first medical device of any of the sixteenth to twenty-first examples wherein the first characteristic is a detected transthoracic impedance, and the first condition is the occurrence of one of a maximum impedance or a minimum impedance. A twenty-sixth example takes the form of the first medical device of any of the sixteenth to twenty-first examples wherein the first characteristic is a

cyclic biological phenomenon and the first condition is the occurrence of a recurring event in the cyclic biological phenomenon.

[0016] A twenty-seventh example takes the form of an implantable medical device system comprising a first medical device as in any of the sixteenth to twenty-sixth examples and a second implantable medical device configured for communication with the first medical device, wherein the first medical device is an intracardiac pacing device, and the second implantable medical device is a subcutaneous defibrillator. A twenty-eighth example takes the form of an implantable medical device system comprising a first medical device as in any of the sixteenth to twenty-sixth examples, and a second implantable medical device configured for communication with the first medical device, wherein the first medical device is a subcutaneous defibrillator, and the second implantable medical device is an intracardiac pacing device.

[0017] A twenty-ninth example is a first medical device comprising a communication module for communicating with a second medical device and a controller operatively coupled to the communication module messages, the controller configured to optimize communication by: determining a first condition of a first characteristic is present; and modifying communication with the second implantable medical device based on the determination; wherein at least one of the first and second medical devices is implantable.

[0018] A thirtieth example takes the form of the first medical device of the twenty-ninth example wherein the first characteristic is a cyclic biological phenomenon and the first condition is the occurrence of a recurring event in the cyclic biological phenomenon. A thirty-first example takes the form of the first medical device of the thirtieth example wherein the cyclic biological phenomenon is one of a respiration cycle or a cardiac cycle.

[0019] A thirty-second example is a method of communication with an implantable medical device comprising: identifying a characteristic having a possible impact on communication success; selecting a condition of the characteristic on which to trigger an attempt at communication; attempting communication based on the condition of the characteristic occurring; and assessing whether the communication was likely successful.

[0020] A thirty-third example takes the form of a method as in the thirty-second example, further comprising: if the communication was successful, associating the characteristic and condition with an improved likelihood of communication success; or if the communication was not successful, associating the characteristic and condition with a reduced likelihood of communication success.

[0021] A thirty-fourth example takes the form of a method as in either of the thirty-second or thirty-third examples wherein the characteristic is a cyclic biological phenomenon and the condition is the occurrence of a recurring event in the cyclic biological phenomenon. A thirty-fifth example takes the form of a method as in the thirty-fourth example wherein the cyclic biological phenomenon is one of a respiration cycle or a cardiac cycle.

[0022] The above summary is not intended to describe each embodiment or every implementation of the present disclosure. Advantages and attainments, together with a more complete understanding of the disclosure, will become

apparent and appreciated by referring to the following description and claims taken in conjunction with the accompanying drawings.

BRIEF DESCRIPTION OF THE DRAWINGS

[0023] The disclosure may be more completely understood in consideration of the following description of various illustrative embodiments in connection with the accompanying drawings, in which:

[0024] FIG. 1 illustrates a patient having a plurality of implantable medical devices;

[0025] FIG. 2 illustrates a block diagram of an implantable medical device;

[0026] FIGS. 3-6 are schematic diagrams illustrating communications pulses relative to biological signals;

[0027] FIGS. 7-11 are flow diagrams of a several illustrative methods that may be implemented by a medical device or medical device system.

[0028] While the disclosure is amenable to various modifications and alternative forms, specifics thereof have been shown by way of example in the drawings and will be described in detail. It should be understood, however, that the intention is not to limit aspects of the disclosure to the particular illustrative embodiments described. On the contrary, the intention is to cover all modifications, equivalents, and alternatives falling within the spirit and scope of the disclosure.

DESCRIPTION

[0029] The following description should be read with reference to the drawings in which similar elements in different drawings are numbered the same. The description and the drawings, which are not necessarily to scale, depict illustrative embodiments and are not intended to limit the scope of the disclosure.

[0030] FIG. 1 illustrates a patient having a plurality of implantable medical devices. A patient, 10 is shown having a leadless cardiac pacemaker (LCP) 14 implanted inside the heart 12. A subcutaneous implantable defibrillator (SICD) 16 having a left axillary canister and lead 18 extending to electrodes 20 is also shown. The patient may also have an insulin pump 22, a pain pump 24 for delivering pain medication to the shoulder, and/or a nerve stimulator 26 having a lead (not shown) extending to the neck or head.

[0031] Other devices could be substituted for those shown in FIG. 1, and the positions shown for each device are not intended to be limiting. Some additional or alternative examples include other pacemakers or defibrillators such as those with transvenous, intracardiac, epicardial, or substernal leads and/or electrodes, a cardiac monitor, left ventricular assist device, spinal cord stimulator, vagus nerve stimulator, gastric electric stimulator, sacral nerve stimulator, and/or any other implantable medical device.

[0032] In some embodiments an implanted device may be in communication with one or more extracorporeal devices. The extracorporeal device(s) may be affixed to the patient in a wearable configuration. The extracorporeal device(s) may provide a therapy, for example a nerve stimulation therapy, muscle simulation therapy and/or respiration therapy (e.g. continuation positive airway pressure therapy). Additionally or alternatively the extracorporeal device may provide a diagnostic function, for example a cardiac monitoring function or/and a respiratory monitoring function. Additionally

or alternatively the extracorporeal device may serve as a communication link between an implanted device and a device not in physical contact with the patient (i.e. remote from the body). In some embodiments one or more parts/elements of a device or system may be implanted and other portions may be extracorporeal (e.g. a drug pump or a continuous glucose monitor).

[0033] These various systems may be interrogated by an external device or a "programmer" 28, which may optionally use one or more skin electrodes 30 to assist with communication to an implanted device. Skin electrodes 30 may be used for conducted communication with an implantable device. Conducted communication is communication via electrical signals which propagate via patient tissue and are generated by more or less ordinary electrodes. By using the existing electrodes, conducted communication does not rely on an antenna and an oscillator/resonant circuit having a tuned center frequency common to both transmitter and receiver.

[0034] For other communication approaches such as RF or inductive communication, the programmer 28 may instead use a programming wand or may have an antenna integral with the programmer 28 housing for communication. Though not shown in detail, the programmer 28 may include any suitable user interface, including a screen, buttons, keyboard, touchscreen, speakers, and various other features widely known in the art.

[0035] It is unlikely a single patient 10 would have all of the different systems implanted as shown in FIG. 1. For purposes of the present invention, it is assumed that a patient may have at least two implantable systems simultaneously, and it may be beneficial to facilitate communication between the at least two implantable systems. The mode for communication between two implanted systems may be conducted communication, though other approaches (optical, acoustic, inductive or RF, for example) could be used instead.

[0036] FIG. 2 illustrates a block diagram of an implantable medical device. The illustration indicates various functional blocks within a device 50, including a processing block 52, memory 54, power supply 56, input/output circuitry 58, therapy circuitry 60, and communication circuitry 62. The I/O circuitry 58 can be coupled to one or more electrodes 64, 66 on the device 50 housing, and may also couple to a header 68 for attachment to one or more leads 70 having additional electrodes 72. The communication circuitry 62 may be coupled to an antenna 74 for radio communication (such as Medradio, ISM, or other RF) and/or may couple via the I/O circuitry 58 to a combination of electrodes 64, 66, 72, for conducted communication.

[0037] The processing block 52 will generally control operations in the device 50 and may include a microprocessor or microcontroller and/or other circuitry and logic suitable to its purpose. Processing block 52 may include dedicated circuits or logic for device functions such as converting analog signals to digital data, processing digital signals, detecting events in a biological signal, etc. The memory block may include RAM, ROM, flash and/or other memory circuits for storing device parameters, programming code, and data related to the use, status, and history of the device 50. The power supply 56 typically includes one to several batteries, which may or may not be rechargeable

depending on the device 50. For rechargeable systems there would additionally be charging circuitry for the battery (not shown).

[0038] The I/O circuitry 58 may include various switches or multiplexors for selecting inputs and outputs for use. I/O circuitry 58 may also include filtering circuitry and amplifiers for pre-processing input signals. In some applications the I/O circuitry will include an H-Bridge to facilitate high power outputs, though other circuit designs may also be used. Therapy block 60 may include capacitors and charging circuits, modulators, and frequency generators for providing electrical outputs. For devices such as insulin and drug pumps the therapy circuit 60 may include a pump or pump actuator coupled to a delivery system for outputting therapeutic material, rather than using the I/O circuitry 58 as would be typical for systems that generate an electrical therapy output.

[0039] Communications circuitry 62 may include a frequency generator/oscillator and mixer for creating output signals to transmit via the antenna 74. Some devices 50 may include a separate ASIC for the communications circuitry 62, for example. For devices using an inductive communication output, an inductive coil may be included. Devices may also use optical or acoustic communication approaches, and suitable circuits, transducers, generators and receivers may be included for these modes of communication as well or instead of those discussed above.

[0040] As those skilled in the art will understand, additional circuits may be provided beyond those shown in FIG. 2. For example, some devices 50 may include a Reed switch or other magnetically reactive element to facilitate magnet wakeup or reset of the device by a user. Some systems may omit one or more blocks, for example, an implantable cardiac monitor can omit therapy block 60, and an LCP may exclude the header 68 for coupling to lead 70.

[0041] In several embodiments, the present invention is directed toward the management and optimization of conducted communication between two implanted medical devices. For example, an LCP may communicate with an SICD. The LCP may, for example, provide a detected heartbeat rate to the SICD in order to assist the SICD in making a therapy determination. In another example, the SICD may request status from the LCP or may direct the LCP to deliver pacing pulses.

[0042] Other combinations of systems may use conducted communication between devices for various reasons. For example, if a patient has both a drug pump and a spinal cord stimulator, the drug pump may communicate to the spinal cord stimulator that it is in need of servicing, such that both systems may use their internal annunciating mechanisms to alert the patient that the drug pump requires service. As integrated systems develop, it may become possible to develop simplified devices that omit, for example, standard telemetry or annunciator circuits, and instead use conducted communication to another device that includes full telemetry and annunciator circuits. If telemetry and/or annunciator circuits are omitted in one or more devices, the devices may become smaller and power consumption may be reduced. Thus conducted communication optimization may facilitate development of smaller and/or longer lasting devices in addition to facilitating inter-device coordination for therapy purposes.

[0043] FIGS. 3-6 are schematic diagrams illustrating communications packets relative to biological signals. Con-

ducted communication taking place within the body is subject to interference from various biological functions. Respiration and the cardiac cycle are two particular cyclic biological functions of interest, though any other biological function, cyclic or not, may also be addressed using the methods and devices herein.

[0044] FIG. 3 illustrates an ECG signal at 100, and communications by Device A at 102 and Device B at 104. The ECG shows a QRS complex (a heartbeat) at 106 followed by an interval 108, and another beat at 110. In this illustration, Device A sends a data packet 112 during the interval 108 between beats 106, 110, and Device B responds with a packet at 114 during the same interval 108. In another embodiment, Device B may respond after the subsequent beat at 110.

[0045] The phrase "data packet" is used for convenience and should be understood as generically including any type of message sent from one device to another. No particular message/frame structure, type of data, size or other meaning should be implied.

[0046] In FIG. 3, the data packets are shown as being sent independent of therapy output by either Device A or Device B. FIG. 4 shows a scheme in which Device B is configured to embed communications in a therapy output. The ECG is shown at 120, and the therapy output of Device B is shown at 124, while the communications from Device A are shown at 126. The therapy output 124 includes pacing pulses 130 and 136, which trigger beats 132 and 138 respectively on the ECG 120.

[0047] A detail view of pacing pulse 130 is shown below, and it is seen at 142 that the shape of the pacing pulse 130 includes amplitude modulation embedding a data packet. Other approaches to embedding information in a pacing pulse can be used; the illustration is simplified in FIG. 4 since the present invention is not limited to embedding data in a therapy output nor is it limited to communicating via therapy output-encoded data. Preferably, the embedded data 142 does not affect the effectiveness of therapy of the pacing pulse 130.

[0048] Device A is designed to recognize the data 142 embedded in the pacing pulse 130. In this example, Device A responds with a data packet after some delay such that data packet 134 follows the end of the QRS complex of beat 132. In an alternative, Device A could send data packet 134 and Device B would respond with a message embedded in pacing pulse 136.

[0049] The signals for conducted communication are generally intended to have amplitudes that will not cause cardiac or skeletal muscle contraction, with the exception of the case in which the conducted communication is embedded in a stimulus signal, such as pacing pulse 130 with data 132. The patient should not be aware of the conducted communication signal.

[0050] In FIG. 4, the amplitude, duration and/or frequency content of the data packet 134 would be selected to avoid stimulating muscle (skeletal or cardiac). Delivery of the data packet 134 during the QRS complex 132 could cause Device B to miss the signal or interpret it as part of the QRS complex 132. Therefore, as indicated at 140, the data packet 134 is preferably delivered after the conclusion of the QRS complex for beat 132, and preferably ends before delivery of the next pacing pulse 136.

[0051] One approach to delivering data packet 134 would be to call for a fixed delay after the conclusion of the pacing

pulse **130**, such as a 300 millisecond delay allowing for the (typically wide) paced QRS complex for beat **132** to be finished. Another approach would be to sense the ECG **120** for termination of the QRS. Each approach has limitations, however. A fixed period may not account for other portions of the ECG, such as the T-wave and/or S-T segment, which can vary in amplitude between patients and even within a patient based on the patient's posture, activity level, etc. Detecting the end of the QRS can be highly dependent on the location of the electrodes used to sense the ECG **120**. Moreover, it may be more effective if both Device A and Device B know when the data packet **134** is expected. Thus a temporal optimization may be highly useful to enhance communication reliability.

[0052] As used in the present disclosure, the ECG represents the electrical state of the patient's heart, and is a "characteristic" of the patient. The occurrence of a QRS complex, or other event, in the ECG represents a "condition" of the ECG characteristic. Other characteristics and conditions of characteristics are discussed below.

[0053] FIG. 5 illustrates another characteristic and an illustrative example of its use. Here, a transthoracic impedance is shown at **160**, an ECG is shown at **162**, and the communication packets for Device A and Device B are shown at **164** and **166**, respectively. The transthoracic impedance **160** may vary with patient movement, such as respiration. In this sequence, the beats of the ECG are avoided by Device A when it sends out data packets **170** and **180**. However, Device B fails to respond at **172** to data packet **170**. Reviewing the transthoracic impedance suggests that a high transthoracic impedance at **174** may have negatively affected communication of data packet **170**. This may be treated as a "high condition" of the "characteristic" of transthoracic impedance.

[0054] As a result, in this embodiment, the method includes delivering the next packet **180**, both outside of the QRS complex of ECG **162**, but also at a point where the transthoracic impedance **160** is low as shown at **184**. This time, the data packet **180** is received by device B, generating an acknowledgement or other responsive output at **182**. Analysis of the observed characteristic (impedance), suggests that the condition of low transthoracic impedance at **184** may have positively impacted the success of data packet **180**. The illustrative system may record one or both of the success and failure as indicating a likely connection between transthoracic impedance and communication success. Reviewing FIG. 5 alongside FIG. 4 shows that a temporal optimization may take into account multiple characteristics.

[0055] The QRS complex is not the only condition which may arise within the ECG characteristic; the T-wave and P-wave, for example, or S-T segment elevation, are also potential conditions that may impact communication success. In FIG. 6, the ECG is represented at **200**, and communications activity of Devices A and B is shown at **202** and **204** respectively.

[0056] Device A attempts communication at **210**, but the communication fails to be observed by Device B, which does not reply at **212** as expected. Closer review of the ECG **200** indicates that the QRS complex is followed by a prominent T-wave shown at **214**. Either of Device A or Device B may assess the ECG and the failed communication attempt and identify a likely relationship, and make an adjustment to the timing of a later communication attempt.

[0057] In an alternative example, Device A may not identify whether there is a prominent T-wave; it simply knows that the communication attempt at **210** was not acknowledged. Therefore Device A can adjust the delay after the R-wave detection, shown at **216**, by increasing or decreasing the delay. Here, Device A adjusts such that the next attempt in which data packet **220** is sent occurs with a greater delay **226**. This time, the T-wave **224** is missed, and the data packet **220** is received and acknowledged by Device B at **222**. As illustrated by FIGS. 4-6, not only are there multiple characteristics to be potentially aware of, but also multiple conditions within the characteristics.

[0058] For purposes herein, the ECG, transthoracic impedance, and status of the respiration cycle are three possible characteristics. Another characteristic may include posture, which may be determined by use of an accelerometer or through analysis of some other signal such as skeletal muscle activity, the shape or amplitude of a respiration signal, or ECG morphology from one or more sensing vectors. If the patient is exercising, there may be a detectable cycle associated with motion artifacts generated with the patient's stride. For example, at each foot-strike if the patient is running, a monitored biological electrical signal or a monitored accelerometer output, for example, may demonstrate a motion artifact. Testing communication success relative to the detected motion artifact may be useful in determining whether and how communication success can be ensured when the artifact is identified. In some examples, the QRS and to cardiac signal may actually not be of significant importance to communication success, and other factors may be deemed more likely to create marginal or poor communication, such as those non-ECG items just noted.

[0059] It should be noted in this context that an implantable medical device communication system may have multiple reasons for communicating. Some communication is not urgent, as for example, a periodic device status check communication. Other communication is urgent, as for example, a request that a device deliver therapy or prepare to have therapy delivered by a second device. A specific example would be the combination of an LCP and SICD, where the SICD may non-urgently request battery status from the LCP periodically (i.e. weekly), and may on occasion urgently request that the LCP provide a beat rate measurement confirmation prior to the SICD delivering a high power defibrillation shock to the patient, where the LCP rate measurement confirmation would be used to prevent inappropriate shocks due to malsensing.

[0060] For another example, an SICD used in combination with a spinal cord stimulator (SCS) may use an urgent communication to allow the SICD to warn the SCS that a high energy defibrillation shock, which could overwhelm the SCS sensing circuitry inputs, is about to be delivered so that the SCS can suspend sensing or isolate its sensing circuitry during the shock. Temporal optimization may be performed using the non-urgent communication requests, to give greater confidence that an urgent request will be received successfully.

[0061] FIGS. 7-11 are flow diagrams of a several illustrative methods that may be implemented by a medical device or medical device system. Starting with FIG. 7, the illustrative method begins with identifying a characteristic at **250**, then selecting a condition at **252** to assess for its potential impact on communication. Next, the condition and charac-

teristic are monitored and an attempt at communication is made, as shown at **254**. The communication effort is then assessed at **256**. The assessment at **256** may be a simple pass/fail assessment, or may include a more complex analysis such as review of the signal-to-noise ratio, signal strength, frame or bit error rate, presence or lack of acknowledgement/handshake, presence or lack of an intended response (therapy or other), measurement of link availability or speed, or other feature of the communication attempt, for example as discussed in commonly assigned U.S. Provisional Patent Application 62/134,726, filed Mar. 18, 2015 and titled COMMUNICATIONS IN A MEDICAL DEVICE SYSTEM WITH LINK QUALITY ASSESSMENT the disclosure of which is incorporated herein by reference.

[0062] While several examples rely on electrical signals (myopotential or neuropotential, for example) and potential interference with conducted communication, other combinations are possible. For example, an acoustic communication system may consider heart sounds or respiratory sounds, rather than myopotentials.

[0063] Using the assessment at **256**, an association can be generated at **258**. Steps **252**, **254** and **256** may be repeated for other conditions, as indicated at **260**, of the same characteristic. In an additional loop indicated at **262**, other characteristics may also be assessed. If desired, further combinations of characteristics and conditions may be concatenated for testing as well. Optionally, a probability map may be generated, as indicated at **264**. Such a map may include possible communication pathways (such as links and configurations of devices) and sets of probabilities of success given particular parameters, for example. A probability map may be used by an individual device or system to plot out communication strategies, or it may be exported for diagnostic and system design purposes. In addition, as indicated at **266**, settings for the system under test may also be generated, including, for example, if-then type rules for planning communication timing relative to identified conditions and characteristics.

[0064] For example, the ECG may be identified as a characteristic at **250**, and a condition in which the ECG is above a threshold amplitude may be identified, with testing performed at **254** by attempting to communicate a data packet with the ECG at certain amplitude levels, using a looping approach indicated by block **260**. Attempts may be made, for example, with the ECG showing an R-wave as one condition, a T-wave as another condition, and being near baseline during the interval between a T-wave and a subsequent P-wave as yet another condition. The attempts are assessed at **256**, and an association is constructed at **258**. A probability map can be generated at **264**. The system can be appropriately set at **266** to provide temporal optimization such that communication attempts occur at times within the ECG cycle selected to maximize the chance of success. As part of the setting step at **266**, or the mapping at **264**, data may be communicated to other implanted devices regarding the settings to be applied.

[0065] If desired and available, variations on the communication signal may also be applied, for example, if variable output signal amplitude or data rate are available, different communication variations may also be applied to assess their effect on communication success. For example, a system may determine whether reducing the data rate or increasing signal amplitude can affect the likelihood of

communication success. The same characteristic and condition can be repeatedly tested with different configurations of the communication signal.

[0066] The illustration of FIG. 7 takes a prospective, forward looking approach in which communication ability is assessed under selected conditions. FIG. 8 shows an alternative approach in which, given a particular communication attempt, a backward looking review can be undertaken to troubleshoot failures. In FIG. 8, communication is attempted by sending a data packet from one device to another, as shown at **270**. The success, or failure, of the attempt is observed at **272**, and then a physiological characteristic and its condition at the time of the communication attempt is observed as noted at **274**. A correlation is determined, as shown at **276**, and subsequent communication can be planned accordingly by, for example, increasing or reducing a delay relative to an observable phenomenon. The correlation stored at **276** can be tested and retested over time to determine whether it accurately reflects real world conditions.

[0067] As an example, with a patient who exercises, there may be a cyclic motion artifact in a detected biological signal associated with the patient's stride, or swim stroke, or other repetitive motion. An attempt at communication is made at **270** and fails at **272**. It is then determined at **274** how the failed communication attempt related, in time, to the motion artifact. The motion artifact may be determined by sensing the communication channel or by observing a separately sensed channel. A correlation is presumed at **276** and stored for later reference, and plans are made at **278** to ensure that a subsequent attempt at communication will occur with a different temporal relationship to the motion artifact (if such an artifact is observed). The plan at **278** may then be communicated throughout the system, if desired.

[0068] FIG. 9 provides another example. A communication metric, such as amplitude or signal-to-noise ratio, is measured for a given data packet or communication attempt at **300**. A potentially related physiological condition is also observed, as shown at **302**. A probability of success given the communication metric is generated at **304**. The communication strategy is then configured at **306**, using the condition of the physiological characteristic observed at **302**.

[0069] As an example, the respiratory cycle of a patient may be observed by tracking transthoracic impedance over time. A communication attempt may be made and characteristics observed in relation to the communication attempt would be measured in block **300**. The status of the respiration cycle is observed using block **302**, and mapping of the probability of communication success based on the point in the respiration cycle at which communication is attempted can be generated at **304**. Then communication attempts for future use can be configured in block **306**.

[0070] If, for example, the phase of respiration at which the transthoracic impedance is at a minimum shows better communication metrics than the point of maximum transthoracic impedance, then the map of probability at **304** would be used to configure communications to occur while minimum transthoracic impedance is occurring. On the other hand, the probability mapping at **304** may determine from the observed communication metrics that the respiration cycle is not likely to impact communication success or failure. If that is the case, then a different characteristic and condition may instead be assessed, and the system would

record data indicating that a configuration based on respiration cycle may not be helpful.

[0071] FIG. 10 shows another example. A physiological cycle is identified at 360. Communication is attempted and fails at 362. (Steps 360 and 362 may be reversed with the physiological cycle identified in response to or after failure). A delay relative to an event within the observed cycle is then configured at 364, and a retry scheduled at 366. If the retry fails, the method returns to 364 and configures a different delay relative to the cycle. Multiple retries may be attempted. A retry limit may be enforced, for example, with no more than 3-10 retries (or more or fewer, as desired). Eventually the system either retries to success at 368, or reaches a timeout 370 in which case an alert may be set relative to communication difficulty.

[0072] FIG. 11 shows another example in which different treatment is given to critical and non-critical issues. Here, beginning with a need for communication at 400, an attempt is made at 402 and fails. It is then determined whether a critical or urgent issue has arisen at 404. For some urgent issues, the method may execute one or more retries at 406 and then proceed regardless of success, or the retry may be bypassed entirely as indicated by the dashed line.

[0073] For example, if an SCD is attempting to cause an LCP to deliver antitachycardia pacing (ATP) because the SCD is about to prepare for defibrillation therapy, no retries may be called if the retry interrupts therapy preparation, as the patient may be suffering a life-threatening situation. On the other hand, if the SCD can attempt to call for ATP without interrupting therapy preparations (which may take several seconds as capacitors are charged to therapy levels), one or several retries 406 may be attempted during therapy preparation.

[0074] If a non-critical issue is occurring at 404, then an adjustment is made for a physiological condition at 410 and a number of retries may be attempted in a loop between 410 and 412. Upon success, the parameters 414 of a successful communication attempt would be stored for later use. If the number of retries is limited at 412 and the maximum retry limit is reached, then the system may set an error flag or announce an error condition 416.

[0075] A first non-limiting example takes the form of a first medical device comprising: means for communicating with a second implantable medical device; means for identifying a first characteristic having a possible impact on communication success; means for selecting a first condition of the first characteristic on which to trigger an attempt at communication; means for determining that the first condition of the first characteristic is present and attempting communication with the second implantable medical device; means for assessing whether the attempted communication was successful; and means for associating the first condition and first characteristic with a reduced likelihood of communication success if the attempted communication was not successful.

[0076] In this first non-limiting example, the means for communicating may take the form of, for example, the communication subsystem 62 in FIG. 2, optionally including the antenna 74 or, alternatively, for a conducted communication system, the I/O subsystem 58 of FIG. 2 and one or more of electrodes 64, 66 or 72. The means for identifying a first characteristic condition may include an instruction set or sets for performing a step or steps as described in association with block 250 of FIG. 7, which may be stored

in memory 54 of FIG. 2 or which can be performed by a processing circuitry 52, or such means may include dedicated circuitry, for example, of the processing circuitry 52.

[0077] Further in the first non-limiting example, the means for selecting a first condition of the first characteristic on which to trigger an attempt at communication may include an instruction set stored in memory 54 for operation by processing circuitry 52 of FIG. 2, instructions embedded in processing circuitry 52 of FIG. 2, or dedicated circuitry of the processing circuitry 52 of FIG. 2, which are configured to perform a step as described in association with block 252 of FIG. 7. Also in the first non-limiting example, the means for determining that the first condition of the first characteristic is present and attempting communication with the second implantable medical device may include an instruction set stored in memory 54 for operation by processing circuitry 52 of FIG. 2, instructions embedded in processing circuitry 52 of FIG. 2, or dedicated circuitry of the processing circuitry 52 of FIG. 2, which are configured to perform a step as described in association with block 255 of FIG. 7, in which the processing circuitry is further configured to direct and/or make use of the communications circuitry 62 and antenna 74 and/or the I/O circuitry 58 and one or more of electrodes 64, 66 or 72.

[0078] In the first non-limiting example, the noted means for assessing whether the attempted communication was successful may include an instruction set stored in memory 54 for operation by processing circuitry 52 of FIG. 2, instructions embedded in processing circuitry 52 of FIG. 2, or dedicated circuitry of the processing circuitry 52 of FIG. 2, which are configured to perform a step as described in association with block 256 of FIG. 7. Finally in the first non-limiting example, the means for associating the first condition and first characteristic with a reduced likelihood of communication success if the attempted communication was not successful may include an instruction set stored in memory 54 for operation by processing circuitry 52 of FIG. 2, instructions embedded in processing circuitry 52 of FIG. 2, or dedicated circuitry of the processing circuitry 52 of FIG. 2, which are configured to perform a step as described in association with block 258 of FIG. 7, which is configured for operation in the event the attempted communication is not successful.

[0079] An extension of this first non-limiting example may further comprise a means for associating the first condition and first characteristic with an improved likelihood of communication success if the attempted communication was successful, which may include an instruction set stored in memory 54 for operation by processing circuitry 52 of FIG. 2, instructions embedded in processing circuitry 52 of FIG. 2, or dedicated circuitry of the processing circuitry 52 of FIG. 2, which are configured to perform a step as described in association with block 258 of FIG. 7, which is configured for operation in the event the attempted communication is not successful.

[0080] Another extension of this first non-limiting example further comprises optimization means for selecting multiple conditions of the first characteristic and repeatedly operating the means for determining, means for assessing and means for associating for each of multiple conditions of the first characteristic to determine whether the first characteristic can be used to determine a likelihood of communication success, wherein the optimization means may include an instruction set stored in memory 54 for operation

by processing circuitry 52 of FIG. 2, instructions embedded in processing circuitry 52 of FIG. 2, or dedicated circuitry of the processing circuitry 52 of FIG. 2, which are configured to perform a step as described in association with block 260 of FIG. 7.

[0081] Still another extension of this first non-limiting example further comprises a means for identifying a second characteristic, wherein the means for determining, means for assessing and means for assessing are operable to test at least a first condition of the second characteristic to determine whether the second characteristic can be used to determine a likelihood of communication success, wherein the means for identifying a second characteristic may include an instruction set stored in memory 54 for operation by processing circuitry 52 of FIG. 2, instructions embedded in processing circuitry 52 of FIG. 2, or dedicated circuitry of the processing circuitry 52 of FIG. 2, which are configured to perform a step as described in association with block 262 of FIG. 7.

[0082] A second non-limiting example takes the form of a first medical device comprising means for communicating with a second medical device; means for determining a first condition of a first characteristic is present; and means for modifying communication with the second implantable medical device based on the determination; wherein at least one of the first and second medical devices is implantable.

[0083] In this second non-limiting example, the means for communicating may take the form of, for example, the communication subsystem 62 in FIG. 2, optionally including the antenna 74 or, alternatively, for a conducted communication system, the I/O subsystem 58 of FIG. 2 and one or more of electrodes 64, 66 or 72.

[0084] Also in this second non-limiting example, the means for determining a first condition of a first characteristic is present may include an instruction set stored in memory 54 for operation by processing circuitry 52 of FIG. 2, instructions embedded in processing circuitry 52 of FIG. 2, or dedicated circuitry of the processing circuitry 52 of FIG. 2, which are configured to obtain information regarding one or more of the state of the patient's ECG, the patient's measurable impedance, a biological cycle, or other measurable element such as the output of an accelerometer to determine a condition of a first characteristic.

[0085] Finally in the second non-limiting example, the means for modifying may include an instruction set stored in memory 54 for operation by processing circuitry 52 of FIG. 2, instructions embedded in processing circuitry 52 of FIG. 2, or dedicated circuitry of the processing circuitry 52 of FIG. 2, which are configured to adjust one or more parameters of a communication subsystem 62 in FIG. 2, optionally including the antenna 74 or, alternatively, for a conducted communication system, the I/O subsystem of FIG. 2.

[0086] Those skilled in the art will recognize that the present disclosure may be manifested in a variety of forms other than the specific examples described and contemplated herein. For instance, as described herein, various examples include one or more modules described as performing various functions. However, other examples may include additional modules that split the described functions up over more modules than that described herein. Additionally, other examples may consolidate the described functions into fewer modules. Accordingly, departure in form and detail may be made without departing from the scope and spirit of the present disclosure as described in the appended claims.

What is claimed is:

1. A first medical device comprising a communication module for communicating with a second medical device and a controller operatively coupled to the communication module, the controller configured to optimize communication by:

determining a first condition of a first characteristic is present; and

modifying communication with the second implantable medical device based on the determination;

wherein at least one of the first and second medical devices is implantable; and

wherein the first characteristic is a cyclic biological phenomenon and the first condition is the occurrence of a recurring event in the cyclic biological phenomenon.

2. The first medical device of claim 1, wherein the communication module is configured for communication by conducted communication.

3. The first medical device of claim 1, wherein the first medical device is configured as an implantable medical device.

4. The first medical device of claim 1, wherein the controller is configured to further optimize communication by sequentially modifying communication with the second implantable device based on the determination in a plurality of communication attempts.

5. The first medical device of claim 1, wherein the first characteristic is a detected status of a cardiac cycle, and the first condition is the occurrence of one of a cardiac R-wave or a cardiac T-wave.

6. The first medical device of claim 1, wherein the first characteristic is a detected status of a cardiac cycle, and the first condition is the occurrence of a pacing pulse.

7. The first medical device of claim 1, wherein the cyclic biological phenomenon is a repetitive patient movement.

8. The first medical device of claim 1, wherein the first characteristic is a detected status of a respiration cycle, and the first condition is the occurrence of one of an exhale or an inhale.

9. The first medical device of claim 1, wherein the first characteristic is a detected a transthoracic impedance, and the first condition is the occurrence of one of a maximum impedance or a minimum impedance.

10. An implantable medical device system comprising a first medical device as recited in claim 1 and a second implantable medical device configured for communication with the first medical device, wherein the first medical device is an intracardiac pacing device, and the second implantable medical device is a subcutaneous defibrillator.

11. An implantable medical device system comprising a first medical device as recited in claim 1, and a second implantable medical device configured for communication with the first medical device, wherein the first medical device is a subcutaneous defibrillator, and the second implantable medical device is an intracardiac pacing device.

12. The first implantable medical device of claim 1 further comprising a plurality of electrodes coupled to sensing circuitry adapted to sense the first characteristic and detect the first condition.

13. A first medical device comprising a communication module for communicating with a second medical device and a controller operatively coupled to the communication module, the controller configured to communicate with the second medical device by:

identifying a present need for communication;
 attempt a first communication using first communication strategy;
 determine whether the first communication was unsuccessful;
 in response to determining that the first communication was unsuccessful, determine whether the present need for communication relates to a critical issue and:
 if the present need for communication relates to a critical issue, adopt a first communication retry strategy; and
 if the present need for communication does not relate to a critical issue, adopt a second communication retry strategy.

14. The first medical device of claim **13** wherein the first communication retry strategy comprises omitting a retry and proceeding to deliver therapy to the patient, and the second communication retry strategy comprises retrying communication one or more times.

15. The first medical device of claim **14** wherein the operational circuitry is configured to modify a communication setting for use in the second communication retry strategy by:

detecting a first condition of a first characteristic of the patient; and
 selecting the modified communication setting in light of the first condition of the first characteristic.

16. The first medical device of claim **13** wherein the first communication retry strategy comprises:

detecting a first condition of a first characteristic of the patient;
 selecting a modified communication setting in light of the first condition of the first characteristic; and

retrying communication using the modified communication setting.

17. The first medical device of claim **13** wherein at least one of the first and second communication retry strategies comprises identifying a successful communication strategy and recording one or more parameters of the successful communication strategy for use in subsequent communication by the first medical device to the second medical device.

18. The first medical device of claim **13** wherein the second communication retry strategy comprises adjusting a communication setting in light of a first condition of a first characteristic of the patient, the first characteristic being a cyclic biological phenomenon of the patient.

19. A first medical device comprising a communication module for communicating with a second medical device and a controller operatively coupled to the communication module, the controller configured to optimize communication by:

identifying occurrence of a first cardiac R-wave; and
 attempting communication at a set time selected to be after a T-wave subsequent to the first cardiac R-wave and prior to a P-wave of a second cardiac R-wave that follows the first cardiac R-wave;

wherein the first medical device further comprises a plurality of electrodes for receiving cardiac electrical signals and sensing circuitry adapted to detect occurrence of the first cardiac R-wave.

20. The first medical device of claim **19** wherein the sensing circuitry is adapted to detect divergence of the received cardiac electrical signal from baseline, and the set time is selected to occur while the received cardiac electrical signal is near baseline.

* * * * *

专利名称(译)	具有时间优化的医疗设备系统中的通信		
公开(公告)号	US20180323865A1	公开(公告)日	2018-11-08
申请号	US16/033852	申请日	2018-07-12
[标]申请(专利权)人(译)	心脏起搏器股份公司		
申请(专利权)人(译)	心脏起搏器, INC.		
当前申请(专利权)人(译)	心脏起搏器, INC.		
[标]发明人	LUDWIG JACOB M KANE MICHAEL J KOOP BRENDAN E LINDER WILLIAM J MAILE KEITH R STAHMANN JEFFREY E		
发明人	LUDWIG, JACOB M. KANE, MICHAEL J. KOOP, BRENDAN E. LINDER, WILLIAM J. MAILE, KEITH R. STAHMANN, JEFFREY E.		
IPC分类号	H04B7/24 A61N1/372 A61N1/362 A61B5/00 H04L1/12 H04B13/00		
CPC分类号	A61N1/37288 A61N1/37217 A61N1/362 H04B7/24 A61B2560/0209 A61B5/0028 A61N1/37252 H04L1/12 H04B13/005 A61N1/3629		
优先权	62/134752 2015-03-18 US		
外部链接	Espacenet USPTO		

摘要(译)

用于管理植入式医疗设备之间的通信策略的系统和方法。方法包括相对于身体中的一种或多种识别的病症的时间优化。评估所选特征, 例如代表或链接到生物功能的信号, 以确定其可能对通信能力的影响, 并且可以开发一种或多种通信策略以优化体内通信。

