



(19) **United States**

(12) **Patent Application Publication**
Sadhu

(10) **Pub. No.: US 2017/0119319 A1**

(43) **Pub. Date: May 4, 2017**

(54) **USER WEARABLE PORTABLE COMMUNICATION DEVICE**

(52) **U.S. Cl.**

CPC *A61B 5/747* (2013.01); *A61B 5/02055* (2013.01); *A61B 5/0024* (2013.01); *A61B 5/0022* (2013.01); *A61B 5/0404* (2013.01); *A61B 5/0006* (2013.01); *A61B 5/0008* (2013.01); *A61B 5/1112* (2013.01); *A61B 5/7445* (2013.01); *A61B 5/681* (2013.01); *A61B 5/7475* (2013.01); *A61B 8/0866* (2013.01); *A61B 8/488* (2013.01); *H04N 7/147* (2013.01); *G01S 19/17* (2013.01); *G06F 19/3418* (2013.01); *G06F 1/3231* (2013.01); *F24F 11/0086* (2013.01); *A61B 5/02438* (2013.01)

(71) Applicant: **Rajendra Padma Sadhu**, Somerset, NJ (US)

(72) Inventor: **Rajendra Padma Sadhu**, Somerset, NJ (US)

(21) Appl. No.: **15/406,400**

(22) Filed: **Jan. 13, 2017**

Related U.S. Application Data

(63) Continuation of application No. 14/025,475, filed on Sep. 12, 2013, now Pat. No. 9,545,230, which is a continuation of application No. 13/105,925, filed on May 12, 2011, now Pat. No. 8,568,313, which is a continuation-in-part of application No. 12/722,554, filed on Mar. 12, 2010.

Publication Classification

(51) **Int. Cl.**

A61B 5/00 (2006.01)
A61B 5/0404 (2006.01)
A61B 5/11 (2006.01)
F24F 11/00 (2006.01)
H04N 7/14 (2006.01)
G01S 19/17 (2006.01)
G06F 19/00 (2006.01)
G06F 1/32 (2006.01)
A61B 5/0205 (2006.01)
A61B 8/08 (2006.01)

ABSTRACT

(57)

A user wearable portable communication device and a method for collecting and transmitting a plurality of physiological parameters to a remote monitoring center are disclosed. The portable communication device includes a provision for enabling the user to establish a video conference, a fall detection module in conjunction with an accelerometer recognizes a placement of the portable communication device, a home automation module for enabling the user to remotely operate multiple electronic devices, an acknowledgment acceptance module for receiving the acknowledgment, a physiological data collecting module communicatively coupled to a fetal Doppler module for monitoring and transmitting the physiological parameters associated with a child, multiple preprogrammed contact numbers for enabling the user to establish a communication, a subscriber identity module for enabling the user establish a communication and data transmission between the portable communication device and the remote monitoring center.

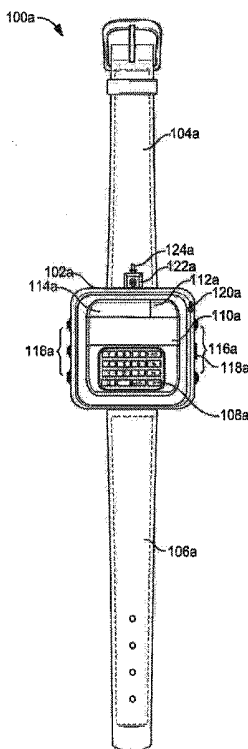

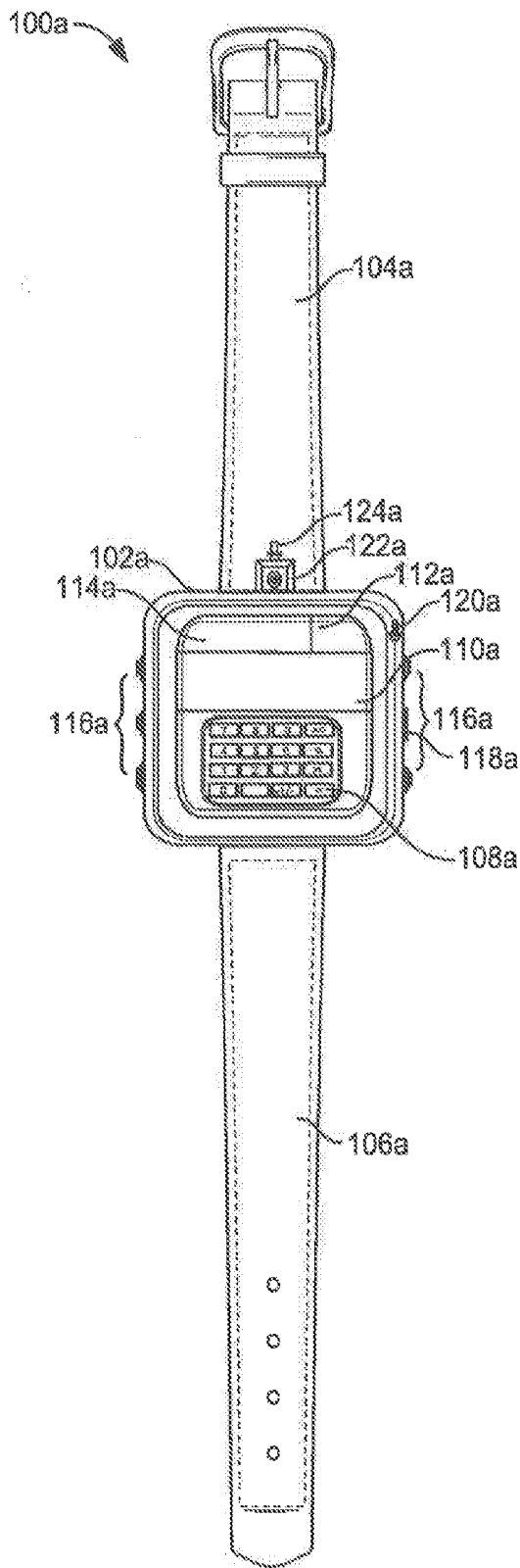

FIG. 1a

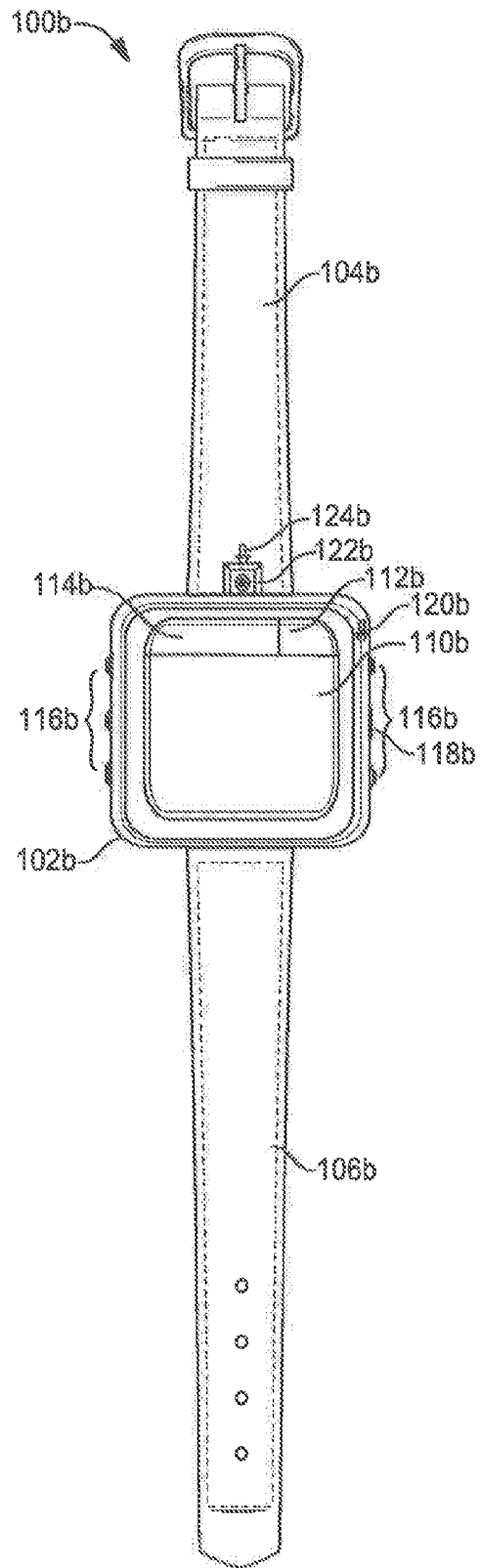

FIG. 1b

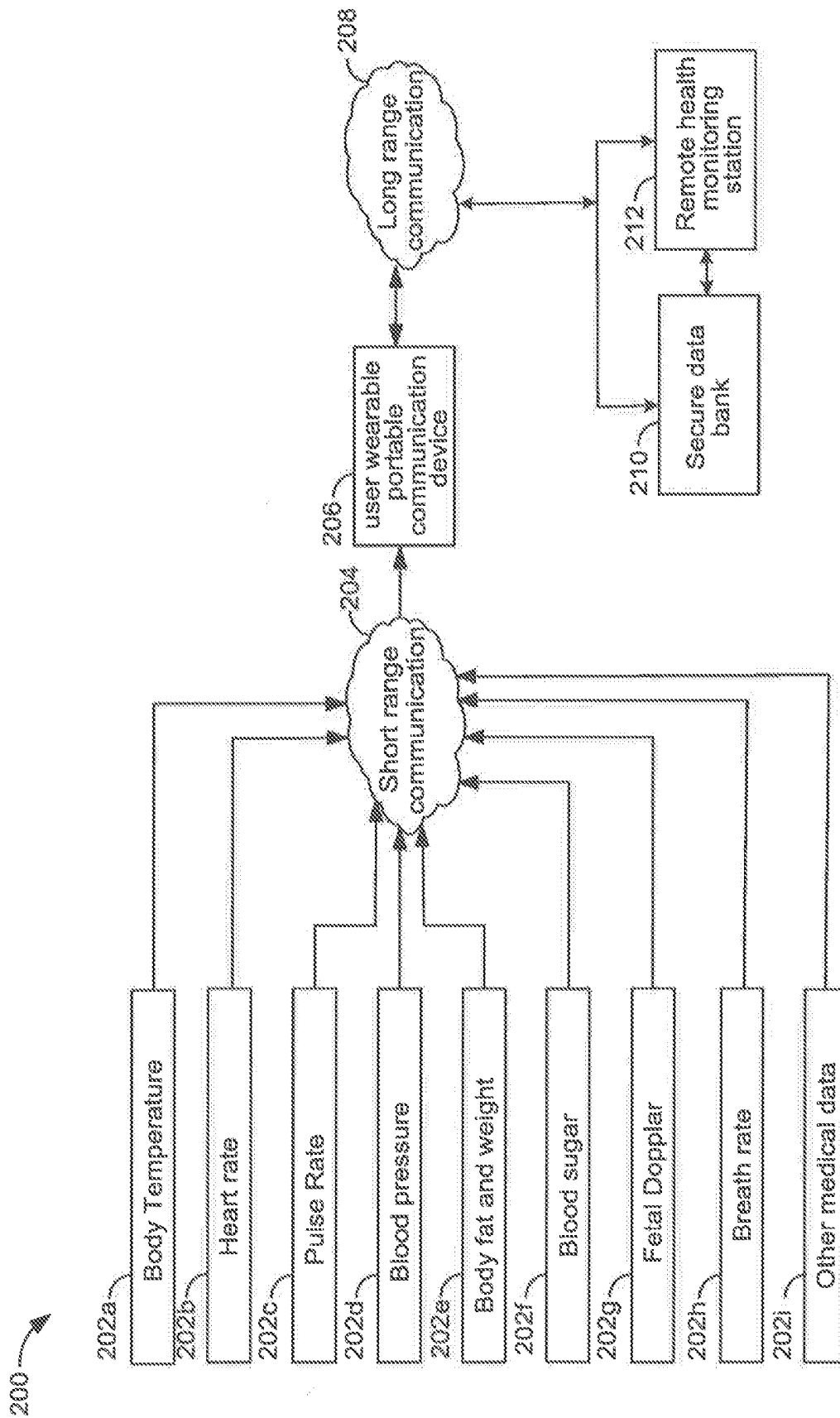

FIG. 2

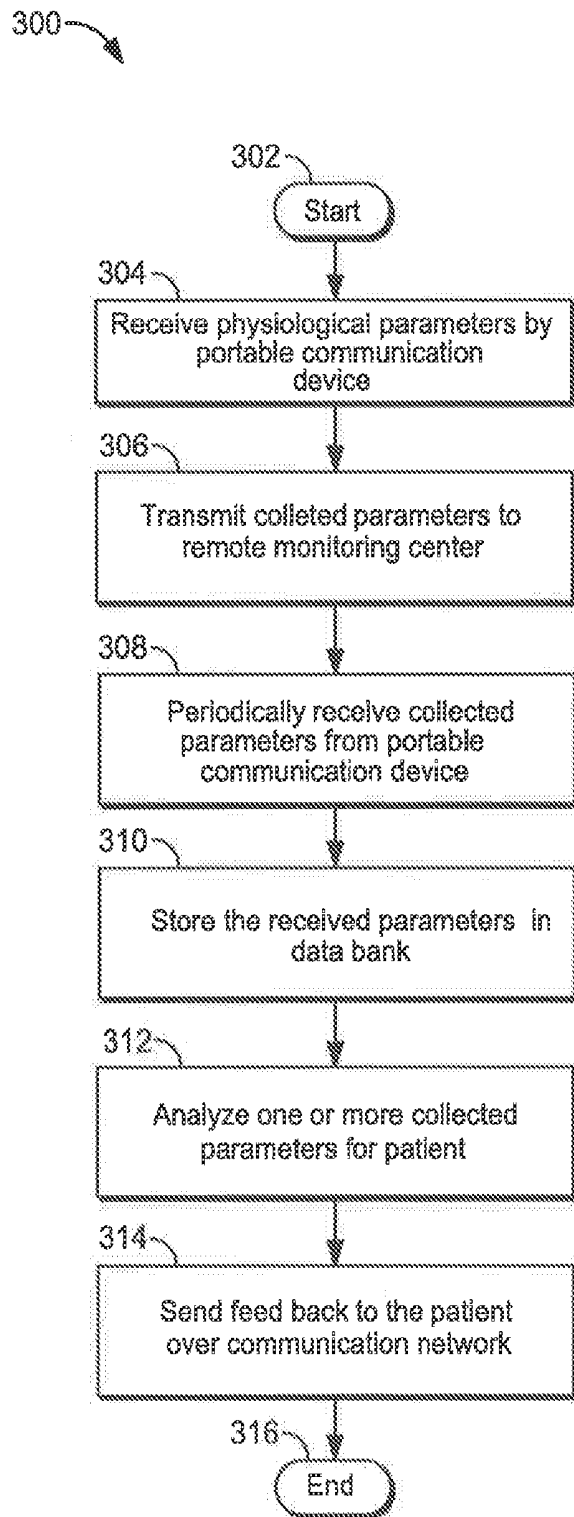

FIG.3

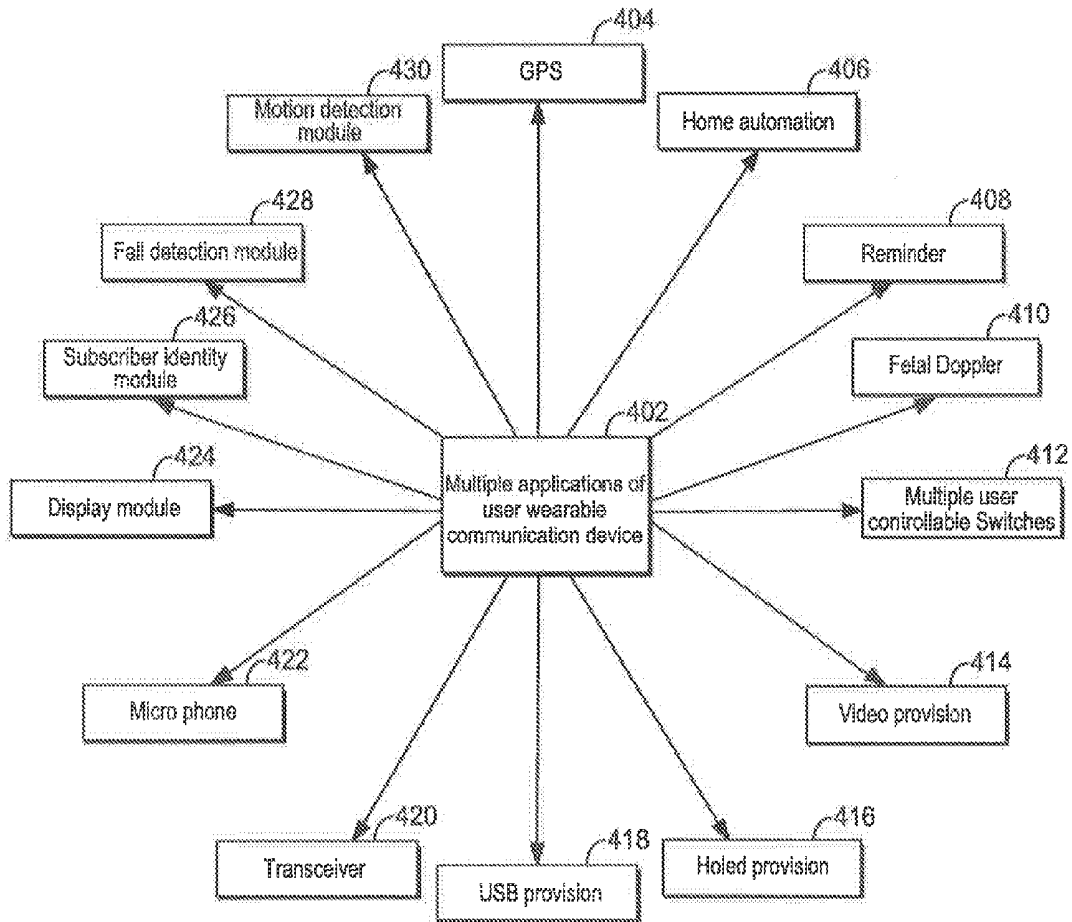

FIG.4

USER WEARABLE PORTABLE COMMUNICATION DEVICE

RELATED APPLICATIONS

[0001] This is a Continuation application of U.S. patent application Ser. No. 14/025,475, filed Sep. 12, 2013 which is a Continuation of U.S. patent application Ser. No. 13/105,925, filed May 12, 2011, that is now U.S. Pat. No. 8,568,313, which is a Continuation-In-Part of U.S. patent application Ser. No. 12/722,554, filed Mar. 12, 2010, the contents of each of which are hereby incorporated by reference in their entireties.

TECHNICAL FIELD OF THE INVENTION

[0002] The present invention generally relates to a user wearable portable communication device. More particularly the present invention is related to a user wearable portable communication device for collecting and transmitting physiological parameters to a remote monitoring center.

BACKGROUND

[0003] Generally, the number of users requiring the remote health care is increasing in the past few years. The remote health care systems use a variety of health care devices to continuously monitor the user in a non-invasive manner. But these types of health care devices are not portable and restricted to one geographical area.

[0004] Emergency health crises that require immediate attention have been a difficult problem to address regardless of the age of the person encountering a medical emergency situation. Conventionally, the panic button type devices interlink the user to the emergency response team via landline or mobile telephone. If the user is suddenly disabled during a sudden health crisis, such as in a heart attack or a serious fall situation, the panic-button type devices become useless. Furthermore, if the person is able to press the button the person should be within the effective wireless transmission distance to the device that dials the telephone to report the emergency. The panic button type devices are not effective for the users when the users are in unconscious state or rendered incapacitated by a fall or other medical condition. Furthermore no vital information on the user's status like heart rate, blood pressure, breath rate, body temperature, oxygen level and the like will be transmitted to the response team to provide further medical assistance. Consequently, it is difficult for the response team to diagnose and provide treatment to the user.

[0005] Typically, the health monitoring systems should have an adjustable emergency alert level throughout a day for different levels of activity. The capacity to determine the location of the person, who requires immediate medical assistance, should be more effective, accurate and relevant to provide proper medical assistance. The global positioning systems (GPS) determine the location of the user when signals from multiple GPS satellites are received by the system. The GPS system fails to determine the location of the user when signals are not received from more than one satellite due to shielding by buildings or geographic features or improper antenna orientation. The conventional GPS tracking systems comprises multiple integrated circuit chips. Consequently the multiple integrated circuit chips consume more power compared to the single integrated circuit chips with the combined capabilities of the individual integrated

circuit chips. Furthermore the conventional GPS receivers can determine the location of the user only when there is clear view of the sky within several feet of the GPS receiver's antenna.

[0006] Typically, many health care facilities perform the vital sign monitoring of the user only once in a week due to the time and money needed to perform these operations. If the user's vital signs are checked only once in a week, the declining health condition of the user is detected after the health condition is worsened. Furthermore this is eliminating the opportunity for early intervention. The user's physiological parameters such as pulse rate, heart beat rate, electrocardiogram (EKG), blood pressure, breathing rate, body temperature and the like should be measured and monitored continuously. Further the measured parameters and the location of the user should be transmitted to the central monitoring system to continuously monitor the physiological parameters of the user while simultaneously tracking the location of the user.

[0007] In light of the aforementioned limitations, there clearly exists a need for user wearable portable communication device for monitoring, receiving and analyzing the physiological parameters related to the user for providing remote health care services by communicating with a remote health care monitoring center through a communication network by receiving the location of the user through the communication network for providing emergency medical services.

SUMMARY OF THE INVENTION

[0008] The following presents a simplified summary of the disclosure in order to provide a basic understanding to the reader. This summary is not an extensive overview of the disclosure and it does not identify key/critical elements of the invention or delineate the scope of the invention. Its sole purpose is to present some concepts disclosed herein in a simplified form as a prelude to the more detailed description that is presented later.

[0009] In accordance with teachings of the present disclosure, a user wearable portable communication device and a method for collecting and transmitting a plurality of physiological parameters to a remote monitoring center are disclosed.

[0010] In accordance with teachings of the present disclosure, the present invention describes about a user wearable portable communication device for receiving a plurality of physiological parameters from a plurality of physiological data collecting devices.

[0011] Further purpose of the present invention is to transmit the plurality of physiological parameters from the user wearable portable communication device to a remote monitoring center for providing a remote health care services.

[0012] Another objective of the present invention is to enable a communication between an expectant and the remote monitoring center for monitoring and transmitting the physiological parameters associated with a child by utilizing a fetal Doppler module.

[0013] Still another objective of the present invention is to track a current location of a user by utilizing a global positioning system communication network.

[0014] Other objective of the present invention, the portable communication device facilitates the user to remotely operate a plurality of electronic devices by utilizing a home automation module.

[0015] Further objective of the present invention, the portable communication device receives an acknowledgment of a plurality of reminders for preventing the repetition of the alarms.

[0016] Still further objective of the present invention is to facilitate the user to establish a video conference with the multiple health care providers present over the remote monitoring center. Still another objective of the present invention is to provide a plurality of preprogrammed contact number for facilitating the communication between the portable communication device and the remote monitoring center through a plurality of user controllable switches.

[0017] Further objective of the present invention is to recognize a placement of the portable communication device by a fall detection module operating in conjunction with the accelerometer.

[0018] Still further objective of the present invention, the user wearable portable communication device utilizes a short range communication for collecting data from the plurality of physiological devices and utilizes a long range communication for transmitting the collected data to the remote monitoring center.

[0019] Another purpose of the present invention provide emergency medical attention to the user by continuously monitoring the plurality of physiological parameters.

[0020] A user wearable portable communication device and a method for collecting and transmitting a plurality of physiological parameters to a remote monitoring center are disclosed. According to a first aspect of the present invention, the user wearable portable communication device includes at least one provision for enabling the user to establish a video conference with the plurality of health care providers present over the remote monitoring center. The communication with the remote monitoring center enabled through a communication network includes at least one of a global system for mobile communications, a general packet radio service, a Wi-Fi network. The at least one provision for enabling the user to establish a video conference with the plurality of health care providers includes at least one of a webcam, a video camera and the like.

[0021] According to the first aspect of the present invention, the user wearable portable communication device includes at least one fall detection module in conjunction with an accelerometer recognizes a placement of the portable communication device.

[0022] According to the first aspect of the present invention, the user wearable portable communication device includes at least one home automation module for enabling the user to remotely operate a plurality of electronic devices.

[0023] According to the first aspect of the present invention, the user wearable portable communication device includes at least one acknowledgment acceptance module for receiving the acknowledgment corresponding to a plurality of medical reminders.

[0024] According to the first aspect of the present invention, the user wearable portable communication device includes at least one physiological data collecting module communicatively coupled to at least one fetal Doppler module for monitoring and transmitting the physiological parameters associated with a child to the plurality of health

care providers present over the remote monitoring center. The at least one physiological data collecting module receives the physiological parameters over a short range communication network employing a set of communication protocols from a plurality of plurality of physiological data collecting devices. The set of communication protocols include at least one of a transmission control protocol/internet protocol, a hypertext transfer protocol and the like. The short range communication network includes at least one of a Bluetooth network, a Zigbee network and the like.

[0025] According to the first aspect of the present invention, the user wearable portable communication device includes a plurality of preprogrammed contact numbers for enabling the user to establish a communication with the plurality of health care providers.

[0026] According to the first aspect of the present invention, the user wearable portable communication device includes at least one subscriber identity module for enabling the user perform at least one of a step of establishing a communication between the portable communication device and the remote monitoring center, a step of data transmission between the portable communication device and the remote monitoring center and the like.

[0027] According to the first aspect of the present invention, the user wearable portable communication device further includes a location tracking module for tracking a current location of the user through at least one of an assisted global positioning system, a global positioning system and the like.

[0028] According to the first aspect of the present invention, the user wearable portable communication device further includes a universal serial bus provision for receiving the physiological parameters from the plurality of physiological data collecting devices.

[0029] According to a second aspect of the present invention, a method adapted for collecting and transmitting a plurality of physiological parameters from a user wearable portable communication device to a remote monitoring center is disclosed. The method adapted for collecting and transmitting a plurality of physiological parameters from a user wearable portable communication device to a remote monitoring center includes facilitating a video conference between a user and a plurality of health care providers present over the remote monitoring center by using at least one provision.

[0030] According to the second aspect of the present invention, the method adapted for collecting and transmitting a plurality of physiological parameters from a user wearable portable communication device to a remote monitoring center includes detecting a placement of the portable communication device by using at least one fall detection module in conjunction with an accelerometer.

[0031] According to the second aspect of the present invention, the method adapted for collecting and transmitting a plurality of physiological parameters from a user wearable portable communication device to a remote monitoring center includes remotely operating a plurality of electronic devices by using at least one home automation module.

[0032] According to the second aspect of the present invention, the method adapted for collecting and transmitting a plurality of physiological parameters from a user wearable portable communication device to a remote monitoring center includes receiving the acknowledgment of the

plurality of medical reminders by using at least one acknowledgment acceptance module.

[0033] According to the second aspect of the present invention, the method adapted for collecting and transmitting a plurality of physiological parameters from a user wearable portable communication device to a remote monitoring center includes monitoring and transmitting the physiological parameters associated with a child to the plurality of health care providers present over the remote monitoring center by utilizing at least one physiological data collecting module communicatively coupled to at least one fetal Doppler module.

[0034] According to the second aspect of the present invention, the method adapted for collecting and transmitting a plurality of physiological parameters from a user wearable portable communication device to a remote monitoring center includes enabling the user to establish a communication with the plurality of health care providers by utilizing a plurality of preprogrammed contact numbers. The plurality of physiological parameters from the plurality of physiological data collecting devices of the user collected through a short range communication. The plurality of preprogrammed contact numbers enables the user to establish a communication with the plurality of health care providers present over the remote monitoring center.

[0035] According to the second aspect of the present invention, the method adapted for collecting and transmitting a plurality of physiological parameters from a user wearable portable communication device to a remote monitoring center includes establishing a communication between the portable communication device and the remote monitoring center through at least one subscriber identity module for enabling at least one of a voice based communication, a data transmission and the like.

[0036] According to the second aspect of the present invention, the method adapted for collecting and transmitting a plurality of physiological parameters from a user wearable portable communication device to a remote monitoring center further includes employing a set of communication protocols for enabling a communication between the plurality of physiological data collecting devices and the portable communication device.

BRIEF DESCRIPTION OF THE FIGURES

[0037] Other objects and advantages of the present invention will become apparent to those skilled in the art upon reading the following detailed description of the preferred embodiments, in conjunction with the accompanying drawings, wherein like reference numerals have been used to designate like elements, and wherein:

[0038] FIG. 1a is a diagram depicting a user wearable portable communication device with a keypad.

[0039] FIG. 1b is a diagram depicting a user wearable portable communication device without a keypad.

[0040] FIG. 2 is a diagram depicting an overview of a communication between a user wearable portable communication device and a remote monitoring center.

[0041] FIG. 3 is a flow diagram illustrating a method of communication between a user wearable portable communication device and a remote health care monitoring center.

[0042] FIG. 4 is a diagram depicting an overview of multiple applications associated with a user wearable portable communication device.

DETAILED DESCRIPTION OF THE EMBODIMENTS

[0043] It is to be understood that the present disclosure is not limited in its application to the details of construction and the arrangement of components set forth in the following description or illustrated in the drawings. The present disclosure is capable of other embodiments and of being practiced or of being carried out in various ways. Also, it is to be understood that the phraseology and terminology used herein is for the purpose of description and should not be regarded as limiting.

[0044] The use of “including”, “comprising” or “having” and variations thereof herein is meant to encompass the items listed thereafter and equivalents thereof as well as additional items. The terms “a” and “an” herein do not denote a limitation of quantity, but rather denote the presence of at least one of the referenced item. Further, the use of terms “first”, “second”, and “third”, and the like, herein do not denote any order, quantity, or importance, but rather are used to distinguish one element from another.

[0045] Exemplary embodiments of the present invention are directed towards a user wearable portable communication device and a method for collecting and transmitting a plurality of physiological parameters to a remote monitoring center are disclosed. According to the first aspect of a present invention, the user wearable portable communication device includes at least one provision for enabling the user to establish a video conference with the plurality of health care providers present over the remote monitoring center. The communication with the remote monitoring center enabled through a communication network includes at least one of a global system for mobile communications, a general packet radio service, a Wi-Fi network. The at least one provision for enabling the user to establish a video conference with the plurality of health care providers includes at least one of a webcam, a video camera and the like.

[0046] According to the first aspect of the present invention, the user wearable portable communication device includes at least one fall detection module in conjunction with an accelerometer recognizes a placement of the portable communication device.

[0047] According to the first aspect of the present invention, the user wearable portable communication device includes at least one home automation module for enabling the user to remotely operate a plurality of electronic devices.

[0048] According to the first aspect of the present invention, the user wearable portable communication device includes at least one acknowledgment acceptance module for receiving the acknowledgment corresponding to a plurality of medical reminders.

[0049] According to the first aspect of the present invention, the user wearable portable communication device includes at least one physiological data collecting module communicatively coupled to at least one fetal Doppler module for monitoring and transmitting the physiological parameters associated with a child to the plurality of health care providers present over the remote monitoring center. The at least one physiological data collecting module receives the physiological parameters over a short range communication network employing a set of communication protocols from a plurality of plurality of physiological data collecting devices. The set of communication protocols include at least one of a transmission control protocol/

internet protocol, a hypertext transfer protocol and the like. The short range communication network includes at least one of a Bluetooth network, a Zigbee network and the like.

[0050] According to the first aspect of the present invention, the user wearable portable communication device includes a plurality of preprogrammed contact numbers for enabling the user to establish a communication with the plurality of health care providers.

[0051] According to the first aspect of the present invention, the user wearable portable communication device includes at least one subscriber identity module for enabling the user perform at least one of a step of establishing a communication between the portable communication device and the remote monitoring center, a step of data transmission between the portable communication device and the remote monitoring center and the like.

[0052] According to the first aspect of the present invention, the user wearable portable communication device further includes a location tracking module for tracking a current location of the user through at least one of an assisted global positioning system, a global positioning system and the like.

[0053] According to the first aspect of the present invention, the user wearable portable communication device further includes a universal serial bus provision for receiving the physiological parameters from the plurality of physiological data collecting devices.

[0054] According to a second aspect of the present invention, a method adapted for collecting and transmitting a plurality of physiological parameters from a user wearable portable communication device to a remote monitoring center is disclosed. The method adapted for collecting and transmitting a plurality of physiological parameters from a user wearable portable communication device to a remote monitoring center includes facilitating a video conference between a user and a plurality of health care providers present over the remote monitoring center by using at least one provision.

[0055] According to the second aspect of the present invention, the method adapted for collecting and transmitting a plurality of physiological parameters from a user wearable portable communication device to a remote monitoring center includes detecting a placement of the portable communication device by using at least one fall detection module in conjunction with an accelerometer.

[0056] According to the second aspect of the present invention, the method adapted for collecting and transmitting a plurality of physiological parameters from a user wearable portable communication device to a remote monitoring center includes remotely operating a plurality of electronic devices by using at least one home automation module.

[0057] According to the second aspect of the present invention, the method adapted for collecting and transmitting a plurality of physiological parameters from a user wearable portable communication device to a remote monitoring center includes receiving the acknowledgment of the plurality of medical reminders by using at least one acknowledgment acceptance module.

[0058] According to the second aspect of the present invention, the method adapted for collecting and transmitting a plurality of physiological parameters from a user wearable portable communication device to a remote monitoring center includes monitoring and transmitting the physi-

ological parameters associated with a child to the plurality of health care providers present over the remote monitoring center by utilizing at least one physiological data collecting module communicatively coupled to at least one fetal Doppler module.

[0059] According to the second aspect of the present invention, the method adapted for collecting and transmitting a plurality of physiological parameters from a user wearable portable communication device to a remote monitoring center includes enabling the user to establish a communication with the plurality of health care providers by utilizing a plurality of preprogrammed contact numbers. The plurality of physiological parameters from the plurality of physiological data collecting devices of the user collected through a short range communication. The plurality of preprogrammed contact numbers enables the user to establish a communication with the plurality of health care providers present over the remote monitoring center.

[0060] According to the second aspect of the present invention, the method adapted for collecting and transmitting a plurality of physiological parameters from a user wearable portable communication device to a remote monitoring center includes establishing a communication between the portable communication device and the remote monitoring center through at least one subscriber identity module for enabling at least one of a voice based communication, a data transmission and the like.

[0061] According to the second aspect of the present invention, the method adapted for collecting and transmitting a plurality of physiological parameters from a user wearable portable communication device to a remote monitoring center further includes employing a set of communication protocols for enabling a communication between the plurality of physiological data collecting devices and the portable communication device.

[0062] Referring to FIG. 1a is a diagram 100a depicting a user wearable portable communication device with keypad. According to an exemplary embodiment of the present invention, the user wearable portable communication device includes a main housing 102a, a first strap 104a, a second strap 106a, a keypad 108a, a physiological parameter display 110a, a time display 112a, a date display 114a, multiple user controllable switches 116a, a universal serial bus provision 118a, a microphone 120a, a provision for video conference 122a and a holed provision 124a to use the wearable portable communication device as a pendant.

[0063] In accordance with an exemplary embodiment of the present invention, the main housing 102a of the user wearable portable communication device includes a keypad 108a for facilitating the user to establish a communication by dialing the plurality of numbers present on the keypad. The communication is enabled by a subscriber identity module (SIM) present in the portable communication device. The microphone 120a positioned on the main housing 102a of the portable communication device facilitates the voice based communication. The main housing 102a further includes physiological parameter display 110a for displaying the multiple physiological parameters of the user received from the multiple physiological data collecting devices. The multiple physiological parameters of the user includes a heart rate, a pulse rate, a body temperature, a body fat and weight, a blood sugar, a breath rate, other medical data and the like. The multiple physiological data collecting

devices includes a chest belt, a blood pressure monitor, a body fat and weight scale, a blood sugar monitor and the like.

[0064] According to an exemplary embodiment of the present invention, the first strap **104a** is attached to the first end of the main housing **102a** and the second strap **106a** is attached to the second end of the main housing **102a**. The main housing **102a** includes the time display **112a** for displaying the time and the date display **114a** for displaying the date. The display module simultaneously displays the measured physiological parameters, time and date. The display module is an organic light emitting diode (OLED) made with organic material for displaying the data according to a non limiting exemplary embodiment of the present invention. The main housing **102a** includes a universal serial bus provision **118a** for receiving the physiological parameters from the multiple physiological data collecting devices. Further the physiological parameters from the multiple physiological data collecting devices are transmitted to the portable communication device through a short range communication network. The short range communication network preferably includes but not limited to a Bluetooth network, a Zigbee network and the like.

[0065] In accordance with an exemplary embodiment of the present invention, the received physiological parameters are further transmitted from the portable communication device to the remote monitoring center through a long range communication network. The long range communication network preferably includes but not limited to a global system for mobile communications (GSM), a general packet radio service (GPRS), a Wi-Fi network and the like. The global system for mobile communications (GSM) further includes dual band and quad band for supporting multiple frequencies of data transmission. The portable communication device further utilizes a global positioning system (GPS) for tracking a current location of the user. By tracking the current location of the user, the multiple health care providers present over remote monitoring center provides an emergency medical assistance to the user.

[0066] According to an exemplary embodiment of the present invention, the main housing **102a** further includes the multiple user controllable switches **116a** for enabling the user to establish a voice based communicative interaction with the multiple health care providers present over the remote monitoring center. The multiple user controllable switches **116a** enable the user to establish the communication by utilizing multiple preprogrammed contact numbers stored in the portable communication device along with the microphone **120a**. A holed provision **124a** fastened to the main housing allows the user to wear the portable communication device as a pendent. The provision **122a** for video enables the users to establish a video conference with the multiple health care providers present over the remote monitoring center. The provision **122a** for video includes multiple embodiments preferably including but not limited to a webcam, a video camera, a digital camera and the like. Further the portable communication device enables the user remotely operate the multiple electronic devices by utilizing a home automation module.

[0067] Referring to FIG. 1b is a diagram **100b** depicting a user wearable portable communication device without a keypad. The portable communication device includes a main housing **102b**, a first strap **104b**, a second strap **106b**, a physiological parameter display **110b**, a time display **112b**,

a date display **114b**, multiple user controllable switches **116b**, a universal serial bus provision **118b**, a microphone **120b**, a provision for video conference **122b** and a holed provision **124b** to use the wearable portable communication device serving as a pendent.

[0068] In accordance with an exemplary embodiment of the present invention, the main housing **102b** includes the physiological parameter display **110b** for displaying the multiple physiological parameters received from the multiple physiological data collecting devices. The multiple physiological parameters of the user includes a heart rate, a pulse rate, a body temperature, a body fat and weight, a blood sugar, a breath rate, other medical data and the like. The multiple physiological data collecting devices includes a chest belt, a blood pressure monitor, a body fat and weight scale, a blood sugar monitor and the like. The time display **112b** displays the time and the date display **114b** displays the date.

[0069] According to an exemplary embodiment of the present invention, the multiple user controllable switches **116b** enables the user to establish a voice based communication with the multiple health care providers present over the remote monitoring center by utilizing multiple preprogrammed contact numbers. The user is facilitated with the video conference by utilizing a provision **122b** and the holed provision **124b** positioned above the provision **122b** for video enables the user to wear the portable communication device as a pendent in accordance with an exemplary embodiment of the present invention.

[0070] In accordance with an exemplary embodiment of the present invention, the first strap **104b** is attached to the first end of the main housing **102b** and the second strap **106b** is attached to the second end of the main housing **102b**. The first strap **104b** and the second strap **106b** enable the user to tie the portable communication device to the wrist of the user. The multiple user controllable switches **116b** enable the user to establish a voice based communicative interaction with the multiple health care providers present over the remote monitoring center. The multiple user controllable switches **116b** enable the user to establish the communication by utilizing multiple preprogrammed contact numbers stored in the portable communication device and the universal serial bus provision **118b** of the portable communication device receives the multiple physiological parameters from the multiple physiological data collecting devices.

[0071] Referring to FIG. 2 is a diagram **200** depicting an overview of a communication between a user wearable portable communication device and a remote monitoring center. According to an exemplary embodiment of the present invention, the overview of the communication between the user wearable portable communication device and the remote monitoring center depicts multiple physiological parameters preferably including but not limited to a body temperature **202a**, a heart rate **202b**, a pulse rate **202c**, a blood pressure **202d**, a body fat and weight **202e**, a blood sugar **202f**, a fetal Doppler **202g**, a breath rate **202h** and other medical data **202i** received from the multiple physiological data collecting devices of the user, a short range communication network **204**, a user wearable portable communication device **206**, a long range communication network **208**, a secure data bank **210** and a remote monitoring center **212**.

[0072] According to an exemplary embodiment of the present invention, the multiple physiological parameters

preferably including but not limited to the body temperature **202a**, the heart rate **202b**, the pulse rate **202c**, the blood pressure **202d**, the body fat and weight **202e**, the blood sugar **202f**, the fetal Doppler **202g**, the breath rate **202h** and the other medical data **202i** is received from the multiple physiological data collecting devices including a chest belt, a blood pressure monitor, a body fat and weight scale, a blood sugar monitor and the like. The multiple physiological parameters are received by the portable communication device by utilizing a short range communication network **204**. The short range communication network preferably includes but not limited to a Bluetooth network, a Zigbee network and the like. The portable communication device receives the multiple physiological parameters from the multiple physiological data collecting devices during pre-defined regular intervals. In emergency situations the portable communication device facilitates the user to establish a communication with multiple health care providers present over the remote monitoring center by dialing the multiple preprogrammed contact number stored in the portable communication device by utilizing the multiple user controllable switches. Further the user is also facilitated with a provision to establish a video conference with the multiple health care providers present over the remote monitoring center. The portable communication device communicatively coupled with the fetal Doppler for monitoring the physiological parameters of the child and transfers the monitored parameters to the remote monitoring center.

[0073] In accordance with an exemplary embodiment of the present invention, after receiving the multiple physiological parameters from the multiple physiological data collecting devices by utilizing the short range communication network, the portable communication device further transmits the collected physiological parameters to the remote monitoring station **212** through the long range communication network **208** for storing the multiple physiological parameters in the secure data bank **210**. The long range communication network preferably includes but not limited to a global system for mobile communications (GSM), a general packet radio service (GPRS), a Wi-Fi network and the like. The portable communication device **206** further utilizes the global positioning system (GSM) for tracking the current location of the user.

[0074] According to an exemplary embodiment of the present invention, the multiple health care providers present over the remote monitoring center **212** receives the data transmitted by the portable communication device **206**, stores the data in the secure databank, analyzes the received data and transmits the feedback to the portable communication device of the user. Depending upon the data received from the portable communication device **206**, the multiple health care providers present over the remote monitoring center provides the assistance to the user.

[0075] Referring to FIG. 3 is a flow diagram **300** illustrating a method of communication between a user wearable portable communication device and a remote monitoring center. According to an exemplary embodiment of the present invention, the method of communication between the user wearable portable communication device and the remote monitoring center starts at step **302**.

[0076] From step **302**, the flow diagram **300** continues with step **304** which describes about a portable communication device receiving multiple physiological parameters from the multiple physiological data collecting devices. The

multiple physiological parameters preferably includes but not limited to a heart rate, a pulse rate, a body temperature, a body fat and weight, a blood sugar, a breath rate, other medical data and the like. The multiple physiological data collecting devices includes a chest belt, a blood pressure monitor, a body fat and weight scale, a blood sugar monitor and the like.

[0077] The portable communication device receives the multiple physiological parameters from the multiple physiological data collecting devices by utilizing a short range communication network. The short range communication network preferably includes but not limited to a Bluetooth network, a Zigbee network and the like.

[0078] From step **304**, the flow diagram **300** continues with step **306** which describes about transmitting the multiple collected physiological parameters to a remote monitoring center through a long range communication network. The long range communication network preferably includes but not limited to a global system for mobile communications (GSM), a general packet radio service (GPRS), a Wi-Fi network and the like. The portable communication device further utilizes the global positioning system (GSM) for tracking the current location of the user.

[0079] From step **306**, the flow diagram **300** continues with step **308** which describes about the remote monitoring center periodically receiving the collected physiological parameters from the portable communication device. The remote monitoring center receives the multiple physiological parameters during regular intervals for continuously monitoring the user.

[0080] From step **308**, the flow diagram **300** continues with step **310** which describes about storing the received multiple physiological parameters in the secure data bank. The data bank stored the multiple physiological parameters for maintaining a history of the medical records associated with the user while providing treatment to the user.

[0081] From step **310**, the flow diagram **300** continues with step **312** which describes about analyzing the stored physiological parameters of the user. Analyzing the multiple physiological parameters by comparing the multiple physiological parameters stored in the secured databank enables the multiple health care providers to provide an effective medical assistance.

[0082] From step **312**, the flow diagram **300** continues with step **314** which describes about transmitting a feed back to the portable communication device. The multiple health care providers present over the remote monitoring center transmits the feedback including medical assistance to the user based on the analyzed physiological parameters.

[0083] Finally, the flow diagram **300** depicting the method of communication between the user wearable portable communication device and the remote monitoring center ends at step **316**.

[0084] Referring to FIG. 4 is a diagram **400** illustrating an overview of multiple applications associated with a user wearable portable communication device. According to an exemplary embodiment of the present invention, the overview of the multiple applications associated with the user wearable portable communication device **402** depicts a global positioning system (GPS) **404**, an home automation **406**, multiple reminders **408**, a fetal Doppler **410**, multiple user controllable switches **412**, a provision **414** for enabling a video conference, a holed provision **416**, a universal serial bus provision (USB) **418**, a transceiver **420**, a micro phone

422, a display module **424**, a subscriber identity module (SIM) **426**, a fall detection module **428**, a motion detection module **430**.

[0085] According to an exemplary embodiment of the present invention, the global positioning system (GPS) **404** in conjunction with a location tracking module of the portable communication device is used to track the current location of the user for providing emergency medical assistance. The home automation module **406** of the portable communication device is used to remotely operate multiple electronic devices located at home. The multiple electronic devices preferably includes but not limited to an air conditioner, a cooler, a fridge, a bulb, a fan, an oven and the like. The multiple reminders **408** enable the user to take the medication at proper time. The acknowledgement acceptance of the multiple reminders prevents the repetition of the alarms. The fetal Doppler **410** communicatively coupled with the portable communication device enables the user monitor the physiological parameters of the child and transmits the measured parameters to the remote monitoring center.

[0086] In accordance with an exemplary embodiment of the present invention, the multiple user controllable switches **412** facilitates the user to establish a voice based communicative interaction with the multiple health care providers present over the remote monitoring center. The user controllable switches **412** along with the microphone **422** are used for establishing the voice based communication and also the multiple preprogrammed contact numbers are utilized for communicating with the multiple health

[0087] Attorney Docket No: **587798** care providers present over the remote monitoring center. The provision **414** enables the user to establish a video conference with the multiple health care providers present over the remote monitoring center.

[0088] According to a non limiting exemplary embodiment of the present invention, the holed provision **416** facilitates the user to wear the portable communication device as a pendant and the universal serial bus provision **418** of the portable communication device receives the multiple physiological parameters from the multiple physiological data collecting devices. The transceiver **420** enables the transmission and reception of the data between the portable communication device and the remote monitoring center. The display **424** module of the portable communication device displays the multiple physiological parameters of the user, time and date. Further the subscriber identity module (SIM) **426** facilitates the user to communicate with the multiple health care providers and also to transmit the data to the remote monitoring center after receiving from the multiple physiological data collecting devices of the user.

[0089] In accordance with an exemplary embodiment of the present invention, the fall detecting module in conjunction with the accelerometer recognizes the placement of the portable communication device and the motion detecting module **430** identifies the movement of the portable communication device for reducing the power consumption.

[0090] While specific embodiments of the invention have been shown and described in detail to illustrate the inventive principles, it will be understood that the invention may be embodied otherwise without departing from such principles.

What is claimed is:

1. A user wearable portable communication device, comprising:
 - a main housing;
 - first and second straps attached to opposing ends of the main housing, to secure the main housing to a wrist;
 - a transceiver in the main housing and configured to transmit and receive data; and
 - a display module affixed in the front of the main housing and having an organic light emitting diode (OLED) made with at least one organic material for displaying the data.
2. The portable communication device of claim 1, further comprising a keypad responsive to user input to establish communication with the transceiver.
3. The portable communication device of claim 1, further comprising at least one camera and a microphone configured to establish video conferencing as the data.
4. The portable communication device of claim 3, the camera comprising at least one of a webcam and a video camera.
5. The portable communication device of claim 4, the video conferencing being with a plurality of health care providers.
6. The portable communication device of claim 1, further comprising at least one controllable switch responsive to user input to establish voice communications, as the data, with multiple health care providers.
7. The portable communication device of claim 1, further comprising a motion detecting module configured to identify movement of the portable communication device and reduce the power consumption.
8. The portable communication device of claim 1, further comprising a location tracking module configured to track current location of the portable communication device through at least one of an assisted global positioning system and a global positioning system.
9. The portable communication device of claim 1, the transceiver utilizing communication protocols comprising at least one of: a transmission control protocol/internet protocol, and a hypertext transfer protocol.
10. The portable communication device of claim 1, the transceiver implementing a short range communication network comprising at least one of: a Bluetooth network, and a Zigbee network.
11. The portable communication device of claim 1, the data comprising physiological parameters received from a plurality of physiological data collecting devices, the physiological parameters selected from the group including pulse rate, heart beat rate, electrocardiogram (EKG), blood pressure, breathing rate, and body temperature.
12. The portable communication device of claim 11, further comprising a universal serial bus configured to receive the physiological parameters from the plurality of physiological data collecting devices.
13. The portable communication device of claim 1, the transceiver facilitating communication with a remote monitoring center through a communication network selected from the group including a global system for mobile communications, a general packet radio service, and a Wi-Fi network.
14. The portable communication device of claim 1, further comprising a home automation module configured to remotely operate multiple electronic devices.

15. The portable communication device of claim 14, the multiple electronic devices selected from the group including an air conditioner, a cooler, a fridge, a bulb, a fan, and an oven.

16. A method for collecting, displaying, and transmitting physiological parameters, comprising:

receiving, within a user wearable portable communication device, physiological parameters from a plurality of physiological data collecting devices using a short range communication network selected from the group including a Bluetooth network and a Zigbee network; displaying at least one of the physiological parameters on a display of the user wearable portable communication device;

detecting, using at least one accelerometer of the user wearable portable communication device, placement of the portable communication device;

remotely operating a plurality of electronic devices from the user wearable portable communication device; and communicating with a remote monitoring center through a communication network using at least one of a global system for mobile communications, a general packet radio service, and a Wi-Fi network.

17. A user wearable portable communication device, comprising:

a main housing;

first and second straps attached to opposing ends of the main housing, to secure the main housing to a wrist;

a transceiver in the main housing and configured to transmit and receive data;

a display module affixed in the front of the main housing and having an organic light emitting diode (OLED) made with at least one organic material for displaying the data;

a home automation module configured to remotely operate multiple electronic devices selected from the group including an air conditioner, a cooler, a fridge, a bulb, a fan, and an oven;

at least one controllable switch responsive to user input to establish voice communications as the data; and

a location tracking module configured to track current location of the portable communication device through at least one of an assisted global positioning system and a global positioning system.

* * * * *

专利名称(译)	用户可穿戴便携式通信设备		
公开(公告)号	US20170119319A1	公开(公告)日	2017-05-04
申请号	US15/406400	申请日	2017-01-13
[标]申请(专利权)人(译)	圣人RAJENDRA PADMA		
申请(专利权)人(译)	圣者, RAJENDRA PADMA		
当前申请(专利权)人(译)	圣者, RAJENDRA PADMA		
[标]发明人	SADHU RAJENDRA PADMA		
发明人	SADHU, RAJENDRA PADMA		
IPC分类号	A61B5/00 A61B5/0404 A61B5/11 F24F11/00 H04N7/14 G01S19/17 G06F19/00 G06F1/32 A61B5/0205 A61B8/08		
CPC分类号	A61B5/747 A61B5/1117 A61B5/0024 A61B5/0022 A61B5/0404 A61B5/0006 A61B5/0008 A61B5/1112 A61B5/7445 A61B5/681 A61B5/7475 A61B8/0866 A61B8/488 H04N7/147 G01S19/17 G06F19/3418 G06F1/3231 F24F11/0086 A61B5/02438 A61B5/021 A61B5/0816 A61B2562/227 A61B2560/0209 A61B2562/0219 A61B5/02055 A61B5/7465 F24F11/30 G06F1/163 G08B21/0446 G08B21/0453 G16H40/67 A61B5/002 A61B5/0077 A61B5/01 A61B5/04087 A61B5/14532 A61B5/4872 A61B5/686		
外部链接	Espacenet	USPTO	

摘要(译)

公开了一种用户可携带便携式通信装置和用于收集和发送多个生理参数到远程监控中心的方法。便携式通信设备包括用于使得用户能够建立视频会议的设备,与加速度计结合的跌落检测模块识别便携式通信设备的放置,用于使得用户远程操作多个电子设备的家庭自动化模块,一个用于接收确认的确认接收模块,通信地耦合到胎儿多普勒模块的生理数据收集模块,用于监视和发送与子级相关联的生理参数,用于使得用户能够建立通信的多个预编程联系人号码;用户识别模块,使得用户能够在便携式通信设备和远程监控中心之间建立通信和数据传输。

