



US 20150216434A1

(19) **United States**

(12) **Patent Application Publication**
Ghosh et al.

(10) **Pub. No.: US 2015/0216434 A1**

(43) **Pub. Date: Aug. 6, 2015**

(54) **ASSESSING INTRA-CARDIAC ACTIVATION PATTERNS**

(71) Applicant: **Medtronic, Inc.**, Minneapolis, MN (US)

(72) Inventors: **Subham Ghosh**, Circle Pines, MN (US);
Jeffrey M. Gillberg, Coon Rapids, MN (US);
Robert W. Stadler, Shoreview, MN (US)

(21) Appl. No.: **14/635,498**

(22) Filed: **Mar. 2, 2015**

Related U.S. Application Data

(63) Continuation of application No. 13/462,480, filed on May 2, 2012, now Pat. No. 8,972,228.

(60) Provisional application No. 61/482,053, filed on May 3, 2011.

Publication Classification

(51) **Int. Cl.**
A61B 5/04 (2006.01)
A61B 5/00 (2006.01)
A61B 5/0402 (2006.01)
(52) **U.S. Cl.**
CPC *A61B 5/0402* (2013.01); *A61B 5/0402* (2013.01); *A61B 5/742* (2013.01)

(57) **ABSTRACT**

Techniques for evaluating cardiac electrical dyssynchrony are described. In some examples, an activation time is determined for each of a plurality of torso-surface potential signals. The dispersion or sequence of these activation times may be analyzed or presented to provide variety of indications of the electrical dyssynchrony of the heart of the patient. In some examples, the locations of the electrodes of the set of electrodes, and thus the locations at which the torso-surface potential signals were sensed, may be projected on the surface of a model torso that includes a model heart. The inverse problem of electrocardiography may be solved to determine electrical activation times for regions of the model heart based on the torso-surface potential signals sensed from the patient.

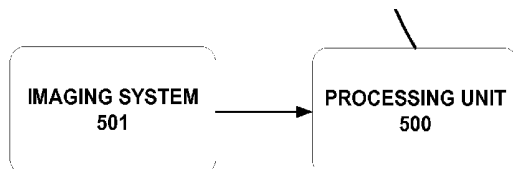
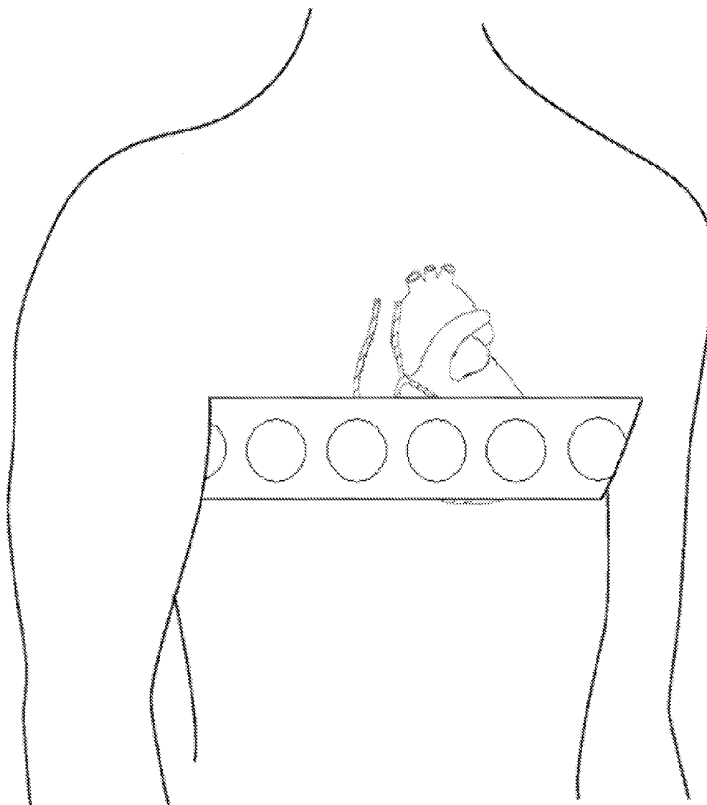

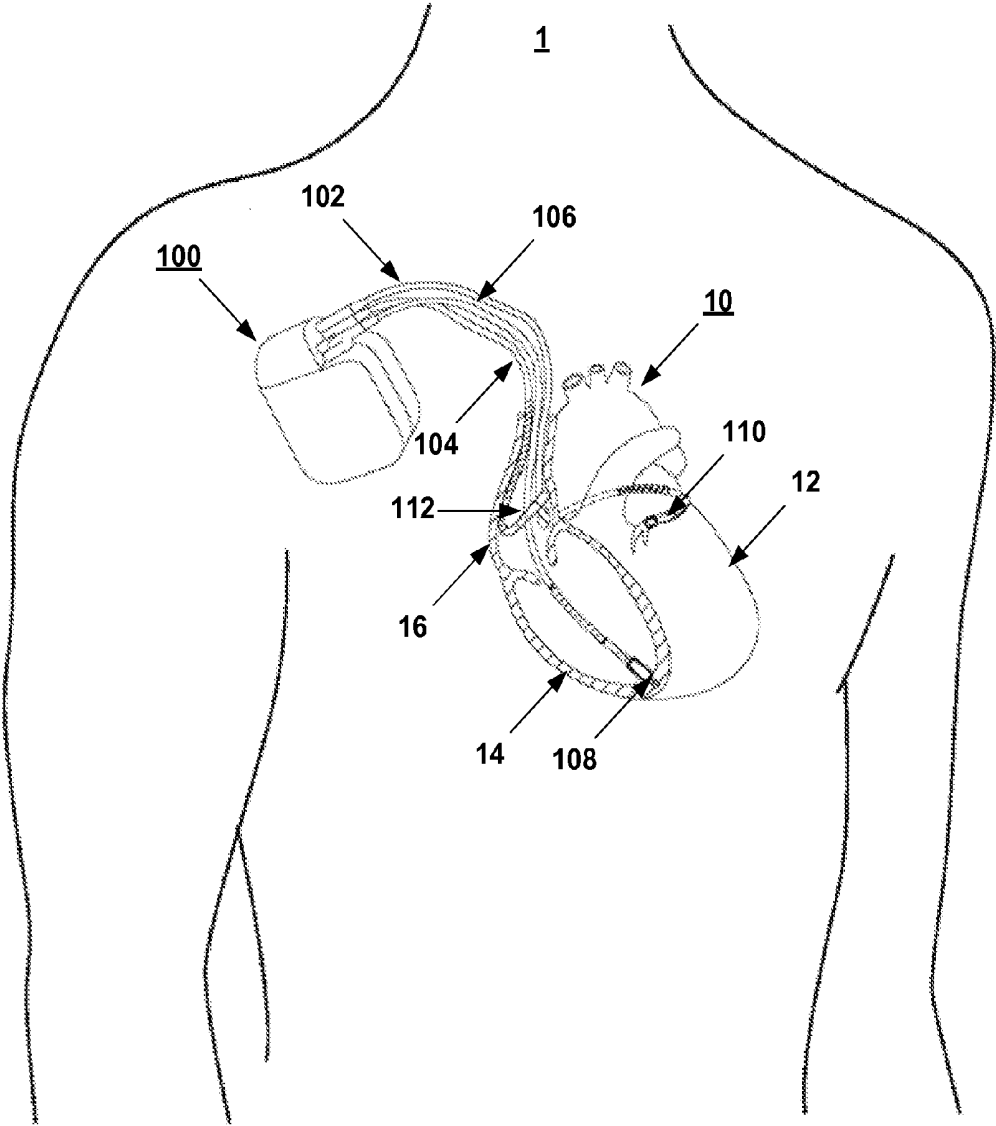

FIG. 1

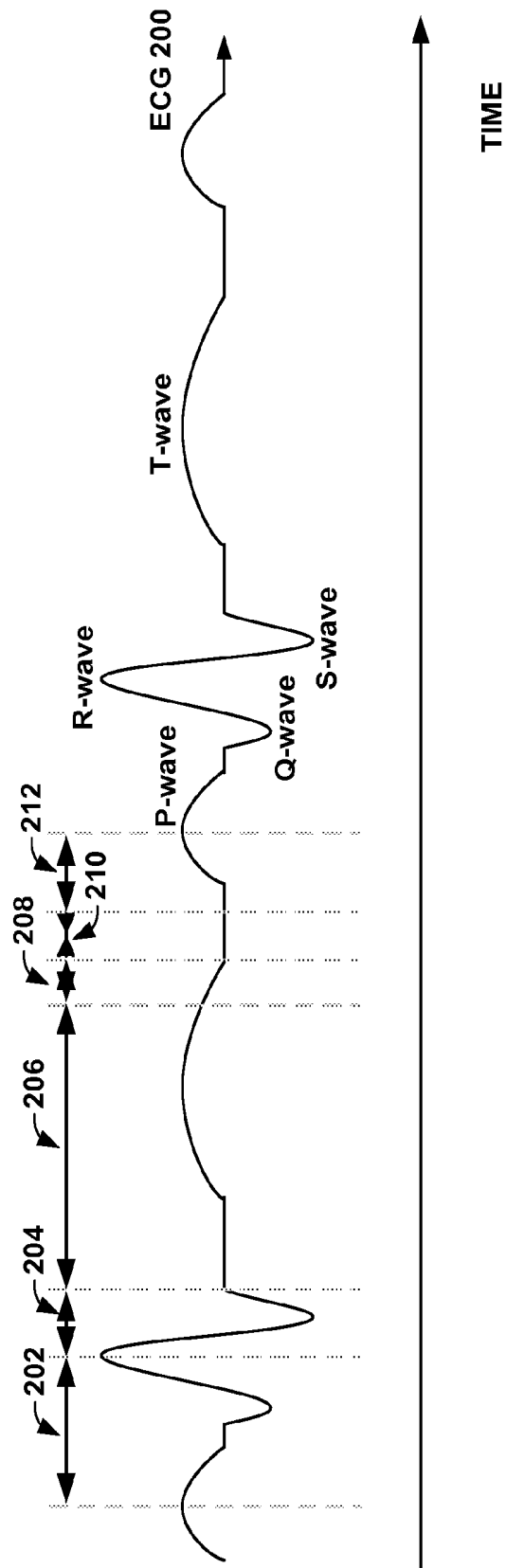

FIG. 2

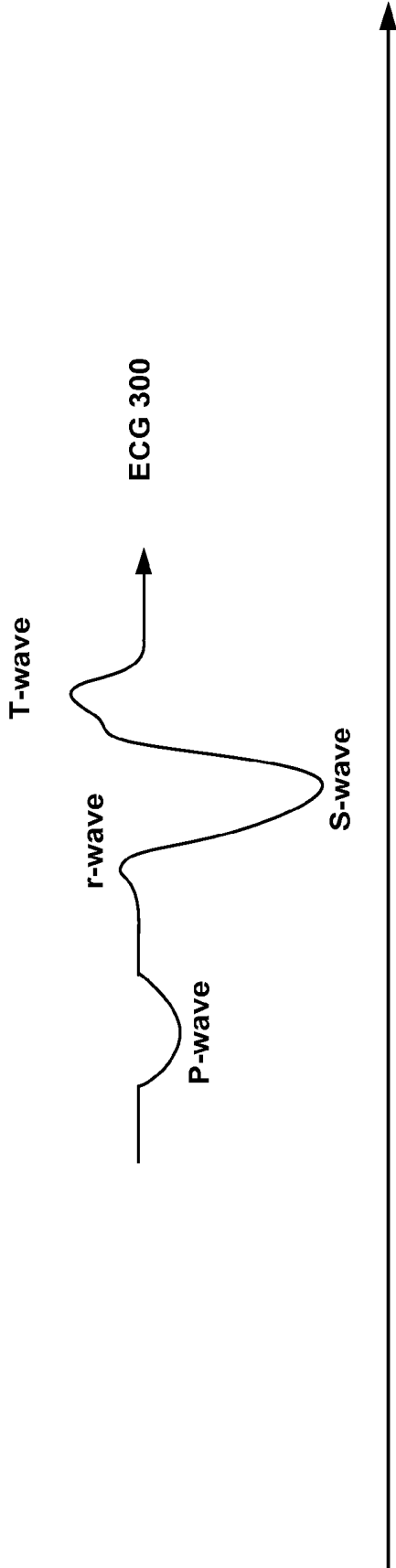

FIG. 3

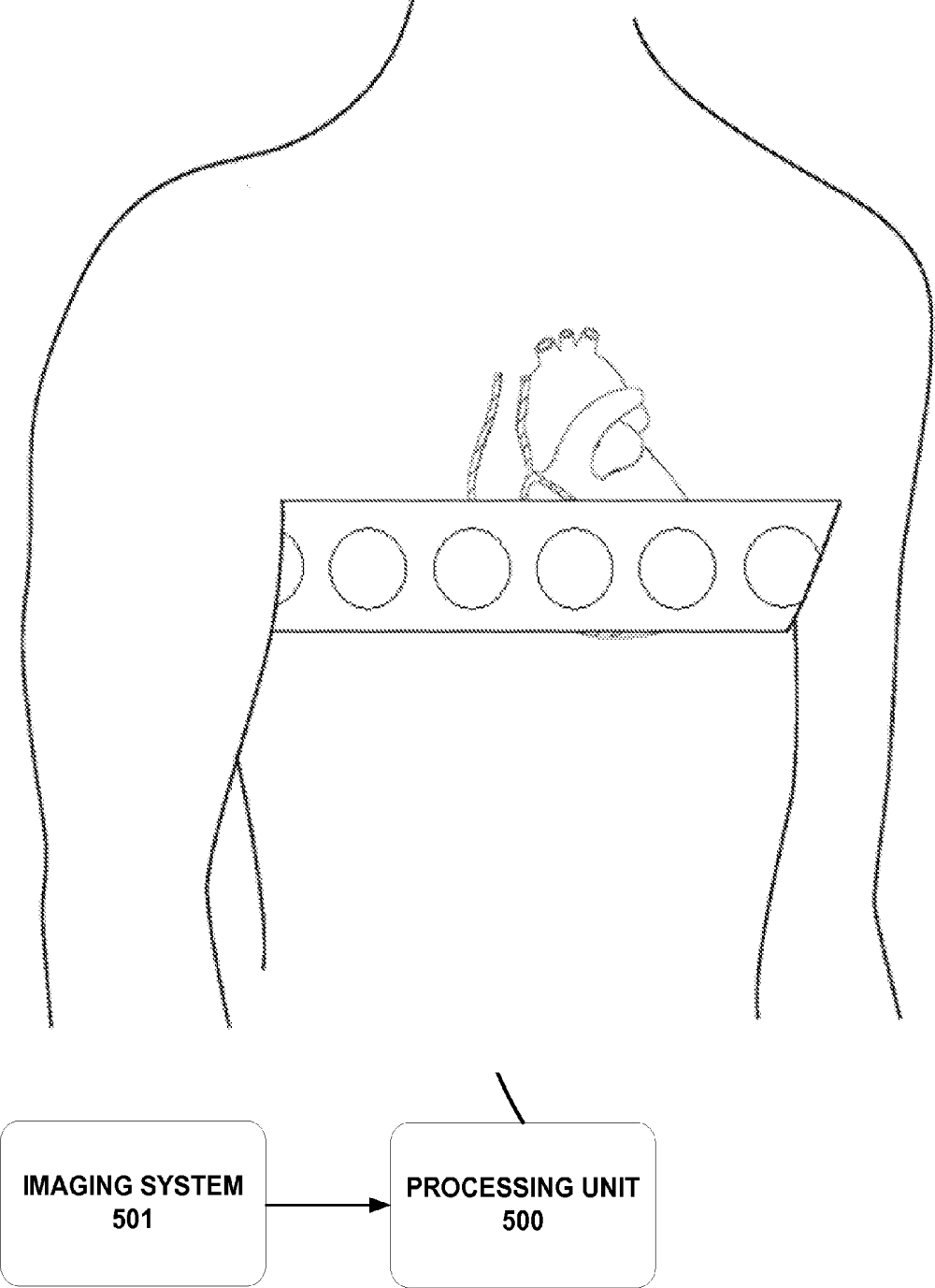

FIG. 4A

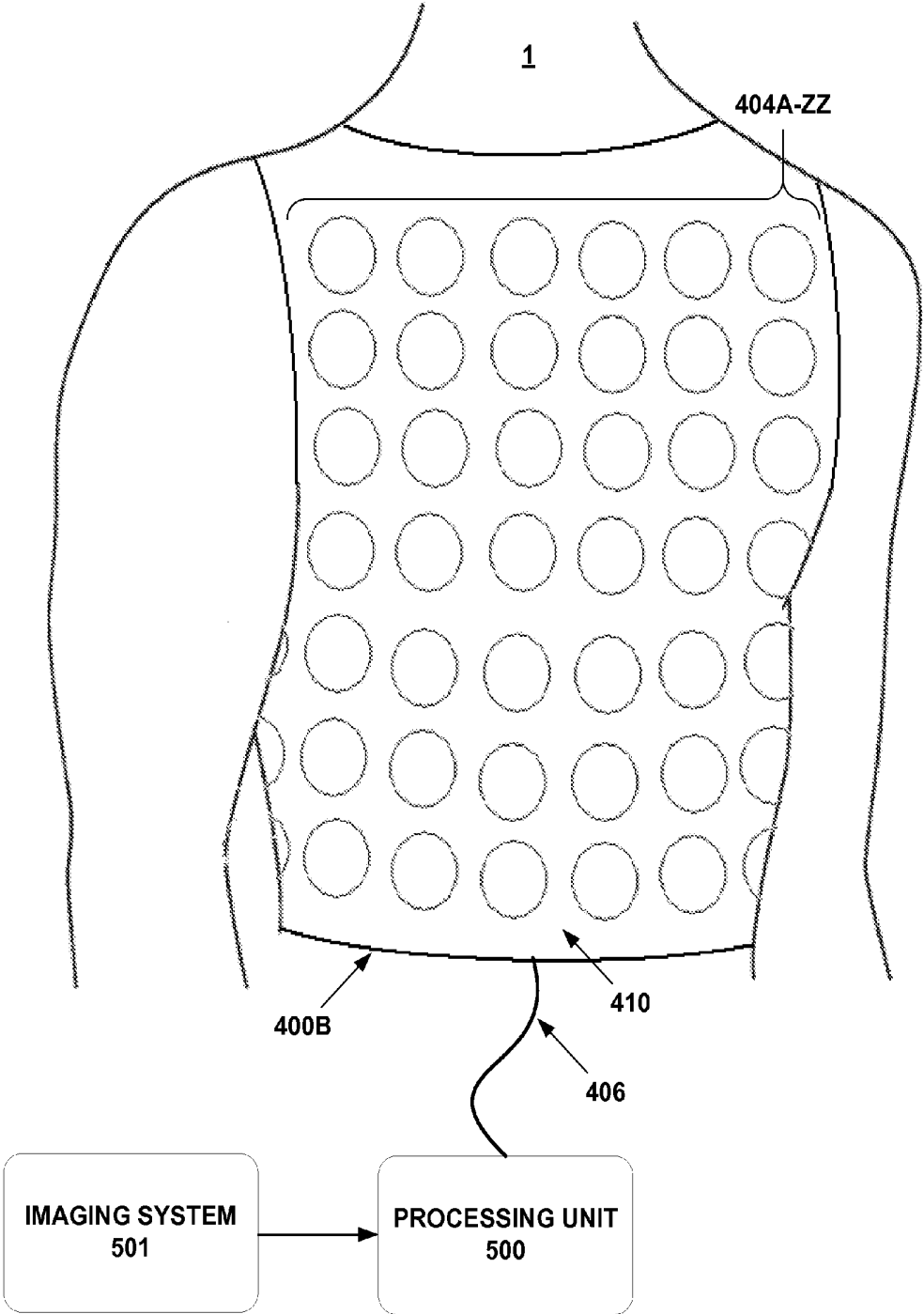

FIG. 4B

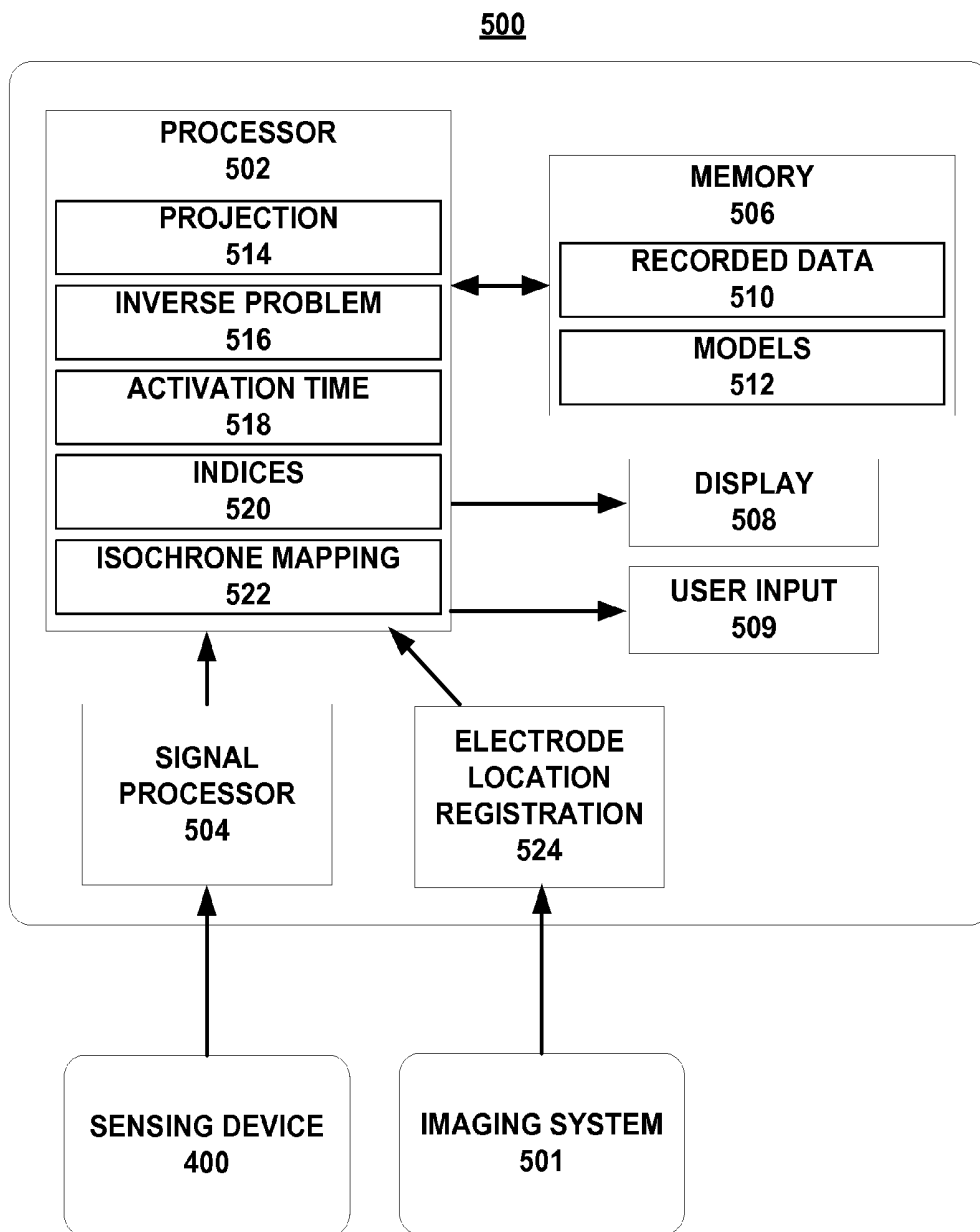

FIG. 5

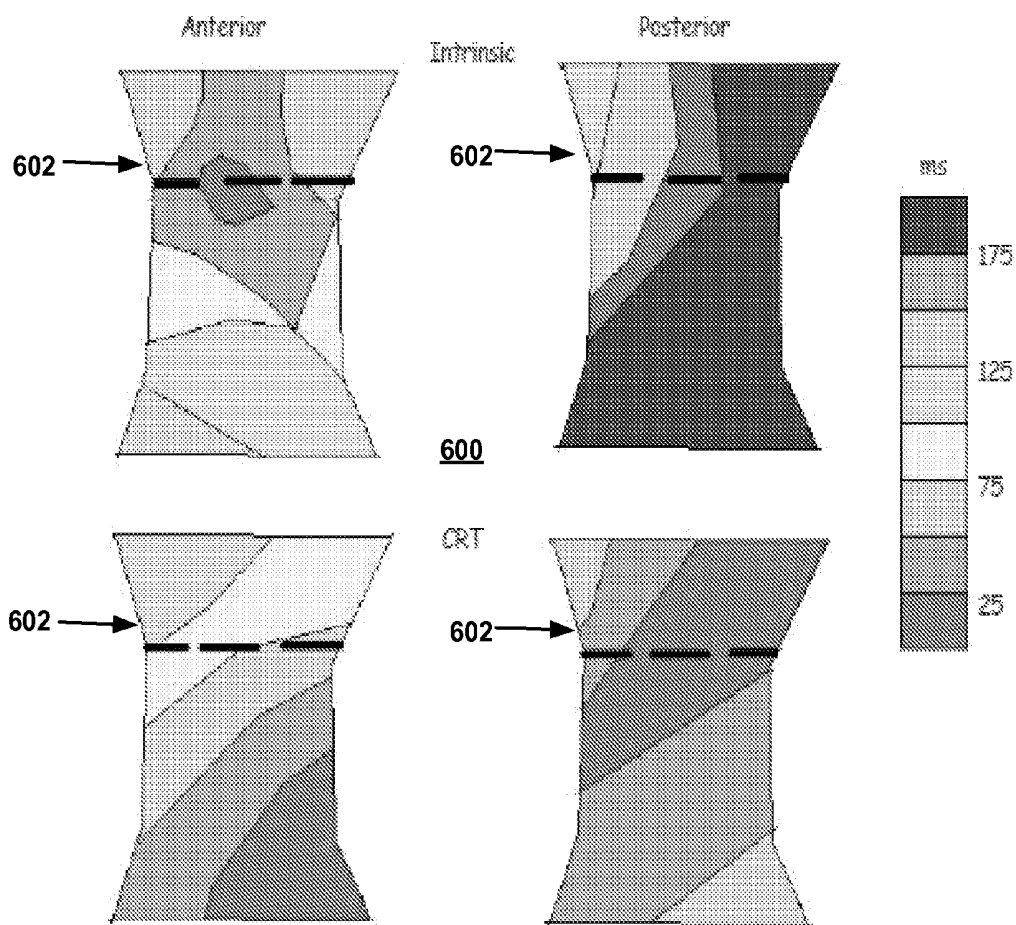

FIG. 6

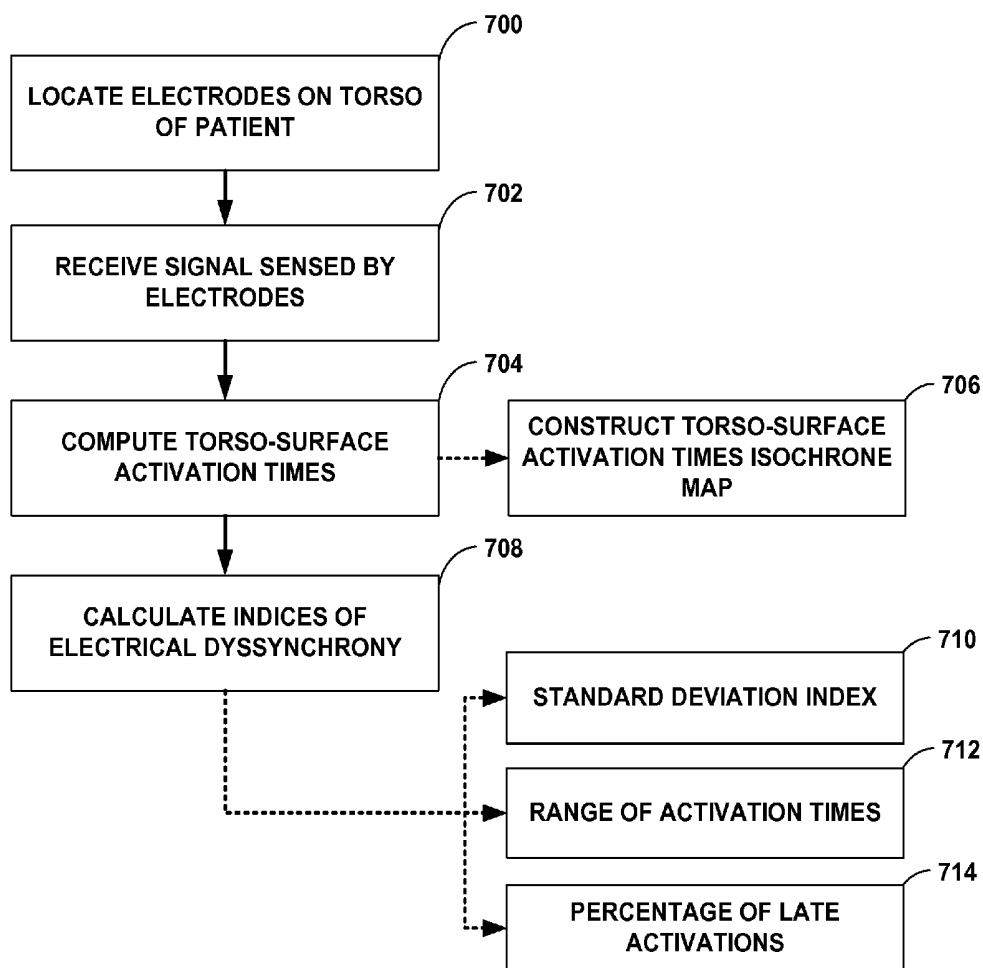

FIG. 7

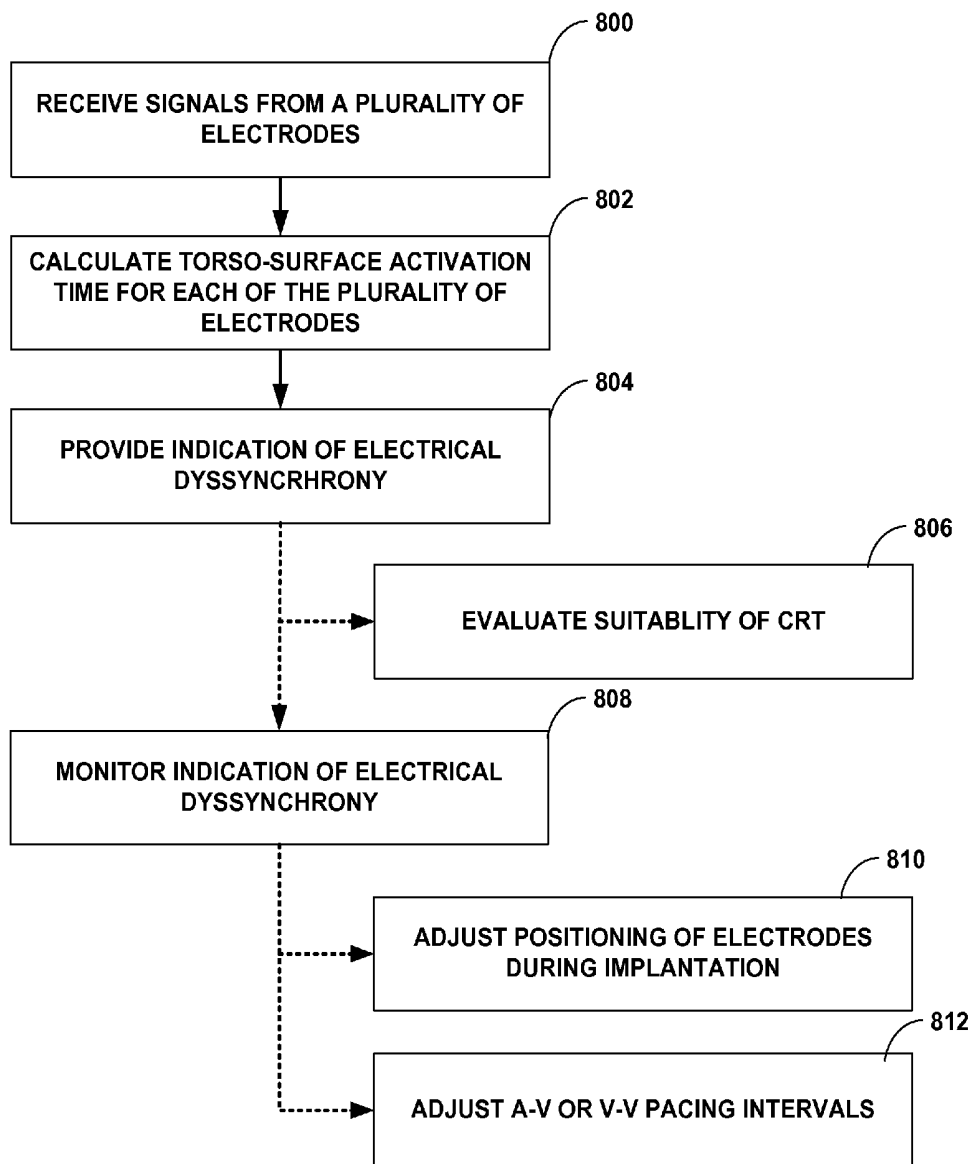

FIG. 8

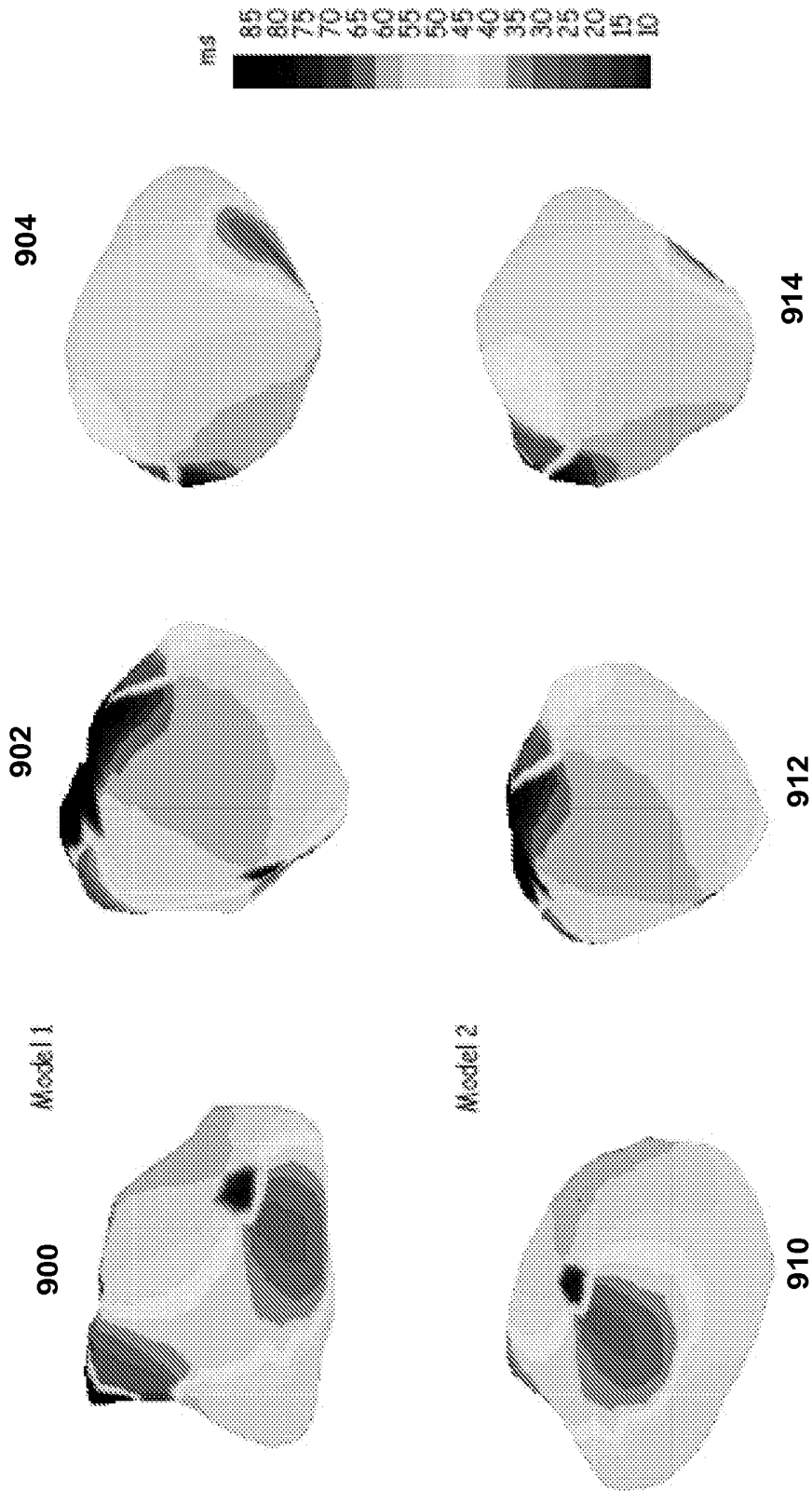

FIG. 9

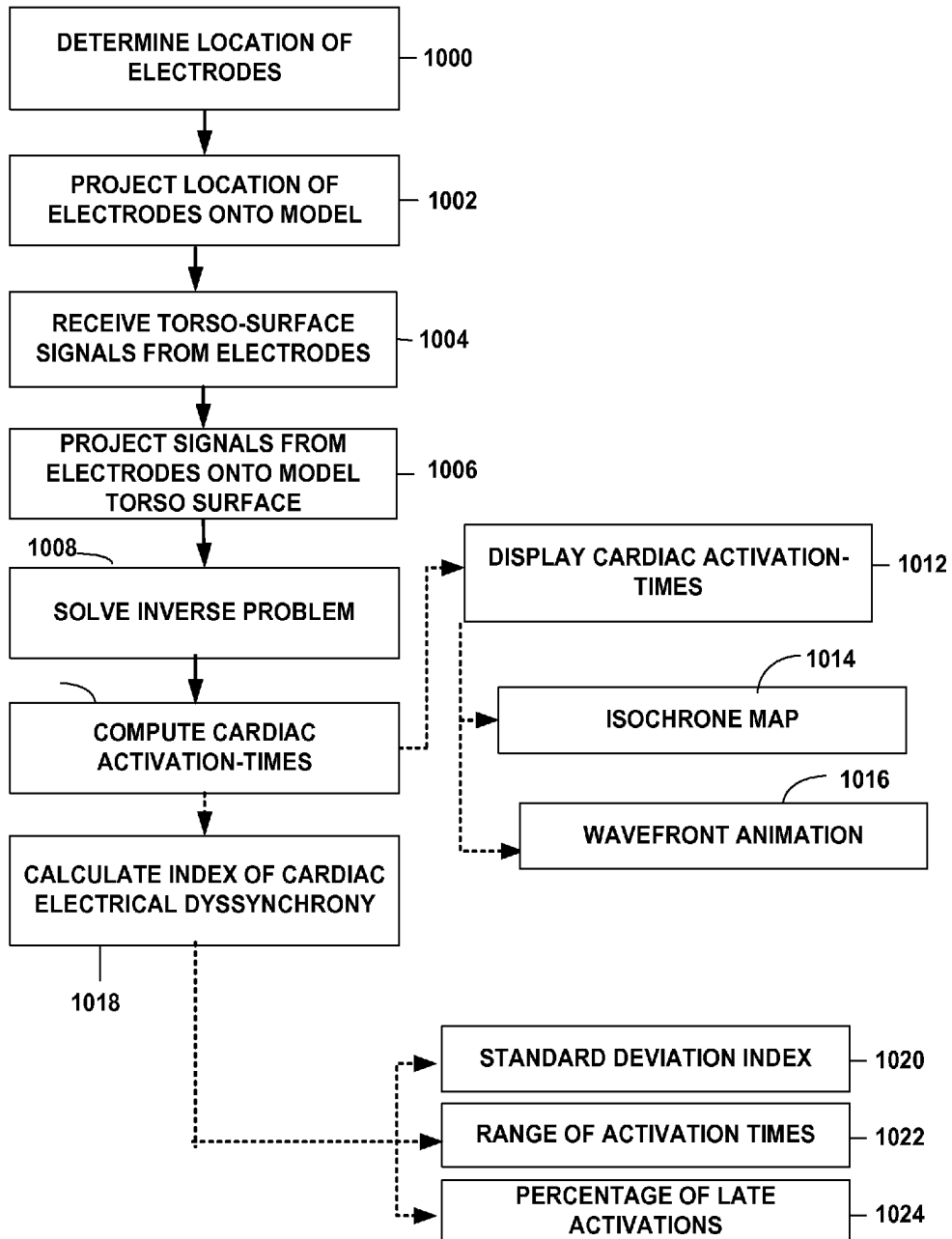

FIG. 10

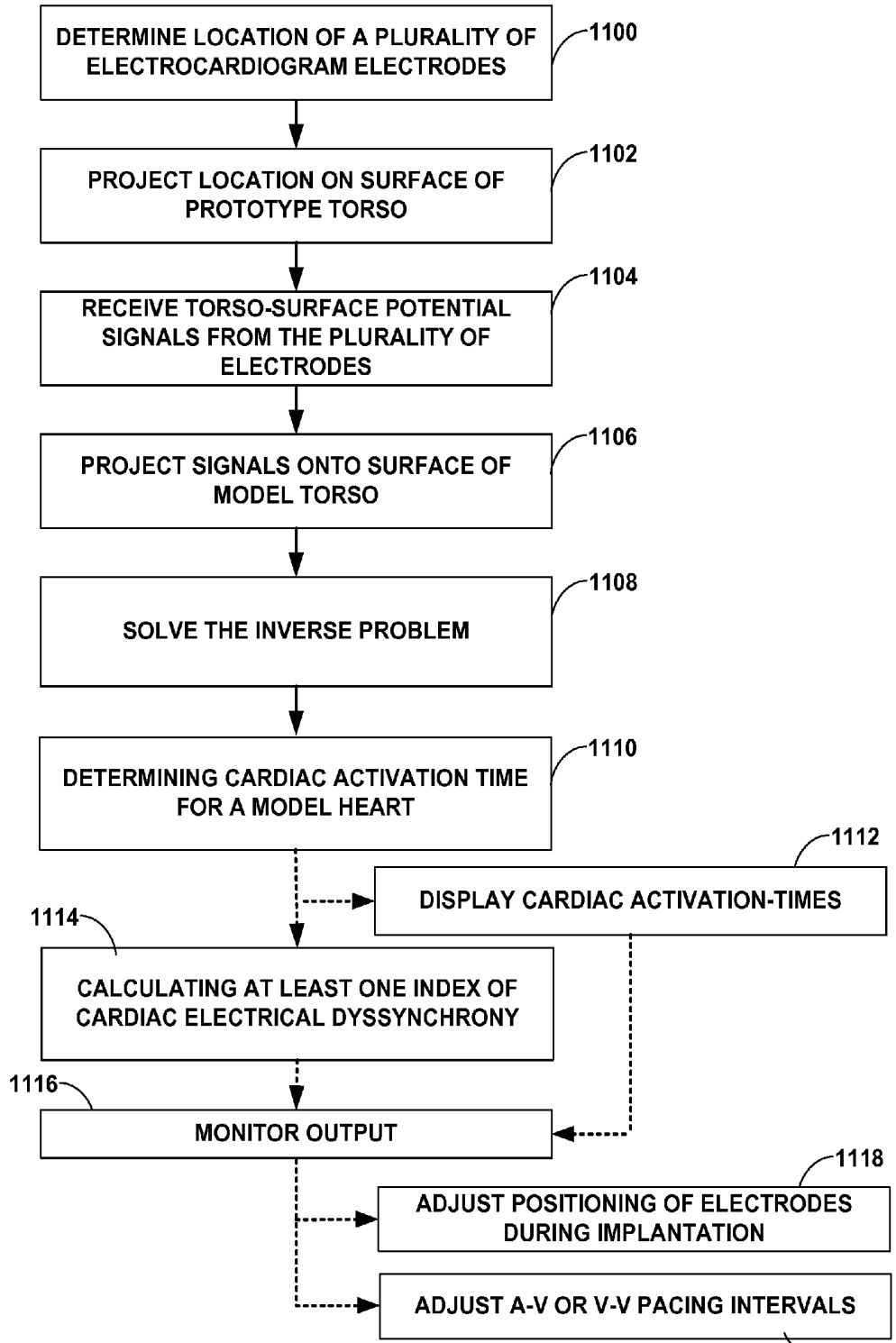

FIG. 11

ASSESSING INTRA-CARDIAC ACTIVATION PATTERNS

CROSS-REFERENCE TO RELATED APPLICATIONS

[0001] This application claims the benefit of U.S. Provisional Application No. 61/482,053 filed on May 3, 2011, the entire content of which is incorporated herein by reference.

TECHNICAL FIELD

[0002] The disclosure relates to electrophysiology and, more particularly, to evaluating the electrical activation patterns of the heart.

BACKGROUND

[0003] The beat of the heart is controlled by the sinoatrial node, a group of conductive cells located in the right atrium near the entrance of the superior vena cava. The depolarization signal generated by the sinoatrial node activates the atrioventricular node. The atrioventricular node briefly delays the propagation of the depolarization signal, allowing the atria to drain, before passing the depolarization signal to the ventricles of the heart. The coordinated contraction of both ventricles drives the flow of blood through the torso of a patient. In certain circumstances, the conduction of the depolarization signal from the atrioventricular node to the left and right ventricles may be interrupted or slowed. This may result in a dyssynchrony in the contraction of the left and right ventricles, and eventually in heart failure or death.

[0004] Cardiac Resynchronization Therapy (CRT) may correct the symptoms of electrical dyssynchrony by providing pacing therapy to one or both ventricles or atria, e.g., by providing pacing to encourage earlier activation of the left or right ventricles. By pacing the contraction of the ventricles, the ventricles may be controlled so that the ventricles contract in synchrony. Some patients undergoing CRT have experienced improved ejection fraction, increased exercise capacity, and an improved feeling of well-being.

[0005] Providing CRT to a patient may involve determining whether the patient will derive benefit from the CRT prior to implantation of a cardiac rhythm device, determining optimal site for placement of one or more ventricular pacing leads, and programming of device parameters, such as selection of electrodes on multi-polar right or left ventricular leads, as well as selection of the timing of the pacing pulses delivered to the electrodes, such as atrioventricular (A-V) and intra-ventricular (V-V) delays. Assessment of electrical dyssynchrony for these purposes has typically involved assessing QRS duration clinically. Though CRT is recommended typically for patients with wide QRS duration, hemodynamic improvements through CRT have been reported in narrow QRS heart failure patients. Thus, some patients who may benefit from CRT may not be prescribed CRT based on present electrical dyssynchrony evaluation techniques.

SUMMARY

[0006] In general, the disclosure is directed towards techniques for evaluating electrical dyssynchrony of the heart of a patient. The evaluation of electrical dyssynchrony may facilitate patient selection for CRT. The evaluation of electrical dyssynchrony may also facilitate placement of implantable leads, e.g., one or more left ventricular leads, and program-

ming of device parameters for CRT during an implantation procedure, or reprogramming of device parameters for CRT during a follow-up visit.

[0007] A set of electrodes may be spatially distributed about the torso of a patient. The electrodes may each sense a body-surface potential signal, and more particularly a torso-surface potential signal, which indicates the depolarization signals of the heart of the patient after the signals have progressed through the torso of the patient. Due to the spatial distribution of the electrodes, the torso-surface potential signal recorded by each electrode may indicate the depolarization of a different spatial region of the heart.

[0008] In some examples, an activation time is determined for each torso-surface potential signal, i.e., for each electrode of the set. The dispersion or sequence of these activation times may be analyzed or presented to provide variety of indications of the electrical dyssynchrony of the heart of the patient. For example, isochrone or other activation maps of the torso-surface illustrating the activation times may be presented to user to illustrate electrical dyssynchrony of the heart. In some examples, values of one or more statistical indices indicative of the temporal and/or spatial distribution of the activation times may be determined. Such maps and indices, or other indications of dyssynchrony determined based on the torso-surface activation times, may indicate electrical dyssynchrony of the heart to a user, and facilitate evaluation of a patient for CRT, and configuration of CRT for the patient.

[0009] In some examples, the locations of all or a subset of the electrodes, and thus the locations at which the torso-surface potential signals were sensed, may be projected on the surface of a model torso that includes a model heart. The inverse problem of electrocardiography may be solved to determine electrical activation times for regions of the model heart based on the torso-surface potential signals sensed from the patient. In this manner, the electrical activity of the heart of the patient may be estimated. Various isochrone or other activation time maps of the surface of the model heart may be generated based on the torso-surface potential signals sensed on the surface of the torso of the patient. Further, values of one or more indices indicative of the temporal and/or spatial distribution of the activation times on model heart may be determined. These measures and representations of electrical dyssynchrony may be used to evaluate the suitability of the patient for CRT, adjust the positioning of the CRT leads during implantation, and determine which electrodes of one or more multi-polar leads should be utilized for delivery of CRT, as well as the timing of pacing pulses, such as atrioventricular (A-V) and intra-ventricular (V-V) delays for delivery of CRT to the patient.

[0010] For example, the one or more indications of dyssynchrony may be determined or generated based on data collected both during intrinsic conduction and during CRT. The degree of dyssynchrony during intrinsic conduction and CRT may be compared, e.g., to determine whether a patient is a candidate for CRT. Similarly, the one or more indications of dyssynchrony may be determined or generated based on data collected during CRT with different lead positions, different electrode configurations, and/or different CRT parameters, e.g., A-V or V-V delay. The change in dyssynchrony attributable to these different lead positions, different electrode configurations, and/or different CRT parameters may be evaluated.

[0011] In one example, a method comprises receiving, with a processing unit, a torso-surface potential signal from each of a plurality of electrodes distributed on a torso of a patient. The method further comprises for at least a subset of the plurality of electrodes, calculating, with the processing unit, a torso-surface activation time based on the signal sensed from the electrode, and presenting, by the processing unit, to a user, an indication of a degree of dyssynchrony of the torso-surface activation times via a display.

[0012] In another example, a system comprises a plurality of electrodes distributed on a torso of a patient, and a processing unit. The processing unit is configured to receive a torso-surface potential signal from each of the plurality of electrodes, calculate, for at least a subset of the plurality of electrodes, a torso-surface activation time based on the signal sensed from the electrode, and present, to a user, an indication of a degree of dyssynchrony of the torso-surface activation times via a display.

[0013] In another example a computer-readable storage medium comprises instructions that, when executed, cause a processor to receive a torso-surface potential signal from each of a plurality of electrodes distributed on a torso of a patient, calculate, for at least a subset of the plurality of electrodes, a torso-surface activation time based on the signal sensed from the electrodes, and present to a user, an indication of a degree of dyssynchrony of the torso-surface activation times via a display.

[0014] The details of one or more aspects of the disclosure are set forth in the accompanying drawings and the description below. Other features, objects, and advantages will be apparent from the description and drawings, and from the claims.

BRIEF DESCRIPTION OF DRAWINGS

[0015] FIG. 1 is a conceptual diagram illustrating an example system that may be used to provide CRT to a heart of a patient.

[0016] FIG. 2 is a timing diagram showing an example ECG tracing of two healthy heart beats.

[0017] FIG. 3 is a timing diagram showing an example ECG tracing of a patient suffering from left bundle branch block.

[0018] FIGS. 4A and 4B are conceptual diagrams illustrating example systems for measuring torso-surface potentials.

[0019] FIG. 5 is a block diagram illustrating an example system for measuring torso-surface potentials.

[0020] FIG. 6 is a series of simulated isochrone maps of torso-surface activation times for typical left bundle branch block intrinsic rhythm and CRT pacing.

[0021] FIG. 7 is a flow diagram illustrating an example operation of a system to provide indications of the cardiac electrical dyssynchrony of a patient based on torso-surface activation times.

[0022] FIG. 8 is a flow diagram illustrating an example technique for prescribing and configuring CRT based on an assessment cardiac electrical dyssynchrony of a patient via the torso-surface activation times.

[0023] FIG. 9 is a series of isochrone maps of cardiac activation times constructed with two different heart-torso models using body-surface ECG data from the same patient.

[0024] FIG. 10 is a flow diagram illustrating an example operation of a system to measure the cardiac electrical dyssynchrony of a patient via the cardiac activation times.

[0025] FIG. 11 is a flow diagram illustrating an example technique for configuring CRT based on an assessment of cardiac electrical dyssynchrony of a patient via the cardiac activation times.

DETAILED DESCRIPTION

[0026] FIG. 1 is a conceptual diagram illustrating an example system that may be used to provide CRT to heart 10 of patient 1. The system may include an implantable medical device (IMD) 100. IMD 100 may be a CRT pacemaker or CRT defibrillator. IMD 100 may be equipped with one or more leads; leads 102, 104, and 106; that are inserted into or on the surface of the left ventricle 12, right ventricle 14, or right atrium 16 of heart 10. Leads 102, 104, and 106 may be equipped with one or more electrodes 108, 110, and 112.

[0027] Heart 10 may suffer from an electrical dyssynchrony. Electrical dyssynchrony may occur when the depolarization signals that start the contraction of ventricles 12 and 14 do not reach the ventricles in a coordinated manner, and results in an inefficient pumping action of heart 10. Patient 1 may experience symptoms of heart failure. Electrical dyssynchrony may be caused by damage to the electrical system of heart 10, e.g., a bundle branch block or damage to the fascicle of heart 10. Alternate conduction pathways may form within heart 10, but these pathways may slow the progress of the electrical depolarization signal and result in the asynchronous contraction of ventricles 12 and 14.

[0028] IMD 100 may provide CRT stimulation to heart 10 of patient 1. IMD 100 is depicted as being configured to deliver stimulation to right atrium 16, right ventricle 14, and left ventricle 12 of heart 10. In other examples, IMD 100 may be configured to deliver stimulation to other portions of heart 10 depending on the condition of patient 1. IMD 100 may interact with an external programmer (not shown) to adjust operating characteristics, such as A-V and V-V delays, of the therapy delivered by IMD 100. In some examples, IMD 100 may also be configured to sense the electrical activity of heart 10 through the electrodes on one or more of leads 102, 104, and 106.

[0029] As shown in FIG. 1, leads 102, 104, 106 may extend into the heart 10 of patient 1 to deliver electrical stimulation to heart 10 and synchronize the contraction of ventricles 12 and 14. Right ventricular lead 106 extends through one or more veins (not shown), the superior vena cava (not shown), and right atrium 16, and into right ventricle 14. Left ventricular coronary sinus lead 102 extends through one or more veins, the vena cava, right atrium 16, and into the coronary sinus (not shown) to a region adjacent to the free wall of left ventricle 12 of heart 10. Right atrial lead 104 extends through one or more veins and the vena cava, and into the right atrium 16 of heart 10.

[0030] In other configurations, IMD 100 may be equipped with more or fewer leads, depending on the requirements of the therapy provided to patient 1. For example, IMD 100 may be equipped with leads that extend to greater or fewer chambers of heart 10. In some example, IMD 100 may be equipped with multiple leads that extend to a common chamber of heart, e.g., multiple leads extending to the left ventricle 12. IMD 100 may also be equipped with one or more leads that are placed on the heart through other means providing access to the cardiac tissue, such as surgical epicardial lead placement, and other pericardial access approaches. In some examples, IMD 100 may be equipped with a left ventricular lead that is placed on the heart endocardially. Additionally,

although illustrated as implanted on the right side of patient 1 in FIG. 1, IMD 100 may in other examples be implanted on the left side of the pectoral region of the patient, or within the abdomen of the patient.

[0031] Electrodes 108, 110, and 112 may attach to portions of heart 10 to provide electrical stimulation or sense the electrical depolarization and repolarization signals of heart 10. Electrode 108, in right ventricle 14, may be affixed to the wall of heart 10 via a screw based mechanism. Electrode 110 may comprise multiple electrodes mounted the same lead, allowing lead 102 to both transmit therapeutic shocks as well as electrical sense data detected by electrode 110. Electrodes 110 and 112 may be attached to the surface of heart 10 via glue, barbs, or another permanent or semi-permanent attachment mechanism.

[0032] FIG. 2 is a timing diagram showing an example ECG tracing 200 in conjunction with certain periods or phases of the mechanical cardiac cycle. The depiction and associated description of FIG. 2 are generalized in the sense that the relationship between the timing of electrical and mechanical events is not necessarily as described for all subjects, or at all times for any given subject.

[0033] ECG tracing 200 depicts the electrical signal of two example healthy cardiac cycles. The electrical signal of a healthy heart comprises a series of 5 characteristic waves: the P-wave, Q-wave, R-wave, S-wave, and T-wave. Each of these waves, and the intervals between them, correspond to discrete events in the functioning of a healthy heart.

[0034] In general, at some point during period 202, which stretches from the peak of a P-wave to the peak of the subsequent R-wave, atrial systole occurs, which is the contraction of the atria that drives blood from the atria into the ventricles. Period 204, from the peak of the R-wave to the opening of the aortic valve, generally marks a period of isovolumetric contraction. The atrioventricular and aortic valves are closed, preventing blood flow and leading to an increase in pressure in the ventricles but not yet in the aorta. Period 206, bounded by the opening and closing of the aortic valves is generally when ejection occurs during the cardiac cycle. During ejection period 206 the ventricles contract and empty of blood, driving the blood into cardiovascular system. As the contraction of the ventricles complete, the pressure of the blood within the cardiovascular system closes the aortic valves. Period 208, bounded by the closing of the aortic valves and the opening of the atrioventricular valves, is the isovolumetric relaxation of the ventricles. Periods 210 and 212 are collectively known as the late diastole, where the whole heart relaxes and the atria fill with blood. Period 210 corresponds to a rapid inflow of blood while period 212 corresponds to diastasis, the period of slower flow blood into the atria before the atrial systole 202 occurs again.

[0035] The P-wave marks the stimulation of the atria and the beginning of the cardiac cycle. The atria contract under the stimulation, forcing blood into the ventricles. The PR segment marks the delay as the depolarization signal travels from the atrioventricular node to the Purkinje fibers. The Q-wave marks the depolarization of the interventricular septum as an initial part of the depolarization of the ventricles. The R-wave follows the Q-wave and represents the depolarization of the ventricles. The S-wave follows the R-wave and represents the later depolarization of the ventricles. The T-wave marks the recovery and repolarization of the ventricles in preparation for the next beat of the heart.

[0036] The QRS complex, spanning from the beginning of the Q-wave to the end of the S-wave, represents the electrical activation of the myocardium. Ventricular contraction of both the left and right ventricles is in response to the electrical activation. The QRS complex typically lasts from 80 to 120 ms. The relatively large amplitude of the QRS complex is due to the large muscle mass of the ventricles. Issues affecting the synchrony of the ventricular contraction may be demonstrated in the deformation of the QRS complex. For example, electrical dyssynchrony in the contraction of the ventricles can widen the R-wave or produce two R-wave peaks, typically labeled the r-wave and R'-wave, corresponding to the depolarization of each ventricle. The S-wave and the T-wave may be morphological different than in an ECG tracing of a healthy heart.

[0037] FIG. 3 is a timing diagram showing ECG tracing 300. ECG tracing 300 depicts the electrical signal of a patient suffering from a left bundle branch block. A sign of the condition is the presence of an rS complex versus the typical QRS complex, though other variations of Q, R, and S waves form combinations that may be present in patients suffering from a left bundle branch block, right bundle branch blocks, or other ventricular conduction conditions. The extended duration of the rS complex indicates an extended ventricular contraction time, likely due to electrical dyssynchronies.

[0038] Diagnosis of a left or right bundle branch block, or cardiac electrical dyssynchrony in general, typically involves measuring the duration of the QRS complex (or other complexes marking the depolarization of the ventricles). QRS complexes lasting 100 ms or longer may indicate a partial bundle branch block and 120 ms or longer a complete bundle branch block. In FIG. 3, the initial Q-wave is not visible, instead the tracing shows an initial r-wave, corresponding to the initial depolarization of the right ventricle and followed by an S-wave marking the rapid depolarization of both ventricles after the cardiac signal has reached the left ventricle after traveling through the myocardium of the heart, rather than through the bundle branches. Because the myocardium conducts electricity more slowly than the bundle branches, the entire complex is spread out over a longer period.

[0039] Absent a case of bundle branch block—such as the one shown in FIG. 3—or other condition, diagnosis may be more challenging. Occult dyssynchronies may be present that, while responsive to CRT, may not be readily identifiable from an examination of the typical 12-lead ECG. These occult dyssynchronies may manifest in the electrical signals generated by the heart and measured on the surface of the torso and may be diagnosable through alternative means of analysis, such as by determining cardiac activation times at a plurality of spatially distributed locations according to the techniques described herein.

[0040] FIGS. 4A and 4B are conceptual diagrams illustrating example systems for measuring body-surface potentials and, more particularly, torso-surface potentials. In one example illustrated in FIG. 4A, sensing device 400A, comprising a set of electrodes 404A-F (generically “electrodes 404”) and strap 408, is wrapped around the torso of patient 1 such that the electrodes surround heart 10. As illustrated in FIG. 4A, electrodes 404 may be positioned around the circumference of patient 1, including the posterior, lateral, and anterior surfaces of the torso of patient 1. In other examples, electrodes 404 may be positioned on any one or more of the posterior, lateral, and anterior surfaces of the torso. Electrodes 404 may be electrically connected to processing unit

500 via wired connection **406**. Some configurations may use a wireless connection to transmit the signals sensed by electrodes **404** to processing unit **500**, e.g., as channels of data.

[0041] Although in the example of FIG. 4A sensing device **400A** comprises strap **408**, in other examples any of a variety of mechanisms, e.g., tape or adhesives, may be employed to aid in the spacing and placement of electrodes **404**. In some examples, strap **408** may comprise an elastic band, strip of tape, or cloth. In some examples, electrodes **404** may be placed individually on the torso of patient **1**.

[0042] Electrodes **404** may surround heart **10** of patient **1** and record the electrical signals associated with the depolarization and repolarization of heart **10** after the signals have propagated through the torso of patient **1**. Each of electrodes **404** may be used in a unipolar configuration to sense the torso-surface potentials that reflect the cardiac signals. Processing unit **500** may also be coupled to a return or indifferent electrode (not shown) which may be used in combination with each of electrodes **404** for unipolar sensing. In some examples, there may be 12 to 16 electrodes **404** spatially distributed around the torso of patient **1**. Other configurations may have more or fewer electrodes **404**.

[0043] Processing unit **500** may record and analyze the torso-surface potential signals sensed by electrodes **404**. As described herein, processing unit **500** may be configured to provide an output to a user indicating the electrical dyssynchrony in heart **10** of patient **1**. The user may make a diagnosis, prescribe CRT, position therapy devices, e.g., leads, or adjust or select treatment parameters based on the indicated electrical dyssynchrony.

[0044] In some examples, the analysis of the torso-surface potential signals by processing unit **500** may take into consideration the location of electrodes **404** on the surface of the torso of patient **1**. In such examples, processing unit **500** may be communicatively coupled to an imaging device **501**, which may provide an image that allows processing unit **500** to determine coordinate locations of each of electrodes **400** on the surface of patient **1**. Electrodes **404** may be visible, or made transparent through the inclusion or removal of certain materials or elements, in the image provided by imaging system **501**.

[0045] FIG. 4B illustrates an example configuration of a system that may be used to evaluate electrical dyssynchrony in heart **10** of patient **1**. The system comprises a sensing device **400B**, which may comprise vest **410** and electrodes **404 A-ZZ** (generically “electrodes **404**”), a processing unit **500**, and imaging system **501**. Processing unit **500** and imaging system **501** may perform substantially as described above with respect to FIG. 4A. As illustrated in FIG. 4B, electrodes **404** are distributed over the torso of patient **1**, including the anterior, lateral, and posterior surfaces of the torso of patient **1**.

[0046] Sensing device **400B** may comprise a fabric vest **410** with electrodes **404** attached to the fabric. Sensing device **400B** may maintain the position and spacing of electrodes **404** on the torso of patient **1**. Sensing device **400B** may be marked to assist in determining the location of electrodes **404** on the surface of the torso of patient **1**. In some examples, there may be 150 to 256 electrodes **404** distributed around the torso of patient **1** using sensing device **400B**, though other configurations may have more or fewer electrodes **404**.

[0047] FIG. 5 is a block diagram illustrating an example system for measuring torso-surface potentials and providing indications of electrical dyssynchrony. The example system

may comprise a processing unit **500** and a set of electrodes **404** on a sensing device **400**, e.g., one of example sensing devices **400A** or **400B** (FIGS. 4A and 4B). The system may also include an imaging system **501**.

[0048] As illustrated in FIG. 5, processing unit **500** may comprise a processor **502**, signal processor **504**, memory **506**, display **508**, and user input device **509**. Processing unit **500** may also include an electrode location registration module **524**. In the illustrated example, processor **502** comprises a number of modules and, more particularly, a projection module **514**, an inverse problem module **516**, an activation time module **518**, an indices module **520**, and an isochrones mapping module **522**. Memory **506** may store recorded data **510** and models **512**.

[0049] Processing unit **500** may comprise one or more computing devices, which may be co-located, or dispersed at various locations. The various modules of processing unit **500**, e.g., processor **502**, projection module **514**, inverse problem module **516**, activation time module **518**, statistics module **520**, isochrones mapping module **522**, signal processor **504**, electrode location registration module **524**, display **508**, memory **506**, recorded data **510** and torso models **512** may be implemented in one or more computing devices, which may be co-located, or dispersed at various locations. Processor **502**, and the modules of processor **502**, may be implemented in one or more processors, e.g., microprocessors, of one or more computing devices, as software modules executed by the processor(s). Electrode location registration module **524** may, in some examples, be implemented in imaging system **501**.

[0050] In addition to the various data described herein, memory **506** may comprise program instructions that, when executed by a programmable processor, e.g., processor **502**, cause the processor and any components thereof to provide the functionality attributed to a processor and processing unit herein. Memory **506** may include any volatile, non-volatile, magnetic, optical, or electrical media, such as a hard disk, magnetic tape, random access memory (RAM), read-only memory (ROM), CD-ROM, non-volatile RAM (NVRAM), electrically-erasable programmable ROM (EEPROM), flash memory, or any other digital or analog media. Memory **506** may comprise one or more co-located or distributed memories. Memory **506** may comprise a tangible article that acts as a non-transitory storage medium for data and program instructions.

[0051] The torso-surface potential signals sensed by electrodes **404** of sensing device **400** may be received by signal processor **504** of processing unit **500**. Signal processor **504** may include an analog-to-digital converter to digitize the torso-surface potential signals. Signal processor **504** may also include various other components to filter or otherwise condition the digital signals for receipt by processor **502**.

[0052] Electrode location registration module **524** may receive imaging data from imaging system **501**. Electrode location registration module **524** analyzes the imaging data. In particular, electrode registration location module **524** identifies electrodes **404**, or elements co-located with the electrodes that are more clearly visible via the imaging modality, within the images. Electrode location registration module **524** may further identify the locations of each of the electrodes on the surface of the patient and/or within a three-dimensional coordinate system. In some examples, the locations of elec-

trodes 404 may be manually identified and registered with processing unit 500, e.g., by a user, via electrode registration module 524.

[0053] The imaging data may comprise data representing one or more images of patient 1 wearing electrodes 404, e.g., of a sensing device 400. In some examples, the images may be obtained before or during a medical procedure, e.g., a surgical procedure to implant a cardiac rhythm device and lead system for delivery of CRT.

[0054] In some examples, processor 502 may store the torso-surface potential signals, imaging data from imaging system, electrode location data from electrode location registration module, or any values disclosed herein that are derived by processing of such signals and data by processor 502, within memory 506 as recorded data 510. Each recorded torso-surface potential signal, or other values derived therefrom, may be associated with a location of the electrode 404 that sensed the torso-surface potential signal. In this manner, the torso-surface potential data may be correlated with the position of electrodes 404 on the torso of patient 1, or within a three-dimensional coordinate system, enabling spatial mapping of the data to particular locations on the surface of the torso or within the coordinate system. In some examples, aspects of the techniques described herein may be performed at some time after the acquisition of the torso-surface potential signals and location data based on recorded data 510.

[0055] Processor 502 may be configured to provide one or more indications of electrical dyssynchrony based on the torso-surface potential signals and, in some examples, the electrode location data. Example indications of electrical dyssynchrony include indices illustrating activation times for each electrode/location distributed about the torso or heart, or for one or more subsets of electrodes located within a common region, e.g., within a left posterior, left anterior, right posterior, or right anterior region. In some examples, processor 502 may be configured to provide a set of two or more different indications, e.g., several different indications, for each of two or more different regions, e.g., several different regions, of the torso or heart.

[0056] Some indications of dyssynchrony may include statistical values or other indices derived from activation times for each electrode location or one or more subsets of electrodes within one or more regions. Other examples indications of electrical dyssynchrony that may be determined based on activation times at various electrodes/locations include graphical indications, such as an isochrone or other activation maps, or an animation of electrical activation. Other examples indications of electrical dyssynchrony that may be determined based on activation times at various electrodes/locations include identifying one of a predetermined number of dyssynchrony levels, e.g., high, medium, or low, via text or color, e.g., red, yellow, green, for example.

[0057] In some examples, the various indications of dyssynchrony for one or more regions may be determined based on data collected at two or more different times and/or under two or more different conditions. For example, the various indications of dyssynchrony may be determined based on torso-potential signals collected during intrinsic conduction of heart 10, and also determined based on torso-potential signals collected during CRT. In this manner, the potential dyssynchrony-reducing benefit of CRT may be evaluated for the patient by comparing the different values, graphical representations, or the like, resulting from intrinsic conduction and CRT. As another example, the various indications of

dyssynchrony may be determined each of a plurality of different times based on torso-potential signals collected during delivery of CRT with different lead positions, electrode configurations, or CRT parameters, e.g., A-V or V-V interval values. In this manner, the relative dyssynchrony-reducing benefits of the different lead positions, electrode configurations, or CRT parameters positions may be evaluated for the patient by comparing the different values, graphical representations, or the like.

[0058] Models 512 may include a plurality of different models, e.g., three-dimensional models, of the human torso and heart. A model torso or model heart may be constructed by manual or semi-automatic image segmentation from available databases of previously acquired medical images (CT/MRI) of a plurality of subjects, e.g., cardiomyopathy patients, different than patient 1, using commercially available software. Each model may be discretized using a boundary element method. A plurality of different torso models may be generated. The different models may represent different subject characteristics, such as different genders, disease states, physical characteristics (e.g., large frame, medium frame and small frame), and heart sizes (e.g., x-large, large, medium, small). By providing input via user input 509, a user may select from among the various model torsos and model hearts that may be stored as models 512 in memory 506, so that the user may more closely match the actual torso and heart 10 of patient 1 with the dimensions and geometry of a model torso and model heart. In some examples, medical images of the patient, e.g., CT or MRI images, may be manually or semi-automatically segmented, registered, and compared to models 512 for selection from amongst the models 512. Furthermore, single or multiple view 2-D medical images (e.g., x-ray, fluoroscopy) may be segmented or measured to determine approximate heart and torso dimensions specific to the patient in order to select the best fit model torso and heart.

[0059] Projection module 514 may project the locations of electrodes 404, e.g., stored as recorded data 510 within of memory 506, onto an appropriate, e.g., user-selected, model torso contained in model data module 512 of memory 506. By projecting the location of electrodes 404 onto the model torso, projection module 514 may also project the torso-surface potential signals of patient 1 sensed by electrodes 404 onto the model torso. In other examples, the measured electrical potentials may be interpolated and resamples at electrode positions given by the model. In some examples, projecting the torso-surface potentials onto the model torso may allow processor 502, via inverse problem module 516, to estimate the electrical activity of at various locations or regions of the model heart corresponding to heart 10 of patient 1 that produced the measured torso-surface potentials.

[0060] Inverse problem module 516 may be configured to solve the inverse problem of electrocardiography based on the projection of the measured torso-surface potentials, recorded by electrodes 404, onto the model torso. Solving the inverse problem of electrocardiography may involve the estimation of potentials or activation times in heart 10 based on a relationship between the torso and heart potentials. In one example method, model epicardial potentials are computed from model torso potentials assuming a source-less volume conductor between the model heart and the model torso in an inverse Cauchy problem for Laplace's equation. In another example method, an analytic relationship between torso-surface potentials and the cardiac transmembrane potential is assumed. Torso-surface potentials may be simulated based on

this relationship. In some examples, inverse problem module 516 may utilize techniques described by Ghosh et al. in "Accuracy of Quadratic Versus Linear Interpolation in Non-Invasive Electrocardiographic Imaging (ECGI)," *Annals of Biomedical Engineering*, Vol. 33, No. 9, September 2005, or in "Application of the L1-Norm Regularization to Epicardial Potential Solution of the Inverse Electrocardiography Problem," *Annals of Biomedical Engineering*, Vol. 37, No. 5, 2009, both of which are incorporated herein by reference in their entireties. In other examples, any known techniques for solving the inverse problem of electrocardiography may be employed by inverse problem module 516.

[0061] Activation time module 518 may compute the activation times directly from measured torso-surface potentials, or by estimating model transmembrane potentials. In either case, an activation time for each electrode/location may be determined as a time period between two events, such as between the QRS complex onset and the minimum derivative (or steepest negative slope) of the sensed torso potential signal or estimate epicardial potential signal. Thus, in one example, cardiac activation times are estimated from the steepest negative slope of the model epicardial electrograms. Cardiac activation times (parameters in the analytic relationship between torso-surface potential and cardiac transmembrane potential) may, in other configurations, be computed based on minimizing the least square difference between the measured torso-surface potentials and simulated torso-surface potentials. A color-coded isochrone map of ventricular, epicardial, or torso-surface activation times may be shown by display 308. In other examples, display 308 may show a two-color animation of propagation of the activation wavefront across the surface of the model heart or the torso-surface.

[0062] Indices module 520 may be configured to compute one or more indices of electrical dyssynchrony from the torso-surface or cardiac activation times. These indices may aid in the determination of whether the patient is a candidate for CRT, placement of CRT leads, and selection of CRT parameters. For example, LV lead 102 (FIG. 1) may be positioned at the site that reduces dyssynchrony from one or more indices or, alternatively, the largest electrical resynchronization as demonstrated by the indices. The same indices may be also used for programming A-V and/or V-V delays during follow-up. As indicated above, the indices may be determined based on the activation times for all electrodes/locations, or for one or more subsets of electrodes in one or more regions, e.g., to facilitate comparison or isolation of a region, such as the posterior and/or left anterior, or left ventricular region.

[0063] One of the indices of electrical dyssynchrony may be a standard deviation index computed as the standard deviation of the activations-times (SDAT) of some or all of electrodes 404 on the surface of the torso of patient 1. In some examples, the SDAT may be calculated using the estimated cardiac activation times over the surface of a model heart.

[0064] A second example index of electrical dyssynchrony is a range of activation times (RAT) which may be computed as the difference between the maximum and the minimum torso-surface or cardiac activation times, e.g., overall, or for a region. The RAT reflects the span of activation times while the SDAT gives an estimate of the dispersion of the activation times from a mean. The SDAT also provides an estimate of the heterogeneity of the activation times, because if activation times are spatially heterogeneous, the individual activation times will be further away from the mean activation time,

indicating that one or more regions of heart 10 have been delayed in activation. In some examples, the RAT may be calculated using the estimated cardiac activation times over the surface of a model heart.

[0065] A third example index of electrical dyssynchrony estimates the percentage of electrodes 404 located within a particular region of interest for the torso or heart, whose associated activation times are greater than a certain percentile, for example the 70th percentile, of measured QRS complex duration or the determined activation times for electrodes 404. The region of interest may be a posterior, left anterior, and/or left-ventricular region, as examples. This index, the percentage of late activation (PLAT), provides an estimate of percentage of the region of interest, e.g., posterior and left-anterior area associated with the left ventricular area of heart 10, which activates late. A large value for PLAT may imply delayed activation of substantial portion of the region, e.g., the left ventricle 12 (FIG. 1), and the potential benefit of electrical resynchronization through CRT by pre-exciting the late region, e.g., of left ventricle 12. In other examples, the PLAT may be determined for other subsets of electrodes in other regions, such as a right anterior region to evaluate delayed activation in the right ventricle. Furthermore, in some examples, the PLAT may be calculated using the estimated cardiac activation times over the surface of a model heart for either the whole heart or for a particular region, e.g., left or right ventricle, of the heart.

[0066] Isochrone module 522 may be configured to generate an isochrone map depicting the dispersion of activation times over the surface of the torso of patient 1 or a model heart. Isochrone module 522 may incorporate changes in the torso-surface or cardiac activation times in near real-time, which may permit near instant feedback as a user adjusts a CRT device or monitors patient 1 to determine if CRT is appropriate. Isochrone maps generated by isochrone module 522 may be presented to the user via display 508.

[0067] In general, processor 502 may generate a variety of images or signals for display to a user via display 508 based on the measured torso-surface potentials, calculated torso-surface or estimated cardiac activation times, or the degree of change in electrical dyssynchrony. For example, a graded response reflecting the efficacy of a particular location of the LV lead 102 during biventricular pacing or single ventricle fusion pacing may be provided to the physician in terms of a red, yellow and green signal. A red signal may be shown if the reduction in electrical dyssynchrony during CRT pacing compared to intrinsic rhythm is negative (an increase in electrical dyssynchrony) or minimal, e.g., less than 5%. A yellow signal may be triggered if there is some reduction in electrical dyssynchrony during CRT pacing compared to intrinsic rhythm, for example between 5% and 15%, but there may be potentially better sites for lead placement. If the reduction in electrical dyssynchrony during CRT pacing compared to intrinsic rhythm is substantial, e.g., greater than 15%, a green signal may be triggered indicating to the physician that the present site provides effective changes in synchronization. The feedback from this system in combination with other criteria (like magnitude of pacing threshold, impedance, battery life, phrenic nerve stimulation) may be also used to choose an optimal pacing vector for one or more multipolar leads. The feedback from this system may be also used for selecting optimal device timings (A-V delay, V-V delay, etc) influencing the extent of fusion of intrinsic activation with paced activation from single or multiple ventricular sites, or

discerning acute benefit of single site fusion pacing versus multi-site pacing and choice of appropriate pacing type.

[0068] Display 508 may also display three-dimensional maps of electrical activity over the surface of the torso of patient 1 or over a model heart. These maps may be isochrone maps showing regions of synchronous electrical activity as the depolarization progresses through heart 10 of patient 1. Such information may be useful to a practitioner in diagnosing asynchronous electrical activity and developing an appropriate treatment, as well as evaluating the effectiveness of the treatment.

[0069] FIG. 6 is a series of simulated isochrone maps 600 of torso-surface activation times over the torso of a patient suffering from an electrical dyssynchrony in the left ventricle before and during treatment with a CRT device. The isochrone maps before (intrinsic) and after treatment are divided into two views: anterior and posterior. Line 602 represents the location of a subset of electrodes 404, e.g., a subset of electrodes 404 of sensing device 400B, that may be used to calculate one or more indices of electrical dyssynchrony. In some examples, line 602 may represent electrodes 404 on sensing device 400A.

[0070] The isochrone maps 600 of the natural and CRT assisted torso-surface activation times may be generated using multiple electrodes 404 distributed over the surface of the torso of a patient, e.g., using sensing device 400B. Generation of the isochrone maps 600 may include determining the location of electrodes 404, and sensing torso-surface potential signals with the electrodes. Generation of the isochrone maps 600 may further include calculating the torso-surface activation time for each electrode or electrode location by determining the point in the recorded QRS complex of the signal sensed by the electrodes corresponding to the maximum negative slope. In other examples, the torso-surface activation times may be determined by identifying the minimum derivative of the QRS complex. The measured torso-surface activation times may then be standardized and an isochrone map of the surface of the torso of the patient generated.

[0071] The delayed activation of certain locations associated with certain ones of electrodes 404 due to the electrical dyssynchrony is apparent in the posterior views of the intrinsic torso-surface activation times. Regions 604 indicate increased delay in the activation of the underlying heart. The corresponding posterior view during treatment with a CRT device indicate that regions 606, the same location as regions 604 on the maps of intrinsic torso-surface activation times, exhibits increased synchrony in electrical ventricular activity. The CRT maps exhibit decreased range and a lower standard deviation of torso-surface activation times. Further, the posterior regions no longer exhibit delayed activation times. The isochrone map of the torso-surface activation times during intrinsic and CRT pacing and changes in distribution of activation-times from intrinsic to CRT pacing may be used for diagnostic purposes or the adjustment of a CRT device.

[0072] One or more indices of electrical dyssynchrony may also be calculated from the torso-surface activation times used to generate isochrone maps 600. For example, SDAT, an indication of the spread of the activation times, for the patient's intrinsic heart rhythm using the complete set of electrodes 404 is 64. Using the reduced lead set marked by line 602 results in an SDAT of 62. The RAT for the intrinsic heart rhythm and complete lead set is 166.5 while the reduced lead set has a RAT of 160. PLAT for the intrinsic heart rhythm

using the reduced and complete lead sets are 56.15% and 66.67%, respectively. This indicates that using a reduced lead set that circumscribes the heart of the patient, e.g., sensing device 400A and associated electrodes 404, may provide comparable indices of electrical dyssynchrony compared to using an electrode set covering the torso of the patient, such as sensing device 400B.

[0073] The indices of electrical dyssynchrony also provide indication of the effectiveness of the CRT device, with the SDAT for the reduced set of electrodes declining to 24, the RAT to 70 and PLAT to 36%. This indicates that the torso-surface activation times during CRT treatment were more narrowly distributed and in a smaller range than in the normal heart rhythm and that the percentage of electrodes 404 located on the left anterior surface of the torso of the patient registering late activation times decreased markedly.

[0074] FIG. 7 is a flow diagram illustrating an example operation of a system to evaluate the cardiac electrical dyssynchrony of a patient via the torso-surface activation times. The location of electrodes, e.g., electrodes 404 (FIGS. 4A and 4B), distributed over the surface of the torso of the patient may be determined (700). A cardiac event, e.g., a depolarization, may generate an electrical signal that propagates through the torso of a patient, e.g., patient 1 (FIG. 1) and registers on the electrodes. The signal sensed by the electrodes may be received (702), e.g., by processing unit 500 (FIG. 5). The processing unit may calculate the torso-surface activation times (704). In some examples, the processing unit may also construct a torso-surface activation times isochrone map (706). The processing unit may also calculate at least one index of cardiac electrical dyssynchrony (708). These indices may comprise one or more of the SDAT (710), RAT (712), and the PLAT (714).

[0075] A cardiac event, such as a depolarization, generates an electrical signal that propagates through the torso. The electrical signal may comprise a QRS complex, or a variant caused by a heart related condition such as a left or right bundle branch block. The electrical signal may not propagate uniformly through the torso of a patient due to variations in conductivity within the torso and the heart. These delays may manifest in electrodes distributed over the surface of the torso of the patient registering the same electrical signal at different points in time.

[0076] The electrical signal generated by the cardiac event may register on the plurality of electrodes distributed over the surface of the torso of patient. The electrodes may be distributed over the anterior, lateral, and/or posterior surfaces of the torso, allowing the generation of a three-dimensional picture of the electrical activity occurring within the torso. In some examples, the electrodes may be placed to provide extensive coverage both above and below the heart, e.g., by using sensing device 400B (FIG. 4B). In other examples, a reduced set of electrodes may be arranged around the circumference of the torso, circumscribing the heart of the patient, e.g., using sensing device 400A (FIG. 4A). The electrodes may receive the complete waveform of the electrical signal generated by the cardiac event, and transmit the signal to a processing unit.

[0077] The location of electrodes distributed over the surface of the torso of the patient may be determined (700). Locating the electrodes may be performed automatically, e.g., by imaging system 501 and electrode location registration module 524 of processing unit 500 (FIG. 5). The electrodes may be located by analyzing one or more images of the torso of a patient and performing a pattern matching routine, e.g.,

recognizing the shape of an electrode against the torso of the patient, and storing the location of the electrode on the torso of the patient in processing unit memory. In other examples, the location of sensing device 400A or 400B may be determined and the locations of the electrodes determined based on the position of the sensing device, e.g., basing the position of the electrode on the patient through the known position of the electrode on the sensing device. In another example, the position of the electrodes may be measured manually.

[0078] The processing unit may receive the electrical signal from the electrodes and record the output in memory (702). The processing unit may record the raw output, e.g., the raw ECG tracing from each electrode, as well as location data for the electrodes, allowing the electrical signals detected by the electrodes to be mapped onto the surface of the torso of the patient.

[0079] The processing unit may compute the torso-surface activation times (704). A processor, e.g., processor 502 of processing unit 500 (FIG. 5), may retrieve ECG tracing data stored within the processing unit memory and analyze the tracing to detect depolarization of the ventricles of the heart, typically marked by a QRS complex in the tracing. The processor may, in some examples, detect ventricular depolarization by determining the time of the minimum derivative (or steepest negative slope) within the QRS complex measured with respect to the time of QRS complex onset. The determination of the activation time may be made for each electrode and stored in the processing unit memory.

[0080] In some configurations, the processing unit may construct an isochrone map of the torso-surface activation times, allowing the user to visually inspect the propagation of the electrical signals of the heart after progression through the torso of the patient. The isochrone map may be constructed by dividing the range of measured torso-surface activation times into a series of sub-ranges. The location of each electrode on the surface of the torso of the patient may be graphically represented. Regions of electrodes whose measured activation times fall within the same sub-range may be represented by the same color on the graphical representation.

[0081] The processing unit may also calculate one or more indices of electrical dyssynchrony based on the torso-surface activation times (708). These indices may include the SDAT (710), RAT (712), and PLAT (714). In some examples, the PLAT may be determined as the percentage of posterior electrodes activating after a certain percentage of the QRS complex duration.

[0082] As discussed above, in some examples, the construction of a torso-surface activation times isochrone map (706), or other graphical representation of dyssynchrony, as well as the calculation of indices of electrical dyssynchrony (708), may be performed for a particular region of the torso based the signals received from electrodes (702) in such regions. Graphical representations and indices of electrical dyssynchrony may be determined for each of a plurality of regions based on the signals received from the electrodes for such regions. In some examples, the representations and indices for various regions may be presented together or compared.

[0083] FIG. 8 is a flow diagram diagram illustrating an example technique for measuring the cardiac electrical dyssynchrony of a patient via measured torso-surface activation times. A processing unit 500 may receive torso-surface potential signals from a plurality of electrodes (800), e.g., electrodes 404 (FIGS. 4A and 4B). The processing unit 500 may

calculate the torso-surface activation times for each of the plurality of electrodes (802). The processing unit 500 may provide at least one indication of cardiac electrical dyssynchrony (804).

[0084] A user may evaluate the whether a patient is a candidate for CRT based on the at least one indication of electrical dyssynchrony (806). The user may also monitor the at least one indication of electrical dyssynchrony (808), and use the changes in the at least one indication to aid in adjusting the positioning of electrodes, e.g., electrodes 108, 110, and 112 (FIG. 1), during implantation of a CRT device (810), e.g., IMD 100 (FIG. 1), or selection of the various programmable parameters, such as electrode combination and the A-V or V-V pacing intervals, of the CRT device (812), during implantation or a follow-up visit.

[0085] The various indications of cardiac electrical dyssynchrony described herein, such as statistical or other indices, or graphical representations of activation times, may indicate the presence of damage to electrical conductivity of the heart of the patient, for example the presence of a left or right bundle branch block, that may not be apparent from the examination of a standard 12-lead ECG readout. For example, a large SDAT indicates that the activation of the ventricles is occurring over a large time span, indicating that the depolarization of the ventricles is not occurring simultaneously. A large RAT also indicates a broad range of activation times and asynchronous contraction of the ventricles. A high PLAT indicates that a specific region of the heart, e.g., the posterior regions associated with the left ventricle, may be failing to activate in concert with the measured QRS complex. Additionally, by monitoring the at least one indication of cardiac electrical dyssynchrony, the user may detect changes in the electrical activity of the heart caused by different treatments or treatment configurations.

[0086] As described above, the various indications of electrical dyssynchrony, such as statistical indexes, may be calculated for each of a plurality of regions, e.g., posterior, left anterior, or the like, based on torso-surface activations times from the region. Additionally, evaluating whether a patient is a candidate for CRT based on the at least one indication of electrical dyssynchrony (806) may include determining the one or more indications of electrical dyssynchrony based on torso-surface activation times both during intrinsic conduction of the heart, and during CRT. Differences between the indications during intrinsic conduction and CRT may indicate that CRT would provide benefit for the patient, e.g., that the patient is a candidate for CRT. As described above, the user may also evaluate whether a patient is a candidate for CRT based on at least one indication of electrical dyssynchrony based on intrinsic rhythm alone. Furthermore, monitoring the at least one indication of electrical dyssynchrony (808) during implantation or a follow-up visit may include determining the one or more indications of electrical dyssynchrony for each of a plurality of lead positions, electrode configurations, or other parameter values based on torso-surface activation times resulting from delivery of CRT at the positions, or with the electrode configurations or parameter values. In this manner, differences between dyssynchrony indications associated with various locations, electrode configurations, or parameter values may be compared to determine preferred locations, configurations, or values.

[0087] FIG. 9 is a series of isochrone maps of cardiac activation times. Views 900, 902 and 904 were constructed using torso-surface potentials measured on the surface of the

torso of a patient and projected onto three dimensional models of the torso and the heart of the patient. Views **910**, **912**, and **914** were constructed using the measured torso-surface potentials of the same patient projected onto a different model torso and model heart.

[0088] The three-dimensional representation of the hearts depicted in views **900**, **902**, **904**, **910**, **912** and **914** were constructed using computer tomography (CT) images of hearts obtained from databases of previously acquired cardiothoracic images. The locations of the electrodes, e.g., electrodes **404** of sensing device **400B** (FIG. 4B), on the torso of the patient may be plotted to approximate locations on a model torso. A computer may be used to solve the inverse problem of electrocardiography, which includes determining the electrical activity on the surface of the heart that would produce the measured torso-surface potentials. The isochrone maps illustrated in views **900**, **902**, **904**, **910**, **912** and **914** are based on images of hearts of two different patients, which are also used to determine the geometry of the heart and relationship to the corresponding torso for solving the inverse problem of electrocardiography.

[0089] The model torsos and hearts may be constructed by manual or semi-automatic image segmentation from available databases of previously acquired medical images (CT/MRI) of cardiomyopathy patients using commercially available software. Each model may be discretized using boundary element method and may be further manipulated to account for patients with different physical characteristics (e.g., large frame, medium frame and small frame) and heart sizes (e.g., x-large, large, medium, small).

[0090] A user may select the appropriate model torso and heart to suit the patient, e.g., a patient having a large torso may be simulated with a large frame model torso. In some examples, medical images of the patient, e.g., CT or MRI images, may be manually or semi-automatically segmented, registered, and compared to a variety of available models for selection from amongst the models. One or more views of 2-D medical images (e.g., X-ray or fluoroscopy) may also be used. The user may project the measured torso-surface potentials from the torso of the patient onto the corresponding locations on the model torso. The inverse problem of propagating the electrical signals from the model torso to the model heart may then be solved, and activation times for the model heart may be estimated.

[0091] In one example in which the techniques of this disclosure were applied, human thoracic CT images for other subjects were obtained from image databases. Semi-automatic image segmentation was performed on the images to generate the three-dimensional representation of the different models of hearts and torsos. In some examples, image segmentation may be done with the AMIRA software package commercially-available from Visage Imaging, Inc., of San Diego, Calif.

[0092] For the example, the projection of electrode locations on the patient torso to the model torso was approximate. In particular, the locations electrodes on the patient torso to the model torso the locations of the electrodes on the patient torso were projected onto the surface of the model torso based on the order in which the electrodes were mounted on the patient. For the purpose of this projection, the patient and model torsos were divided into right anterior, left anterior, right posterior and left posterior regions, using the sternum (anterior) and the spine (posterior) as references. Electrodes were arranged in vertical strips and three strips were applied

to each region of the torso. Electrodes in these regions were projected on to the corresponding segments of the model torso. The method described is one of many techniques that may be used to registered or map the geometrical distribution of measured electrical potentials. For example, the measured electrical potentials. For example, the measured electrical potentials may be interpolated and resampled at electrode positions given by the model. Projection of the electrode locations from segments of the patient torso onto the corresponding segments of the model torso in the correct order enabled the activation patterns and spatial dispersion of activation on the model heart to reflect the activation patterns and spatial dispersion of activation on the actual patient heart with relative accuracy. In one example, the inverse problem of electrocardiography may be solved using the Matlab regularization toolbox (Hansen PC, Regularization Tools : A Matlab package for analysis and solution of discrete ill-posed problems, Numerical Algorithms, 6(1994), pp 1-35).

[0093] Input data-sets for solving the inverse problem consistent with the example may include multi-electrode surface ECG measurements, the 3-D Cartesian coordinates of the model heart and torso surfaces, and the mesh over each model surface which specified the connectivity of the different points on each surface. An output consistent with the techniques of this disclosure may include activation times on the 3-D model heart surface which can be visualized using visualization software and computer graphics tools. In some examples, the 3-D model heart surface may be visualized using the tools in Matlab (Mathworks Inc, Natick, Mass.) or more advanced visualization software, such as Tecplot (Tecplot Inc, Bellevue, Wash.).

[0094] Comparing estimated cardiac activation times on two different, both cardiac activation times determined from the same torso-surface potential signals for one subject, show similar patterns and distribution. For example, region **906** of views **902** and **904** corresponds in size and activation time to region **916** of views **912** and **914**. Region **908** of views **902** and **904** corresponds to region **918** of views **912** and **914**.

[0095] Additionally, the standard deviations of activations time for both models are both derived from the same torso-surface potentials for one subject, were similar (17.6 and 15.5 ms). The overall pattern of cardiac activation and measures of dispersion of cardiac activation times are thus not dependent on a specific heart-torso model. Using a generic heart-torso model may allow a user to create an isochrone model of the cardiac activation time suitable for diagnosis and observation while avoiding expense, inconvenience, and radiation exposure that may be caused by the CT scan or other imaging that may be used to produce a patient-specific model of the heart of the patient.

[0096] FIG. 10 is a flow diagram illustrating an example operation of a system to measure the cardiac electrical dyssynchrony of a patient via the cardiac activation times. Processing unit **500** determines the location of the electrodes **404**, e.g., based on an analysis of imaging data by an electrode location registration module **524**. Processing unit projects the locations of the electrodes onto a model torso, e.g., a selected model torso (**1002**).

[0097] A cardiac event, e.g., depolarization, occurs causing an electrical signal to propagate through the torso of the patient, and register on the electrodes distributed on the surface of the torso of the patient. The torso-surface potential signals sensed by the electrodes may be received by processing unit **500** (**1004**). The processing unit may project the

signals onto the surface of the model torso based on the determined locations of the electrodes (1006).

[0098] The processing unit may solve the inverse problem of determining epicardial potentials based on torso-surface potentials (1008). The processing unit may then calculate cardiac activation times at a variety of locations of the model heart based upon the projected torso-surface potentials (1010). The cardiac activation times may be computed by, for example, determining the greatest negative slope of the epicardial electrogram potentials (1016) or by least squares minimization in the solution of the inverse problem (1018). The cardiac activation time may be displayed (1012). Examples of potential methods for displaying cardiac activation times include isochrone maps (1014) and a movie depicting the progression of the wavefront over the model heart (1016). The processing unit may be configured to allow a user select between, or display simultaneously, various display modes, including the wave front movie and isochrone maps. Additionally, one or more indices of cardiac electrical dyssynchrony may be calculated (1018), including the SDAT (1020), RAT (1022), and PLAT (1024).

[0099] For solving the inverse problem (1008), epicardial potentials may be computed from projected torso-surface potentials assuming a source-less volume conductor between the heart and the torso in an inverse Cauchy problem for Laplace's equation. Alternatively, an analytic relation between torso-surface potentials and the cardiac transmembrane potential may be assumed. Additionally, cardiac activation times may be estimated (1010) from the steepest negative slope of the epicardial electrograms determined from the inverse solution of the torso-surface potential/epicardial potential transformation. In other examples, model torso-surface potentials may be simulated based on the analytic relationship approach to determining the cardiac transmembrane potential from torso-surface potential. Cardiac activation times (parameters in the analytic relationship) may be computed based on minimizing the least square difference between the projected model torso-surface potentials and simulated torso-surface potentials.

[0100] In some examples, the construction of a torso-surface activation times isochrone map (1014), wavefront animation (1016), or other graphical representation of cardiac electrical dyssynchrony, as well as the calculation of indices of cardiac electrical dyssynchrony (1018), may be performed for a particular region of the model heart based the computed cardiac activation times in such regions. Graphical representations and indices of cardiac electrical dyssynchrony may be determined for each of a plurality of regions based on the computed cardiac activation times in such regions. In some examples, the representations and indices for various regions may be presented together or compared.

[0101] FIG. 11 is a flow diagram illustrating an example technique for measuring the cardiac electrical dyssynchrony of a patient via determined cardiac activation times. The techniques may comprise determining the location of a plurality of electrodes (1100), projecting the location of the electrodes onto the surface of a model torso (1102), recording the output of the plurality of electrodes (1104), projecting the output of the plurality of the electrodes on the surface of the model torso (1106), solving the inverse problem (1108) and determining the cardiac activation times for a model heart from the projected torso-surface potentials (1110). The cardiac activation times may be displayed (1112). One or more indices of electrical dyssynchrony may be calculated (1114).

The output, the indices of cardiac electrical dyssynchrony and cardiac activation time maps, may be monitored, allowing a user to diagnose the patient, adjust the position of CRT electrodes during implantation (1118), or adjust A-V or V-V pacing intervals of the CRT device (1120).

[0102] A user may monitor the output of the calculations (1116), e.g., the at least one indices of cardiac electrical dyssynchrony or the display of cardiac activation times. Monitoring these values may allow the user to diagnose a condition that might benefit from CRT or to evaluate the effectiveness of CRT. For example, the at least one index of cardiac electrical dyssynchrony may indicate the presence of damage to electrical conductivity of the heart of the patient, for example the presence of a left or right bundle branch block, that may not be apparent from the examination of a standard 12 lead ECG readout. A large SDAT indicates that the activation of the ventricles is occurring over a large time span, indicating that the depolarization of the ventricles is not occurring simultaneously. A large RAT also indicates a broad range of activation times and asynchronous contraction of the ventricles. A high PLAT may indicate that a specific region of the heart, e.g., the posterior regions more associated with the left ventricle, is failing to activate in concert with the measured QRS complex.

[0103] The user may adjust the positioning of CRT electrodes, e.g., electrodes 108, 110, and 112 of IMD 100 (FIG. 1) according to the displayed cardiac activation times or the indices of cardiac electrical dyssynchrony. For example, the processing unit, via a display, may implement system that displays shifting colors based on the percentage change of the indices of cardiac electrical dyssynchrony. As the position of the CRT electrodes are adjusted (1118), the displayed colors may shift from red to yellow to green based on the percentage improvement of the indices of cardiac electrical dyssynchrony. This may allow a user to rapidly determine if the adjustments of the CRT electrodes are having a positive effect on the symptoms of the patient. In another example, the user may adjust the A-V or V-V pacing intervals of an implanted CRT device (118). The minimum value of the indices of cardiac electrical dyssynchrony may indicate adequate pacing intervals. Isochrone maps or wave front propagation movies may also be used to aid in CRT adjustments or to diagnose conditions that may be responsive to CRT treatment.

[0104] As indicated above, to facilitate evaluating the whether a patient is a candidate for CRT based on the monitored output (1116), the one or more indications of cardiac electrical dyssynchrony, e.g., indices or graphical indications, may be determined based on torso-surface activation times during both intrinsic conduction of the heart, and during CRT. Differences between the indications during intrinsic conduction and CRT may indicate that CRT would provide benefit for the patient, e.g., that the patient is a candidate for CRT. Furthermore, during implantation or a follow-up visit, the one or more indications of cardiac electrical dyssynchrony may be determined for each of a plurality of lead positions, electrode configurations, or other parameter values based on torso-surface activation times resulting from delivery of CRT at the positions, or with the electrode configurations or parameter values. In this manner, differences between cardiac electrical dyssynchrony indications associated with various locations, electrode configurations, or parameter values may be compared to determine preferred locations, configurations, or values.

[0105] Various examples of this disclosure have been described. However, one of ordinary skill in the art will appreciate that various modifications may be made to the described embodiments without departing from the scope of the claims. For example, although SDAT, RAT and PLAT have been discussed as example statistical indices of the dispersion of activation times, other indices or metrics of the dispersion of the timing of depolarization may be determined according to the techniques of this disclosure. As one example, a range of activation times between two specific regions, e.g., anterior and posterior, may be determined. As another example, a range or variability of activation times after excluding certain locations or regions may be determined according to the techniques of this disclosure. The excluded locations or regions may be those that are believed to be scar tissue, e.g., identified by low amplitude electrical signals, or locations or regions that are beyond the extent of the far-field QRS complex. In general, calculation of an index may include determining any statistical or other value based on the torso-surface or cardiac activation times, or some subset thereof. These and other examples are within the scope of the following claims.

1. A method comprising:
 - determining a location of each of a plurality of electrodes distributed on a torso of a patient;
 - projecting, with a processing unit, the locations of the plurality of electrodes onto a surface of a model torso;
 - receiving, by the processing unit, a torso-surface potential signal sensed by each of the plurality of electrodes;
 - projecting, by the processing unit, each of the torso-surface potential signals onto a respective location on the surface of the model torso based on the determined locations of the electrodes; and
 - determining, by the processing unit, a set of cardiac activation times for a model heart within the model torso based on the projected torso-surface potential signals and a location of the model heart within the model torso.
2. The method of claim 1, further comprising selecting the model torso and model heart from a plurality of model torsos and model hearts based on at least one characteristic of the patient.
3. The method of claim 2, wherein selecting the model torso and model heart from the plurality of model torsos and model hearts based on at least one characteristic of the patient comprises selecting the model torso and model heart from the plurality of model torsos and model hearts based on manual or semi-automatic segmentation and registration of medical images taken from the patient.
4. The method of claim 2, wherein the model hearts and the model torsos are constructed by manual or semi-automatic image segmentation of medical images from subjects other than the patient.
5. The method of claim 2, wherein the model torsos are differentiated by at least one of gender or size, and the model hearts are differentiated by at least one of size or disease state.
6. The method of claim 1, wherein determining a set of cardiac activation-times for the model heart comprises calculating a set of epicardial potentials from the projected torso-surface potentials.
7. The method of claim 6, wherein calculating the set of epicardial potentials comprises assuming a source-less volume conductor between the model heart and the model torso in an inverse Cauchy problem for Laplace's equation.

8. The method of claims 6, wherein calculating the set of epicardial potentials comprises:
 - assuming an analytic relationship between the projected torso-surface potentials and a cardiac transmembrane potential;
 - simulating torso-surface potentials based on the analytic relationship; and
 - identifying epicardial potentials that minimize the least square difference between the projected torso-surface potentials and the simulated torso-surface potentials.
9. A system comprising:
 - a plurality of electrodes distributed on a torso of a patient; and
 - a processing unit configured to project the locations of the plurality of electrodes onto a surface of a model torso, receive a torso-surface potential signal sensed by each of the plurality of electrodes, projecting each of the torso-surface potential signals onto a respective location on the surface of a model torso based on the determined locations of the electrodes, and determine a set of cardiac activation times for a model heart within the model torso based on the projected torso-surface potential signals and a location of the model heart within the model torso.
10. The system of claim 9, wherein the processing unit is configured to select the model torso and model heart from a plurality of model torsos and model hearts based on at least one characteristic of the patient.
11. The system of claim 10, wherein the processing unit is configured to select the model torso and model heart based on manual or semi-automatic segmentation and registration of medical images taken from the patient.
12. The system of claim 10, wherein the model hearts and the model torsos are constructed by manual or semi-automatic image segmentation of medical images from subjects other than the patient.
13. The system of claim 10, wherein the model torsos are differentiated by at least one of gender or size, and the model hearts are differentiated by at least one of size or disease state.
14. The system of claim 9, wherein the processing unit is configured to calculate a set of epicardial potentials from the projected torso-surface potentials, and determine the set of cardiac activation times based on the set of epicardial potentials.
15. The system of claim 14, wherein the processing unit is configured to assume a source-less volume conductor between the model heart and the model torso in an inverse Cauchy problem for Laplace's equation.
16. The system of claims 14, wherein the processing unit is configured to:
 - assume an analytic relationship between the projected torso-surface potentials and a cardiac transmembrane potential;
 - simulate torso-surface potentials based on the analytic relationship; and
 - identify epicardial potentials that minimize the least square difference between the projected torso-surface potentials and the simulated torso-surface potentials.
17. A computer-readable storage medium comprising instructions that, when executed, cause a processor to:
 - project locations of a plurality of electrodes distributed on a torso of a patient onto a surface of a model torso;
 - receive a torso-surface potential signal sensed by each of the plurality of electrodes;

project each of the torso-surface potential signals onto a respective location on the surface of the model torso based on the determined locations of the electrodes; and determine a set of cardiac activation times for a model heart within the model torso based on the projected torso-surface potential signals and a location of the model heart within the model torso.

* * * * *

专利名称(译)	评估心脏内激活模式		
公开(公告)号	US20150216434A1	公开(公告)日	2015-08-06
申请号	US14/635498	申请日	2015-03-02
[标]申请(专利权)人(译)	美敦力公司		
申请(专利权)人(译)	美敦力公司, INC.		
当前申请(专利权)人(译)	美敦力公司, INC.		
[标]发明人	GHOSH SUBHAM GILLBERG JEFFREY M STADLER ROBERT W		
发明人	GHOSH, SUBHAM GILLBERG, JEFFREY M. STADLER, ROBERT W.		
IPC分类号	A61B5/04 A61B5/00 A61B5/0402		
CPC分类号	A61B5/0402 A61B5/04085 A61N1/0476 A61N1/0484 A61N1/3627 A61B5/742 A61N1/3684 A61B5/0452 A61B5/05 A61B5/02 A61B5/04012 A61N1/3682 A61N1/36842 A61N1/36843 A61B5/044		
优先权	61/482053 2011-05-03 US		
其他公开文献	US9974457		
外部链接	Espacenet USPTO		

摘要(译)

描述了用于评估心脏电不同步的技术。在一些示例中，确定多个躯干表面电位信号中的每一个的激活时间。可以分析或呈现这些激活时间的分散或顺序，以提供患者心脏的电不同步的各种指示。在一些示例中，电极组的电极的位置以及因此感测躯干表面电位信号的位置可以投影在包括模型心脏的模型躯干的表面上。可以解决心电图的逆问题，以基于从患者感测到的躯干表面电位信号确定模型心脏区域的电激活时间。

