



(19) **United States**
(12) **Patent Application Publication**
Halperin et al.

(10) **Pub. No.: US 2014/0350360 A1**
(43) **Pub. Date: Nov. 27, 2014**

(54) **MONITORING A CONDITION OF A SUBJECT**

No. 60/731,934, filed on Nov. 1, 2005, provisional application No. 60/784,799, filed on Mar. 23, 2006, provisional application No. 60/843,672, filed on Sep. 12, 2006.

(71) Applicant: **EarlySense Ltd.**, Ramat Gan (IL)

(72) Inventors: **Avner Halperin**, Ramat Gan (IL);
Arkadi Averboukh, Rehovot (IL)

(21) Appl. No.: **14/454,300**

(22) Filed: **Aug. 7, 2014**

Related U.S. Application Data

(63) Continuation of application No. 14/150,115, filed on Jan. 8, 2014, now Pat. No. 8,840,564, which is a continuation of application No. 13/921,915, filed on Jun. 19, 2013, now Pat. No. 8,679,030, which is a continuation of application No. 13/107,772, filed on May 13, 2011, now Pat. No. 8,491,492, which is a continuation-in-part of application No. 11/782,750, filed on Jul. 25, 2007, now Pat. No. 8,403,865, which is a continuation-in-part of application No. 11/552,872, filed on Oct. 25, 2006, now abandoned, said application No. 14/150,115 is a continuation-in-part of application No. 13/863,293, filed on Apr. 15, 2013, now abandoned, which is a continuation of application No. 11/552,872, filed on Oct. 25, 2006, now abandoned.

(60) Provisional application No. 60/731,934, filed on Nov. 1, 2005, provisional application No. 60/784,799, filed on Mar. 23, 2006, provisional application No. 60/843,672, filed on Sep. 12, 2006, provisional application

Publication Classification

(51) **Int. Cl.**
A61B 5/145 (2006.01)
A61B 5/0205 (2006.01)
A61B 5/11 (2006.01)
A61B 5/00 (2006.01)
(52) **U.S. Cl.**
CPC *A61B 5/14532* (2013.01); *A61B 5/746* (2013.01); *A61B 5/7282* (2013.01); *A61B 5/0205* (2013.01); *A61B 5/7278* (2013.01); *A61B 5/4806* (2013.01); *A61B 5/11* (2013.01); *A61B 5/4839* (2013.01); *A61B 5/6892* (2013.01); *A61B 5/0816* (2013.01)
USPC **600/301**; 600/365

(57) **ABSTRACT**

Apparatus and methods are described, including a method for detecting an onset of a hypoglycemia episode in a subject. One or more critical parameters for hypoglycemia are monitored without contacting the subject. A variation of at least one of the critical parameters is detected, and an alarm is activated when at least one of the critical parameters deviates from an accepted value. Other applications are also described.

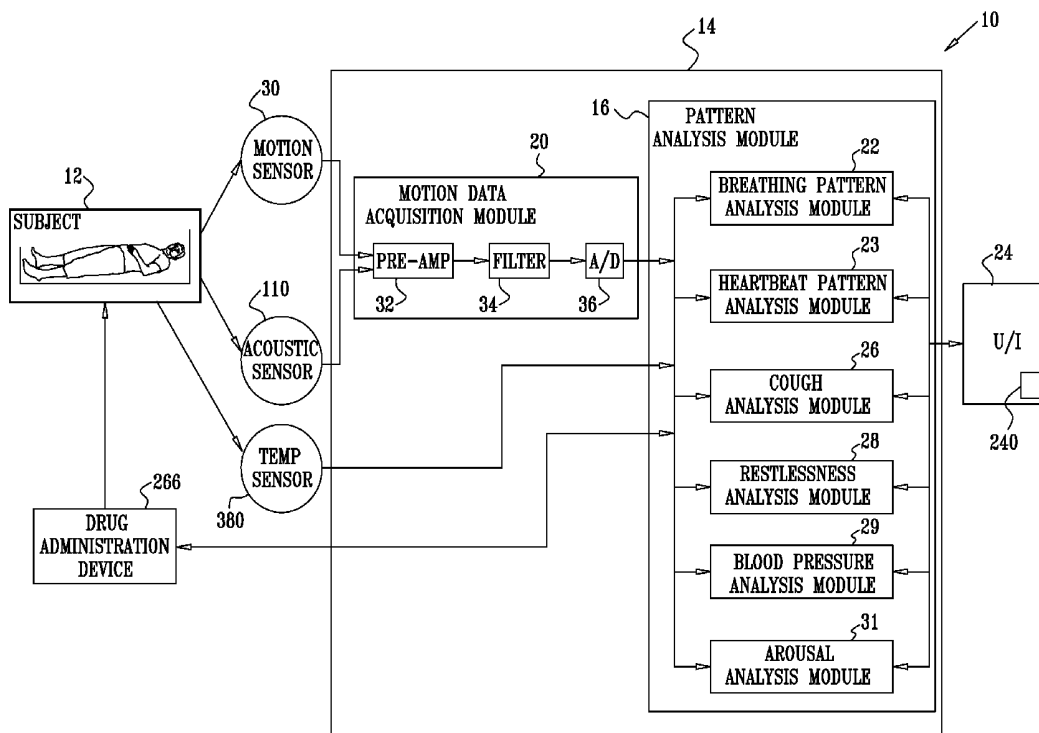
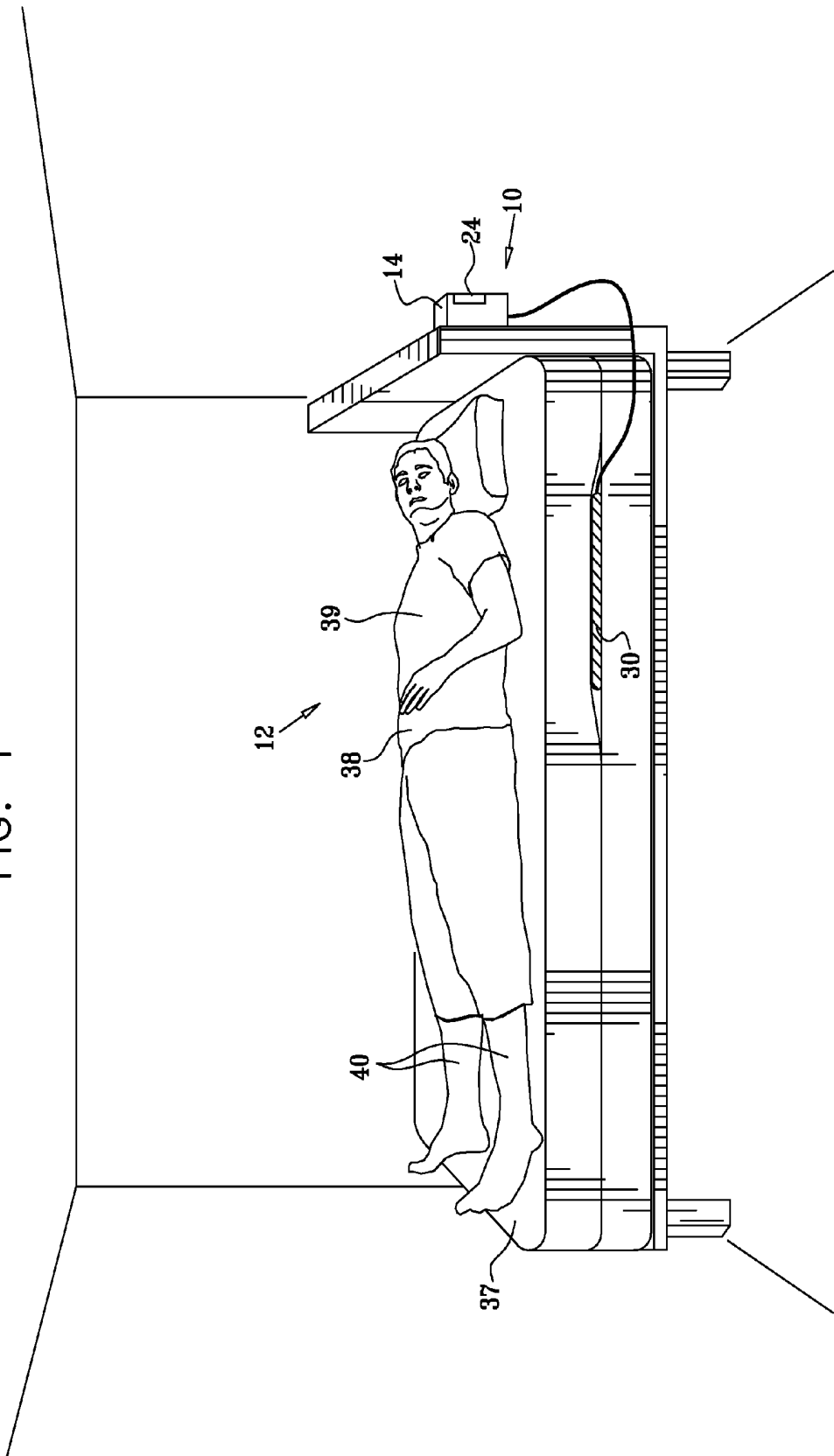

FIG. 1



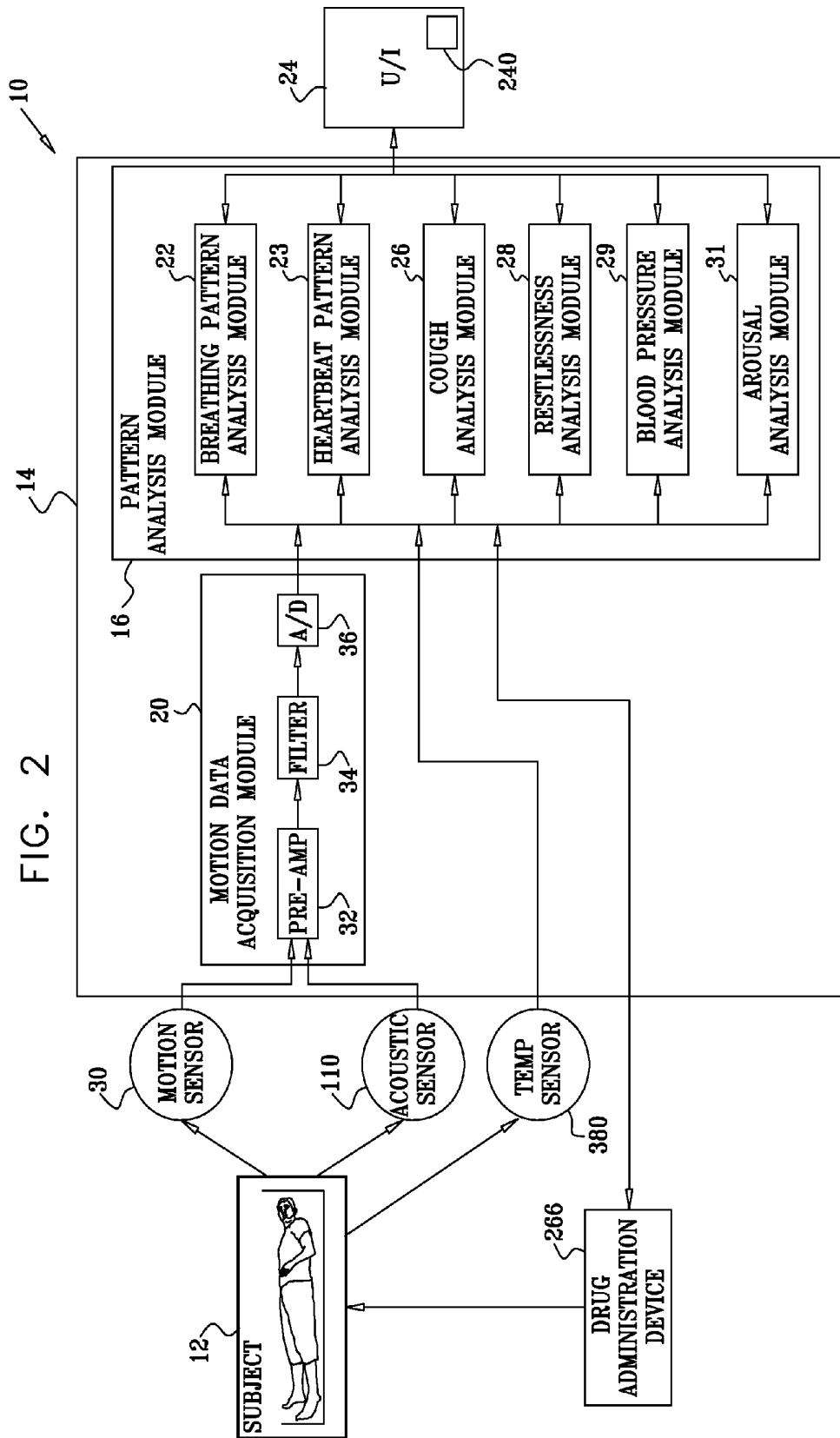

FIG. 3A

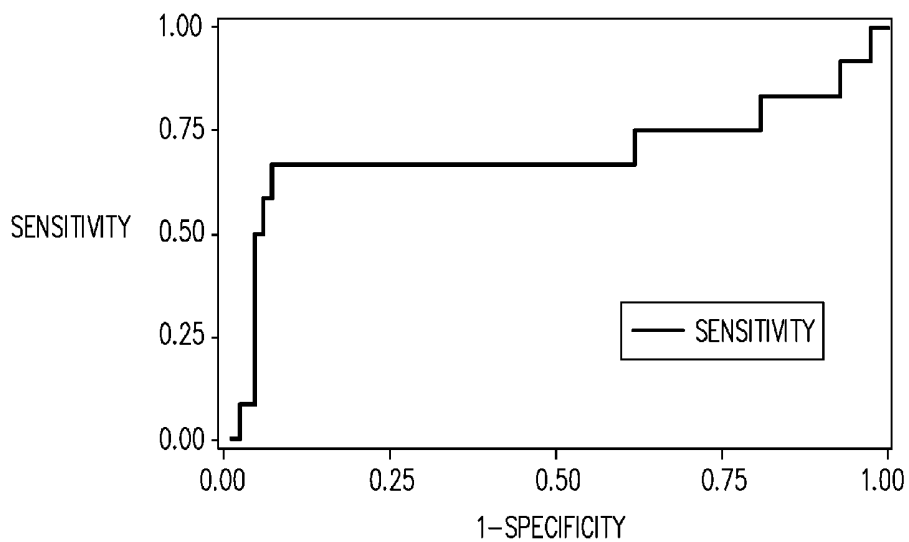

FIG. 3B

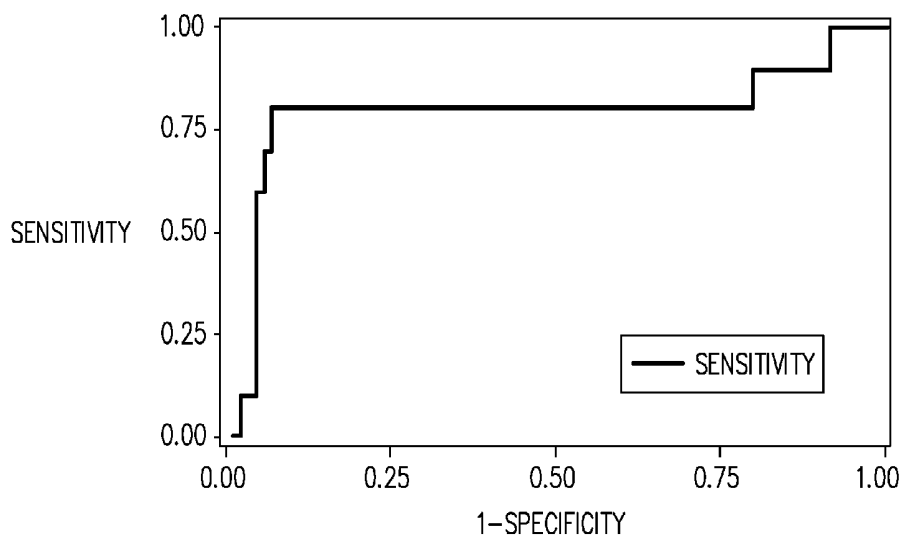

FIG. 3C

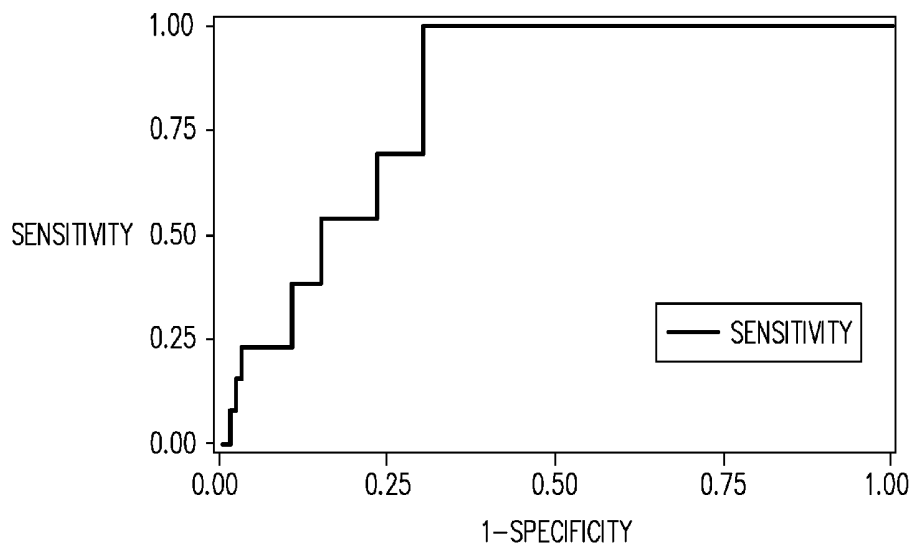
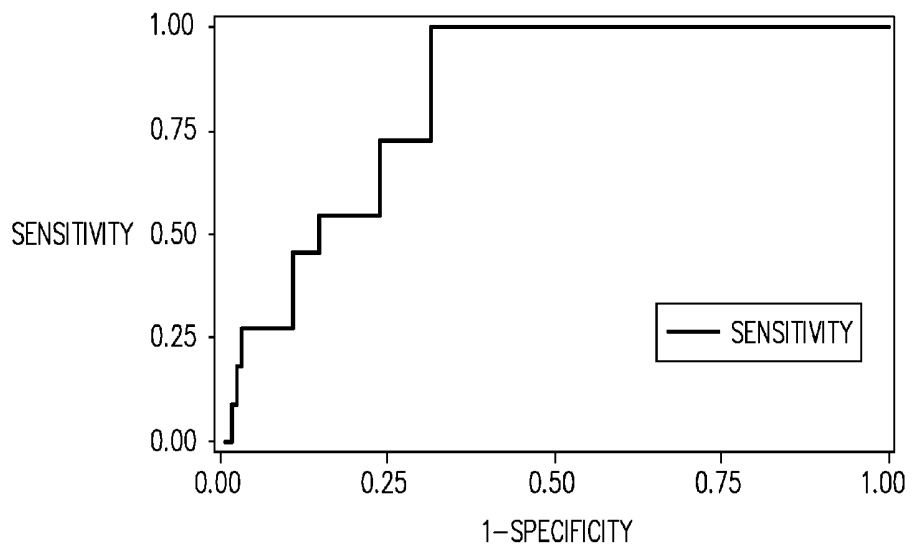

FIG. 3D



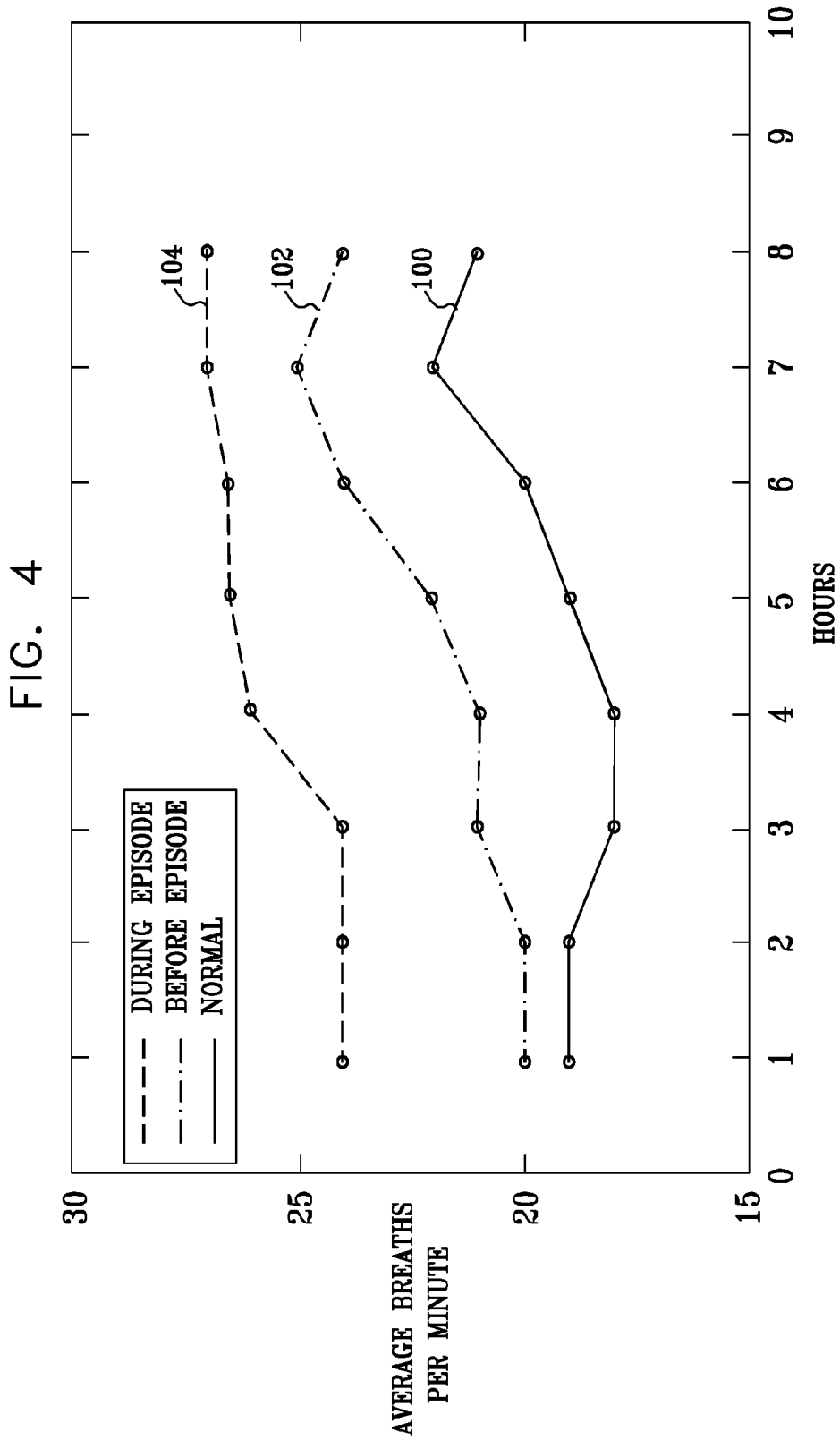

FIG. 5

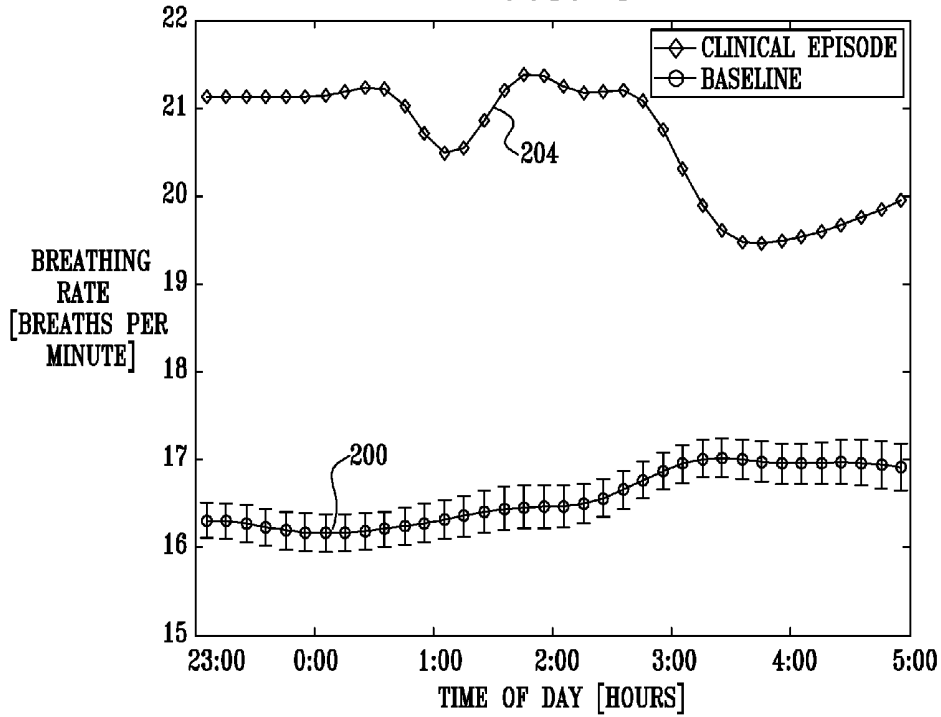

FIG. 6

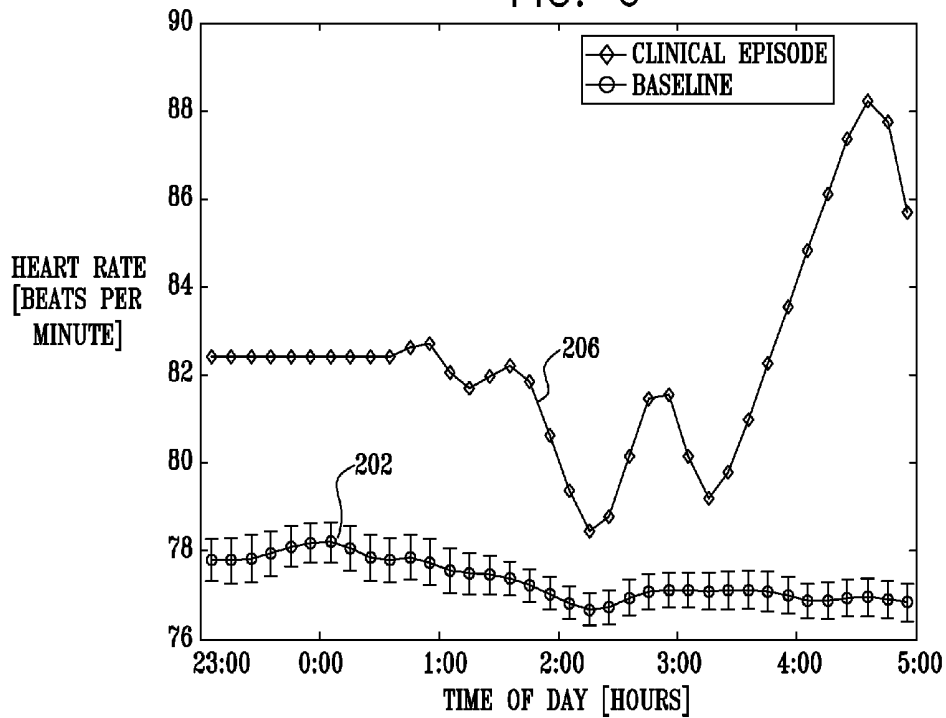
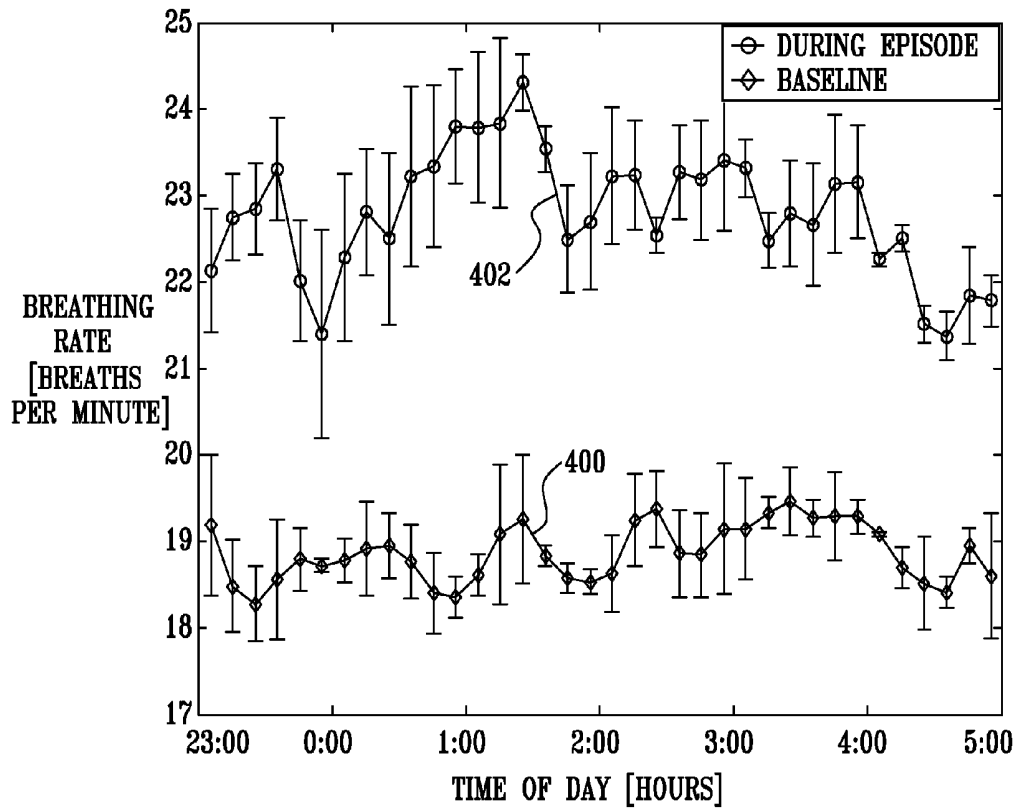
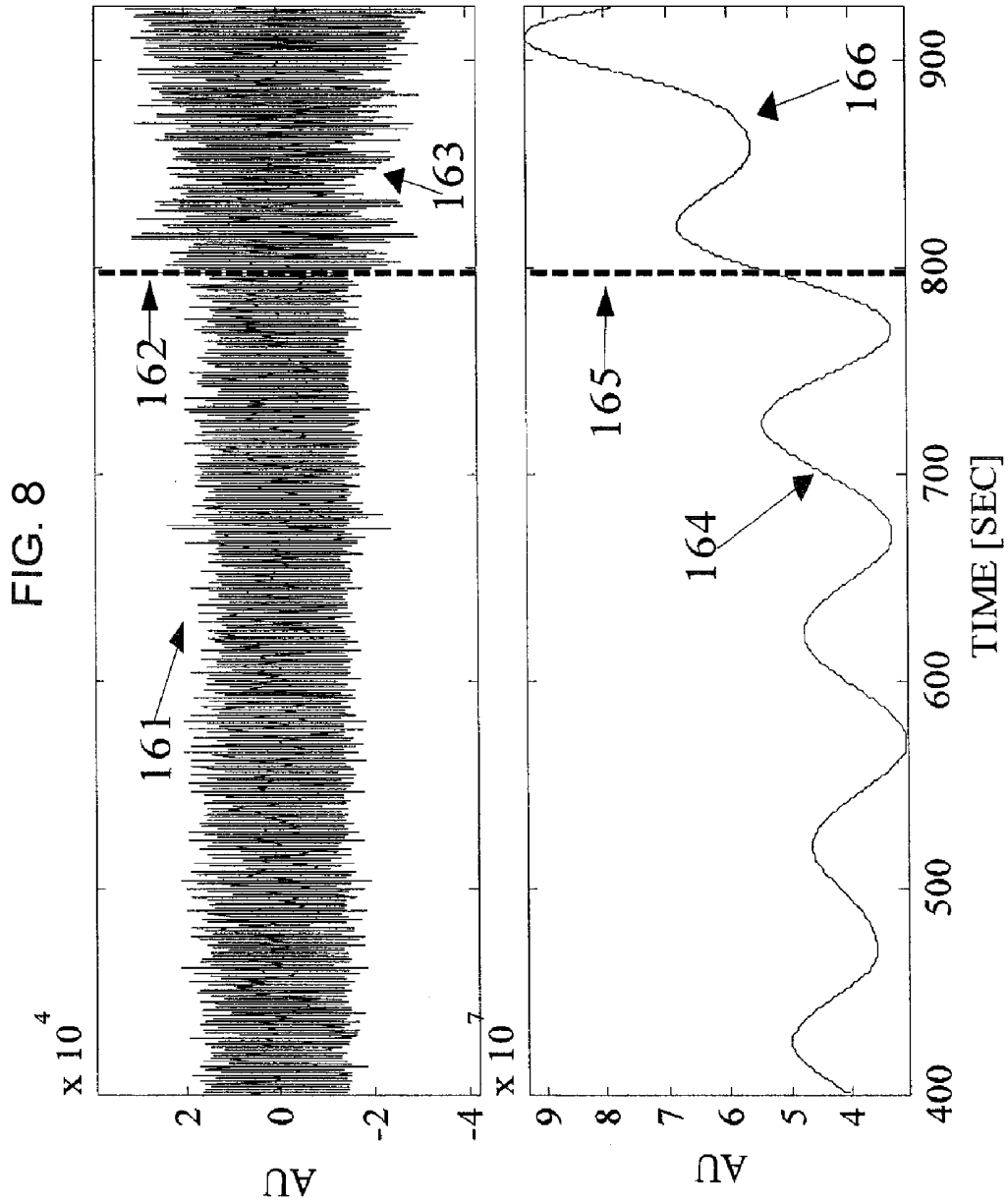

FIG. 7





MONITORING A CONDITION OF A SUBJECT

CROSS-REFERENCES TO RELATED APPLICATIONS

[0001] The present application is a continuation of U.S. patent application Ser. No. 14/150,115 to Pinhas (published as US 2014/0171816), which is:

[0002] (i) a continuation of U.S. patent application Ser. No. 13/921,915 to Shinar (published as US 2013/0281866 and issued as U.S. Pat. No. 8,679,030), filed Jun. 19, 2013, which is a continuation of U.S. patent application Ser. No. 13/107,772 to Shinar (now U.S. Pat. No. 8,491,492), filed May 13, 2011, which:

[0003] is a continuation-in-part of U.S. patent application Ser. No. 11/782,750 to Halperin (now U.S. Pat. No. 8,403,865), filed Jul. 25, 2007; and

[0004] is a continuation-in-part of U.S. patent application Ser. No. 11/552,872 to Pinhas (published as US 2007/0118054), filed Oct. 25, 2006, now abandoned, which claims the benefit of (a) U.S. Provisional Patent Application 60/731,934 to Halperin, filed Nov. 1, 2005, (b) U.S. Provisional Patent Application 60/784,799 to Halperin filed Mar. 23, 2006, and (c) U.S. Provisional Patent Application 60/843,672 to Halperin, filed Sep. 12, 2006; and

[0005] (ii) a continuation-in-part of U.S. patent application Ser. No. 13/863,293 to Lange, published as US 2013/0245502, now abandoned, which is a continuation of U.S. patent application Ser. No. 11/552,872 to Pinhas (published as US 2007/0118054), filed Oct. 25, 2006, now abandoned, which claims the benefit of (a) U.S. Provisional Patent Application 60/731,934 to Halperin, filed Nov. 1, 2005, (b) U.S. Provisional Patent Application 60/784,799 to Halperin filed Mar. 23, 2006, and (c) U.S. Provisional Patent Application 60/843,672 to Halperin, filed Sep. 12, 2006.

[0006] All of the above-mentioned applications are incorporated herein by reference.

FIELD OF EMBODIMENTS OF THE INVENTION

[0007] Some applications of the present invention relate generally to predicting and monitoring physiological conditions. Specifically, some applications relate to methods and apparatus for monitoring a subject by monitoring the subject's respiration rate and/or the subject's heart rate.

BACKGROUND

[0008] Chronic diseases are often expressed by episodic worsening of clinical symptoms. Preventive treatment of chronic diseases reduces the overall dosage of required medication and associated side effects, and lowers mortality and morbidity. Generally, preventive treatment should be initiated or intensified as soon as the earliest clinical symptoms are detected, in order to prevent progression and worsening of the clinical episode and to stop and reverse the pathophysiological process. Therefore, the ability to accurately monitor pre-episodic indicators increases the effectiveness of preventive treatment of chronic diseases.

[0009] Many chronic diseases cause systemic changes in vital signs, such as breathing and heartbeat patterns, through a variety of physiological mechanisms. For example, common respiratory disorders, such as asthma, chronic obstructive pulmonary disease (COPD), and cystic fibrosis (CF), are direct modifiers of breathing and/or heartbeat patterns. Other

chronic diseases, such as diabetes, epilepsy, and certain heart conditions (e.g., congestive heart failure (CHF)), are also known to modify cardiac and breathing activity. In the case of certain heart conditions, such modifications typically occur because of pathophysiologies related to fluid retention and general cardiovascular insufficiency. Other signs such as coughing and sleep restlessness are also known to be of importance in some clinical situations.

[0010] Many chronic diseases induce systemic effects on vital signs. For example, some chronic diseases interfere with normal breathing and cardiac processes during wakefulness and sleep, causing abnormal breathing and heartbeat patterns.

[0011] Breathing and heartbeat patterns may be modified via various direct and indirect physiological mechanisms, resulting in abnormal patterns related to the cause of modification. Some respiratory diseases, such as asthma, and some heart conditions, such as CHF, are direct breathing modifiers. Other metabolic abnormalities, such as hypoglycemia and other neurological pathologies affecting autonomic nervous system activity, are indirect breathing modifiers.

[0012] Asthma is a chronic disease with no known cure. Substantial alleviation of asthma symptoms is possible via preventive therapy, such as the use of bronchodilators and anti-inflammatory agents. Asthma management is aimed at improving the quality of life of asthma patients.

[0013] Monitoring of lung function is viewed as a major factor in determining an appropriate treatment, as well as in patient follow-up. Preferred therapies are often based on aerosol-type medications to minimize systemic side-effects. The efficacy of aerosol type therapy is highly dependent on patient compliance, which is difficult to assess and maintain, further contributing to the importance of lung-function monitoring.

[0014] Asthma episodes usually develop over a period of several days, although they may sometimes seem to appear unexpectedly. The gradual onset of the asthmatic episode provides an opportunity to start countermeasures to stop and reverse the inflammatory process. Early treatment at the pre-episode stage may reduce the clinical episode manifestation considerably, and may even prevent the transition from the pre-clinical stage to a clinical episode altogether.

[0015] Two techniques are generally used for asthma monitoring. The first technique, spirometry, evaluates lung function using a spirometer, an instrument that measures the volume of air inhaled and exhaled by the lungs. Airflow dynamics are measured during a forceful, coordinated inhalation and exhalation effort by the patient into a mouthpiece connected via a tube to the spirometer. A peak-flow meter is a simpler device that is similar to the spirometer, and is used in a similar manner. The second technique evaluates lung function by measuring nitric-oxide concentration using a dedicated nitric-oxide monitor. The patient breathes into a mouthpiece connected via a tube to the monitor.

[0016] Efficient asthma management requires daily monitoring of respiratory function, which is generally impractical, particularly in non-clinical or home environments. Peak-flow meters and nitric-oxide monitors provide a general indication of the status of lung function. However, these monitoring devices do not possess predictive value, and are used as during-episode markers. In addition, peak-flow meters and nitric-oxide monitors require active participation of the patient, which is difficult to obtain from many children and substantially impossible to obtain from infants.

[0017] CHF is a condition in which the heart is weakened and unable to circulate blood to meet the body's needs. The subsequent buildup of fluids in the legs, kidneys, and lungs characterizes the condition as congestive. The weakening may be associated with either the left, right, or both sides of the heart, with different etiologies and treatments associated with each type. In most cases, it is the left side of the heart which fails, so that it is unable to efficiently pump blood to the systemic circulation. The ensuing fluid congestion of the lungs results in changes in respiration, including alterations in rate and/or pattern, accompanied by increased difficulty in breathing and tachypnea.

[0018] Quantification of such abnormal breathing provides a basis for assessing CHF progression. For example, Cheyne-Stokes Respiration (CSR) is a breathing pattern characterized by rhythmic oscillation of tidal volume with regularly recurring periods of alternating apnea and hyperpnea. While CSR may be observed in a number of different pathologies (e.g., encephalitis, cerebral circulatory disturbances, and lesions of the bulbar center of respiration), it has also been recognized as an independent risk factor for worsening heart failure and reduced survival in patients with CHF. In CHF, CSR is associated with frequent awakening that fragments sleep, and with concomitant sympathetic activation, both of which may worsen CHF. Other abnormal breathing patterns may involve periodic breathing, prolonged expiration or inspiration, or gradual changes in respiration rate usually leading to tachypnea.

SUMMARY OF EMBODIMENTS

[0019] For some applications of the present invention, a subject's respiration rate is monitored for a duration of time of greater than two hours. A parameter of the subject's respiration rate over the time duration, such as the median respiration rate, the mean respiration rate, the maximum respiration rate, and/or a pattern of the respiration rate is determined. The parameter is compared to the same parameter as determined on a previous day during a time period that overlaps with (e.g., is substantially the same as, or partially overlaps with) the time period based upon which the parameter of respiration was determined on the present day. For example, the parameter is compared to the same parameter as determined on a previous day for the same time duration and at the same period (e.g., the same time) of the day. For example, the mean respiration rate over a time duration of three hours, between the times of 8 pm and 11 pm on the present day, may be compared with the mean respiration rate over a time duration of three hours between the times of 8 pm and 11 pm on the previous day. In response thereto, the likelihood of the subject subsequently undergoing an adverse clinical event is determined. Typically, it is determined that the subject is likely to undergo an adverse clinical event by determining that the difference between the parameter of respiration (e.g., the mean respiration rate) of the present day and of the previous day is greater than a threshold amount, e.g., by determining that the parameter of respiration of the present day and that of the previous day are substantially different. Typically, in response to determining that the subject is likely to undergo an adverse clinical event, an alert is generated.

[0020] For some applications, the techniques described in the above paragraph with respect to the subject's respiration rate are applied with respect to the subject's heart rate and/or with respect to the subject's respiration rate and the subject's heart rate. For example, it may be determined that the subject

is likely to undergo an adverse clinical event by determining that the difference between a parameter of the subject's cardiac cycle (e.g., the mean heart rate over a time duration of greater than two hours at a given period of the day) of the present day and of a previous day is greater than a threshold amount, e.g., by determining that the parameter of the cardiac cycle of the present day and that of the previous day are substantially different. Or, it may be determined that the subject is likely to undergo an adverse clinical event by determining that the difference between a parameter of the subject's cardiac cycle of the present day and of a previous day is greater than a threshold amount, and the difference between a parameter of the subject's respiration of the present day and of a previous day is greater than a threshold amount.

[0021] For some applications of the present invention, a subject's motion is monitored for a duration of time of greater than two hours. A parameter of the subject's motion, such as total duration that the subject is in motion, or percentage of time that the subject is in motion, over the time duration is determined. The parameter is compared to the same parameter as determined on a previous day during a time period that overlaps with (e.g., is substantially the same as, or partially overlaps with) the time period based upon which the parameter of respiration was determined on the present day. For example, the parameter is compared to the same parameter as determined on a previous day for the same time duration and at the same period (e.g., the same time) of the day. For example, the total time that the subject is in motion, or percentage of time that the subject is in motion over a time duration of three hours, between the times of 8 pm and 11 pm on the present day, may be compared with the total time that the subject is in motion, or percentage of time that the subject is in motion over a time duration of three hours between the times of 8 pm and 11 pm on the previous day. In response thereto, the likelihood of the subject subsequently undergoing an adverse clinical event is determined. Typically, it is determined that the subject is likely to undergo an adverse clinical event by determining that the difference between the parameter of motion of the present day and of the previous day is greater than a threshold amount, e.g., by determining that the parameter of motion of the present day and that of the previous day are substantially different. Typically, in response to determining that the subject is likely to undergo an adverse clinical event, an alert is generated.

[0022] For some applications, the threshold of the cardiac cycle (described hereinabove) is set responsively to a detected respiration rate, and/or responsively to a detected parameter of the subject's motion. Alternatively or additionally, the threshold of the parameter of the subject's respiration (described hereinabove) is set responsively to the detected heart rate, and/or responsively to a detected parameter of the subject's motion. Further alternatively or additionally, the threshold of the parameter of the subject's motion (described hereinabove) is set responsively to the detected heart rate, and/or responsively to the detected respiration rate.

[0023] There is therefore provided, in accordance with some applications of the present invention, apparatus, including:

[0024] a mechanical sensor configured to detect a physiological signal of a subject without contacting or viewing the subject or clothes that the subject is wearing;

[0025] a control unit configured to:

[0026] receive the physiological signal from the sensor over a time duration of at least two hours at a given period of at least one first baseline day,

[0027] determine a physiological parameter of the subject based upon the received physiological signal of the first baseline day;

[0028] receive the physiological signal from the sensor over a time duration of at least two hours at a given period of a second day, the period over which the subject's physiological signal is detected on the second day overlapping with the period over which the subject's physiological signal is detected on the first baseline day;

[0029] determine a physiological parameter of the subject based upon the received physiological signal of the second day;

[0030] compare the physiological parameter based upon the received physiological signal of the second day to the baseline physiological parameter of the subject; and

[0031] generate an alert in response to the comparison; and

[0032] an output unit configured to output the alert.

[0033] For some applications, the physiological sensor is configured to detect the physiological signal of the subject by detecting a respiration rate of the subject.

[0034] For some applications, the physiological sensor is configured to detect the physiological signal of the subject by detecting a heart rate of the subject.

[0035] For some applications, the physiological sensor is configured to detect the physiological signal of the subject by detecting a parameter of motion of the subject.

[0036] There is further provided, in accordance with some applications of the present invention, apparatus, including:

[0037] a sensor configured to detect a respiration signal indicative of a respiration rate of a subject; and

[0038] a control unit configured to:

[0039] receive the detected respiration signal from the sensor over a time duration of at least two hours at a given period of at least one first respiration-rate baseline day;

[0040] determine a baseline parameter of the subject's respiration based upon the received respiration signal of the first respiration-rate baseline day;

[0041] receive the detected respiration signal from the sensor over a time duration of at least two hours at a given period of a second day, the period over which the subject's respiration is detected on the second day overlapping with the period over which the subject's respiration is detected on the first respiration-rate baseline day;

[0042] determine a parameter of the subject's respiration based upon the received respiration signal of the second day;

[0043] compare the parameter of the subject's respiration based upon the received respiration signal of the second day to the baseline parameter of the subject's respiration; and

[0044] generate an alert in response to the comparison; and

[0045] an output unit configured to output the alert.

[0046] For some applications, the control unit is configured to determine the baseline parameter of respiration by determining a baseline respiration pattern based upon the received respiration signal of the first respiration-rate baseline day, and

the control unit is configured to determine the parameter of the subject's respiration based upon the received respiration signal of the second day by determining a respiration pattern based upon the received respiration signal of the second day.

[0047] For some applications:

[0048] the control unit is configured to determine the baseline parameter of respiration by determining a parameter selected from the group consisting of: a mean respiration rate, a maximum respiration rate, and a median respiration rate, based upon the received respiration signal of the first respiration-rate baseline day, and

[0049] the control unit is configured to determine the parameter of the subject's respiration based upon the received respiration signal of the second day by determining a parameter selected from the group consisting of: a mean respiration rate, a maximum respiration rate, and a median respiration rate, based upon the received respiration signal of the second day.

[0050] For some applications, the control unit is configured to:

[0051] receive a heart-rate signal from the sensor indicative of a heart rate of the subject over a time duration of at least two hours at a given period of at least one first heart-rate baseline day;

[0052] determine a baseline parameter of the subject's cardiac cycle based upon the received heart-rate signal of the first heart-rate baseline day;

[0053] receive a heart-rate signal from the sensor indicative of a heart rate of the subject over a time duration of at least two hours at the given period of the second day, the period over which the subject's heart rate is detected on the second day overlapping with the period over which the subject's heart rate is detected on the first heart-rate baseline day;

[0054] determine a parameter of the subject's cardiac cycle based upon the received heart-rate signal of the second day; and

[0055] compare the parameter of the subject's cardiac cycle based upon the received heart-rate signal of the second day to the baseline parameter of the cardiac cycle, and

[0056] generate the alert by generating the alert in response to (a) the comparison of the parameter of the subject's respiration based upon the received respiration signal of the second day to the baseline parameter of the subject's respiration, and (b) the comparison of the parameter of the subject's cardiac cycle based upon the received heart-rate signal of the second day to the baseline parameter of the subject's cardiac cycle.

[0057] For some applications, the control unit is configured to:

[0058] receive a motion signal from the sensor indicative of motion of the subject over a time duration of at least two hours at a given period of at least one first motion-parameter baseline day;

[0059] determine a baseline parameter of the subject's motion based upon the received motion signal of the first motion-parameter baseline day;

[0060] receive a motion signal from the sensor indicative of motion of the subject over a time duration of at least two hours at the given period of the second day, the period over which the subject's motion is detected on the second day overlapping with the period over which the subject's motion is detected on the first motion-parameter baseline day;

[0061] determine a parameter of the subject's motion based upon the received motion signal of the second day; and

[0062] compare the parameter of the subject's motion based upon the received motion signal of the second day to the baseline parameter of motion, and

[0063] generate the alert by generating the alert in response to (a) the comparison of the parameter of the subject's respiration based upon the received respiration signal of the second day to the baseline parameter of the subject's respiration, and (b) the comparison of the parameter of the subject's motion based upon the received motion signal of the second day to the baseline parameter of the subject's motion.

[0064] For some applications, the control unit is configured to compare the parameter of the subject's respiration based upon the received respiration signal of the second day to the baseline parameter of the subject's respiration by determining whether the parameter of the subject's respiration based upon the received respiration signal of the second day differs from the baseline parameter of the subject's respiration by more than a threshold amount.

[0065] For some applications, the control unit is configured to:

[0066] receive a heart-rate signal from the sensor indicative of a heart rate of the subject; and

[0067] set the threshold in response to the detected heart-rate signal.

[0068] For some applications, the control unit is configured to:

[0069] receive a motion signal from the sensor indicative of a motion of the subject; and

[0070] set the threshold in response to the detected motion signal.

[0071] There is additionally provided, in accordance with some applications of the present invention, apparatus, including:

[0072] a sensor configured to detect a heart-rate signal indicative of a heart rate of a subject; and

[0073] a control unit configured to:

[0074] receive the detected heart-rate signal from the sensor over a time duration of at least two hours at a given period of at least one first heart-rate baseline day;

[0075] determine a baseline parameter of the subject's cardiac cycle based upon the received heart-rate signal of the first heart-rate baseline day;

[0076] receive the detected heart-rate signal from the sensor over a time duration of at least two hours at a given period of a second day, the period over which the subject's heart rate is detected on the second day overlapping with the period over which the subject's heart rate is detected on the first heart-rate baseline day;

[0077] determine a parameter of the subject's cardiac cycle based upon the received heart-rate signal of the second day;

[0078] compare the parameter of the subject's cardiac cycle based upon the received heart-rate signal of the second day to the baseline parameter of the subject's cardiac cycle; and

[0079] generate an alert in response to the comparison; and an output unit configured to output the alert.

[0080] For some applications, the control unit is configured to:

[0081] receive a motion signal from the sensor indicative of motion of the subject over a time duration of at least two hours at a given period of at least one first motion-parameter baseline day;

[0082] determine a baseline parameter of the subject's motion based upon the received motion signal of the first motion-parameter baseline day;

[0083] receive a motion signal from the sensor indicative of motion of the subject over a time duration of at least two hours at the given period of the second day, the period over which the subject's motion is detected on the second day overlapping with the period over which the subject's motion is detected on the first motion-parameter baseline day;

[0084] determine a parameter of the subject's motion based upon the received motion signal of the second day; and

[0085] compare the parameter of the subject's motion based upon the received motion signal of the second day to the baseline parameter of motion, and

[0086] generate the alert by generating the alert in response to (a) the comparison of the parameter of the subject's cardiac cycle based upon the received heart-rate signal of the second day to the baseline parameter of the subject's cardiac cycle, and (b) the comparison of the parameter of the subject's motion based upon the received motion signal of the second day to the baseline parameter of the subject's motion.

[0087] For some applications, the control unit is configured to compare the parameter of the subject's cardiac cycle based upon the received heart-rate signal of the second day to the baseline parameter of the subject's cardiac cycle by determining whether the parameter of the subject's cardiac cycle based upon the received heart-rate signal of the second day differs from the baseline parameter of the subject's cardiac cycle by more than a threshold amount.

[0088] For some applications, the control unit is configured to:

[0089] receive a respiration signal from the sensor indicative of a respiration rate of the subject; and

[0090] set the threshold in response to the detected respiration signal.

[0091] For some applications, the control unit is configured to:

[0092] receive a motion signal from the sensor indicative of a motion of the subject; and

[0093] set the threshold in response to the detected motion signal.

[0094] There is further provided, in accordance with some applications of the present invention, apparatus, including:

[0095] a sensor configured to detect a motion signal indicative of motion of a subject; and

[0096] a control unit configured to:

[0097] receive the detected motion signal from the sensor over a time duration of at least two hours at a given period of at least one first motion-parameter baseline day;

[0098] determine a baseline parameter of the subject's motion based upon the received motion signal of the first motion-parameter baseline day;

[0099] receive the detected motion signal from the sensor over a time duration of at least two hours at a given period of a second day, the period over which the subject's motion is detected on the second day overlapping with the period over which the subject's motion is detected on the first motion-parameter baseline day;

[0100] determine a parameter of the subject's motion based upon the received motion signal of the second day;

[0101] compare the parameter of the subject's motion based upon the received motion signal of the second day to the baseline parameter of the subject's motion; and

- [0102] generate an alert in response to the comparison; and an output unit configured to output the alert.
- [0103] For some applications, the control unit is configured to compare the parameter of the subject's motion based upon the received motion signal of the second day to the baseline parameter of the subject's motion by determining whether the parameter of the subject's motion based upon the received motion signal of the second day differs from the baseline parameter of the subject's motion by more than a threshold amount.
- [0104] For some applications, the control unit is configured to:
- [0105] receive a respiration signal from the sensor indicative of a respiration rate of the subject; and
- [0106] set the threshold in response to the detected respiration signal.
- [0107] For some applications, the control unit is configured to:
- [0108] receive a heart-rate signal from the sensor indicative of a heart rate of the subject; and
- [0109] set the threshold in response to the detected heart-rate signal.
- [0110] There is additionally provided, in accordance with some applications of the present invention, a method including:
- [0111] detecting a respiration rate of a subject over a time duration of at least two hours at a given period of at least one first respiration-rate baseline day;
- [0112] determining a baseline parameter of the subject's respiration based upon the detected respiration rate for the first respiration-rate baseline day;
- [0113] detecting a respiration rate of the subject over a time duration of at least two hours at a given period of a second day, the period over which the subject's respiration is detected on the second day overlapping with the period over which the subject's respiration is detected on the first respiration-rate baseline day;
- [0114] determining a parameter of the subject's respiration based upon the detected respiration rate on the second day;
- [0115] comparing the parameter of the subject's respiration based upon the detected respiration rate on the second day to the baseline parameter of the subject's respiration; and
- [0116] generating an alert in response to the comparison.
- [0117] There is further provided, in accordance with some applications of the present invention, a method including:
- [0118] detecting a heart rate of a subject over a time duration of at least two hours at a given period of at least one first heart-rate baseline day;
- [0119] determining a baseline parameter of the subject's cardiac cycle based upon the detected heart rate for the first heart-rate baseline day;
- [0120] detecting a heart rate of the subject over a time duration of at least two hours at a given period of a second day, the period over which the subject's heart rate is detected on the second day overlapping with the period over which the subject's heart rate is detected on the first heart-rate baseline day;
- [0121] determining a parameter of the subject's cardiac cycle based upon the detected heart rate on the second day;
- [0122] comparing the parameter of the subject's cardiac cycle based upon the detected heart rate on the second day to the baseline parameter of the subject's cardiac cycle; and
- [0123] generating an alert in response to the comparison.
- [0124] There is additionally provided, in accordance with some applications of the present invention, a method including:
- [0125] detecting motion of a subject over a time duration of at least two hours at a given period of at least one first motion-parameter baseline day;
- [0126] determining a motion parameter of the subject's respiration based upon the detected motion for the first motion-parameter baseline day;
- [0127] detecting motion of the subject over a time duration of at least two hours at a given period of a second day, the period over which the subject's motion is detected on the second day overlapping with the period over which the subject's motion is detected on the first motion-parameter baseline day;
- [0128] determining a parameter of the subject's motion based upon the motion detected on the second day;
- [0129] comparing the parameter of the subject's motion based upon the motion detected on the second day to the baseline parameter of the subject's motion; and
- [0130] generating an alert in response to the comparison.
- [0131] There is further provided, in accordance with some applications of the present invention, a method including:
- [0132] detecting a physiological signal of a subject over a time duration of at least two hours at a given period of at least one first baseline day, without contacting or viewing the subject or clothes that the subject is wearing;
- [0133] determining a physiological parameter of the subject based upon the detected physiological signal for the first baseline day;
- [0134] detecting the physiological signal of the subject over a time duration of at least two hours at a given period of a second day, the period over which the subject's physiological signal is detected on the second day overlapping with the period over which the physiological signal is detected on the first baseline day;
- [0135] determining a physiological parameter of the subject based upon the detected physiological signal on the second day;
- [0136] comparing the physiological parameter based upon the detected physiological signal on the second day to the baseline physiological parameter of the subject; and
- [0137] generating an alert in response to the comparison.
- [0138] Other embodiments of the invention include methods and systems for identifying hypoglycemia in a patient and methods for detecting and treating hypoglycemia in a patient automatically, for example, by using a non-contact sensor. These methods and systems may include one or more alarms that advise the patient or the healthcare provider when a hypoglycemic episode is about to occur or is occurring. The methods and systems may include a motion acquisition module, a pattern analysis module, and an output module, as discussed below.
- [0139] Another embodiment of the invention is method for detecting an onset of a hypoglycemia episode in a subject, the method comprising monitoring one or more critical parameters for hypoglycemia, for example, without contacting the subject; detecting a variation of at least one of the critical parameters; and activating an alarm when at least one of the critical parameters deviates from an accepted value. In one aspect, the critical parameters comprise at least one of respiration rate, heart rate, occurrence of palpitations, restlessness, and tremor.

[0140] Another embodiment of the invention is an apparatus for detecting an onset of a hypoglycemia episode in a subject, the apparatus comprising at least one sensor adapted to monitor one or more critical parameters for hypoglycemia, for example, without contacting or viewing the subject; an analyzer adapted to detect a variation of at least one of the critical parameters; and means for activating an alarm when at least one of the critical parameters deviates from an accepted value.

[0141] The present invention will be more fully understood from the following detailed description of embodiments thereof, taken together with the drawings, in which:

BRIEF DESCRIPTION OF THE DRAWINGS

[0142] FIG. 1 is a schematic illustration of a system for monitoring a chronic medical condition of a subject, in accordance with some applications of the present invention;

[0143] FIG. 2 is a schematic block diagram illustrating components of a control unit of the system of FIG. 1, in accordance with some applications of the present invention;

[0144] FIGS. 3A-D are graphs showing the results of experiments conducted, in accordance with some applications of the present invention;

[0145] FIG. 4 is a graph illustrating breathing rate patterns of a chronic asthma patient, which is the same as FIG. 4 of U.S. Pat. No. 7,077,810 to Lange, which is incorporated herein by reference;

[0146] FIGS. 5 and 6 are graphs of exemplary baseline and measured breathing rate and heart rate nighttime patterns, respectively, which are generally similar to FIGS. 6 and 7 of U.S. Pat. No. 7,314,451 to Halperin, which is incorporated herein by reference;

[0147] FIG. 7 is a graph of baseline and breathing rate nighttime patterns, respectively, which is the same as FIG. 23 of U.S. Pat. No. 7,314,451 to Halperin; and

[0148] FIG. 8 is a graph illustrating the signal measured by an embodiment of the present invention monitoring a human subject during an experiment of voluntarily induced increased tremor and the corresponding time dependent total spectrum power at the frequency band of 3-9 Hz.

DETAILED DESCRIPTION OF EMBODIMENTS

[0149] Reference is made to FIG. 1, which is a schematic illustration of a system 10 for monitoring a chronic medical condition of a subject 12, in accordance with some applications of the present invention. System 10 typically comprises a mechanical sensor 30 (e.g., a motion sensor), a control unit 14, and a user interface 24. For some applications, user interface 24 is integrated into control unit 14, as shown in the figure, while for other applications, the user interface and control unit are separate units. For some applications, motion sensor 30 is integrated into control unit 14, in which case user interface 24 is either also integrated into control unit 14 or remote from control unit 14.

[0150] FIG. 2 is a schematic block diagram illustrating components of control unit 14, in accordance with some applications of the present invention. Control unit 14 typically comprises a motion data acquisition module 20 and a pattern analysis module 16. Pattern analysis module 16 typically comprises one or more of the following modules: a breathing pattern analysis module 22, a heartbeat pattern analysis module 23, a cough analysis module 26, a restlessness analysis module 28, a blood pressure analysis module

29, and an arousal analysis module 31. For some applications, two or more of analysis modules 20, 22, 23, 26, 28, 29, and 31 are packaged in a single housing. For other applications, the modules are packaged separately (for example, so as to enable remote analysis by one or more of the pattern analysis modules of breathing signals acquired locally by data acquisition module 20). For some applications, user interface 24 comprises a dedicated display unit such as an LCD or CRT monitor. Alternatively or additionally, user interface 24 includes a communication line for relaying the raw and/or processed data to a remote site for further analysis and/or interpretation.

[0151] For some applications of the present invention, data acquisition module 20 is adapted to non-invasively monitor breathing and heartbeat patterns of subject 12. Breathing pattern analysis module 22 and heartbeat pattern analysis module 23 are adapted to analyze the respective patterns in order to (a) predict an approaching clinical event, such as an asthma attack or heart condition-related lung fluid buildup, and/or (b) monitor the severity and progression of a clinical event as it occurs. For some applications, breathing pattern analysis module 22 and heartbeat pattern analysis module 23 are adapted to analyze the respective patterns in order to determine a likelihood of an approaching adverse clinical event without necessarily identifying the nature of the event. User interface 24 is adapted to notify subject 12 and/or a healthcare worker of the predicted or occurring event. Prediction of an approaching clinical event facilitates early preventive treatment, which generally reduces the required dosage of medication, and/or lowers mortality and morbidity. When treating asthma, such a reduced dosage generally minimizes the side-effects associated with high dosages typically required to reverse the inflammatory condition once the event has begun.

[0152] For some applications of the present invention, pattern analysis module 16 combines parameter data generated from two or more of analysis modules 20, 22, 23, 26, 28, 29, and analyzes the combined data in order to predict and/or monitor a clinical event. For some applications, pattern analysis module 16 derives a score for each parameter based on the parameter's deviation from baseline values (either for the specific patient or based on population averages). Pattern analysis module 16 combines the scores, such as by taking an average, maximum, standard deviation, or other function of the scores. The combined score is compared to one or more threshold values (which may be predetermined) to determine whether an event is predicted, currently occurring, or neither predicted nor occurring, and/or to monitor the severity and progression of an occurring event. For some applications, pattern analysis module 16 learns the criteria and/or functions for combining the individual parameter scores for the specific patient or patient group based on personal history. For example, pattern analysis module 16 may perform such learning by analyzing parameters measured prior to previous clinical events.

[0153] Although system 10 may monitor breathing and heartbeat patterns at any time, for some conditions it is generally most effective to monitor such patterns during sleep at night. When the subject is awake, physical and mental activities unrelated to the monitored condition often affect breathing and heartbeat patterns. Such unrelated activities generally have less influence during most night sleep. For some applications, system 10 monitors and records patterns throughout all or a large portion of a night. The resulting data set gener-

ally encompasses typical long-term respiratory and heartbeat patterns, and facilitates comprehensive analysis. Additionally, such a large data set enables rejection of segments contaminated with movement or other artifacts, while retaining sufficient data for a statistically significant analysis.

[0154] Reference is again made to FIG. 2. Data acquisition module 20 typically comprises circuitry for processing the raw motion signal generated by motion sensor 30, such as at least one pre-amplifier 32, at least one filter 34, and an analog-to-digital (A/D) converter 36. Filter 34 typically comprises a band-pass filter or a low-pass filter, serving as an anti-aliasing filter with a cut-off frequency of less than one half of the sampling rate. The low-passed data is typically digitized at a sampling rate of at least 10 Hz and stored in memory. For example, the anti-aliasing filter cut-off may be set to 5 Hz and the sampling rate set to 40 Hz.

[0155] Reference is again made to FIG. 1. Typically, motion sensor 30 detects one or more physiological signal of the subject without contacting or viewing the subject or clothes that the subject is wearing. For some applications of the present invention, motion sensor 30 comprises a pressure gauge (e.g., a piezoelectric sensor) or a strain gauge (e.g., a silicon or other semiconductor strain gauge, or a metallic strain gauge), which is typically adapted to be installed in, on, or under a reclining surface 37 upon which the subject lies, e.g., sleeps, and to sense breathing- and heartbeat-related motion of the subject. "Pressure gauge," as used in the claims, includes, but is not limited to, all of the gauges mentioned in the previous sentence. Typically, reclining surface 37 comprises a mattress, a mattress covering, a sheet, a mattress pad, and/or a mattress cover. For some applications, motion sensor 30 is integrated into reclining surface 37, e.g., into a mattress, and the motion sensor and reclining surface are provided together as an integrated unit. For some applications, motion sensor 30 is adapted to be installed in, on, or under reclining surface 37 in a vicinity of an abdomen 38 or chest 39 of subject 12. Alternatively or additionally, motion sensor 30 is installed in, on, or under reclining surface 37 in a vicinity of a portion of subject 12 anatomically below a waist of the subject, such as in a vicinity of legs 40 of the subject. For some applications, such positioning provides a clearer pulse signal than positioning the sensor in a vicinity of abdomen 38 or chest 39 of the subject. For some applications, motion sensor 30 comprises a fiber optic sensor, for example, as described by Butter and Hocker in *Applied Optics* 17: 2867-2869 (Sep. 15, 1978).

[0156] For some applications, the pressure or strain gauge is encapsulated in a rigid compartment, which typically has a surface area of at least 10 cm², and a thickness of less than 5 mm. The gauge output is channeled to an electronic amplifier, such as a charge amplifier typically used with piezoelectric accelerometers and capacitive transducers to condition the extremely high output impedance of the transducer to a low impedance voltage suitable for transmission over long cables. The strain gauge and electronic amplifier translate the mechanical vibrations into electrical signals. Alternatively, the strain gauge output is amplified using a Wheatstone bridge and an amplifier such as Analog Device Module Numbers 3B16, for a minimal bandwidth, or 3B18, for a wider bandwidth (National Instruments Corporation, Austin, Tex., USA).

[0157] For some applications of the present invention, motion sensor 30 comprises a grid of multiple pressure or strain gauge sensors, adapted to be installed in, on, or under

reclining surface 37. The use of such a grid, rather than a single gauge, may improve breathing and heartbeat signal reception.

[0158] Breathing pattern analysis module 22 is adapted to extract breathing patterns from the motion data, and heartbeat pattern analysis module 23 is adapted to extract heartbeat patterns from the motion data. Alternatively or additionally, system 10 comprises another type of sensor, such as an acoustic or air-flow sensor, attached or directed at the subject's face, neck, chest and/or back.

[0159] For some applications of the present invention, the subject's respiration rate is monitored for a duration of time of greater than two hours (e.g., greater than three hours, greater than four hours, greater than five hours, or greater than six hours). Breathing pattern analysis module 22 determines a parameter of the subject's respiration rate over the time duration, such as the median respiration rate, the mean respiration rate, the maximum respiration rate, and/or a respiration rate pattern. Module 22 compares the determined parameter to the same parameter as determined on a previous day during a time period that overlaps with the time period based upon which the parameter of respiration was determined on the present day. For example, the parameter is compared to the same parameter as determined on a previous day for the same time duration and at the same period (e.g., the same time) of the day.

[0160] For example, the mean respiration rate over a time duration of three hours, between the times of 8 pm and 11 pm on the present day, may be compared with the mean respiration rate over a time duration of three hours between the times of 8 pm and 11 pm on the previous day. In response thereto, the likelihood of the subject subsequently undergoing an adverse clinical event is determined. Typically, it is determined that the subject is likely to undergo an adverse clinical event by determining that the difference between the parameter of respiration (e.g., the mean respiration rate) of the present day and of the previous day is greater than a threshold amount. Typically, in response to determining that the subject is likely to undergo an adverse clinical event, an alert is generated by user interface 24.

[0161] For some applications, the period of to the day which is compared to the same period of the previous day is a time period, e.g., between 8 pm and 11 pm, as described hereinabove. Alternatively, the period may be defined with respect to the subject's circadian clock, e.g., the period may be the first three hours of the subject's sleep, or from the beginning of the second hour of the subject's sleep to the end of the fifth hour of the subject's sleep.

[0162] For some applications, heartbeat pattern analysis module 23 applies generally similar analysis to the subject's heart rate to that described hereinabove with respect to the breathing pattern analysis module 22. For example, module 23 may determine that the subject is likely to undergo an adverse clinical event by determining that the difference between a parameter of the subject's cardiac cycle (e.g., the mean heart rate over a time duration of greater than two hours at a given period of the day) on the present day and that of a previous day is greater than a threshold amount. For some applications, control unit 24 determines that the subject is likely to undergo an adverse clinical event by determining that the difference between a parameter of the subject's cardiac cycle on the present day and that of a previous day is greater than a threshold amount, and the difference between a

parameter of the subject's respiration on the present day and that of the previous day is greater than a threshold amount.

[0163] As described hereinabove, for some applications, breathing pattern analysis module 22 and heartbeat pattern analysis module 23 are adapted to analyze the respective patterns in order to determine a likelihood of an approaching adverse clinical event without necessarily identifying the nature of the event. Thus, for some applications, in response to determining that the subject is likely to undergo an adverse clinical event, the user interface generates a generic alert signal, in order to indicate to a healthcare professional that an adverse clinical event is imminent.

[0164] For some applications, system 10 applies generally similar analysis to a different physiological parameter of the subject to that described hereinabove with respect to the breathing pattern analysis module 22. For example, the system may apply the analysis to a parameter of the subject's motion, such as the total time that the subject is in motion, or percentage of time that the subject is in motion over a given time duration.

[0165] Reference is now made to FIGS. 3A-D, which are graphs showing the results of experiments conducted, in accordance with some applications of the present invention. EarlySense Ltd. (Israel) manufactures the EverOn™ system, which is a contact-less piezoelectric sensor placed under a subject's mattress that provides continuous measurement of heart rate and respiration rate of the subject, generally in accordance with the techniques described hereinabove.

[0166] A non-interventional study was conducted in two internal medicine departments (Sheba Medical Center and Meir Medical Center, both in Israel). Patients who were admitted due to an acute respiratory condition were enrolled on the study. Patients were monitored by the EverOn™ sensor and followed for major clinical episodes. A major clinical event was defined as death, transfer to ICU, or intubation and mechanical ventilation on the floors. Out of 149 patients included in the study, 96 patients had a length of stay that allowed at least one comparable time window. Ten major clinical events were recorded for these patients. Retrospective analysis of continuous respiratory and heart signal recording was performed. The median respiration rate and heart rate over 6-hour time durations (00-06, 06-12, 12-18, and 18-24) were compared to the median respiration rate and heart rate over a corresponding 6-hour time duration on the previous day. Similarly, the maximum respiration rate and heart rate over 6-hour time durations (00-06, 06-12, 12-18, and 18-24) were compared to the maximum respiration rate and heart rate over a corresponding 6-hour time duration on the previous day. Retrospective receiver operating characteristic (ROC) curve analysis was applied to the results to determine the sensitivity, specificity, positive predictive value, and negative predictive value of using respective thresholds (i.e., thresholds for the difference between median or maximum respiration rate or heart rate and those of the previous day) for determining the likelihood of a subject undergoing (a) any adverse clinical event, i.e., either a major or a moderate clinical event (such as a non-major respiratory event requiring immediate intervention, e.g., bilevel positive airway pressure (BIPAP) or continuous positive airway pressure (CPAP)), or (b) a major clinical event.

[0167] Table 1 (shown below) shows the results of the ROC curve analysis of respective combinations of median heart rate and respiration rate thresholds (i.e., thresholds for the difference between median heart rate and respiration rate and

those of the previous day) with respect to determining the likelihood of a subject undergoing any adverse clinical event, i.e., either a major or a moderate clinical event.

TABLE 1

Threshold Heart rate (beats per minute) - Respiration rate (breaths per minute)	Sensitivity	Specificity	PPV	NPV
14-3	67	82	35	95
14-4	67	82	35	95
14-5	67	86	40	95
14-6	58	89	44	94
16-3	67	87	42	95
16-4	67	87	42	95
16-5	67	89	47	95
16-6	58	93	54	94
18-3	67	89	47	95
18-4	67	89	47	95
18-5	67	90	50	95
18-6	58	94	58	94
20-3	67	94	62	95
20-4	67	94	62	95
20-5	67	95	67	95
20-6	58	98	78	94
22-3	67	94	62	95
22-4	67	94	62	95
22-5	67	95	67	95
22-6	58	98	78	94

[0168] Table 2 (shown below) shows the results of the ROC curve analysis of respective combinations of median heart rate and respiration rate (i.e., thresholds for the difference between median heart rate and respiration rate and those of the previous day) thresholds with respect to determining the likelihood of a subject undergoing a major clinical event.

TABLE 2

Threshold (Heart rate (beats per minute) - Respiration rate (breaths per minute))	Sensitivity	Specificity	PPV	NPV
-3	80	83	35	97
14-4	80	83	35	97
14-5	80	86	40	97
14-6	70	90	44	96
16-3	80	87	42	97
16-4	80	87	42	97
16-5	80	90	47	97
16-6	70	93	54	96
18-3	80	90	47	97
18-4	80	90	47	97
18-5	80	91	50	98
18-6	70	94	58	96
20-3	80	94	62	98
20-4	80	94	62	98
20-5	80	95	67	98
20-6	70	98	78	97
22-3	80	94	62	98
22-4	80	94	62	98
22-5	80	95	67	98
22-6	70	98	78	97

[0169] It is noted with respect to Tables 1 and 2 that the greatest sum of sensitivity and specificity is for thresholds of 20 or 22 for median heart rate in combination with a threshold of 5 for median respiration rate, both for predicting all adverse

clinical events (i.e., major and minor adverse clinical events), and for predicting major clinical events.

[0170] Thus, for some applications of the present invention, a subject's heart rate and respiration rate are monitored. The median (or mean, or maximum) heart rate and respiration rate over a time duration of more than two hours and less than eight hours (e.g., greater than three hours, greater than four hours, greater than five hours, or greater than six hours) is determined and is compared to the median (or mean, or maximum) heart rate and respiration rate over a similar time duration at a similar period of the day (e.g., at the same time of day) on at least one previous day (e.g., the previous day). In response to determining (a) that the median (or mean, or maximum) heart rate on the present day differs from that of the previous day by a threshold amount of more than 15 beats per minute, e.g., more than 18 beats per minute, and (b) that the median (or mean, or maximum) respiration rate of the present day differs from that of the previous day by a threshold amount of more than 3 breaths per minute, e.g., more than 4 breaths per minute, then an alert is generated in order to indicate that an adverse clinical event is likely to occur.

[0171] Table 3 (shown below) shows the results of the ROC curve analysis of respective maximum heart rate thresholds (i.e., thresholds for the difference between the maximum heart rate and that of the previous day) with respect to determining the likelihood of a subject undergoing a major or a moderate clinical event.

TABLE 3

Heart rate threshold (beats per minute)	Sensitivity	Specificity	Sum of Sensitivity and Specificity
0.00	1.00	0.00	1.00
0.25	1.00	0.01	1.01
1.00	1.00	0.02	1.02
3.00	0.92	0.07	0.99
4.00	0.83	0.11	0.94
4.50	0.83	0.17	1.00
5.00	0.83	0.19	1.02
6.00	0.75	0.25	1.00
7.00	0.75	0.32	1.07
8.00	0.75	0.38	1.13
8.50	0.67	0.46	1.13
9.00	0.67	0.48	1.14
10.00	0.67	0.54	1.20
11.00	0.67	0.62	1.29
11.50	0.67	0.70	1.37
12.00	0.67	0.71	1.38
13.00	0.67	0.75	1.42
13.50	0.67	0.79	1.45
14.00	0.67	0.80	1.46
15.00	0.67	0.82	1.49
16.00	0.67	0.85	1.51
17.00	0.67	0.86	1.52
18.00	0.67	0.87	1.54
19.00	0.67	0.89	1.56
20.00	0.67	0.90	1.57
21.00	0.67	0.92	1.58
22.00	0.67	0.93	1.60
22.75	0.58	0.93	1.51
25.00	0.58	0.94	1.52
27.00	0.50	0.95	1.45
28.00	0.42	0.95	1.37
29.00	0.33	0.95	1.29
30.75	0.17	0.95	1.12
32.00	0.08	0.95	1.04
33.00	0.08	0.96	1.05

TABLE 3-continued

Heart rate threshold (beats per minute)	Sensitivity	Specificity	Sum of Sensitivity and Specificity
34.00	0.08	0.98	1.06
53.00	0.00	0.98	0.98
56.00	0.00	0.99	0.99

[0172] It is noted with respect to Table 3 that the greatest sum of sensitivity and specificity is for a heart rate threshold of 22 beats per minute, for predicting major and moderate adverse clinical events. FIG. 3A shows the ROC curve for a heart rate threshold of 22 with respect to predicting a likelihood of either a major or a moderate adverse clinical event. The area under the curve is 0.70 with a standard deviation of 0.11 and a p-value of 0.026.

[0173] Table 4 (shown below) shows the results of the ROC curve analysis of respective maximum heart rate thresholds (i.e., thresholds for the difference between the maximum heart rate and that of the previous day) with respect to determining the likelihood of a subject undergoing a major clinical event.

TABLE 4

Heart rate threshold (beats per minute)	Sensitivity	Specificity	Sum of Sensitivity and Specificity
0.00	1.00	0.00	1.00
0.25	1.00	0.01	1.01
1.00	1.00	0.02	1.02
3.00	1.00	0.08	1.08
4.00	0.90	0.12	1.02
4.50	0.90	0.17	1.07
5.00	0.90	0.20	1.10
6.00	0.80	0.26	1.06
7.00	0.80	0.33	1.13
8.00	0.80	0.38	1.18
8.50	0.80	0.48	1.28
9.00	0.80	0.49	1.29
10.00	0.80	0.55	1.35
11.00	0.80	0.63	1.43
11.50	0.80	0.71	1.51
12.00	0.80	0.72	1.52
13.00	0.80	0.76	1.56
13.50	0.80	0.79	1.59
14.00	0.80	0.80	1.60
15.00	0.80	0.83	1.63
16.00	0.80	0.85	1.65
17.00	0.80	0.86	1.66
18.00	0.80	0.87	1.67
19.00	0.80	0.90	1.70
20.00	0.80	0.91	1.71
21.00	0.80	0.92	1.72
22.00	0.80	0.93	1.73
22.75	0.70	0.93	1.63
25.00	0.70	0.94	1.64
27.00	0.60	0.95	1.55
28.00	0.50	0.95	1.45
29.00	0.40	0.95	1.35
30.75	0.20	0.95	1.15
32.00	0.10	0.95	1.05
33.00	0.10	0.97	1.07
34.00	0.10	0.98	1.08
53.00	0.00	0.98	0.98
56.00	0.00	0.99	0.99

[0174] It is noted with respect to Table 4 that the greatest sum of sensitivity and specificity is for a heart rate threshold

of 22 beats per minute for predicting major adverse clinical events. FIG. 3B shows the ROC curve for a heart rate threshold of 22 with respect to predicting a likelihood of a major adverse clinical event. The area under the curve is 0.79 with a standard deviation of 0.11 and a p-value of 0.0024.

[0175] In general, in accordance with the indications provided by the data in Tables 3 and 4 and in FIGS. 3A and 3B, a subject's heart rate is monitored. The median (or mean, or maximum) heart rate over a time duration of more than two hours and less than eight hours (e.g., greater than three hours, greater than four hours, greater than five hours, or greater than six hours) is determined and is compared to the median (or mean, or maximum) heart rate over a similar time duration at a similar period of the day (e.g., at the same time of day) on at least one previous day (e.g., the previous day). In response to determining (a) that the median (or mean, or maximum) heart rate of the present day differs from that of the previous day by a threshold amount of more than 15 beats per minute (e.g., more than 18 beats per minute, e.g., more than 20 beats per minute), and/or less than 30 beats per minute, then an alert is generated in order to indicate that an adverse clinical event is likely to occur.

[0176] Table 5 (shown below) shows the results of the ROC curve analysis of respective maximum respiration rate thresholds (i.e., thresholds for the difference between the maximum respiration rate and that of the previous day), with respect to determining the likelihood of a subject undergoing a major or a moderate clinical event.

TABLE 5

Respiration rate threshold (breaths per minute)	Sensitivity	Specificity	Sum of Sensitivity and Specificity
0.00	1.00	0.00	1.00
0.50	1.00	0.05	1.05
1.00	1.00	0.06	1.06
1.50	1.00	0.24	1.24
2.00	1.00	0.26	1.26
3.00	1.00	0.43	1.43
3.50	1.00	0.58	1.58
4.00	1.00	0.59	1.59
5.00	1.00	0.70	1.70
6.00	0.69	0.76	1.46
6.50	0.54	0.83	1.37
6.75	0.54	0.85	1.39
7.00	0.46	0.85	1.31
7.50	0.38	0.89	1.28
8.00	0.31	0.89	1.20
9.00	0.23	0.92	1.15
10.00	0.23	0.92	1.16
12.00	0.23	0.93	1.16
16.00	0.23	0.97	1.20
18.00	0.15	0.97	1.13
19.00	0.08	0.98	1.06
24.00	0.00	0.98	0.98
35.00	0.00	0.99	0.99

[0177] It is noted with respect to Table 5 that the greatest sum of sensitivity and specificity is for a respiration rate threshold of 5 breaths per minute, for predicting major and moderate adverse clinical events. FIG. 3C shows the ROC curve for a respiration rate threshold of 5 with respect to predicting a likelihood of either a major or a moderate adverse clinical event. The area under the curve is 0.84 with a standard deviation of 0.04, and a p-value of 0.000049.

[0178] Table 6 (shown below) shows the results of the ROC curve analysis of respective respiration rate thresholds (i.e., thresholds for the difference between the maximum respiration rate and that of the previous day), with respect to determining the likelihood of a subject undergoing a major clinical event.

TABLE 6

Respiration rate threshold (breaths per minute)	Sensitivity	Specificity	Sum of Sensitivity and Specificity
0.00	1.00	0.00	1.00
0.50	1.00	0.05	1.05
1.00	1.00	0.06	1.06
1.50	1.00	0.23	1.23
2.00	1.00	0.26	1.26
3.00	1.00	0.42	1.42
3.50	1.00	0.57	1.57
4.00	1.00	0.58	1.58
5.00	1.00	0.69	1.69
6.00	0.73	0.76	1.49
6.50	0.55	0.83	1.37
6.75	0.55	0.84	1.39
7.00	0.55	0.85	1.40
7.50	0.45	0.89	1.35
8.00	0.36	0.89	1.26
9.00	0.27	0.92	1.19
10.00	0.27	0.93	1.20
12.00	0.27	0.93	1.21
16.00	0.27	0.97	1.24
18.00	0.18	0.98	1.16
19.00	0.09	0.98	1.07
24.00	0.00	0.98	0.98
35.00	0.00	0.99	0.99

[0179] It is noted with respect to Table 6 that the greatest sum of sensitivity and specificity is for a respiration rate threshold of 5 breaths per minute for predicting major adverse clinical events. FIG. 3D shows the ROC curve for a respiration rate threshold of 5 with respect to predicting a likelihood of a major adverse clinical event. The area under the curve is 0.85 with a standard deviation of 0.04, and a p-value of 0.00012.

[0180] In general, in accordance with the indications provided by the data in Tables 5 and 6 and in FIGS. 3C and 3D, a subject's respiration rate is monitored. The median (or mean, or maximum) respiration rate over a time duration of more than two hours and less than eight hours (e.g., greater than three hours, greater than four hours, greater than five hours, or greater than six hours) is determined and is compared to the median (or mean, or maximum) respiration rate over a similar time duration at a similar period of the day (e.g., at the same time of day) on at least one previous day (e.g., the previous day). In response to determining (a) that the median (or mean, or maximum) respiration rate of the present day differs from that of the previous day by a threshold amount of more than 3 breaths per minute (e.g., more than 4 breaths per minute), and/or less than 10 breaths per minute (e.g., less than eight, or less than six breaths per minute), then an alert is generated in order to indicate that an adverse clinical event is likely to occur.

[0181] For some applications, the techniques described herein are used in combination with the techniques described

in one or more of the following references, both of which are incorporated herein by reference:

[0182] U.S. Pat. No. 7,077,810 to Lange; and/or

[0183] U.S. Pat. No. 7,314,451 to Halperin.

[0184] For example, for some applications, as is generally described in U.S. Pat. No. 7,077,810 to Lange, pattern analysis module 22 is configured to predict the onset of an asthma attack or a different clinical event, and/or monitor its severity and progression. Module 22 typically analyzes changes in breathing rate and in breathing rate variability patterns in combination to predict the onset of an asthma attack. Although breathing rate typically slightly increases prior to the onset of an attack, this increase alone is not always a specific marker of the onset of an attack. Therefore, in order to more accurately predict the onset of an attack, and monitor the severity and progression of an attack, module 22 typically additionally analyzes changes in breathing rate variability patterns. For some applications, module 22 compares one or more of the following patterns to respective baseline patterns, and interprets a deviation from baseline as indicative of (a) the onset of an attack, and/or (b) the severity of an attack in progress:

[0185] a slow trend breathing rate pattern. Module 22 interprets as indicative of an approaching or progressing attack an increase vs. baseline, for example, for generally healthy subjects, an attenuation of the typical segmented, monotonic decline of breathing rate typically over at least 1 hour, e.g., over at least 2, 3, or 4 hours, or the transformation of this decline into an increasing breathing rate pattern, depending on the severity of the attack;

[0186] a breathing rate variability pattern. Module 22 interprets as indicative of an approaching or progressing attack a decrease in breathing rate variability. Such a decrease generally occurs as the onset of an episode approaches, and intensifies with the progression of shortness of breath during an attack;

[0187] a breathing duty-cycle pattern. Module 22 interprets a substantial increase in the breathing duty-cycle as indicative of an approaching or progressing attack. Breathing duty-cycle patterns include, but are not limited to, inspirium time/total breath cycle time, expirium time/total breath cycle time, and (inspirium+expirium time)/total breath cycle time; and

[0188] interruptions in breathing pattern such as caused by coughs, sleep disturbances, or waking. Module 22 quantifies these events, and determines their relevance to prediction of potential asthma attacks.

[0189] Reference is made to FIG. 4, which is a graph illustrating breathing rate patterns of a chronic asthma patient, and which is the same as FIG. 4 of U.S. Pat. No. 7,077,810 to Lange. Breathing of the asthma patient was monitored during sleep on several nights. The patient's breathing rate was averaged for each hour of sleep (excluding periods of rapid eye movement (REM) sleep). During the first approximately two months that the patient was monitored, the patient did not experience any episodes of asthma. A line 100 is representative of a typical slow trend breathing pattern recorded during this non-episodic period, and thus represents a baseline slow trend breathing rate pattern for this patient. It should be noted that, unlike the monotonic decline in breathing rate typically observed in non-asthmatic patients, the baseline breathing rate pattern of the chronically asthmatic patient of the experiment reflects an initial decline in breathing rate during the first

few hours of sleep, followed by a gradual increase in breathing rate throughout most of the rest of the night.

[0190] Lines 102 and 104 were recorded on two successive nights at the conclusion of the approximately two-month period, line 102 on the first of these two nights, and line 104 on the second of these two nights. The patient experienced an episode of asthma during the second of these nights. Lines 102 and 104 thus represent a pre-episodic slow trend breathing rate pattern and an episodic slow trend breathing rate pattern, respectively. As can be seen in the graph, the patient's breathing rate was substantially elevated vs. baseline during all hours of the pre-episodic night, and even further elevated vs. baseline during the episodic night.

[0191] Using techniques described herein, the pattern of line 102 is compared with the baseline pattern of line 100, in order to predict that the patient may experience an asthmatic episode. The pattern of line 104 is compared with the baseline pattern of line 100 in order to assess a progression of the asthmatic episode.

[0192] In accordance with the data shown in FIG. 4, for some applications, a subject's respiration is detected on first and second days over similar time durations and at similar time periods (e.g., during the first two, three four, five, or six hours of the subject's sleep). A parameter of the subject's respiration based upon the detected respiration rate on the second day is compared with that of the first day. An alert is generated in response to the comparison indicating that an adverse clinical event is approaching, e.g., in response to determining that the difference between the median, the mean, and/or the maximum respiration rate on the second day and that of the first day exceeds a threshold.

[0193] For some applications, techniques as described in U.S. Pat. No. 7,314,451 to Halperin are used in conjunction with the techniques described herein. For example, for some applications, system 10 monitors and records patterns throughout all or a large portion of a night. The resulting data set generally encompasses typical long-term respiratory and heartbeat patterns, and facilitates comprehensive analysis. Additionally, such a large data set enables rejection of segments contaminated with movement or other artifacts, while retaining sufficient data for a statistically significant analysis.

[0194] Although breathing rate typically slightly increases prior to the onset of an asthma attack (or a different adverse clinical event), this increase alone is not always a specific marker of the onset of an attack. Therefore, in order to more accurately predict the onset of an attack, and monitor the severity and progression of an attack, in an embodiment of the present invention, breathing pattern analysis module additionally analyzes changes in breathing rate variability patterns. For some applications, module 22 compares one or more of the following patterns to respective baseline patterns, and interprets a deviation from baseline as indicative of (a) the onset of an attack, and/or (b) the severity of an attack in progress:

[0195] a slow trend breathing rate pattern. Module 22 interprets as indicative of an approaching or progressing attack an increase vs. baseline, for example, for generally healthy subjects, an attenuation of the typical segmented, monotonic decline of breathing rate typically over at least 1 hour, e.g., over at least 2, 3, or 4 hours, or the transformation of this decline into an increasing breathing rate pattern, depending on the severity of the attack;

- [0196]** a breathing rate pattern. Module **22** interprets as indicative of an approaching or progressing attack an increase or lack of decrease in breathing rate during the first several hours of sleep, e.g., during the first 2, 3, or 4 hours of sleep.
- [0197]** a breathing rate variability pattern. Module **22** interprets a decrease in breathing rate variability as indicative of an approaching or progressing attack. Such a decrease generally occurs as the onset of an episode approaches, and intensifies with the progression of shortness of breath during an attack;
- [0198]** a breathing duty-cycle pattern. Module **22** interprets a substantial increase in the breathing duty-cycle as indicative of an approaching or progressing attack. Breathing duty-cycle patterns include, but are not limited to, inspirium time/total breath cycle time, expirium time/total breath cycle time, and (inspirium+expirium time)/total breath cycle time;
- [0199]** a change in breathing rate pattern towards the end of night sleep (typically between about 3:00 A.M. and about 6:00 A.M.); and
- [0200]** interruptions in breathing pattern such as caused by coughs, sleep disturbances, or waking. Module **22** quantifies these events, and determines their relevance to prediction of potential asthma attacks.
- [0201]** Pattern analysis modules **22** and **23** typically determine baseline patterns by analyzing breathing and/or heart rate patterns, respectively, of the subject during non-symptomatic nights. Alternatively or additionally, modules **22** and **23** are programmed with baseline patterns based on population averages. For some applications, such population averages are segmented by characteristic traits such as age, height, weight, and gender.
- [0202]** Reference is again made to FIG. 4, which is a graph illustrating breathing rate patterns of a chronic asthma patient, measured during an experiment conducted in accordance with an embodiment of the present invention. Using techniques described herein, breathing pattern analysis module **22** compares the pattern of line **102** with the baseline pattern of line **100**, in order to predict that the patient may experience an asthmatic episode. Module **22** compares the pattern of line **104** with the baseline pattern of line **100** in order to assess a progression of the asthmatic episode.
- [0203]** For some applications of the present invention, the deviation from baseline is defined as the cumulative deviation of the measured pattern from the baseline pattern. A threshold indicative of a clinical condition is set equal to a certain number of standard errors (e.g., one standard error). Alternatively or additionally, other measures of deviation between measured and baseline patterns are used, such as correlation coefficient, mean square error, maximal difference between the patterns, and the area between the patterns. Further alternatively or additionally, pattern analysis module **16** uses a weighted analysis emphasizing specific regions along the patterns, for example, by giving increased weight (e.g., double weight) to an initial portion of sleep (e.g., the first two hours of sleep) or to specific hours, for example as morning approaches (e.g., the hours of 3:00-6:00 a.m.).
- [0204]** Reference is now made to FIGS. 5 and 6, which are graphs of exemplary baseline and measured breathing rate and heart rate nighttime patterns, respectively, and which are generally similar to FIGS. 6 and 7 of U.S. Pat. No. 7,314,451 to Halperin, which is incorporated herein by reference. Lines **200** and **202** (FIGS. 5 and 6, respectively) represent normal baseline patterns in the absence of an asthma attack. The bars represent one standard error. Lines **204** and **206** (FIGS. 5 and 6, respectively) represent patterns during nights prior to an onset of an asthma attack. Detection of the change in pattern between lines **200** and **202** and lines **204** and **206**, respectively, enables the early prediction of the approaching asthma attack, or other approaching adverse clinical events.
- [0205]** For some applications of the present invention, pattern analysis module **16** is configured to predict the onset of a clinical manifestation of heart failure, and/or monitor its severity and progression. Module **16** typically determines that an episode is imminent when the module detects increased breathing rate accompanied by increased heart rate, and/or when the monitored breathing and/or heartbeat patterns have specific characteristics that relate to heart failure, such as characteristics that are indicative of apnea, Cheyne-Stokes Respiration (CSR), and/or periodic breathing.
- [0206]** In accordance with the data shown in FIG. 5, for some applications, a subject's respiration is detected on first and second days over similar time durations and at similar time periods (e.g., during the first two, three four, five, or six hours of the subject's sleep). A parameter of the subject's respiration based upon the detected respiration rate on the second day is compared with that of the first day. An alert is generated in response to the comparison indicating that an adverse clinical event is approaching, e.g., in response to determining that the difference between the median, the mean, and/or the maximum respiration rate on the second day and that of the first day exceeds a threshold.
- [0207]** In accordance with the data shown in FIG. 6, for some applications, a subject's heart rate is detected on first and second days over similar time durations and at similar time periods (e.g., during the first two, three, four, five, or six hours of the subject's sleep). A parameter of the subject's cardiac cycle based upon the detected heart rate on the second day is compared with that of the first day. An alert is generated in response to the comparison indicating that an adverse clinical event is approaching, e.g., in response to determining that the difference between the median, the mean, and/or the maximum heart rate on the second day and that of the first day exceeds a threshold.
- [0208]** In accordance with the data shown in FIGS. 5 and 6, for some applications, a subject's respiration rate and heart rate are detected on first and second days over similar time durations and at similar time periods (e.g., during the first two, three four, five, or six hours of the subject's sleep). A parameter of the subject's respiration based upon the detected respiration rate on the second day is compared with that of the first day, and a parameter of the subject's cardiac cycle based upon the detected heart rate on the second day is compared with that of the first day. An alert is generated in response to the comparisons indicating that an adverse clinical event is approaching, e.g., in response to determining that (a) the difference between the median, the mean, and/or the maximum respiration rate on the second day and that of the first day exceeds a threshold, and/or (b) the difference between the median, the mean, and/or the maximum heart rate on the second day and that of the first day exceeds a threshold.
- [0209]** Reference is now made to FIG. 7, which is the same as FIG. 23 of U.S. Pat. No. 7,314,451 to Halperin, which is incorporated herein by reference. FIG. 7 is a graph of baseline and breathing rate nighttime patterns, respectively, measured in accordance with some applications of the present invention. A line **400** represents a normal baseline pattern in the

absence of Cheyne-Stokes Respiration, and a line 402 represents a pattern during a night during CSR. The bars represent one standard error. In accordance with the data shown in FIG. 7, for some applications, a subject's respiration is detected on first and second days over similar time durations and at similar time periods (e.g., during the first two, three four, five, or six hours of the subject's sleep). A parameter of the subject's respiration based upon the detected respiration rate on the second day is compared with that of the first day. An alert is generated in response to the comparison indicating that an adverse clinical event is approaching, e.g., in response to determining that the difference between the median, the mean, and/or the maximum respiration rate on the second day and that of the first day exceeds a threshold.

[0210] For some applications, techniques described herein are used in conjunction with techniques as are generally described in US 2007/0118054 to Pinhas, which is incorporated herein by reference. For example, as is described with reference to FIG. 18 of US 2007/0118054 to Pinhas, for some applications, system 10 is adapted to monitor multiple clinical parameters such as respiration rate, heart rate, cough occurrence, body movement, deep inspirations, expiration/inspiration ratio, of subject 12. Pattern analysis module 16 is adapted to analyze the respective patterns in order to identify a change in the baseline pattern of the clinical parameters. In some cases, this change, a new baseline that is significantly different from the previous baseline indicates, for example, a change in medication and provides the caregiver or healthcare professional with feedback on the efficacy of treatment.

[0211] For some applications, system 10 calculates the average respiration rate and heart rate for predefined time segments. Such time segments can be minutes, hours, or days. By analyzing the history of the patient the system can calculate the correlation of respiration rate and heart rate patterns. When an onset of an asthma attack approaches the correlation of heart rate and respiration rate pattern shows a clear change. For each night the respiration rate and heart rate in sleep during the hours of 11:00 pm to 6:00 am (or over a different time period) is averaged. For each date, a respiration vector of length N with the average respiration rate of the last N nights and a heart rate vector of length N with the average heart rate for the last N nights is defined. N is typically between 3 and 30, for example 10. The correlation coefficient of the heart rate vector and the respiration vector is calculated for each date by system 10. A moving window of several days is used to calculate correlation coefficient changes between the respiration and heart rate vectors. A steady correlation coefficient pattern over at least several days is required to identify a significant change of correlation coefficient from one time interval to another. A significant change is defined as a change in the correlation coefficient level of a magnitude larger than the typical correlation coefficient variation in the previous time interval, e.g., a change larger than 3 standard deviations of the correlation coefficient signal in the previous time interval. System 10 identifies such a significant change as an indication of an approaching clinical event.

[0212] As described in US 2007/0118054 to Pinhas, for some applications, during sleep, sleep stage is identified using techniques described therein. For each identified sleep stage, the average respiration rate, heart rate and other clinical parameters are calculated. This data is compared to baseline defined for that subject for each identified sleep stage, in order to identify the onset or progress of a clinical episode.

[0213] For some applications, for each night, for each hour (or for longer durations of time, such as more than two hours, as described hereinabove) of sleep, counted from the onset of sleep, the average respiration rate, heart rate and other clinical parameters are calculated. This data is compared to baseline in order to identify the onset or progress of a clinical episode.

[0214] For some applications, for each night, for each hour (or for longer durations of time, such as more than two hours, as described hereinabove), the average respiration rate, heart rate and other clinical parameters are calculated. This data is compared to baseline in order to identify the onset or progress of a clinical episode. For example, the average respiration rate in sleep during 2:00 AM-3:00 AM is calculated and compared to baseline for that subject in order to identify the onset or progress of a clinical episode.

[0215] In an embodiment of the present invention, system 10 is configured to identify early signs of an onset of hypoglycemia in a diabetic subject. The system identifies an increase in a level of physiological tremor as being indicative of such onset, and/or an increase in the level of tremor in combination with other parameters described hereinabove, such as heart rate, respiration rate, and/or awakenings, and/or a change in the heart beat pattern indicative of palpitations (by analyzing the timing between peaks of the heart beat signal, using techniques described herein). Typically, the system detects physiologic tremor by monitoring body motion at between about 4 Hz and about 18 Hz, such as between about 8 Hz and about 12 Hz. Alternatively, the system identifies the increase in the level of physiological tremor as being indicative of an onset or progression of a condition selected from the list consisting of: Parkinson's disease, Alzheimer's disease, stroke, essential tremor, epilepsy, stress, fibrillation, and anaphylactic shock. For some applications, system 10 is adapted to drive user interface 24 to display one or more properties of the detected physiological tremor, such as an amplitude or spectrum image of the tremor. For example, system 10 may be used as a bedside hospital vital signs diagnostic system. For some applications, the hypoglycemia is identified by analyzing the heart signal to identify palpitations. Palpitations are identified as an increase in the heart rate and/or an increase in the irregularity of the heart beat (patients often characterize palpitations as "missing heart beats").

[0216] There are multiple clinical uses for the measurement of tremor. One application is the monitoring of diabetic patients to identify hypoglycemia. Typically, tremor-related oscillations exist in a frequency band of 3-18 Hz. In one embodiment, motion data acquisition module 20 and pattern analysis module 16 are adapted to digitize and analyze data at those frequencies. A significant change in the energy measured in this frequency range is attributed to a change in the level of tremor, and the change in the spectrum of the signal is attributed to a change in the spectrum of the tremor.

[0217] FIG. 8 shows an example of data acquired and analyzed by one embodiment of the present invention in monitoring a human subject with voluntarily induced increased tremor. The top graph shows the sampled data filtered with a band pass filter at 2-10 Hz (line 161) as a function of time. The dashed line 162 indicates the timing where the voluntarily induced increased tremor began. Area 163 (on the right side of line 162) shows the effect of the increased tremor, which caused an increase in signal amplitude. The bottom graph shows the corresponding time dependent total spectrum power at the frequency band of 3-9 Hz (line 164). Line 165 indicates the timing where the stimulated increased tremor

began. Area 166 (on the right side of line 165) shows the increased tremor energy measured by that embodiment.

[0218] In one embodiment, system 10 first identifies the signal associated with heart rate and respiration rate. The system subtracts the heart rate and respiration rate signal from the overall signal. The resulting signal in those areas where there are no restlessness events is regarded as the tremor signal for the above analysis. In one embodiment, the energy of the tremor signal is normalized by the size of the respiration and/or heart signal.

[0219] In children, hypoglycemia during night sleep is a major concern. A night-time “hypoglycemia alarm” is provided to prevent this deterioration, in accordance with some embodiments of the invention. Direct continuous measurement of blood glucose level during sleep is of limited practicality with standard commercial glucose sensing products, and thus a non-invasive method for generating a hypoglycemia alarm is beneficial. Since hypoglycemia imposes an extreme metabolic deficiency, autonomic nervous system effects such as changes in heart and respiration rates, restlessness in sleep and tremor are often evident.

[0220] In one embodiment, system 10 tracks one or more critical parameters. “Critical parameters,” in the context of the present patent application and in the claims, refers to respiration rate, heart rate, occurrence of palpitations, restlessness in sleep and tremor. Changes in the critical parameters associated with developing hypoglycemia during night sleep are tracked using system 10 for the purpose of providing a real-time alarm in case of an oncoming hypoglycemia episode. For example, in one embodiment, at the beginning of the night sleep, system 10 calculates the baseline reference level of one or more of the critical parameters. Then every time interval, for example, one minute, system 10 calculates the same parameters and compares them to the baseline data. A significant increase of, for example, over 25% is used as an indication of an oncoming hypoglycemia event and an alarm is activated. In one embodiment, a combined score of the critical parameters is calculated. For example, a hypoglycemia score (HypSc) may be calculated by:

$$\text{HypSc}=(\text{RRS}+\text{HRS}+\text{TRS}+\text{RSS})/4 \quad (\text{Equation 4})$$

Where:

$$\text{RRS}=(\text{current respiration rate})/(\text{baseline respiration rate}) * 100$$

$$\text{HRS}=(\text{current heart rate})/(\text{baseline heart rate}) * 100$$

$$\text{TRS}=(\text{current tremor level})/(\text{baseline tremor level}) * 100$$

$$\text{RSS}=(\text{current restlessness level})/(\text{baseline respiration level}) * 100.$$

[0221] Then the score is compared to a learned or pre-defined threshold, for example 125. If the score exceeds the threshold, an event warning is given. In one embodiment, the baseline values are the reference values at the beginning of the night sleep. In another embodiment, the baseline values are the average values measured for that subject at that same time of night during K previous asymptomatic nights, where $1 < K < 100$, typically $K=10$. In another embodiment, the baseline values are population averages known for the subject's age, size, and gender.

[0222] Reference is again made to FIG. 2. For some applications, drug treatment information is directly transmitted to

system 10 from a drug administration device 266, rather than manually entered into user interface 24. Such drug information treatment may include, for example, which drug has been administered (and/or the drug's active ingredients), the dosage of the administered drug, and/or the timing of the administration. For some applications, system 10 takes the drug treatment information into account when determining the dosage and/or drug administration timing information that the system provides to drug administration device 266. Transmission of data to system 10 may be performed wirelessly or via wires. For example, drug administration device 266 may comprise a commercially-available drug administration device having communication capability, such as the Nebulizer Chronolog (Medtrac Technologies, Inc., Lakewood, Colo., USA), or the Doser (MEDITRACK Products, Hudson, Mass.).

[0223] In one embodiment, system 10 includes drug administration device 266 that delivers glucose to the patient upon detection of a hypoglycemia event. Glucose is delivered either orally or into the subject's body. In one embodiment, a drug administration device 266 dispenses a glucose spray in the vicinity of the patient's mouth to be inhaled without necessarily waking the subject and without necessarily contacting the subject's body.

[0224] It will be appreciated by persons skilled in the art that the present invention is not limited to what has been particularly shown and described hereinabove. Rather, the scope of the present invention includes both combinations and subcombinations of the various features described hereinabove, as well as variations and modifications thereof that are not in the prior art, which would occur to persons skilled in the art upon reading the foregoing description.

1-38. (canceled)

39. A method for detecting an onset of a hypoglycemia episode in a subject, the method comprising:

- monitoring one or more critical parameters for hypoglycemia without contacting the subject;
- detecting a variation of at least one of the critical parameters; and
- activating an alarm when at least one of the critical parameters deviates from an accepted value.

40. The method as recited in claim 39, wherein the method further comprises determining a baseline level of at least one of the critical parameters, and wherein detecting the variation comprises detecting the variation of said at least one of the critical parameters from said baseline level.

41. The method as recited in claim 39, wherein the method is practiced while the subject is asleep.

42. The method as recited in claim 39, wherein the method is practiced without requiring compliance of the subject.

43. Apparatus for detecting an onset of a hypoglycemia episode in a subject, the apparatus comprising:

- at least one sensor configured to monitor one or more critical parameters for hypoglycemia without contacting or viewing the subject, and to generate a signal in response thereto; and

a control unit configured to:

- by analyzing the signal, detect the onset of the hypoglycemia episode by detecting a variation of at least one of the critical parameters from a baseline level, and
- activate an alarm in response thereto.

- 44.** The apparatus as recited in claim **43**, wherein the control unit is further configured to determine the baseline level of the at least one of the critical parameters.
- 45.** The apparatus as recited in claim **43**, wherein the critical parameters include at least one parameter selected from the group consisting of: respiration rate, heart rate, occurrence of palpitations, restlessness, and tremor, the control unit being configured to detect a variation of the at least one selected parameter.
- 46.** The apparatus as recited in claim **43**, wherein the apparatus is configured to be used while the subject is asleep.
- 47.** The apparatus according to claim **43**, wherein the apparatus is configured to be used without requiring compliance of the subject.
- 48.** The apparatus according to claim **45**, wherein the critical parameters include tremor, the control unit being configured to detect the variation of the tremor.
- 49.** The apparatus according to claim **48**, wherein the control unit is configured to detect the variation of the tremor by monitoring body motion of the subject at between 3 and 18 Hz.
- 50.** The apparatus according to claim **49**, wherein the control unit is configured to detect the variation of the tremor by monitoring body motion of the subject at between 8 and 12 Hz.
- 51.** The apparatus according to claim **48**, wherein the control unit is configured to:
- identify a tremor signal by subtracting a heart rate signal and a respiration rate signal from the generated signal, and
 - detect the variation of the tremor by analyzing the tremor signal.
- 52.** The apparatus according to claim **43**, wherein the control unit is configured to detect the variation by:
- calculating a hypoglycemia score that is an average of (a) a ratio of a current respiration rate to a baseline respiration rate, (b) a ratio of a current heart rate to a baseline heart rate, (c) a ratio of a current tremor level to a baseline tremor level, and (d) a ratio of a current restlessness level to a baseline restlessness level, and
 - comparing the hypoglycemia score to a threshold.
- 53.** The apparatus according to claim **43**, further comprising a drug administration device, wherein the control unit is configured to drive the drug administration device to deliver glucose to the subject upon detecting the onset of the hypoglycemia episode.
- 54.** The apparatus according to claim **53**, wherein the drug administration device comprises a spray dispenser.

* * * * *

专利名称(译)	监测受试者的状况		
公开(公告)号	US20140350360A1	公开(公告)日	2014-11-27
申请号	US14/454300	申请日	2014-08-07
[标]申请(专利权)人(译)	EARLYSENSE		
申请(专利权)人(译)	EARLYSENSE LTD.		
当前申请(专利权)人(译)	EARLYSENSE LTD.		
[标]发明人	HALPERIN AVNER AVERBOUKH ARKADI		
发明人	HALPERIN, AVNER AVERBOUKH, ARKADI		
IPC分类号	A61B5/145 A61B5/0205 A61B5/11 A61B5/00		
CPC分类号	A61B5/14532 A61B5/746 A61B5/7282 A61B5/0205 A61B5/7278 A61B5/02405 A61B5/11 A61B5/4839 A61B5/6892 A61B5/0816 A61B5/4806 A61B5/4356 A61B5/02 A61B5/024 A61B5/08 A61B5/0823 A61B5/1107 A61B5/113 A61B5/4343 A61B5/4818 A61B5/4836 A61B5/7246 A61B5/7275 G16H40/60 G16H50/30		
优先权	60/731934 2005-11-01 US 60/784799 2006-03-23 US 60/843672 2006-09-12 US		
其他公开文献	US8942779		
外部链接	Espacenet USPTO		

摘要(译)

描述了装置和方法，包括用于检测受试者中低血糖发作的发作的方法。监测低血糖的一个或多个关键参数而不接触受试者。检测至少一个关键参数的变化，并且当至少一个关键参数偏离可接受值时激活警报。还描述了其他应用。

