



US009974457B2

(12) **United States Patent**
Ghosh et al.

(10) **Patent No.:** **US 9,974,457 B2**
(45) **Date of Patent:** **May 22, 2018**

(54) **ASSESSING INTRA-CARDIAC ACTIVATION PATTERNS**

- (71) Applicant: **Medtronic, Inc.**, Minneapolis, MN (US)
- (72) Inventors: **Subham Ghosh**, Circle Pines, MN (US); **Jeffrey M. Gillberg**, Coon Rapids, MN (US); **Robert W. Stadler**, Shoreview, MN (US)
- (73) Assignee: **Medtronic, Inc.**, Minneapolis, MN (US)

(*) Notice: Subject to any disclaimer, the term of this patent is extended or adjusted under 35 U.S.C. 154(b) by 353 days.

(21) Appl. No.: **14/635,498**

(22) Filed: **Mar. 2, 2015**

(65) **Prior Publication Data**
US 2015/0216434 A1 Aug. 6, 2015

Related U.S. Application Data
(63) Continuation of application No. 13/462,480, filed on May 2, 2012, now Pat. No. 8,972,228.
(Continued)

(51) **Int. Cl.**
G06G 7/48 (2006.01)
A61B 5/04 (2006.01)
(Continued)

(52) **U.S. Cl.**
CPC **A61B 5/04012** (2013.01); **A61B 5/02** (2013.01); **A61B 5/0402** (2013.01); **A61B 5/044** (2013.01);
(Continued)

(58) **Field of Classification Search**
CPC A61B 5/042; A61B 5/686; A61B 6/503; A61B 5/029; A61N 1/368; A61N 1/3686; G06T 7/0012

See application file for complete search history.

(56) **References Cited**

U.S. PATENT DOCUMENTS

- 4,233,987 A 11/1980 Feingold
- 4,402,323 A 9/1983 White
- (Continued)

FOREIGN PATENT DOCUMENTS

- CN 1043621 A 7/1990
- CN 1253761 5/2000
- (Continued)

OTHER PUBLICATIONS

Miri et al., "Comparison of the electrophysiologically based optimization methods with different pacing parameters in patient undergoing resynchronization treatment", 30th Annual International IEEE EMBS Conference, Aug. 2008.*

(Continued)

Primary Examiner — Kandasamy Thangavelu
(74) *Attorney, Agent, or Firm* — Shumaker & Sieffert, P.A.

(57) **ABSTRACT**

Techniques for evaluating cardiac electrical dyssynchrony are described. In some examples, an activation time is determined for each of a plurality of torso-surface potential signals. The dispersion or sequence of these activation times may be analyzed or presented to provide variety of indications of the electrical dyssynchrony of the heart of the patient. In some examples, the locations of the electrodes of the set of electrodes, and thus the locations at which the torso-surface potential signals were sensed, may be projected on the surface of a model torso that includes a model heart. The inverse problem of electrocardiography may be solved to determine electrical activation times for regions of the model heart based on the torso-surface potential signals sensed from the patient.

24 Claims, 12 Drawing Sheets

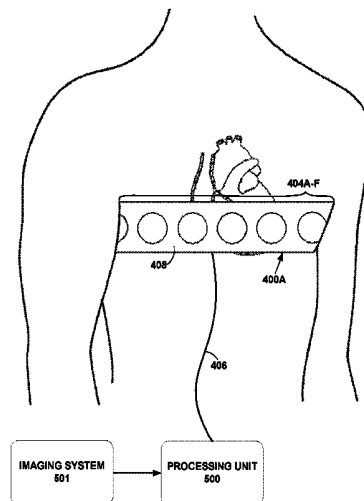

Related U.S. Application Data					
(60)	Provisional application No. 61/482,053, filed on May 3, 2011.			6,480,745 B2	11/2002 Nelson et al.
(51)	Int. Cl.			6,484,118 B1	11/2002 Govari
	<i>A61B 5/0452</i> (2006.01)			6,507,756 B1	1/2003 Heynen et al.
	<i>A61B 5/05</i> (2006.01)			6,532,379 B2	3/2003 Stratbucker
	<i>A61B 5/02</i> (2006.01)			6,584,343 B1	6/2003 Ransbury et al.
	<i>A61B 5/0402</i> (2006.01)			6,599,250 B2	7/2003 Webb et al.
	<i>A61B 5/0408</i> (2006.01)			6,625,482 B1	9/2003 Panescu et al.
	<i>A61N 1/04</i> (2006.01)			6,640,136 B1	10/2003 Helland et al.
	<i>A61N 1/362</i> (2006.01)			6,650,927 B1	11/2003 Keidar
	<i>A61N 1/368</i> (2006.01)			6,766,189 B2	7/2004 Yu et al.
	<i>A61B 5/00</i> (2006.01)			6,772,004 B2	8/2004 Rudy
	<i>A61B 5/044</i> (2006.01)			6,804,555 B2	10/2004 Warkentin
(52)	U.S. Cl.			6,847,836 B1	1/2005 Sujdak
	CPC <i>A61B 5/0452</i> (2013.01); <i>A61B 5/04085</i> (2013.01); <i>A61B 5/05</i> (2013.01); <i>A61B 5/742</i> (2013.01); <i>A61N 1/0476</i> (2013.01); <i>A61N 1/0484</i> (2013.01); <i>A61N 1/3627</i> (2013.01); <i>A61N 1/3682</i> (2013.01); <i>A61N 1/3684</i> (2013.01)			6,856,830 B2	2/2005 He
				6,882,882 B2	4/2005 Struble et al.
				6,885,889 B2	4/2005 Chinchoy
				6,915,149 B2	7/2005 Ben-Haim
				6,968,237 B2	11/2005 Doan et al.
				6,975,900 B2	12/2005 Rudy et al.
				6,978,184 B1	12/2005 Marcus et al.
				6,980,675 B2	12/2005 Evron et al.
				7,016,719 B2	3/2006 Rudy et al.
				7,031,777 B2	4/2006 Hine et al.
				7,058,443 B2	6/2006 Struble
				7,062,315 B2	6/2006 Koyrakh et al.
				7,092,759 B2	8/2006 Nehls et al.
				7,142,922 B2	11/2006 Spinelli et al.
				7,184,835 B2	2/2007 Kramer et al.
				7,215,998 B2	5/2007 Wesselink et al.
				7,286,866 B2	10/2007 Okerlund et al.
				7,308,297 B2	12/2007 Reddy et al.
				7,308,299 B2	12/2007 Burrell et al.
				7,313,444 B2	12/2007 Pianca et al.
				7,321,677 B2	1/2008 Evron et al.
				7,346,381 B2	3/2008 Okerlund et al.
				7,398,116 B2	7/2008 Edwards
				7,426,412 B1	9/2008 Schecter
				7,454,248 B2	11/2008 Burrell et al.
				7,499,743 B2	3/2009 Vass et al.
				7,509,170 B2	3/2009 Zhang et al.
				7,565,190 B2	7/2009 Okerlund et al.
				7,587,074 B2	9/2009 Zarkh et al.
				7,599,730 B2	10/2009 Hunter et al.
				7,610,088 B2	10/2009 Chinchoy
				7,613,500 B2	11/2009 Vass et al.
				7,616,993 B2	11/2009 Müssig et al.
				7,664,550 B2	2/2010 Eick et al.
				7,684,863 B2	3/2010 Parikh et al.
				7,742,629 B2	6/2010 Zarkh et al.
				7,747,047 B2	6/2010 Okerlund et al.
				7,751,882 B1	7/2010 Helland et al.
				7,769,451 B2	8/2010 Yang et al.
				7,778,685 B2	8/2010 Evron et al.
				7,778,686 B2	8/2010 Vass et al.
				7,787,951 B1	8/2010 Min
				7,813,785 B2	10/2010 Okerlund et al.
				7,818,040 B2	10/2010 Spear et al.
				7,848,807 B2	12/2010 Wang
				7,860,580 B2	12/2010 Falk et al.
				7,894,889 B2	2/2011 Zhang
				7,912,544 B1	3/2011 Min et al.
				7,917,214 B1	3/2011 Gill et al.
				7,941,213 B2	5/2011 Markowitz et al.
				7,953,475 B2	5/2011 Harley et al.
				7,953,482 B2	5/2011 Hess
				7,983,743 B2	7/2011 Rudy et al.
				7,996,063 B2	8/2011 Vass et al.
				7,996,070 B2	8/2011 van Dam et al.
				8,010,194 B2	8/2011 Muller
				8,019,402 B1	9/2011 Kryzpow et al.
				8,019,409 B2	9/2011 Rosenberg et al.
				8,032,229 B2	10/2011 Gerber et al.
				8,036,743 B2	10/2011 Savage et al.
				8,060,185 B2	11/2011 Hunter et al.
				8,150,513 B2	4/2012 Chinchoy
				8,160,700 B1	4/2012 Ryu et al.
				8,175,703 B2	5/2012 Dong et al.
				8,180,428 B2	5/2012 Kaiser et al.
				8,195,292 B2	6/2012 Rosenberg et al.
(56)	References Cited				
	U.S. PATENT DOCUMENTS				
	4,428,378 A	1/1984	Anderson et al.		
	4,497,326 A	2/1985	Curry		
	4,566,456 A	1/1986	Koning et al.		
	4,593,702 A	6/1986	Kepski		
	4,674,511 A	6/1987	Cartmell		
	4,763,660 A	8/1988	Kroll et al.		
	4,777,955 A	10/1988	Brayten et al.		
	4,787,389 A	11/1988	Tarjan		
	4,979,507 A	12/1990	Heinz et al.		
	5,052,388 A	10/1991	Sivula et al.		
	5,054,496 A	10/1991	Wen et al.		
	5,311,873 A	5/1994	Savard et al.		
	5,331,960 A	7/1994	Lavine		
	5,334,220 A	8/1994	Gold et al.		
	5,443,492 A	8/1995	Stokes et al.		
	5,485,849 A	1/1996	Panescu et al.		
	5,514,163 A	5/1996	Markowitz et al.		
	5,552,645 A	9/1996	Weng		
	5,628,778 A	5/1997	Kruse et al.		
	5,671,752 A	9/1997	Sinderby et al.		
	5,683,429 A	11/1997	Mehra		
	5,683,432 A	11/1997	Goedeke et al.		
	5,687,737 A	11/1997	Branham et al.		
	5,810,740 A	9/1998	Paisner		
	5,876,336 A	3/1999	Swanson et al.		
	5,891,045 A	4/1999	Albrecht et al.		
	5,922,014 A	7/1999	Warman et al.		
	6,055,448 A	4/2000	Anderson et al.		
	6,128,535 A	10/2000	Maarse et al.		
	6,141,588 A	10/2000	Cox et al.		
	6,187,032 B1	2/2001	Ohyu et al.		
	6,205,357 B1	3/2001	Ideker et al.		
	6,226,542 B1	5/2001	Reisfeld		
	6,236,883 B1	5/2001	Ciaccio et al.		
	6,243,603 B1	6/2001	Ideker et al.		
	6,246,898 B1	6/2001	Vesely et al.		
	6,301,496 B1	10/2001	Reisfeld		
	6,311,089 B1	10/2001	Mann et al.		
	6,330,476 B1	12/2001	Ben-Ham et al.		
	6,358,214 B1	3/2002	Tereschouk		
	6,377,856 B1	4/2002	Carson		
	6,381,493 B1	4/2002	Stadler et al.		
	6,393,316 B1	5/2002	Gillberg et al.		
	6,418,346 B1	7/2002	Nelson et al.		
	6,442,433 B1	8/2002	Linberg		
	6,456,867 B2	9/2002	Reisfeld		
	6,473,638 B2	10/2002	Ferek-Petric		

(56)		References Cited			
		U.S. PATENT DOCUMENTS			
8,213,693	B1	7/2012	Li	2006/0074285	A1 4/2006 Zarkh et al.
8,214,041	B2	7/2012	Van Gelder et al.	2006/0224198	A1 10/2006 Dong et al.
8,265,736	B2*	9/2012	Sathaye A61N 1/3686	2006/0235478	A1 10/2006 Van Gelder et al.
			600/509	2006/0253162	A1 11/2006 Zhang et al.
				2007/0142871	A1 6/2007 Libbus et al.
				2007/0232943	A1* 10/2007 Harel G06T 7/0012
					600/508
8,265,738	B1	9/2012	Min et al.	2007/0250129	A1 10/2007 Van Oort
8,285,377	B2	10/2012	Rosenberg et al.	2007/0265508	A1 11/2007 Sheikhzadeh-Nadjar et al.
8,295,943	B2	10/2012	Eggen et al.	2008/0021336	A1 1/2008 Dobak et al.
8,326,419	B2	12/2012	Rosenberg et al.	2008/0058656	A1 3/2008 Costello et al.
8,332,030	B2	12/2012	Hess et al.	2008/0119903	A1 5/2008 Arcot-Krishnamurthy et al.
8,380,308	B2	2/2013	Rosenberg et al.	2008/0140143	A1 6/2008 Ettori et al.
8,401,616	B2	3/2013	Verard et al.	2008/0146954	A1 6/2008 Bojovic et al.
8,478,388	B2	7/2013	Nguyen et al.	2008/0242976	A1 10/2008 Robertson et al.
8,509,896	B2	8/2013	Doerr et al.	2008/0269818	A1 10/2008 Sullivan et al.
8,527,051	B1	9/2013	Hedberg et al.	2008/0269823	A1 10/2008 Burnes et al.
8,583,230	B2	11/2013	Ryu et al.	2008/0281195	A1 11/2008 Heimdal
8,615,298	B2	12/2013	Ghosh et al.	2008/0306567	A1 12/2008 Park et al.
8,617,082	B2	12/2013	Zhang et al.	2008/0306568	A1 12/2008 Ding et al.
8,620,433	B2	12/2013	Ghosh et al.	2009/0005832	A1 1/2009 Zhu et al.
8,639,333	B2	1/2014	Stadler et al.	2009/0036947	A1 2/2009 Westlund et al.
8,694,099	B2	4/2014	Ghosh et al.	2009/0043352	A1 2/2009 Brooke et al.
8,738,132	B1	5/2014	Ghosh et al.	2009/0048528	A1 2/2009 Hopenfeld et al.
8,744,576	B2	6/2014	Munsterman et al.	2009/0053102	A2 2/2009 Rudy et al.
8,768,465	B2	7/2014	Ghosh et al.	2009/0054941	A1 2/2009 Eggen et al.
8,805,504	B2	8/2014	Sweeney	2009/0054946	A1 2/2009 Sommer et al.
8,929,984	B2	1/2015	Ghosh et al.	2009/0084382	A1 4/2009 Jalde et al.
8,972,228	B2	3/2015	Ghosh et al.	2009/0093857	A1 4/2009 Markowitz et al.
9,002,454	B2	4/2015	Ghosh et al.	2009/0099468	A1 4/2009 Thiagalingam et al.
9,037,238	B2	5/2015	Stadler et al.	2009/0099469	A1 4/2009 Flores
9,155,897	B2	10/2015	Ghosh et al.	2009/0099619	A1 4/2009 Lessmeier et al.
9,199,087	B2	12/2015	Stadler et al.	2009/0112109	A1 4/2009 Kuklik et al.
9,265,951	B2	2/2016	Sweeney	2009/0143838	A1 6/2009 Libbus et al.
9,265,954	B2	2/2016	Ghosh	2009/0157134	A1 6/2009 Ziglio et al.
9,265,955	B2	2/2016	Ghosh	2009/0157136	A1 6/2009 Yang et al.
9,272,148	B2	3/2016	Ghosh	2009/0198298	A1 8/2009 Kaiser et al.
9,278,219	B2	3/2016	Ghosh	2009/0216112	A1 8/2009 Assis et al.
9,278,220	B2	3/2016	Ghosh	2009/0232448	A1 9/2009 Barmash et al.
9,282,907	B2	3/2016	Ghosh	2009/0234414	A1 9/2009 Sambelashvili et al.
9,320,446	B2	4/2016	Gillberg et al.	2009/0254140	A1 10/2009 Rosenberg et al.
9,381,362	B2	7/2016	Ghosh et al.	2009/0270729	A1 10/2009 Corbucci et al.
9,474,457	B2	10/2016	Ghosh et al.	2009/0270937	A1 10/2009 Yonce et al.
9,486,151	B2	11/2016	Ghosh et al.	2009/0299201	A1 12/2009 Gunderson
9,586,050	B2	3/2017	Ghosh et al.	2009/0299423	A1 12/2009 Min
9,586,052	B2	3/2017	Gillberg et al.	2009/0306732	A1 12/2009 Rosenberg et al.
9,591,982	B2	3/2017	Ghosh et al.	2009/0318995	A1 12/2009 Keel et al.
9,700,728	B2	7/2017	Ghosh	2010/0022873	A1 1/2010 Hunter et al.
9,757,567	B2	9/2017	Ghosh et al.	2010/0049063	A1 2/2010 Dobak, III
9,764,143	B2	9/2017	Ghosh et al.	2010/0069987	A1 3/2010 Min et al.
9,776,009	B2	10/2017	Ghosh et al.	2010/0087888	A1 4/2010 Maskara
2002/0072682	A1	6/2002	Hopman et al.	2010/0094149	A1 4/2010 Kohut et al.
2002/0087089	A1	7/2002	Ben-Haim	2010/0113954	A1 5/2010 Zhou
2002/0143264	A1	10/2002	Ding et al.	2010/0114229	A1 5/2010 Chinchoy
2002/0161307	A1	10/2002	Yu et al.	2010/0121403	A1 5/2010 Schechter et al.
2002/0169484	A1	11/2002	Mathis et al.	2010/0145405	A1 6/2010 Min et al.
2003/0018277	A1	1/2003	He	2010/0174137	A1 7/2010 Shim
2003/0050670	A1	3/2003	Spinelli et al.	2010/0198292	A1 8/2010 Honeck et al.
2003/0105495	A1	6/2003	Yu et al.	2010/0228138	A1 9/2010 Chen
2003/0236466	A1	12/2003	Tarjan et al.	2010/0234916	A1* 9/2010 Turcott A61N 1/368
2004/0015081	A1	1/2004	Kramer et al.		607/30
2004/0059237	A1	3/2004	Narayan et al.	2010/0249622	A1 9/2010 Olson
2004/0097806	A1	5/2004	Hunter et al.	2010/0254583	A1* 10/2010 Chan A61B 6/503
2004/0102812	A1	5/2004	Yonce et al.		382/131
2004/0122479	A1	6/2004	Spinelli et al.	2010/0268059	A1 10/2010 Ryu et al.
2004/0162496	A1	8/2004	Yu et al.	2011/0004111	A1 1/2011 Gill et al.
2004/0172078	A1	9/2004	Chinchoy	2011/0004264	A1 1/2011 Siejko et al.
2004/0172079	A1	9/2004	Chinchoy	2011/0022112	A1 1/2011 Min
2004/0193223	A1	9/2004	Kramer et al.	2011/0054286	A1 3/2011 Crosby
2004/0215245	A1	10/2004	Stahmann et al.	2011/0054559	A1 3/2011 Rosenberg et al.
2004/0215252	A1	10/2004	Verbeek et al.	2011/0054560	A1 3/2011 Rosenberg et al.
2004/0220635	A1	11/2004	Burnes	2011/0075896	A1 3/2011 Matsumoto
2004/0267321	A1	12/2004	Boileau et al.	2011/0092809	A1* 4/2011 Nguyen A61B 5/042
2005/0008210	A1	1/2005	Evron et al.		600/424
2005/0027320	A1	2/2005	Nehls et al.	2011/0112398	A1 5/2011 Zarkh et al.
2005/0090870	A1	4/2005	Hine et al.	2011/0118803	A1 5/2011 Hou et al.
2005/0096522	A1	5/2005	Reddy et al.	2011/0137369	A1 6/2011 Ryu et al.
2005/0149138	A1	7/2005	Min et al.	2011/0144510	A1* 6/2011 Ryu A61B 5/042
					600/509

(56)

References Cited

FOREIGN PATENT DOCUMENTS

U.S. PATENT DOCUMENTS			FOREIGN PATENT DOCUMENTS		
			CN	1878595	12/2006
			CN	101073502	11/2007
2011/0172728	A1	7/2011 Wang	EP	1 072 284 A2	1/2001
2011/0190615	A1	8/2011 Phillips et al.	EP	1072284 A2	1/2001
2011/0201915	A1	8/2011 Gogin et al.	EP	1 504 713 A1	2/2005
2011/0213260	A1	9/2011 Keel et al.	EP	1504713 A1	2/2005
2011/0319954	A1*	12/2011 Niazi A61B 5/686	EP	2 016 976 A1	1/2009
		607/17	EP	2016976 A1	1/2009
2012/0004567	A1	1/2012 Eberle et al.	EP	2391270 A1	12/2011
2012/0101543	A1	4/2012 Demmer et al.	EP	1 925 337 B1	3/2012
2012/0101546	A1	4/2012 Stadler et al.	EP	1925337 B1	3/2012
2012/0109244	A1	5/2012 Anderson et al.	EP	2 436 309 A2	4/2012
2012/0203090	A1*	8/2012 Min A61B 5/029	EP	2436309 A2	4/2012
		600/374	EP	2 435 132 B1	8/2013
2012/0253419	A1	10/2012 Rosenberg et al.	EP	2435132 B1	8/2013
2012/0283587	A1	11/2012 Ghosh et al.	WO	WO 1998/026712 A1	6/1998
2012/0284003	A1	11/2012 Ghosh et al.	WO	WO 1999006112 A1	2/1999
2012/0296387	A1	11/2012 Zhang et al.	WO	WO 2000/045700 A1	8/2000
2012/0296388	A1	11/2012 Zhang et al.	WO	WO 2001/067950 A1	9/2001
2012/0302904	A1	11/2012 Lian et al.	WO	WO 03070323 A1	8/2003
2012/0303084	A1	11/2012 Kleckner et al.	WO	WO 2005/056108 A2	6/2005
2012/0310297	A1	12/2012 Sweeney	WO	WO 2006069215 A2	6/2006
2012/0330179	A1	12/2012 Yuk et al.	WO	WO 2006/105474 A2	10/2006
2013/0006332	A1	1/2013 Sommer et al.	WO	WO 2006/115777 A1	11/2006
2013/0018250	A1	1/2013 Caprio et al.	WO	WO 2006/117773 A1	11/2006
2013/0018251	A1	1/2013 Caprio et al.	WO	WO 2007/013994 A2	2/2007
2013/0030491	A1	1/2013 Stadler et al.	WO	WO 2007027940 A2	3/2007
2013/0060298	A1	3/2013 Splett et al.	WO	WO 2007/013994 A3	4/2007
2013/0072790	A1	3/2013 Ludwig et al.	WO	WO 2007/139456 A1	12/2007
2013/0096446	A1	4/2013 Michael et al.	WO	WO 2008/151077 A2	12/2008
2013/0116739	A1	5/2013 Brada et al.	WO	WO 2009/079344 A1	6/2009
2013/0131529	A1	5/2013 Jia et al.	WO	WO 2009/139911 A2	11/2009
2013/0131749	A1	5/2013 Sheldon et al.	WO	WO 2009/148429 A1	12/2009
2013/0131751	A1	5/2013 Stadler et al.	WO	WO 2010/019494 A1	2/2010
2013/0136035	A1	5/2013 Bange et al.	WO	2010071520 A1	6/2010
2013/0165983	A1	6/2013 Ghosh et al.	WO	WO 2010/071520 A1	6/2010
2013/0165988	A1	6/2013 Ghosh	WO	WO 2010/088040 A1	8/2010
2013/0261471	A1	10/2013 Saha et al.	WO	WO 2010/088485 A1	8/2010
2013/0261688	A1	10/2013 Dong et al.	WO	WO 2011/070166 A1	6/2011
2013/0289640	A1	10/2013 Zhang et al.	WO	WO 2011/090622 A1	7/2011
2013/0296726	A1	11/2013 Niebauer et al.	WO	WO 2011/099992 A1	8/2011
2013/0304407	A1	11/2013 George et al.	WO	WO 2012/037471 A2	3/2012
2013/0324828	A1	12/2013 Nishiwaki et al.	WO	WO 2012/037471 A3	6/2012
2014/0005563	A1	1/2014 Ramanathan et al.	WO	WO 2012/106297 A2	8/2012
2014/0018872	A1	1/2014 Siejko et al.	WO	WO 2012/106297 A3	8/2012
2014/0135866	A1	5/2014 Ramanathan et al.	WO	WO 2012/109618 A2	8/2012
2014/0135867	A1	5/2014 Demmer et al.	WO	WO 2012/110940 A1	8/2012
2014/0163633	A1	6/2014 Ghosh et al.	WO	WO 2012/109618 A3	11/2012
2014/0222099	A1	8/2014 Sweeney	WO	WO 2012/151364 A1	11/2012
2014/0236252	A1	8/2014 Ghosh et al.	WO	WO 2012/151389 A1	11/2012
2014/0276125	A1	9/2014 Hou et al.	WO	WO 2013/006724 A2	1/2013
2014/0277233	A1	9/2014 Ghosh	WO	WO 2013/010165 A1	1/2013
2014/0323882	A1	10/2014 Ghosh et al.	WO	WO 2013/010184 A1	1/2013
2014/0323892	A1	10/2014 Ghosh et al.	WO	WO 2013/006724 A3	4/2013
2014/0323893	A1	10/2014 Ghosh et al.	WO	WO 2014/179454 A1	11/2014
2014/0371807	A1	12/2014 Ghosh et al.	WO	WO 2014/179459 A2	11/2014
2014/0371808	A1	12/2014 Ghosh et al.	WO	WO 2014/179459 A3	1/2015
2014/0371832	A1	12/2014 Ghosh et al.	WO	WO 2015/013271 A1	1/2015
2014/0371833	A1	12/2014 Ghosh et al.	WO	WO 2015/013493 A1	1/2015
2015/0032016	A1	1/2015 Ghosh	WO	WO 2015013574 A1	1/2015
2015/0032171	A1	1/2015 Ghosh et al.			
2015/0032172	A1	1/2015 Ghosh			
2015/0032173	A1	1/2015 Ghosh			
2015/0045849	A1	2/2015 Ghosh et al.			
2015/0142069	A1	5/2015 Sambelashvili			
2015/0157225	A1	6/2015 Gillberg et al.			
2015/0157231	A1	6/2015 Gillberg et al.			
2015/0157232	A1	6/2015 Gillberg et al.			
2015/0157865	A1	6/2015 Gillberg et al.			
2015/0265840	A1	9/2015 Ghosh et al.			
2016/0030751	A1	2/2016 Ghosh et al.			
2016/0045737	A1	2/2016 Ghosh et al.			
2016/0045738	A1	2/2016 Ghosh et al.			
2016/0045744	A1	2/2016 Gillberg et al.			
2016/0184590	A1	6/2016 Ghosh			
2017/0049347	A1	2/2017 Ghosh et al.			
2017/0071675	A1	3/2017 Dawoud et al.			

OTHER PUBLICATIONS

Wang et al., "Application of the Method of Fundamental Solutions to Potential-based Inverse Electrocardiography", *Annals of Biomedical Engineering*, Aug. 2006.*

Miri et al., "Applicability of body surface potential map in computerized optimization of biventricular pacing", *Annals of Biomedical Engineering*, vol. 38, No. 3, Mar. 2010.*

Miri et al., "Computerized Optimization of Biventricular Pacing Using Body Surface Potential Map", 31st Annual International Conference of the IEEE EMBS, Sep. 2009.*

Miri et al., "Efficiency of Timing Delays and Electrode Positions in Optimization of Biventricular Pacing: A Simulation Study", *IEEE Transactions on Biomedical Engineering*, Nov. 2009.*

(56)

References Cited

OTHER PUBLICATIONS

- Liu et al., "Three-Dimensional Imaging of Ventricular activation and electrograms from intercavitary recordings", IEEE 2011.*
- Hurtado, "Electrical and anatomical modeling of the specialized cardiac conduction system. A simulation study", Universitat Politecnica de Valencia, 2011.*
- "Accuracy of Quadratic Versus Linear Interpolation in Noninvasive Electrocardiographic Imaging (ECGI)," by Subham Ghosh and Yoram Rudy, *Annals of Biomedical Engineering*, vol. 33, No. 9, Sep. 2005, pp. 1187-1201.
- "Cardiac resynchronization therapy in pediatric congenital heart disease: Insights from noninvasive electrocardiographic imaging," by Jennifer N.A. Silva, M.D., et al., *Heart Rhythm*, vol. 6, No. 8, Aug. 1, 2009, pp. 1178-1185.
- "Electrocardiographic imaging of cardiac resynchronization therapy in heart failure: Observation of variable electrophysiologic responses," by Ping Jia, Ph.D., et al., *Heart Rhythm*, vol. 3, No. 3, Mar. 1, 2006, pp. 296-310.
- "Method of Segmentation of Thorax Organs Images Applied to Modeling the Cardiac Electrical Field," by Alina Czerwinska et al., *Engineering in Medicine and Biology Society, Proceedings of the 22nd Annual International Conference of the IEEE*, vol. 1, 23, Jul. 23, 2000, pp. 402-405.
- "The Forward and Inverse Problems of Electrocardiography," by Ramesh M. Gulrajani, *IEEE Engineering in Medicine and Biology, IEEE Service Center*, vol. 17, No. 5, Sep. 1, 1988, pp. 84-101, 122.
- Ghosh et al., "Accuracy of Quadratic Versus Linear Interpolation in Non-Invasive Electrocardiographic Imaging (ECGI)," *Annals of Biomedical Engineering*, vol. 33, No. 9, Sep. 2005, pp. 1187-1201.
- Ghosh et al., "Application of the L1-Norm Regularization to Epicardial Potential Solution of the Inverse Electrocardiography Problem," *Annals of Biomedical Engineering*, vol. 37, No. 5, Sep. 2009, 11 pp.
- Kornreich, "Body surface potential mapping of ST segment changes in acute myocardial infarction," *Circulation* Apr. 1993; 87: pp. 773-782.
- Miri et al., "Applicability of body surface potential map in computerized optimization of biventricular pacing", *Annals of Biomedical Engineering*, vol. 38, No. 3, Mar. 2010, pp. 865-875.
- Miri et al., "Comparison of the electrophysiologically based optimization methods with different pacing parameters in patient undergoing resynchronization treatment", 30th Annual International IEEE EMBS Conference, Aug. 2008, pp. 1741-1744.
- Miri et al., "Computerized Optimization of Biventricular Pacing Using Body Surface Potential Map", 31st Annual International Conference of the IEEE EMBS, Sep. 2009, pp. 2815-2818.
- Miri et al., "Efficiency of Timing Delays and Electrode Positions in Optimization of Biventricular Pacing: A Simulation Study", *IEEE Transactions on Biomedical Engineering*, Nov. 2009, pp. 2573-2582.
- Modre, et al., "Noninvasive Myocardial Activation Time Imaging: A Novel Inverse Algorithm Applied to Clinical ECG Mapping Data," *IEEE Transactions on Biomedical Engineering*, vol. 49, No. 10, Oct. 2002, pp. 1153-1161.
- International Search Report and the Written Opinion from International Application No. PCT/US2012/036262, dated Mar. 11, 2013, 5 pp.
- Svendsen et al., "Computational Models of Cardiac Electrical Activation", Chapter 5, *Computational* Nov. 2010, pp. 73-88.
- Turner et al., "Electrical and mechanical components of dyssynchrony in heart failure patients with normal QRS duration and left bundle-branch block," *Circulation* Jul. 2004; 109; 2544-2549.
- Varma et al., "Pacebo CRT," *J Cardiovasc Electrophysiol*, vol. 19, Aug. 2008, p. 878.
- Wang et al., "Application of the Method of Fundamental Solutions to Potential-based Inverse Electrocardiography," *Annals of Biomedical Engineering*, Aug. 2006, pp. 1272-1288.
- Williams, et al., "Short-term hemodynamic effects of cardiac resynchronization therapy in patients with heart failure, a narrow QRS duration and no dyssynchrony," *Circulation* Oct. 2009; 120: 1687-1694.
- Office Action from Chinese Application No. 201280024669.3, dated Dec. 16, 2014, 17 pp.
- Response to Chinese Office Action dated Dec. 16, 2014 from Chinese Application No. 201280024669.3, filed Apr. 28, 2015, 23 pp.
- Office Action from Chinese Application No. 201280026661.0, dated Dec. 11, 2014, 12 pp.
- Prosecution History from U.S. Appl. No. 13/462,404, dated Jul. 18, 2013 through Mar. 12, 2015, 106 pp.
- Prosecution History from U.S. Appl. No. 13/462,480, dated Jul. 3, 2014 through Oct. 22, 2014, 34 pp.
- Response to Office Action dated Mar. 12, 2015, from U.S. Appl. No. 13/462,404, filed Jun. 11, 2015, 7 pp.
- Examination Report from counterpart European Application No. 12720386.7, dated Feb. 5, 2015, 5 pp.
- Examination Report from counterpart European Application No. 12720386.7, dated Mar. 15, 2016, 4 pp.
- Biffi et al., "Occurrence of Phrenic Nerve Stimulation in Cardiac Resynchronization Therapy Patients: the Role of Left Ventricular Lead Type and Placement Site," *Europace*, Jul. 29, 2012, 15:77-82.
- Botker MD, Ph.D., et al., "Electromechanical Mapping for Detection of Myocardial Viability in Patients with ischemia Cardiomyopathy," *Circulation*, Mar. 2001; vol. 103, No. 12, pp.
- "CardioGuide System Enables Real-Time Navigation of Left Ventricular Leads During Medtronic CRT Implants," Press Release, Apr. 9, 2013, Medtronic, Inc., 2 pgs.
- Cuculich, P.S., et al., "The Electrophysiological Cardiac Ventricular Substrate in Patients After Myocardial Infection" *J. Am. Coll. Cardiol.* Nov. 28, 2011; 58:1893-1902.
- Dawoud, F. et al., "Inverse Electrocardiographic Imaging to Assess Electrical Dyssynchrony in Cardiac Resynchronization Therapy Patients," *Computing in Cardiology*, Sep. 2012; 39:993-996.
- Freund et al., "A Decision-Theoretic Generalization of On-line Learning and an Application to Boosting," *Journal of Computer and System Sciences*, Dec. 1996; 55(1):119-139.
- Friedman, "Greedy Function Approximation: A Gradient Boosting Machine," *Annals of Statistics*, Oct. 2001; 29(5):1189-1232.
- Friedman, "Stochastic Gradient Boosting," *Computational Statistics and Data Analysis*, Feb. 2002; 38(4):367-378.
- Friedman et al., "Additive Logistic Regression: a Statistical View of Boosting," *Annals of Statistics*, Apr. 2000; 28(2):337-374.
- Ghosh et al., "Cardiac Memory in Patients with Wolff-Parkinson-White Syndrome: Noninvasive Imaging of Activation and Repolarization Before and After Catheter Ablation," *Circulation*, Aug. 12, 2008; 118:907-915.
- Ghosh et al., "Electrophysiological Substrate and Intraventricular LV Dyssynchrony in Non-ischemic Heart Failure Patients Undergoing Cardiac Resynchronization Therapy," *Heart rhythm : the official journal of the Heart Rhythm Society*, Jan. 2011; 8(5):692-699.
- Gold et al., "Comparison of Stimulation Sites within Left Ventricular Veins on the Acute Hemodynamic Effects of Cardiac Resynchronization Therapy," *Heart Rhythm*, Apr. 2005; 2(4):376-381.
- Hansen, "Regularization Tools: A Matlab Package for Analysis and Solution of Discrete Ill-Posed Problems," Version 4.1 for Matlab 7.3; Mar. 2008; 128 pages. Retrieved from the Internet: Jun. 19, 2014 <http://www.mathworks.com/matlabcentral/fileexchange/52-regtools>.
- Hayes et al., "Cardiac Resynchronization Therapy and the Relationship of Percent Biventricular Pacing to Symptoms and Survival," *Heart Rhythm*, Sep. 2011; 8(9):1469-1475.
- "Heart Failure Management" datasheet [online]. Medtronic, Minneapolis, Minnesota, [Last updated on Jun. 3, 2013]. Retrieved from the Internet: www.medtronic.com; 9 pages.
- Hopenfeld et al., "The Effect of Conductivity on ST-Segment Epicardial Potentials Arising from Subendocardial Ischemia," *Annals of Biomedical Eng.*, Jun. 2005; vol. 33, No. 6, pp. 751-763.

(56)

References Cited

OTHER PUBLICATIONS

- Medtronic Vitatron Carelink Encore® Programmer Model 29901 Reference Manual, Jan. 29, 2013, 21 pp. Medtronic, Inc., Minneapolis, MN.
- Nash et al., "An Experimental-Computational Framework for Validating in-vivo ECG Inverse Algorithms," *International Journal of Bioelectromagnetism*, vol. 2, No. 2, Dec. 31, 2000, 9 pp.
- Potse et al., "Mathematical Modeling and Simulation of Ventricular Activation Sequences: Implications for Cardiac Resynchronization Therapy," *J. of Cardiovasc. Trans. Res.*, Jan. 27, 2012; 5:146-158.
- Prinzen et al., "Cardiac Resynchronization Therapy State-of-the-Art of Current Applications, Guidelines, Ongoing Trials, and Areas of Controversy", *Circulation*, Nov. 26, 2013; 128: 2407-2418.
- Ridgeway, "The State of Boosting," *Computing Science and Statistics*, 1999; 31:172-181. (Applicant points out, in accordance with MPEP 609.04(a), that the year of publication, 1999, is sufficiently earlier than the effective U.S. filing date, May 2, 2012 so that the particular month of publication is not in issue.)
- Ryu et al., "Simultaneous Electrical and Mechanical Mapping Using 3D Cardiac Mapping System: Novel Approach for Optimal Cardiac Resynchronization Therapy," *Journal of Cardiovascular Electrophysiology*, Feb. 2010; 21(2):219-22.
- Singh et al., "Left Ventricular Lead Position and Clinical Outcome in the Multicenter Automatic Defibrillator Implantation Trial-Cardiac Resynchronization Therapy (MADIT-CRT) Trial," *Circulation*, Mar. 22, 2011; 123:1159-1166.
- Sperzel et al., "Intraoperative Characterization of Interventricular Mechanical Dyssynchrony Using Electroanatomic Mapping System—A Feasibility Study," *Journal of Interventional Cardiac Electrophysiology*, Nov. 2012; 35(2):189-96.
- Steinhaus BM., "Estimating cardiac transmembrane activation and recovery times from unipolar and bipolar extracellular electrograms: a simulation study," *Circulation Research*, Mar. 1989, 64:449-462.
- Strik et al., "Electrical and Mechanical Ventricular Activation During Left Bundle Branch Block and Resynchronization," *J. Of Cardiovasc. Trans. Res.*, Feb. 7, 2012; 5:117-126.
- Sweeney et al., "Analysis of Ventricular Activation Using Surface Electrocardiography to Predict Left Ventricular Reverse Volumetric Remodeling During Cardiac Resynchronization Therapy," *Circulation*, Feb. 9, 2010; 121(5):626-34.
- Van Deursen et al., "Vectorcardiography as a Tool for Wasy Optimization of Cardiac Resynchronization Therapy in Canine LBBB Hearts," *Circulation Arrhythmia and Electrophysiology*, Jun. 1, 2012; 5(3):544-52.
- Vardas et al., The Task Force for Cardiac Pacing and Cardiac Resynchronization Therapy of the European Society of Cardiology. Developed in Collaboration with the European Heart Rhythm Association, *European Heart Journal*, Aug. 2007; 28:2256-2295.
- Wellens, MD et al., "The Electrocardiogram 102 Years After Einthoven," *Circulation*, Feb. 2004; vol. 109, No. 5, pp. 562-564.
- Fung, et al., "Chapter 20, Optimization of Cardiac Resynchronization Therapy," *Cardiac Resynchronization Therapy*, Second Edition, Jan. 2009, pp. 356-373.
- Sweeney, et al., "QRS Fusion Complex Analysis Using Wave Interference to Predict Reverse Remodeling During Cardiac Resynchronization Therapy," *Heart Rhythm*, May 2014, 11: 806-813.
- Notice of Allowance from U.S. Appl. No. 13/462,404, dated Jul. 29, 2016, 7 pp.
- Notice of Allowance from U.S. Appl. No. 13/462,404, dated Aug. 10, 2016, 4 pp.
- Communication pursuant to Article 94(3) EPC from counterpart European Application No. 12720386.7, dated Apr. 20, 2017, 3 pp.
- Response to Communication dated Apr. 20, 2017, from counterpart European Application No. 12720386.7, filed Aug. 28, 2017, 7 pp.
- Office Action from U.S. Appl. No. 15/345,225, dated Jun. 12, 2017, 16 pp.
- Response to Office Action dated Jun. 12, 2017, from U.S. Appl. No. 15/345,225, filed Sep. 12, 2017, 19 pp.
- International Preliminary Report on Patentability from International Application No. PCT/US2012/036302, dated Nov. 5, 2013, 5 pp.
- Preliminary Amendment in counterpart European Patent Application No. EP 12720386.7, filed on Nov. 28, 2013, 11 pp.
- Response to Communication dated Feb. 5, 2015, from counterpart European Patent Application No. EP 12720386.7, filed on Aug. 11, 2015, 2 pp.
- Response to Communication dated Oct. 24, 2016, from counterpart European Patent Application No. EP 12720386.7, filed on Jan. 3, 2017, 5 pp.
- Notice of Allowance from U.S. Appl. No. 15/345,225, dated Jan. 4, 2018, 7 pp.
- Corrected Notice of Allowability from U.S. Appl. No. 15/345,225, dated Jan. 18, 2018, 4 pp.

* cited by examiner

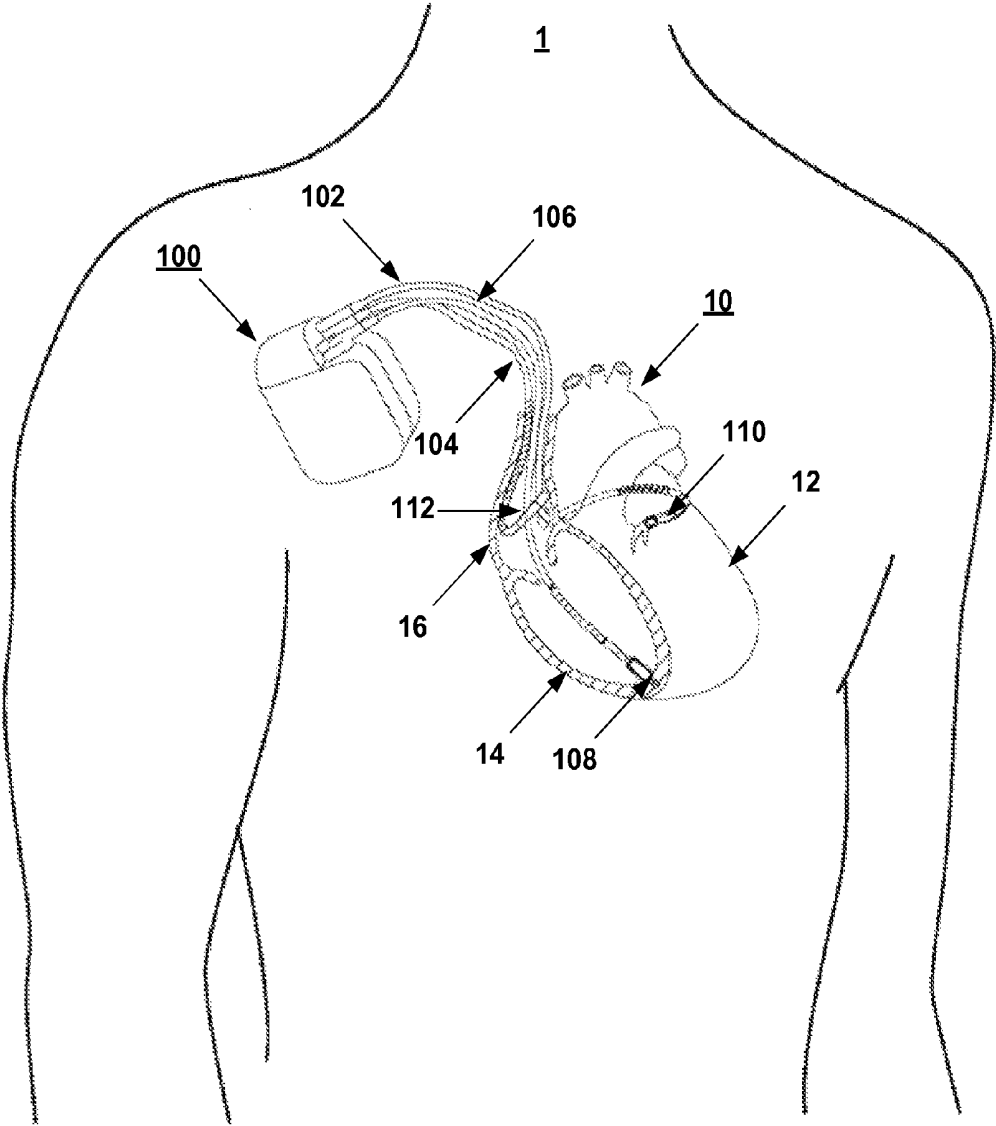

FIG. 1

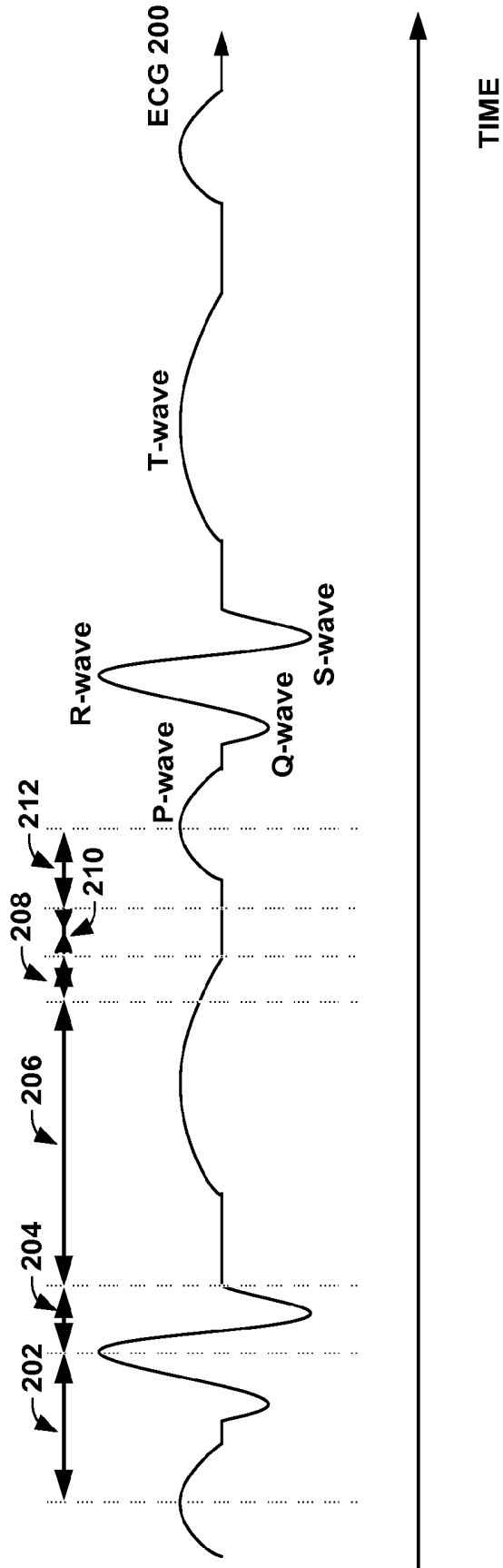

FIG. 2

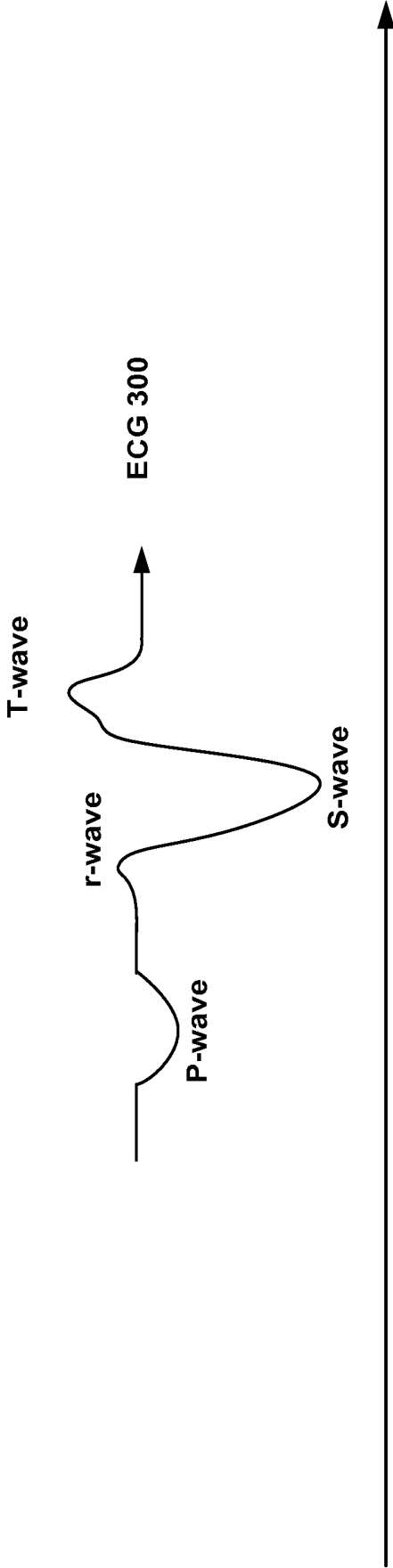

FIG. 3

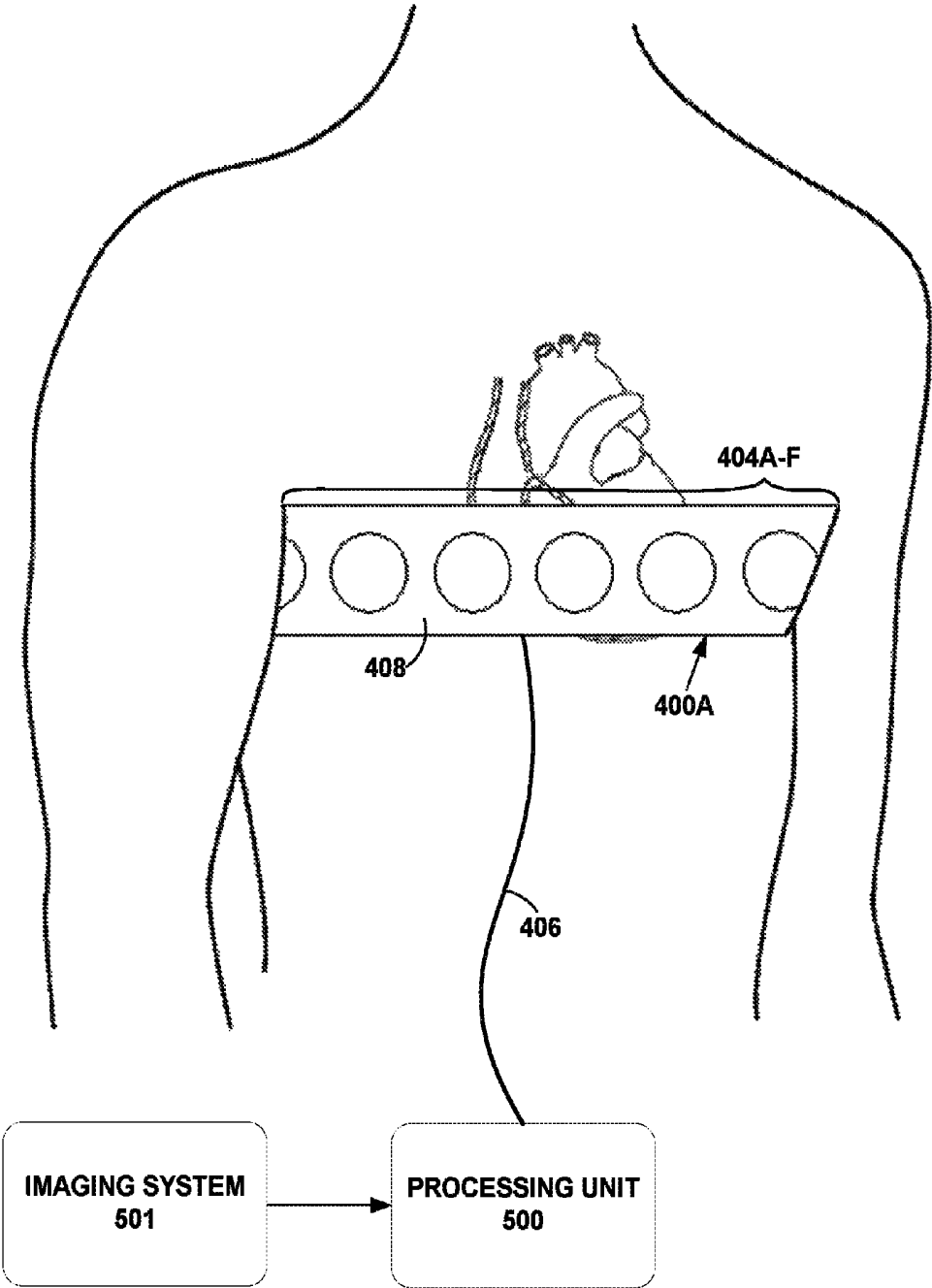

FIG. 4A

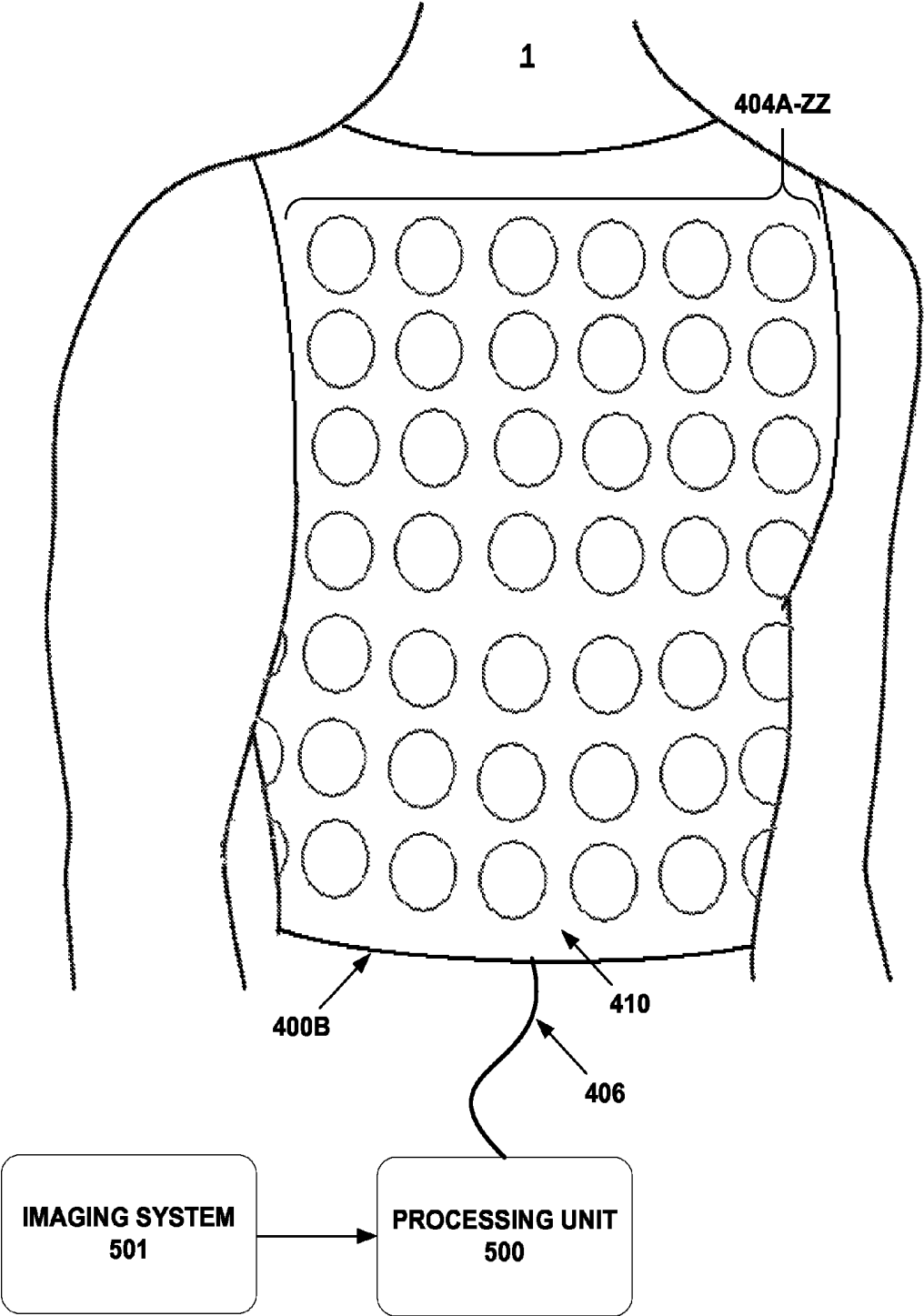

FIG. 4B

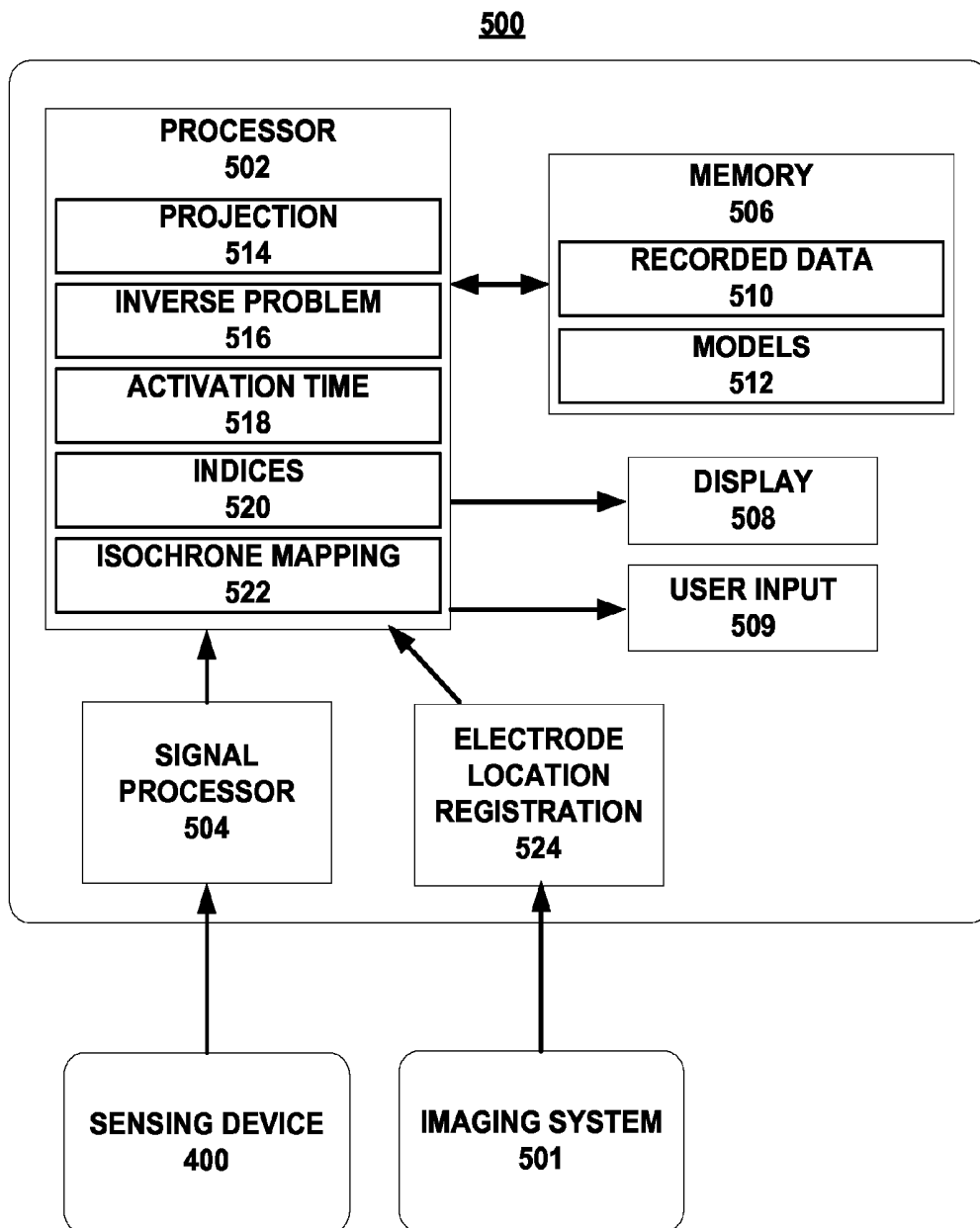

FIG. 5

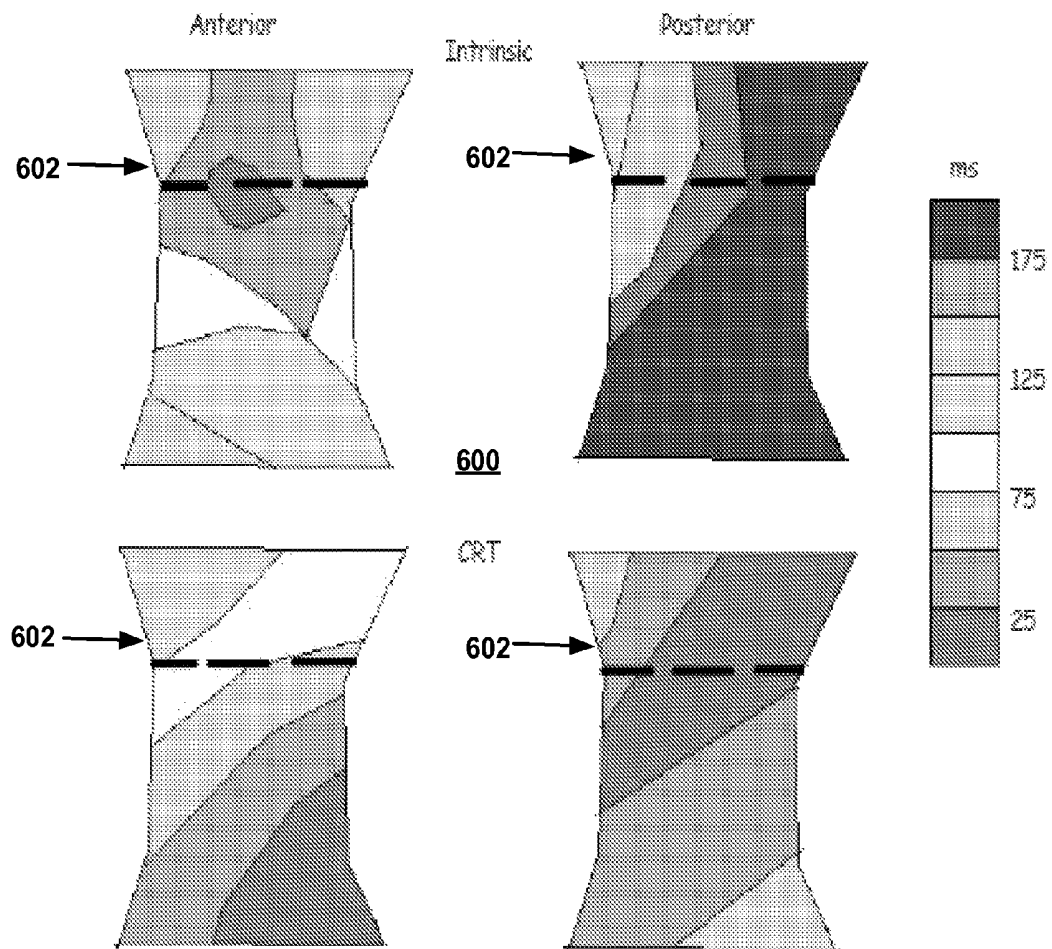

FIG. 6

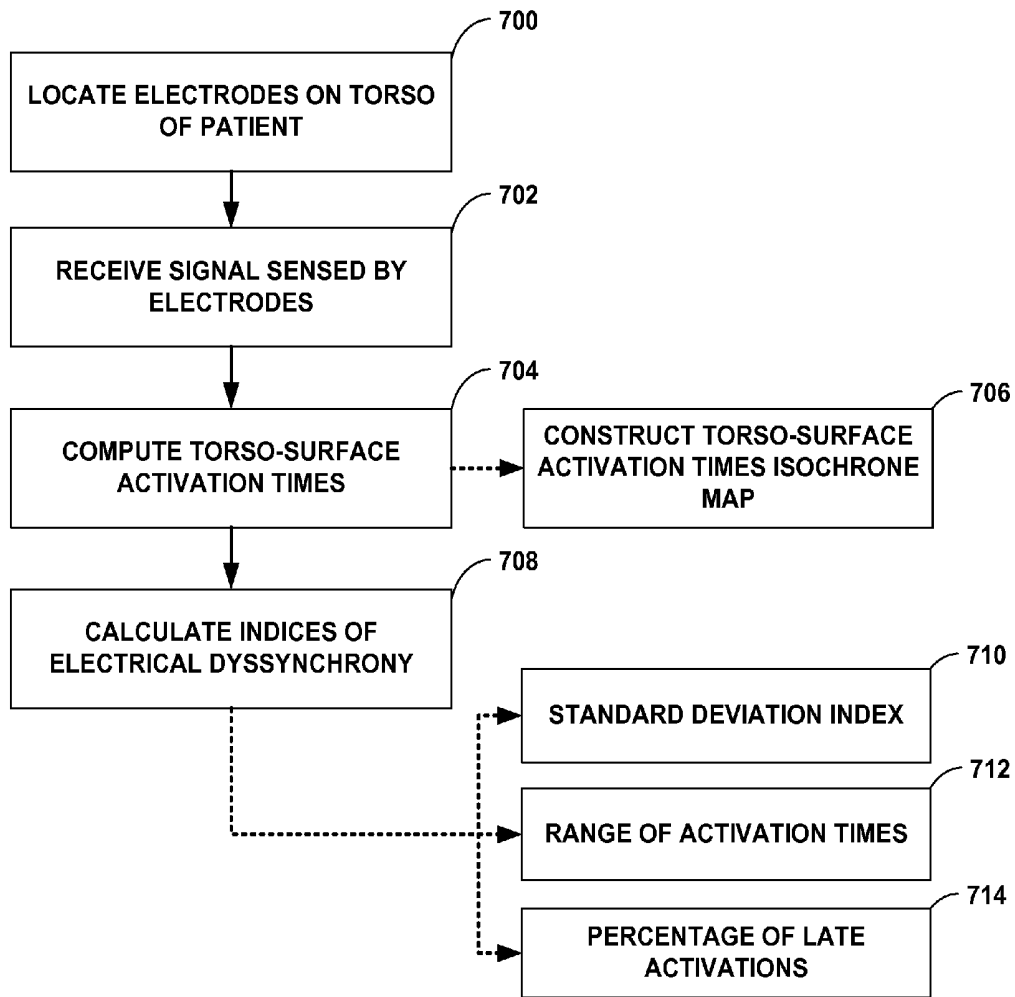

FIG. 7

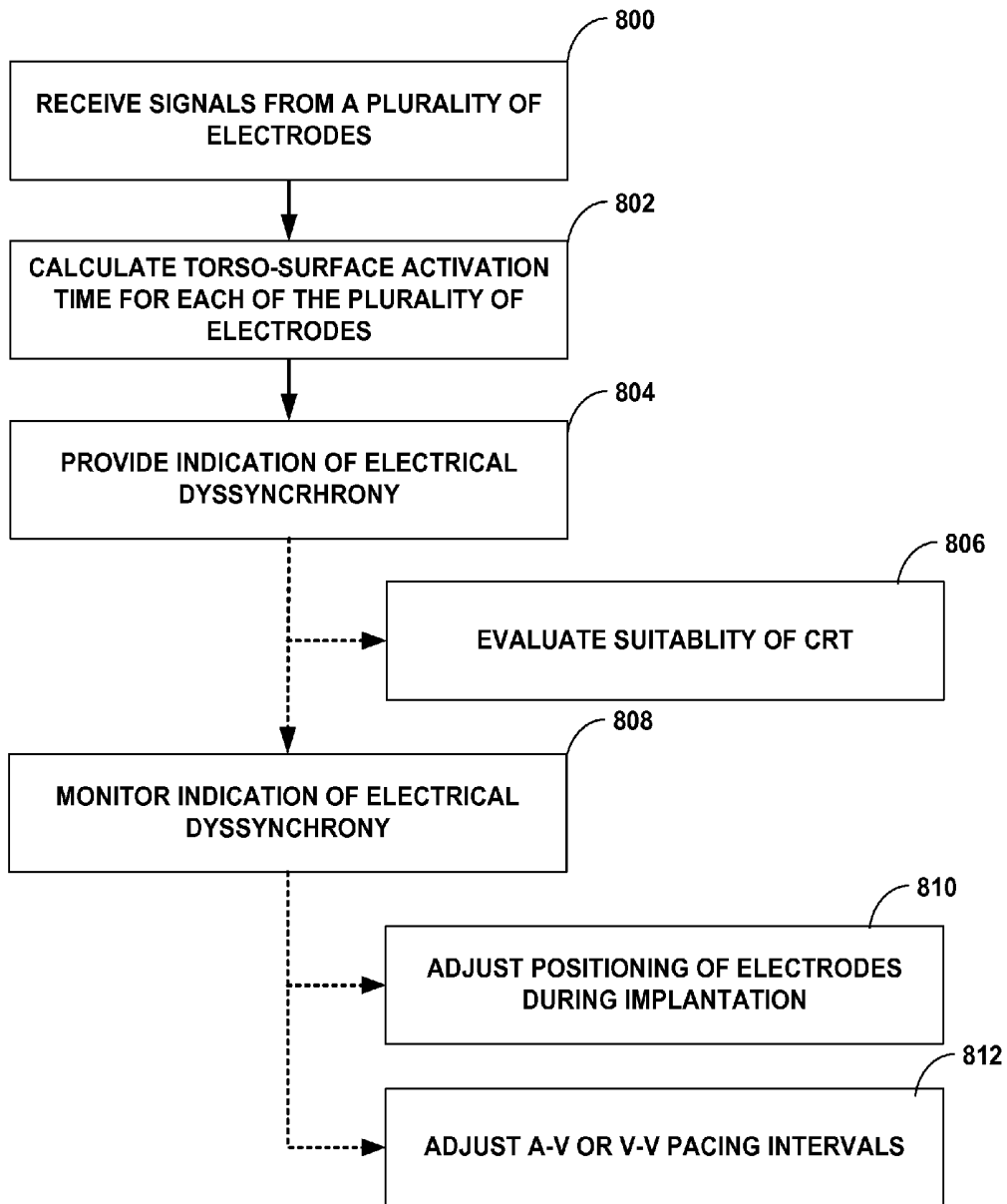

FIG. 8

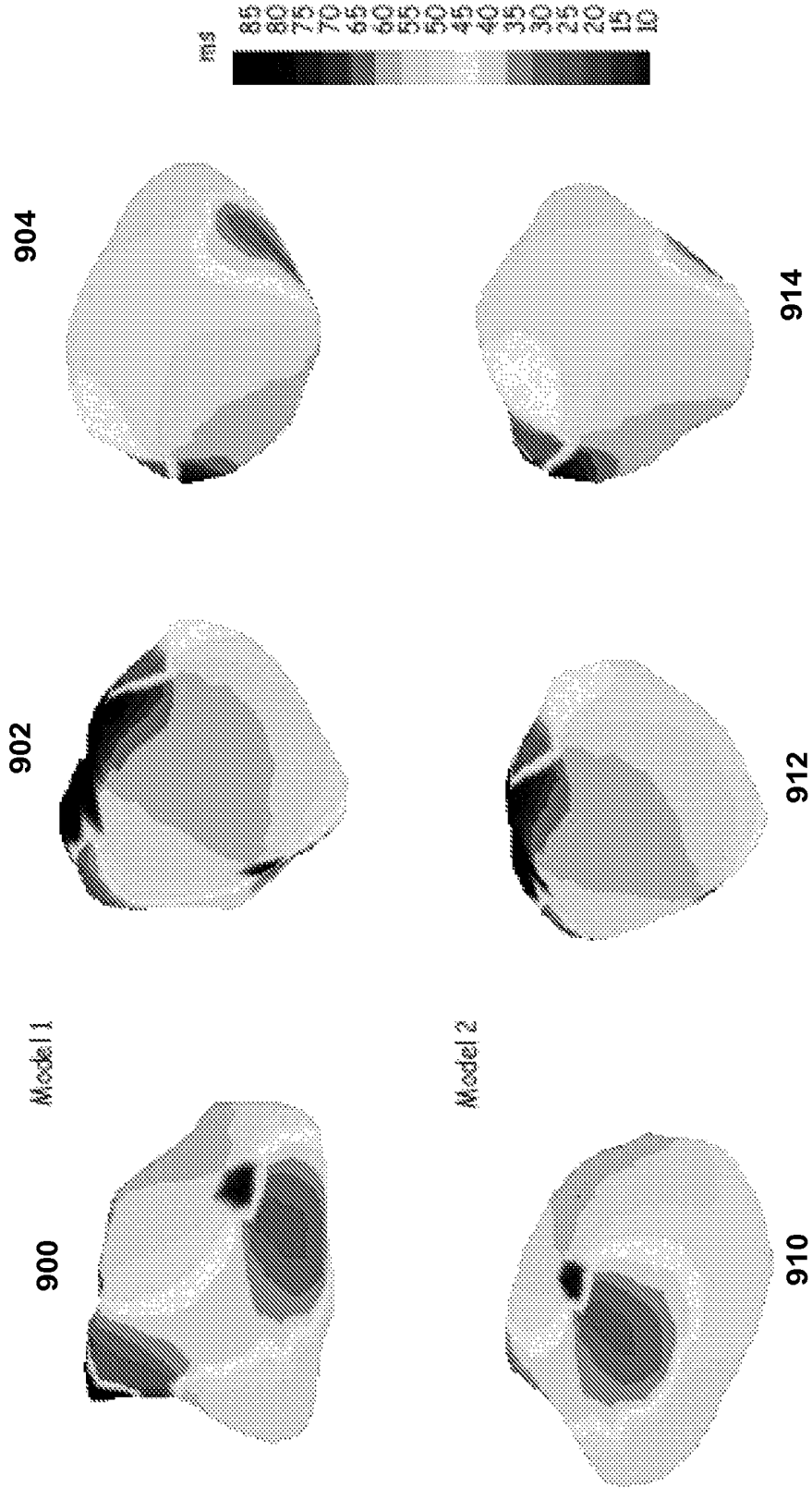

FIG. 9

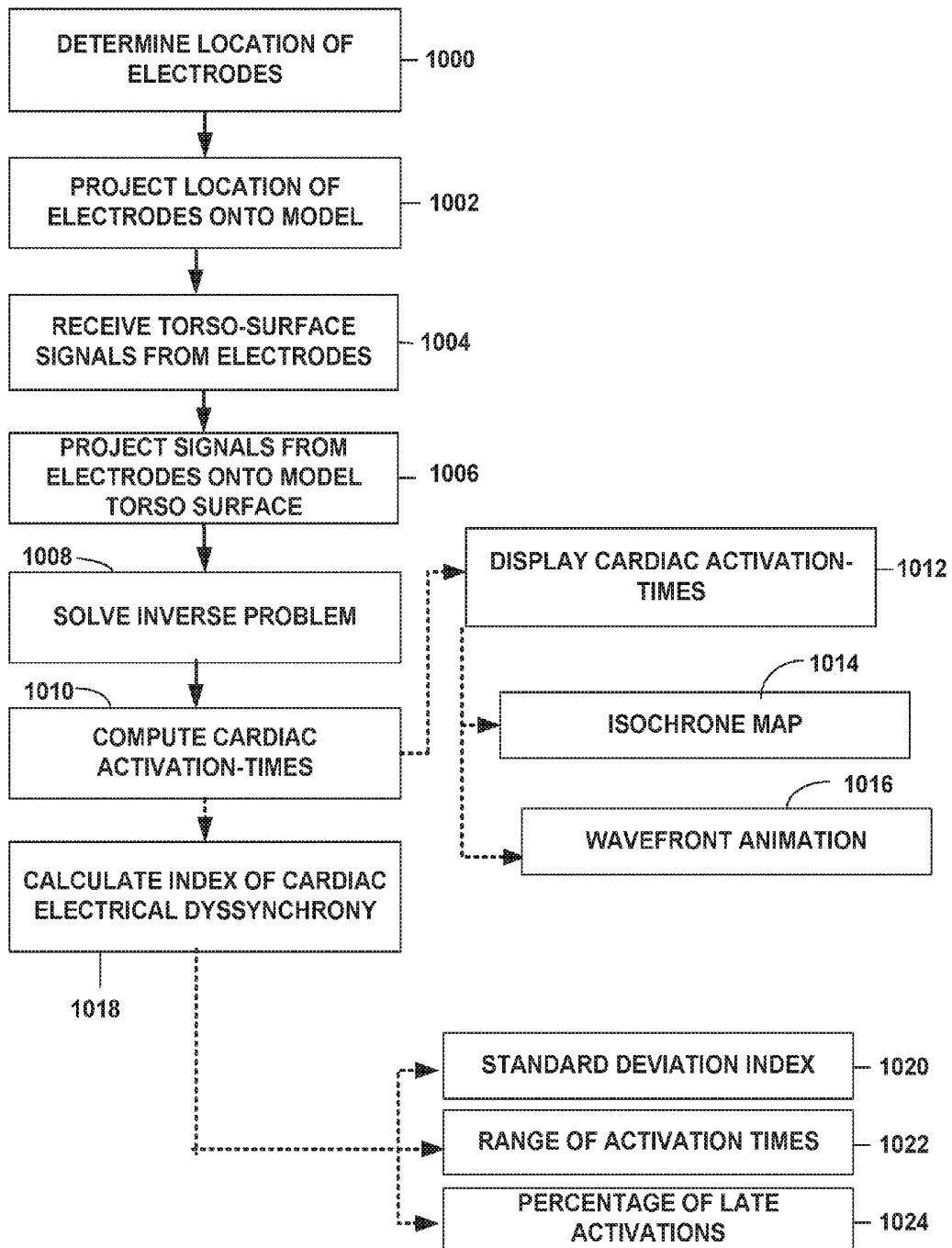

FIG. 10

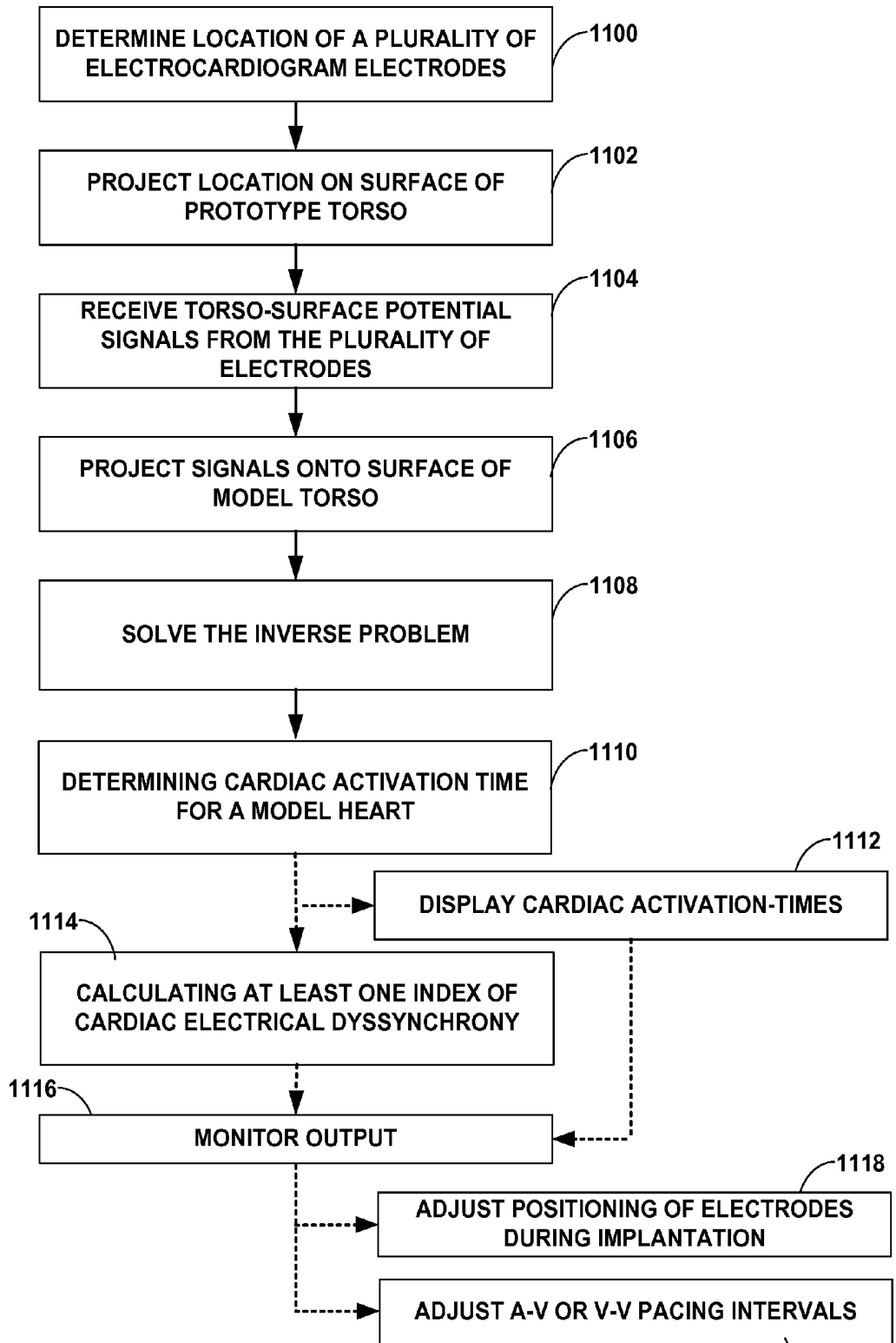

FIG. 11

1120

ASSESSING INTRA-CARDIAC ACTIVATION PATTERNS

CROSS-REFERENCE TO RELATED APPLICATIONS

This application is a continuation of U.S. application Ser. No. 13/462,480, which was filed on May 2, 2012, is issuing as U.S. Pat. No. 8,972,228 on Mar. 3, 2015, and claims the benefit of U.S. Provisional Application No. 61/482,053 filed on May 3, 2011, the entire content of each of which is incorporated herein by reference.

TECHNICAL FIELD

The disclosure relates to electrophysiology and, more particularly, to evaluating the electrical activation patterns of the heart.

BACKGROUND

The beat of the heart is controlled by the sinoatrial node, a group of conductive cells located in the right atrium near the entrance of the superior vena cava. The depolarization signal generated by the sinoatrial node activates the atrioventricular node. The atrioventricular node briefly delays the propagation of the depolarization signal, allowing the atria to drain, before passing the depolarization signal to the ventricles of the heart. The coordinated contraction of both ventricles drives the flow of blood through the torso of a patient. In certain circumstances, the conduction of the depolarization signal from the atrioventricular node to the left and right ventricles may be interrupted or slowed. This may result in a dyssynchrony in the contraction of the left and right ventricles, and eventually in heart failure or death.

Cardiac Resynchronization Therapy (CRT) may correct the symptoms of electrical dyssynchrony by providing pacing therapy to one or both ventricles or atria, e.g., by providing pacing to encourage earlier activation of the left or right ventricles. By pacing the contraction of the ventricles, the ventricles may be controlled so that the ventricles contract in synchrony. Some patients undergoing CRT have experienced improved ejection fraction, increased exercise capacity, and an improved feeling of well-being.

Providing CRT to a patient may involve determining whether the patient will derive benefit from the CRT prior to implantation of a cardiac rhythm device, determining optimal site for placement of one or more ventricular pacing leads, and programming of device parameters, such as selection of electrodes on multi-polar right or left ventricular leads, as well as selection of the timing of the pacing pulses delivered to the electrodes, such as atrioventricular (A-V) and intra-ventricular (V-V) delays. Assessment of electrical dyssynchrony for these purposes has typically involved assessing QRS duration clinically. Though CRT is recommended typically for patients with wide QRS duration, hemodynamic improvements through CRT have been reported in narrow QRS heart failure patients. Thus, some patients who may benefit from CRT may not be prescribed CRT based on present electrical dyssynchrony evaluation techniques.

SUMMARY

In general, the disclosure is directed towards techniques for evaluating electrical dyssynchrony of the heart of a patient. The evaluation of electrical dyssynchrony may

facilitate patient selection for CRT. The evaluation of electrical dyssynchrony may also facilitate placement of implantable leads, e.g., one or more left ventricular leads, and programming of device parameters for CRT during an implantation procedure, or reprogramming of device parameters for CRT during a follow-up visit.

A set of electrodes may be spatially distributed about the torso of a patient. The electrodes may each sense a body-surface potential signal, and more particularly a torso-surface potential signal, which indicates the depolarization signals of the heart of the patient after the signals have progressed through the torso of the patient. Due to the spatial distribution of the electrodes, the torso-surface potential signal recorded by each electrode may indicate the depolarization of a different spatial region of the heart.

In some examples, an activation time is determined for each torso-surface potential signal, i.e., for each electrode of the set. The dispersion or sequence of these activation times may be analyzed or presented to provide variety of indications of the electrical dyssynchrony of the heart of the patient. For example, isochrone or other activation maps of the torso-surface illustrating the activation times may be presented to user to illustrate electrical dyssynchrony of the heart. In some examples, values of one or more statistical indices indicative of the temporal and/or spatial distribution of the activation times may be determined. Such maps and indices, or other indications of dyssynchrony determined based on the torso-surface activation times, may indicate electrical dyssynchrony of the heart to a user, and facilitate evaluation of a patient for CRT, and configuration of CRT for the patient.

In some examples, the locations of all or a subset of the electrodes, and thus the locations at which the torso-surface potential signals were sensed, may be projected on the surface of a model torso that includes a model heart. The inverse problem of electrocardiography may be solved to determine electrical activation times for regions of the model heart based on the torso-surface potential signals sensed from the patient. In this manner, the electrical activity of the heart of the patient may be estimated. Various isochrone or other activation time maps of the surface of the model heart may be generated based on the torso-surface potential signals sensed on the surface of the torso of the patient. Further, values of one or more indices indicative of the temporal and/or spatial distribution of the activation times on model heart may be determined. These measures and representations of electrical dyssynchrony may be used to evaluate the suitability of the patient for CRT, adjust the positioning of the CRT leads during implantation, and determine which electrodes of one or more multi-polar leads should be utilized for delivery of CRT, as well as the timing of pacing pulses, such as atrio-ventricular (A-V) and intra-ventricular (V-V) delays for delivery of CRT to the patient.

For example, the one or more indications of dyssynchrony may be determined or generated based on data collected both during intrinsic conduction and during CRT. The degree of dyssynchrony during intrinsic conduction and CRT may be compared, e.g., to determine whether a patient is a candidate for CRT. Similarly, the one or more indications of dyssynchrony may be determined or generated based on data collected during CRT with different lead positions, different electrode configurations, and/or different CRT parameters, e.g., A-V or V-V delay. The change in dyssynchrony attributable to these different lead positions, different electrode configurations, and/or different CRT parameters may be evaluated.

In one example, a method comprises receiving, with a processing unit, a torso-surface potential signal from each of a plurality of electrodes distributed on a torso of a patient. The method further comprises for at least a subset of the plurality of electrodes, calculating, with the processing unit, a torso-surface activation time based on the signal sensed from the electrode, and presenting, by the processing unit, to a user, an indication of a degree of dyssynchrony of the torso-surface activation times via a display.

In another example, a system comprises a plurality of electrodes distributed on a torso of a patient, and a processing unit. The processing unit is configured to receive a torso-surface potential signal from each of the plurality of electrodes, calculate, for at least a subset of the plurality of electrodes, a torso-surface activation time based on the signal sensed from the electrode, and present, to a user, an indication of a degree of dyssynchrony of the torso-surface activation times via a display.

In another example a computer-readable storage medium comprises instructions that, when executed, cause a processor to receive a torso-surface potential signal from each of a plurality of electrodes distributed on a torso of a patient, calculate, for at least a subset of the plurality of electrodes, a torso-surface activation time based on the signal sensed from the electrodes, and present to a user, an indication of a degree of dyssynchrony of the torso-surface activation times via a display.

The details of one or more aspects of the disclosure are set forth in the accompanying drawings and the description below. Other features, objects, and advantages will be apparent from the description and drawings, and from the claims.

BRIEF DESCRIPTION OF DRAWINGS

FIG. 1 is a conceptual diagram illustrating an example system that may be used to provide CRT to a heart of a patient.

FIG. 2 is a timing diagram showing an example ECG tracing of two healthy heart beats.

FIG. 3 is a timing diagram showing an example ECG tracing of a patient suffering from left bundle branch block.

FIGS. 4A and 4B are conceptual diagrams illustrating example systems for measuring torso-surface potentials.

FIG. 5 is a block diagram illustrating an example system for measuring torso-surface potentials.

FIG. 6 is a series of simulated isochrone maps of torso-surface activation times for typical left bundle branch block intrinsic rhythm and CRT pacing.

FIG. 7 is a flow diagram illustrating an example operation of a system to provide indications of the cardiac electrical dyssynchrony of a patient based on torso-surface activation times.

FIG. 8 is a flow diagram illustrating an example technique for prescribing and configuring CRT based on an assessment cardiac electrical dyssynchrony of a patient via the torso-surface activation times.

FIG. 9 is a series of isochrone maps of cardiac activation times constructed with two different heart-torso models using body-surface ECG data from the same patient.

FIG. 10 is a flow diagram illustrating an example operation of a system to measure the cardiac electrical dyssynchrony of a patient via the cardiac activation times.

FIG. 11 is a flow diagram illustrating an example technique for configuring CRT based on an assessment of cardiac electrical dyssynchrony of a patient via the cardiac activation times.

DETAILED DESCRIPTION

FIG. 1 is a conceptual diagram illustrating an example system that may be used to provide CRT to heart 10 of patient 1. The system may include an implantable medical device (IMD) 100. IMD 100 may be a CRT pacemaker or CRT defibrillator. IMD 100 may be equipped with one or more leads; leads 102, 104, and 106; that are inserted into or on the surface of the left ventricle 12, right ventricle 14, or right atrium 16 of heart 10. Leads 102, 104, and 106 may be equipped with one or more electrodes 108, 110, and 112.

Heart 10 may suffer from an electrical dyssynchrony. Electrical dyssynchrony may occur when the depolarization signals that start the contraction of ventricles 12 and 14 do not reach the ventricles in a coordinated manner, and results in an inefficient pumping action of heart 10. Patient 1 may experience symptoms of heart failure. Electrical dyssynchrony may be caused by damage to the electrical system of heart 10, e.g., a bundle branch block or damage to the fascicle of heart 10. Alternate conduction pathways may form within heart 10, but these pathways may slow the progress of the electrical depolarization signal and result in the asynchronous contraction of ventricles 12 and 14.

IMD 100 may provide CRT stimulation to heart 10 of patient 1. IMD 100 is depicted as being configured to deliver stimulation to right atrium 16, right ventricle 14, and left ventricle 12 of heart 10. In other examples, IMD 100 may be configured to deliver stimulation to other portions of heart 10 depending on the condition of patient 1. IMD 100 may interact with an external programmer (not shown) to adjust operating characteristics, such as A-V and V-V delays, of the therapy delivered by IMD 100. In some examples, IMD 100 may also be configured to sense the electrical activity of heart 10 through the electrodes on one or more of leads 102, 104, and 106.

As shown in FIG. 1, leads 102, 104, 106 may extend into the heart 10 of patient 1 to deliver electrical stimulation to heart 10 and synchronize the contraction of ventricles 12 and 14. Right ventricular lead 106 extends through one or more veins (not shown), the superior vena cava (not shown), and right atrium 16, and into right ventricle 14. Left ventricular coronary sinus lead 102 extends through one or more veins, the vena cava, right atrium 16, and into the coronary sinus (not shown) to a region adjacent to the free wall of left ventricle 12 of heart 10. Right atrial lead 104 extends through one or more veins and the vena cava, and into the right atrium 16 of heart 10.

In other configurations, IMD 100 may be equipped with more or fewer leads, depending on the requirements of the therapy provided to patient 1. For example, IMD 100 may be equipped with leads that extend to greater or fewer chambers of heart 10. In some example, IMD 100 may be equipped with multiple leads that extend to a common chamber of heart, e.g., multiple leads extending to the left ventricle 12. IMD 100 may also be equipped with one or more leads that are placed on the heart through other means providing access to the cardiac tissue, such as surgical epicardial lead placement, and other pericardial access approaches. In some examples, IMD 100 may be equipped with a left ventricular lead that is placed on the heart endocardially. Additionally, although illustrated as implanted on the right side of patient 1 in FIG. 1, IMD 100 may in other examples be implanted on the left side of the pectoral region of the patient, or within the abdomen of the patient.

Electrodes 108, 110, and 112 may attach to portions of heart 10 to provide electrical stimulation or sense the electrical depolarization and repolarization signals of heart

10. Electrode **108**, in right ventricle **14**, may be affixed to the wall of heart **10** via a screw based mechanism. Electrode **110** may comprise multiple electrodes mounted the same lead, allowing lead **102** to both transmit therapeutic shocks as well as electrical sense data detected by electrode **110**. Electrodes **110** and **112** may be attached to the surface of heart **10** via glue, barbs, or another permanent or semi-permanent attachment mechanism.

FIG. **2** is a timing diagram showing an example ECG tracing **200** in conjunction with certain periods or phases of the mechanical cardiac cycle. The depiction and associated description of FIG. **2** are generalized in the sense that the relationship between the timing of electrical and mechanical events is not necessarily as described for all subjects, or at all times for any given subject.

ECG tracing **200** depicts the electrical signal of two example healthy cardiac cycles. The electrical signal of a healthy heart comprises a series of 5 characteristic waves: the P-wave, Q-wave, R-wave, S-wave, and T-wave. Each of these waves, and the intervals between them, correspond to discrete events in the functioning of a healthy heart.

In general, at some point during period **202**, which stretches from the peak of a P-wave to the peak of the subsequent R-wave, atrial systole occurs, which is the contraction of the atria that drives blood from the atria into the ventricles. Period **204**, from the peak of the R-wave to the opening of the aortic valve, generally marks a period of isovolumetric contraction. The atrioventricular and aortic valves are closed, preventing blood flow and leading to an increase in pressure in the ventricles but not yet in the aorta. Period **206**, bounded by the opening and closing of the aortic valves is generally when ejection occurs during the cardiac cycle. During ejection period **206** the ventricles contract and empty of blood, driving the blood into cardiovascular system. As the contraction of the ventricles complete, the pressure of the blood within the cardiovascular system closes the aortic valves. Period **208**, bounded by the closing of the aortic valves and the opening of the atrioventricular valves, is the isovolumetric relaxation of the ventricles. Periods **210** and **212** are collectively known as the late diastole, where the whole heart relaxes and the atria fill with blood. Period **210** corresponds to a rapid inflow of blood while period **212** corresponds to diastasis, the period of slower flow blood into the atria before the atrial systole **202** occurs again.

The P-wave marks the stimulation of the atria and the beginning of the cardiac cycle. The atria contract under the stimulation, forcing blood into the ventricles. The PR segment marks the delay as the depolarization signal travels from the atrioventricular node to the Purkinje fibers. The Q-wave marks the depolarization of the interventricular septum as an initial part of the depolarization of the ventricles. The R-wave follows the Q-wave and represents the depolarization of the ventricles. The S-wave follows the R-wave and represents the later depolarization of the ventricles. The T-wave marks the recovery and repolarization of the ventricles in preparation for the next beat of the heart.

The QRS complex, spanning from the beginning of the Q-wave to the end of the S-wave, represents the electrical activation of the myocardium. Ventricular contraction of both the left and right ventricles is in response to the electrical activation. The QRS complex typically lasts from 80 to 120 ms. The relatively large amplitude of the QRS complex is due to the large muscle mass of the ventricles. Issues affecting the synchrony of the ventricular contraction may be demonstrated in the deformation of the QRS complex. For example, electrical dyssynchrony in the contrac-

tion of the ventricles can widen the R-wave or produce two R-wave peaks, typically labeled the r-wave and R'-wave, corresponding to the depolarization of each ventricle. The S-wave and the T-wave may be morphologically different than in an ECG tracing of a healthy heart.

FIG. **3** is a timing diagram showing ECG tracing **300**. ECG tracing **300** depicts the electrical signal of a patient suffering from a left bundle branch block. A sign of the condition is the presence of an rS complex versus the typical QRS complex, though other variations of Q, R, and S wave form combinations that may be present in patients suffering from a left bundle branch block, right bundle branch blocks, or other ventricular conduction conditions. The extended duration of the rS complex indicates an extended ventricular contraction time, likely due to electrical dyssynchronies.

Diagnosis of a left or right bundle branch block, or cardiac electrical dyssynchrony in general, typically involves measuring the duration of the QRS complex (or other complex marking the depolarization of the ventricles). QRS complexes lasting 100 ms or longer may indicate a partial bundle branch block and 120 ms or longer a complete bundle branch block. In FIG. **3**, the initial Q-wave is not visible, instead the tracing shows an initial r-wave, corresponding to the initial depolarization of the right ventricle and followed by an S-wave marking the rapid depolarization of both ventricles after the cardiac signal has reached the left ventricle after traveling through the myocardium of the heart, rather than through the bundle branches. Because the myocardium conducts electricity more slowly than the bundle branches, the entire complex is spread out over a longer period.

Absent a case of bundle branch block—such as the one shown in FIG. **3**—or other condition, diagnosis may be more challenging. Occult dyssynchronies may be present that, while responsive to CRT, may not be readily identifiable from an examination of the typical 12-lead ECG. These occult dyssynchronies may manifest in the electrical signals generated by the heart and measured on the surface of the torso and may be diagnosable through alternative means of analysis, such as by determining cardiac activation times at a plurality of spatially distributed locations according to the techniques described herein.

FIGS. **4A** and **4B** are conceptual diagrams illustrating example systems for measuring body-surface potentials and, more particularly, torso-surface potentials. In one example illustrated in FIG. **4A**, sensing device **400A**, comprising a set of electrodes **404A-F** (generically “electrodes **404**”) and strap **408**, is wrapped around the torso of patient **1** such that the electrodes surround heart **10**. As illustrated in FIG. **4A**, electrodes **404** may be positioned around the circumference of patient **1**, including the posterior, lateral, and anterior surfaces of the torso of patient **1**. In other examples, electrodes **404** may be positioned on any one or more of the posterior, lateral, and anterior surfaces of the torso. Electrodes **404** may be electrically connected to processing unit **500** via wired connection **406**. Some configurations may use a wireless connection to transmit the signals sensed by electrodes **404** to processing unit **500**, e.g., as channels of data.

Although in the example of FIG. **4A** sensing device **400A** comprises strap **408**, in other examples any of a variety of mechanisms, e.g., tape or adhesives, may be employed to aid in the spacing and placement of electrodes **404**. In some examples, strap **408** may comprise an elastic band, strip of tape, or cloth. In some examples, electrodes **404** may be placed individually on the torso of patient **1**.

Electrodes **404** may surround heart **10** of patient **1** and record the electrical signals associated with the depolariza-

tion and repolarization of heart 10 after the signals have propagated through the torso of patient 1. Each of electrodes 404 may be used in a unipolar configuration to sense the torso-surface potentials that reflect the cardiac signals. Processing unit 500 may also be coupled to a return or indifferent electrode (not shown) which may be used in combination with each of electrodes 404 for unipolar sensing. In some examples, there may be 12 to 16 electrodes 404 spatially distributed around the torso of patient 1. Other configurations may have more or fewer electrodes 404.

Processing unit 500 may record and analyze the torso-surface potential signals sensed by electrodes 404. As described herein, processing unit 500 may be configured to provide an output to a user indicating the electrical dyssynchrony in heart 10 of patient 1. The user may make a diagnosis, prescribe CRT, position therapy devices, e.g., leads, or adjust or select treatment parameters based on the indicated electrical dyssynchrony.

In some examples, the analysis of the torso-surface potential signals by processing unit 500 may take into consideration the location of electrodes 404 on the surface of the torso of patient 1. In such examples, processing unit 500 may be communicatively coupled to an imaging system 501, which may provide an image that allows processing unit 500 to determine coordinate locations of each of electrodes 400 on the surface of patient 1. Electrodes 404 may be visible, or made transparent through the inclusion or removal of certain materials or elements, in the image provided by imaging system 501.

FIG. 4B illustrates an example configuration of a system that may be used to evaluate electrical dyssynchrony in heart 10 of patient 1. The system comprises a sensing device 400B, which may comprise vest 410 and electrodes 404 A-ZZ (generically "electrodes 404"), a processing unit 500, and imaging system 501. Processing unit 500 and imaging system 501 may perform substantially as described above with respect to FIG. 4A. As illustrated in FIG. 4B, electrodes 404 are distributed over the torso of patient 1, including the anterior, lateral, and posterior surfaces of the torso of patient 1.

Sensing device 400B may comprise a fabric vest 410 with electrodes 404 attached to the fabric. Sensing device 400B may maintain the position and spacing of electrodes 404 on the torso of patient 1. Sensing device 400B may be marked to assist in determining the location of electrodes 404 on the surface of the torso of patient 1. In some examples, there may be 150 to 256 electrodes 404 distributed around the torso of patient 1 using sensing device 400B, though other configurations may have more or fewer electrodes 404.

FIG. 5 is a block diagram illustrating an example system for measuring torso-surface potentials and providing indications of electrical dyssynchrony. The example system may comprise a processing unit 500 and a set of electrodes 404 on a sensing device 400, e.g., one of example sensing devices 400A or 400B (FIGS. 4A and 4B). The system may also include an imaging system 501.

As illustrated in FIG. 5, processing unit 500 may comprise a processor 502, signal processor 504, memory 506, display 508, and user input device 509. Processing unit 500 may also include an electrode location registration module 524. In the illustrated example, processor 502 comprises a number of modules and, more particularly, a projection module 514, an inverse problem module 516, an activation time module 518, an indices module 520, and an isochrones mapping module 522. Memory 506 may store recorded data 510 and models 512.

Processing unit 500 may comprise one or more computing devices, which may be co-located, or dispersed at various locations. The various modules of processing unit 500, e.g., processor 502, projection module 514, inverse problem module 516, activation time module 518, statistics module 520, isochrones mapping module 522, signal processor 504, electrode location registration module 524, display 508, memory 506, recorded data 510 and torso models 512 may be implemented in one or more computing devices, which may be co-located, or dispersed at various locations. Processor 502, and the modules of processor 502, may be implemented in one or more processors, e.g., microprocessors, of one or more computing devices, as software modules executed by the processor(s). Electrode location registration module 524 may, in some examples, be implemented in imaging system 501.

In addition to the various data described herein, memory 506 may comprise program instructions that, when executed by a programmable processor, e.g., processor 502, cause the processor and any components thereof to provide the functionality attributed to a processor and processing unit herein. Memory 506 may include any volatile, non-volatile, magnetic, optical, or electrical media, such as a hard disk, magnetic tape, random access memory (RAM), read-only memory (ROM), CD-ROM, non-volatile RAM (NVRAM), electrically-erasable programmable ROM (EEPROM), flash memory, or any other digital or analog media. Memory 506 may comprise one or more co-located or distributed memories. Memory 506 may comprise a tangible article that acts as a non-transitory storage medium for data and program instructions.

The torso-surface potential signals sensed by electrodes 404 of sensing device 400 may be received by signal processor 504 of processing unit 500. Signal processor 504 may include an analog-to-digital converter to digitize the torso-surface potential signals. Signal processor 504 may also include various other components to filter or otherwise condition the digital signals for receipt by processor 502.

Electrode location registration module 524 may receive imaging data from imaging system 501. Electrode location registration module 524 analyzes the imaging data. In particular, electrode registration location module 524 identifies electrodes 404, or elements co-located with the electrodes that are more clearly visible via the imaging modality, within the images. Electrode location registration module 524 may further identify the locations of each of the electrodes on the surface of the patient and/or within a three-dimensional coordinate system. In some examples, the locations of electrodes 404 may be manually identified and registered with processing unit 500, e.g., by a user, via electrode registration module 524.

The imaging data may comprise data representing one or more images of patient 1 wearing electrodes 404, e.g., of a sensing device 400. In some examples, the images may be obtained before or during a medical procedure, e.g., a surgical procedure to implant a cardiac rhythm device and lead system for delivery of CRT.

In some examples, processor 502 may store the torso-surface potential signals, imaging data from imaging system, electrode location data from electrode location registration module, or any values disclosed herein that are derived by processing of such signals and data by processor 502, within memory 506 as recorded data 510. Each recorded torso-surface potential signal, or other values derived therefrom, may be associated with a location of the electrode 404 that sensed the torso-surface potential signal. In this manner, the torso-surface potential data may be correlated with the

position of electrodes **404** on the torso of patient **1**, or within a three-dimensional coordinate system, enabling spatial mapping of the data to particular locations on the surface of the torso or within the coordinate system. In some examples, aspects of the techniques described herein may be performed at some time after the acquisition of the torso-surface potential signals and location data based on recorded data **510**.

Processor **502** may be configured to provide one or more indications of electrical dyssynchrony based on the torso-surface potential signals and, in some examples, the electrode location data. Example indications of electrical dyssynchrony include indices illustrating activation times for each electrode/location distributed about the torso or heart, or for one or more subsets of electrodes located within a common region, e.g., within a left posterior, left anterior, right posterior, or right anterior region. In some examples, processor **502** may be configured to provide a set of two or more different indications, e.g., several different indications, for each of two or more different regions, e.g., several different regions, of the torso or heart.

Some indications of dyssynchrony may include statistical values or other indices derived from activation times for each electrode location or one or more subsets of electrodes within one or more regions. Other examples indications of electrical dyssynchrony that may be determined based on activation times at various electrodes/locations include graphical indications, such as an isochrone or other activation maps, or an animation of electrical activation. Other examples indications of electrical dyssynchrony that may be determined based on activation times at various electrodes/locations include identifying one of a predetermined number of dyssynchrony levels, e.g., high, medium, or low, via text or color, e.g., red, yellow, green, for example.

In some examples, the various indications of dyssynchrony for one or more regions may be determined based on data collected at two or more different times and/or under two or more different conditions. For example, the various indications of dyssynchrony may be determined based on torso-potential signals collected during intrinsic conduction of heart **10**, and also determined based on torso-potential signals collected during CRT. In this manner, the potential dyssynchrony-reducing benefit of CRT may be evaluated for the patient by comparing the different values, graphical representations, or the like, resulting from intrinsic conduction and CRT. As another example, the various indications of dyssynchrony may be determined each of a plurality of different times based on torso-potential signals collected during delivery of CRT with different lead positions, electrode configurations, or CRT parameters, e.g., A-V or V-V interval values. In this manner, the relative dyssynchrony-reducing benefits of the different lead positions, electrode configurations, or CRT parameters positions may be evaluated for the patient by comparing the different values, graphical representations, or the like.

Models **512** may include a plurality of different models, e.g., three-dimensional models, of the human torso and heart. A model torso or model heart may be constructed by manual or semi-automatic image segmentation from available databases of previously acquired medical images (CT/MRI) of a plurality of subjects, e.g., cardiomyopathy patients, different than patient **1**, using commercially available software. Each model may be discretized using a boundary element method. A plurality of different torso models may be generated. The different models may represent different subject characteristics, such as different genders, disease states, physical characteristics (e.g., large

frame, medium frame and small frame), and heart sizes (e.g., x-large, large, medium, small). By providing input via user input **509**, a user may select from among the various model torsos and model hearts that may be stored as models **512** in memory **506**, so that the user may more closely match the actual torso and heart **10** of patient **1** with the dimensions and geometry of a model torso and model heart. In some examples, medical images of the patient, e.g., CT or MRI images, may be manually or semi-automatically segmented, registered, and compared to models **512** for selection from amongst the models **512**. Furthermore, single or multiple view 2-D medical images (e.g., x-ray, fluoroscopy) may be segmented or measured to determine approximate heart and torso dimensions specific to the patient in order to select the best fit model torso and heart.

Projection module **514** may project the locations of electrodes **404**, e.g., stored as recorded data **510** within of memory **506**, onto an appropriate, e.g., user-selected, model torso contained in model data module **512** of memory **506**. By projecting the location of electrodes **404** onto the model torso, projection module **514** may also project the torso-surface potential signals of patient **1** sensed by electrodes **404** onto the model torso. In other examples, the measured electrical potentials may be interpolated and resampled at electrode positions given by the model. In some examples, projecting the torso-surface potentials onto the model torso may allow processor **502**, via inverse problem module **516**, to estimate the electrical activity of at various locations or regions of the model heart corresponding to heart **10** of patient **1** that produced the measured torso-surface potentials.

Inverse problem module **516** may be configured to solve the inverse problem of electrocardiography based on the projection of the measured torso-surface potentials, recorded by electrodes **404**, onto the model torso. Solving the inverse problem of electrocardiography may involve the estimation of potentials or activation times in heart **10** based on a relationship between the torso and heart potentials. In one example method, model epicardial potentials are computed from model torso potentials assuming a source-less volume conductor between the model heart and the model torso in an inverse Cauchy problem for Laplace's equation. In another example method, an analytic relationship between torso-surface potentials and the cardiac transmembrane potential is assumed. Torso-surface potentials may be simulated based on this relationship. In some examples, inverse problem module **516** may utilize techniques described by Ghosh et al. in "Accuracy of Quadratic Versus Linear Interpolation in Non-Invasive Electrocardiographic Imaging (ECGI)," *Annals of Biomedical Engineering*, Vol. 33, No. 9, September 2005, or in "Application of the L1-Norm Regularization to Epicardial Potential Solution of the Inverse Electrocardiography Problem," *Annals of Biomedical Engineering*, Vol. 37, No. 5, 2009, both of which are incorporated herein by reference in their entireties. In other examples, any known techniques for solving the inverse problem of electrocardiography may be employed by inverse problem module **516**.

Activation time module **518** may compute the activation times directly from measured torso-surface potentials, or by estimating model transmembrane potentials. In either case, an activation time for each electrode/location may be determined as a time period between two events, such as between the QRS complex onset and the minimum derivative (or steepest negative slope) of the sensed torso potential signal or estimate epicardial potential signal. Thus, in one example, cardiac activation times are estimated from the steepest negative slope of the model epicardial electrograms. Cardiac

activation times (parameters in the analytic relationship between torso-surface potential and cardiac transmembrane potential) may, in other configurations, be computed based on minimizing the least square difference between the measured torso-surface potentials and simulated torso-surface potentials. A color-coded isochrone map of ventricular, epicardial, or torso-surface activation times may be shown by display 308. In other examples, display 308 may show a two-color animation of propagation of the activation wavefront across the surface of the model heart or the torso-surface.

Indices module 520 may be configured to compute one or more indices of electrical dyssynchrony from the torso-surface or cardiac activation times. These indices may aid in the determination of whether the patient is a candidate for CRT, placement of CRT leads, and selection of CRT parameters. For example, LV lead 102 (FIG. 1) may be positioned at the site that reduces dyssynchrony from one or more indices or, alternatively, the largest electrical resynchronization as demonstrated by the indices. The same indices may be also used for programming A-V and/or V-V delays during follow-up. As indicated above, the indices may be determined based on the activation times for all electrodes/locations, or for one or more subsets of electrodes in one or more regions, e.g., to facilitate comparison or isolation of a region, such as the posterior and/or left anterior, or left ventricular region.

One of the indices of electrical dyssynchrony may be a standard deviation index computed as the standard deviation of the activations-times (SDAT) of some or all of electrodes 404 on the surface of the torso of patient 1. In some examples, the SDAT may be calculated using the estimated cardiac activation times over the surface of a model heart.

A second example index of electrical dyssynchrony is a range of activation times (RAT) which may be computed as the difference between the maximum and the minimum torso-surface or cardiac activation times, e.g., overall, or for a region. The RAT reflects the span of activation times while the SDAT gives an estimate of the dispersion of the activation times from a mean. The SDAT also provides an estimate of the heterogeneity of the activation times, because if activation times are spatially heterogeneous, the individual activation times will be further away from the mean activation time, indicating that one or more regions of heart 10 have been delayed in activation. In some examples, the RAT may be calculated using the estimated cardiac activation times over the surface of a model heart.

A third example index of electrical dyssynchrony estimates the percentage of electrodes 404 located within a particular region of interest for the torso or heart, whose associated activation times are greater than a certain percentile, for example the 70th percentile, of measured QRS complex duration or the determined activation times for electrodes 404. The region of interest may be a posterior, left anterior, and/or left-ventricular region, as examples. This index, the percentage of late activation (PLAT), provides an estimate of percentage of the region of interest, e.g., posterior and left-anterior area associated with the left ventricular area of heart 10, which activates late. A large value for PLAT may imply delayed activation of substantial portion of the region, e.g., the left ventricle 12 (FIG. 1), and the potential benefit of electrical resynchronization through CRT by pre-exciting the late region, e.g., of left ventricle 12. In other examples, the PLAT may be determined for other subsets of electrodes in other regions, such as a right anterior region to evaluate delayed activation in the right ventricle. Furthermore, in some examples, the PLAT may be calculated using

the estimated cardiac activation times over the surface of a model heart for either the whole heart or for a particular region, e.g., left or right ventricle, of the heart.

Isochrone mapping module 522 may be configured to generate an isochrone map depicting the dispersion of activation times over the surface of the torso of patient 1 or a model heart. Isochrone mapping module 522 may incorporate changes in the torso-surface or cardiac activation times in near real-time, which may permit near instant feedback as a user adjusts a CRT device or monitors patient 1 to determine if CRT is appropriate. Isochrone maps generated by isochrone mapping module 522 may be presented to the user via display 508.

In general, processor 502 may generate a variety of images or signals for display to a user via display 508 based on the measured torso-surface potentials, calculated torso-surface or estimated cardiac activation times, or the degree of change in electrical dyssynchrony. For example, a graded response reflecting the efficacy of a particular location of the LV lead 102 during biventricular pacing or single ventricle fusion pacing may be provided to the physician in terms of a red, yellow and green signal. A red signal may be shown if the reduction in electrical dyssynchrony during CRT pacing compared to intrinsic rhythm is negative (an increase in electrical dyssynchrony) or minimal, e.g., less than 5%. A yellow signal may be triggered if there is some reduction in electrical dyssynchrony during CRT pacing compared to intrinsic rhythm, for example between 5% and 15%, but there may be potentially better sites for lead placement. If the reduction in electrical dyssynchrony during CRT pacing compared to intrinsic rhythm is substantial, e.g., greater than 15%, a green signal may be triggered indicating to the physician that the present site provides effective changes in synchronization. The feedback from this system in combination with other criteria (like magnitude of pacing threshold, impedance, battery life, phrenic nerve stimulation) may be also used to choose an optimal pacing vector for one or more multipolar leads. The feedback from this system may be also used for selecting optimal device timings (A-V delay, V-V delay, etc) influencing the extent of fusion of intrinsic activation with paced activation from single or multiple ventricular sites, or discerning acute benefit of single site fusion pacing versus multi-site pacing and choice of appropriate pacing type.

Display 508 may also display three-dimensional maps of electrical activity over the surface of the torso of patient 1 or over a model heart. These maps may be isochrone maps showing regions of synchronous electrical activity as the depolarization progresses through heart 10 of patient 1. Such information may be useful to a practitioner in diagnosing asynchronous electrical activity and developing an appropriate treatment, as well as evaluating the effectiveness of the treatment.

FIG. 6 is a series of simulated isochrone maps 600 of torso-surface activation times over the torso of a patient suffering from an electrical dyssynchrony in the left ventricle before and during treatment with a CRT device. The isochrone maps before (intrinsic) and after treatment are divided into two views: anterior and posterior. Line 602 represents the location of a subset of electrodes 404, e.g., a subset of electrodes 404 of sensing device 400B, that may be used to calculate one or more indices of electrical dyssynchrony. In some examples, line 602 may represent electrodes 404 on sensing device 400A.

The isochrone maps 600 of the natural and CRT assisted torso-surface activation times may be generated using multiple electrodes 404 distributed over the surface of the torso

of a patient, e.g., using sensing device 400B. Generation of the isochrone maps 600 may include determining the location of electrodes 404, and sensing torso-surface potential signals with the electrodes. Generation of the isochrone maps 600 may further include calculating the torso-surface activation time for each electrode or electrode location by determining the point in the recorded QRS complex of the signal sensed by the electrodes corresponding to the maximum negative slope. In other examples, the torso-surface activation times may be determined by identifying the minimum derivative of the QRS complex. The measured torso-surface activation times may then be standardized and an isochrone map of the surface of the torso of the patient generated.

The delayed activation of certain locations associated with certain ones of electrodes 404 due to the electrical dyssynchrony is apparent in the posterior views of the intrinsic torso-surface activation times. For example, some regions of isochrone maps 600 indicate increased delay in the activation of the underlying heart. A corresponding posterior view during treatment with a CRT device indicates that regions 606, the same location as the regions indicating increased delay in the activation of the underlying heart on the maps of intrinsic torso-surface activation times, exhibit increased synchrony in electrical ventricular activity. The CRT maps exhibit decreased range and a lower standard deviation of torso-surface activation times. Further, the posterior regions no longer exhibit delayed activation times. The isochrone map of the torso-surface activation times during intrinsic and CRT pacing and changes in distribution of activation-times from intrinsic to CRT pacing may be used for diagnostic purposes or the adjustment of a CRT device.

One or more indices of electrical dyssynchrony may also be calculated from the torso-surface activation times used to generate isochrone maps 600. For example, SDAT, an indication of the spread of the activation times, for the patient's intrinsic heart rhythm using the complete set of electrodes 404 is 64. Using the reduced lead set marked by line 602 results in an SDAT of 62. The RAT for the intrinsic heart rhythm and complete lead set is 166.5 while the reduced lead set has a RAT of 160. PLAT for the intrinsic heart rhythm using the reduced and complete lead sets are 56.15% and 66.67%, respectively. This indicates that using a reduced lead set that circumscribes the heart of the patient, e.g., sensing device 400A and associated electrodes 404, may provide comparable indices of electrical dyssynchrony compared to using an electrode set covering the torso of the patient, such as sensing device 400B.

The indices of electrical dyssynchrony also provide indication of the effectiveness of the CRT device, with the SDAT for the reduced set of electrodes declining to 24, the RAT to 70 and PLAT to 36%. This indicates that the torso-surface activation times during CRT treatment were more narrowly distributed and in a smaller range than in the normal heart rhythm and that the percentage of electrodes 404 located on the left anterior surface of the torso of the patient registering late activation times decreased markedly.

FIG. 7 is a flow diagram illustrating an example operation of a system to evaluate the cardiac electrical dyssynchrony of a patient via the torso-surface activation times. The location of electrodes, e.g., electrodes 404 (FIGS. 4A and 4B), distributed over the surface of the torso of the patient may be determined (700). A cardiac event, e.g., a depolarization, may generate an electrical signal that propagates through the torso of a patient, e.g., patient 1 (FIG. 1) and registers on the electrodes. The signal sensed by the elec-

trodes may be received (702), e.g., by processing unit 500 (FIG. 5). The processing unit may calculate the torso-surface activation times (704). In some examples, the processing unit may also construct a torso-surface activation times isochrone map (706). The processing unit may also calculate at least one index of cardiac electrical dyssynchrony (708). These indices may comprise one or more of the SDAT (710), RAT (712), and the PLAT (714).

A cardiac event, such as a depolarization, generates an electrical signal that propagates through the torso. The electrical signal may comprise a QRS complex, or a variant caused by a heart related condition such as a left or right bundle branch block. The electrical signal may not propagate uniformly through the torso of a patient due to variations in conductivity within the torso and the heart. These delays may manifest in electrodes distributed over the surface of the torso of the patient registering the same electrical signal at different points in time.

The electrical signal generated by the cardiac event may register on the plurality of electrodes distributed over the surface of the torso of patient. The electrodes may be distributed over the anterior, lateral, and/or posterior surfaces of the torso, allowing the generation of a three-dimensional picture of the electrical activity occurring within the torso. In some examples, the electrodes may be placed to provide extensive coverage both above and below the heart, e.g., by using sensing device 400B (FIG. 4B). In other examples, a reduced set of electrodes may be arranged around the circumference of the torso, circumscribing the heart of the patient, e.g., using sensing device 400A (FIG. 4A). The electrodes may receive the complete waveform of the electrical signal generated by the cardiac event, and transmit the signal to a processing unit.

The location of electrodes distributed over the surface of the torso of the patient may be determined (700). Locating the electrodes may be performed automatically, e.g. by imaging system 501 and electrode location registration module 524 of processing unit 500 (FIG. 5). The electrodes may be located by analyzing one or more images of the torso of a patient and performing a pattern matching routine, e.g., recognizing the shape of an electrode against the torso of the patient, and storing the location of the electrode on the torso of the patient in processing unit memory. In other examples, the location of sensing device 400A or 400B may be determined and the locations of the electrodes determined based on the position of the sensing device, e.g., basing the position of the electrode on the patient through the known position of the electrode on the sensing device. In another example, the position of the electrodes may be measured manually.

The processing unit may receive the electrical signal from the electrodes and record the output in memory (702). The processing unit may record the raw output, e.g., the raw ECG tracing from each electrode, as well as location data for the electrodes, allowing the electrical signals detected by the electrodes to be mapped onto the surface of the torso of the patient.

The processing unit may compute the torso-surface activation times (704). A processor, e.g., processor 502 of processing unit 500 (FIG. 5), may retrieve ECG tracing data stored within the processing unit memory and analyze the tracing to detect depolarization of the ventricles of the heart, typically marked by a QRS complex in the tracing. The processor may, in some examples, detect ventricular depolarization by determining the time of the minimum derivative (or steepest negative slope) within the QRS complex measured with respect to the time of QRS complex onset.

The determination of the activation time may be made for each electrode and stored in the processing unit memory.

In some configurations, the processing unit may construct an isochrone map of the torso-surface activation times, allowing the user to visually inspect the propagation of the electrical signals of the heart after progression through the torso of the patient. The isochrone map may be constructed by dividing the range of measured torso-surface activation times into a series of sub-ranges. The location of each electrode on the surface of the torso of the patient may be graphically represented. Regions of electrodes whose measured activation times fall within the same sub-range may be represented by the same color on the graphical representation.

The processing unit may also calculate one or more indices of electrical dyssynchrony based on the torso-surface activation times (708). These indices may include the SDAT (710), RAT (712), and PLAT (714). In some examples, the PLAT may be determined as the percentage of posterior electrodes activating after a certain percentage of the QRS complex duration.

As discussed above, in some examples, the construction of a torso-surface activation times isochrone map (706), or other graphical representation of dyssynchrony, as well as the calculation of indices of electrical dyssynchrony (708), may be performed for a particular region of the torso based on the signals received from electrodes (702) in such regions. Graphical representations and indices of electrical dyssynchrony may be determined for each of a plurality of regions based on the signals received from the electrodes for such regions. In some examples, the representations and indices for various regions may be presented together or compared.

FIG. 8 is a flow diagram illustrating an example technique for measuring the cardiac electrical dyssynchrony of a patient via measured torso-surface activation times. A processing unit 500 may receive torso-surface potential signals from a plurality of electrodes (800), e.g., electrodes 404 (FIGS. 4A and 4B). The processing unit 500 may calculate the torso-surface activation times for each of the plurality of electrodes (802). The processing unit 500 may provide at least one indication of cardiac electrical dyssynchrony (804).

A user may evaluate the whether a patient is a candidate for CRT based on the at least one indication of electrical dyssynchrony (806). The user may also monitor the at least one indication of electrical dyssynchrony (808), and use the changes in the at least one indication to aid in adjusting the positioning of electrodes, e.g., electrodes 108, 110, and 112 (FIG. 1), during implantation of a CRT device (810), e.g., IMD 100 (FIG. 1), or selection of the various programmable parameters, such as electrode combination and the A-V or V-V pacing intervals, of the CRT device (812), during implantation or a follow-up visit.

The various indications of cardiac electrical dyssynchrony described herein, such as statistical or other indices, or graphical representations of activation times, may indicate the presence of damage to electrical conductivity of the heart of the patient, for example the presence of a left or right bundle branch block, that may not be apparent from the examination of a standard 12-lead ECG readout. For example, a large SDAT indicates that the activation of the ventricles is occurring over a large time span, indicating that the depolarization of the ventricles is not occurring simultaneously. A large RAT also indicates a broad range of activation times and asynchronous contraction of the ventricles. A high PLAT indicates that a specific region of the heart, e.g., the posterior regions associated with the left

ventricle, may be failing to activate in concert with the measured QRS complex. Additionally, by monitoring the at least one indication of cardiac electrical dyssynchrony, the user may detect changes in the electrical activity of the heart caused by different treatments or treatment configurations.

As described above, the various indications of electrical dyssynchrony, such as statistical indexes, may be calculated for each of a plurality of regions, e.g., posterior, left anterior, or the like, based on torso-surface activation times from the region. Additionally, evaluating whether a patient is a candidate for CRT based on the at least one indication of electrical dyssynchrony (806) may include determining the one or more indications of electrical dyssynchrony based on torso-surface activation times both during intrinsic conduction of the heart, and during CRT. Differences between the indications during intrinsic conduction and CRT may indicate that CRT would provide benefit for the patient, e.g., that the patient is a candidate for CRT. As described above, the user may also evaluate whether a patient is a candidate for CRT based on at least one indication of electrical dyssynchrony based on intrinsic rhythm alone. Furthermore, monitoring the at least one indication of electrical dyssynchrony (808) during implantation or a follow-up visit may include determining the one or more indications of electrical dyssynchrony for each of a plurality of lead positions, electrode configurations, or other parameter values based on torso-surface activation times resulting from delivery of CRT at the positions, or with the electrode configurations or parameter values. In this manner, differences between dyssynchrony indications associated with various locations, electrode configurations, or parameter values may be compared to determine preferred locations, configurations, or values.

FIG. 9 is a series of isochrone maps of cardiac activation times. Views 900, 902 and 904 were constructed using torso-surface potentials measured on the surface of the torso of a patient and projected onto three dimensional models of the torso and the heart of the patient. Views 910, 912, and 914 were constructed using the measured torso-surface potentials of the same patient projected onto a different model torso and model heart.

The three-dimensional representation of the hearts depicted in views 900, 902, 904, 910, 912 and 914 were constructed using computer tomography (CT) images of hearts obtained from databases of previously acquired cardiothoracic images. The locations of the electrodes, e.g., electrodes 404 of sensing device 400B (FIG. 4B), on the torso of the patient may be plotted to approximate locations on a model torso. A computer may be used to solve the inverse problem of electrocardiography, which includes determining the electrical activity on the surface of the heart that would produce the measured torso-surface potentials. The isochrone maps illustrated in views 900, 902, 904, 910, 912 and 914 are based on images of hearts of two different patients, which are also used to determine the geometry of the heart and relationship to the corresponding torso for solving the inverse problem of electrocardiography.

The model torsos and hearts may be constructed by manual or semi-automatic image segmentation from available databases of previously acquired medical images (CT/MRI) of cardiomyopathy patients using commercially available software. Each model may be discretized using boundary element method and may be further manipulated to account for patients with different physical characteristics (e.g., large frame, medium frame and small frame) and heart sizes (e.g., x-large, large, medium, small).

A user may select the appropriate model torso and heart to suit the patient, e.g., a patient having a large torso may be

simulated with a large frame model torso. In some examples, medical images of the patient, e.g., CT or MRI images, may be manually or semi-automatically segmented, registered, and compared to a variety of available models for selection from amongst the models. One or more views of 2-D 5 medical images (e.g., X-ray or fluoroscopy) may also be used. The user may project the measured torso-surface potentials from the torso of the patient onto the corresponding locations on the model torso. The inverse problem of propagating the electrical signals from the model torso to the model heart may then be solved, and activation times for the model heart may be estimated.

In one example in which the techniques of this disclosure were applied, human thoracic CT images for other subjects were obtained from image databases. Semi-automatic image segmentation was performed on the images to generate the three-dimensional representation of the different models of hearts and torsos. In some examples, image segmentation may be done with the AMIRA software package commercially-available from Visage Imaging, Inc., of San Diego, Calif. 20

For the example, the projection of electrode locations on the patient torso to the model torso was approximate. In particular, the locations of the electrodes on the patient torso were projected onto the surface of the model torso based on the order in which the electrodes were mounted on the patient. For the purpose of this projection, the patient and model torsos were divided into right anterior, left anterior, right posterior and left posterior regions, using the sternum (anterior) and the spine (posterior) as references. Electrodes were arranged in vertical strips and three strips were applied to each region of the torso. Electrodes in these regions were projected on to the corresponding segments of the model torso. The method described is one of many techniques that may be used to register or map the geometrical distribution of measured electrical potentials. For example, the measured electrical potentials may be interpolated and resampled at electrode positions given by the model. Projection of the electrode locations from segments of the patient torso onto the corresponding segments of the model torso in the correct order enabled the activation patterns and spatial dispersion of activation on the model heart to reflect the activation patterns and spatial dispersion of activation on the actual patient heart with relative accuracy. In one example, the inverse problem of electrocardiography may be solved using the Matlab regularization toolbox (Hansen PC, Regularization Tools: A Matlab package for analysis and solution of discrete ill-posed problems, Numerical Algorithms, 6(1994), pp 1-35). 45

Input data-sets for solving the inverse problem consistent with the example may include multi-electrode surface ECG measurements, the 3-D Cartesian coordinates of the model heart and torso surfaces, and the mesh over each model surface which specified the connectivity of the different points on each surface. An output consistent with the techniques of this disclosure may include activation times on the 3-D model heart surface which can be visualized using visualization software and computer graphics tools. In some examples, the 3-D model heart surface may be visualized using the tools in Matlab (Mathworks Inc, Natick, Mass.) or more advanced visualization software, such as Tecplot (Tecplot Inc, Bellevue, Wash.). 55

Comparing estimated cardiac activation times on two different, both cardiac activation times determined from the same torso-surface potential signals for one subject, show similar patterns and distribution. For example, a region **906** of views **902** and **904** corresponds in size and activation time 65

to a region views **912** and **914**. A region of views **902** and **904** corresponds to a region of views **912** and **914**. Additionally, the standard deviations of activations time for both models are both derived from the same torso-surface potentials for one subject, were similar (17.6 and 15.5 ms). The overall pattern of cardiac activation and measures of dispersion of cardiac activation times are thus not dependent on a specific heart-torso model. Using a generic heart-torso model may allow a user to create an isochrone model of the cardiac activation time suitable for diagnosis and observation while avoiding expense, inconvenience, and radiation exposure that may be caused by the CT scan or other imaging that may be used to produce a patient-specific model of the heart of the patient.

FIG. **10** is a flow diagram illustrating an example operation of a system to measure the cardiac electrical dyssynchrony of a patient via the cardiac activation times. Processing unit **500** determines the location of the electrodes **404**, e.g., based on an analysis of imaging data by an electrode location registration module **524**. Processing unit projects the locations of the electrodes onto a model torso, e.g., a selected model torso (**1002**). 30

A cardiac event, e.g., depolarization, occurs causing an electrical signal to propagate through the torso of the patient, and register on the electrodes distributed on the surface of the torso of the patient. The torso-surface potential signals sensed by the electrodes may be received by processing unit **500** (**1004**). The processing unit may project the signals onto the surface of the model torso based on the determined locations of the electrodes (**1006**). 35

The processing unit may solve the inverse problem of determining epicardial potentials based on torso-surface potentials (**1008**). The processing unit may then calculate cardiac activation times at a variety of locations of the model heart based upon the projected torso-surface potentials (**1010**). The cardiac activation times may be computed by, for example, determining the greatest negative slope of the epicardial electrogram potentials (**1016**) or by least squares minimization in the solution of the inverse problem (**1018**). The cardiac activation time may be displayed (**1012**). Examples of potential methods for displaying cardiac activation times include isochrone maps (**1014**) and a movie depicting the progression of the wavefront over the model heart (**1016**). The processing unit may be configured to allow a user select between, or display simultaneously, various display modes, including the wave front movie and isochrone maps. Additionally, one or more indices of cardiac electrical dyssynchrony may be calculated (**1018**), including the SDAT (**1020**), RAT (**1022**), and PLAT (**1024**). 40

For solving the inverse problem (**1008**), epicardial potentials may be computed from projected torso-surface potentials assuming a source-less volume conductor between the heart and the torso in an inverse Cauchy problem for Laplace's equation. Alternatively, an analytic relation between torso-surface potentials and the cardiac transmembrane potential may be assumed. Additionally, cardiac activation times may be estimated (**1010**) from the steepest negative slope of the epicardial electrograms determined from the inverse solution of the torso-surface potential/epicardial potential transformation. In other examples, model torso-surface potentials may be simulated based on the analytic relationship approach to determining the cardiac transmembrane potential from torso-surface potential. Cardiac activation times (parameters in the analytic relationship) may be computed based on minimizing the least square difference between the projected model torso-surface potentials and simulated torso-surface potentials. 45

In some examples, the construction of a torso-surface activation times isochrone map (1014), wavefront animation (1016), or other graphical representation of cardiac electrical dyssynchrony, as well as the calculation of indices of cardiac electrical dyssynchrony (1018), may be performed for a particular region of the model heart based the computed cardiac activation times in such regions. Graphical representations and indices of cardiac electrical dyssynchrony may be determined for each of a plurality of regions based on the computed cardiac activation times in such regions. In some examples, the representations and indices for various regions may be presented together or compared.

FIG. 11 is a flow diagram illustrating an example technique for measuring the cardiac electrical dyssynchrony of a patient via determined cardiac activation times. The techniques may comprise determining the location of a plurality of electrodes (1100), projecting the location of the electrodes onto the surface of a model torso (1102), recording the output of the plurality of electrodes (1104), projecting the output of the plurality of the electrodes on the surface of the model torso (1106), solving the inverse problem (1108) and determining the cardiac activation times for a model heart from the projected torso-surface potentials (1110). The cardiac activation times may be displayed (1112). One or more indices of electrical dyssynchrony may be calculated (1114). The output, the indices of cardiac electrical dyssynchrony and cardiac activation time maps, may be monitored, allowing a user to diagnose the patient, adjust the position of CRT electrodes during implantation (1118), or adjust A-V or V-V pacing intervals of the CRT device (1120).

A user may monitor the output of the calculations (1116), e.g., the at least one indices of cardiac electrical dyssynchrony or the display of cardiac activation times. Monitoring these values may allow the user to diagnose a condition that might benefit from CRT or to evaluate the effectiveness of CRT. For example, the at least one index of cardiac electrical dyssynchrony may indicate the presence of damage to electrical conductivity of the heart of the patient, for example the presence of a left or right bundle branch block, that may not be apparent from the examination of a standard 12 lead ECG readout. A large SDAT indicates that the activation of the ventricles is occurring over a large time span, indicating that the depolarization of the ventricles is not occurring simultaneously. A large RAT also indicates a broad range of activation times and asynchronous contraction of the ventricles. A high PLAT may indicate that a specific region of the heart, e.g., the posterior regions more associated with the left ventricle, is failing to activate in concert with the measured QRS complex.

The user may adjust the positioning of CRT electrodes, e.g., electrodes 108, 110, and 112 of IMD 100 (FIG. 1) according to the displayed cardiac activation times or the indices of cardiac electrical dyssynchrony. For example, the processing unit, via a display, may implement system that displays shifting colors based on the percentage change of the indices of cardiac electrical dyssynchrony. As the position of the CRT electrodes are adjusted (1118), the displayed colors may shift from red to yellow to green based on the percentage improvement of the indices of cardiac electrical dyssynchrony. This may allow a user to rapidly determine if the adjustments of the CRT electrodes are having a positive effect on the symptoms of the patient. In another example, the user may adjust the A-V or V-V pacing intervals of an implanted CRT device (118). The minimum value of the indices of cardiac electrical dyssynchrony may indicate adequate pacing intervals. Isochrone maps or wave front

propagation movies may also be used to aid in CRT adjustments or to diagnose conditions that may be responsive to CRT treatment.

As indicated above, to facilitate evaluating the whether a patient is a candidate for CRT based on the monitored output (1116), the one or more indications of cardiac electrical dyssynchrony, e.g., indices or graphical indications, may be determined based on torso-surface activation times during both intrinsic conduction of the heart, and during CRT. Differences between the indications during intrinsic conduction and CRT may indicate that CRT would provide benefit for the patient, e.g., that the patient is a candidate for CRT. Furthermore, during implantation or a follow-up visit, the one or more indications of cardiac electrical dyssynchrony may be determined for each of a plurality of lead positions, electrode configurations, or other parameter values based on torso-surface activation times resulting from delivery of CRT at the positions, or with the electrode configurations or parameter values. In this manner, differences between cardiac electrical dyssynchrony indications associated with various locations, electrode configurations, or parameter values may be compared to determine preferred locations, configurations, or values.

Various examples of this disclosure have been described. However, one of ordinary skill in the art will appreciate that various modifications may be made to the described embodiments without departing from the scope of the claims. For example, although SDAT, RAT and PLAT have been discussed as example statistical indices of the dispersion of activation times, other indices or metrics of the dispersion of the timing of depolarization may be determined according to the techniques of this disclosure. As one example, a range of activation times between two specific regions, e.g., anterior and posterior, may be determined. As another example, a range or variability of activation times after excluding certain locations or regions may be determined according to the techniques of this disclosure. The excluded locations or regions may be those that are believed to be scar tissue, e.g., identified by low amplitude electrical signals, or locations or regions that are beyond the extent of the far-field QRS complex. In general, calculation of an index may include determining any statistical or other value based on the torso-surface or cardiac activation times, or some subset thereof. These and other examples are within the scope of the following claims.

The invention claimed is:

1. A system comprising a plurality of electrodes; and a processing unit configured to:

- receive a torso-surface potential signal sensed by each electrode of the plurality of electrodes while the electrodes are distributed on a torso of a patient,
- project each of the torso-surface potential signals onto a respective location on a surface of a model torso based on locations of the electrodes on the torso of the patient,
- determine a set of cardiac activation times for a model heart within the model torso based on the projected torso-surface potential signals and a location of the model heart within the model torso, and
- determine a parameter of cardiac resynchronization therapy (CRT) for the patient based on the set of cardiac activation times.

2. The system of claim 1, wherein the processing unit is configured to determine the parameter of CRT by at least selecting one or more electrodes with which a medical device delivers the CRT to the patient.

3. The system of claim 1, wherein the processing unit is configured to determine the parameter of CRT by at least selecting a position of a medical lead within a heart of the patient based on the set of cardiac activation times.

4. The system of claim 1, wherein the parameter of CRT comprises a pacing vector for the CRT.

5. The system of claim 1, wherein the parameter of CRT comprises a timing parameter with which a medical device delivers the CRT to the patient.

6. The system of claim 5, wherein the timing parameter comprises at least one of an atrio-ventricular (A-V) delay or an intra-ventricular (V-V) delay for the CRT.

7. The system of claim 1, wherein the parameter of CRT comprises a pacing threshold with which a medical device delivers the CRT to the patient.

8. The system of claim 1, wherein the processing unit is configured to determine the parameter of CRT by at least selecting one or more tissue sites within the patient for the delivery of the CRT by a medical device.

9. The system of claim 1, wherein the processing unit is further configured to:

receive an updated torso-surface potential signal sensed by each of the plurality of electrodes distributed on the torso of the patient during delivery of the CRT to the patient by a medical device;

project each of the updated torso-surface potential signals onto a respective location on the surface of the model torso based on locations of the electrodes on the torso of the patient; and

determine an updated set of cardiac activation times for the model heart within the model torso based on the projected updated torso-surface potential signals and the location of the model heart within the model torso.

10. The system of claim 9, wherein the updated torso-surface potential signals comprise at least one torso-surface potential signal sensed by an electrode during delivery of the CRT to the patient by the medical device via an endocardial lead.

11. A method comprising:

receiving, by a processing unit, a torso-surface potential signal sensed by each electrode of a plurality of electrodes while the electrodes are distributed on a torso of a patient;

projecting, by the processing unit, each of the torso-surface potential signals onto a respective location on a surface of a model torso based on locations of the electrodes on the torso of the patient;

determining, by the processing unit, a set of cardiac activation times for a model heart within the model torso based on the projected torso-surface potential signals and a location of the model heart within the model torso; and

determining, by the processing unit, a parameter of cardiac resynchronization therapy (CRT) for the patient based on the set of cardiac activation times.

12. The method of claim 11, wherein determining, by the processing unit, the parameter of CRT comprises selecting one or more electrodes with which a medical device delivers the CRT to the patient.

13. The method of claim 11, wherein determining, by the processing unit, the parameter of CRT comprises selecting a position of a medical lead within a heart of the patient based on the set of cardiac activation times.

14. The method of claim 11, wherein the parameter of CRT comprises a pacing vector for the CRT.

15. The method of claim 11, wherein the parameter of CRT comprises a timing parameter with which a medical device delivers the CRT to the patient.

16. The method of claim 15, wherein the timing comprises at least one of an atrio-ventricular (A-V) delay or an intra-ventricular (V-V) delay for the CRT.

17. The method of claim 11, wherein the parameter of CRT comprises a pacing threshold with which a medical device delivers the CRT to the patient.

18. The method of claim 11, wherein determining, by the processing unit, the parameter of CRT comprises selecting one or more tissue sites within the patient for the delivery of the CRT by a medical device.

19. The method of claim 11, further comprising:

receiving, by the processing unit, an updated torso-surface potential signal sensed by each of the plurality of electrodes distributed on the torso of the patient during delivery of the CRT to the patient by a medical device; projecting, by the processing unit, each of the updated torso-surface potential signals onto a respective location on the surface of the model torso based on locations of the electrodes on the torso of the patient; and determining, by the processing unit, an updated set of cardiac activation times for the model heart within the model torso based on the projected updated torso-surface potential signals and the location of the model heart within the model torso.

20. The method of claim 19, wherein the updated torso-surface potential signals comprise at least one torso-surface potential signal sensed by an electrode during delivery of the CRT to the patient by the medical device via an endocardial lead.

21. A system comprising:

means for receiving a torso-surface potential signal sensed by each electrode of a plurality of electrodes while the electrodes are distributed on a torso of a patient;

means for projecting each of the torso-surface potential signals onto a respective location on a surface of a model torso based on locations of the electrodes on the torso of the patient;

means for determining a set of cardiac activation times for a model heart within the model torso based on the projected torso-surface potential signals and a location of the model heart within the model torso; and

means for determining a parameter of cardiac resynchronization therapy (CRT) for the patient based on the set of cardiac activation times.

22. The system of claim 21, wherein the parameter of CRT comprises one or more of: one or more electrodes with which a medical device delivers the CRT pacing to the patient, a position of a medical lead within a heart of the patient, a pacing vector for the CRT, a timing parameter with which the medical device delivers the CRT to the patient, a pacing threshold with which the medical device delivers the CRT to the patient, or comprises one or more tissue sites within the patient for the delivery of the CRT by the medical device.

23. A non-transitory computer-readable storage medium comprising instructions that, when executed by a processing unit, cause the processing unit to:

receive a torso-surface potential signal sensed by each electrode of the plurality of electrodes while the electrodes are distributed on a torso of a patient,

project each of the torso-surface potential signals onto a respective location on a surface of a model torso based on locations of the electrodes on the torso of the patient,

23

determine a set of cardiac activation times for a model heart within the model torso based on the projected torso-surface potential signals and a location of the model heart within the model torso, and
determine a parameter of cardiac resynchronization therapy (CRT) delivered to the patient based on the set of cardiac activation times.

24. The non-transitory computer-readable storage medium of claim **23**, wherein the parameter of CRT comprises one or more of: one or more electrodes with which a medical device delivers the CRT pacing to the patient, a position of a medical lead within a heart of the patient, a pacing vector for the CRT, a timing parameter with which the medical device delivers the CRT to the patient, a pacing threshold with which the medical device delivers the CRT to the patient, or comprises one or more tissue sites within the patient for the delivery of the CRT by the medical device.

* * * * *

24

专利名称(译)	评估心脏内激活模式		
公开(公告)号	US9974457	公开(公告)日	2018-05-22
申请号	US14/635498	申请日	2015-03-02
[标]申请(专利权)人(译)	美敦力公司		
申请(专利权)人(译)	美敦力公司, INC.		
当前申请(专利权)人(译)	美敦力公司, INC.		
[标]发明人	GHOSH SUBHAM GILLBERG JEFFREY M STADLER ROBERT W		
发明人	GHOSH, SUBHAM GILLBERG, JEFFREY M. STADLER, ROBERT W.		
IPC分类号	G06G7/48 A61B5/0408 A61B5/0402 A61B5/02 A61B5/05 A61B5/0452 A61B5/04 A61N1/04 A61B5/044 A61B5/00 A61N1/368 A61N1/362		
CPC分类号	A61B5/04012 A61B5/02 A61B5/0402 A61B5/044 A61B5/0452 A61B5/04085 A61N1/3684 A61B5/742 A61N1/0476 A61N1/0484 A61N1/3627 A61N1/3682 A61B5/05 A61N1/36842 A61N1/36843		
审查员(译)	THANGAVELU, KANDASAMY		
优先权	61/482053 2011-05-03 US		
其他公开文献	US20150216434A1		
外部链接	Espacenet USPTO		

摘要(译)

描述了用于评估心脏电不同步的技术。在一些示例中，确定多个躯干表面电位信号中的每一个的激活时间。可以分析或呈现这些激活时间的分散或顺序，以提供患者心脏的电不同步的各种指示。在一些示例中，电极组的电极的位置以及因此感测躯干表面电位信号的位置可以投影在包括模型心脏的模型躯干的表面上。可以解决心电图的反问题，以基于从患者感测到的躯干表面电位信号确定模型心脏区域的电激活时间。

