



US009668680B2

(12) **United States Patent**
Bruinsma et al.

(10) **Patent No.:** **US 9,668,680 B2**
(45) **Date of Patent:** ***Jun. 6, 2017**

(54) **EMITTER DRIVER FOR NONINVASIVE PATIENT MONITOR**

(58) **Field of Classification Search**
USPC 600/310
See application file for complete search history.

(71) Applicant: **Masimo Corporation**, Irvine, CA (US)

(72) Inventors: **Johannes Bruinsma**, Opeinde (NL);
Cristiano Dalvi, Lake Forest, CA (US);
Marcelo Lamego, Cupertino, CA (US)

(56) **References Cited**

U.S. PATENT DOCUMENTS

3,910,701 A 10/1975 Henderson et al.
4,114,604 A 9/1978 Shaw et al.
4,258,719 A 3/1981 Lewyn

(Continued)

FOREIGN PATENT DOCUMENTS

EP 419223 3/1991
JP 05-325705 A 12/1993

(Continued)

(73) Assignee: **MASIMO CORPORATION**, Irvine, CA (US)

(*) Notice: Subject to any disclaimer, the term of this patent is extended or adjusted under 35 U.S.C. 154(b) by 0 days.

This patent is subject to a terminal disclaimer.

(21) Appl. No.: **14/942,185**

OTHER PUBLICATIONS

(22) Filed: **Nov. 16, 2015**

PCT International Search Report, App. No. PCT/US2010/047899,
Date of Actual Completion of Search: Jan. 26, 2011, 4 pages.

(Continued)

(65) **Prior Publication Data**

US 2016/0166188 A1 Jun. 16, 2016

Related U.S. Application Data

(63) Continuation of application No. 14/227,230, filed on Mar. 27, 2014, now Pat. No. 9,186,102, which is a continuation of application No. 12/875,062, filed on Sep. 2, 2010, now Pat. No. 8,688,183.

Primary Examiner — Minh Phan

(74) *Attorney, Agent, or Firm* — Knobbe, Martens, Olson & Bear LLP

(60) Provisional application No. 61/239,741, filed on Sep. 3, 2009.

(57) **ABSTRACT**

Embodiments of the present disclosure include an emitter driver configured to be capable of addressing substantially 2^N nodes with N cable conductors configured to carry activation instructions from a processor. In an embodiment, an address controller outputs an activation instruction to a latch decoder configured to supply switch controls to activate particular LEDs of a light source.

(51) **Int. Cl.**

A61B 5/00 (2006.01)

A61B 5/1455 (2006.01)

(52) **U.S. Cl.**

CPC **A61B 5/14552** (2013.01); **A61B 5/0059** (2013.01); **A61B 5/6826** (2013.01); **A61B 2560/045** (2013.01); **A61B 2562/0233** (2013.01); **A61B 2562/046** (2013.01); **A61B 2562/222** (2013.01)

20 Claims, 10 Drawing Sheets

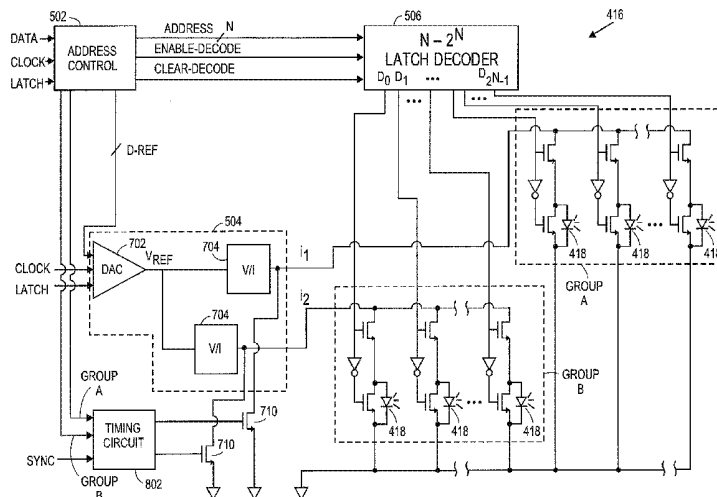

(56)

References Cited

U.S. PATENT DOCUMENTS

4,267,844 A	5/1981	Yamanishi	5,743,262 A	4/1998	Lepper, Jr. et al.
4,444,471 A	4/1984	Ford et al.	5,750,927 A	5/1998	Baltazar
4,655,225 A	4/1987	Dahne et al.	5,752,914 A	5/1998	Delonzor et al.
4,684,245 A	8/1987	Goldring	5,758,644 A	6/1998	Diab et al.
4,755,676 A	7/1988	Gaalema et al.	5,760,910 A	6/1998	Lepper, Jr. et al.
4,781,195 A	11/1988	Martin	5,766,131 A	6/1998	Kondo et al.
4,805,623 A	2/1989	Jöbbsis	5,769,785 A	6/1998	Diab et al.
4,880,304 A	11/1989	Jaeb et al.	5,782,757 A	7/1998	Diab et al.
4,960,128 A	10/1990	Gordon et al.	5,785,659 A	7/1998	Caro et al.
4,964,408 A	10/1990	Hink et al.	5,791,347 A	8/1998	Flaherty et al.
5,028,787 A	7/1991	Rosenthal et al.	5,792,052 A	8/1998	Isaacson et al.
5,035,243 A	7/1991	Muz	5,810,734 A	9/1998	Caro et al.
5,041,187 A	8/1991	Hink et al.	5,823,950 A	10/1998	Diab et al.
5,043,820 A	8/1991	Wyles et al.	5,826,885 A	10/1998	Helgeland
5,069,213 A	12/1991	Polczynski	5,830,131 A	11/1998	Caro et al.
5,069,214 A	12/1991	Samaras et al.	5,833,618 A	11/1998	Caro et al.
5,077,476 A	12/1991	Rosenthal	D403,070 S	12/1998	Maeda et al.
5,086,229 A	2/1992	Rosenthal et al.	5,851,178 A	12/1998	Aronow
D326,715 S	6/1992	Schmidt	5,860,919 A	1/1999	Kiani-Azarbayjany et al.
5,122,925 A	6/1992	Inpyn	5,890,929 A	4/1999	Mills et al.
5,131,391 A	7/1992	Sakai et al.	5,902,235 A	5/1999	Lewis et al.
5,137,023 A	8/1992	Mendelson et al.	5,903,357 A	5/1999	Colak
5,159,929 A	11/1992	McMillen et al.	5,904,654 A	5/1999	Wohlmann et al.
5,163,438 A	11/1992	Gordon et al.	5,919,134 A	7/1999	Diab
5,222,295 A	6/1993	Dpriss, Jr.	5,934,925 A	8/1999	Tobler et al.
5,222,495 A	6/1993	Clarke et al.	5,940,182 A	8/1999	Lepper, Jr. et al.
5,222,496 A	6/1993	Clarke et al.	5,957,840 A	9/1999	Terasawa et al.
5,249,576 A	10/1993	Goldberger et al.	D414,870 S	10/1999	Saltzstein et al.
5,250,342 A	10/1993	Lang	5,995,855 A	11/1999	Kiani et al.
5,278,627 A	1/1994	Aoyagi et al.	5,997,343 A	12/1999	Mills et al.
5,297,548 A	3/1994	Pologe	6,002,952 A	12/1999	Diab et al.
5,319,355 A	6/1994	Russek	6,011,986 A	1/2000	Diab et al.
5,337,744 A	8/1994	Branigan	6,027,452 A	2/2000	Flaherty et al.
5,337,745 A	8/1994	Benaron	6,036,642 A	3/2000	Diab et al.
5,341,805 A	8/1994	Stavridi et al.	6,045,509 A	4/2000	Caro et al.
5,362,966 A	11/1994	Rosenthal et al.	6,049,727 A	4/2000	Crothall
D353,195 S	12/1994	Savage et al.	6,067,462 A	5/2000	Diab et al.
D353,196 S	12/1994	Savage et al.	6,081,735 A	6/2000	Diab et al.
5,377,676 A	1/1995	Vari et al.	6,088,607 A	7/2000	Diab et al.
D356,870 S	3/1995	Ivers et al.	6,110,522 A	8/2000	Lepper, Jr. et al.
D359,546 S	6/1995	Savage et al.	6,124,597 A	9/2000	Shehada
5,427,093 A	6/1995	Ogawa et al.	6,128,521 A	10/2000	Marro et al.
5,431,170 A	7/1995	Mathews	6,129,675 A	10/2000	Jay
D361,840 S	8/1995	Savage et al.	6,144,866 A	11/2000	Miesel et al.
5,437,275 A	8/1995	Amundsen et al.	6,144,868 A	11/2000	Parker
5,441,054 A	8/1995	Tsuchiya	6,151,516 A	11/2000	Kiani-Azarbayjany et al.
D362,063 S	9/1995	Savage et al.	6,152,754 A	11/2000	Gerhardt et al.
5,452,717 A	9/1995	Branigan et al.	6,157,850 A	12/2000	Diab et al.
D363,120 S	10/1995	Savage et al.	6,165,005 A	12/2000	Mills et al.
5,456,252 A	10/1995	Vari et al.	6,172,743 B1	1/2001	Kley et al.
5,479,934 A	1/1996	Imran	6,181,958 B1	1/2001	Steuer et al.
5,482,034 A	1/1996	Lewis et al.	6,184,521 B1	2/2001	Coffin, IV et al.
5,482,036 A	1/1996	Diab et al.	6,206,830 B1	3/2001	Diab et al.
5,490,505 A	2/1996	Diab et al.	6,223,063 B1	4/2001	Chaiken et al.
5,494,043 A	2/1996	O'Sullivan et al.	6,229,856 B1	5/2001	Diab et al.
5,511,546 A	4/1996	Hon	6,232,609 B1	5/2001	Snyder et al.
5,533,511 A	7/1996	Kaspari et al.	6,236,872 B1	5/2001	Diab et al.
5,534,851 A	7/1996	Russek	6,241,683 B1	6/2001	Macklem et al.
5,551,422 A	9/1996	Simonsen et al.	6,253,097 B1	6/2001	Aronow et al.
5,553,615 A	9/1996	Carim et al.	6,256,523 B1	7/2001	Diab et al.
5,553,616 A	9/1996	Ham et al.	6,263,222 B1	7/2001	Diab et al.
5,561,275 A	10/1996	Savage et al.	6,278,522 B1	8/2001	Lepper, Jr. et al.
5,562,002 A	10/1996	Lalin	6,278,889 B1	8/2001	Robinson
5,590,649 A	1/1997	Caro et al.	6,280,213 B1	8/2001	Tobler et al.
5,602,924 A	2/1997	Durand et al.	6,285,896 B1	9/2001	Tobler et al.
D378,414 S	3/1997	Allen et al.	6,301,493 B1	10/2001	Marro et al.
5,625,458 A	4/1997	Alfano et al.	6,317,627 B1	11/2001	Ennen et al.
5,632,272 A	5/1997	Diab et al.	6,321,100 B1	11/2001	Parker
5,638,816 A	6/1997	Kiani-Azarbayjany et al.	D452,012 S	12/2001	Phillips
5,638,818 A	6/1997	Diab et al.	6,325,761 B1	12/2001	Jay
5,645,440 A	7/1997	Tobler et al.	6,334,065 B1	12/2001	Al-Ali et al.
5,676,143 A	10/1997	Simonsen et al.	6,343,223 B1	1/2002	Chin et al.
5,685,299 A	11/1997	Diab et al.	6,343,224 B1	1/2002	Parker
D390,666 S	2/1998	Lagerlof	6,345,194 B1	2/2002	Nelson et al.
D393,830 S	4/1998	Tobler et al.	6,349,228 B1	2/2002	Kiani et al.
			6,353,750 B1	3/2002	Kimura et al.
			6,360,113 B1	3/2002	Dettling
			6,360,114 B1	3/2002	Diab et al.
			6,360,115 B1	3/2002	Greenwald et al.

(56)

References Cited

U.S. PATENT DOCUMENTS

D455,834	S	4/2002	Donars et al.	6,912,413	B2	6/2005	Rantala et al.
6,368,283	B1	4/2002	Xu et al.	6,920,345	B2	7/2005	Al-Ali et al.
6,371,921	B1	4/2002	Caro et al.	D508,862	S	8/2005	Behar et al.
6,377,829	B1	4/2002	Al-Ali	6,931,268	B1	8/2005	Kiani-Azarbayjany et al.
6,388,240	B2	5/2002	Schulz et al.	6,934,570	B2	8/2005	Kiani et al.
6,397,091	B2	5/2002	Diab et al.	6,939,305	B2	9/2005	Flaherty et al.
6,430,437	B1	8/2002	Marro	6,943,348	B1	9/2005	Coffin, IV
6,430,525	B1	8/2002	Weber et al.	6,950,687	B2	9/2005	Al-Ali
D463,561	S	9/2002	Fukatsu et al.	D510,625	S	10/2005	Widener et al.
6,463,311	B1	10/2002	Diab	6,961,598	B2	11/2005	Diab
6,470,199	B1	10/2002	Kopotic et al.	6,970,792	B1	11/2005	Diab
6,501,975	B2	12/2002	Diab et al.	6,979,812	B2	12/2005	Al-Ali
6,505,059	B1	1/2003	Kollias et al.	6,985,764	B2	1/2006	Mason et al.
6,515,273	B2	2/2003	Al-Ali	6,993,371	B2	1/2006	Kiani et al.
6,519,487	B1	2/2003	Parker	D514,461	S	2/2006	Harju
6,522,521	B2	2/2003	Mizuno et al.	6,995,400	B2	2/2006	Mizuyoshi
6,525,386	B1	2/2003	Mills et al.	6,996,427	B2	2/2006	Ali et al.
6,526,300	B1	2/2003	Kiani et al.	6,999,904	B2	2/2006	Weber et al.
6,541,756	B2	4/2003	Schulz et al.	7,003,338	B2	2/2006	Weber et al.
6,542,764	B1	4/2003	Al-Ali et al.	7,003,339	B2	2/2006	Diab et al.
6,580,086	B1	6/2003	Schulz et al.	7,015,451	B2	3/2006	Dalke et al.
6,584,336	B1	6/2003	Ali et al.	7,024,233	B2	4/2006	Ali et al.
6,595,316	B2	7/2003	Cybulski et al.	7,027,849	B2	4/2006	Al-Ali
6,597,932	B2	7/2003	Tian et al.	7,030,749	B2	4/2006	Al-Ali
6,597,933	B2	7/2003	Kiani et al.	7,039,449	B2	5/2006	Al-Ali
6,606,509	B2	8/2003	Schmitt	7,041,060	B2	5/2006	Flaherty et al.
6,606,511	B1	8/2003	Ali et al.	7,044,918	B2	5/2006	Diab
D481,459	S	10/2003	Nahm	7,047,054	B2	5/2006	Benni
6,632,181	B2	10/2003	Flaherty et al.	7,067,893	B2	6/2006	Mills et al.
6,636,759	B2	10/2003	Robinson	7,092,757	B2	8/2006	Larson et al.
6,639,668	B1	10/2003	Trepagnier	7,096,052	B2	8/2006	Mason et al.
6,639,867	B2	10/2003	Shim	7,096,054	B2	8/2006	Abdul-Hafiz et al.
6,640,116	B2	10/2003	Diab	7,132,641	B2	11/2006	Schulz et al.
6,643,530	B2	11/2003	Diab et al.	7,142,901	B2	11/2006	Kiani et al.
6,650,917	B2	11/2003	Diab et al.	7,149,561	B2	12/2006	Diab
6,654,624	B2	11/2003	Diab et al.	D535,031	S	1/2007	Barrett et al.
6,658,276	B2	12/2003	Kianl et al.	D537,164	S	2/2007	Shigemori et al.
6,661,161	B1	12/2003	Lanzo et al.	7,186,966	B2	3/2007	Al-Ali
6,668,185	B2	12/2003	Toida	7,190,261	B2	3/2007	Al-Ali
6,671,531	B2	12/2003	Al-Ali et al.	7,215,984	B2	5/2007	Diab
6,678,543	B2	1/2004	Diab et al.	7,215,986	B2	5/2007	Diab
6,681,133	B2	1/2004	Chaiken et al.	7,221,971	B2	5/2007	Diab
6,684,090	B2	1/2004	Ali et al.	7,225,006	B2	5/2007	Al-Ali et al.
6,684,091	B2	1/2004	Parker	7,225,007	B2	5/2007	Al-Ali
6,697,656	B1	2/2004	Al-Ali	RE39,672	E	6/2007	Shehada et al.
6,697,657	B1	2/2004	Shehada et al.	7,230,227	B2	6/2007	Wilcken et al.
6,697,658	B2	2/2004	Al-Ali	D547,454	S	7/2007	Hsieh
RE38,476	E	3/2004	Diab et al.	7,239,905	B2	7/2007	Kiani-Azarbayjany et al.
6,699,194	B1	3/2004	Diab et al.	7,245,953	B1	7/2007	Parker
6,714,804	B2	3/2004	Al-Ali et al.	D549,830	S	8/2007	Behar et al.
RE38,492	E	4/2004	Diab et al.	7,254,429	B2	8/2007	Schurman et al.
6,721,582	B2	4/2004	Trepagnier et al.	7,254,431	B2	8/2007	Al-Ali
6,721,585	B1	4/2004	Parker	7,254,433	B2	8/2007	Diab et al.
6,725,075	B2	4/2004	Al-Ali	7,254,434	B2	8/2007	Schulz et al.
6,728,560	B2	4/2004	Kollias et al.	D550,364	S	9/2007	Glover et al.
6,735,459	B2	5/2004	Parker	D551,350	S	9/2007	Lorimer et al.
6,745,060	B2	6/2004	Diab et al.	7,272,425	B2	9/2007	Al-Ali
6,748,254	B2	6/2004	O'Neil et al.	7,274,955	B2	9/2007	Kiani et al.
6,760,607	B2	7/2004	Al-Ali	D553,248	S	10/2007	Nguyen
6,770,028	B1	8/2004	Ali et al.	D554,263	S	10/2007	Al-Ali
6,771,994	B2	8/2004	Kiani et al.	7,280,858	B2	10/2007	Al-Ali et al.
6,792,300	B1	9/2004	Diab et al.	7,289,835	B2	10/2007	Mansfield et al.
6,813,511	B2	11/2004	Diab et al.	7,292,883	B2	11/2007	De Felice et al.
6,816,010	B2	11/2004	Seetharaman et al.	7,295,866	B2	11/2007	Al-Ali
6,816,241	B2	11/2004	Grubisic et al.	D562,985	S	2/2008	Brefka et al.
6,816,741	B2	11/2004	Diab	7,328,053	B1	2/2008	Diab et al.
6,822,564	B2	11/2004	Al-Ali	7,332,784	B2	2/2008	Mills et al.
6,826,419	B2	11/2004	Diab et al.	7,340,287	B2	3/2008	Mason et al.
6,830,711	B2	12/2004	Mills et al.	7,341,559	B2	3/2008	Schulz et al.
6,850,787	B2	2/2005	Weber et al.	7,343,186	B2	3/2008	Lamego et al.
6,850,788	B2	2/2005	Al-Ali	D566,282	S	4/2008	Al-Ali et al.
6,852,083	B2	2/2005	Caro et al.	D567,125	S	4/2008	Okabe et al.
D502,655	S	3/2005	Huang	7,355,512	B1	4/2008	Al-Ali
6,861,639	B2	3/2005	Al-Ali	7,356,365	B2	4/2008	Schurman
6,898,452	B2	5/2005	Al-Ali et al.	7,365,923	B2	4/2008	Hargis et al.
				D569,001	S	5/2008	Omaki
				D569,521	S	5/2008	Omaki
				7,371,981	B2	5/2008	Abdul-Hafiz
				7,373,193	B2	5/2008	Al-Ali et al.

(56)

References Cited

U.S. PATENT DOCUMENTS

7,373,194 B2	5/2008	Weber et al.	7,941,199 B2	5/2011	Kiani
7,376,453 B1	5/2008	Diab et al.	7,951,086 B2	5/2011	Flaherty et al.
7,377,794 B2	5/2008	Al Ali et al.	7,957,780 B2	6/2011	Lamego et al.
7,377,899 B2	5/2008	Weber et al.	7,962,188 B2	6/2011	Kiani et al.
7,383,070 B2	6/2008	Diab et al.	7,962,190 B1	6/2011	Diab et al.
7,395,189 B2	7/2008	Qing et al.	7,976,472 B2	7/2011	Kiani
7,415,297 B2	8/2008	Al-Ali et al.	7,988,637 B2	8/2011	Diab
7,428,432 B2	9/2008	Ali et al.	7,990,382 B2	8/2011	Kiani
7,438,683 B2	10/2008	Al-Ali et al.	7,991,446 B2	8/2011	Al-Ali et al.
7,440,787 B2	10/2008	Diab	8,000,761 B2	8/2011	Al-Ali
7,454,240 B2	11/2008	Diab et al.	8,008,088 B2	8/2011	Bellott et al.
7,467,002 B2	12/2008	Weber et al.	RE42,753 E	9/2011	Kiani-Azarbayjany et al.
7,469,157 B2	12/2008	Diab et al.	8,019,400 B2	9/2011	Diab et al.
7,471,969 B2	12/2008	Diab et al.	8,028,701 B2	10/2011	Al-Ali et al.
7,471,971 B2	12/2008	Diab et al.	8,029,765 B2	10/2011	Bellott et al.
7,483,729 B2	1/2009	Al-Ali et al.	8,036,728 B2	10/2011	Diab et al.
7,483,730 B2	1/2009	Diab et al.	8,044,998 B2	10/2011	Heenan
7,489,958 B2	2/2009	Diab et al.	8,046,040 B2	10/2011	Ali et al.
7,496,391 B2	2/2009	Diab et al.	8,046,041 B2	10/2011	Diab et al.
7,496,393 B2	2/2009	Diab et al.	8,046,042 B2	10/2011	Diab et al.
D587,657 S	3/2009	Al-Ali et al.	8,048,040 B2	11/2011	Kiani
7,499,741 B2	3/2009	Diab et al.	8,050,728 B2	11/2011	Al-Ali et al.
7,499,835 B2	3/2009	Weber et al.	RE43,169 E	2/2012	Parker
7,500,950 B2	3/2009	Al-Ali et al.	8,118,620 B2	2/2012	Al-Ali et al.
7,509,153 B2	3/2009	Blank et al.	8,126,528 B2	2/2012	Diab et al.
7,509,154 B2	3/2009	Diab et al.	8,126,531 B2	2/2012	Crowley
7,509,494 B2	3/2009	Al-Ali	8,128,572 B2	3/2012	Diab et al.
7,510,849 B2	3/2009	Schurman et al.	8,130,105 B2	3/2012	Al-Ali et al.
7,526,328 B2	4/2009	Diab et al.	8,145,287 B2	3/2012	Diab et al.
7,530,942 B1	5/2009	Diab	8,150,487 B2	4/2012	Diab et al.
7,530,949 B2	5/2009	Al Ali et al.	8,175,672 B2	5/2012	Parker
7,530,955 B2	5/2009	Diab et al.	8,180,420 B2	5/2012	Diab et al.
7,563,110 B2	7/2009	Al-Ali et al.	8,182,443 B1	5/2012	Kiani
7,596,398 B2	9/2009	Al-Ali et al.	8,185,180 B2	5/2012	Diab et al.
7,606,606 B2	10/2009	Laakkonen	8,190,223 B2	5/2012	Al-Ali et al.
D603,966 S	11/2009	Jones et al.	8,190,227 B2	5/2012	Diab et al.
7,618,375 B2	11/2009	Flaherty	8,203,438 B2	6/2012	Kiani et al.
D606,659 S	12/2009	Kiani et al.	8,203,704 B2	6/2012	Merritt et al.
7,647,083 B2	1/2010	Al-Ali et al.	8,219,170 B2	7/2012	Hausmann et al.
D609,193 S	2/2010	Al-Ali et al.	8,224,411 B2	7/2012	Al-Ali et al.
7,657,294 B2	2/2010	Eghbal et al.	8,228,181 B2	7/2012	Al-Ali
7,657,295 B2	2/2010	Coakley et al.	8,229,533 B2	7/2012	Diab et al.
7,657,296 B2	2/2010	Raridan et al.	8,233,955 B2	7/2012	Al-Ali et al.
D614,305 S	4/2010	Al-Ali et al.	8,244,325 B2	8/2012	Al-Ali et al.
RE41,317 E	5/2010	Parker	8,255,026 B1	8/2012	Al-Ali
7,729,733 B2	6/2010	Al-Ali et al.	8,255,027 B2	8/2012	Al-Ali et al.
7,734,320 B2	6/2010	Al-Ali	8,255,028 B2	8/2012	Al-Ali et al.
7,761,127 B2	7/2010	Al-Ali et al.	8,260,577 B2	9/2012	Weber et al.
7,761,128 B2	7/2010	Al-Ali et al.	8,265,723 B1	9/2012	McHale et al.
7,764,982 B2	7/2010	Dalke et al.	8,274,360 B2	9/2012	Sampath et al.
D621,516 S	8/2010	Kiani et al.	8,301,217 B2	10/2012	Al-Ali et al.
7,791,155 B2	9/2010	Diab	8,306,596 B2	11/2012	Schurman et al.
7,801,581 B2	9/2010	Diab	8,310,336 B2	11/2012	Muhsin et al.
7,809,418 B2	10/2010	Xu	8,315,683 B2	11/2012	Al-Ali et al.
7,822,452 B2	10/2010	Schurman et al.	RE43,860 E	12/2012	Parker
RE41,912 E	11/2010	Parker	8,332,006 B2	12/2012	Naganuma et al.
7,844,313 B2	11/2010	Kiani et al.	8,337,403 B2	12/2012	Al-Ali et al.
7,844,314 B2	11/2010	Al-Ali	8,346,330 B2	1/2013	Lamego
7,844,315 B2	11/2010	Al-Ali	8,353,842 B2	1/2013	Al-Ali et al.
7,865,222 B2	1/2011	Weber et al.	8,355,766 B2	1/2013	MacNeish, III et al.
7,873,497 B2	1/2011	Weber et al.	8,359,080 B2	1/2013	Diab et al.
7,880,606 B2	2/2011	Al-Ali	8,364,223 B2	1/2013	Al-Ali et al.
7,880,626 B2	2/2011	Al-Ali et al.	8,364,226 B2	1/2013	Diab et al.
7,891,355 B2	2/2011	Al-Ali et al.	8,374,665 B2	2/2013	Lamego
7,894,868 B2	2/2011	Al-Ali et al.	8,380,272 B2	2/2013	Barrett et al.
7,899,506 B2	3/2011	Xu et al.	8,385,995 B2	2/2013	Al-ali et al.
7,899,507 B2	3/2011	Al-Ali et al.	8,385,996 B2	2/2013	Smith et al.
7,899,518 B2	3/2011	Trepagnier et al.	8,388,353 B2	3/2013	Kiani et al.
7,904,132 B2	3/2011	Weber et al.	8,399,822 B2	3/2013	Al-Ali
7,909,772 B2	3/2011	Popov et al.	8,401,602 B2	3/2013	Kiani
7,910,875 B2	3/2011	Al-Ali	8,405,608 B2	3/2013	Al-Ali et al.
7,919,713 B2	4/2011	Al-Ali et al.	8,414,499 B2	4/2013	Al-Ali et al.
7,937,128 B2	5/2011	Al-Ali	8,418,524 B2	4/2013	Al-Ali
7,937,129 B2	5/2011	Mason et al.	8,421,022 B2	4/2013	Rozenfeld
7,937,130 B2	5/2011	Diab et al.	8,423,106 B2	4/2013	Lamego et al.
			8,428,674 B2	4/2013	Duffy et al.
			8,428,967 B2	4/2013	Olsen et al.
			8,430,817 B1	4/2013	Al-Ali et al.
			8,437,825 B2	5/2013	Dalvi et al.

(56)

References Cited

U.S. PATENT DOCUMENTS

8,455,290 B2	6/2013	Siskavich	8,781,544 B2	7/2014	Al-Ali et al.
8,457,703 B2	6/2013	Al-Ali	8,781,549 B2	7/2014	Al-Ali et al.
8,457,707 B2	6/2013	Kiani	8,788,003 B2	7/2014	Schurman et al.
8,463,349 B2	6/2013	Diab et al.	8,790,268 B2	7/2014	Al-Ali
8,466,286 B2	6/2013	Bellot et al.	8,801,613 B2	8/2014	Al-Ali et al.
8,471,713 B2	6/2013	Poeze et al.	8,821,397 B2	9/2014	Al-Ali et al.
8,473,020 B2	6/2013	Kiani et al.	8,821,415 B2	9/2014	Al-Ali et al.
8,483,787 B2	7/2013	Al-Ali et al.	8,830,449 B1	9/2014	Lamego et al.
8,489,364 B2	7/2013	Weber et al.	8,831,700 B2	9/2014	Schurman et al.
8,498,684 B2	7/2013	Weber et al.	8,840,549 B2	9/2014	Al-Ali et al.
8,504,128 B2	8/2013	Blank et al.	8,847,740 B2	9/2014	Kiani et al.
8,509,867 B2	8/2013	Workman et al.	8,849,365 B2	9/2014	Smith et al.
8,515,509 B2	8/2013	Bruinsma et al.	8,852,094 B2	10/2014	Al-Ali et al.
8,523,781 B2	9/2013	Al-Ali	8,852,994 B2	10/2014	Wojtczuk et al.
8,529,301 B2	9/2013	Al-Ali et al.	8,868,147 B2	10/2014	Stippick et al.
8,532,727 B2	9/2013	Ali et al.	8,868,150 B2	10/2014	Al-Ali et al.
8,532,728 B2	9/2013	Diab et al.	8,870,792 B2	10/2014	Al-Ali et al.
D692,145 S	10/2013	Al-Ali et al.	8,886,271 B2	11/2014	Kiani et al.
8,547,209 B2	10/2013	Kiani et al.	8,888,539 B2	11/2014	Al-Ali et al.
8,548,548 B2	10/2013	Al-Ali	8,888,708 B2	11/2014	Diab et al.
8,548,549 B2	10/2013	Schurman et al.	8,892,180 B2	11/2014	Weber et al.
8,548,550 B2	10/2013	Al-Ali et al.	8,897,847 B2	11/2014	Al-Ali
8,560,032 B2	10/2013	Al-Ali et al.	8,909,310 B2	12/2014	Lamego et al.
8,560,034 B1	10/2013	Diab et al.	8,911,377 B2	12/2014	Al-Ali
8,570,167 B2	10/2013	Al-Ali	8,912,909 B2	12/2014	Al-Ali et al.
8,570,503 B2	10/2013	Vo	8,920,317 B2	12/2014	Al-Ali et al.
8,571,617 B2	10/2013	Reichgott et al.	8,921,699 B2	12/2014	Al-Ali et al.
8,571,618 B1	10/2013	Lamego et al.	8,922,382 B2	12/2014	Al-Ali et al.
8,571,619 B2	10/2013	Al-Ali et al.	8,929,964 B2	1/2015	Al-Ali et al.
8,577,431 B2	11/2013	Lamego et al.	8,942,777 B2	1/2015	Diab et al.
8,581,732 B2	11/2013	Al-Ali et al.	8,948,834 B2	2/2015	Diab et al.
8,584,345 B2	11/2013	Al-Ali	8,948,835 B2	2/2015	Diab
8,588,880 B2	11/2013	Abdul-Hafiz et al.	8,965,471 B2	2/2015	Lamego
8,600,467 B2	12/2013	Al-Ali et al.	8,983,564 B2	3/2015	Al-Ali
8,602,971 B2	12/2013	Farr	8,989,831 B2	3/2015	Al-Ali et al.
8,606,342 B2	12/2013	Diab	8,996,085 B2	3/2015	Kiani et al.
8,626,255 B2	1/2014	Al-Ali et al.	8,998,809 B2	4/2015	Kiani
8,630,691 B2	1/2014	Lamego et al.	9,028,429 B2	5/2015	Telfort et al.
8,634,889 B2	1/2014	Al-Ali et al.	9,037,207 B2	5/2015	Al-Ali et al.
8,641,631 B2	2/2014	Sierra et al.	9,060,721 B2	6/2015	Reichgott et al.
8,652,060 B2	2/2014	Al-Ali	9,066,666 B2	6/2015	Kiani
8,663,107 B2	3/2014	Kiani	9,066,680 B1	6/2015	Al-Ali et al.
8,666,468 B1	3/2014	Al-Ali	9,072,474 B2	7/2015	Al-Ali et al.
8,667,967 B2	3/2014	Al-Ali et al.	9,078,560 B2	7/2015	Schurman et al.
8,670,811 B2	3/2014	O'Reilly	9,084,569 B2	7/2015	Weber et al.
8,670,814 B2	3/2014	Diab et al.	9,095,316 B2	8/2015	Welch et al.
8,676,286 B2	3/2014	Weber et al.	9,106,038 B2	8/2015	Telfort et al.
8,682,407 B2	3/2014	Al-Ali	9,107,625 B2	8/2015	Telfort et al.
RE44,823 E	4/2014	Parker	9,107,626 B2	8/2015	Al-Ali et al.
RE44,875 E	4/2014	Kiani et al.	9,113,831 B2	8/2015	Al-Ali
8,688,183 B2	4/2014	Bruinsma et al.	9,113,832 B2	8/2015	Al-Ali
8,690,799 B2	4/2014	Telfort et al.	9,119,595 B2	9/2015	Lamego
8,700,112 B2	4/2014	Kiani	9,131,881 B2	9/2015	Diab et al.
8,702,627 B2	4/2014	Telfort et al.	9,131,882 B2	9/2015	Al-Ali et al.
8,706,179 B2	4/2014	Parker	9,131,883 B2	9/2015	Al-Ali
8,712,494 B1	4/2014	MacNeish, III et al.	9,131,917 B2	9/2015	Telfort et al.
8,715,206 B2	5/2014	Telfort et al.	9,138,180 B1	9/2015	Coverston et al.
8,718,735 B2	5/2014	Lamego et al.	9,138,182 B2	9/2015	Al-Ali et al.
8,718,737 B2	5/2014	Diab et al.	9,138,192 B2	9/2015	Weber et al.
8,718,738 B2	5/2014	Blank et al.	9,142,117 B2	9/2015	Muhsin et al.
8,720,249 B2	5/2014	Al-Ali	9,153,112 B1	10/2015	Kiani et al.
8,721,541 B2	5/2014	Al-Ali et al.	9,153,121 B2	10/2015	Kiani et al.
8,721,542 B2	5/2014	Al-Ali et al.	9,161,696 B2	10/2015	Al-Ali et al.
8,723,677 B1	5/2014	Kiani	9,161,713 B2	10/2015	Al-Ali et al.
8,740,792 B1	6/2014	Kiani et al.	9,167,995 B2	10/2015	Lamego et al.
8,754,776 B2	6/2014	Poeze et al.	9,176,141 B2	11/2015	Al-Ali et al.
8,755,535 B2	6/2014	Telfort et al.	9,186,102 B2	11/2015	Bruinsma et al.
8,755,856 B2	6/2014	Diab et al.	9,192,312 B2	11/2015	Al-Ali
8,755,872 B1	6/2014	Marinow	9,192,329 B2	11/2015	Al-Ali
8,761,850 B2	6/2014	Lamego	9,192,351 B1	11/2015	Telfort et al.
8,764,671 B2	7/2014	Kiani	9,195,385 B2	11/2015	Al-Ali et al.
8,768,423 B2	7/2014	Shakespeare et al.	9,211,072 B2	12/2015	Kiani
8,771,204 B2	7/2014	Telfort et al.	9,211,095 B1	12/2015	Al-Ali
8,777,634 B2	7/2014	Kiani et al.	9,218,454 B2	12/2015	Kiani et al.
8,781,543 B2	7/2014	Diab et al.	9,226,696 B2	1/2016	Kiani
			9,241,662 B2	1/2016	Al-Ali et al.
			9,245,668 B1	1/2016	Vo et al.
			9,259,185 B2	2/2016	Abdul-Hafiz et al.
			9,267,572 B2	2/2016	Barker et al.

(56)

References Cited

U.S. PATENT DOCUMENTS

9,277,880 B2	3/2016	Poeze et al.	2014/0058230 A1	2/2014	Abdul-Hafiz et al.
9,289,167 B2	3/2016	Diab et al.	2014/0066783 A1	3/2014	Kiani et al.
9,295,421 B2	3/2016	Kiani et al.	2014/0077956 A1	3/2014	Sampath et al.
9,307,928 B1	4/2016	Al-Ali et al.	2014/0081100 A1	3/2014	Muhsin et al.
9,323,894 B2	4/2016	Kiani	2014/0081175 A1	3/2014	Telfort
D755,392 S	5/2016	Hwang et al.	2014/0094667 A1	4/2014	Schurman et al.
9,326,712 B1	5/2016	Kiani	2014/0100434 A1	4/2014	Diab et al.
9,333,316 B2	5/2016	Kiani	2014/0114199 A1	4/2014	Lamego et al.
9,339,220 B2	5/2016	Lamego et al.	2014/0120564 A1	5/2014	Workman et al.
9,341,565 B2	5/2016	Lamego et al.	2014/0121482 A1	5/2014	Merritt et al.
9,351,673 B2	5/2016	Diab et al.	2014/0121483 A1	5/2014	Kiani
9,351,675 B2	5/2016	Al-Ali et al.	2014/0127137 A1	5/2014	Bellott et al.
9,364,181 B2	6/2016	Kiani et al.	2014/0129702 A1	5/2014	Lamego et al.
9,368,671 B2	6/2016	Wojtczuk et al.	2014/0135588 A1	5/2014	Al-Ali et al.
9,370,325 B2	6/2016	Al-Ali et al.	2014/0142401 A1	5/2014	Al-Ali et al.
9,370,326 B2	6/2016	McHale et al.	2014/0155712 A1	6/2014	Lamego et al.
9,370,335 B2	6/2016	Al-Ali et al.	2014/0163344 A1	6/2014	Al-Ali
9,375,185 B2	6/2016	Ali et al.	2014/0163402 A1	6/2014	Lamego et al.
9,386,953 B2	7/2016	Al-Ali	2014/0166076 A1	6/2014	Kiani et al.
9,386,961 B2	7/2016	Al-Ali et al.	2014/0171763 A1	6/2014	Diab
9,392,945 B2	7/2016	Al-Ali et al.	2014/0180038 A1	6/2014	Kiani
9,397,448 B2	7/2016	Al-Ali et al.	2014/0180154 A1	6/2014	Sierra et al.
2002/0099279 A1	7/2002	Pfeiffer et al.	2014/0194709 A1	7/2014	Al-Ali et al.
2006/0005944 A1	1/2006	Wang et al.	2014/0194711 A1	7/2014	Al-Ali
2006/0025659 A1	2/2006	Kiguchi et al.	2014/0194766 A1	7/2014	Al-Ali et al.
2007/0149864 A1*	6/2007	Laakkonen	2014/0206963 A1	7/2014	Al-Ali
		A61B 5/14551	2014/0213864 A1	7/2014	Abdul-Hafiz et al.
		600/310	2014/0243627 A1	8/2014	Diab et al.
2007/0293792 A1	12/2007	Sliwa et al.	2014/0266790 A1	9/2014	Al-Ali et al.
2008/0130232 A1	6/2008	Yamamoto et al.	2014/0275808 A1	9/2014	Poeze et al.
2008/0139908 A1	6/2008	Kurth	2014/0275835 A1	9/2014	Lamego et al.
2009/0030327 A1	1/2009	Chance	2014/0275871 A1	9/2014	Lamego et al.
2009/0043180 A1	2/2009	Tschautscher et al.	2014/0275872 A1	9/2014	Merritt et al.
2009/0129102 A1	5/2009	Xiao et al.	2014/0275881 A1	9/2014	Lamego et al.
2009/0247984 A1	10/2009	Lamego et al.	2014/0288400 A1	9/2014	Diab et al.
2009/0259114 A1	10/2009	Johnson et al.	2014/0296664 A1	10/2014	Bruinsma et al.
2009/0275844 A1	11/2009	Al-Ali	2014/0303520 A1	10/2014	Telfort et al.
2010/0004518 A1	1/2010	Vo et al.	2014/0316228 A1	10/2014	Blank et al.
2010/0030040 A1	2/2010	Poeze et al.	2014/0323825 A1	10/2014	Al-Ali et al.
2011/0001605 A1	1/2011	Kiani et al.	2014/0330092 A1	11/2014	Al-Ali et al.
2011/0082711 A1	4/2011	Poeze et al.	2014/0330098 A1	11/2014	Merritt et al.
2011/0105854 A1	5/2011	Kiani et al.	2014/0330099 A1	11/2014	Al-Ali et al.
2011/0105865 A1	5/2011	Yu et al.	2014/0333440 A1	11/2014	Kiani
2011/0208015 A1	8/2011	Welch et al.	2014/0336481 A1	11/2014	Shakespeare et al.
2011/0213212 A1	9/2011	Al-Ali	2014/0343436 A1	11/2014	Kiani
2011/0230733 A1	9/2011	Al-Ali	2015/0018650 A1	1/2015	Al-Ali et al.
2011/0237911 A1	9/2011	Lamego et al.	2015/0351697 A1	12/2015	Weber et al.
2012/0059267 A1	3/2012	Lamego et al.	2015/0351704 A1	12/2015	Kiani et al.
2012/0179006 A1	7/2012	Jansen et al.	2015/0359429 A1	12/2015	Al-Ali et al.
2012/0209082 A1	8/2012	Al-Ali	2015/0366472 A1	12/2015	Kiani
2012/0209084 A1	8/2012	Olsen et al.	2015/0366507 A1	12/2015	Blank
2012/0227739 A1	9/2012	Kiani	2015/0374298 A1	12/2015	Al-Ali et al.
2012/0283524 A1	11/2012	Kiani et al.	2015/0380875 A1	12/2015	Coverston et al.
2012/0296178 A1	11/2012	Lamego et al.	2016/0000362 A1	1/2016	Diab et al.
2012/0319816 A1	12/2012	Al-Ali	2016/0007930 A1	1/2016	Weber et al.
2012/0330112 A1	12/2012	Lamego et al.	2016/0029932 A1	2/2016	Al-Ali
2013/0023775 A1	1/2013	Lamego et al.	2016/0029933 A1	2/2016	Al-Ali et al.
2013/0041591 A1	2/2013	Lamego	2016/0045118 A1	2/2016	Kiani
2013/0045685 A1	2/2013	Kiani	2016/0051205 A1	2/2016	Al-Ali et al.
2013/0046204 A1	2/2013	Lamego et al.	2016/0058338 A1	3/2016	Schurman et al.
2013/0060147 A1	3/2013	Welch et al.	2016/0058347 A1	3/2016	Reichgott et al.
2013/0096405 A1	4/2013	Garfio	2016/0066823 A1	3/2016	Al-Ali et al.
2013/0096936 A1	4/2013	Sampath et al.	2016/0066824 A1	3/2016	Al-Ali et al.
2013/0190581 A1	7/2013	Al-Ali et al.	2016/0066879 A1	3/2016	Telfort et al.
2013/0197328 A1	8/2013	Diab et al.	2016/0072429 A1	3/2016	Kiani et al.
2013/0211214 A1	8/2013	Olsen	2016/0073967 A1	3/2016	Lamego et al.
2013/0243021 A1	9/2013	Siskavich	2016/0081552 A1	3/2016	Wojtczuk et al.
2013/0253334 A1	9/2013	Al-Ali et al.	2016/0095543 A1	4/2016	Telfort et al.
2013/0296672 A1	11/2013	O'Neil et al.	2016/0095548 A1	4/2016	Al-Ali et al.
2013/0317370 A1	11/2013	Dalvi et al.	2016/0103598 A1	4/2016	Al-Ali et al.
2013/0324808 A1	12/2013	Al-Ali et al.	2016/0113527 A1	4/2016	Al-Ali et al.
2013/0331670 A1	12/2013	Kiani	2016/0143548 A1	5/2016	Al-Ali
2013/0338461 A1	12/2013	Lamego et al.	2016/0166183 A1	6/2016	Poeze et al.
2014/0012100 A1	1/2014	Al-Ali et al.	2016/0166210 A1	6/2016	Al-Ali
2014/0034353 A1	2/2014	Al-Ali et al.	2016/0192869 A1	7/2016	Kiani et al.
2014/0051953 A1	2/2014	Lamego et al.	2016/0196388 A1	7/2016	Lamego

(56)

References Cited

U.S. PATENT DOCUMENTS

2016/0197436 A1 7/2016 Barker et al.
2016/0213281 A1 7/2016 Eckerbom et al.

FOREIGN PATENT DOCUMENTS

JP	08-185864	7/1996
JP	2001-66990	3/2001
JP	2001-087250 A	4/2001
JP	2002-500908 A	1/2002
JP	2003-024276 A	1/2003
JP	2003-508104 A	3/2003
JP	2003-265444 A	9/2003
JP	2006-177837 A	7/2006
JP	2006-198321 A	8/2006
JP	2007-389463 A	11/2007
JP	2008-099222 A	4/2008
JP	5756752	6/2015
WO	WO 93/12712	7/1993
WO	WO 99/00053	1/1999
WO	WO 99/01704	7/1999
WO	WO 00/25112	5/2000
WO	WO 2014/149781	9/2014
WO	WO 2014/158820	10/2014

OTHER PUBLICATIONS

International Search Report and Written Opinion for PCT/US2009/049638, mailed Jan. 7, 2010.

International Search Report issued in Application No. PCT/US2009/052756, mailed Feb. 10, 2009 in 14 pages.

International Preliminary Report on Patentability and Written Opinion of the International Searching Authority issued in Application No. PCT/US2009/049638, mailed Jan. 5, 2011 in 9 pages.

International Preliminary Report on Patentability and Written Opinion of the International Searching Authority issued in Application No. PCT/US2009/052756, mailed Feb. 8, 2011 in 8 pages.

Burritt, Mary F.; Current Analytical Approaches to Measuring Blood Analytes; vol. 36; No. 8(B); 1990.

Hall, et al., Jeffrey W.; Near-Infrared Spectrophotometry: A New Dimension in Clinical Chemistry; vol. 38; No. 9; 1992.

Kuenstner, et al., J. Todd; Measurement of Hemoglobin in Unlysed Blood by Near-Infrared Spectroscopy; vol. 48; No. 4, 1994.

Manzke, et al., B., Multi Wavelength Pulse Oximetry in the Measurement of Hemoglobin Fractions; SPIE, vol. 2676, Apr. 24, 1996.

Naumenko, E. K.; Choice of Wavelengths for Stable Determination of Concentrations of Hemoglobin Derivatives from Absorption

Spectra of Erythrocytes; vol. 63; No. 1; pp. 60-66 Jan.-Feb. 1996; Original article submitted Nov. 3, 1994.

Schmitt, Joseph M.; Simple Photon Diffusion Analysis of the Effects of Multiple Scattering on Pulse Oximetry; Mar. 14, 1991; revised Aug. 30, 1991.

Schmitt, et al., Joseph M.; Measurement of Blood Hematocrit by Dual-Wavelength near-IR Photoplethysmography; vol. 1641; 1992. Schnapp, et al., L.M.; Pulse Oximetry. Uses and Abuses.; Chest 1990; 98; 1244-1250 DOI 10.1378/Chest.98.5.1244.

<http://www.masimo.com/rainbow/pronto.htm> Noninvasive & Immediate Hemoglobin Testing, printed on Aug. 20, 2009.

<http://www.masimo.com/pulseOximeter/Rad5.htm>; Signal Extraction Pulse Oximeter, printed on Aug. 20, 2009.

http://blogderoliveira.blogspot.com/2008_02_01_archive.html;

Ricardo Oliveira, printed on Aug. 20, 2009.

<http://www.masimo.com/rad-57/>; Noninvasive Measurement of Methemoglobin, Carboxyhemoglobin and Oxyhemoglobin in the blood. Printed on Aug. 20, 2009.

<http://amivital.ugr.es/blog/?tag+spo2>; Monitorizacion de la hemoglobina . . . y mucho mas, printed on Aug. 20, 2009.

<http://www.masimo.com/spco/>; Carboxyhemoglobin Noninvasive > Continuous > Immediate, printed on Aug. 20, 2009.

<http://www.masimo.com/PARTNERS/WELCHALLYN.htm>;

Welch Allyn Expands Patient Monitor Capabilities with Masimo Pulse Oximetry Technology, printed on Aug. 20, 2009.

<http://www.masimo.com/pulseOximeter/PP0.htm>; Masimo Personal Pulse Oximeter, printed on Aug. 20, 2009.

<http://www.masimo.com/generalFloor/system.htm>; Masimo Patient SafetyNet System at a Glance, printed on Aug. 20, 2009.

<http://www.masimo.com/partners/GRASEBY.htm>; Graseby Medical Limited, printed on Aug. 20, 2009.

Japanese Office Action, re JP Application No. 2011-516895, mailed Sep. 2, 2014, with translation.

European Office Action issued in application No. 10763901.5 on Jan. 11, 2013.

European Office Action issued in application No. 10763901.5 on Aug. 27, 2014.

European Office Action issued in application No. 10763901.5 on Aug. 6, 2015.

Kanukurthy et al., "Data Acquisition Unit for an Implantable Multi-Channel Optical Glucose Sensor", Electro/Information Technology Conference, Chicago, IL, USA, May 17-20, 2007, pp. 1-6.

Smith, "The Pursuit of Noninvasive Glucose: 'Hunting the Deceitful Turkey'", 2006.

Small et al., "Data Handling Issues for Near-Infrared Glucose Measurements", <http://www.ieee.org/organizations/pubs/newsletters/leos/apr98/datahandling.htm>, accessed Nov. 27, 2007.

* cited by examiner

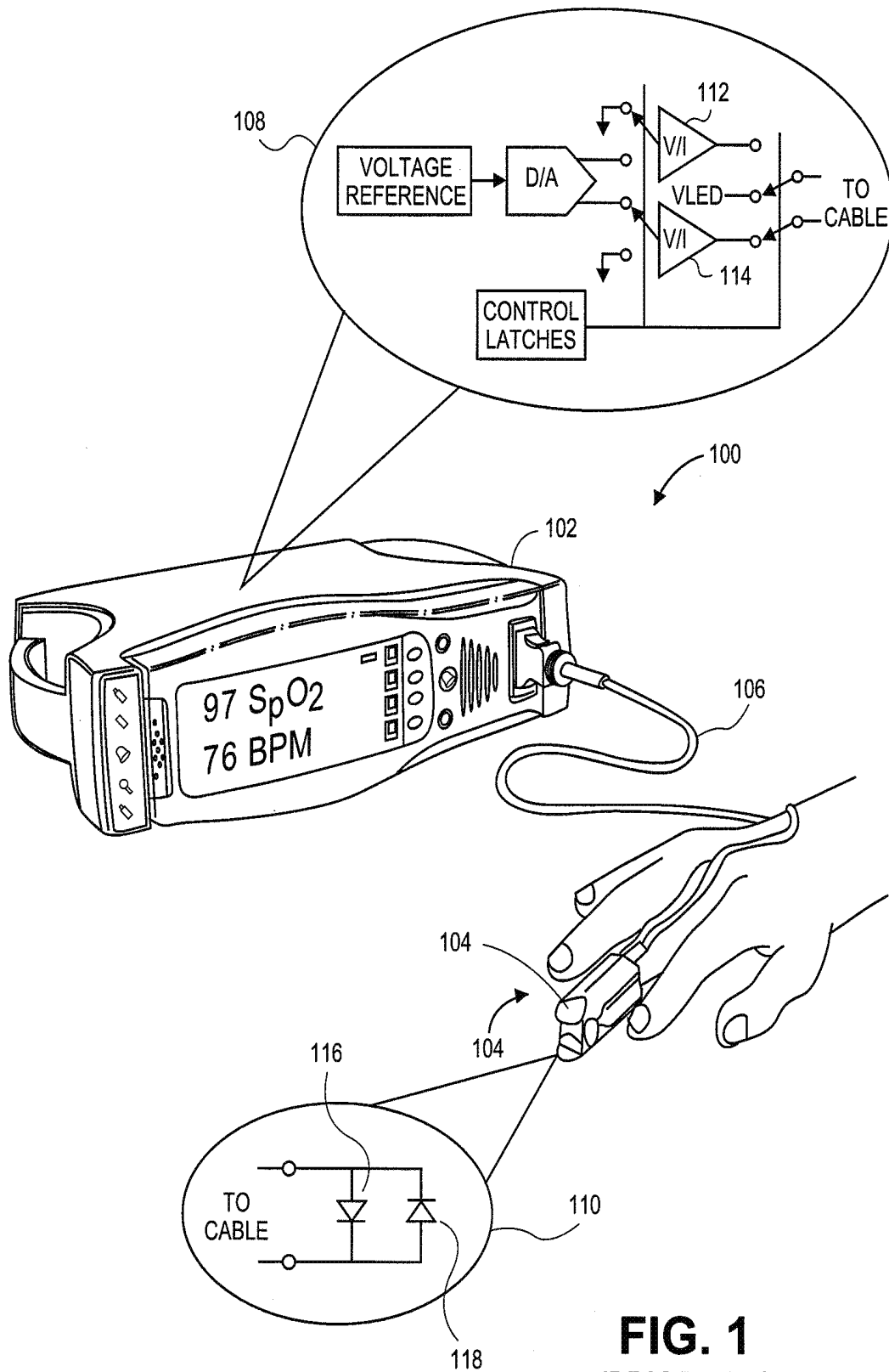

FIG. 1
(PRIOR ART)

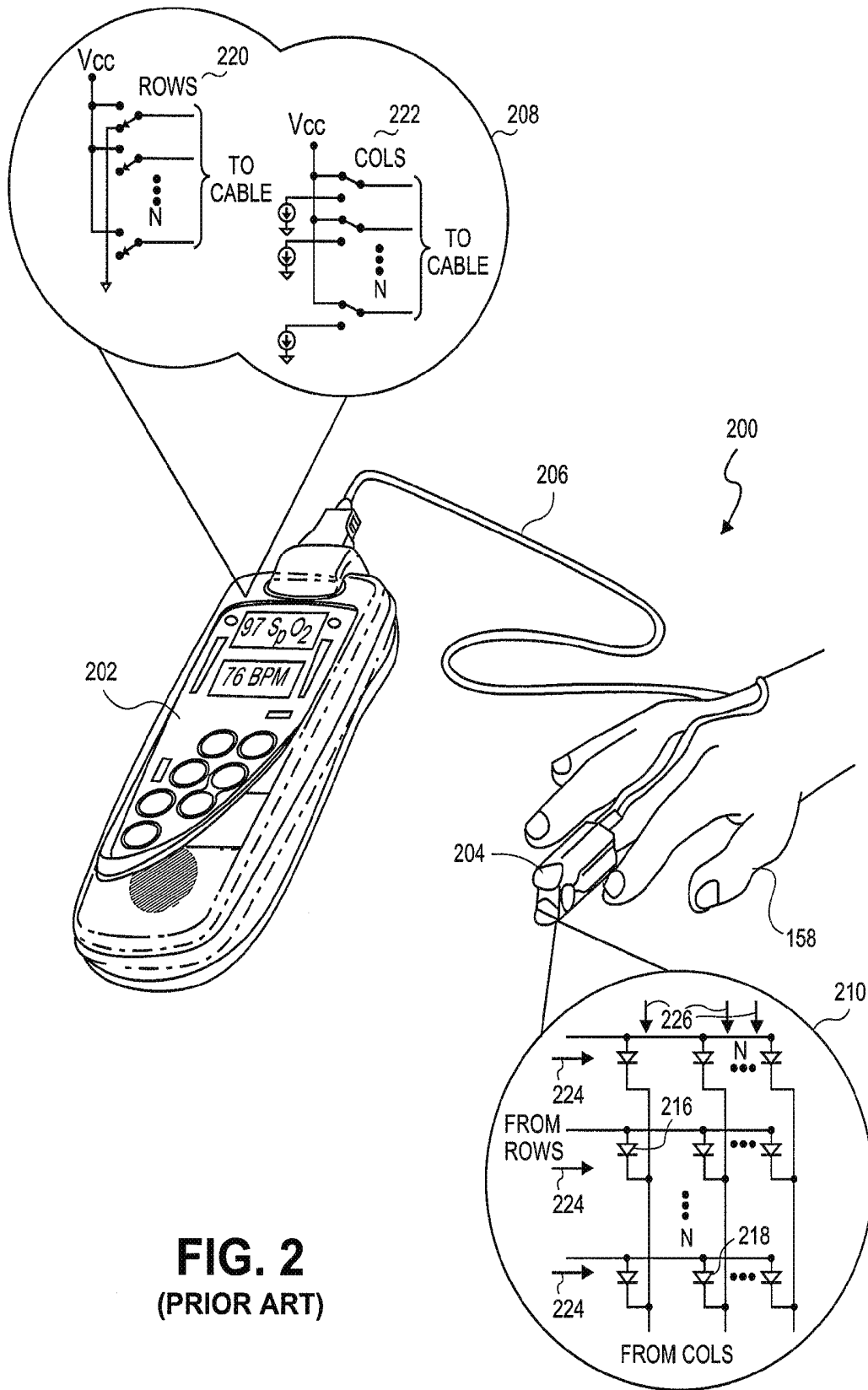

FIG. 2
(PRIOR ART)

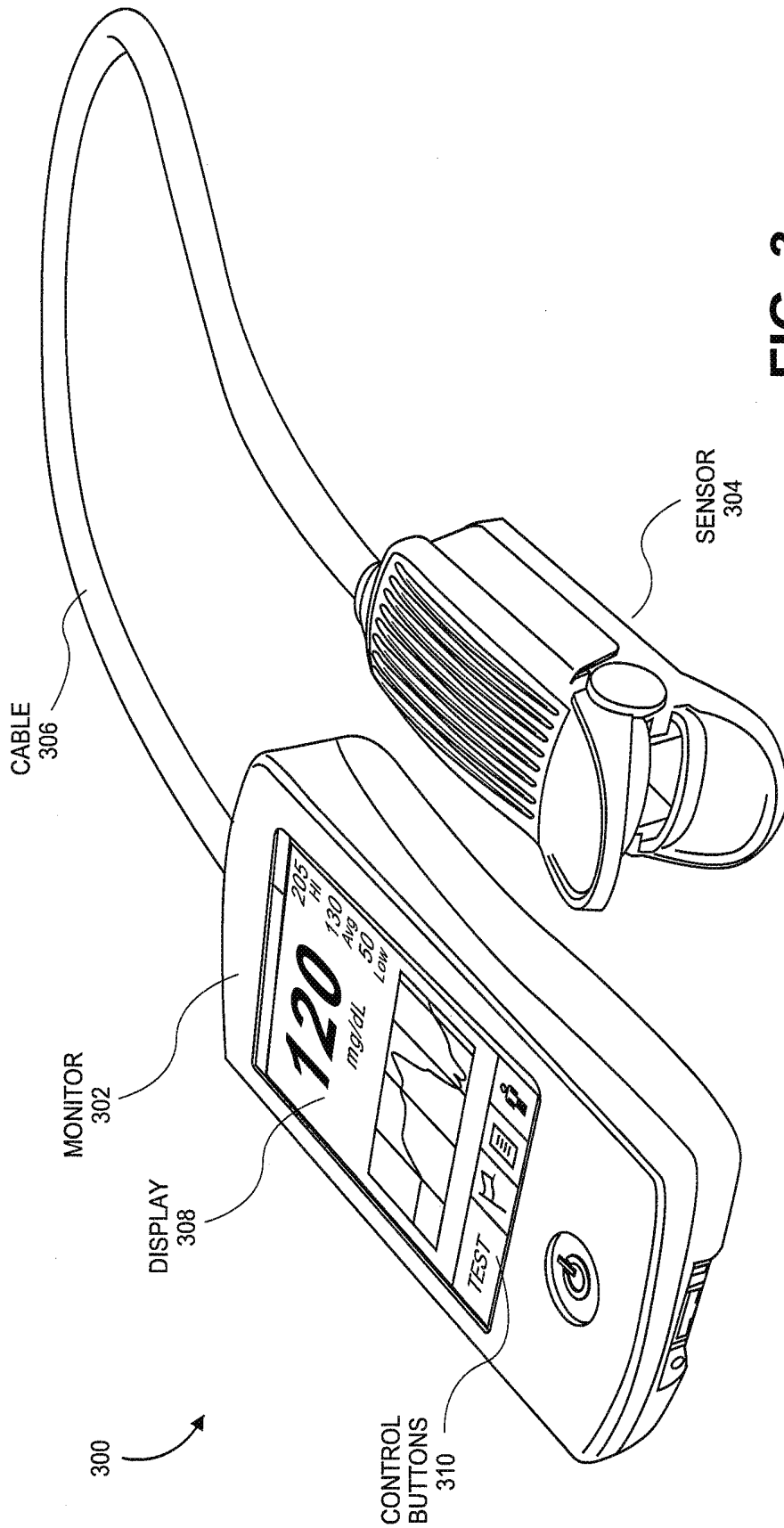

FIG. 3

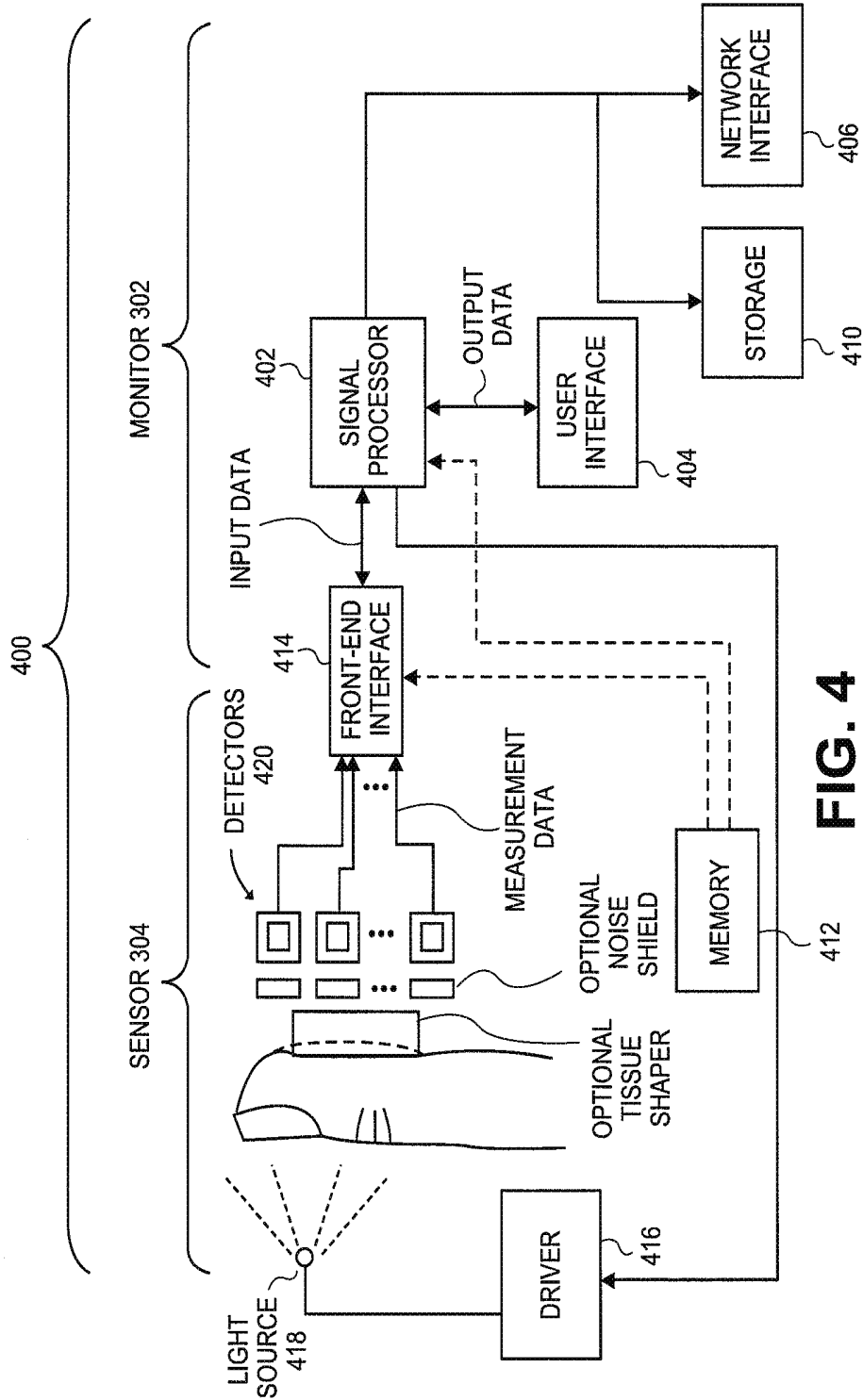

FIG. 4

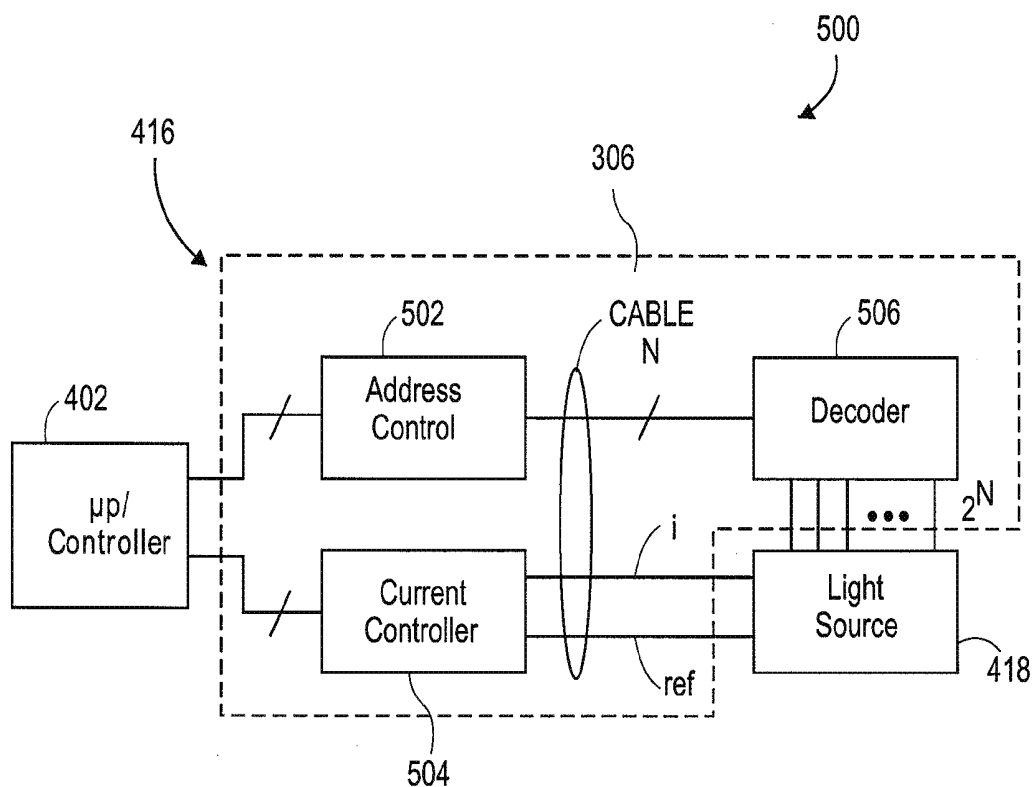

FIG. 5

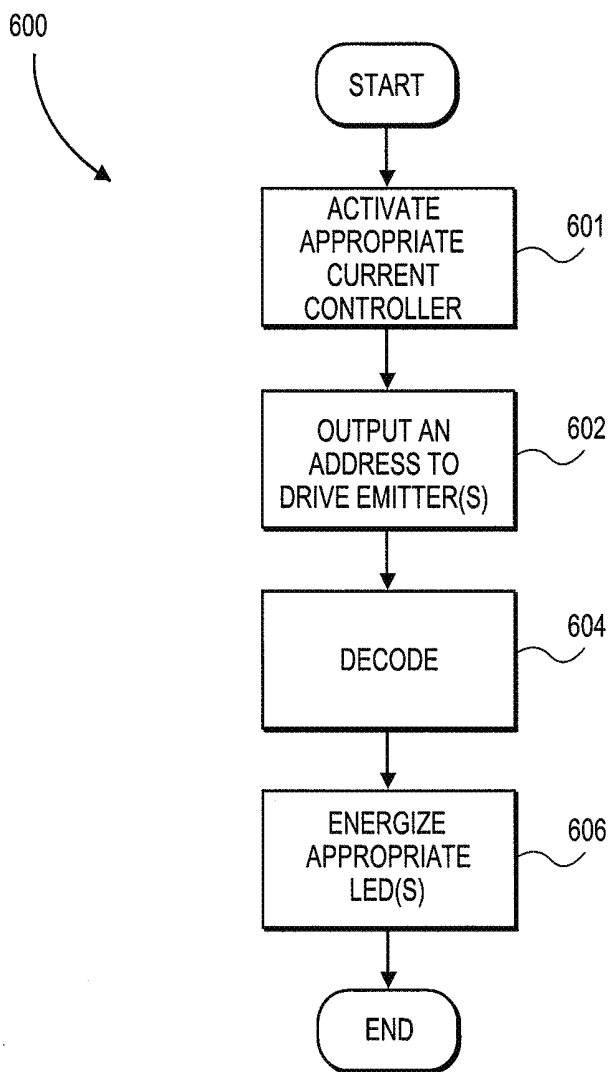

FIG. 6

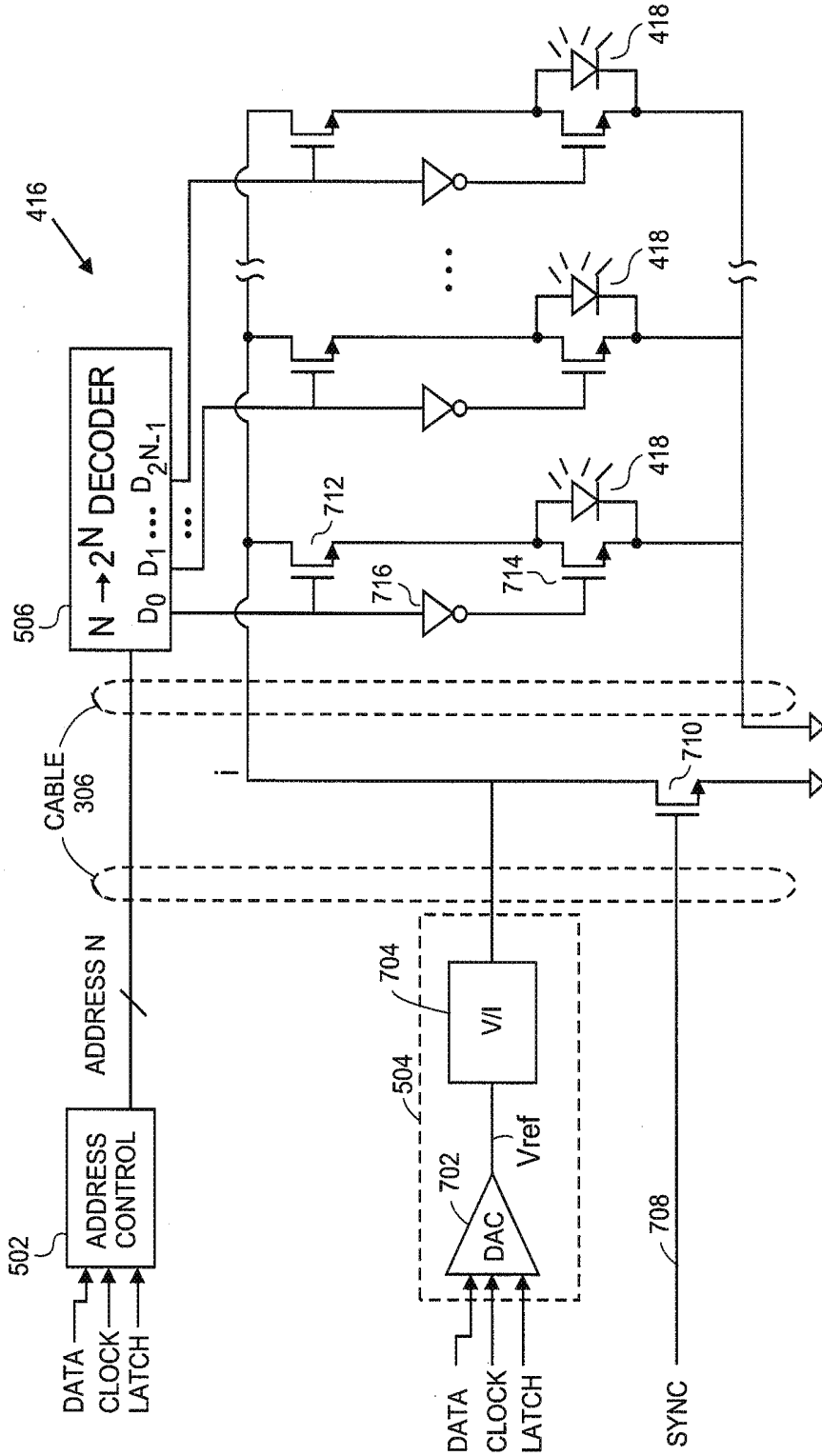

FIG. 7A

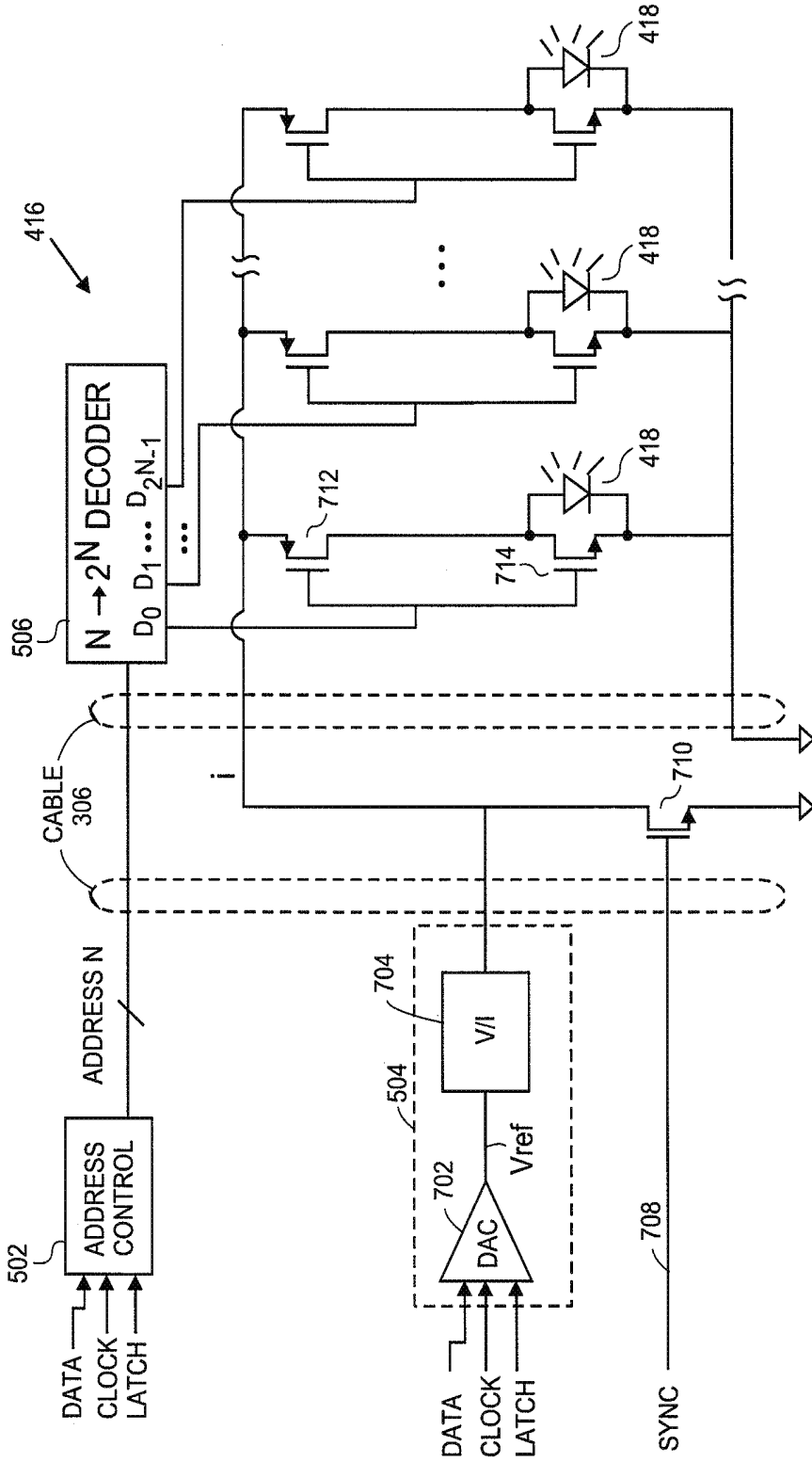

FIG. 7B

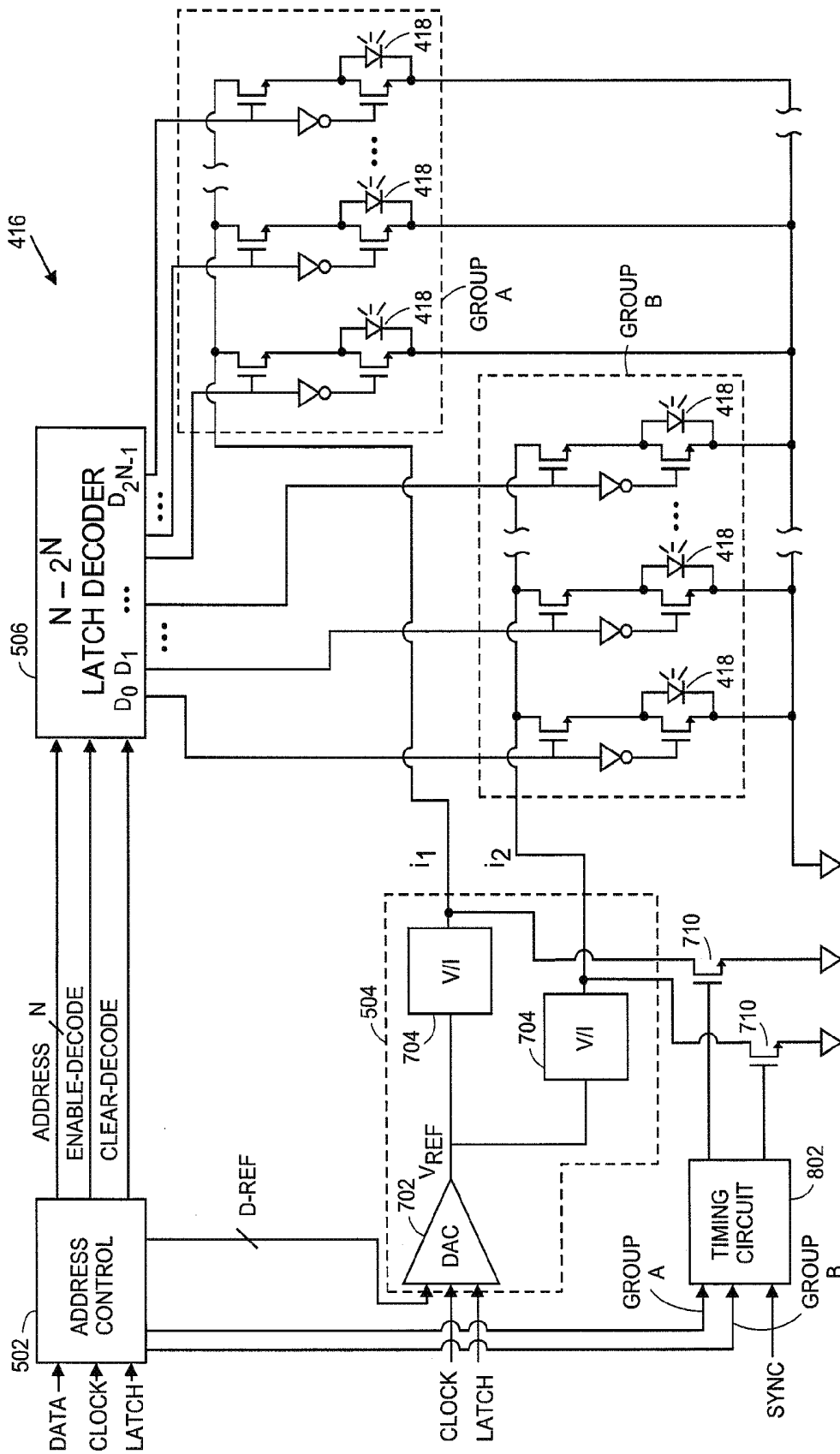

FIG. 8

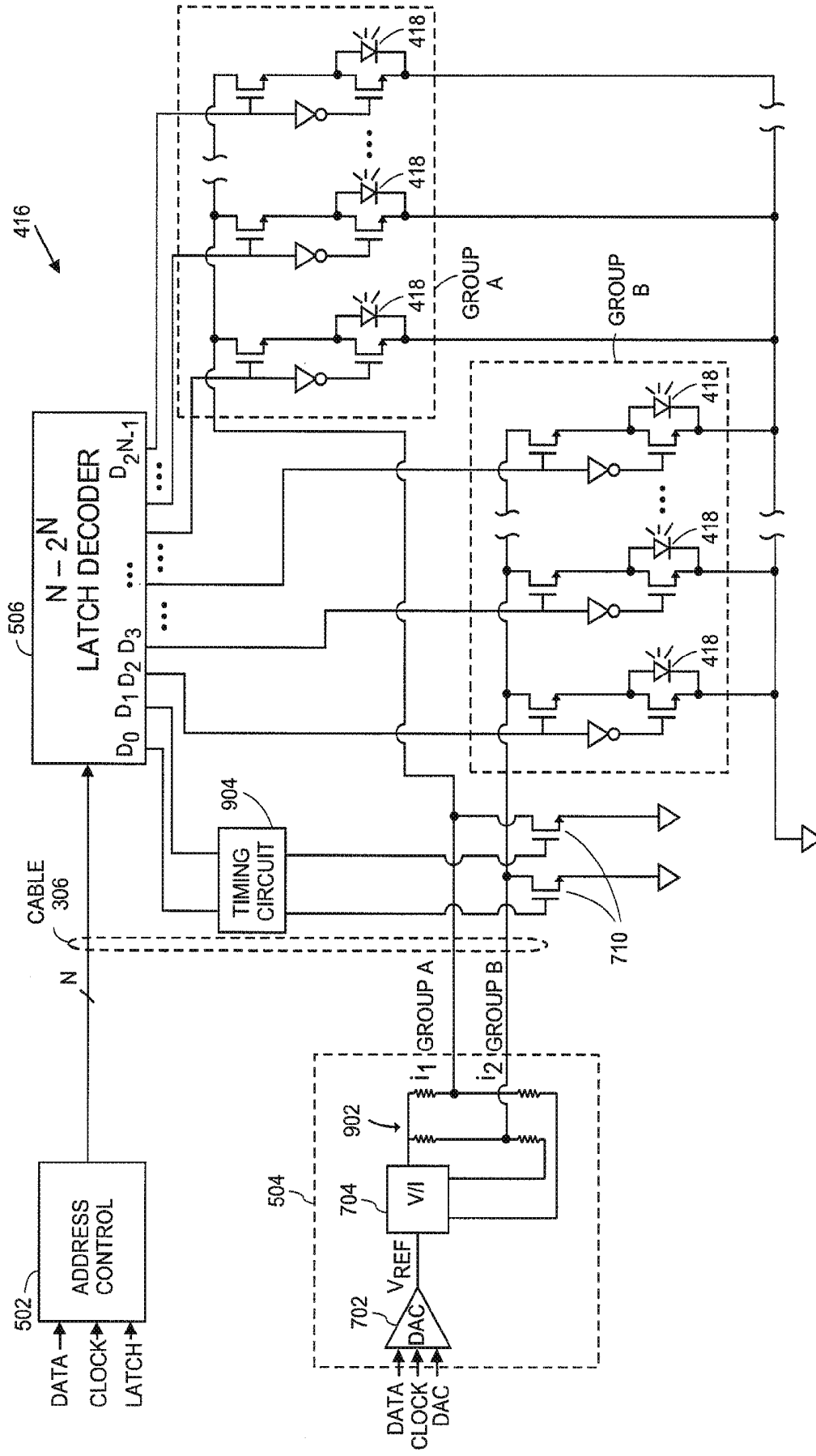

FIG. 9

EMITTER DRIVER FOR NONINVASIVE PATIENT MONITOR

REFERENCE TO RELATED APPLICATIONS

The present application is a continuation of U.S. patent application Ser. No. 14/227,230, filed Mar. 27, 2014, entitled "Emitter Driver for Noninvasive Patient Monitor," which is a continuation of U.S. patent application Ser. No. 12/875,062, filed Sep. 2, 2010, entitled "Emitter Driver for Noninvasive Patient Monitor," which claims priority benefit under 35 U.S.C. §119(e) from U.S. Provisional Application No. 61/239,741, filed Sep. 3, 2009, entitled "Emitter Driver for Noninvasive Patient Monitor;" the disclosures of which are incorporated herein by reference.

The present disclosure is also related to the following applications.

App. No.	Filing Date	Title	Attorney Docket
12/534,827	Aug. 3, 2009	<i>Multi-Stream Data Collection System for Noninvasive Measurement of Blood Constituents</i>	MASCER.002A
12/534,812	Aug. 3, 2009	<i>Multi-Stream Sensor Front Ends for Noninvasive Measurement of Blood Constituents</i>	MASCER.003A
12/534,823	Aug. 3, 2009	<i>Multi-Stream Sensor for Noninvasive Measurement of Blood Constituents</i>	MASCER.004A
12/534,825	Aug. 3, 2009	<i>Multi-Stream Emitter for Noninvasive Measurement of Blood Constituents</i>	CERCA.005A
12/497,528	Jul. 2, 2009	<i>Noise Shielding for a Noninvasive Device</i>	MASCER.006A
12/497,523	Jul. 2, 2009	<i>Contoured Protrusion for Improving Spectroscopic Measurement of Blood Constituents</i>	MASCER.007A
29/323,409	Aug. 25, 2008	<i>Patient Monitoring Sensor</i>	MASCER.009DA
29/323,408	Aug. 25, 2008	<i>Patient Monitor</i>	MASCER.010DA
12/497,506	Jul. 2, 2009	<i>Heat Sink for Noninvasive Medical Sensor</i>	MASCER.011A

Each of the foregoing is incorporated by reference herein in its entirety.

BACKGROUND OF THE INVENTION

Field of the Invention

The present disclosure generally relates to patient monitoring devices and more specifically, embodiments of the present disclosure relate to driving light sources of patient monitoring devices to properly irradiate tissue under observation.

Description of the Related Art

Spectroscopic patient monitoring systems including noninvasive patient monitoring systems often energize a plurality of emission devices that irradiate tissue under observation. In many systems, the emission devices irradiate the tissue at different wavelengths at different times. The radiation is scattered and absorbed by the tissue such that some attenuated amount thereof emerges and is generally detected through one or more photodetectors. The photodetectors

output one or more signals indicative of the intensity of the detected attenuated radiation and forward the signal to a patient monitor for processing.

In many systems, the patient monitor provides a drive signal configured to activate each emission device at a different time over an activation cycle, thereby reducing a likelihood that a detector seeking a measure of attenuation in light of one wavelength will be effected by radiation from light of another wavelength.

For example, FIG. 1 illustrates a patient monitoring system **100** including a patient monitor **102** communicating with a noninvasive optical sensor **104** through cable **106**. As shown in FIG. 1, the monitor **102** displays calculated measurements derived at least in part from processing an output signal from the sensor **104** indicative of light attenuated by pulsing blood. As shown in FIG. 1, the monitor **102** includes a driving circuit **108** configured to drive a sensor light source **110**, such as, for example, a two emitter light source configured to emit light at different wavelengths. The emitters shown in FIG. 1 are connected in parallel in a back-to-back configuration, although other configurations and their drive circuitry requirements will be recognizable to an artisan from the disclosure herein, including, for example, common anode, common cathode and the like.

In general, a processor of said monitor **102** controls various latching mechanisms to activate one of voltage-to-current converters **112**, **114** at a time. Once activated, the converters **112**, **114** provide a current through conductors of the cable **106** to an associated LED **116**, **118** of the sensor **104**. Thus, the processor may output appropriate latching signals to the driving circuit **108** to precisely control a duty cycle and current level for each of the LEDs **116**, **118**, and ensure that the LEDs **116**, **118** are activated one at a time. Examples of the driver circuitry of FIG. 1 are disclosed in U.S. Pat. No. 6,157,850. The '850 patent disclosure is incorporated in its entirety by reference herein.

In contrast to the driving circuit **108** and light source **110** of FIG. 1, FIG. 2 illustrates a patient monitoring system **200** including a patient monitor **202** communicating with a noninvasive optical sensor **204** through a cable **206**. As shown in FIG. 2, the monitor **202** displays calculated measurements derived at least in part from processing an output signal from the sensor **204** indicative of light attenuated by pulsing blood. As shown in FIG. 2, the monitor **202** includes a driving circuit **208** configured to drive a sensor light source **210**, such as, a grid array of LEDs capable of emitting light at different wavelengths of radiation.

In general, the driving circuit **208** includes a plurality of row drivers **220** and a plurality of column drivers **222**, the activation of a particular row driver and a particular column driver corresponds to the activation of one or a group of LEDs arranged at a corresponding node in a grid of rows **224** and columns **226**. Such activation is controlled through one or more processors of said monitor **202** in order to precisely control a duty cycle for each of the LEDs in the grid array, including LEDs **216**, **218**. For example, row and column drivers **220**, **222** function together as switches to Vcc and current sinks, respectively, to activate LEDs and function as switches to ground and Vcc, respectively, to deactivate LEDs. This push-pull drive configuration advantageously prevents parasitic current flow, and thus, parasitic activation, in deactivated LEDs. In a particular embodiment, one row drive line **224** is switched to Vcc at a time. Examples of the driver circuitry of FIG. 2 are disclosed in U.S. Pat. App. Pub.

No. 2006/0241363. The '363 patent application's disclosure is incorporated by reference in its entirety herein.

SUMMARY OF THE INVENTION

The foregoing LED driver circuits **108**, **208** include some limitations. The driver circuit **108** uses a separate drive conductor for each LED of the light source **110**. Thus, in the system **100** of FIG. 1, the cable **106** carries N drive currents over N conductors to drive N LEDs. As will be recognizable to an artisan from the disclosure herein, increasing a number LEDs in the light source **110** to, for example, increase a number of available wavelengths, corresponds to increasing a number of conductors in the cable **106**. Each increase of conductors carrying high emitter driver currents in the cable increases a likelihood of interference with other conductors of cable **106**, such as those conductors communicating sensitive very low currents or voltages at high impedance as output signals from the detectors of the sensor **104**. Moreover, each increase of conductors increases cable size, cost, complexity, shielding, cable stiffness, and the like, thereby decreasing patient comfort.

Driver circuit **208**, including the row and column drivers **220**, **222**, is an improvement to the N-to-N driver circuit **108** of FIG. 1. For example, in the system **200** of FIG. 2, the cable **206** carries N high emitter driver currents on N conductors. Half of the N conductors correspond to high current row drive signals and half correspond to high current column drive signals. These N conductors allow a processor to address and thus activate specific nodes of a light source grid array of 2^N nodes. Similar to the N-to-N driver circuit **108**, an artisan will recognize from the disclosure herein, that increasing a number LEDs in the light source grid array **210** to, for example, increase a number of available wavelengths, corresponds to increasing a number of conductors in the cable **206**, thereby potentially increasing a likelihood of harmful interference in detector signals.

Based on at least the foregoing, when a need exists to increase a number of different wavelength LEDs to accommodate more sophisticated signal processing of patient monitors, a need exists to find better solutions for driving light sources. Often, increasing available wavelengths corresponds to seeking to measure physiological parameters that are more difficult to distinguish from surrounding noise, including, for example, total hemoglobin monitors, glucose monitors, methemoglobin monitors, combinations of the same or the like, or corresponds to increasing the sensitivity in conventional pulse oximeters. However, simply increasing a number of high current conductors in a given cable **106**, **206** can be fraught with drawbacks including cable stiffness and crosstalk noise on detector conductors.

Accordingly, embodiments of the present disclosure include a patient monitoring system where a patient monitor employs addressing schemes to increase a number of specifically selectable activation nodes of a light source. In an embodiment, an emitter driver is configured to address substantially 2^N nodes, where N is a number cable conductors configured to carry activation instructions from a processor. In an embodiment, an address controller outputs an activation instruction to a latch decoder configured to supply switch controls to logic devices governing the activations of LEDs of a light source. In an embodiment, N cable conductors can be used to uniquely address all or substantially all of 2^N LED nodes. In certain embodiments, the activation instruction need not be a high current signal. For example, in some of the presently disclosed embodiments, a cable carries one or a few high current emitter driver signals,

which can be routed through logic and addressing to a desired node of the light source. For example, in an embodiment where each LED of a light source can be driven with the same or similar current, embodiments of the cable of the present disclosure may carry a single high current conductor. In embodiments where LEDs of a light source may use different currents to drive different types of LEDs, such as, for example, light sources including superluminescent, laser or side emitting LEDs, along with more traditional LEDs, embodiments of the cable of the present disclosure may carry currents appropriate for each type of LED over a plurality of high current conductors. In many embodiments, however, the number of high current conductors is dramatically reduced from that of the drivers disclosed in the Background herein.

Embodiments of the present disclosure include a non-invasive physiological sensor configured to output one or more signals indicative of one or more physiological conditions of a patient being monitored. The sensor includes a plurality of light emitting sources configured for transmitting optical radiation to a measurement site. The sensor also includes one or more detectors configured to output said one or more signals responsive to said optical radiation detected after attenuation by body tissue of said patient at said measurement site. The one or more signals are indicative of said one or more physiological conditions of said patient. The sensor also includes a plurality of switches configured for selectively connecting one or more of the light emitting sources to one or more drive signals. Additionally, the sensor includes a decoder circuit configured for controlling the plurality of switches, wherein when said decoder circuit receives N inputs, said decoder circuit configured to selectively address up to 2^N unique locations. Each location includes one or more of said plurality of said semiconductor switches, wherein activation of one of said unique locations causes at least one of said light emitting sources to transmit said optical radiation to said measurement site.

Embodiments of the disclosure also include a cable communicating signals between a patient monitor and a noninvasive optical sensor. The cable comprises one or more signal lines configured to carry one or more drive signals configured to activate one or more light sources of said noninvasive optical sensor. The cable also includes N address lines capable of selecting 2^N unique locations and configured to selectively connect up to about 2^N light emitting sources to ones of said one or more drive signals. The connection activating said light emitting sources to provide light to tissue of a patient wearing said sensor and allowing one or more photodetectors to detect light from said activated sources after attenuation by tissue from said patient.

In still other embodiments, the disclosure includes a method to selectively drive light emitting sources in a noninvasive optical physiological sensor for monitoring parameters of a patient. The method includes attaching said sensor to a patient where said sensor includes at least one different semiconductor switch in series with each of the light emitting sources. The method also including activating said semiconductor switches to connect associated light emitting sources to a drive signal. The light emitting source transmits optical radiation into a measurement site of said patient, and said activation comprises providing N conductors to a decoder capable of controlling about 2^N of the semiconductor switches and configured to control up to about 2^N of the semiconductor switches.

For purposes of summarizing the invention, certain aspects, advantages and novel features of the invention have been described herein. Of course, it is to be understood that

not necessarily all such aspects, advantages or features will be embodied in any particular embodiment of the invention.

BRIEF DESCRIPTION OF THE DRAWINGS

The following drawings and the associated descriptions are provided to illustrate embodiments of the present disclosure and do not limit the scope of the claims.

FIG. 1 illustrates a traditional patient monitoring system including a patient monitor communicating with a noninvasive optical sensor through a cable.

FIG. 2 illustrates another traditional patient monitoring system including a patient monitor communicating with a noninvasive optical sensor through a cable.

FIG. 3 illustrates a patient monitoring system according to

embodiments of the present disclosure.

FIG. 4 illustrates an exemplary block diagram of embodiments of the system of FIG. 3.

FIG. 5 illustrates an exemplary block diagram of embodiments of a driver of FIG. 4.

FIG. 6 illustrates an exemplary flowchart of a driving process according to embodiments of the present disclosure.

FIGS. 7A-7B illustrates exemplary block diagrams of alternative embodiments of the driver of FIG. 4, where FIG. 7A illustrates a first method of shorting unused LEDs and

FIG. 7B illustrates a second method of shorting unused LEDs.

FIG. 8 illustrates another exemplary block diagram of an embodiment of the driver of FIG. 4 configured to drive LEDs with different drive current requirements.

FIG. 9 illustrates another exemplary block diagram of an embodiment of the driver of FIG. 4 configured to drive LEDs while avoiding a SYNC signal through a patient cable.

DETAILED DESCRIPTION OF THE PREFERRED EMBODIMENT

Embodiments of the present disclosure include a patient monitoring system including a patient monitor having a driving circuit advantageously capable of selectively activating 2^N LEDs of a light source using a decoder receiving an N signal address. In various disclosed embodiments, use of addressing and a decoder advantageously reduces a number of high current conductors in a cable communicating signals between the monitor and, for example, a noninvasive sensor. For example, in embodiments where a light source includes LEDs configured to be driven by a single current, embodiments of the present disclosure provide that the cable may carry a single high current conductor. In other embodiments where the light source includes LEDs configured to be driven at a first current and additional LEDs configured to be driven at a second current different from the first, embodiments of the present disclosure provide that the cable may carry the plurality of high current conductors, one for each current required. While some embodiments shown herein require two currents, an artisan will recognize from the disclosure herein how to add additional currents when LED configurations so require.

In the foregoing embodiments, the driver circuit advantageously includes use of addressing and a decoder, the addressing information carried over conductors carrying lower, less interfering signals than those of driving currents. Accordingly, embodiments of the present disclosure reduce the potential of harmful crosstalk between high current conductors carrying driver signals and low current conductors carrying, for example, sensitive detector signals. Moreover, cables associated with the present disclosure may

advantageously require fewer larger heavily shielded driver conductors, and therefore, may be less costly to produce, be less rigid or stiff and thus more ergonomic to a wearer of a sensor.

In additional embodiments, each LED is shorted by a transistor that is conducting unless that particular LED is activated. Such shorting advantageously reduces the likelihood of unwanted emissions by LEDs emitting unwanted wavelengths due to, for example, parasitic currents. Also, various embodiments include on/off timing hardware configured to govern the shorting transistors to improve timing of LED activations and deactivations.

To facilitate a complete understanding of the invention, the remainder of the detailed description references to the drawings, wherein like reference numbers are referenced with like numerals throughout.

FIG. 3 illustrates a patient monitoring system 300 according to embodiments of the present disclosure. As shown in FIG. 3, the system 300 includes a patient monitor 302, a noninvasive sensor 304 communicating with the monitor 302 through a cable 306. The monitor 302 drives a lights source including a plurality of emitters of the sensor 304 to irradiate tissue of a wearer of the sensor 304. The sensor 304 also includes one or more photodetectors that detect light attenuated by the body tissue and output one or more signals indicative of the detected light. The monitor 302 receives the one or more output signals of the sensor 304, processes the signals and determines one or more measurement values of various physiological characteristics of the wearer. The monitor 302 includes a display 308 configured to provide alphanumeric and/or graphical information to a caregiver. The monitor 302 also includes a plurality of user input devices 310 including for example, a touch screen and one or more input keys. An artisan will recognize from the disclosure herein that the input devices 310 could comprise one or a combination of control buttons, dials, knobs, or the like, touch screen inputs, vocal commands, or the like.

Although disclosed as a portable handheld device, an artisan will recognize from the disclosure herein that the monitor 302 may comprise a desktop or stationary monitor, may monitor some or many parameters, may output information to legacy caregiver systems, may wirelessly communicate between sensors and monitors, between monitors and other monitors, combinations of the same and the like.

FIG. 4 illustrates an exemplary block diagram 400 of embodiments of the monitor 302 of the system of FIG. 3. As shown in FIG. 4, the monitor 302 may include one or more signal processors 402 communicating with a user interface 404, network interface 406, memory and storage 410, sensor and/or cable memory 412, a front end interface 414 and driver circuitry 416. In general, the processor 402 outputs control data to the driver circuitry 416, which in turn selectively activates LEDs of a light source 418 to irradiate tissue, such as, for example a digit of the wearer. The tissue absorbs the irradiation and one or more detectors 420 detect the attenuated light. The detectors output one or more signals indicative of the attenuated light to the front end interface 414, which filters and pre-process the output signal. Signal processor 402 receives the processed and filtered output signal and determines measurement values for the one or more monitored parameters.

In various embodiments, the sensor 304 may include a tissue shaper configured to mechanically stabilize and/or control the shape of the digit at the measurement site. In an embodiment, the tissue shaper may advantageously include a bump including a substantially cylindrical surface. Additional embodiments of the tissue shaper are disclosed in U.S.

patent application Ser. No. 12/534,827, filed on Aug. 3, 2009. The teachings of the '827 application relating to the tissue shaper are incorporated by reference in its entirety herein. Additionally, advantages are found in the spatial arrangement of the detectors, the number of detectors **420** and in noise shielding structures of the sensor **304**. Disclosures pertaining thereto can also be found in the '827 application, and those disclosures are also incorporated by reference in their entirety herein.

In addition to the foregoing, the processor **402** is also configured to execute measurement determination software instructions that use received detector signal data pre-processed by the front end **414** to determine output measurement values for one or more parameters of the tissue. Exemplary algorithms for determining measurement values can be found in U.S. Pat. No. 6,157,850, U.S. patent application Ser. No. 12/534,827, filed on Aug. 3, 2009 and Ser. No. 11/366,209, filed on Mar. 1, 2006. The disclosure relating to determination of measurements from input sensor data is incorporated from each of the foregoing documents in its entirety by reference herein.

FIG. 5 illustrates an exemplary block diagram **500** of embodiments of the driver **416** of FIG. 4. As shown in FIG. 5, the processor **402** communicates with an address control **502** and one or more driving current controllers **504** to precisely control activation of the light source **418**. In an embodiment, the address control **502** outputs an address, such as, for example, a binary number, to a decoder **506**. The decoder **506** decodes the address and identifies particular LED(s) of the light source **418** to be connected to the current source **504**. Once connected, current flows through the particular LED, thereby activating it to irradiate tissue. In an embodiment, the decoder comprises an N-to- 2^N decoder, which an artisan will recognize from the disclosure herein to include its broad ordinary meaning, including a decoder that accepts an address word, such as, for example, a binary set of N bits, and associates that word with a particular LED node. For example, a 4 bit word uniquely identifies 16 possible LEDs. However, extension of just an additional 4 bits to an 8 bit word uniquely identifies up to 256 possible LEDs or LED locations. Examples of the decoder **506** are commercially available from vendors such as Fairchild Semiconductor, Texas Instruments, NXP Semiconductors, or the like.

In an embodiment, the current controller **504** may comprise logic allowing the processor **402** the ability to select from a plurality of differing currents levels. For example, when the light source **418** comprises, for example, LED devices and more powerful superluminescent, laser or side emitting LEDs, the driver **416** adjusts the current controller **504** to provide the appropriate current to the appropriate LED at the appropriate address. For example, the current controller **504** may advantageously select an appropriate one of a plurality of currents depending on a type of LED addressed by the processor **402** through the address decoder **506**.

In an embodiment, the current controller **504** seeks to keep current patterns similar regardless of whether LEDs are activated or not. In embodiments having a plurality of different currents, twisting the conductors on which the currents travel in opposite direction to the input data wires in the cable **306** has been shown to reduce effects of crosstalk on other conductors in the cable **306**.

FIG. 5 also shows that the address control **502** and current controller **504** may advantageously be housed in the monitor **302**, although an artisan will recognize from the disclosure herein that one or more of the controls **502**, **504** could reside

anywhere along the path from the monitor **302** to the sensor **304**, including the various connectors of the monitor **302**, the cable **306** and the sensor **304**. As shown in FIG. 5, the cable **306** includes conductors for the N address lines, the current sources, ground, shield, and other needs, such as, for example, conductors communicating with a thermister, one or more memories, or other desired sensor devices.

FIG. 6 illustrates an exemplary flowchart of a driving process **600** according to an embodiment of the present disclosure. In block **601**, the processor **402** activates the current controller to output an appropriate current. In an embodiment of multiple current sources, the activation includes a selection of an appropriate current, as will be discussed further with respect to FIGS. 8 and 9. In block **602**, the processor **402** outputs an address of a particular LED to be activated. In block **604**, the N-to- 2^N decoder **506** receives the address and determines the unique output to be activated. In an embodiment, the determination includes translation of a binary or other word to activation of logic transistors configured to connect a particular LED to the current source and in some embodiments, disconnect a short around the same LED. In block **606**, the decoder **506** activates the appropriate logic devices to connect the appropriate LED to the appropriate current controller **504** for the duration of the determined duty cycle. In an embodiment, the address control **502** comprises latches set by the processor **402** in order to control for each LED the on and off timing. In an embodiment, one node is energized at a time, and in further embodiments, some time spacing or gap is provided between consecutive activations to guard against interference at the detector by light of differing wavelengths. In an embodiment, the gap, or no LED activation occurs between activations of LEDs. In an embodiment, the gap comprises one of the 2^N addressable locations such that an all-off condition is specifically addressable by the processor **402**. In an embodiment, the addressable all-off condition may comprise multiple addresses, one for each current level available from the current controller **504**.

Although disclosed with reference to process **600**, an artisan will recognize from the disclosure herein that other processes may be used to selectively address an activation location or group of activation locations of a light source and supply the location or group of activation locations with the appropriate amount of current.

FIGS. 7A and 7B illustrate exemplary block diagrams of embodiments of the driver **416** driving the light source **418** of FIG. 4, where the driver **416** includes a single current controller. As shown in FIGS. 7A and 7B, the driver **416** includes the address control **502**, the current controller **504**, and the decoder **506**. In an embodiment, the current controller **504** includes a converter **702** converting digital signals from the processor into analog output. In an embodiment, the DAC **702** controls light saturation by allowing for the fine tuning of the output drive current. The DAC **702** receives clock and data signals from the processor and a latching signal dictating when the DAC should lock the data on the data signal and stabilize the output drive current.

The output of the DAC **702** is provided to amplifier **704** which in an embodiment includes a precision voltage-to-current amplifier that adjusts its output current based on the input voltage. The output of the amplifier **704** is also provided as the driving current to the LEDs of the light source **418**, in an embodiment, through the cable **306**. A SYNC signal **708** is provided to ensure precision on/off timing to the LED addressed by the decoder **506**. Imperfections in the circuitry and parasitic parameters may cause the rise and fall times for the current i to be less precise than

desired. The SYNC signal **708** can advantageously be timed to sink to ground some or all of the imperfections and parasitic parameters that occur during rising or falling current through the LED **418** through a logic switching device **710**. Sinking these imperfections advantageously produces a higher quality current, which produces better on/off activation of the light source **418**, which provides for a better signal to noise ratio. In an embodiment, the sync signal **708** is combined to create a single output current i . In an embodiment, the output current may comprise about 0-about 80 mA, controlled at least in part by the voltage provided by the processor **402** to the DAC **702**.

As shown in FIGS. **7A** and **7B**, control logic ensures that each LED of the light source **418** can activate only when its location is decoded by the decoder **506**. For example, when a particular location is inactive, a first logic device **712** is biased open such that current cannot flow through it. A second logic device **714** is biased closed to create a short around the LED at the inactive location; the short is also connected to ground. Thus, were any parasitic current to appear on the drive conductor for the particular location, it will be simply shorted to ground and cannot cause the LED to emit radiation. When the decoder **506** receives the address of the particular location, the first logic device **712** is biased closed and the second logic device **714** is biased open. The closing of device **712** connects the second logic device and the LED of the particular location to the current i of the current controller **504**. The opening of device **714** removes the short around the LED, which is now connected to the drive current i , and the LED activates to emit light at its designated wavelength.

In the embodiment shown in FIG. **7A**, an inverter **716** is placed at one the gates of the logic devices **712** and **714**, causing them to oppose one another. For example, a single control signal from the decoder **504** is supplied to the gate of device **712** causing it to open or close, and its opposite is supplied to the gate of device **714** causing it to respectively close or open. In the embodiment shown in FIG. **7B**, devices **712** and **714** are opposite devices such that a same signal from the decoder **504** applied to both gates causes one of the devices **712** to open and close while the other **714** respectively closes and opens.

An artisan will recognize from the disclosure herein other logic devices and schemes to assist in precisely governing the on/off cycles of each LED of the light source **418** while simultaneously precisely governing the drive current to the same.

As can also be seen in FIGS. **7A** and **7B**, the cable **306** carries conductors for the output of the current controller **504** and the address control. In alternative embodiments, the cable **306** may also carry the SYNC signal. Thus, in various embodiments, the cable **306** may advantageously include a single high current signal, N address signals and still be able to uniquely activate substantially 2^N light source nodes. In an embodiment, "substantially" may be defined to be when one or more of the 2^N light source nodes correspond to a null set where no nodes are active. The null set is advantageously to ensure spacing between LED activations.

FIG. **8** illustrates another exemplary block diagram of embodiments of the driver **416** driving the light source **418** of FIG. **4**, where the driver **416** comprises a plurality of current controllers **504**. As shown in FIG. **8**, the current controller **504** outputs two different currents i_1 and i_2 set by the voltage output by the converter **702** governed by the processor **402**. FIG. **8** further shows output current i_1 communicating with the nodes of a first group of LEDs, Group A, and the output current i_2 communicating with the

nodes of a second group of LEDs, Group B. In an embodiment, i_1 may comprise about 0-about 80 mA, while i_2 may comprise about 0-about 800 mA. An artisan will recognize that other embodiments may advantageously employ other currents and/or have more or less groups.

Thus, in an embodiment where some of the LEDs of the light source **418** comprise LEDs driven at greater power; those LEDs may advantageously communicate with the output of the current source i_2 . Also shown in FIG. **8** is timing circuit **802** including logic configured to provide appropriate SYNC signals to logic devices **710** for sinking each of currents i_1 and i_2 similar to that disclosed with reference to FIGS. **7A** and **7B**.

In an embodiment, the amplifier **704** comprises a plurality of amplifiers and resistors in a feedback configuration to provide a stabilized current based on an input voltage. Such configurations are known to an artisan from the disclosure herein. In an embodiment, the timing circuit **802** comprises logic combinations of signals to ensure only one of the currents i_1 and i_2 can flow to ground at a time. In an embodiment, the SYNC signal is logic ANDed with each of the Group A, Group B signals such that the SYNC and Group A signals must match to open a first logic switch device **710** and allow current i_1 to flow, and SYNC and Group B signals must match to open a second logic switch device **710** and allow current i_2 to flow.

FIG. **9** illustrates another exemplary block diagram of embodiments of the driver **416** driving the light source **418** of FIG. **4**, where the driver **416** comprises a plurality of current controllers **504**. However, in FIG. **9**, the current controller **504** outputs two different currents i_1 and i_2 using a single amplifier **704** and analog circuitry **902** that produces the currents i_1 and i_2 for Group A and Group B LEDs. Moreover, FIG. **9** illustrates the SYNC signal functionality and the signal itself as part of the sensor **104**. For example, in this embodiment, two locations or addresses available on the decoder **505** correspond to the SYNC signals of FIG. **8**, such that the processor **402** produces the SYNC signals not as processor outputs, but as addresses of the controller **504**. Timing circuit **904** includes logic to ensure only one of the currents i_1 and i_2 can flow to ground at a time by controlling logic device **710** now on the sensor **304**. Thus, in the embodiment of FIG. **9**, the processor **402** advantageously replaces output signals with addressing. The advantages of this embodiment include the sinking of parasitic currents and imperfections on the LED driver **416** itself, and particularly on the sensor **304**, which is downstream from the cable **306**. In some cases, the cable **306** produces many of the parasitic currents and imperfections due to resistance, inductance and capacitance (or the like) associated with the conductors and conductive materials of the cable **306**. Sinking these harmful effects downstream on the sensor ensures that they do not effect the operation of the LEDs **418**.

Although the driver circuitry is disclosed with reference to its preferred and alternative embodiments, the disclosure is not intended to be limited thereby. Rather, a skilled artisan will recognize from the disclosure herein a wide number of alternatives for driver, including, for example, employing an amplifier/DAC for each group of current controllers to increase performance thereof. Also, the artisan will recognize from the disclosure herein that the address control, the decoder, and the current controllers can individually be placed anywhere along the monitoring path. For example, the components can be housed in the monitor **302**, in the sensor **304**, or in the cable **306** or connectors associated with any of the foregoing.

Additionally, other combinations, omissions, substitutions and modifications will be apparent to the skilled artisan in view of the disclosure herein. Accordingly, the present invention is not intended to be limited by the reaction of the preferred embodiments, but is to be defined by reference to the appended claims.

Moreover, all publications, patents, and patent applications mentioned in this specification are herein incorporated by reference to the same extent as if each individual publication, patent, or patent application was specifically and individually indicated to be incorporated by reference.

What is claimed is:

1. A patient monitor configured to communicate with an optical sensor, the patient monitor comprising:

means for supplying a current to one or more optical radiation sources of an optical sensor;

means for determining an address of 2^N addresses to set a wavelength of optical radiation emitted by the one or more optical radiation sources to a desired wavelength, each of at least some of the 2^N addresses uniquely corresponding to a different wavelength of the optical radiation emitted by the one or more optical radiation sources, N being a number greater than 2; and

means for outputting the address as a set of N bits transmitted separately via N terminals.

2. The patient monitor of claim 1, wherein the means for supplying is configured to:

supply a first current level to the one or more optical radiation sources when the address is a first address; and

supply a second current level to the one or more optical radiation sources when the address is a second address different from the first address, the second current level being different from the first current level.

3. The patient monitor of claim 1, wherein the means for supplying is configured to:

supply a first current level to a first optical radiation source of the one or more optical radiation sources and not to a second optical radiation source of the one or more optical radiation sources; and

supply a second current level to the second optical radiation source and not to the first optical radiation source, the second current level being different from the first current level.

4. The patient monitor of claim 1, further comprising means for receiving a signal from the optical sensor in response to the means for outputting outputting the address, the signal being indicative of one or more physiological parameters of a patient.

5. The patient monitor of claim 4, further comprising means for determining a measurement value for the one or more physiological parameters based at least on the signal.

6. The patient monitor of claim 5, further comprising means for presenting the measurement value to a caregiver.

7. The patient monitor of claim 6, wherein the measurement value denotes a blood oxygen saturation level.

8. The patient monitor of claim 1, further comprising means for decoding the address and activating the one or more optical radiation sources according to a result of decoding the address.

9. The patient monitor of claim 1, wherein the means for supplying is configured to keep a pattern of the current supplied to the one or more optical radiation sources con-

sistent regardless of whether the optical radiation is being emitted by the one or more optical radiation sources.

10. The patient monitor of claim 1, wherein the means for supplying, the means for determining, and the means for outputting are positioned in a common housing.

11. The patient monitor of claim 1, further comprising means for providing a signal to control a precision of when the optical radiation is emitted by the one or more optical radiation sources.

12. The patient monitor of claim 1, in combination with the optical sensor, the one or more optical radiation sources comprising a plurality of light emitting diodes.

13. The patient monitor of claim 1, wherein N is 4.

14. The patient monitor of claim 1, wherein the means for supplying is configured to supply a current level ranging from 0 mA to 800 mA to the one or more optical radiation sources.

15. A patient monitor configured to communicate with an optical sensor, the patient monitor comprising:

a processor configured to select a desired wavelength of optical radiation emitted by one or more optical radiation sources of an optical sensor;

a current control circuit configured to supply a current to the one or more optical radiation sources; and

an address control circuit configured to set a wavelength of the optical radiation emitted by the one or more optical radiation sources to the desired wavelength by outputting an address as a set of N bits transmitted in parallel via N terminals, the address being selected from an address space comprising a plurality of addresses in which at least some of each of the plurality of addresses uniquely correspond to a different wavelength of the optical radiation emitted by the one or more optical radiation sources, N being a number greater than 2,

wherein a total number of addresses in the plurality of addresses is greater than $2N$ and less than or equal to 2^N .

16. The patient monitor of claim 15, wherein the current control circuit is configured to:

supply a first current level to the one or more optical radiation sources when the address is a first address;

supply a second current level to the one or more optical radiation sources when the address is a second address different from the first address, the second current level being different from the first current level.

17. The patient monitor of claim 15, wherein the processor is configured to receive a signal from the optical sensor in response to the address control circuit outputting the address, the signal being indicative of one or more physiological parameters of a patient.

18. The patient monitor of claim 17, wherein the processor is configured to:

determine a measurement value for the one or more physiological parameters based at least on the signal; and

output the measurement value for presentation to a caregiver.

19. The patient monitor of claim 18, wherein the measurement value denotes a blood oxygen saturation level.

20. The patient monitor of claim 15, wherein N is 4.

专利名称(译)	用于无创患者监护仪的发射器驱动器		
公开(公告)号	US9668680	公开(公告)日	2017-06-06
申请号	US14/942185	申请日	2015-11-16
[标]申请(专利权)人(译)	CERCACOR LAB		
申请(专利权)人(译)	CERCACOR LABORATORIES, INC.		
当前申请(专利权)人(译)	Masimo公司		
[标]发明人	BRUINSMA JOHANNES DALVI CRISTIANO LAMEGO MARCELO		
发明人	BRUINSMA, JOHANNES DALVI, CRISTIANO LAMEGO, MARCELO		
IPC分类号	A61B5/00 A61B5/1455		
CPC分类号	A61B5/14552 A61B5/0059 A61B5/6826 A61B2560/045 A61B2562/0233 A61B2562/046 A61B2562/222		
代理机构(译)	KNOBBE, MARTENS, 奥尔森 & BEAR LLP		
审查员(译)	PHAN, MINH		
优先权	12/875062 2014-04-01 US 61/239741 2009-09-03 US		
其他公开文献	US20160166188A1		
外部链接	Espacenet USPTO		

摘要(译)

本公开的实施例包括发射器驱动器，该发射器驱动器被配置为能够寻址具有N个电缆导体的基本上2N节点，N个电缆导体被配置为携带来自处理器的激活指令。在一个实施例中，地址控制器向锁存器解码器输出激活指令，锁存器解码器被配置为提供开关控制以激活光源的特定LED。

