



US009370335B2

(12) **United States Patent**
Al-Ali et al.

(10) **Patent No.:** **US 9,370,335 B2**
(45) **Date of Patent:** **Jun. 21, 2016**

(54) **PHYSIOLOGICAL ACOUSTIC MONITORING SYSTEM**

USPC 600/586
See application file for complete search history.

(71) Applicant: **MASIMO CORPORATION**, Irvine, CA (US)

(56) **References Cited**

(72) Inventors: **Ammar Al-Ali**, San Juan Capistrano, CA (US); **Sung Uk Lee**, Irvine, CA (US)

U.S. PATENT DOCUMENTS

(73) Assignee: **Masimo Corporation**, Irvine, CA (US)

3,682,161 A 8/1972 Aibert
3,951,230 A 4/1976 Littmann

(Continued)

(*) Notice: Subject to any disclaimer, the term of this patent is extended or adjusted under 35 U.S.C. 154(b) by 0 days.

FOREIGN PATENT DOCUMENTS

CA 2490438 4/2003
CA 2262236 4/2008

(Continued)

(21) Appl. No.: **14/522,474**

OTHER PUBLICATIONS

(22) Filed: **Oct. 23, 2014**

U.S. Appl. No. 12/905,384, filed Oct. 15, 2010, Al-Ali et al.

(65) **Prior Publication Data**

(Continued)

US 2015/0045685 A1 Feb. 12, 2015

Related U.S. Application Data

Primary Examiner — Max Hindenburg

(74) *Attorney, Agent, or Firm* — Knobbe Martens Olson & Bear, LLP

(63) Continuation of application No. 13/650,775, filed on Oct. 12, 2012, now Pat. No. 8,870,792, which is a continuation-in-part of application No. 12/905,036, filed on Oct. 14, 2010, now Pat. No. 8,821,415.

(57) **ABSTRACT**

(Continued)

A physiological acoustic monitoring system receives physiological data from an acoustic sensor, down-samples the data to generate raw audio of breathing sounds and compresses the raw audio. The acoustic monitoring system has an acoustic sensor signal responsive to tracheal sounds in a person. An A/D converter is responsive to the sensor signal so as to generate breathing sound data. A decimation filter and mixer down-samples the breathing sound data to raw audio data. A coder/compressor generates compressed audio data from the raw audio data. A decoder/decompressor decodes and decompresses the compressed audio data into decompressed audio data. The decompressed audio data is utilized to generate respiration-related parameters in real-time. The compressed audio data is stored and retrieved so as to generate respiration-related parameters in non-real-time. The real-time and non-real-time parameters are compared to verify matching results across multiple monitors.

(51) **Int. Cl.**
A61B 5/00 (2006.01)
A61B 7/00 (2006.01)
(Continued)

(52) **U.S. Cl.**
CPC **A61B 7/003** (2013.01); **A61B 5/082** (2013.01); **A61B 5/0803** (2013.01);
(Continued)

(58) **Field of Classification Search**
CPC A61B 5/08; A61B 7/00; A61B 7/003; A61B 2562/0204; A61B 5/0402; A61B 5/0803; A61B 5/0816; A61B 7/04

20 Claims, 11 Drawing Sheets

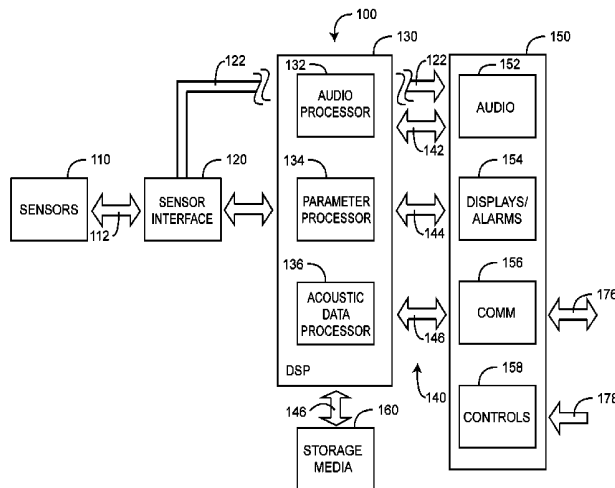

Related U.S. Application Data

- (60) Provisional application No. 61/547,007, filed on Oct. 13, 2011, provisional application No. 61/252,099, filed on Oct. 15, 2009, provisional application No. 61/391,098, filed on Oct. 8, 2010.
- (51) **Int. Cl.**
A61B 7/04 (2006.01)
A61B 5/08 (2006.01)
G10L 19/00 (2013.01)
- (52) **U.S. Cl.**
 CPC *A61B 5/0816* (2013.01); *A61B 5/0823* (2013.01); *A61B 5/725* (2013.01); *A61B 5/7225* (2013.01); *A61B 5/7278* (2013.01); *A61B 5/7405* (2013.01); *A61B 7/04* (2013.01); *G10L 19/00* (2013.01); *A61B 5/0004* (2013.01); *A61B 5/7232* (2013.01); *A61B 5/7415* (2013.01)

5,539,831	A	7/1996	Harley
5,561,275	A	10/1996	Savage et al.
5,562,002	A	10/1996	Lalin
5,564,108	A	10/1996	Hunsaker et al.
5,578,799	A	11/1996	Callahan et al.
5,590,649	A	1/1997	Caro et al.
5,602,924	A	2/1997	Durand et al.
5,632,272	A	5/1997	Diab et al.
5,638,816	A	6/1997	Kiani-Azarbayjany et al.
5,638,818	A	6/1997	Diab et al.
5,645,440	A	7/1997	Tobler et al.
5,685,299	A	11/1997	Diab et al.
D393,830	S	4/1998	Tobler et al.
5,738,106	A	4/1998	Yamamori et al.
5,743,262	A	4/1998	Lepper, Jr. et al.
5,758,644	A	6/1998	Diab et al.
5,760,910	A	6/1998	Lepper, Jr. et al.
5,769,785	A	6/1998	Diab et al.
5,782,757	A	7/1998	Diab et al.
5,785,659	A	7/1998	Caro et al.
5,791,347	A	8/1998	Flaherty et al.
5,810,734	A	9/1998	Caro et al.
5,812,678	A	9/1998	Scalise et al.
5,823,950	A	10/1998	Diab et al.
5,825,895	A	10/1998	Grasfield et al.
5,830,131	A	11/1998	Caro et al.
5,833,618	A	11/1998	Caro et al.
5,860,919	A	1/1999	Kiani-Azarbayjany et al.
5,890,929	A	4/1999	Mills et al.
5,904,654	A	5/1999	Wohltmann et al.
5,912,656	A	6/1999	Tham et al.
5,919,134	A	7/1999	Diab
5,934,925	A	8/1999	Tobler et al.
5,940,182	A	8/1999	Lepper, Jr. et al.
5,977,538	A	11/1999	Unger et al.
5,989,193	A	11/1999	Sullivan
5,995,855	A	11/1999	Kiani et al.
5,997,343	A	12/1999	Mills et al.
6,002,952	A	12/1999	Diab et al.
6,011,986	A	1/2000	Diab et al.
6,027,452	A	2/2000	Flaherty et al.
6,036,642	A	3/2000	Diab et al.
6,045,509	A	4/2000	Caro et al.
6,067,462	A	5/2000	Diab et al.
6,081,735	A	6/2000	Diab et al.
6,083,156	A	7/2000	Lisiecki
6,088,607	A	7/2000	Diab et al.
6,106,481	A	8/2000	Cohen
6,110,522	A	8/2000	Lepper, Jr. et al.
6,124,597	A	9/2000	Shehada
6,128,521	A	10/2000	Marro et al.
6,129,675	A	10/2000	Jay
6,144,868	A	11/2000	Parker
6,151,516	A	11/2000	Kiani-Azarbayjany et al.
6,152,754	A	11/2000	Gerhardt et al.
6,157,850	A	12/2000	Diab et al.
6,165,005	A	12/2000	Mills et al.
6,168,568	B1	1/2001	Gavriely
6,184,521	B1	2/2001	Coffin, IV et al.
6,206,830	B1	3/2001	Diab et al.
6,210,344	B1	4/2001	Perin et al.
6,229,856	B1	5/2001	Diab et al.
6,232,609	B1	5/2001	Snyder et al.
6,236,872	B1	5/2001	Diab et al.
6,241,683	B1	6/2001	Macklem et al.
6,248,083	B1	6/2001	Smith et al.
6,253,097	B1	6/2001	Aronow et al.
6,256,523	B1	7/2001	Diab et al.
6,261,237	B1	7/2001	Swanson et al.
6,263,222	B1	7/2001	Diab et al.
6,275,594	B1	8/2001	Senoo et al.
6,278,522	B1	8/2001	Lepper, Jr. et al.
6,280,213	B1	8/2001	Tobler et al.
6,285,896	B1	9/2001	Tobler et al.
6,295,365	B1	9/2001	Ota
6,301,493	B1	10/2001	Marro et al.
6,317,627	B1	11/2001	Ennen et al.
6,321,100	B1	11/2001	Parker
6,325,761	B1	12/2001	Jay

References Cited

U.S. PATENT DOCUMENTS

- 4,127,749 A 11/1978 Atoji et al.
 4,254,302 A 3/1981 Walshe
 4,326,143 A 4/1982 Guth et al.
 4,413,202 A 11/1983 Krempl et al.
 4,537,200 A 8/1985 Widrow
 4,576,179 A 3/1986 Manus et al.
 4,578,613 A 3/1986 Posthuma de Boer et al.
 4,634,917 A 1/1987 Dvorsky et al.
 4,672,976 A 6/1987 Kroll
 4,805,633 A 2/1989 Kotani et al.
 4,827,943 A 5/1989 Bornn et al.
 4,884,809 A 12/1989 Rowan
 4,924,876 A 5/1990 Cameron
 4,947,859 A 8/1990 Brewer et al.
 4,960,118 A 10/1990 Pennock
 4,960,128 A 10/1990 Gordon et al.
 4,964,408 A 10/1990 Hink et al.
 4,982,738 A 1/1991 Griebel
 5,003,605 A 3/1991 Phillipps et al.
 5,033,032 A 7/1991 Houghtaling
 5,036,857 A 8/1991 Semmlow et al.
 5,041,187 A 8/1991 Hink et al.
 5,069,213 A 12/1991 Polczynski
 5,078,151 A 1/1992 Laballery
 5,140,992 A 8/1992 Zuckerwar et al.
 5,143,078 A * 9/1992 Mather A61B 7/003
 600/484
- 5,163,438 A 11/1992 Gordon et al.
 5,269,314 A 12/1993 Kendall et al.
 5,278,627 A 1/1994 Aoyagi et al.
 5,319,355 A 6/1994 Russek
 5,337,744 A 8/1994 Branigan
 5,341,805 A 8/1994 Stavridi et al.
 D353,195 S 12/1994 Savage et al.
 D353,196 S 12/1994 Savage et al.
 5,377,676 A 1/1995 Vari et al.
 5,406,952 A 4/1995 Barnes et al.
 D359,546 S 6/1995 Savage et al.
 5,431,170 A 7/1995 Mathews
 D361,840 S 8/1995 Savage et al.
 D362,063 S 9/1995 Savage et al.
 5,448,996 A 9/1995 Bellin et al.
 5,452,717 A 9/1995 Branigan et al.
 D363,120 S 10/1995 Savage et al.
 5,456,252 A 10/1995 Vari et al.
 5,479,934 A 1/1996 Imran
 5,482,036 A 1/1996 Diab et al.
 5,490,505 A 2/1996 Diab et al.
 5,494,043 A 2/1996 O'Sullivan et al.
 5,533,511 A 7/1996 Kaspari et al.
 5,534,851 A 7/1996 Russek

(56)

References Cited

U.S. PATENT DOCUMENTS

6,334,065	B1	12/2001	Al-Ali et al.	6,931,268	B1	8/2005	Kiani-Azarbayjany et al.
6,343,224	B1	1/2002	Parker	6,934,570	B2	8/2005	Kiani et al.
6,349,228	B1	2/2002	Kiani et al.	6,937,736	B2	8/2005	Toda
6,360,114	B1	3/2002	Diab et al.	6,939,305	B2	9/2005	Flaherty et al.
6,368,283	B1	4/2002	Xu et al.	6,943,348	B1	9/2005	Coffin, IV
6,371,921	B1	4/2002	Caro et al.	6,950,687	B2	9/2005	Al-Ali
6,377,829	B1	4/2002	Al-Ali	6,954,971	B1	10/2005	Bryant et al.
6,388,240	B2	5/2002	Schulz et al.	6,961,598	B2	11/2005	Diab
6,397,091	B2	5/2002	Diab et al.	6,970,792	B1	11/2005	Diab
6,415,033	B1	7/2002	Halleck et al.	6,979,812	B2	12/2005	Al-Ali
6,423,013	B1	7/2002	Bakker et al.	6,985,764	B2	1/2006	Mason et al.
6,430,437	B1	8/2002	Marro	6,993,371	B2	1/2006	Kiani et al.
6,430,525	B1	8/2002	Weber et al.	6,996,427	B2	2/2006	Ali et al.
6,438,238	B1	8/2002	Callahan	6,999,904	B2	2/2006	Weber et al.
6,463,311	B1	10/2002	Diab	7,003,338	B2	2/2006	Weber et al.
6,470,199	B1	10/2002	Kopotic et al.	7,003,339	B2	2/2006	Diab et al.
6,486,588	B2	11/2002	Doron et al.	7,015,451	B2	3/2006	Dalke et al.
6,501,975	B2	12/2002	Diab et al.	7,024,233	B2	4/2006	Ali et al.
6,505,059	B1	1/2003	Kollias et al.	7,027,849	B2	4/2006	Al-Ali
6,515,273	B2	2/2003	Al-Ali	7,030,749	B2	4/2006	Al-Ali
6,517,497	B2	2/2003	Rymut et al.	7,035,684	B2	4/2006	Lee
6,519,487	B1	2/2003	Parker	7,039,449	B2	5/2006	Al-Ali
6,525,386	B1	2/2003	Mills et al.	7,041,060	B2	5/2006	Flaherty et al.
6,526,300	B1	2/2003	Kiani et al.	7,044,918	B2	5/2006	Diab
6,541,756	B2	4/2003	Schulz et al.	7,067,893	B2	6/2006	Mills et al.
6,542,764	B1	4/2003	Al-Ali et al.	7,096,052	B2	8/2006	Mason et al.
6,580,086	B1	6/2003	Schulz et al.	7,096,054	B2	8/2006	Abdul-Hafiz et al.
6,584,336	B1	6/2003	Ali et al.	7,096,060	B2	8/2006	Arand et al.
6,595,316	B2	7/2003	Cybulski et al.	7,110,804	B2	9/2006	Baumer et al.
6,597,932	B2	7/2003	Tian et al.	7,132,641	B2	11/2006	Schulz et al.
6,597,933	B2	7/2003	Kiani et al.	7,142,901	B2	11/2006	Kiani et al.
6,606,511	B1	8/2003	Ali et al.	7,149,561	B2	12/2006	Diab
6,632,181	B2	10/2003	Flaherty et al.	7,186,966	B2	3/2007	Al-Ali
6,639,668	B1	10/2003	Trepagnier	7,190,261	B2	3/2007	Al-Ali
6,640,116	B2	10/2003	Diab	7,215,984	B2	5/2007	Diab
6,643,530	B2	11/2003	Diab et al.	7,215,986	B2	5/2007	Diab
6,650,917	B2	11/2003	Diab et al.	7,221,971	B2	5/2007	Diab
6,654,624	B2	11/2003	Diab et al.	7,225,006	B2	5/2007	Al-Ali et al.
6,658,276	B2	12/2003	Pishney et al.	7,225,007	B2	5/2007	Al-Ali
6,661,161	B1	12/2003	Lanzo et al.	RE39,672	E	6/2007	Shehada et al.
6,671,531	B2	12/2003	Al-Ali et al.	7,239,905	B2	7/2007	Kiani-Azarbayjany et al.
6,678,543	B2	1/2004	Diab et al.	7,245,953	B1	7/2007	Parker
6,684,090	B2	1/2004	Ali et al.	7,246,069	B1	7/2007	O'Hanlon et al.
6,684,091	B2	1/2004	Parker	7,254,429	B2	8/2007	Schurman et al.
6,697,656	B1	2/2004	Al-Ali	7,254,431	B2	8/2007	Al-Ali
6,697,657	B1	2/2004	Shehada et al.	7,254,433	B2	8/2007	Diab et al.
6,697,658	B2	2/2004	Al-Ali	7,254,434	B2	8/2007	Schulz et al.
RE38,476	E	3/2004	Diab et al.	7,270,126	B2	9/2007	Wallace et al.
6,699,194	B1	3/2004	Diab et al.	7,272,425	B2	9/2007	Al-Ali
6,702,755	B1	3/2004	Stasz et al.	7,274,955	B2	9/2007	Kiani et al.
6,714,804	B2	3/2004	Al-Ali et al.	D554,263	S	10/2007	Al-Ali
RE38,492	E	4/2004	Diab et al.	7,280,858	B2	10/2007	Al-Ali et al.
6,721,582	B2	4/2004	Trepagnier et al.	7,289,835	B2	10/2007	Mansfield et al.
6,721,585	B1	4/2004	Parker	7,292,883	B2	11/2007	De Felice et al.
6,725,074	B1	4/2004	Kästle	7,295,866	B2	11/2007	Al-Ali
6,725,075	B2	4/2004	Al-Ali	7,328,053	B1	2/2008	Diab et al.
6,728,560	B2	4/2004	Kollias et al.	7,332,784	B2	2/2008	Mills et al.
6,735,459	B2	5/2004	Parker	7,340,287	B2	3/2008	Mason et al.
6,745,060	B2	6/2004	Diab et al.	7,341,559	B2	3/2008	Schulz et al.
6,760,607	B2	7/2004	Al-Ali	7,343,186	B2	3/2008	Lamego et al.
6,770,028	B1	8/2004	Ali et al.	D566,282	S	4/2008	Al-Ali et al.
6,771,994	B2	8/2004	Kiani et al.	7,355,512	B1	4/2008	Al-Ali
6,792,300	B1	9/2004	Diab et al.	7,356,365	B2	4/2008	Schurman
6,813,511	B2	11/2004	Diab et al.	7,361,148	B2	4/2008	Narimatsu
6,816,741	B2	11/2004	Diab	7,368,855	B2	5/2008	Orten
6,816,744	B2	11/2004	Garfield et al.	7,371,981	B2	5/2008	Abdul-Hafiz
6,822,564	B2	11/2004	Al-Ali	7,373,193	B2	5/2008	Al-Ali et al.
6,826,419	B2	11/2004	Diab et al.	7,373,194	B2	5/2008	Weber et al.
6,830,711	B2	12/2004	Mills et al.	7,376,453	B1	5/2008	Diab et al.
6,850,787	B2	2/2005	Weber et al.	7,377,794	B2	5/2008	Al-Ali et al.
6,850,788	B2	2/2005	Al-Ali	7,377,899	B2	5/2008	Weber et al.
6,852,083	B2	2/2005	Caro et al.	7,383,070	B2	6/2008	Diab et al.
6,861,639	B2	3/2005	Al-Ali	7,415,297	B2	8/2008	Al-Ali et al.
6,898,452	B2	5/2005	Al-Ali et al.	7,428,432	B2	9/2008	Ali et al.
6,920,345	B2	7/2005	Al-Ali et al.	7,438,683	B2	10/2008	Al-Ali et al.
				7,440,787	B2	10/2008	Diab
				7,454,240	B2	11/2008	Diab et al.
				7,467,002	B2	12/2008	Weber et al.
				7,469,157	B2	12/2008	Diab et al.

(56)

References Cited

U.S. PATENT DOCUMENTS

7,469,158	B2	12/2008	Cutler et al.	RE42,753	E	9/2011	Kiani-Azarbayjany et al.
7,471,969	B2	12/2008	Diab et al.	8,019,400	B2	9/2011	Diab et al.
7,471,971	B2	12/2008	Diab et al.	8,028,701	B2	10/2011	Al-Ali et al.
7,483,729	B2	1/2009	Al-Ali et al.	8,029,765	B2	10/2011	Bellott et al.
7,483,730	B2	1/2009	Diab et al.	8,036,727	B2	10/2011	Schurman et al.
7,489,958	B2	2/2009	Diab et al.	8,036,728	B2	10/2011	Diab et al.
7,496,391	B2	2/2009	Diab et al.	8,046,040	B2	10/2011	Ali et al.
7,496,393	B2	2/2009	Diab et al.	8,046,041	B2	10/2011	Diab et al.
D587,657	S	3/2009	Al-Ali et al.	8,046,042	B2	10/2011	Diab et al.
7,499,741	B2	3/2009	Diab et al.	8,048,040	B2	11/2011	Kiani
7,499,835	B2	3/2009	Weber et al.	8,050,728	B2	11/2011	Al-Ali et al.
7,500,950	B2	3/2009	Al-Ali et al.	8,092,396	B2	1/2012	Bagha et al.
7,509,154	B2	3/2009	Diab et al.	8,108,039	B2	1/2012	Saliga et al.
7,509,494	B2	3/2009	Al-Ali	RE43,169	E	2/2012	Parker
7,510,849	B2	3/2009	Schurman et al.	8,118,620	B2	2/2012	Al-Ali et al.
7,515,044	B2	4/2009	Welch et al.	8,121,673	B2	2/2012	Tran
7,526,328	B2	4/2009	Diab et al.	8,126,528	B2	2/2012	Diab et al.
7,530,942	B1	5/2009	Diab	8,128,572	B2	3/2012	Diab et al.
7,530,949	B2	5/2009	Al-Ali et al.	8,130,105	B2	3/2012	Al-Ali et al.
7,530,955	B2	5/2009	Diab et al.	8,145,287	B2	3/2012	Diab et al.
7,563,110	B2	7/2009	Al-Ali et al.	8,150,487	B2	4/2012	Diab et al.
7,596,398	B2	9/2009	Al-Ali et al.	8,175,672	B2	5/2012	Parker
7,618,375	B2	11/2009	Flaherty	8,180,420	B2	5/2012	Diab et al.
D606,659	S	12/2009	Kiani et al.	8,182,443	B1	5/2012	Kiani
7,647,083	B2	1/2010	Al-Ali et al.	8,185,180	B2	5/2012	Diab et al.
D609,193	S	2/2010	Al-Ali et al.	8,190,223	B2	5/2012	Al-Ali et al.
7,662,105	B2	2/2010	Hatlestad	8,190,227	B2	5/2012	Diab et al.
D614,305	S	4/2010	Al-Ali et al.	8,203,438	B2	6/2012	Kiani et al.
RE41,317	E	5/2010	Parker	8,203,704	B2	6/2012	Merritt et al.
7,729,733	B2	6/2010	Al-Ali et al.	8,204,566	B2	6/2012	Schurman et al.
7,734,320	B2	6/2010	Al-Ali	8,219,172	B2	7/2012	Schurman et al.
7,761,127	B2	7/2010	Al-Ali et al.	8,224,411	B2	7/2012	Al-Ali et al.
7,761,128	B2	7/2010	Al-Ali et al.	8,228,181	B2	7/2012	Al-Ali
7,764,982	B2	7/2010	Dalke et al.	8,229,533	B2	7/2012	Diab et al.
D621,516	S	8/2010	Kiani et al.	8,233,955	B2	7/2012	Al-Ali et al.
7,783,056	B2	8/2010	Wilmink	8,241,223	B2	8/2012	Gavriely et al.
7,791,155	B2	9/2010	Diab	8,244,325	B2	8/2012	Al-Ali et al.
7,801,581	B2	9/2010	Diab	8,255,026	B1	8/2012	Al-Ali
7,806,226	B2	10/2010	Drummond et al.	8,255,027	B2	8/2012	Al-Ali et al.
7,822,452	B2	10/2010	Schurman et al.	8,255,028	B2	8/2012	Al-Ali et al.
RE41,912	E	11/2010	Parker	8,260,577	B2	9/2012	Weber et al.
7,844,313	B2	11/2010	Kiani et al.	8,265,291	B2	9/2012	Bridger et al.
7,844,314	B2	11/2010	Al-Ali	8,265,723	B1	9/2012	McHale et al.
7,844,315	B2	11/2010	Al-Ali	8,274,360	B2	9/2012	Sampath et al.
7,860,553	B2	12/2010	Govari et al.	8,275,140	B2	9/2012	Smith
7,865,222	B2	1/2011	Weber et al.	8,301,217	B2	10/2012	Al-Ali et al.
7,873,497	B2	1/2011	Weber et al.	8,306,596	B2	11/2012	Schurman et al.
7,880,606	B2	2/2011	Al-Ali	8,310,336	B2	11/2012	Muhsin et al.
7,880,626	B2	2/2011	Al-Ali et al.	8,315,683	B2	11/2012	Al-Ali et al.
7,891,355	B2	2/2011	Al-Ali et al.	8,320,576	B1	11/2012	Abbruscato
7,894,868	B2	2/2011	Al-Ali et al.	RE43,860	E	12/2012	Parker
7,899,507	B2	3/2011	Al-Ali et al.	8,337,403	B2	12/2012	Al-Ali et al.
7,899,518	B2	3/2011	Trepagnier et al.	8,346,330	B2	1/2013	Lamego
7,904,132	B2	3/2011	Weber et al.	8,353,842	B2	1/2013	Al-Ali et al.
7,909,772	B2	3/2011	Popov et al.	8,355,766	B2	1/2013	MacNeish, III et al.
7,910,875	B2	3/2011	Al-Ali	8,359,080	B2	1/2013	Diab et al.
7,919,713	B2	4/2011	Al-Ali et al.	8,364,223	B2	1/2013	Al-Ali et al.
7,937,128	B2	5/2011	Al-Ali	8,364,226	B2	1/2013	Diab et al.
7,937,129	B2	5/2011	Mason et al.	8,374,665	B2	2/2013	Lamego
7,937,130	B2	5/2011	Diab et al.	8,385,995	B2	2/2013	Al-Ali et al.
7,940,937	B2	5/2011	Smith	8,385,996	B2	2/2013	Smith et al.
7,941,199	B2	5/2011	Kiani	8,388,353	B2	3/2013	Kiani et al.
7,951,086	B2	5/2011	Flaherty et al.	8,396,228	B2	3/2013	Bilan
7,957,780	B2	6/2011	Lamego et al.	8,399,822	B2	3/2013	Al-Ali
7,962,188	B2	6/2011	Kiani et al.	8,401,602	B2	3/2013	Kiani
7,962,190	B1	6/2011	Diab et al.	8,403,865	B2	3/2013	Halperin et al.
7,976,472	B2	7/2011	Kiani	8,405,608	B2	3/2013	Al-Ali et al.
7,976,480	B2	7/2011	Grajales et al.	8,414,499	B2	4/2013	Al-Ali et al.
7,988,637	B2	8/2011	Diab	8,418,524	B2	4/2013	Al-Ali
7,988,688	B2	8/2011	Webb et al.	8,423,106	B2	4/2013	Lamego et al.
7,990,382	B2	8/2011	Kiani	8,428,967	B2	4/2013	Olsen et al.
7,991,165	B2	8/2011	Kassal et al.	8,430,817	B1	4/2013	Al-Ali et al.
7,991,446	B2	8/2011	Ali et al.	8,437,825	B2	5/2013	Dalvi et al.
8,000,761	B2	8/2011	Al-Ali	8,449,469	B2	5/2013	Banet et al.
8,008,088	B2	8/2011	Bellott et al.	8,455,290	B2	6/2013	Siskavich
				8,457,703	B2	6/2013	Al-Ali
				8,457,707	B2	6/2013	Kiani
				8,463,349	B2	6/2013	Diab et al.
				8,466,286	B2	6/2013	Bellott et al.

(56)		References Cited			
		U.S. PATENT DOCUMENTS			
8,471,713	B2	6/2013	Poeze et al.	8,790,268	B2 7/2014 Al-Ali
8,473,020	B2	6/2013	Kiani et al.	8,801,613	B2 8/2014 Al-Ali et al.
8,483,787	B2	7/2013	Al-Ali et al.	8,821,397	B2 9/2014 Al-Ali et al.
8,489,364	B2	7/2013	Weber et al.	8,821,415	B2* 9/2014 Al-Ali A61B 7/003
8,491,489	B2	7/2013	Shin et al.		600/586
8,498,684	B2	7/2013	Weber et al.	8,830,449	B1 9/2014 Lamego et al.
8,504,128	B2	8/2013	Blank et al.	8,831,700	B2 9/2014 Schurman et al.
8,509,867	B2	8/2013	Workman et al.	8,840,549	B2 9/2014 Al-Ali et al.
8,515,509	B2	8/2013	Bruinsma et al.	8,847,740	B2 9/2014 Kiani et al.
8,517,981	B2	8/2013	Zornow	8,849,365	B2 9/2014 Smith et al.
8,523,781	B2	9/2013	Al-Ali	8,852,094	B2 10/2014 Al-Ali et al.
8,526,665	B2	9/2013	Lutz et al.	8,852,994	B2 10/2014 Wojtczuk et al.
8,529,301	B2	9/2013	Al-Ali et al.	8,868,147	B2 10/2014 Stippick et al.
8,532,727	B2	9/2013	Ali et al.	8,868,150	B2 10/2014 Al-Ali et al.
8,532,728	B2	9/2013	Diab et al.	8,870,792	B2* 10/2014 Al-Ali A61B 7/003
D692,145	S	10/2013	Al-Ali et al.		600/586
8,547,209	B2	10/2013	Kiani et al.	8,886,271	B2 11/2014 Kiani et al.
8,548,548	B2	10/2013	Al-Ali	8,888,539	B2 11/2014 Al-Ali et al.
8,548,549	B2	10/2013	Schurman et al.	8,888,708	B2 11/2014 Diab et al.
8,548,550	B2	10/2013	Al-Ali et al.	8,892,180	B2 11/2014 Weber et al.
8,560,032	B2	10/2013	Al-Ali et al.	8,897,847	B2 11/2014 Al-Ali
8,560,034	B1	10/2013	Diab et al.	8,909,310	B2 12/2014 Lamego et al.
8,570,167	B2	10/2013	Al-Ali	8,961,413	B2 2/2015 Teller et al.
8,570,503	B2	10/2013	Vo et al.	9,028,429	B2 5/2015 Telfort et al.
8,571,617	B2	10/2013	Reichgott et al.	9,037,207	B2 5/2015 Al-Ali et al.
8,571,618	B1	10/2013	Lamego et al.	9,060,721	B2 6/2015 Reichgott et al.
8,571,619	B2	10/2013	Al-Ali et al.	9,066,666	B2 6/2015 Kiani
8,577,431	B2	11/2013	Lamego et al.	9,066,680	B1 6/2015 Al-Ali et al.
8,581,732	B2	11/2013	Al-Ali et al.	9,072,474	B2 7/2015 Al-Ali et al.
8,584,345	B2	11/2013	Al-Ali et al.	9,078,560	B2 7/2015 Schurman et al.
8,588,880	B2	11/2013	Abdul-Hafiz et al.	9,084,569	B2 7/2015 Weber et al.
8,600,467	B2	12/2013	Al-Ali et al.	9,095,316	B2 8/2015 Welch et al.
8,606,342	B2	12/2013	Diab	9,106,038	B2 8/2015 Telfort et al.
8,626,255	B2	1/2014	Al-Ali et al.	9,107,625	B2 8/2015 Telfort et al.
8,630,691	B2	1/2014	Lamego et al.	9,107,626	B2 8/2015 Al-Ali et al.
8,634,889	B2	1/2014	Al-Ali et al.	9,113,831	B2 8/2015 Al-Ali
8,641,595	B2	2/2014	Basinger	9,113,832	B2 8/2015 Al-Ali
8,641,631	B2	2/2014	Sierra et al.	9,119,595	B2 9/2015 Lamego
8,652,060	B2	2/2014	Al-Ali	9,131,881	B2 9/2015 Diab et al.
8,663,107	B2	3/2014	Kiani	9,131,882	B2 9/2015 Al-Ali et al.
8,666,468	B1	3/2014	Al-Ali	9,131,883	B2 9/2015 Al-Ali
8,667,967	B2	3/2014	Al-Ali et al.	9,131,917	B2 9/2015 Telfort et al.
8,670,811	B2	3/2014	O'Reilly	9,138,180	B1 9/2015 Coverston et al.
8,670,814	B2	3/2014	Diab et al.	9,138,182	B2 9/2015 Al-Ali et al.
8,676,286	B2	3/2014	Weber et al.	9,138,192	B2 9/2015 Weber et al.
8,682,407	B2	3/2014	Al-Ali	9,142,117	B2 9/2015 Muhsin et al.
RE44,823	E	4/2014	Parker	9,153,112	B1 10/2015 Kiani et al.
RE44,875	E	4/2014	Kiani et al.	9,153,121	B2 10/2015 Kiani et al.
8,690,799	B2	4/2014	Telfort et al.	9,161,696	B2 10/2015 Al-Ali et al.
8,700,112	B2	4/2014	Kiani	9,161,713	B2 10/2015 Al-Ali et al.
8,702,627	B2	4/2014	Telfort et al.	9,167,995	B2 10/2015 Lamego et al.
8,706,179	B2	4/2014	Parker	9,176,141	B2 11/2015 Al-Ali et al.
8,712,494	B1	4/2014	MacNeish, III et al.	9,186,102	B2 11/2015 Bruinsma et al.
8,715,206	B2	5/2014	Telfort et al.	9,192,351	B1 11/2015 Telfort et al.
8,718,735	B2	5/2014	Lamego et al.	2002/0161291	A1 10/2002 Kiani et al.
8,718,737	B2	5/2014	Diab et al.	2002/0193670	A1 12/2002 Garfield et al.
8,718,738	B2	5/2014	Blank et al.	2003/0015368	A1 1/2003 Cybulski et al.
8,720,249	B2	5/2014	Al-Ali	2004/0133087	A1 7/2004 Ali et al.
8,721,541	B2	5/2014	Al-Ali et al.	2004/0158162	A1 8/2004 Narimatsu
8,721,542	B2	5/2014	Al-Ali et al.	2004/0167416	A1 8/2004 Lee
8,723,677	B1	5/2014	Kiani	2004/0215094	A1 10/2004 Baumer et al.
8,740,792	B1	6/2014	Kiani et al.	2004/0228494	A1 11/2004 Smith
8,754,776	B2	6/2014	Poeze et al.	2005/0033128	A1 2/2005 Ali
8,755,535	B2	6/2014	Telfort et al.	2005/0272987	A1 12/2005 Kiani-Azarbayjany et al.
8,755,856	B2	6/2014	Diab et al.	2005/0283059	A1 12/2005 Iyer et al.
8,755,872	B1	6/2014	Marinow	2006/0047215	A1 3/2006 Newman et al.
8,761,850	B2	6/2014	Lamego	2006/0094943	A1 5/2006 Van Slyke
8,764,671	B2	7/2014	Kiani	2006/0144397	A1 7/2006 Wallace et al.
8,768,423	B2	7/2014	Shakespeare et al.	2006/0184052	A1 8/2006 Iwasawa
8,771,204	B2	7/2014	Telfort et al.	2006/0198533	A1 9/2006 Wang
8,777,634	B2	7/2014	Kiani et al.	2006/0238333	A1 10/2006 Welch et al.
8,781,543	B2	7/2014	Diab et al.	2007/0049837	A1 3/2007 Shertukde et al.
8,781,544	B2	7/2014	Al-Ali et al.	2007/0058818	A1 3/2007 Yoshimine
8,781,549	B2	7/2014	Al-Ali et al.	2007/0106179	A1 5/2007 Bagha et al.
8,788,003	B2	7/2014	Schurman et al.	2007/0135725	A1 6/2007 Hatlestad
				2007/0147639	A1 6/2007 Richardson et al.
				2007/0165872	A1 7/2007 Bridger et al.
				2007/0167855	A1 7/2007 Shin et al.
				2007/0173730	A1 7/2007 Bikko

(56)

References Cited

U.S. PATENT DOCUMENTS

2007/0185397 A1	8/2007	Govari et al.	2013/0109935 A1	5/2013	Al-Ali et al.
2007/0282174 A1	12/2007	Sabatino	2013/0162433 A1	6/2013	Muhsin et al.
2007/0282212 A1	12/2007	Sierra et al.	2013/0178749 A1	7/2013	Lamego
2008/0039735 A1	2/2008	Hickerson	2013/0190581 A1	7/2013	Al-Ali et al.
2008/0076972 A1	3/2008	Dorogusker et al.	2013/0197328 A1	8/2013	Diab et al.
2008/0077026 A1	3/2008	Banet et al.	2013/0211214 A1	8/2013	Olsen
2008/0077198 A1	3/2008	Webb et al.	2013/0243021 A1	9/2013	Siskavich
2008/0077435 A1	3/2008	Muradia	2013/0253334 A1	9/2013	Al-Ali et al.
2008/0093157 A1	4/2008	Drummond et al.	2013/0274571 A1	10/2013	Diab et al.
2008/0097249 A1	4/2008	Pool et al.	2013/0296672 A1	11/2013	O'Neil et al.
2008/0137876 A1	6/2008	Kassal et al.	2013/0317327 A1	11/2013	Al-Ali et al.
2008/0188733 A1	8/2008	Al-Ali et al.	2013/0317370 A1	11/2013	Dalvi et al.
2008/0188760 A1	8/2008	Al-Ali	2013/0324808 A1	12/2013	Al-Ali et al.
2008/0219464 A1	9/2008	Smith	2013/0324817 A1	12/2013	Diab
2009/0018429 A1	1/2009	Saliga et al.	2013/0331670 A1	12/2013	Kiani
2009/0093687 A1	4/2009	Telfort et al.	2013/0338461 A1	12/2013	Lamego et al.
2009/0170664 A1	7/2009	Shirasaki et al.	2014/0012100 A1	1/2014	Al-Ali et al.
2009/0187065 A1	7/2009	Basinger	2014/0025306 A1	1/2014	Weber et al.
2009/0247924 A1	10/2009	Lamego et al.	2014/0034353 A1	2/2014	Al-Ali et al.
2009/0275844 A1	11/2009	Al-Ali	2014/0051952 A1	2/2014	Reichgott et al.
2009/0299157 A1	12/2009	Telfort et al.	2014/0051953 A1	2/2014	Lamego et al.
2009/0316925 A1	12/2009	Eisenfeld et al.	2014/0051954 A1	2/2014	Al-Ali et al.
2010/0004518 A1	1/2010	Vo et al.	2014/0058230 A1	2/2014	Abdul-Hafiz et al.
2010/0030040 A1	2/2010	Poeze et al.	2014/0066783 A1	3/2014	Kiani et al.
2010/0069725 A1	3/2010	Al-Ali	2014/0077956 A1	3/2014	Sampath et al.
2010/0090901 A1	4/2010	Smith et al.	2014/0081097 A1	3/2014	Al-Ali et al.
2010/0094096 A1	4/2010	Petruzzelli et al.	2014/0081100 A1	3/2014	Muhsin et al.
2010/0204996 A1	8/2010	Zeng et al.	2014/0081175 A1	3/2014	Telfort
2010/0261979 A1	10/2010	Kiani	2014/0094667 A1	4/2014	Schurman et al.
2010/0274099 A1	10/2010	Telfort et al.	2014/0100434 A1	4/2014	Diab et al.
2010/0317936 A1	12/2010	Al-Ali et al.	2014/0114199 A1	4/2014	Lamego et al.
2011/0001605 A1	1/2011	Kiani et al.	2014/0120564 A1	5/2014	Workman et al.
2011/0034831 A1	2/2011	Christensen et al.	2014/0121482 A1	5/2014	Merritt et al.
2011/0082711 A1	4/2011	Poeze et al.	2014/0121483 A1	5/2014	Kiani
2011/0105854 A1	5/2011	Kiani et al.	2014/0125495 A1	5/2014	Al-Ali
2011/0125060 A1	5/2011	Telfort et al.	2014/0127137 A1	5/2014	Bellott et al.
2011/0172551 A1	7/2011	Al-Ali	2014/0128696 A1	5/2014	Al-Ali
2011/0172561 A1	7/2011	Kiani et al.	2014/0128699 A1	5/2014	Al-Ali et al.
2011/0172967 A1	7/2011	Al-Ali et al.	2014/0129702 A1	5/2014	Lamego et al.
2011/0196211 A1	8/2011	Al-Ali et al.	2014/0135588 A1	5/2014	Al-Ali et al.
2011/0208015 A1	8/2011	Welch et al.	2014/0142399 A1	5/2014	Al-Ali et al.
2011/0209915 A1	9/2011	Telfort et al.	2014/0142401 A1	5/2014	Al-Ali et al.
2011/0213212 A1	9/2011	Al-Ali	2014/0142402 A1	5/2014	Al-Ali et al.
2011/0213271 A1	9/2011	Telfort et al.	2014/0163344 A1	6/2014	Al-Ali
2011/0213272 A1	9/2011	Telfort et al.	2014/0163402 A1	6/2014	Lamego et al.
2011/0213273 A1	9/2011	Telfort et al.	2014/0166076 A1	6/2014	Kiani et al.
2011/0213274 A1	9/2011	Telfort et al.	2014/0171763 A1	6/2014	Diab
2011/0224567 A1	9/2011	Al-Ali	2014/0180038 A1	6/2014	Kiani
2011/0230733 A1	9/2011	Al-Ali	2014/0180154 A1	6/2014	Sierra et al.
2011/0237911 A1	9/2011	Lamego et al.	2014/0194709 A1	7/2014	Al-Ali et al.
2011/0288431 A1	11/2011	Alshaer et al.	2014/0194711 A1	7/2014	Al-Ali
2012/0059267 A1	3/2012	Lamego et al.	2014/0194766 A1	7/2014	Al-Ali et al.
2012/0116175 A1	5/2012	Al-Ali et al.	2014/0200420 A1	7/2014	Al-Ali
2012/0179006 A1	7/2012	Jansen et al.	2014/0200422 A1	7/2014	Weber et al.
2012/0209082 A1	8/2012	Al-Ali	2014/0206963 A1	7/2014	Al-Ali
2012/0209084 A1	8/2012	Olsen et al.	2014/0213864 A1	7/2014	Abdul-Hafiz et al.
2012/0227739 A1	9/2012	Kiani	2014/0243627 A1	8/2014	Diab et al.
2012/0230523 A1	9/2012	Ehrlund	2014/0266790 A1	9/2014	Al-Ali et al.
2012/0232427 A1	9/2012	Bakema et al.	2014/0275808 A1	9/2014	Poeze et al.
2012/0265039 A1	10/2012	Kiani	2014/0275835 A1	9/2014	Lamego et al.
2012/0283524 A1	11/2012	Kiani et al.	2014/0275871 A1	9/2014	Lamego et al.
2012/0286955 A1	11/2012	Welch et al.	2014/0275872 A1	9/2014	Merritt et al.
2012/0296178 A1	11/2012	Lamego et al.	2014/0275881 A1	9/2014	Lamego et al.
2012/0302920 A1	11/2012	Bridger et al.	2014/0288400 A1	9/2014	Diab et al.
2012/0319816 A1	12/2012	Al-Ali	2014/0296664 A1	10/2014	Bruinsma et al.
2012/0330112 A1	12/2012	Lamego et al.	2014/0303520 A1	10/2014	Telfort et al.
2013/0023775 A1	1/2013	Lamego et al.	2014/0309506 A1	10/2014	Lamego et al.
2013/0041591 A1	2/2013	Lamego	2014/0309559 A1	10/2014	Telfort et al.
2013/0045685 A1	2/2013	Kiani	2014/0316228 A1	10/2014	Blank et al.
2013/0046204 A1	2/2013	Lamego et al.	2014/0323825 A1	10/2014	Al-Ali et al.
2013/0060108 A1	3/2013	Schurman et al.	2014/0330092 A1	11/2014	Al-Ali et al.
2013/0060147 A1	3/2013	Welch et al.	2014/0330098 A1	11/2014	Merritt et al.
2013/0079610 A1	3/2013	Al-Ali	2014/0330099 A1	11/2014	Al-Ali et al.
2013/0096405 A1	4/2013	Garfio	2014/0333440 A1	11/2014	Kiani
2013/0096936 A1	4/2013	Sampath et al.	2014/0336481 A1	11/2014	Shakespeare et al.
			2014/0343436 A1	11/2014	Kiani

(56)

References Cited

U.S. PATENT DOCUMENTS

2014/0371632 A1 12/2014 Al-Ali et al.
 2015/0025406 A1 1/2015 Al-Ali
 2015/0045685 A1 2/2015 Al-Ali et al.

FOREIGN PATENT DOCUMENTS

CN	201497610	6/2010
CN	202005761	10/2011
EP	0716628	12/1998
EP	0659058	1/1999
EP	0956820 A1	11/1999
EP	1207536	5/2002
EP	1518442	3/2005
EP	2 014 234	1/2009
EP	2391273	12/2011
EP	2488106	8/2012
EP	2488978	8/2012
EP	2710959	3/2014
FR	2 847 796	6/2004
GB	2358546	11/1999
JP	S56-031742 A	3/1961
JP	S53-094482 A	8/1978
JP	60059900	4/1985
JP	6214898	1/1987
JP	H04-317637 A	11/1992
JP	H07-152553 A	6/1995
JP	01-309872	6/1998
JP	10-155755	6/1998
JP	2001-50713	5/1999
JP	2003-329719	11/2003
JP	2005-522292 A	7/2005
JP	2005-531230 A	10/2005
JP	2012-513872	12/2009
JP	2013-508029	10/2010
JP	2013-508030	10/2010
NO	20040819	4/2003
WO	WO 94/05207	3/1994
WO	WO 94/13207	6/1994
WO	WO 95/29632	11/1995
WO	WO 99/53277	10/1999
WO	WO 00/10462	3/2000
WO	WO 01/34033	5/2001
WO	WO 01/78059	10/2001
WO	WO 01/87005	11/2001
WO	WO 01/97691	12/2001
WO	WO 02/03042	1/2002
WO	WO 02/24067	3/2002
WO	WO 03/058646	7/2003
WO	WO 03/087737	10/2003
WO	WO 04/000111	12/2003
WO	WO 2004/004411	1/2004
WO	WO 2005/096931	10/2005
WO	WO 2005/099562	10/2005
WO	WO 2008/017246	2/2008
WO	WO 2008/148172	12/2008
WO	WO 2009/137524	11/2009
WO	WO 2009/155593	12/2009
WO	WO 2010/078168	7/2010
WO	WO 2011/047207	4/2011
WO	WO 2011/047209	4/2011
WO	WO 2011/047213	4/2011
WO	WO 2011/047216	4/2011
WO	WO 2011/147211	4/2011
WO	WO 2013/056141	4/2013

OTHER PUBLICATIONS

U.S. Appl. No. 12/905,449, filed Oct. 15, 2010, Al-Ali et al.
 U.S. Appl. No. 12/905,489, filed Oct. 15, 2010, Weber et al.
 U.S. Appl. No. 13/152,259, filed Jun. 2, 2011, Kiani.
 U.S. Appl. No. 13/554,908, filed Jul. 20, 2012, Telfort et al.
 U.S. Appl. No. 13/554,929, filed Jul. 20, 2012, Telfort et al.

Office Action in Japanese Application No. 2011-544508 mailed Apr. 30, 2014.

International Preliminary Report on Patentability in PCT/US2010/052763 dated Apr. 17, 2012 in 9 pages.

International Preliminary Report on Patentability dated Apr. 15, 2014 for PCT Application No. PCT/US2012/060084.

European Search Report for Application No. 13185148.7 dated Dec. 6, 2013.

U.S. Appl. No. 10/180,518, filed Jun. 27, 2002, Lanzo et al.

U.S. Appl. No. 12/643,939, filed Dec. 21, 2009, Telfort et al.

U.S. Appl. No. 12/904,775, filed Oct. 14, 2010, Fechter et al.

U.S. Appl. No. 12/904,789, filed Oct. 14, 2010, Telfort, Valery et al.

U.S. Appl. No. 12/904,823, filed Oct. 14, 2010, Al-Ali et al.

U.S. Appl. No. 12/904,836, filed Oct. 14, 2010, Al-Ali et al.

U.S. Appl. No. 12/904,890, filed Oct. 14, 2010, Telfort et al.

U.S. Appl. No. 12/904,907, filed Oct. 14, 2010, Telfort et al.

U.S. Appl. No. 12/904,931, filed Oct. 14, 2010, Telfort, Valery et al.

U.S. Appl. No. 12/904,938, filed Oct. 14, 2010, Telfort et al.

U.S. Appl. No. 12/905,036, filed Oct. 14, 2010, Kiani et al.

U.S. Appl. No. 12/905,530, filed Oct. 15, 2010, Al-Ali et al.

U.S. Appl. No. 12/960,325, filed Dec. 3, 2010, Al-Ali, Ammar et al.

Analog Devices, 12-Bit Serial Input Multiplying D/A Converter, Product Data Sheet, 2000.

Avago Technologies, "HCNR200 and HCNR201, High-Linearity Analog Optocouplers," Data Sheet, Avago Technologies dated Nov. 18, 2008 in 19 pages.

Images showing tear down of a Measurement Specialties' stethoscope, Images taken on Sep. 7, 2007, in 38 pages.

Eldor, et al., "A device for monitoring ventilation during anaesthesia; the paratracheal audible Respiratory monitor", Canadian Journal of Anaesthesia, 1990, vol. 9, No. 1, p. 95-98.

Sierra et al., Monitoring Respiratory Rate Based on Tracheal Sounds. First Experiences, Proceedings of the 26th Annual Int'l Conf. of the IEEE EMBS (Sep. 2004), pp. 317-320.

Welch Allyn, ECG ASIC, Product Data Sheet, 2001.

WelchAllyn OEM Technologies, ECG ASIC, ECG 3-lead, 5-lead, 12-lead and RESP Signal Processing, ECG ASIC Part No. 000.91163 (2001) in 84 pages.

International Search Report & Written Opinion, PCT Application PCT/US2010/052758 dated Feb. 10, 2011 in 12 pages.

International Search Report & Written Opinion, PCT Application PCT/US2010/058981 dated Feb. 17, 2011 in 11 pages.

International Search Report, PCT Application PCT/US2009/069287 dated Mar. 30, 2010 in 7 pages.

International Search Report and Written Opinion in PCT/US2009/042902 mailed Aug. 12, 2009 in 19 pages.

International Search Report, PCT Application PCT/CA2003/000536 dated Dec. 11, 2003 in 2 pages.

Office Action issued in European Application No. 03711767.8 dated May 18, 2011 in 6 pages.

Japanese Office Action regarding Application No. 2007-506626 dated Mar. 1, 2011.

PCT Invitation to Pay Fees and Initial Search Report in PCT/US2010/052756 dated Oct. 5, 2011 in 4 pages.

International Search Report and Written Opinion in PCT/US2010/052756 mailed Feb. 6, 2012 in 15 pages.

PCT Invitation to Pay Fees and Initial Search Report in PCT/US2009/069287 dated Apr. 21, 2010 in 6 pages.

International Search Report and Written Opinion issued in PCT Application No. PCT/US2009/069287 dated Jun. 30, 2010 in 21 pages.

Office Action issued in European Application No. 10779086.7 dated Mar. 5, 2013 in 5 pages.

PCT Invitation to Pay Fees and Initial Search Report in PCT/US2010/052754 dated Mar. 15, 2011.

International Search Report and Written Opinion in PCT/US2010/052754 mailed Jul. 27, 2011 in 17 pages.

International Preliminary Report on Patentability (IPRP) in PCT/US2010/052754 dated Apr. 26, 2012 in 11 pages.

(56)

References Cited

OTHER PUBLICATIONS

International Search Report and Written Opinion in PCTUS2010052760 mailed Mar. 8, 2011 in 9 pages.

International Search Report and Written Opinion in PCT/US2010/052763 mailed May 13, 2011.

International Search Report and Written Opinion in PCT/US2012/060084 dated Dec. 21, 2012 in 11 pages.

P. White, "Advanced Compression Techniques, Tips & Tricks", Part 1 and Part 2, Dec. 2000 and Jan. 2001 in 11 pages.

US 8,740,816, 06/2014, Telfort et al. (withdrawn)

US 8,845,543, 09/2014, Diab et al. (withdrawn)

* cited by examiner

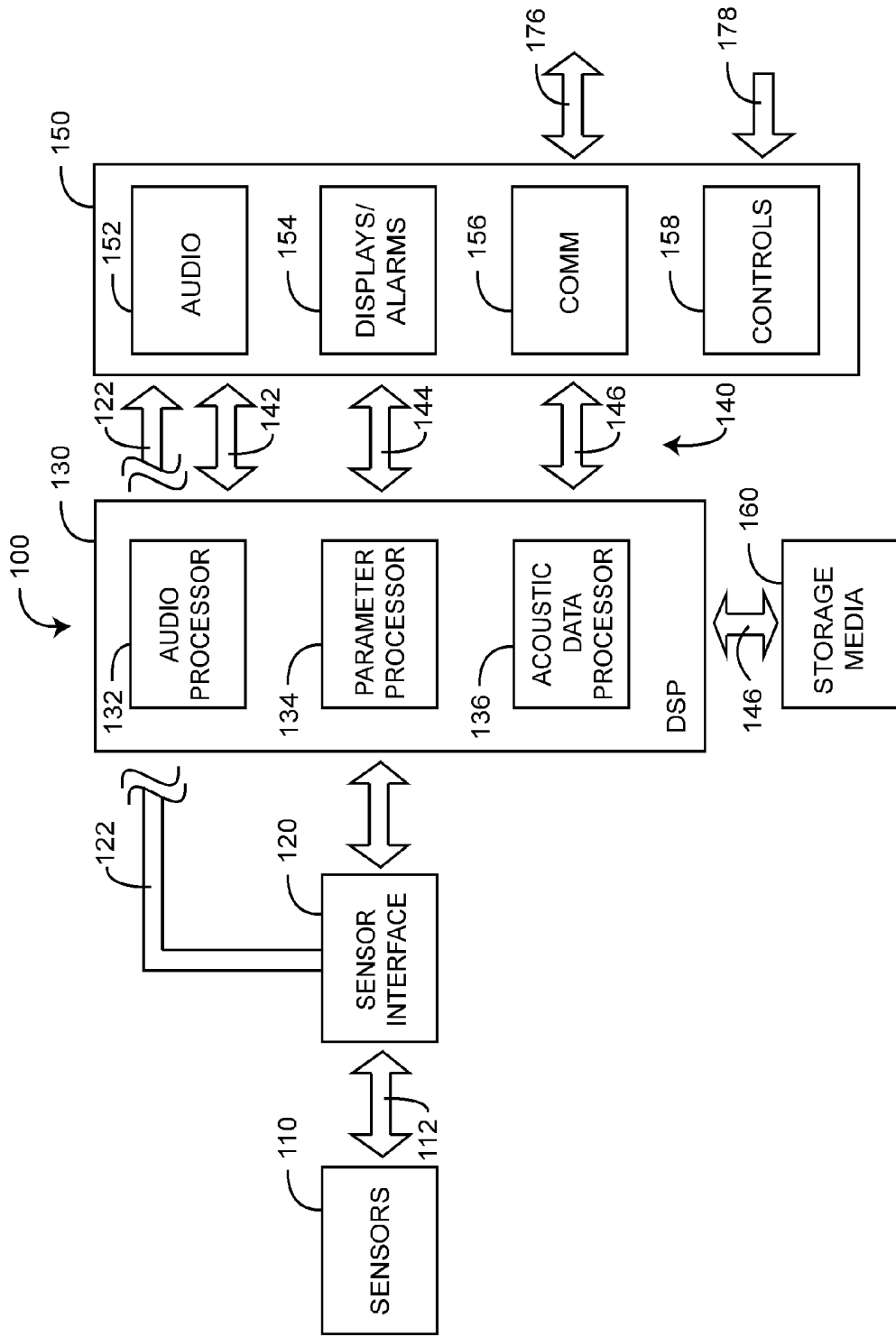

FIG. 1

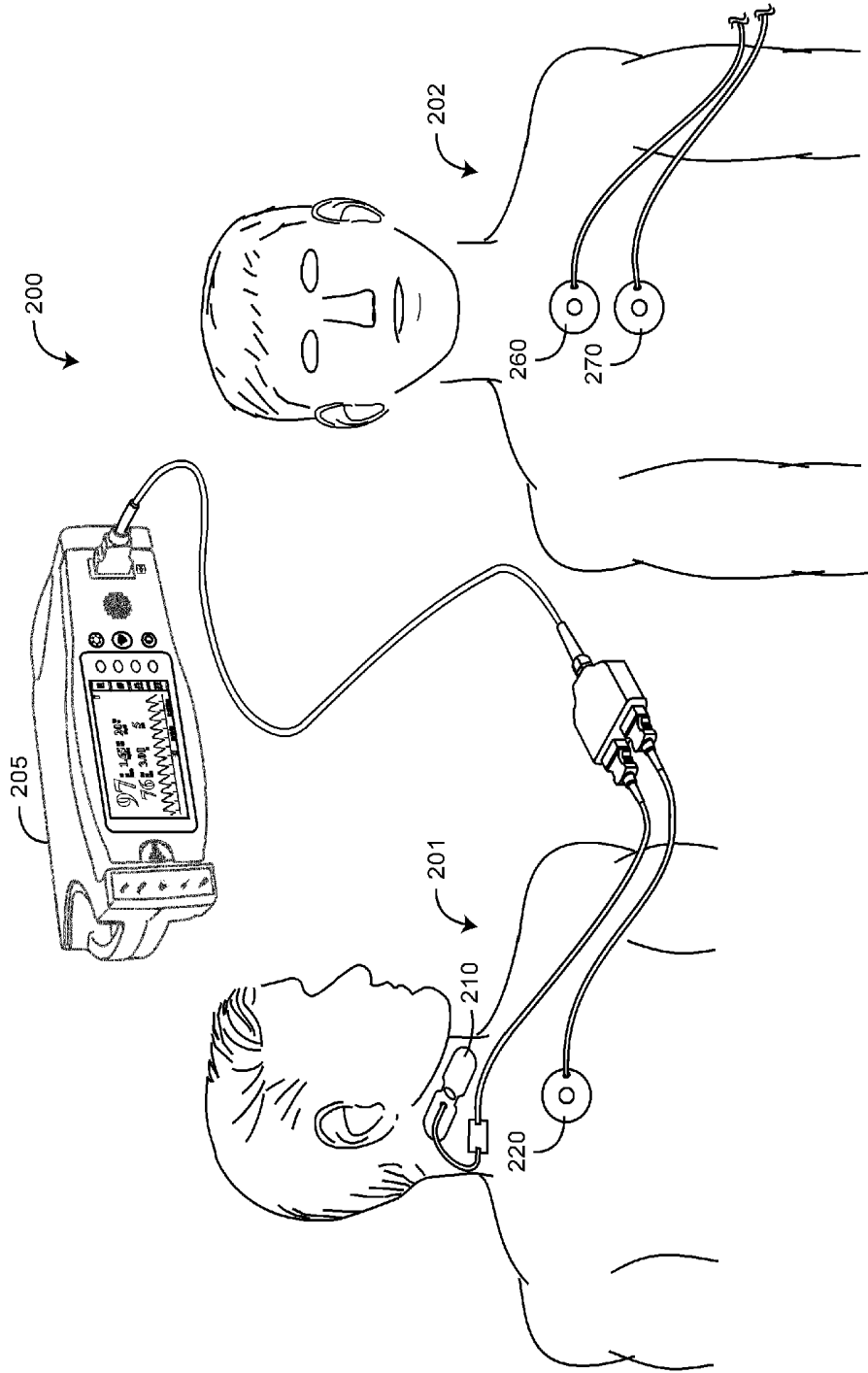

FIG. 2A

FIG. 2B

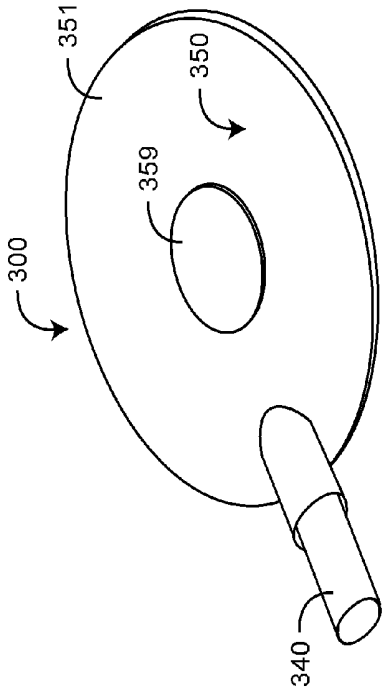

FIG. 3A

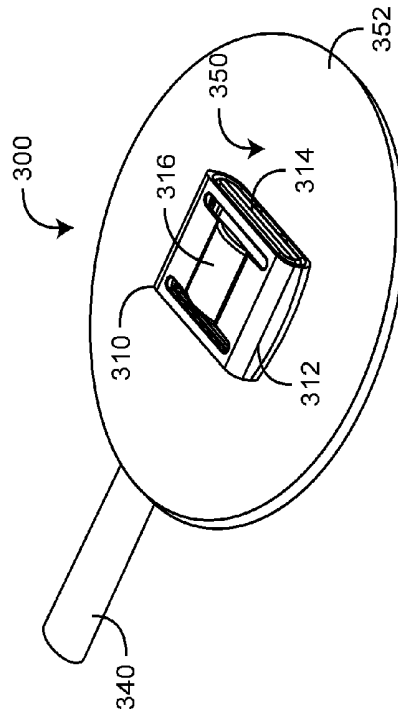

FIG. 3B

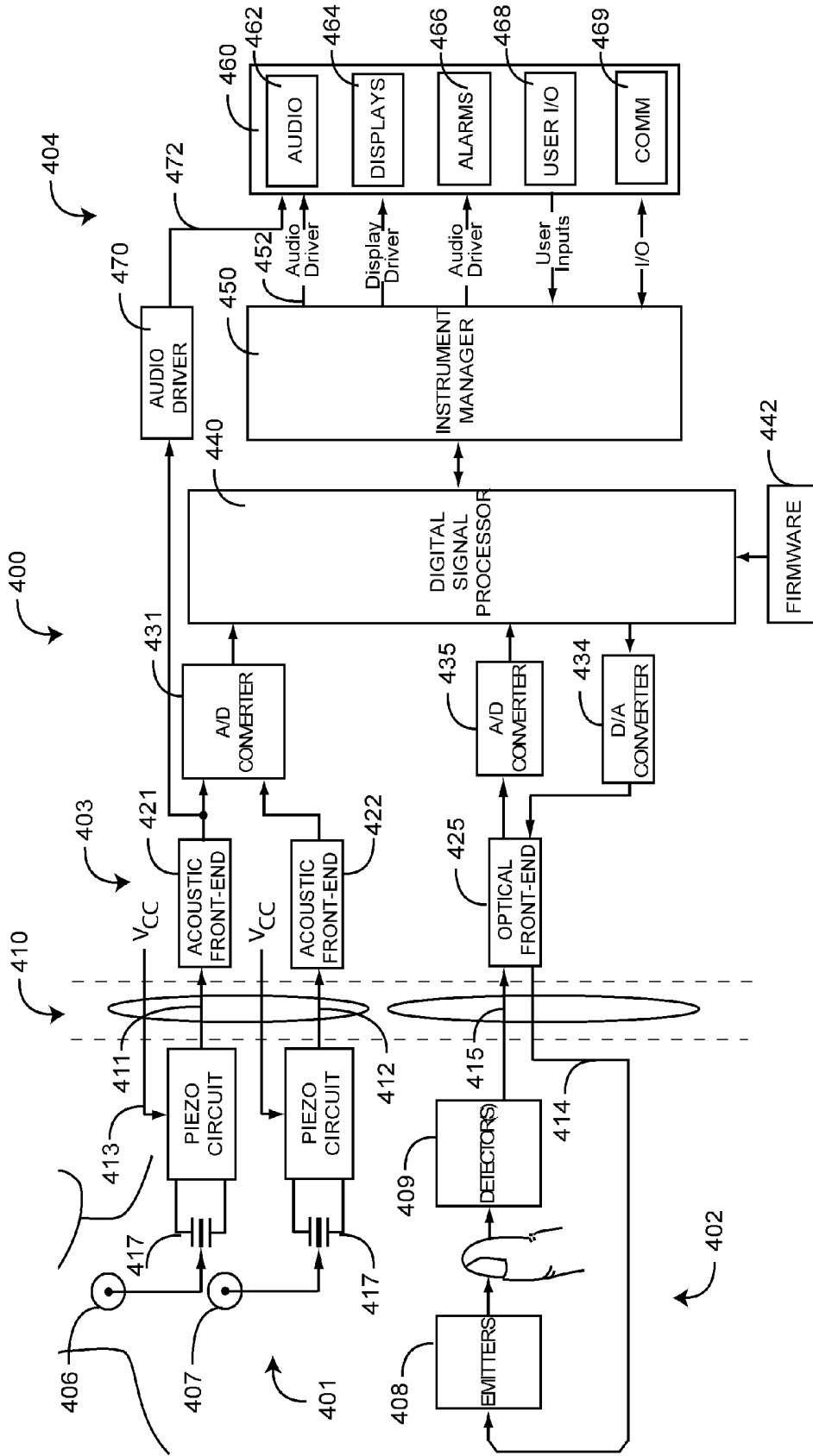

FIG. 4

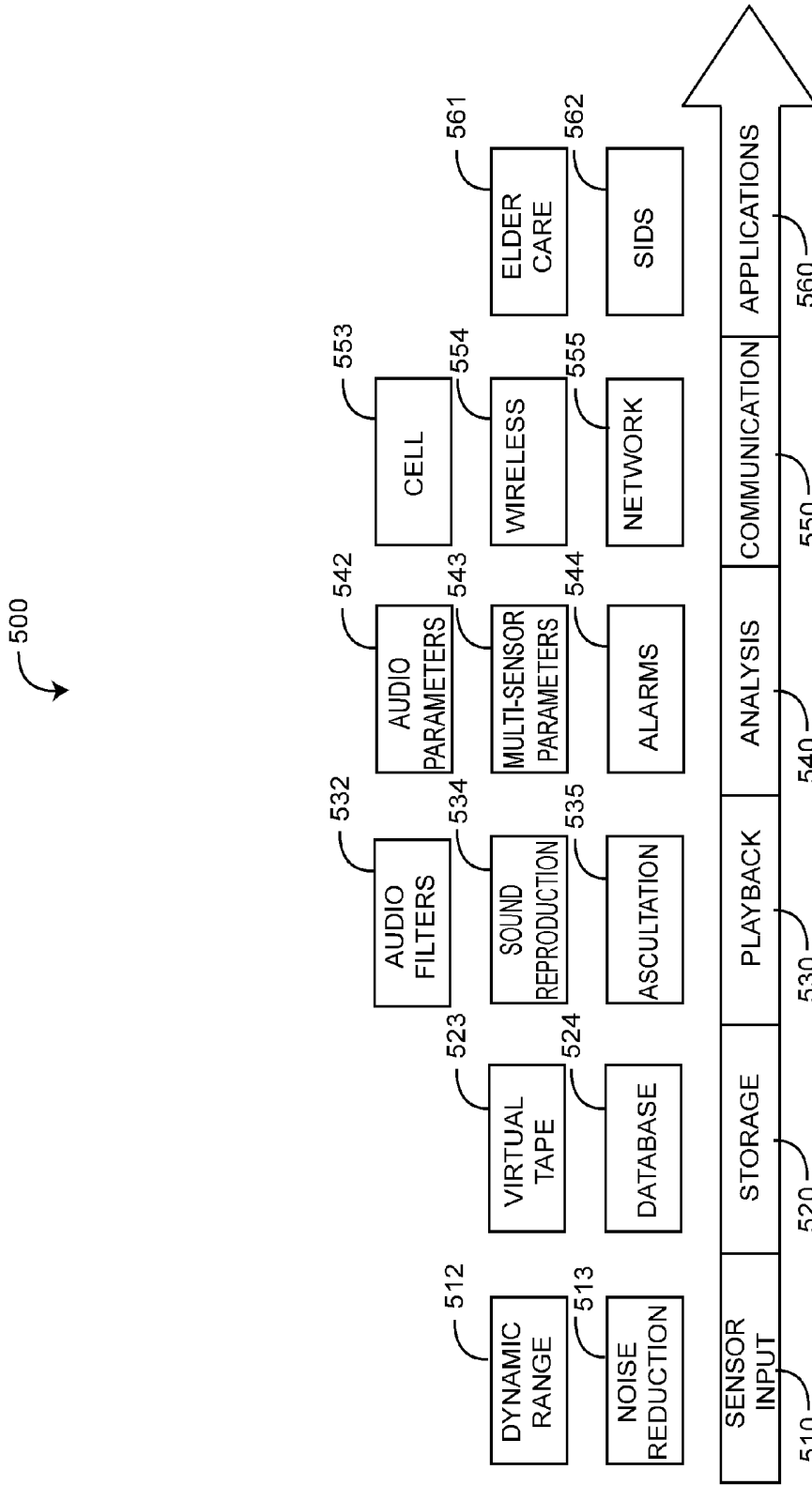

FIG. 5

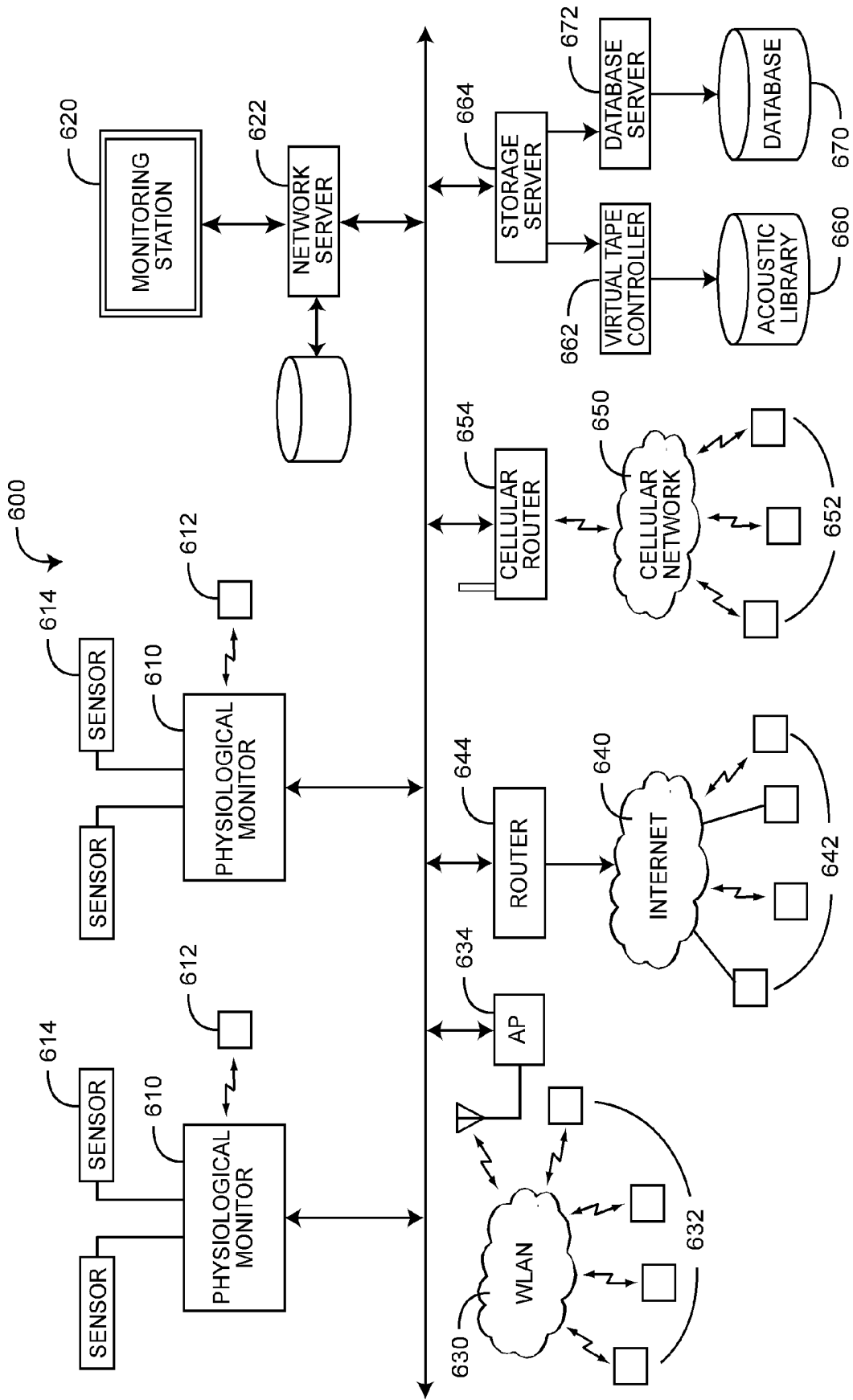

FIG. 6

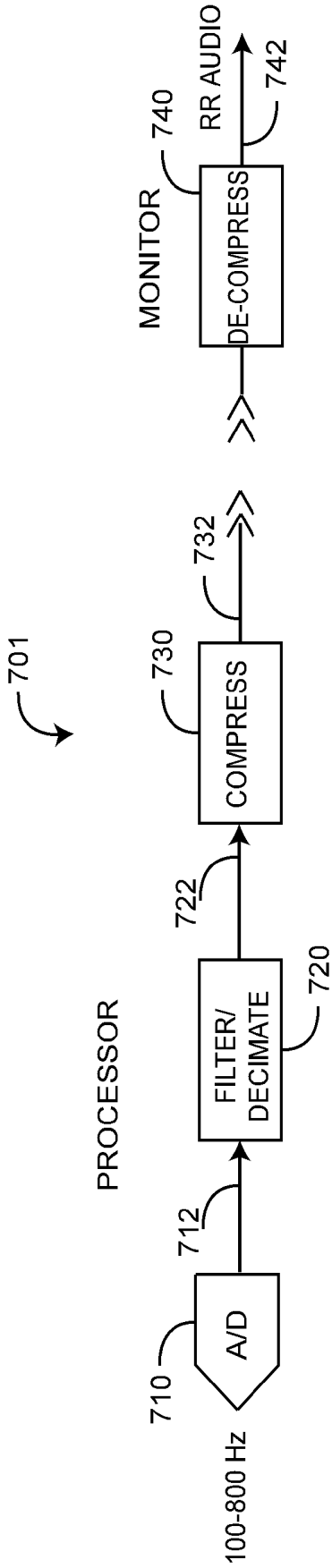

FIG. 7A

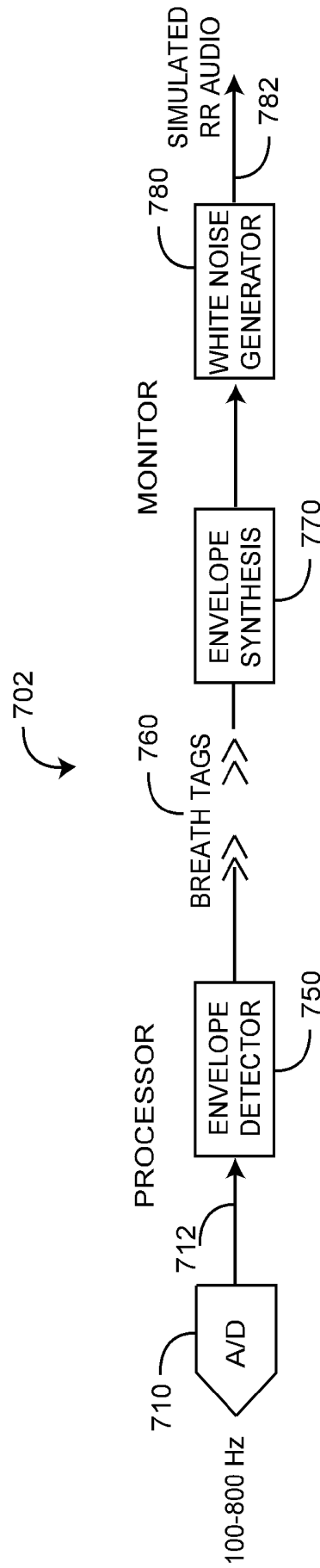

FIG. 7B

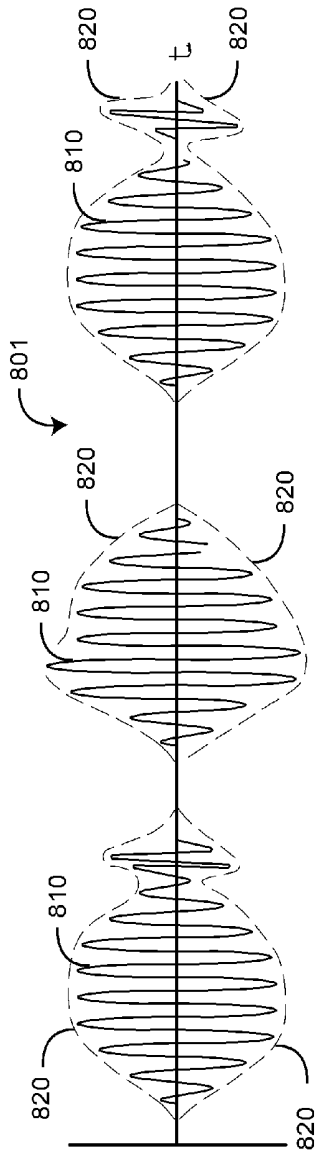

FIG. 8A

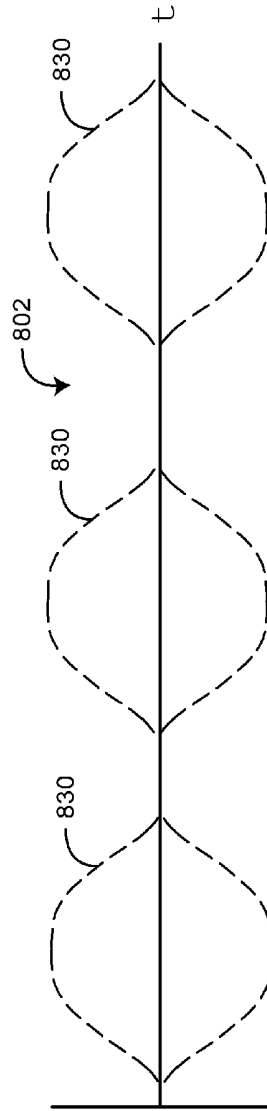

FIG. 8B

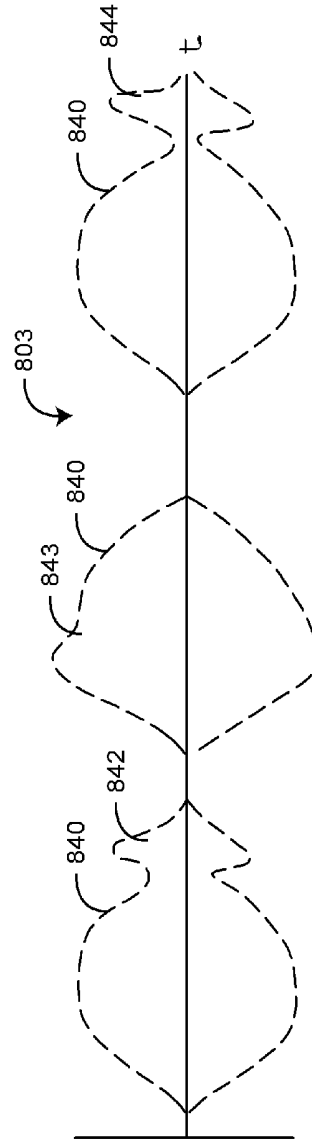

FIG. 8C

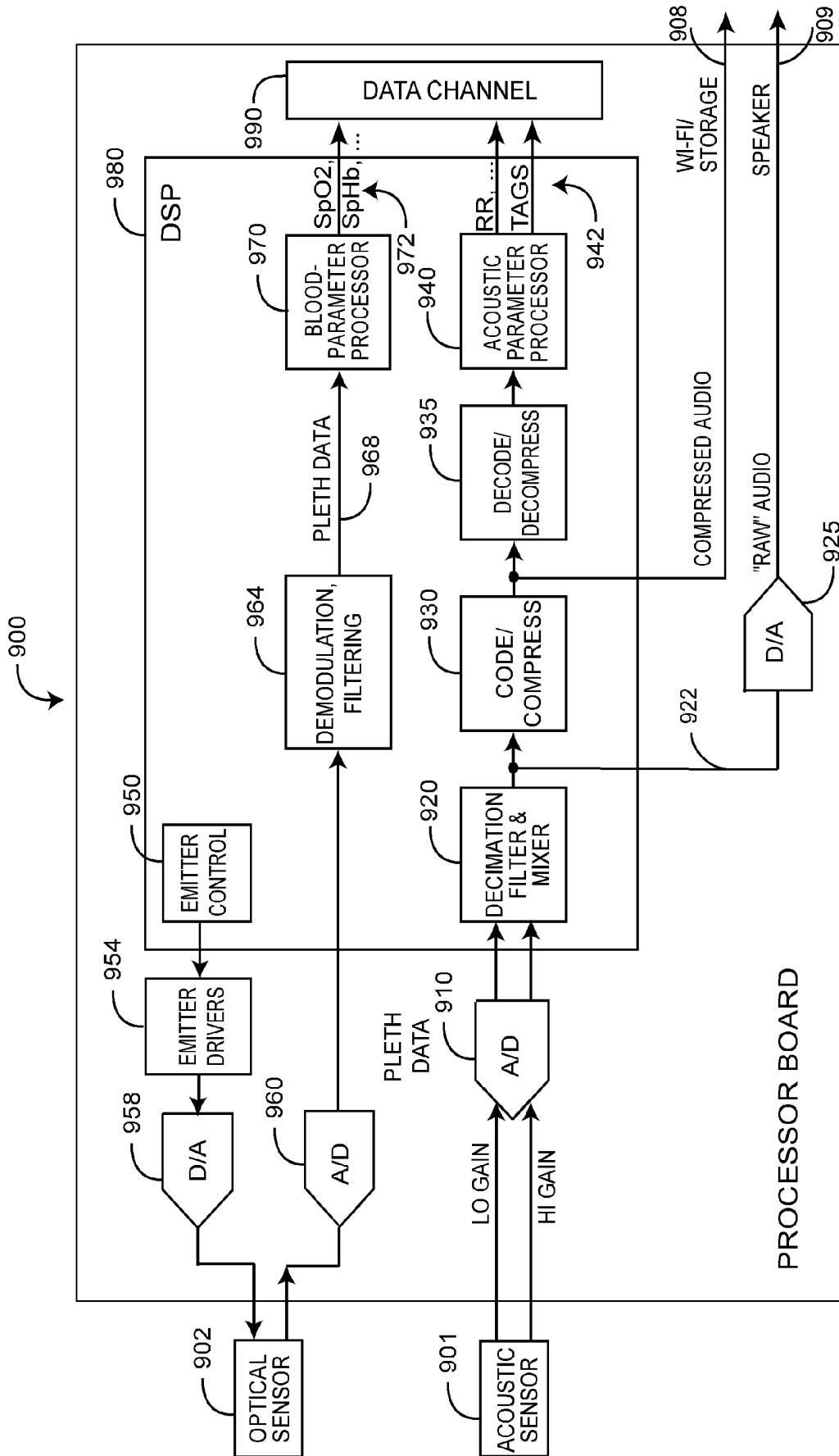

FIG. 9

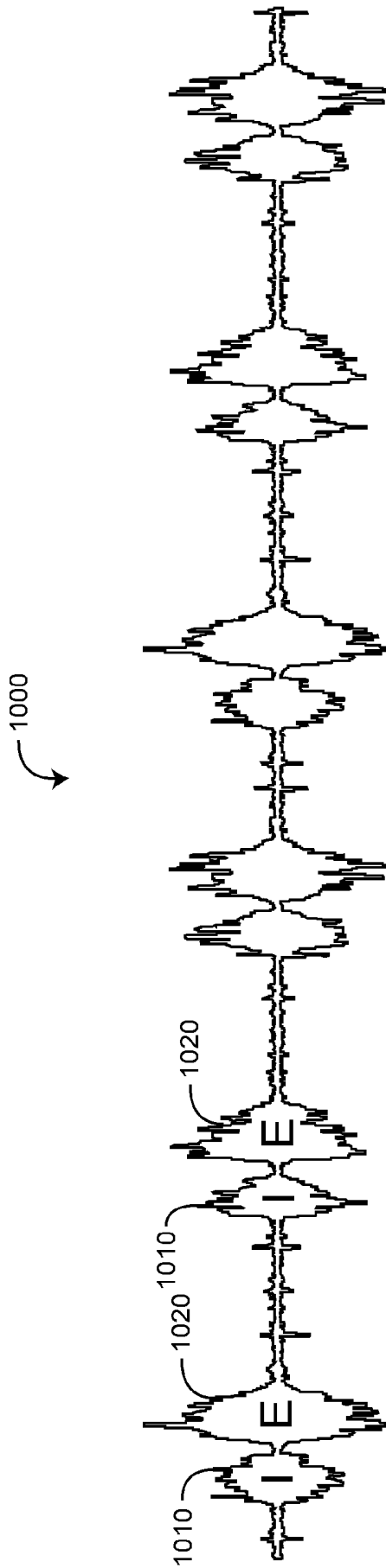

FIG. 10A

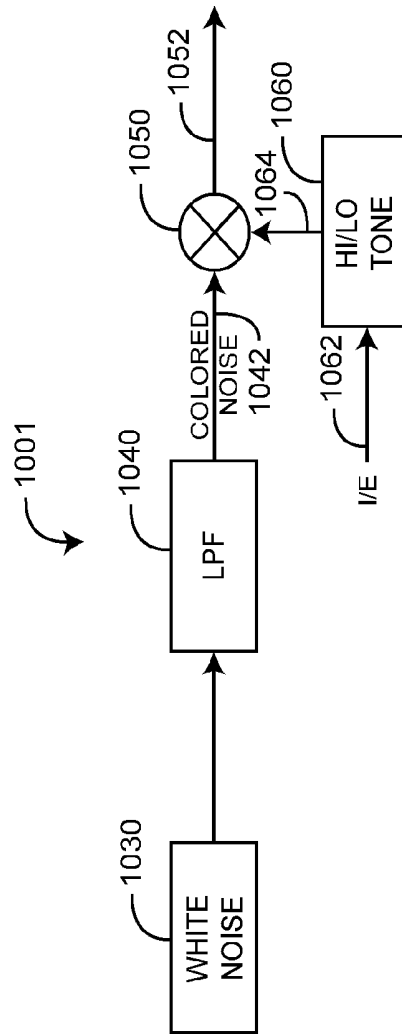

FIG. 10B

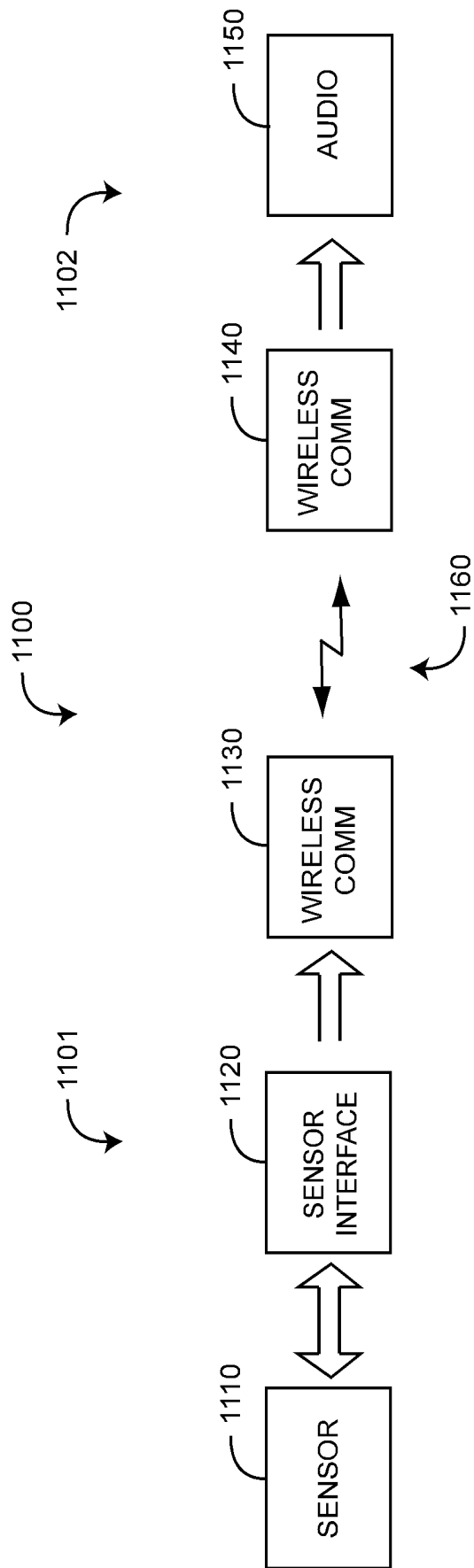

FIG. 11

PHYSIOLOGICAL ACOUSTIC MONITORING SYSTEM

This application is a continuation of U.S. patent application Ser. No. 13/650,775, filed Oct. 12, 2012, titled PHYSIOLOGICAL ACOUSTIC MONITORING SYSTEM, which claims the benefit of priority under 35 U.S.C. §119(e) of U.S. Provisional Patent Application No. 61/547,007, filed Oct. 13, 2011, titled Physiological Acoustic Monitoring System, and is a continuation-in-part of U.S. patent application Ser. No. 12/905,036, filed Oct. 14, 2010, now U.S. Pat. No. 8,821,415, titled Physiological Acoustic Monitoring System, which claims the benefit of priority under 35 U.S.C. §119(e) of U.S. Provisional Patent Application No. 61/252,099, filed Oct. 15, 2009, and U.S. Provisional Patent Application No. 61/391,098, filed Oct. 8, 2010, the disclosures of which are hereby incorporated in their entirety by reference herein. Additionally, this application relates to the following U.S. patent applications, the disclosures of which are incorporated in their entirety by reference herein:

App. No.	Filing Date	Title
60/893,853	Mar. 8, 2007	MULTI-PARAMETER PHYSIOLOGICAL MONITOR
60/893,850	Mar. 8, 2007	BACKWARD COMPATIBLE PHYSIOLOGICAL SENSOR WITH INFORMATION ELEMENT
60/893,858	Mar. 8, 2007	MULTI-PARAMETER SENSOR FOR PHYSIOLOGICAL MONITORING
60/893,856	Mar. 8, 2007	PHYSIOLOGICAL MONITOR WITH FAST GAIN ADJUST DATA ACQUISITION
12/044,883	Mar. 8, 2008	SYSTEMS AND METHODS FOR DETERMINING A PHYSIOLOGICAL CONDITION USING AN ACOUSTIC MONITOR
61/252,083	Oct. 15, 2009	<i>DISPLAYING PHYSIOLOGICAL INFORMATION</i>
12/904,823	Oct. 14, 2010	<i>BIDIRECTIONAL PHYSIOLOGICAL INFORMATION DISPLAY</i>
61/141,584	Dec. 30, 2009	<i>ACOUSTIC SENSOR ASSEMBLY</i>
61/252,076	Oct. 15, 2009	<i>ACOUSTIC SENSOR ASSEMBLY</i>
12/643,939	Dec. 21, 2009	<i>ACOUSTIC SENSOR ASSEMBLY</i>
61/313,645	Mar. 12, 2010	<i>ACOUSTIC RESPIRATORY MONITORING SENSOR HAVING MULTIPLE SENSING ELEMENTS</i>
12/904,890	Oct. 14, 2010	<i>ACOUSTIC RESPIRATORY MONITORING SENSOR HAVING MULTIPLE SENSING ELEMENTS</i>
12/904,931	Oct. 14, 2010	<i>ACOUSTIC RESPIRATORY MONITORING SENSOR HAVING MULTIPLE SENSING ELEMENTS</i>
12/904,938	Oct. 14, 2010	<i>ACOUSTIC RESPIRATORY MONITORING SENSOR HAVING MULTIPLE SENSING ELEMENTS</i>
12/904,907	Oct. 14, 2010	<i>ACOUSTIC PATIENT SENSOR</i>
12/904,789	Oct. 14, 2010	<i>ACOUSTIC RESPIRATORY MONITORING SYSTEMS AND METHODS</i>
61/252,062	Oct. 15, 2009	<i>PULSE OXIMETRY SYSTEM WITH LOW NOISE CABLE HUB</i>
61/265,730	Dec. 1, 2009	<i>PULSE OXIMETRY SYSTEM WITH ACOUSTIC SENSOR</i>
12/904,775	Oct. 14, 2010	<i>PULSE OXIMETRY SYSTEM WITH LOW NOISE CABLE HUB</i>
12/905,036	Oct. 14, 2010	<i>PHYSIOLOGICAL ACOUSTIC MONITORING SYSTEM</i>
61/331,087	May 4, 2010	<i>ACOUSTIC RESPIRATION DISPLAY</i>
14/473,831	Aug. 29, 2014	<i>PHYSIOLOGICAL ACOUSTIC MONITORING SYSTEM</i>

Many of the embodiments described herein are compatible with embodiments described in the above related applications. Moreover, some or all of the features described herein

can be used or otherwise combined with many of the features described in the applications listed above.

BACKGROUND OF THE INVENTION

The “piezoelectric effect” is the appearance of an electric potential and current across certain faces of a crystal when it is subjected to mechanical stresses. Due to their capacity to convert mechanical deformation into an electric voltage, piezoelectric crystals have been broadly used in devices such as transducers, strain gauges and microphones. However, before the crystals can be used in many of these applications they must be rendered into a form which suits the requirements of the application. In many applications, especially those involving the conversion of acoustic waves into a corresponding electric signal, piezoelectric membranes have been used.

Piezoelectric membranes are typically manufactured from polyvinylidene fluoride plastic film. The film is endowed with piezoelectric properties by stretching the plastic while it is placed under a high-poling voltage. By stretching the film, the film is polarized and the molecular structure of the plastic aligned. A thin layer of conductive metal (typically nickel-copper) is deposited on each side of the film to form electrode coatings to which connectors can be attached.

Piezoelectric membranes have a number of attributes that make them interesting for use in sound detection, including: a wide frequency range of between 0.001 Hz to 1 GHz; a low acoustical impedance close to water and human tissue; a high dielectric strength; a good mechanical strength; and piezoelectric membranes are moisture resistant and inert to many chemicals.

Due in large part to the above attributes, piezoelectric membranes are particularly suited for the capture of acoustic waves and the conversion thereof into electric signals and, accordingly, have found application in the detection of body sounds. However, there is still a need for a reliable acoustic sensor, particularly one suited for measuring bodily sounds in noisy environments.

SUMMARY OF THE INVENTION

An aspect of a physiological acoustic monitoring system receives physiological data from an acoustic sensor, down-samples the data to generate raw audio of breathing sounds and compresses the raw audio. The acoustic monitoring system has an acoustic sensor signal responsive to tracheal sounds in a person. An A/D converter is responsive to the sensor signal so as to generate breathing sound data. A decimation filter and mixer down-samples the breathing sound data to raw audio data. A coder/compressor generates compressed audio data from the raw audio data. A decoder/decompressor decodes and decompresses the compressed audio data into decompressed audio data. The decompressed audio data is utilized to generate respiration-related parameters in real-time. The compressed audio data is stored and retrieved so as to generate respiration-related parameters in non-real-time. The real-time and non-real-time parameters are compared to verify matching results across multiple monitors.

Another aspect of a physiological acoustic monitoring system inputs an acoustic sensor signal responsive to tracheal sounds of a person and generates breath tags and a respiration rate. The breath tags represent the acoustic envelope of the tracheal sound, and the respiration rate represents the inverse period of the acoustic envelope. The breath tags and respiration rate have a sufficiently low bandwidth to share a data channel with other physiological parameters. In an embodiment, the acoustic monitor has an acoustic sensor input and an A/D converter that digitizes the sensor input and outputs a

digitized sensor signal. A decimation filter and mixer reduces the data rate of the digitized sensor signal and outputs a digitized raw audio. An acoustic parameter processor generates a respiration rate and breath tags in response to the digitized raw audio.

In various embodiments, the acoustic monitoring system has a coder/compressor that compresses the digitized raw audio to generate compressed audio data, which is stored and retrieved so as to generate respiration-related parameters in non-real-time. A decoder/decompressor decompresses the compressed audio data for the acoustic parameter processor. A D/A converter inputs the digitized raw audio and generates a raw audio analog signal for local playback and listening to the acoustic sensor signal. The compressed audio is transmitted to a remote location as a troubleshooting aid at a remote monitor.

A further aspect of a physiological acoustic monitoring system inputs a sensor signal responsive to respiratory sounds of a living being, digitizes the sensor signal so as to generate acoustic data, extracts an envelope from the acoustic data, defines an idealized envelope from the extracted envelope, describes the idealized envelope as breath tags and transmits the breath tags over a data channel. In various embodiments, the breath tags are received from the data channel, a reconstructed envelope is synthesized in response to the breath tags and reconstructed acoustic data is generated by filling the envelope with an artificial waveform. In an embodiment, the artificial waveform is white noise.

An additional aspect of a physiological acoustic monitoring system detects a physiological feature in the extracted envelope and includes the physiological feature in the breath tags. The reconstructed envelope is modified with the detected physiological feature, which may be wheezing or coughing, as examples. The respiratory sounds are approximately reproduced by playing the reconstructed acoustic data on an audio transducer.

Yet another aspect of a physiological acoustic monitoring system is a sensor signal responsive to respiratory sounds of a living being. An A/D converter digitizes the sensor signal into acoustic data. A parameter generator extracts a respiratory sound envelope from the acoustic data so as to generate a breath tag, which is transmitted over a data channel as a representation of the respiratory sounds. In various embodiments, a remote monitoring station receives the breath tag and a corresponding respiration rate. The monitoring station synthesizes an envelope from the breath tag and the respiration rate and fills the envelope with an artificial waveform so as to generate reconstituted respiratory sounds. In an embodiment, the artificial waveform is white noise.

In various other embodiments, a decimation filter and mixer down-samples the acoustic data to raw audio data, a D/A converter converts the raw audio data to a raw audio signal and a speaker that plays the raw audio signal. The parameter generator detects a physiological feature in the extracted envelope and includes the physiological feature in the breath tag. The remote monitor modifies the reconstructed envelope with the detected physiological feature. An audio transducer approximately reproduces the reconstructed acoustic data as compared to the raw audio signal. A compressor generates compressed audio data, which is stored and retrieved so as to generate respiration-related parameters in non-real-time.

BRIEF DESCRIPTION OF THE DRAWINGS

FIG. 1 is a general block diagram of a physiological acoustic monitoring system;

FIGS. 2A-B are illustrations of dual channel acoustic sensors;

FIG. 2A illustrates a neck sensor for physiological measurements and a chest sensor for monaural body sound monitoring;

FIG. 2B illustrates a dual acoustic sensor for stereo body sound monitoring;

FIGS. 3A-B are top and bottom perspective views of a body sound sensor;

FIG. 4 is a general schematic diagram of acoustic and optical sensors and sensor drive elements and a corresponding digital signal processor and I/O drive elements;

FIG. 5 is a matrix diagram of processor modules and corresponding functionality;

FIG. 6 is a network diagram for a physiological acoustic monitoring system;

FIGS. 7A-B are block diagrams of respiration sound generator embodiments;

FIGS. 8A-C are graphs illustrating breath tag generator embodiments;

FIG. 9 is a block diagram illustrating a physiological parameter processor embodiment for generating acoustic and optical sensor parameters, breath tags and compressed and raw audio outputs;

FIGS. 10A-B are a waveform and a block diagram illustrating a respiration beep generator embodiment; and

FIG. 11 is a block diagram of a physiological acoustic monitoring system for wireless monitoring applications.

DETAILED DESCRIPTION OF THE PREFERRED EMBODIMENTS

FIG. 1 generally illustrates a physiological acoustic monitoring system **100** embodiment having one or more sensors **110** in communications with one or more processors **130** via a sensor interface **120**. The processors **130** both initiate and respond to input/output **150**, including audio output **152**, displays and alarms **154**, communications **156** and controls **158**. In an embodiment, the processors **130** are implemented in firmware executing on one or more digital signal processors (DSP), as described with respect to FIGS. 4-5, below. At least a portion of the sensors **110** generate acoustic signals, which may be directly utilized by the processors **130** or recorded onto or played back from storage media **160** or both.

The processors **130** include an audio processor **132** that outputs audio waveforms **142**, a parameter processor **134** that derives physiological parameters **144** from sensor signals **112** and an acoustic data processor **136** that stores, retrieves and communicates acoustic data **146**. Parameters include, as examples, respiration rate, heart rate and pulse rate. Audio waveforms include body sounds from the heart, lungs, gastrointestinal system and other organs. These body sounds may include tracheal air flow, heart beats and pulsatile blood flow, to name a few. Displays allow parameters **144** and acoustic data **146** to be visually presented to a user in various forms such as numbers, waveforms and graphs, as examples. Audio **152** allows audio waveforms to be reproduced through speakers, headphones or similar transducers. Raw audio **122** allows acoustic sensor signals **112** to be continuously reproduced through speakers, headphones or similar transducers, bypassing A/D conversion **120** and digital signal processing **130**.

Storage media **160** allows acoustic data **146** to be recorded, organized, searched, retrieved and played back via the processors **130**, communications **156** and audio output **152**. Communications **156** transmit or receive acoustic data or audio waveforms via local area or wide area data networks or cellular networks **176**. Controls **158** may cause the audio processor **132** to amplify, filter, shape or otherwise process

audio waveforms **142** so as to emphasize, isolate, deemphasize or otherwise modify various features of an audio waveform or spectrum. In addition, controls **158** include buttons and switches **178**, such as a “push to play” button that initiates local audio output **152** or remote transmission **176** of live or recorded acoustic waveforms.

As shown in FIG. 1, acoustic data **146** is initially derived from one or more acoustic sensor signals **112**, along with, perhaps, other data inputs, such as from optical, blood pressure, EEG and ECG sensors, to name a few. The acoustic data **146** provides audio outputs **142**, including audio respiration indicators, described with respect to FIGS. 7-10, below. The acoustic data **146**, when analyzed, provides physiological parameters **144** that provide an indication of patient status, such as respiration rate or heart rate. Such analyses may result in visual or audible alerts or alarms **154** that are viewed locally or via notifications transmitted over local or wide area networks **176** to medical staff or other persons. Acoustic data **146** is utilized in real time or stored and retrieved for later use. Acoustic data **146** may be written on various storage media **160**, such as a hard drive, and organized for convenient search and retrieval. In an embodiment, acoustic data **146** is advantageously organized on one or more hard drives as virtual magnetic tape so as to more easily manage, search, retrieve and playback acoustic data volumes. Further, the virtual tape volumes and/or the acoustic data itself may be entered into a database and organized as an acoustic library according to various search parameters including patient information, dates, corresponding physiological parameters and acoustic waveform features, to name a few. Applications for a physiological acoustic monitoring system include auscultation of body sounds by medical staff or by audio processors or both; SIDS monitoring; heart distress monitoring including the early detection and mitigation of myocardial infarction and cardiopulmonary arrest, as examples; and elder care, to name a few.

In an embodiment, sensor sounds **142** may be continuously “piped” to a remote device/listener or a central monitor or both. Listening devices may variously include pagers, cell phones, PDAs, electronic pads or tablets and laptops or other computers to name a few. Medical staff or other remote listeners are notified by the acoustic monitoring system according to flexible pre-programmed protocols to respond to the notification so as to hear breathing sounds, voice, heart sounds or other body sounds.

FIGS. 2A-B illustrate physiological acoustic monitoring system **200** embodiments each having dual channel acoustic sensors **201**, **202** in communications with a physiological monitor **205**. As shown in FIG. 2A, a first acoustic sensor **210** is utilized for deriving one or more physiological parameters, such as respiration rate. A second acoustic sensor **220** is utilized to continuously monitor body sounds. In an embodiment, the second acoustic sensor **220** has a different color or shape than the first acoustic sensor **210** so as to identify the sensor as a body sound listening device rather than an acoustic sensing device for determining a physiological parameter. In an embodiment, the body sound sensor **220** is placed over the heart to allow the monitoring of heart sounds or for determination of heart rate. In an embodiment, the body sound sensor **220** generates a signal that bypasses monitor digitization and signal processing so as to allow continuous listening of the unprocessed or “raw” body sounds. In particular, the first acoustic sensor **210** is neck-mounted so as to determine one or more physiological parameters, such as respiration rate. The second acoustic sensor **220** is chest-mounted for monaural heart sound monitoring. As shown in FIG. 2B, first and second acoustic sensors **260**, **270** are mounted proximate

the same body site but with sufficient spatial separation to allow for stereo sensor reception. In this manner, the listener can more easily distinguish and identify the source of body sounds.

FIGS. 3A-B illustrate a body sound sensor **300** having acoustic **310**, interconnect (not visible) and attachment **350** assemblies. The acoustic assembly **310** has an acoustic coupler **312** and a piezoelectric subassembly **314**. The acoustic coupler **312** generally envelops or at least partially covers some or all of the piezoelectric subassembly **314**. The piezoelectric subassembly **314** includes a piezoelectric membrane and a support frame (not visible). The piezoelectric membrane is configured to move on the frame in response to acoustic vibrations, thereby generating electrical signals indicative of body sounds. The acoustic coupler **312** advantageously improves the coupling between the acoustic signal measured at a skin site and the piezoelectric membrane. The acoustic coupler **312** includes a contact portion **316** placed against a person’s skin.

Further shown in FIGS. 3A-B, the acoustic assembly **310** communicates with the sensor cable **340** via the interconnect assembly. In an embodiment, the interconnect assembly is a flex circuit having multiple conductors that are adhesively bonded to the attachment assembly **350**. The interconnect assembly has a solder pad or other interconnect to interface with the sensor cable **340**, and the attachment assembly **350** has a molded strain relief for the sensor cable. In an embodiment, the attachment assembly **350** is a generally circular, planar member having a top side **3511**, a bottom side **352**, and a center. A button **359** mechanically couples the acoustic assembly **310** to the attachment assembly center so that the acoustic assembly **310** extends from the bottom side **352**. The sensor cable **340** extends from one end of the interconnect and attachment assemblies to a sensor connector at an opposite end so as to provide communications between the sensor and a monitor, as described in further detail with respect to, below. In an embodiment, an adhesive along the bottom side **352** secures the acoustic assembly **310** to a person’s skin, such as at a neck, chest, back, abdomen site. A removable backing can be provided with the adhesive to protect the adhesive surface prior to affixing to a person’s skin. In other embodiments, the attachment assembly **350** has a square, oval or oblong shape, so as to allow a uniform adhesion of the sensor to a measurement site. In a resposable embodiment, the attachment assembly **350** or portions thereof are removably detachable and attachable to the acoustic assembly **310** for disposal and replacement. The acoustic assembly **310** is reusable accordingly.

FIG. 4 illustrates acoustic **401** and optical **402** sensors and sensor drive elements **403** and a corresponding digital signal processor **440** and I/O drive elements **404**. A multi-acoustic sensor configuration **401** includes a power interface **413**, piezo circuits **416** and a piezoelectric membrane **417** corresponding to each sensor head **406**, **407**. The piezoelectric membrane **417** senses vibrations and generates a voltage in response to the vibrations, as described with respect to the sensor of FIGS. 3A-B, above. The signal generated by the piezoelectric membrane is communicated to the piezo circuit **416**, described immediately below, and transmits the signal to the monitor **205** (FIG. 2A) for signal conditioning and processing. The piezo circuit **416** decouples the power supply **413** and performs preliminary signal conditioning. In an embodiment, the piezo circuit **416** includes clamping diodes to provide electrostatic discharge (ESD) protection and a mid-level voltage DC offset for the piezoelectric signal to ride on, to be superimposed on or to be added to. The piezo circuit may also have a high pass filter to eliminate unwanted low

frequencies such as below about 100 Hz for breath sound applications, and an op amp to provide gain to the piezoelectric signal. The piezo circuit 416 may also have a low pass filter on the output of the op amp to filter out unwanted high frequencies. In an embodiment, a high pass filter is also provided on the output in addition to or instead of the low pass filter. The piezo circuit may also provide impedance compensation to the piezoelectric membrane, such as a series/parallel combination used to control the signal level strength and frequency of interest that is input to the op amp. In one embodiment, the impedance compensation is used to minimize the variation of the piezoelectric element output. The impedance compensation can be constructed of any combination of resistive, capacitive and inductive elements, such as RC or RLC circuits.

As shown in FIG. 4, a physiological acoustic monitor 400 embodiment drives and processes signals from a multi-acoustic sensor 401 and an optical sensor 402. The monitor 400 includes one or more acoustic front-ends 421, 422, an analog-to-digital (A/D) converter 431, an audio driver 470 and a digital signal processor (DSP) 440. The DSP 440 can comprise a wide variety of data and/or signal processors capable of executing programs for determining physiological parameters from input data. An optical front-end 425, digital-to-analog (D/A) converters 434 and an A/D converter 435 drive emitters 408 and transform resulting composite analog intensity signal(s) from light sensitive detector(s) 409 received via a sensor cable 410 into digital data input to the DSP 440. The acoustic front-ends 421, 422 and A/D converter 431 transform analog acoustic signals from piezoelectric elements 401 into digital data input to the DSP 440. The A/D converter 431 is shown as having a two-channel analog input and a multiplexed digital output to the DSP. In another embodiment, each front-end, communicates with a dedicated single channel A/D converter generating two independent digital outputs to the DSP. An acoustic front-end 421 can also feed an acoustic sensor signal 411 directly into an audio driver 470 for direct and continuous acoustic reproduction of an unprocessed (raw) sensor signal by a speaker, earphones or other audio transducer 462, as described with respect to FIG. 9, below.

Also shown in FIG. 4, the physiological acoustic monitor 400 may also have an instrument manager 450 that communicates between the DSP 440 and input/output 460. One or more I/O devices 460 have communications with the instrument manager 450 including displays, alarms, user I/O and instrument communication ports. Alarms 466 may be audible or visual indicators or both. The user I/O 468 may be, as examples, keypads, touch screens, pointing devices or voice recognition devices, to name a few. The displays 464 may be indicators, numerics or graphics for displaying one or more of various physiological parameters or acoustic data. The instrument manager 450 may also be capable of storing or displaying historical or trending data related to one or more of parameters or acoustic data.

Further shown in FIG. 4, the physiological acoustic monitor 400 may also have a "push-to-talk" feature that provides a "listen on demand" capability. That is, a button 468 on the monitor is pushed or otherwise actuated so as to initiate acoustic sounds to be sent to a speaker, handheld device, or other listening device, either directly or via a network. The monitor 400 may also have a "mode selector" button or switch 468 that determines the acoustic content provided to a listener, either local or remote. These controls may be actuated local or at a distance by a remote listener. In an embodiment, push on demand audio occurs on an alarm condition in lieu of or in addition to an audio alarm. Controls 468 may include output filters like on a high quality stereo system so that a

clinician or other user could selectively emphasize or deemphasize certain frequencies so as to hone-in on particular body sounds or characteristics.

In various embodiments, the monitor 400 may be one or more processor boards installed within and communicating with a host instrument. Generally, a processor board incorporates the front-end, drivers, converters and DSP. Accordingly, the processor board derives physiological parameters and communicates values for those parameters to the host instrument. Correspondingly, the host instrument incorporates the instrument manager and I/O devices. A processor board may also have one or more microcontrollers (not shown) for board management, including, for example, communications of calculated parameter data and the like to the host instrument. A processor board embodiment is described with respect to FIG. 9, below.

Communications 469 may transmit or receive acoustic data or audio waveforms via local area or wide area data networks or cellular networks. Controls may cause the audio processor to amplify, filter, shape or otherwise process audio waveforms so as to emphasize, isolate, deemphasize or otherwise modify various features of the audio waveform or spectrum. In addition, switches, such as a "push to play" button can initiate audio output of live or recorded acoustic data. Controls may also initiate or direct communications.

FIG. 5 illustrates processor modules 500 that may execute on a DSP 440 (FIG. 4) and/or instrument manager 450 (FIG. 4) in various physiological acoustic monitoring system embodiments and the corresponding functionality of these modules. Module functionality includes processing sensor input 510, storage 520 and playback 530 of acoustic data, acoustic data analysis 540, communication of acoustic data and derived physiological parameters 550 and specific applications 560. Sensor input 510 related modules include dynamic range 512 and noise reduction 513. Dynamic range 512 functionality is described with respect to the processor board codec and FIG. 9, below. Storage 520 related modules include virtual tape 523 and database 524 functionality, described with respect to FIG. 6, below. Playback 530 functionality includes audio filters 532, sound reproduction 534 including mono/stereo/quadrasonic 533 modes and auscultation 535 enhancement. Analysis 540 related modules include audio parameters 542, multi-sensor parameters 543 and corresponding alarms 544. Communications 550 related modules include cellular 553, wireless 554 and network 555 modes. Wireless is described with respect to FIG. 11, below, and cellular 553 and networks 555 are described with respect to FIG. 6, below. Applications 560 include elder care 561 and SIDS 562, described with respect to FIG. 12, below.

FIG. 6 illustrates a physiological acoustic monitoring system 600 embodiment having a shared or open network architecture interconnecting one or more physiological monitors 610, monitoring stations 620 and mass storage 660. This interconnection includes proximity wireless devices 612 in direct wireless communication with a particular physiological monitor 610; local wireless devices 632 in communications with the monitors 610 via a wireless LAN 630; and distant wired or wireless devices 642, 652 in communications with the monitors 610 via WAN, such as Internet 640 or cellular networks 650. Communication devices may include local and remote monitoring stations 620 and wired or wireless communications and/or computing devices including cell phones, lap tops, pagers, PDAs, tablets and pads, to name a few. Physiological information is transmitted/received directly to/from end users over LAN or WAN. End users such as clinicians may carry wireless devices 632 in communications with the WLAN 630 so as to view in real-time physi-

ological parameters or listen to audio data and waveforms on demand or in the event of an alarm or alert.

The network server **622** in certain embodiments provides logic and management tools to maintain connectivity between physiological monitors, clinician notification devices and external systems, such as EMRs. The network server **622** also provides a web based interface to allow installation (provisioning) of software related to the physiological monitoring system, adding new devices to the system, assigning notifiers to individual clinicians for alarm notification, escalation algorithms in cases where a primary caregiver does not respond to an alarm, interfaces to provide management reporting on alarm occurrences and internal journaling of system performance metrics such as overall system uptime. The network server **622** in certain embodiments also provides a platform for advanced rules engines and signal processing algorithms that provide early alerts in anticipation of a clinical alarm.

As shown in FIG. 6, audio data and corresponding audio files are advantageously stored on virtual tape **662**, which provides the storage organization of tape cartridges without the slow, bulky, physical storage of magnetic tape and the corresponding human-operator intervention to physically locate and load physical cartridges into an actual tape-drive. A virtual tape controller **662** emulates standard tape cartridges and drives on modern, high capacity disk drive systems, as is well-known in the art. Accordingly, virtual "audio tapes" appear the same as physical tapes to applications, allowing the use of many existing cartridge tape storage, retrieval and archival applications. Further, while the upper-limit of a physical tape cartridge may be a few hundred megabytes, a virtual tape server **662** can be configured to provide considerably larger "tape" capacity. Mount-time is near-zero for a virtual tape and the data is available immediately. Also, while traditional physical tape systems have to read a tape from the beginning, moving sequentially through the files on the tape, a virtual drive can randomly access data at hard-disk speeds, providing tape I/O at disk access speeds.

Additionally shown in FIG. 6, a sound processing firmware module of certain embodiments accesses a database **670** of sound signatures **660** and compares the received signal with the entries in the database to characterize or identify sounds in the received signal. In another embodiment, the sound processing module generates and/or accesses a database **670** of sound signatures specific to a patient, or specific to a particular type of patient (e.g., male/female, pediatric/adult/geriatric, etc.). Samples from a person may be recorded and used to generate the sound signatures. In some embodiments, certain signal characteristics are used to identify particular sounds or classes of sounds. For example, in one embodiment, signal deviations of relatively high amplitude and or sharp slope may be identified by the sound processing module. Sounds identified in various embodiments by the sound processing module include, but are not limited to, breathing, speech, choking, swallowing, spasms such as larynx spasms, coughing, gasping, etc.

Once the sound processing module characterizes a particular type of sound, the acoustic monitoring system can, depending on the identified sound, use the characterization to generate an appropriate response. For example, the system may alert the appropriate medical personnel to modify treatment. In one embodiment, medical personnel may be alerted via an audio alarm, mobile phone call or text message, or other appropriate means. In one example scenario, the breathing of the patient can become stressed or the patient may begin to choke due to saliva, mucosal, or other build up around an endotracheal tube. In an embodiment, the sound

processing module can identify the stressed breathing sounds indicative of such a situation and alert medical personnel to the situation so that a muscle relaxant medication can be given to alleviate the stressed breathing or choking.

According to some embodiments, acoustic sensors described herein can be used in a variety of other beneficial applications. For example, an auscultation firmware module may process a signal received by the acoustic sensor and provide an audio output indicative of internal body sounds of the patient, such as heart sounds, breathing sounds, gastrointestinal sounds, and the like. Medical personnel may listen to the audio output, such as by using a headset or speakers. In some embodiments the auscultation module allows medical personnel to remotely listen for patient diagnosis, communication, etc. For example, medical personnel may listen to the audio output in a different room in a hospital than the patient's room, in another building, etc. The audio output may be transmitted wirelessly (e.g., via Bluetooth, IEEE 802.11, over the Internet, etc.) in some embodiments such that medical personnel may listen to the audio output from generally any location.

FIGS. 7A-B illustrate sound processing embodiments **701**, **702** for generating an audio output for an acoustic sensor. As shown in FIG. 7A, in one embodiment, acoustic sensor data is A/D converted **710**, down-sampled with a decimation filter **720** and compressed **730**. The compressed audio data **732** is transmitted to a monitor, which decompresses the data **740** and outputs it to a speaker **742** or similar audio transducer. However, compressed audio data **732** from a physiological acoustic sensor has too high a bit rate to transmit over monitor data channels shared with other physiological processors or patient networks shared by multiple patient monitors all communicating physiological parameters, waveforms and other real-time medical data. Acoustic sensor data rates are described in further detail with respect to FIG. 9, below.

As shown in FIG. 7B, an envelope-based sound processing **702** embodiment advantageously allows respiration-related acoustic data to be transmitted at significantly reduced data rates compared with data compression so as to allow shared transmission over monitor data channels (**990** FIG. 9) and patient networks. Respiration-related acoustic data is A/D converted **710** and input to an envelope detector **750**. The detected envelopes are idealized and represented by a small number set or "tag" corresponding to each breath. In an embodiment, a breath tag represents the time-of-occurrence of the breath envelope peak for each inspiration and expiration cycle. These breath tags **760** are then transmitted over standard multiple parameter patient monitor data channels and/or patient networks. At the receiving end, a patient monitor, multiple patient monitoring system or like monitoring device synthesizes the envelopes **770** from the breath tags **760** according to the respiration rate (RR). The envelopes **770** are then filled with white noise **780** so as to simulate the original respiration acoustic data **782**.

FIGS. 8A-C further illustrate envelope processing for acoustic sensor data. FIG. 8A illustrates a representative acoustic signal **801** derived by a neck sensor detecting vibrations resulting from tracheal air flow during respiration. A breath sound **810** has an envelope **820** "pulse" corresponding to either inhalation or exhalation. An envelope detector **750** (FIG. 7B) generates breath tags that numerically describe the envelope **820**. As shown in FIG. 8B, in one embodiment, breath tags describe an idealized envelope **830**. For example, a breath tag may be an amplitude value and a duration value for each idealized pulse. In other embodiments, a breath tag may include leading/trailing slope values for a pulse **830**. As shown in FIG. 8C, in other embodiments, breath tags include

detected envelope features **842**, **843**, **844** that are characteristic of known acoustically-related phenomena such as wheezing or coughing, as examples. At a receiving device, envelop synthesis **770** (FIG. 7B) reproduces an envelope **830**, **840** and fills the envelope with an artificial waveform, such as white noise. This reconstructed or simulated breath signal is then output to a speaker or similar device. In other embodiments, breath tags are transmitted over a network to a remote device, which reconstructs breathing waveforms from the breath tags in like manner.

In various other embodiments, acoustic breathing waveforms are detected by an acoustic sensor, processed, transmitted and played on a local or remote speaker or other audio output from actual (raw) data, synthetic data and artificial data. Actual data may be compressed, but is a nearly complete or totally complete reproduction of the actual acoustic sounds at the sensor. Synthetic data may be a synthetic version of the breathing sound with the option of the remote listener to request additional resolution. Artificial data may simulate an acoustic sensor sound with minimal data rate or bandwidth, but is not as clinically useful as synthetic or actual data. Artificial data may be, for example, white noise bursts generated in sync with sensed respiration. Synthetic data is something between actual data and artificial data, such as the acoustic envelope process described above that incorporates some information from the actual sensor signal. In an embodiment breath sounds are artificially hi/lo frequency shifted or hi/lo volume amplified to distinguish inhalation/exhalation. In an embodiment, dual acoustic sensors placed along the neck are responsive to the relative time of arrival of tracheal sounds so as to distinguish inhalation and exhalation in order to appropriately generate the hi/lo frequency shifts. Raw and compressed acoustic respiration data is described with respect to FIG. 9, below. Artificial data "breath beeps" are described with respect to FIGS. 10A-B, below.

FIG. 9 illustrates a processor board **900** embodiment of an acoustic monitoring system that generates both optical and acoustic data. An optical portion has D/A converters **958** responsive to emitter drives **954** and an emitter control **950** so as to alternately activate optical sensor **902** LEDs of multiple wavelengths so as to illuminate blood perfused tissue. An A/D converter **960** and demodulator **964** are responsive to sensor **902** detectors so as to generate plethysmographic data **968** to a digital signal processor (DSP) **980**. Corresponding blood parameter algorithms **970** generate blood parameter outputs **972**, such as oxygen saturation (SpO_2), to a data channel **990**.

Also shown in FIG. 9, an acoustic portion has an A/D converter **910**, a decimation filter and mixer **920**, a coder/compressor **930** and a decoder/decompressor **935** so as to generate acoustic data to the DSP **980**. The A/D **910**, decimation filter/mixer **920** and a D/A converter **925** are responsive to an acoustic sensor **901** so as to generate an analog "raw" audio **909** output. In an embodiment, the A/D **910** is a 48 KHz, 16-bit, 2-channel variable gain device that provides higher resolution at lower signal amplitudes and lower resolution and higher signal amplitudes. In an embodiment, the decimation filter/mixer generates 2 KHz, 32-bit (64 Kbps) digitized raw audio **922**. Advantageously, the raw audio **909** is routed to a proximate amplifier/speaker **122** (FIG. 1). The digitized raw audio **922** is also input to the coder/compressor **930**. A 3:1 (approx.) compression generates a 20 Kbps compressed (digitized) audio **908** output. The compressed audio **908** is immediately input into a decoder/decompressor **935** for use by acoustic algorithms **940** to generate respiration rate (RR) and breath tag **942** outputs to a data channel **990**, as described above, among other acoustic-related parameters. Advantageously, the compression and immediate decompression of

the digitized raw audio **922** provides a compressed audio output **908** that can be stored and retrieved for accurate offline reproduction and troubleshooting of device behavior. Also, the compressed audio output **908** can be advantageously transmitted via Wi-Fi or other communication links to remote locations for processing and patient analysis.

FIGS. 10A-B illustrate a "respiration beep" embodiment **1001** for communicating reduced-rate respiration data over relatively low bandwidth monitor data channels and patient networks. As shown in FIG. 10A, in some situations, acoustic respiration data **1000** presents an inspiration (I) **1010** pulse relatively closely followed by an expiration (E) **1020** pulse, where each I/E pair is separated by a relatively longer pulseless interval. That is, these I/E pairs are relatively easily distinguished. As such, I/E pairs can be transmitted as simply time-of-occurrence values.

As shown in FIG. 10B, at an inspiration time **1062**, a high (HI) frequency tone **1064** is generated. At an expiration time **1062**, a low (LO) frequency tone **1064** is generated. A mixer **1050** combines colored noise **1042** with the HI/LO tones **1064** to generate higher-pitched followed by lower-pitched noise pulses representative of the original acoustic waveform **1000**. These respiration "beeps" are roughly analogous to pulse oximeter-generated "beeps" that coincide with optical sensor detected arterial blood pulses. In an advantageous embodiment, a processor board **900** (FIG. 9) having optical and acoustic sensors generates simultaneously occurring respiration beeps and pulse beeps, where the pulse beep tone is easily distinguished from the respiration beep HI/LO noise pulses. These combined pulse/respiration beeps advantageously allow a care provider to "monitor" a patient's respiration and pulse by sound alone.

FIG. 11 illustrates a wireless physiological acoustic monitor **1100** embodiment, which is particular advantageous for out-patient applications, such as sudden infant death syndrome (SIDS) prevention and elder care. The monitor **1100** has a sensor section **1101** and a remote section **1102**. The sensor section **1101** has a sensor **1110**, a sensor interface **1120** and a communications element **1130**. In an embodiment, the sensor **1110** is an adhesive substrate integrated with a piezoelectric assembly and interconnect cable, such as described with respect to FIGS. 3A-B, above. The sensor interface **1120** provides power to and receives the sensor signal from the sensor piezo circuit, as described with respect to FIG. 4, above. The wireless communications element **1130** receives the sensor signal from the sensor interface **1120** and transmits the signal to the corresponding communications element **1140** in the remote section **1102**, which provides an amplified sensor signal sufficient to drive a small speaker. In an embodiment, the communications link **1160** conforms with IEEE 802.15 (Bluetooth).

A physiological acoustic monitoring system has been disclosed in detail in connection with various embodiments. These embodiments are disclosed by way of examples only and are not to limit the scope of the claims that follow. One of ordinary skill in art will appreciate many variations and modifications.

What is claimed is:

1. An acoustic monitoring system comprising:
 - an acoustic sensor configured to detect heart sounds from a patient;
 - an analog to digital converter configured to digitize an acoustic sensor signal generated from the acoustic sensor corresponding to the detected heart sounds from the patient;

13

a decimation filter and mixer configured to reduce the data rate of the digitized acoustic sensor signal and output a digitized raw audio signal; and
 a hardware processor configured to:
 receive the digitized raw audio signal generated from the acoustic sensor corresponding to the detected heart sounds from the patient;
 detect an envelope in the received acoustic sensor signal;
 convert the envelope into a tag representing idealized envelope;
 determine a heart rate from the digitized raw audio signal; and
 transmit the heart rate and the tag over a data channel in lieu of the digitized raw audio signal.

2. The acoustic monitoring system of claim 1, further comprising a monitoring device configured to reconstruct the detected heart sounds from the patient based on the transmitted tags.

3. The acoustic monitoring system of claim 1, wherein the hardware processor is further configured to generate an alarm based the determined heart rate.

4. The acoustic monitoring system of claim 1, wherein the heart sound comprises a heart beat.

5. The acoustic monitoring system of claim 1, wherein the hardware processor is configured to transmit a notification to a monitoring device, the notification indicating availability of heart sounds.

6. The acoustic monitoring system of claim 1, wherein the acoustic sensor is attached near a heart of the patient.

7. The acoustic monitoring system of claim 1, wherein the transmission of the plurality of breath tags is in response to a request for transmission received by the hardware processor.

8. The acoustic monitoring system of claim 1, wherein the transmission occurs over a wireless channel.

9. An acoustic monitoring system comprising:
 a hardware processor configured to:
 generate an audio signal based on an acoustic sensor signal received from an acoustic sensor corresponding to heart sounds from a patient;
 detect an envelope in the received acoustic sensor signal;
 convert the envelope into a tag representing idealized envelope; and

14

transmit the tag over a data channel in lieu of the audio signal.

10. The acoustic monitoring system of claim 9, wherein the hardware processor is further configured to:
 receive a request for transmission of a portion of the audio signal; and
 transmit the portion of the audio signal over the data channel responsive to the request.

11. The acoustic monitoring system of claim 10, wherein the portion is identified by an operator of a monitoring device.

12. The acoustic monitoring system of claim 10, wherein the portion is identified automatically based on a heart event.

13. The acoustic monitoring system of claim 9, wherein the hardware processor is further configured to calculate a heart rate from the audio signal.

14. The acoustic monitoring system of claim 9, wherein the tag numerically describes an envelope.

15. An acoustic monitoring method comprising:
 generating an audio signal based on an acoustic sensor signal received from an acoustic sensor corresponding to heart sounds from a patient;
 detecting an envelope in the received acoustic sensor signal;
 converting the envelope into a tag representing idealized envelope; and
 transmitting the tag over a data channel in lieu of the audio signal.

16. The acoustic monitoring method of claim 15, further comprising:
 receiving a request for transmission of a portion of the audio signal; and
 transmitting the portion of the audio signal over the data channel responsive to the request.

17. The acoustic monitoring method of claim 16, wherein the portion is identified by an operator of a monitoring device.

18. The acoustic monitoring method of claim 16, wherein the portion is identified automatically based on a heart event.

19. The acoustic monitoring method of claim 15, further comprising calculating a heart rate from the audio signal.

20. The acoustic monitoring method of claim 15, wherein the tag numerically describes an envelope.

* * * * *

UNITED STATES PATENT AND TRADEMARK OFFICE
CERTIFICATE OF CORRECTION

PATENT NO. : 9,370,335 B2
APPLICATION NO. : 14/522474
DATED : June 21, 2016
INVENTOR(S) : Ammar Al-Ali et al.

Page 1 of 1

It is certified that error appears in the above-identified patent and that said Letters Patent is hereby corrected as shown below:

On the title page

In column 2 (page 1, item 56) at line 3, Change "Aibert" to --Alibert--.

In column 1 (page 2, item 56) at line 28, After "Mather" insert --et al.--.

In column 1 (page 3, item 56) at line 41, Change "Pishney" to --Kiani--.

In column 2 (page 7, item 56) at line 35, Under Other Publications, Change "Sheete," to --Sheet,--.

In column 2 (page 7, item 56) at line 36, Under Other Publications, Change "WelchAllyn" to --Welch Allyn--.

In the drawings

Sheet 5 of 11 (Reference Numeral 535, FIG. 5) at line 1, Change "ASCULATION" to --AUSCULTATION--.

In the specification

In column 1 at line 40, Change "Dec. 30, 2009" to --Dec. 30, 2008--.

In column 9 at line 51, Change "and or" to --and/or--.

In the claims

In column 13 at line 21 (approx.), In Claim 3, change "based the" to --based on the--.

Signed and Sealed this
Twentieth Day of December, 2016



Michelle K. Lee
Director of the United States Patent and Trademark Office

专利名称(译)	生理声学监测系统		
公开(公告)号	US9370335	公开(公告)日	2016-06-21
申请号	US14/522474	申请日	2014-10-23
[标]申请(专利权)人(译)	梅西莫股份有限公司		
申请(专利权)人(译)	Masimo公司		
当前申请(专利权)人(译)	Masimo公司		
[标]发明人	AL ALI AMMAR LEE SUNG UK		
发明人	AL-ALI, AMMAR LEE, SUNG UK		
IPC分类号	A61B5/00 A61B7/00 A61B7/04 A61B5/08 G10L19/00		
CPC分类号	A61B7/003 A61B7/04 A61B5/0803 A61B5/0816 A61B5/082 A61B5/0823 A61B5/7225 A61B5/7278 A61B5/7405 A61B5/725 G10L19/00 A61B5/0004 A61B5/7415 A61B5/7232 A61B5/0022 A61B5/02416 A61B5/6822 A61B5/742 A61B5/746		
优先权	12/905036 2014-09-02 US 61/547007 2011-10-13 US 61/252099 2009-10-15 US 61/391098 2010-10-08 US		
其他公开文献	US20150045685A1		
外部链接	Espacenet USPTO		

摘要(译)

生理声学监测系统从声学传感器接收生理数据，对数据进行下采样以生成呼吸声音的原始音频并压缩原始音频。声学监测系统具有响应于人的气管声音的声学传感器信号。A/D转换器响应传感器信号以产生呼吸声数据。抽取滤波器和混频器将呼吸声音数据下采样到原始音频数据。编码器/压缩器从原始音频数据生成压缩音频数据。解码器/解压缩器将压缩的音频数据解码和解压缩成解压缩的音频数据。解压缩的音频数据用于实时生成呼吸相关参数。存储和检索压缩的音频数据，以便非实时地生成与呼吸相关的参数。比较实时和非实时参数以验证多个监视器之间的匹配结果。

