



US 20180039753A1

(19) **United States**

(12) **Patent Application Publication**

**Blair et al.**

(10) **Pub. No.: US 2018/0039753 A1**

(43) **Pub. Date: Feb. 8, 2018**

(54) **METHOD AND APPARATUS TO DETECT TRANSPONDER TAGGED OBJECTS AND TO COMMUNICATE WITH MEDICAL TELEMETRY DEVICES, FOR EXAMPLE DURING MEDICAL PROCEDURES**

*A61B 5/03* (2006.01)

*A61B 5/00* (2006.01)

*A61B 90/98* (2006.01)

(52) **U.S. Cl.**

CPC ..... *G06F 19/3418* (2013.01); *A61B 5/0002* (2013.01); *A61B 5/6887* (2013.01); *A61B 90/98* (2016.02); *A61B 5/031* (2013.01); *A61B 5/14551* (2013.01); *A61B 2017/00212* (2013.01)

(71) Applicant: **Covidien LP**, Mansfield, MA (US)

(72) Inventors: **William A. Blair**, San Diego, CA (US);  
**Bruce E. Barnes**, Escondido, CA (US);  
**David A. Poirier**, Escondido, CA (US)

(21) Appl. No.: **15/786,001**

(22) Filed: **Oct. 17, 2017**

**Related U.S. Application Data**

(62) Division of application No. 12/606,963, filed on Oct. 27, 2009, now Pat. No. 9,792,408.

(60) Provisional application No. 61/242,699, filed on Sep. 15, 2009, provisional application No. 61/222,847, filed on Jul. 2, 2009.

**Publication Classification**

(51) **Int. Cl.**

*G06F 19/00* (2006.01)

*A61B 5/1455* (2006.01)

(57)

**ABSTRACT**

The presence or absence of objects tagged with transponders may be determined in an environment in which medical procedures are performed via an interrogation and detection system which includes a controller and a plurality of antennas positioned along a patient support structure. The antennas may be positioned along an operating table, bed, mattress or pad, sheet, or may be positioned on a drape, or shade. Respective antennas may successively be activated to transmit interrogation signals. Multiple antennas may be monitored for responses from transponders to the interrogation signals. For example, all antennas other than the antenna that transmitted the most recent interrogation signal may be monitored. Antennas may be responsive to force, a signal indicative of such force being produced. A wireless physiological condition monitor may detect patient physiological conditions and wirelessly transmit signals indicative of such.

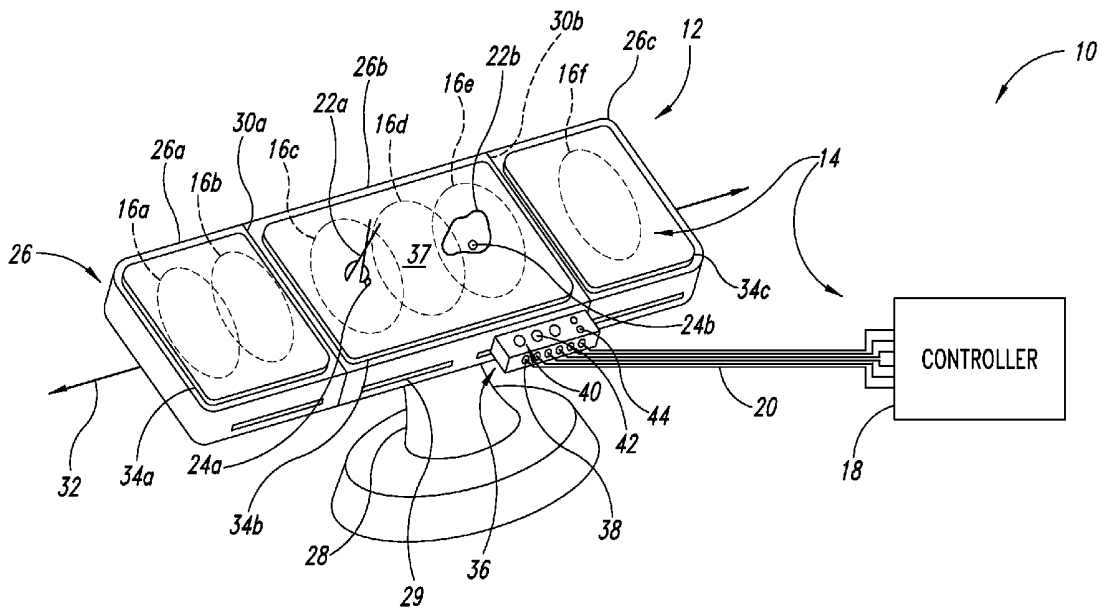

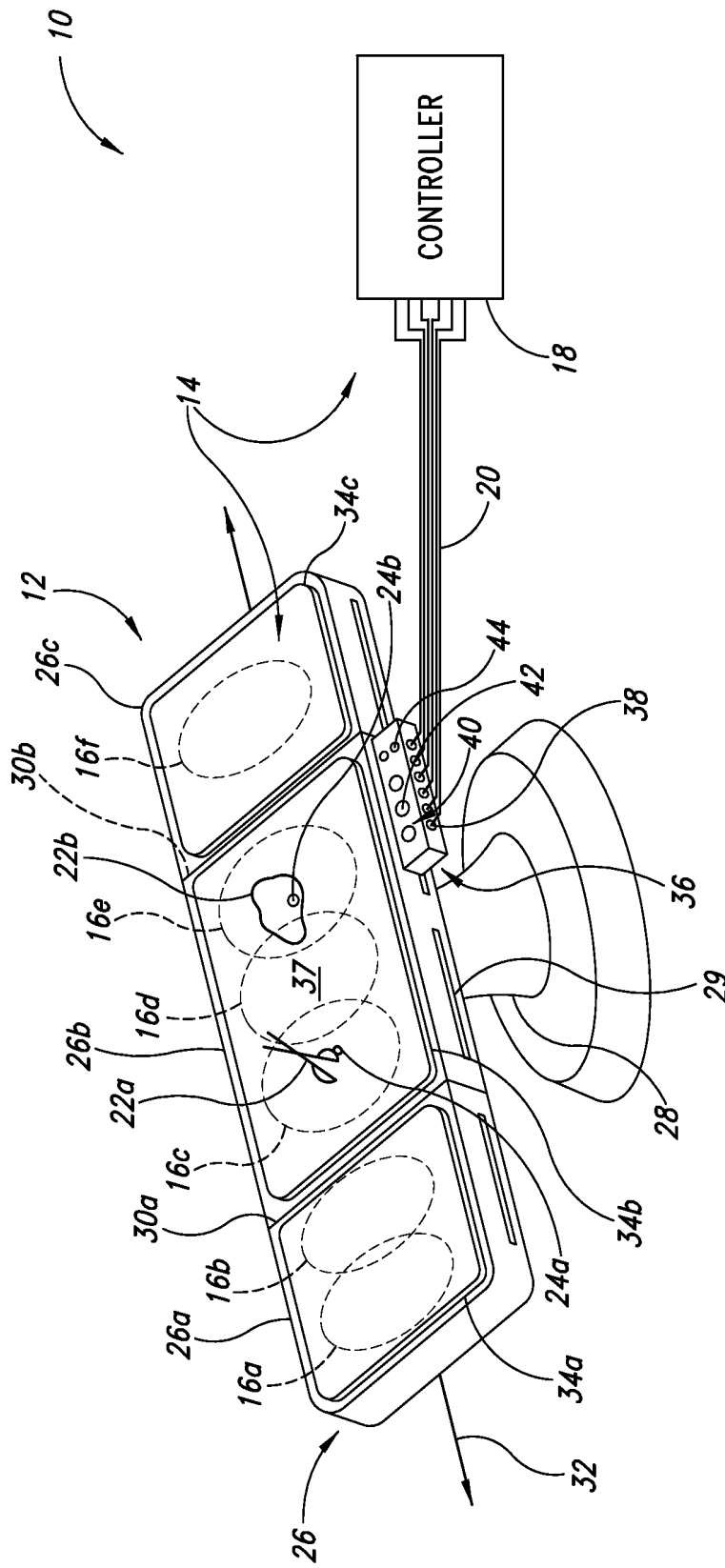

FIG. 1

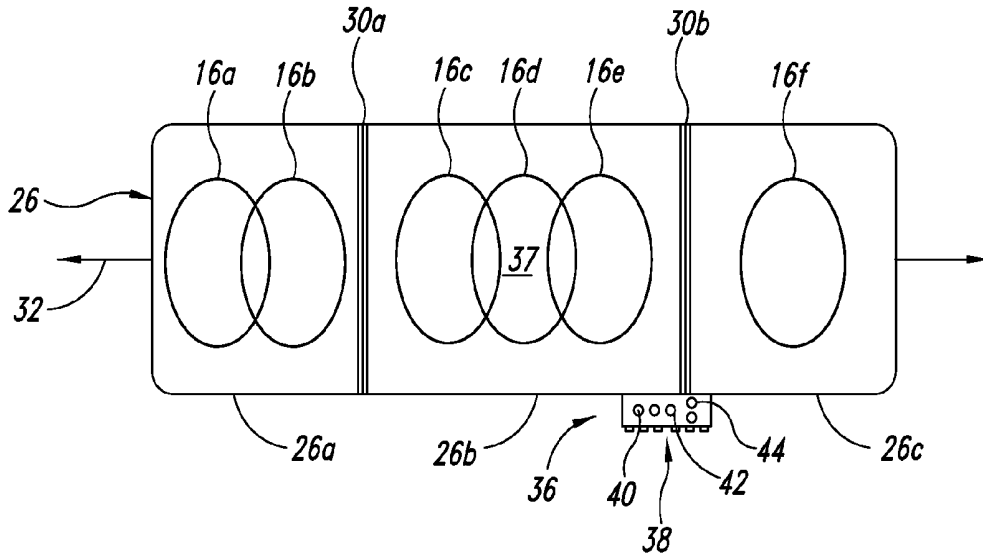

FIG. 2

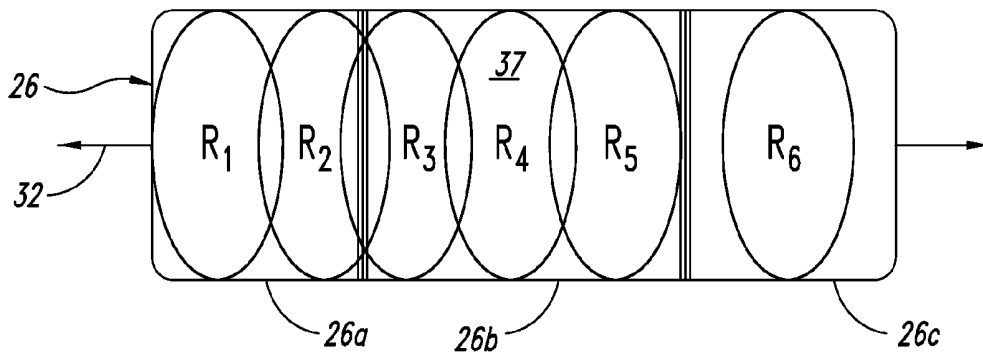

FIG. 3

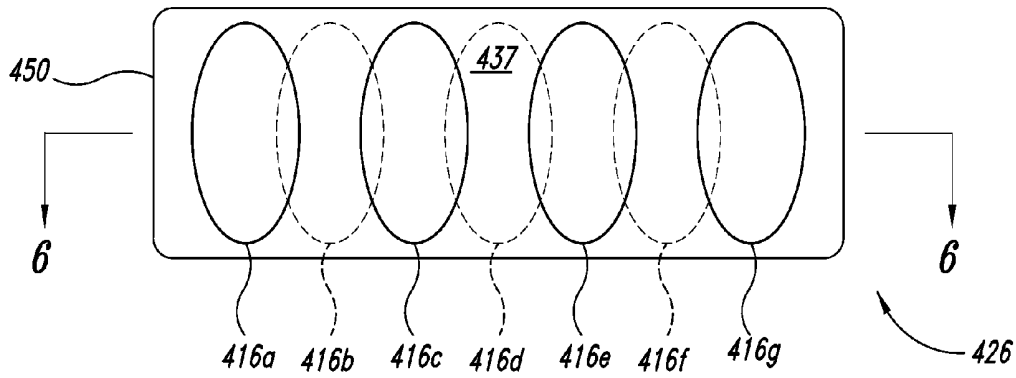

FIG. 4

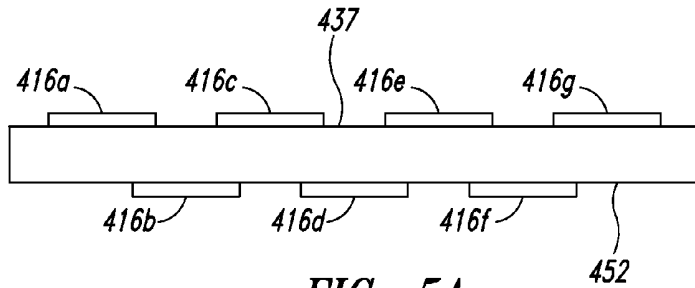

FIG. 5A

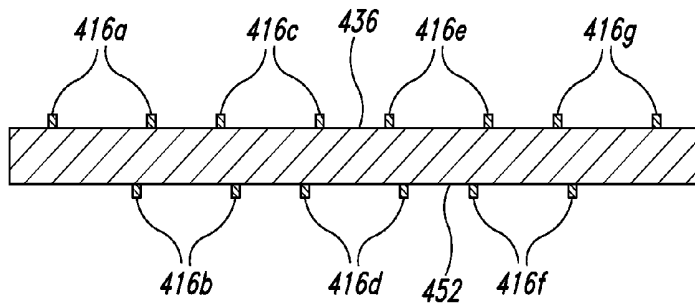

FIG. 5B

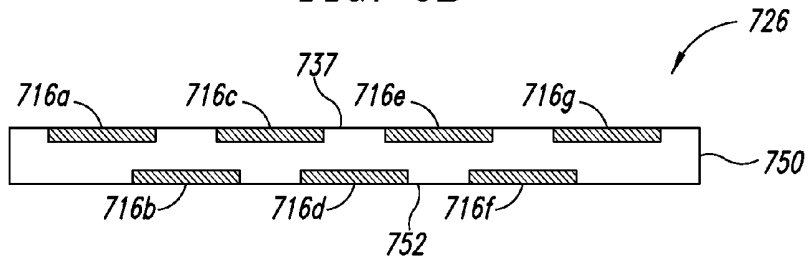
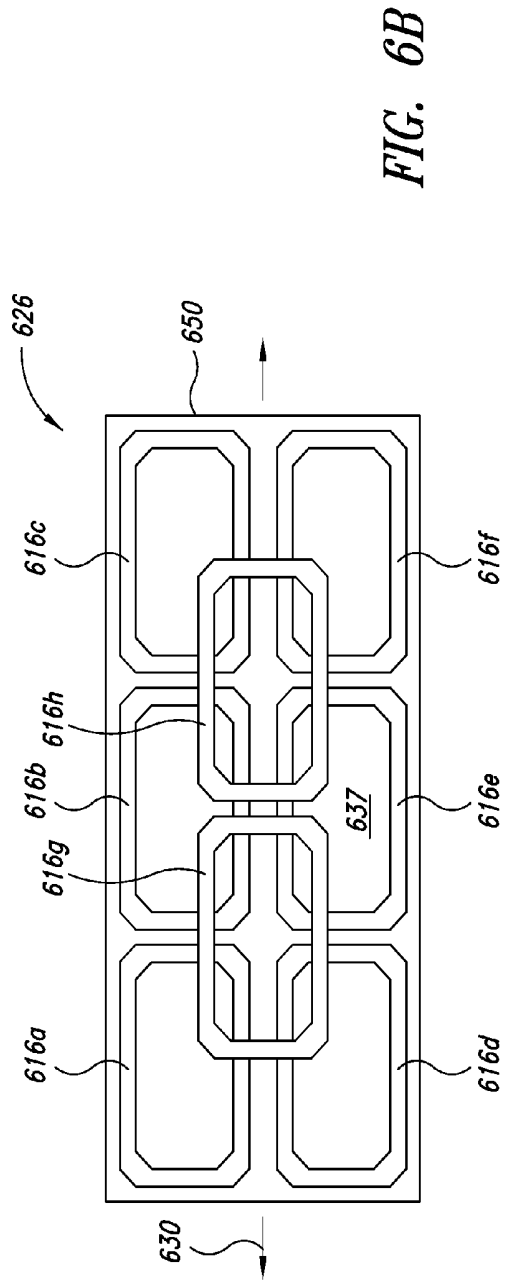
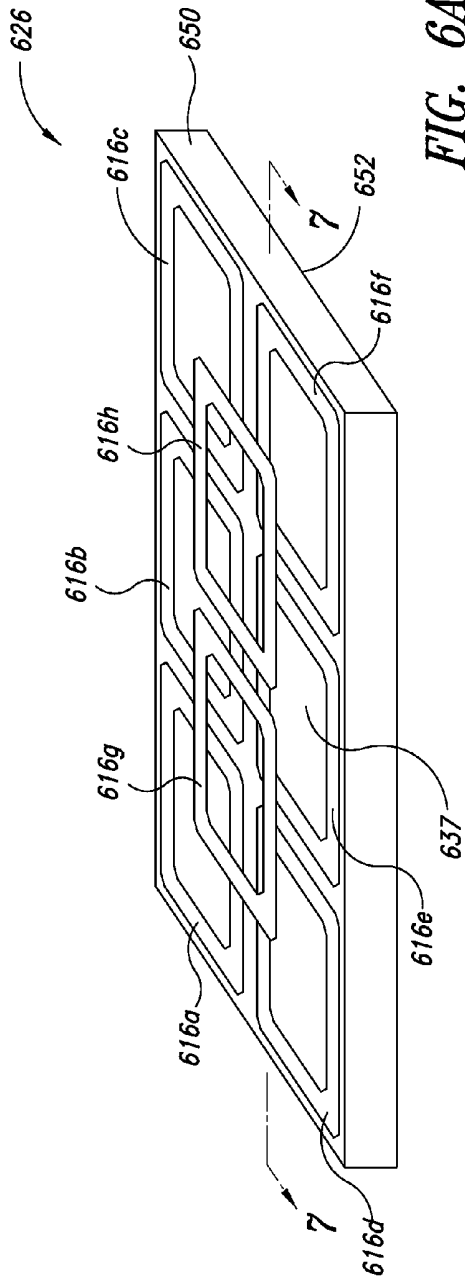

FIG. 7



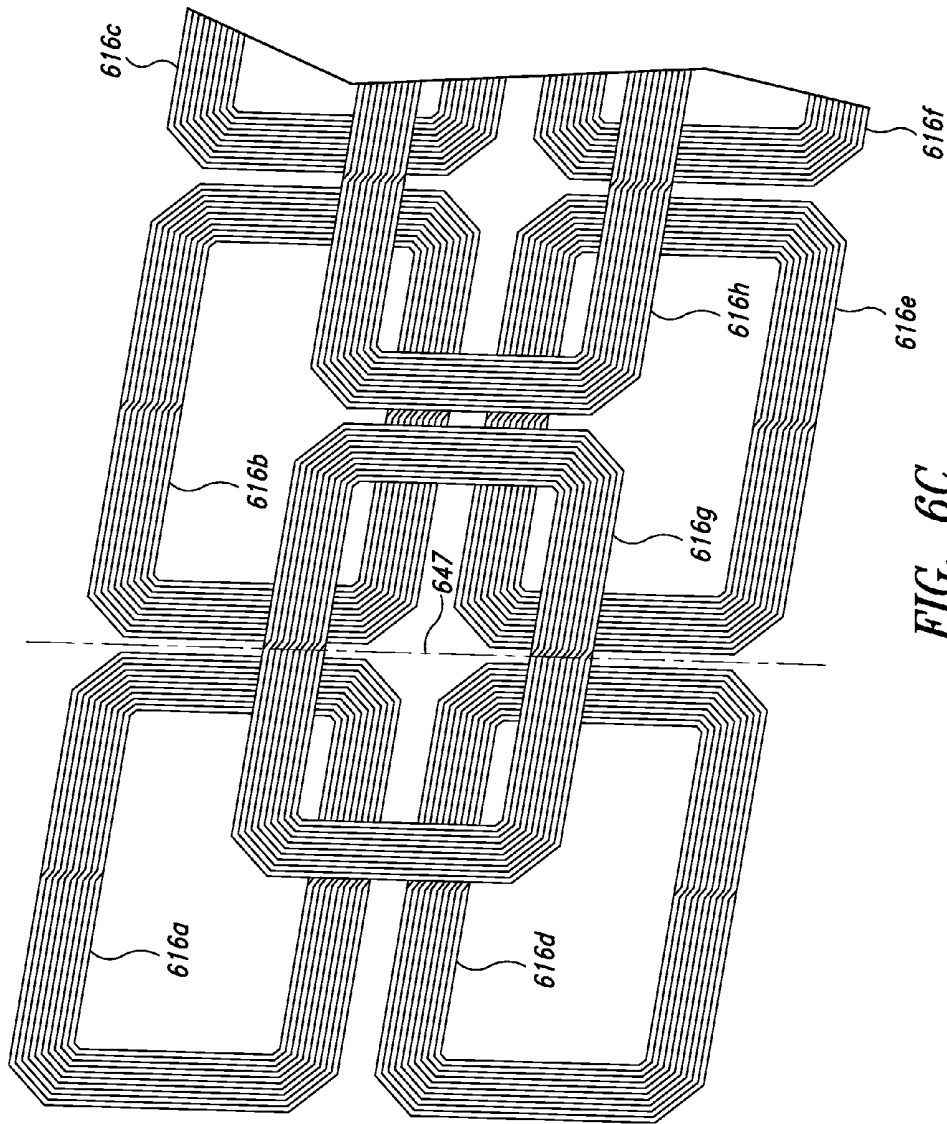

FIG. 6C

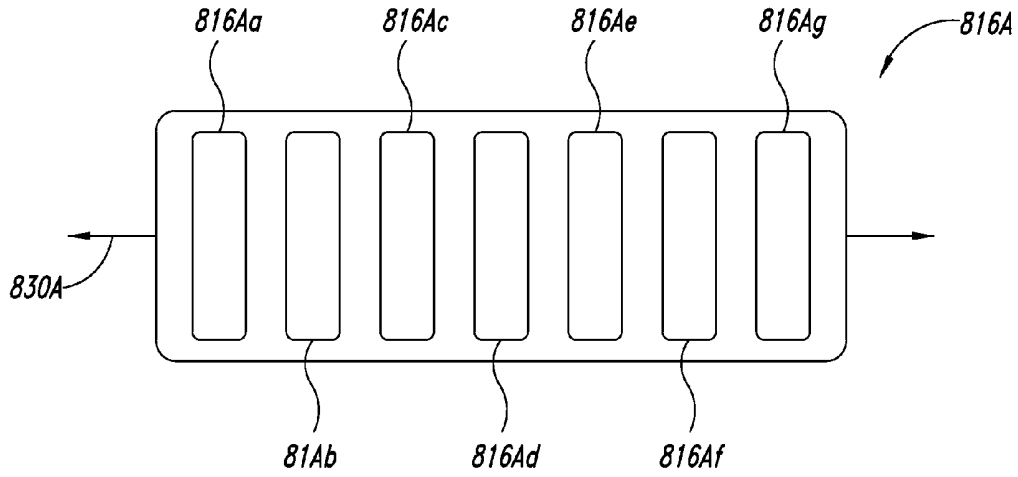

FIG. 8A

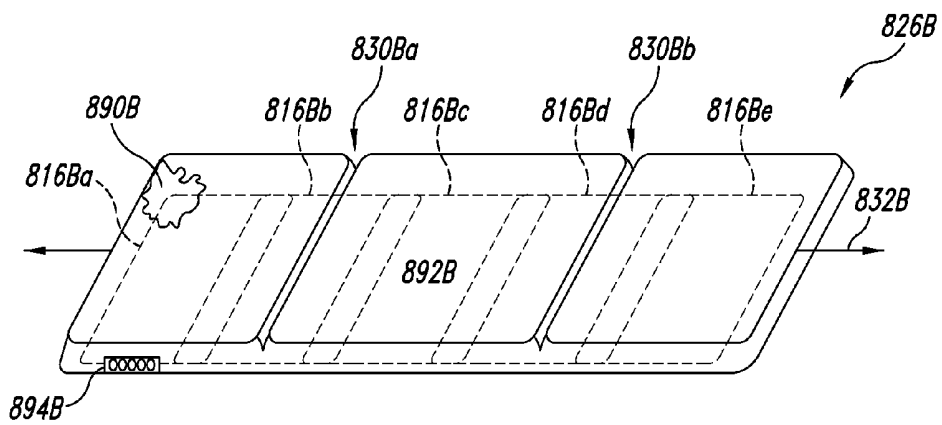

FIG. 8B

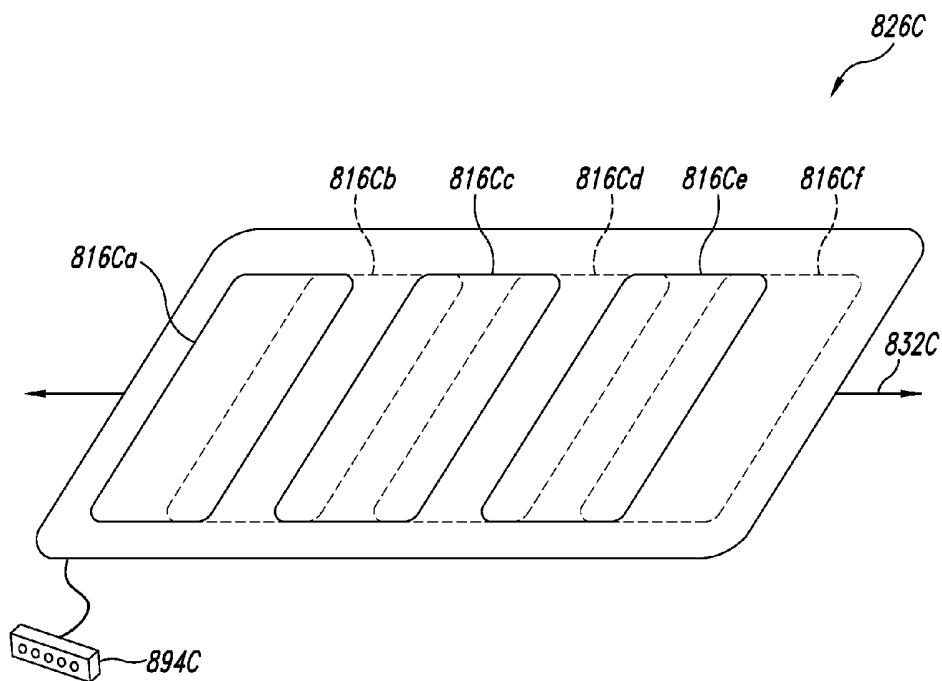

FIG. 8C

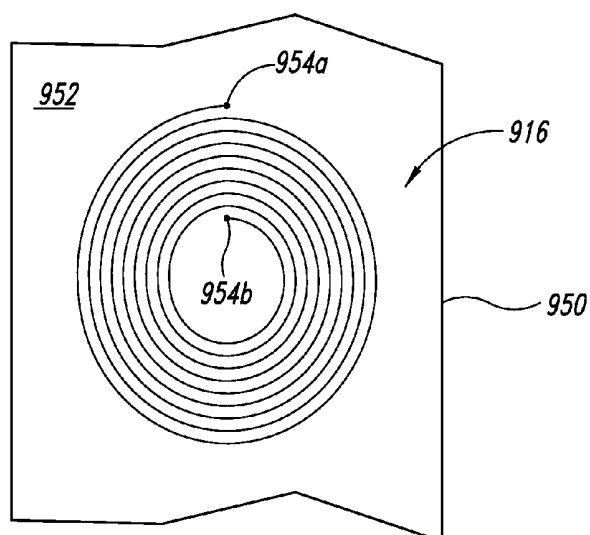

FIG. 9

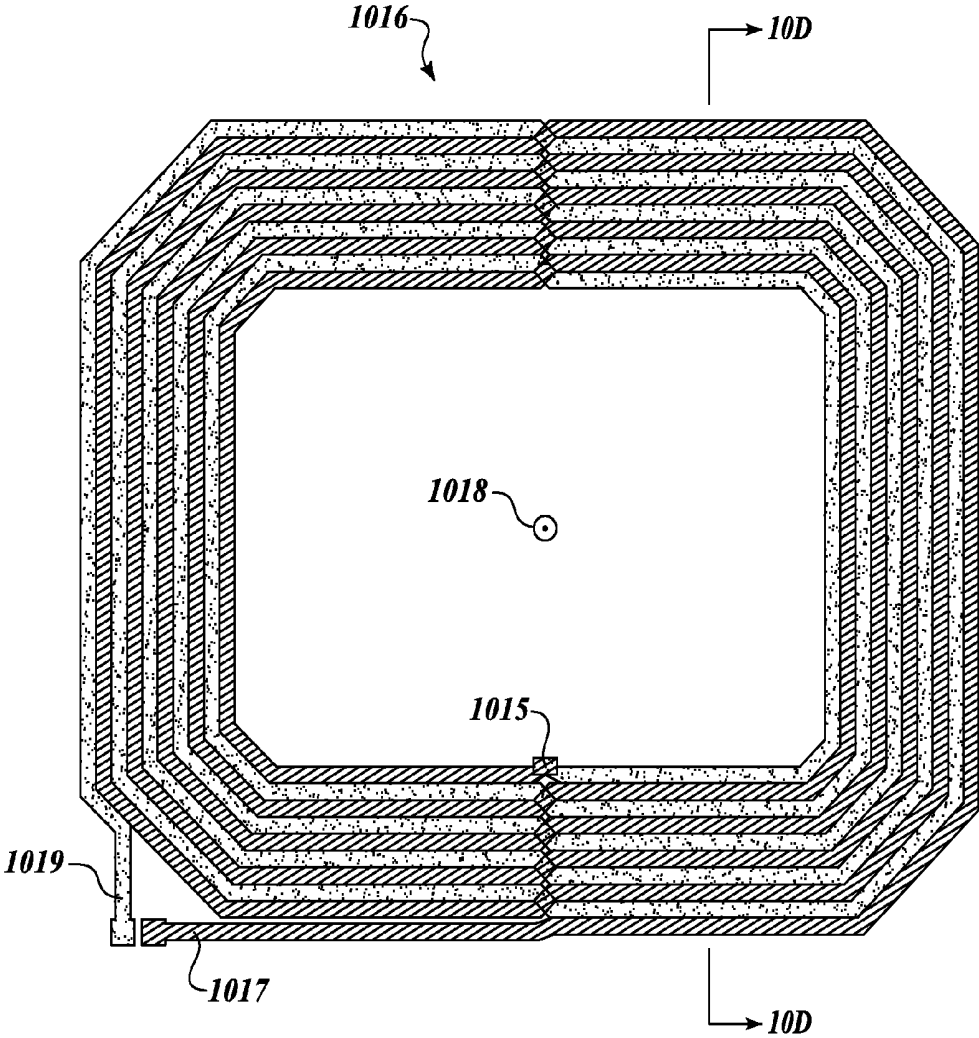

FIG. 10A

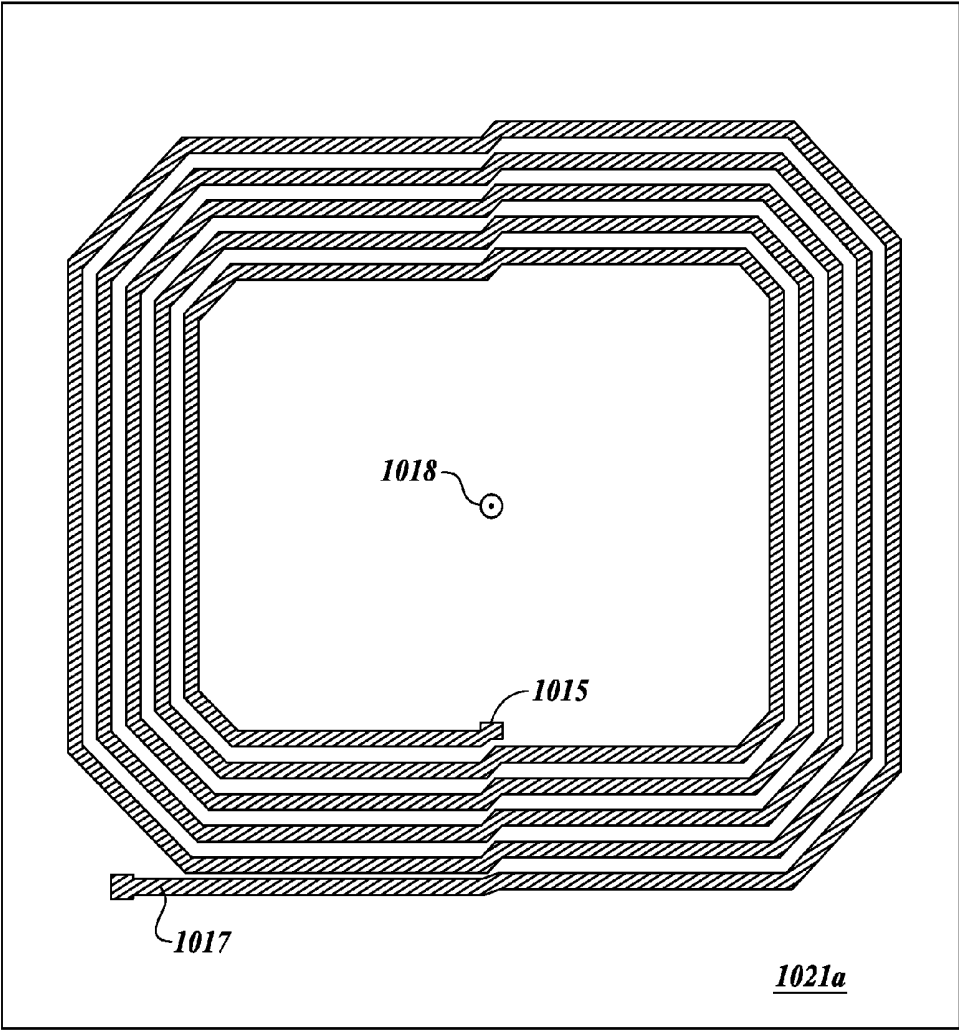

FIG. 10B

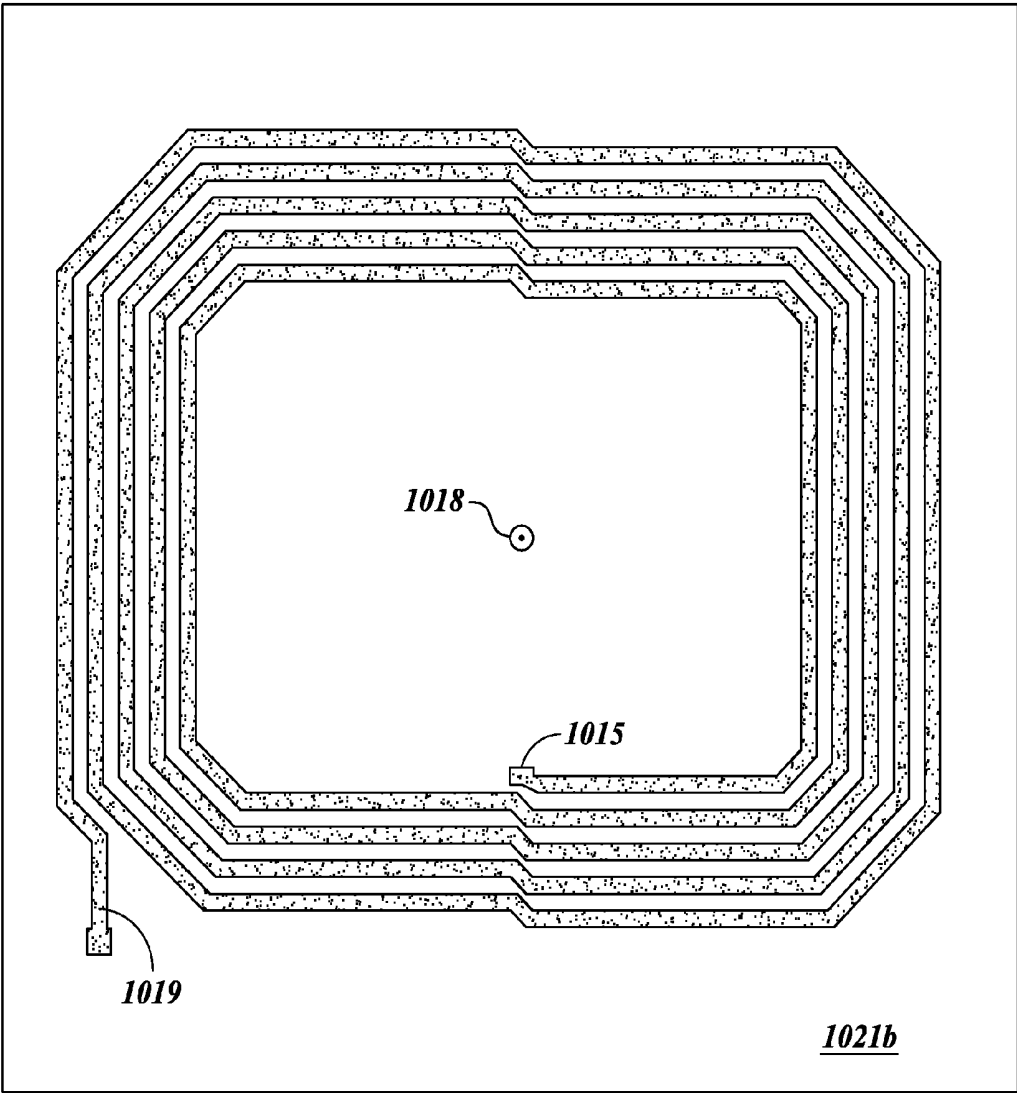

FIG. 10C

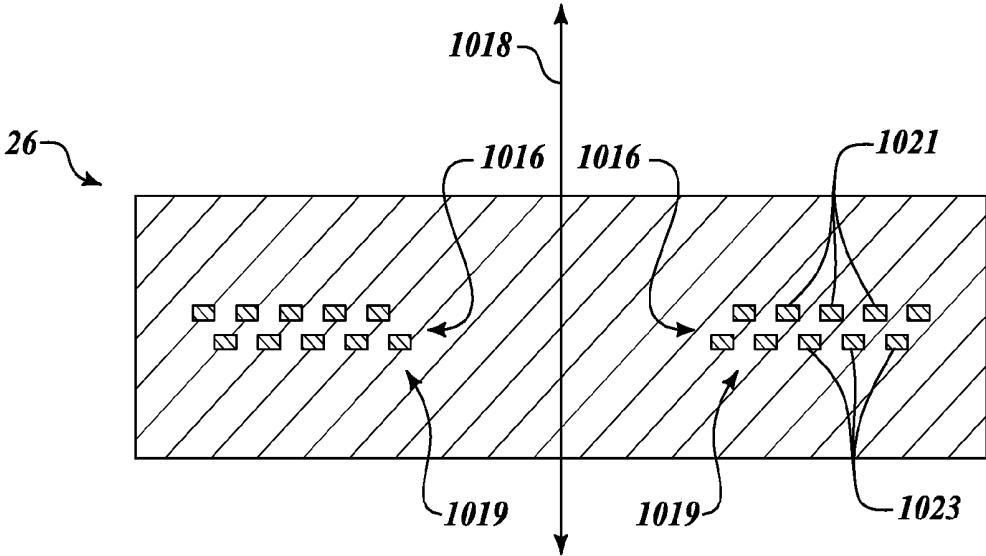

FIG. 10D

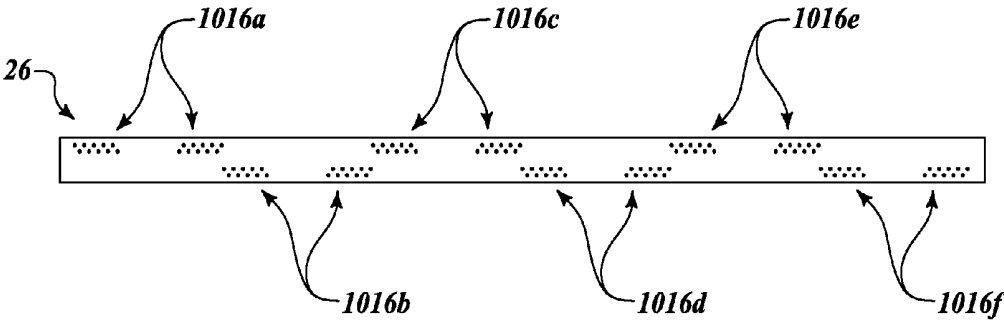
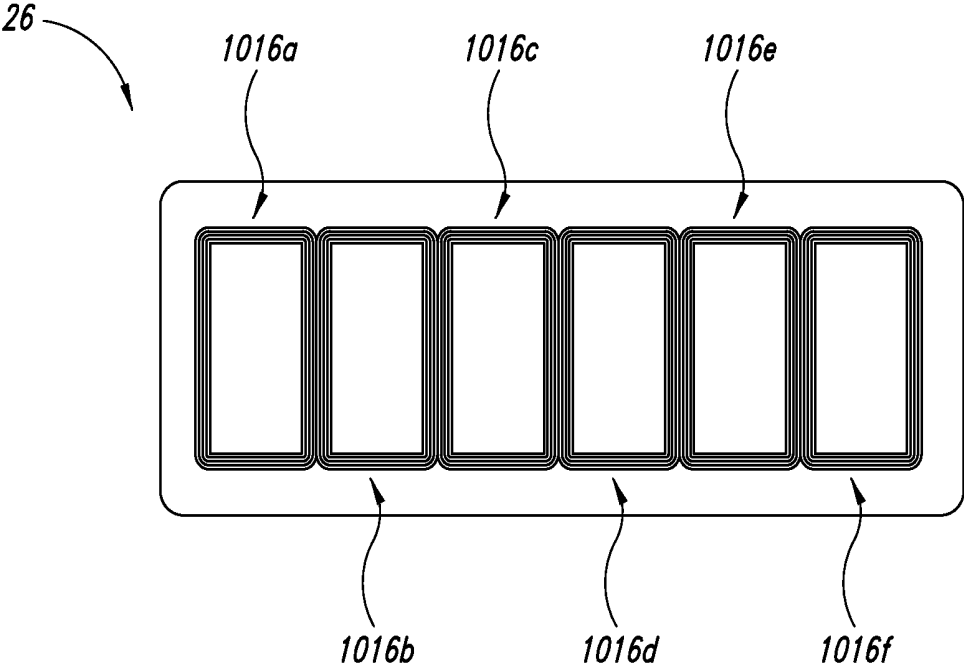

FIG. 10E



*FIG. 10F*

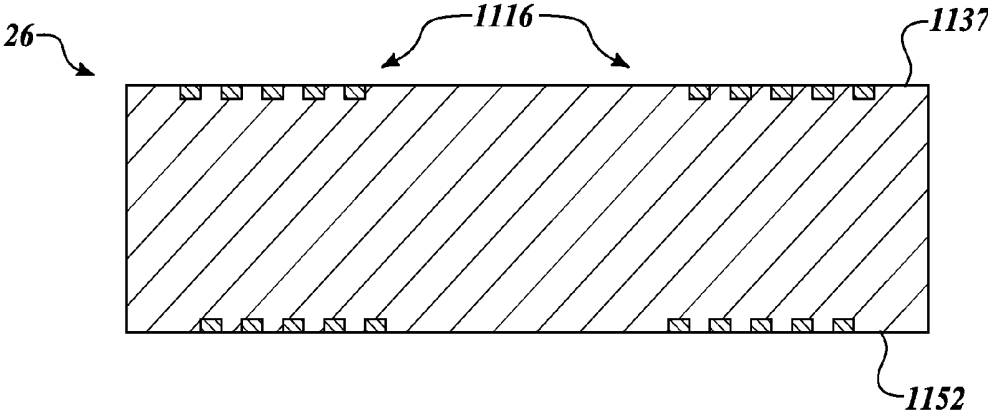

FIG. 11

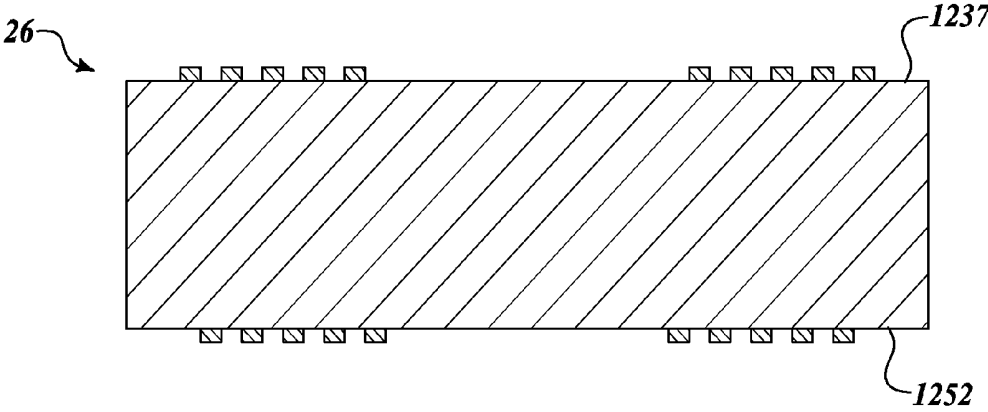

FIG. 12

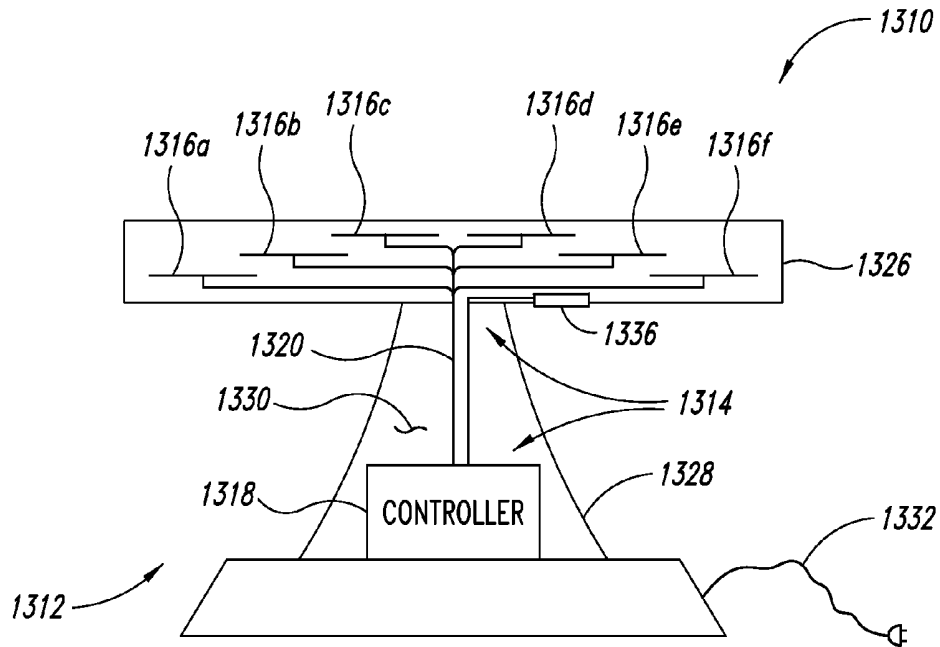

FIG. 13A

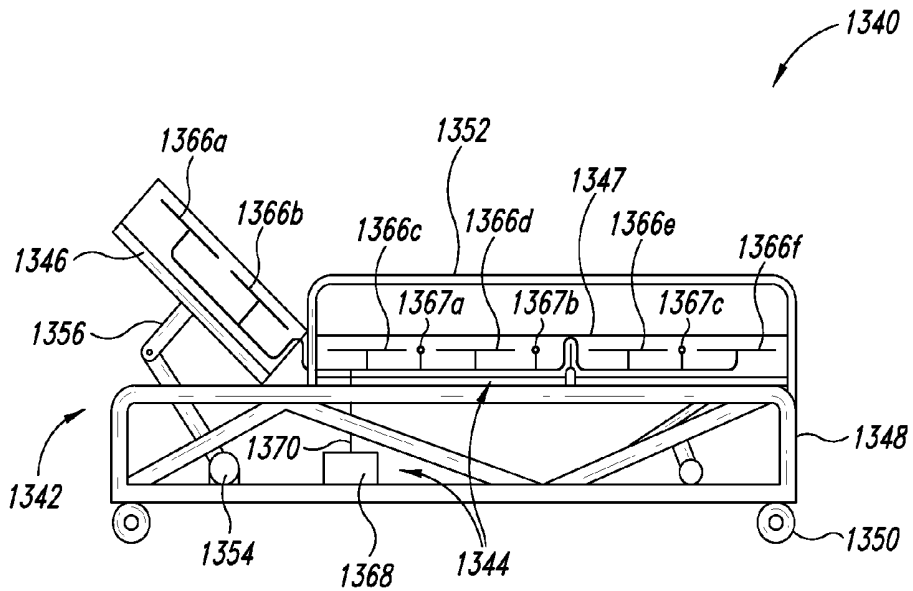

FIG. 13B

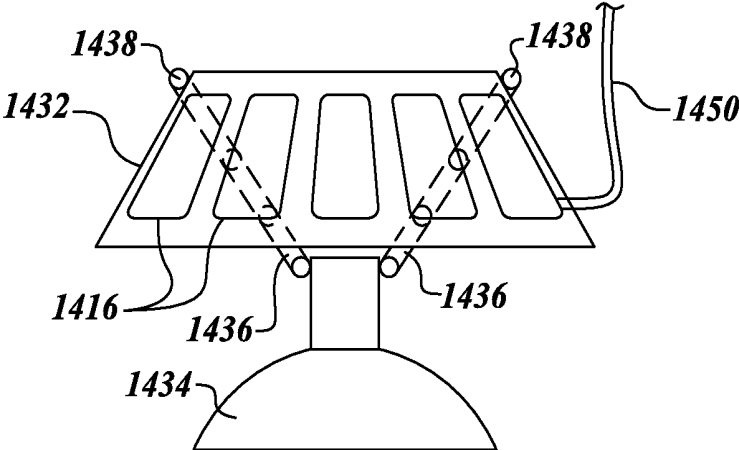

FIG. 14A

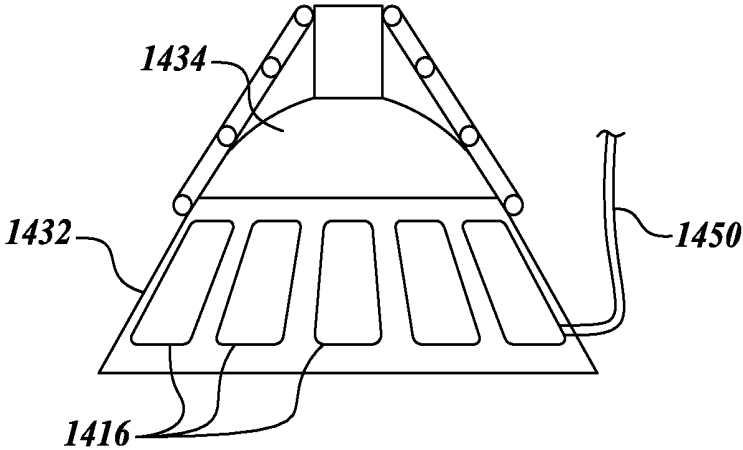

FIG. 14B

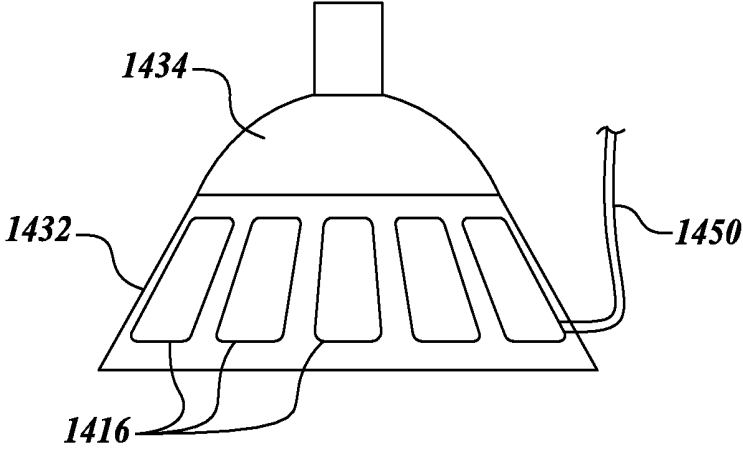

FIG. 14C

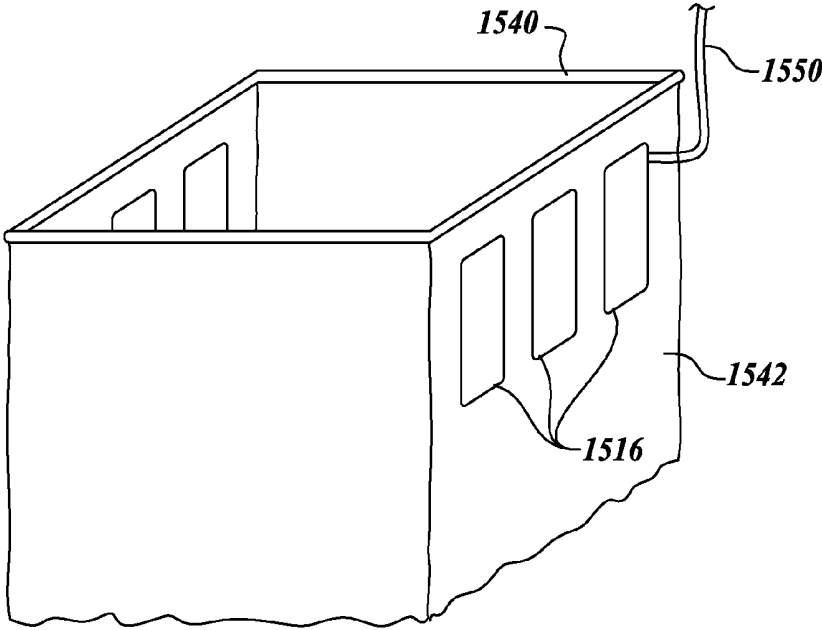

FIG. 15A

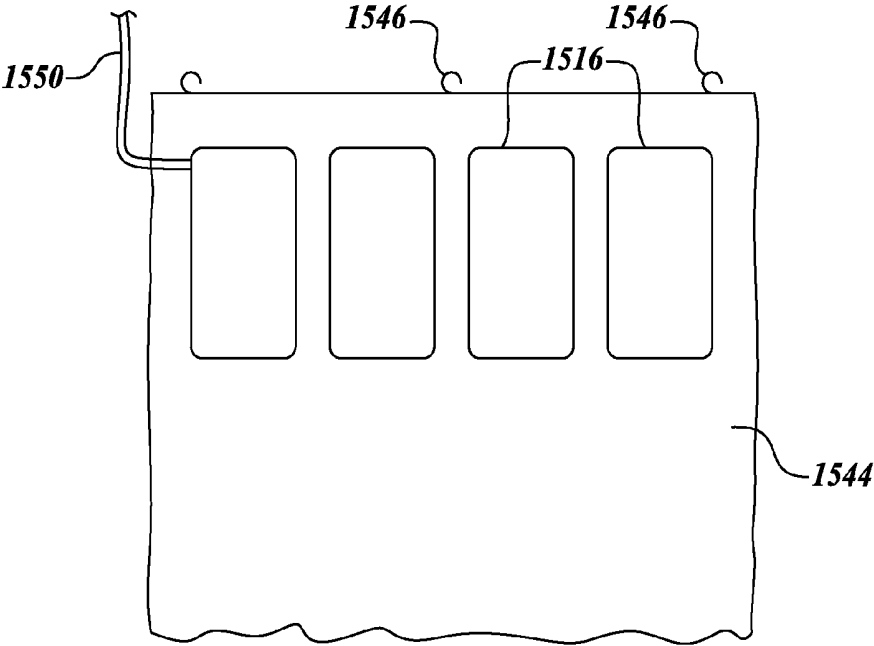

FIG. 15B

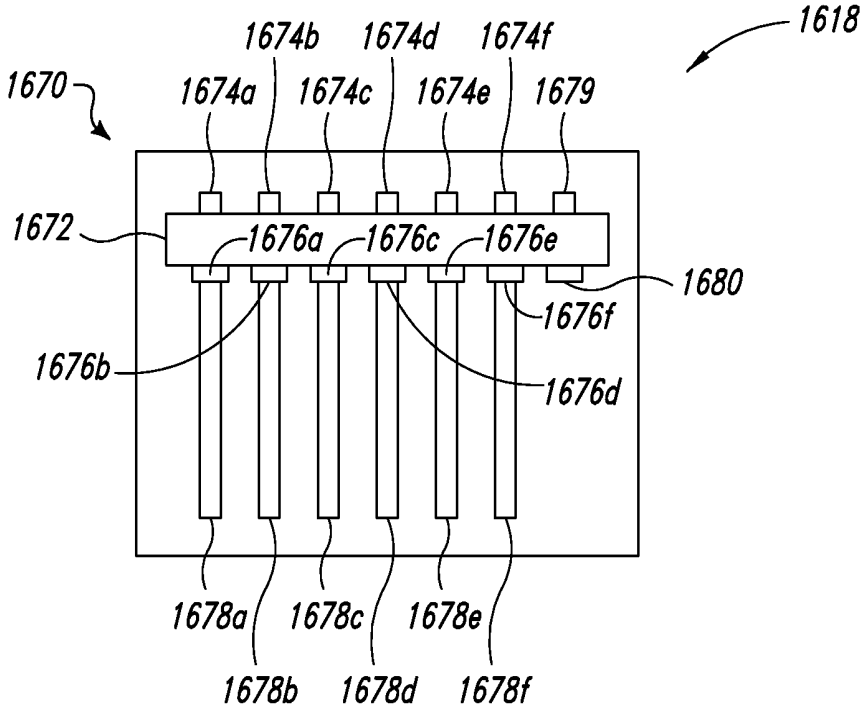

FIG. 16

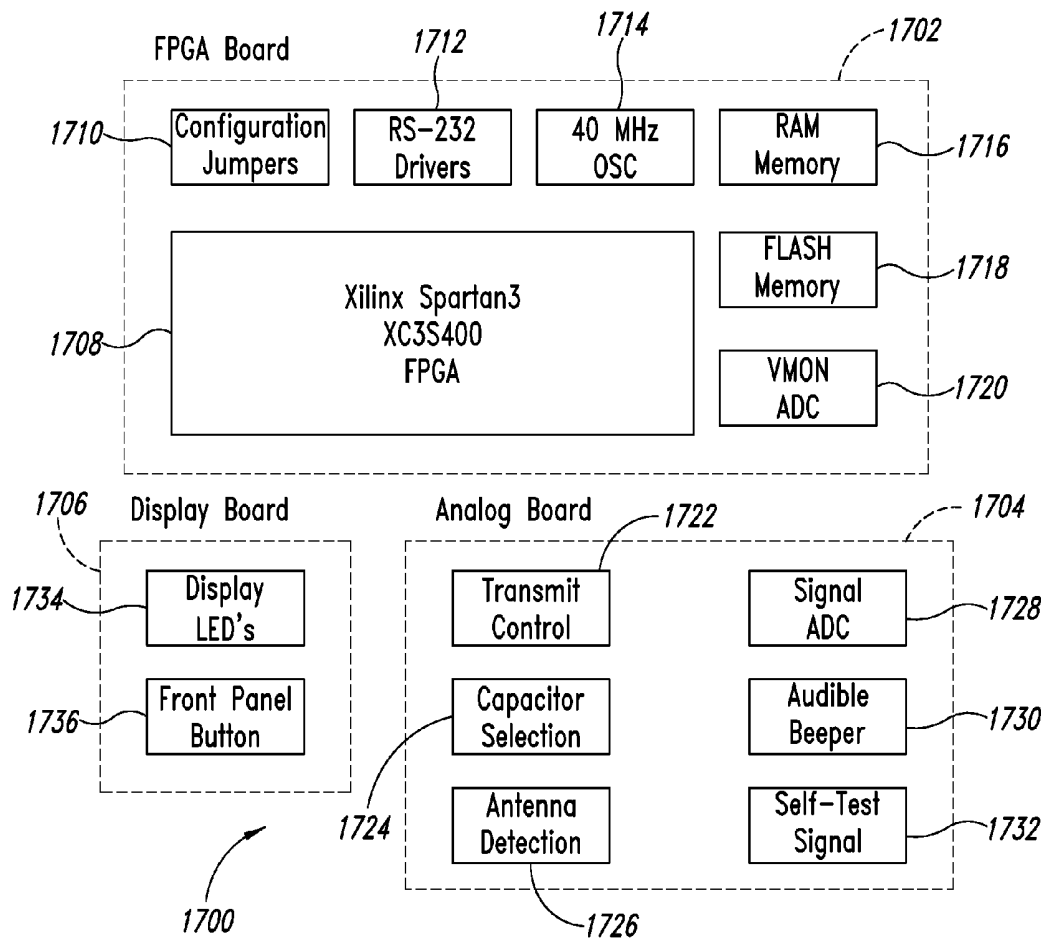

FIG. 17

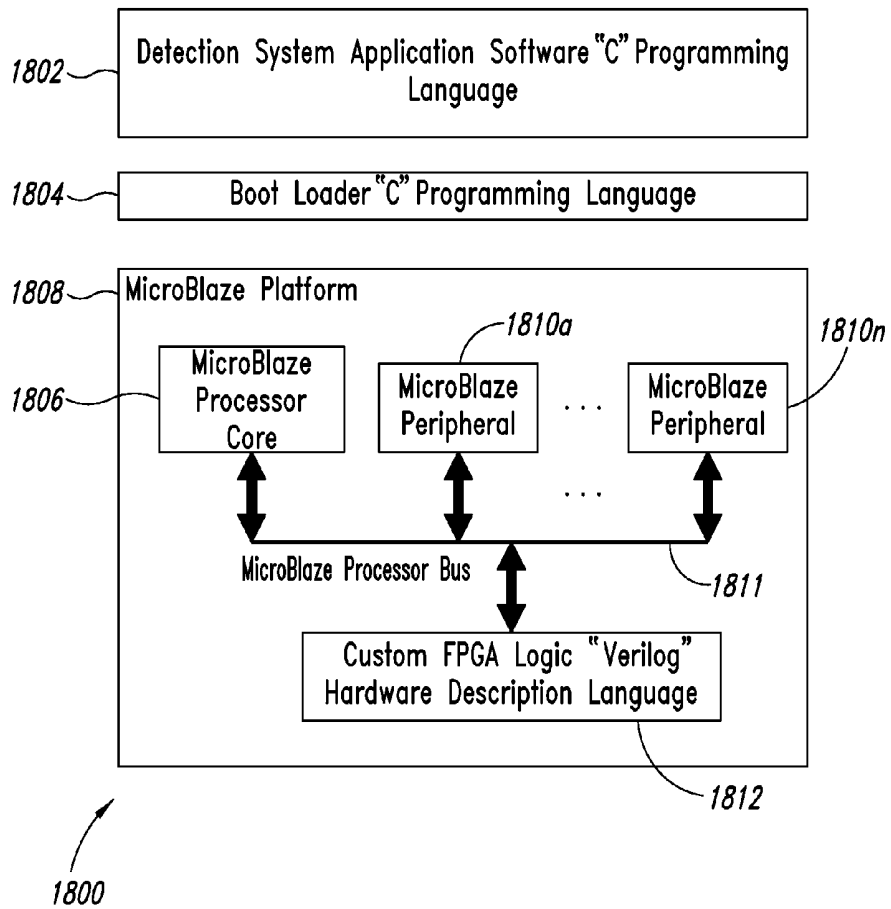

FIG. 18

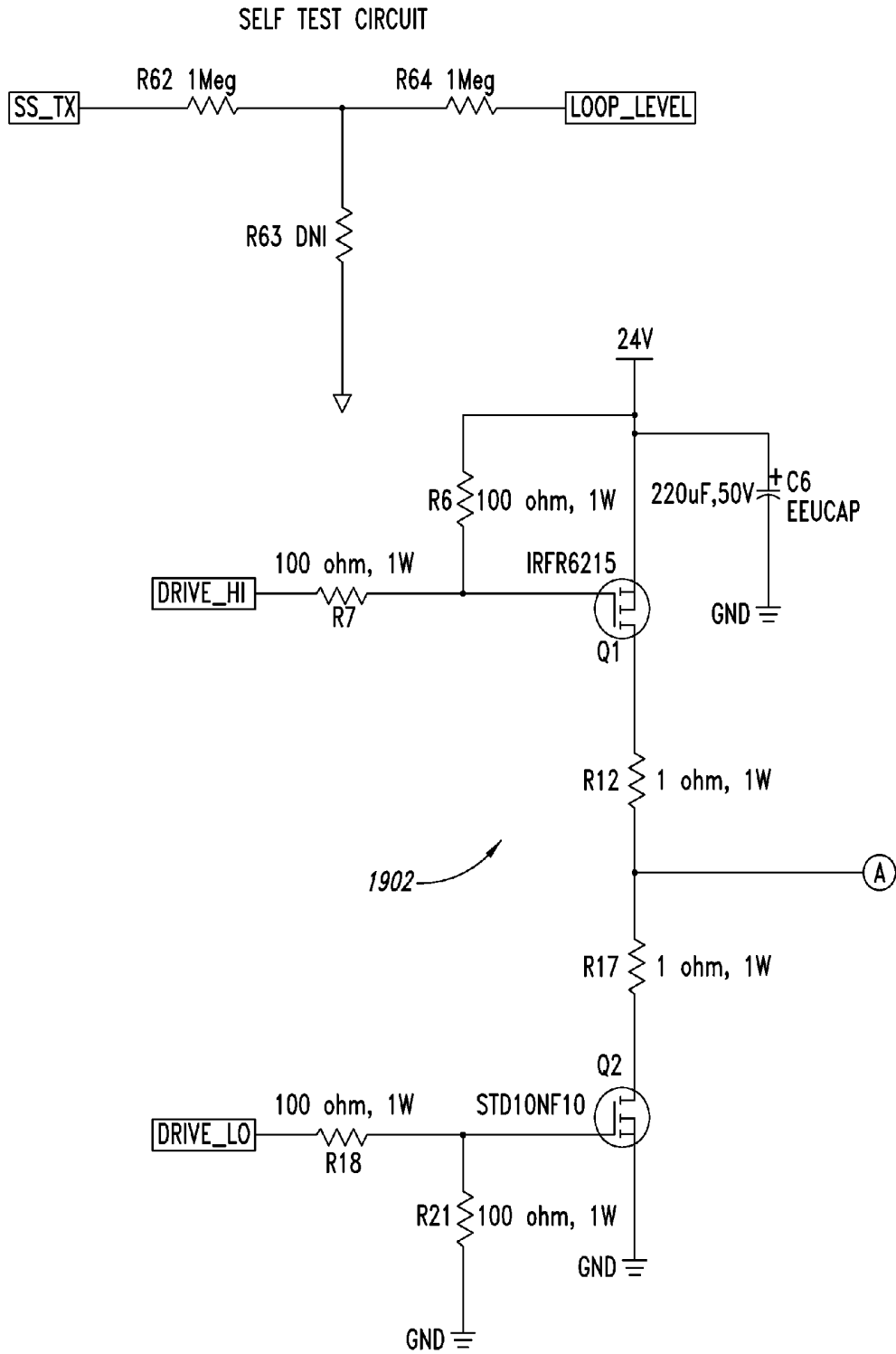

FIG. 19A



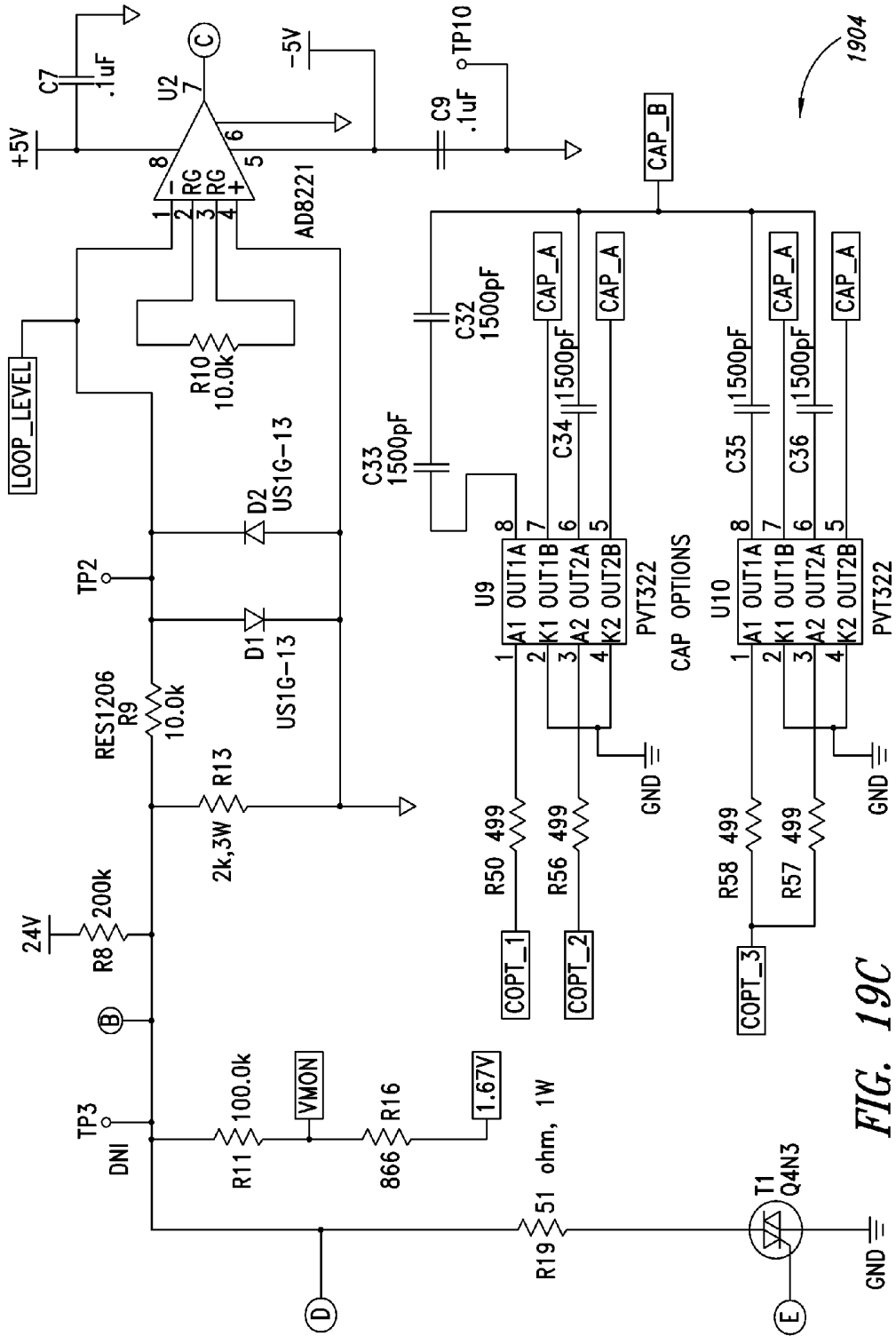

FIG. 19C

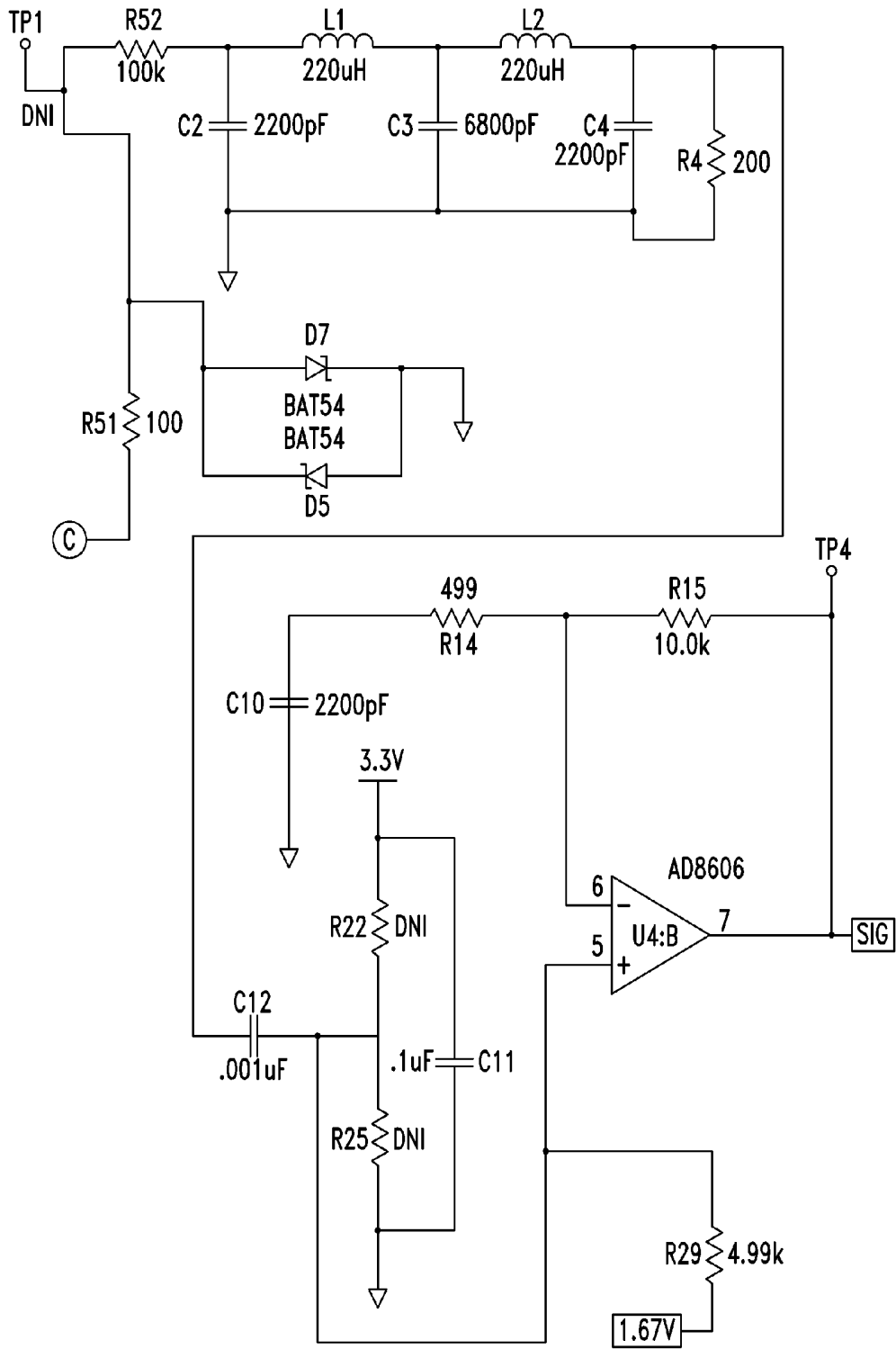

FIG. 19D

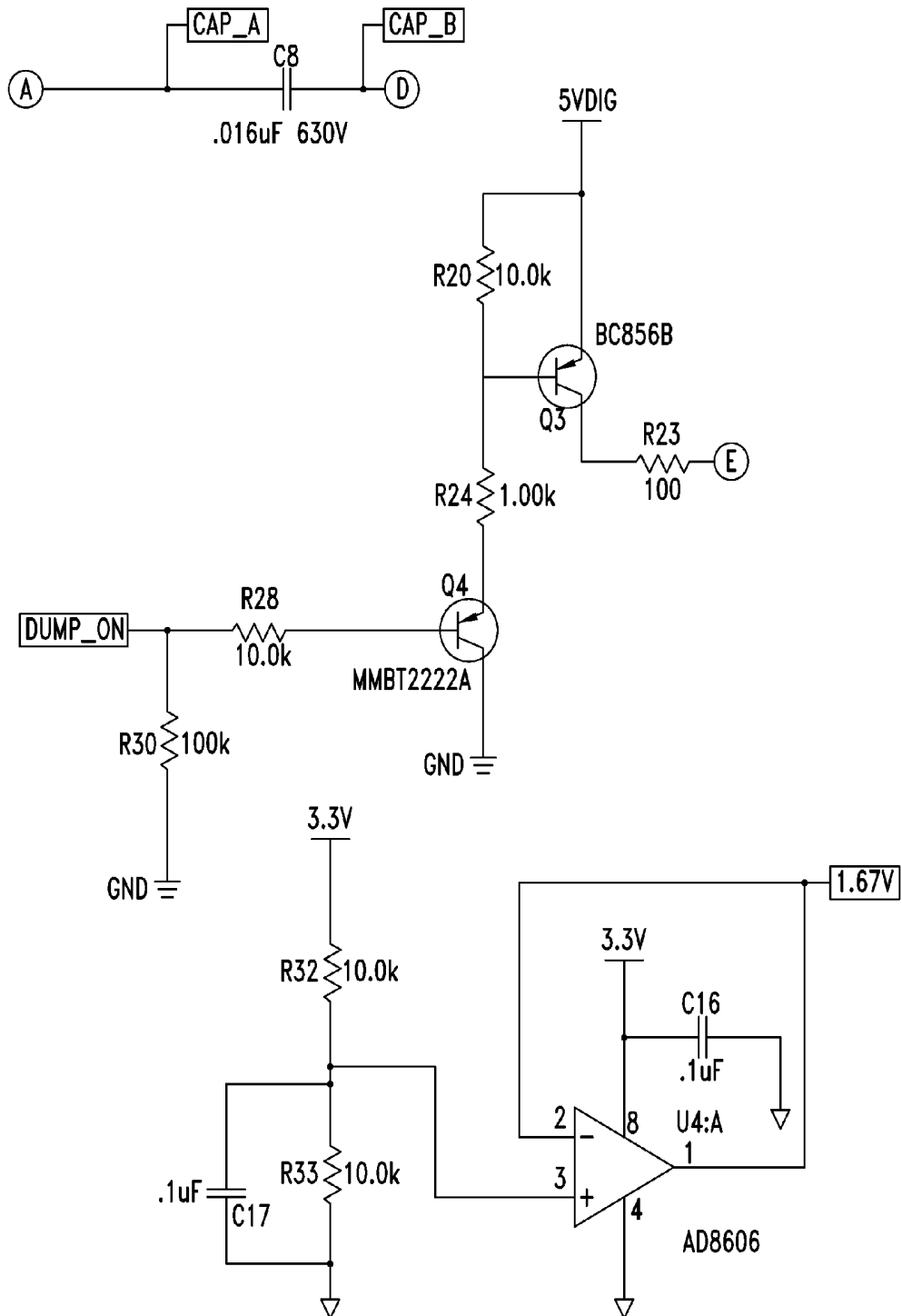

FIG. 19E

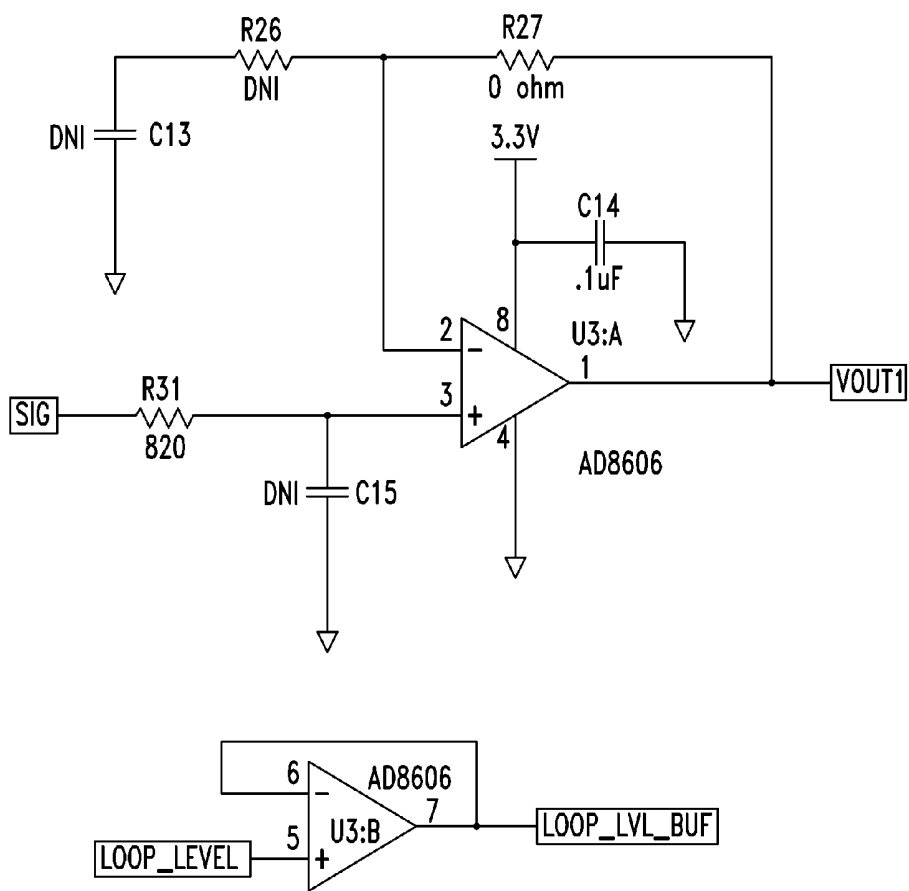

FIG. 19F

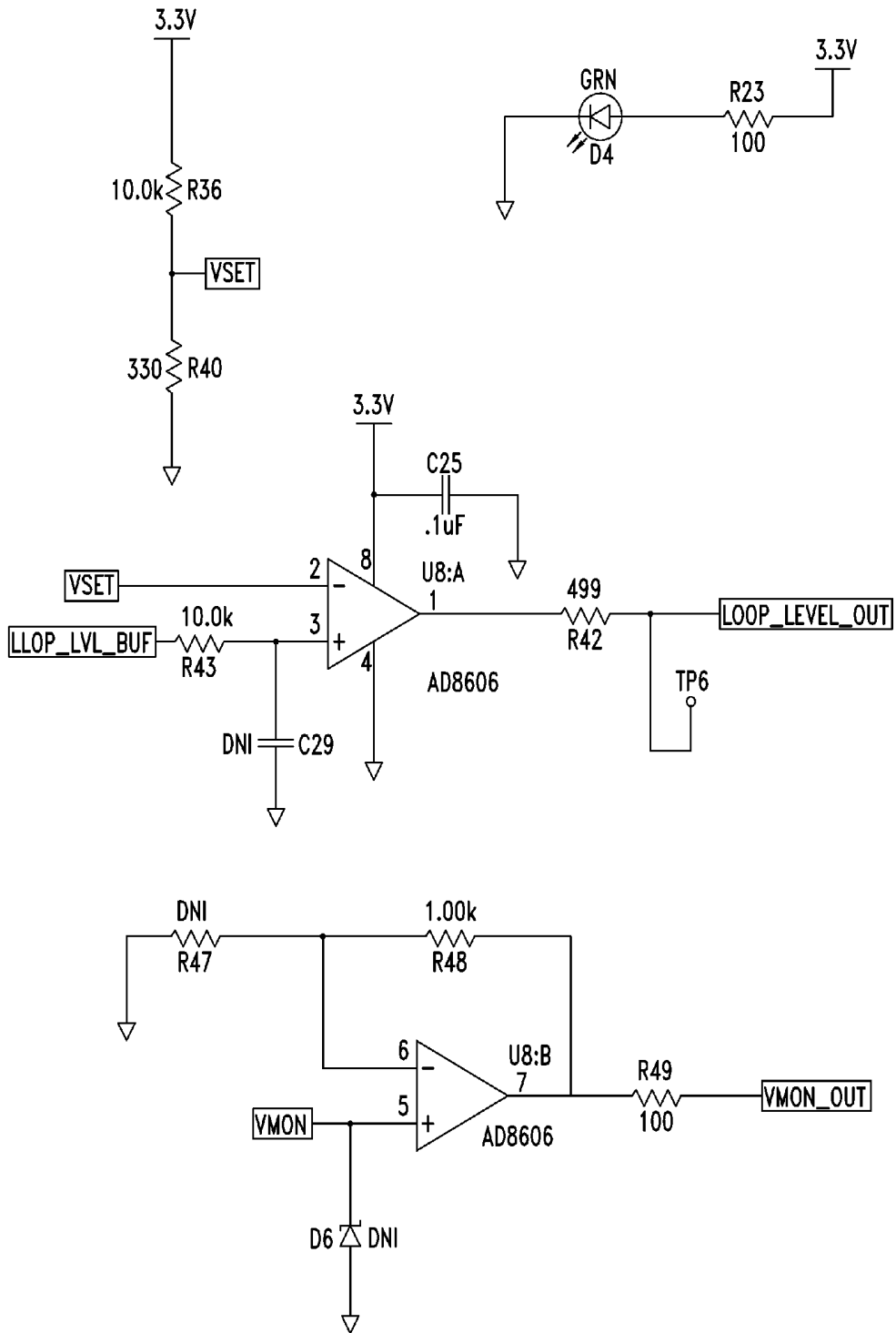

FIG. 19G



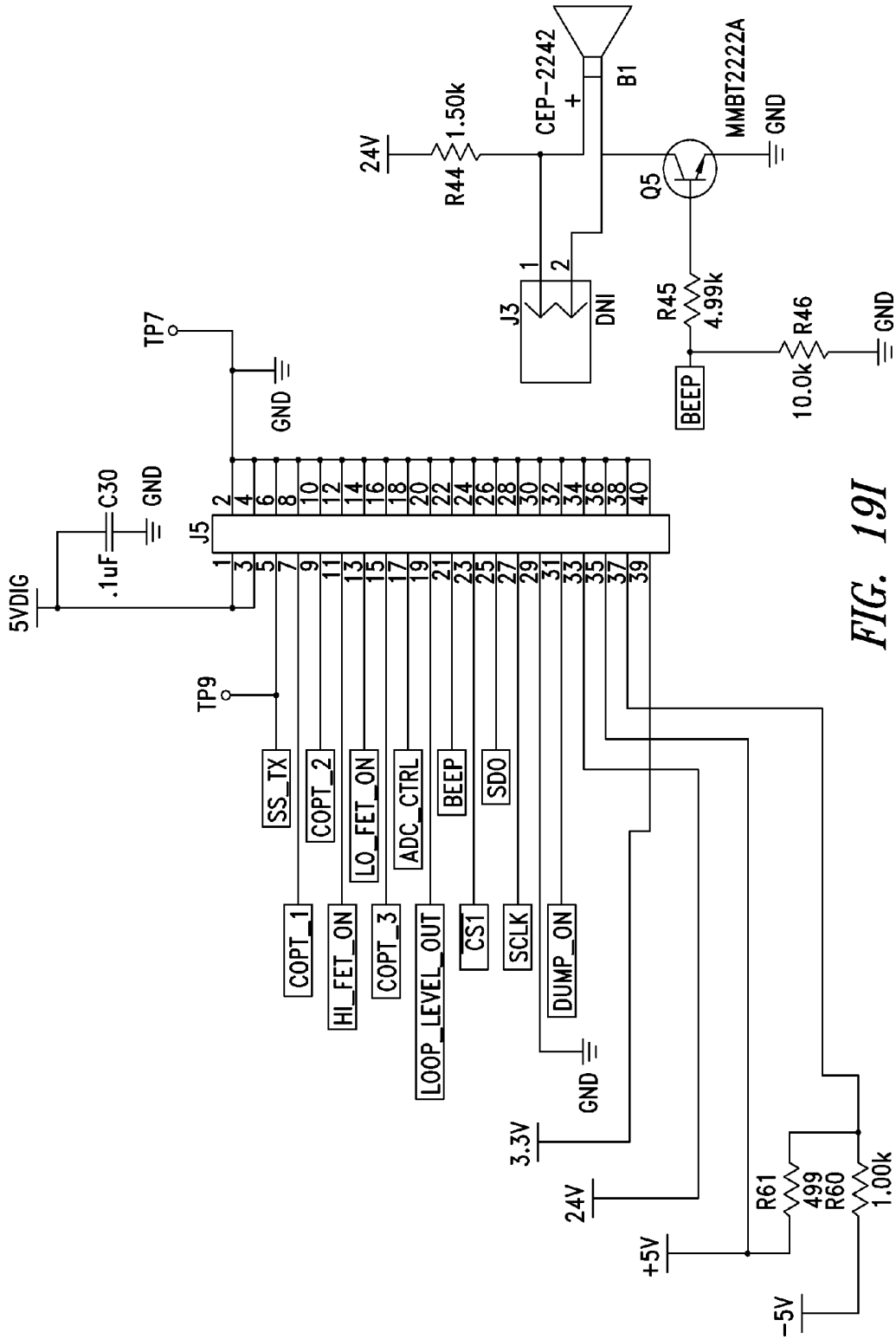

FIG. 19I

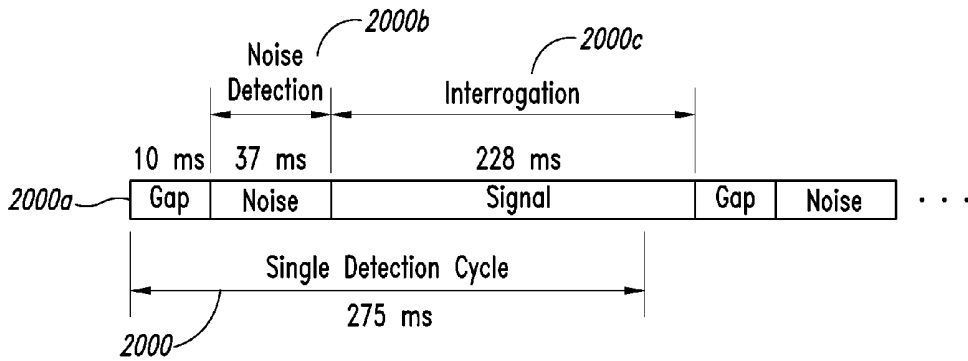

FIG. 20

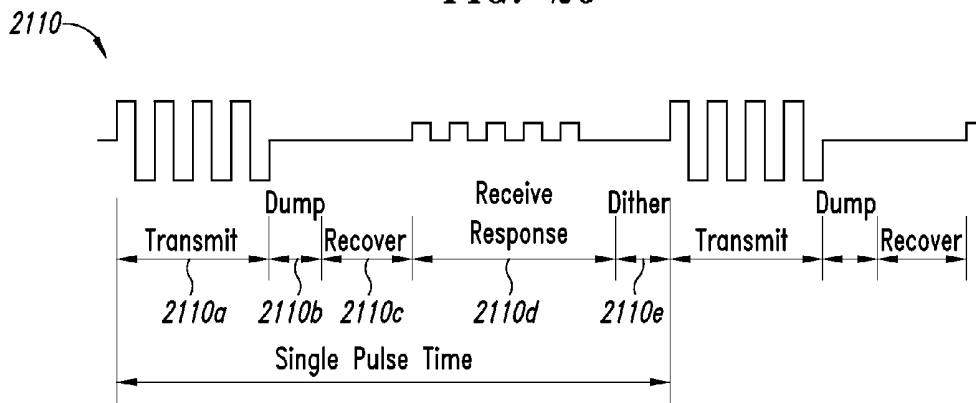

FIG. 21A

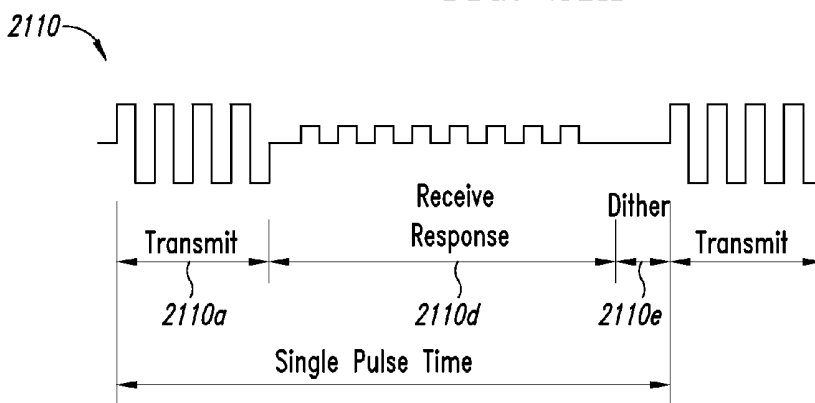

FIG. 21B

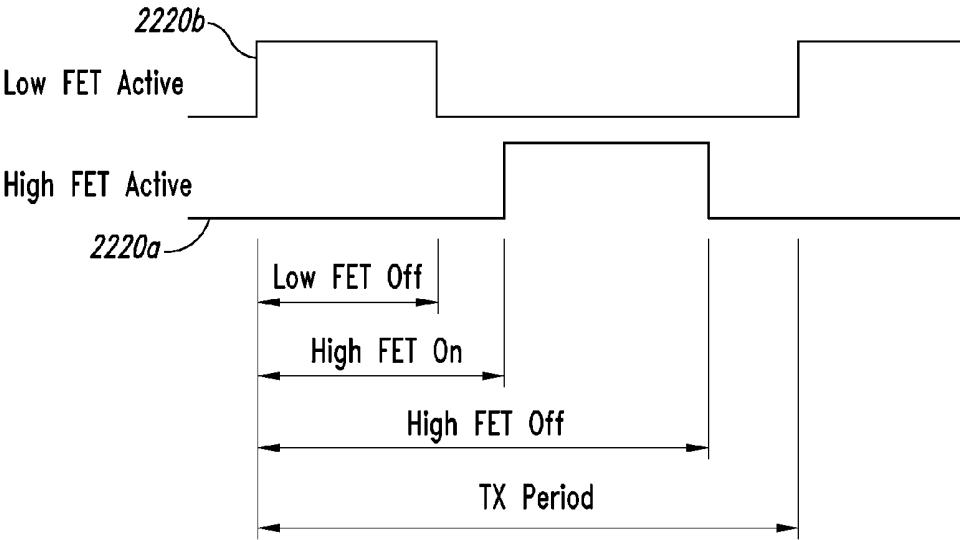
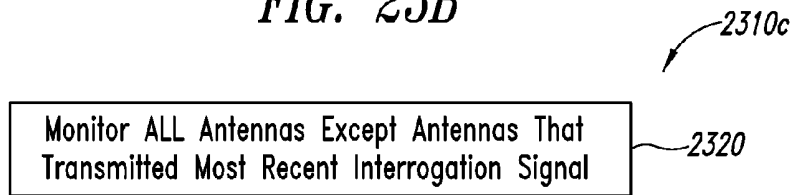
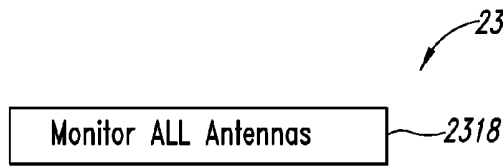
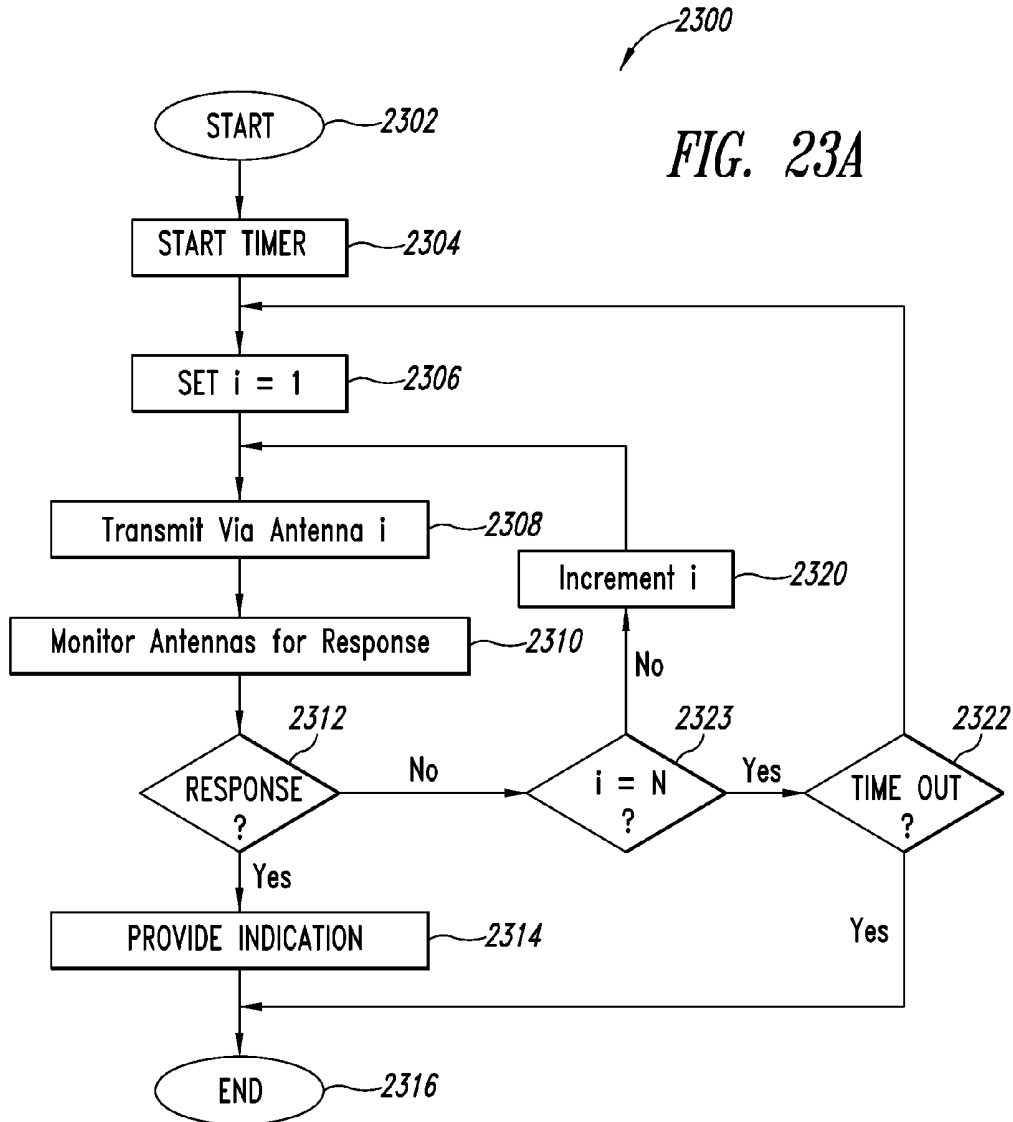

FIG. 22



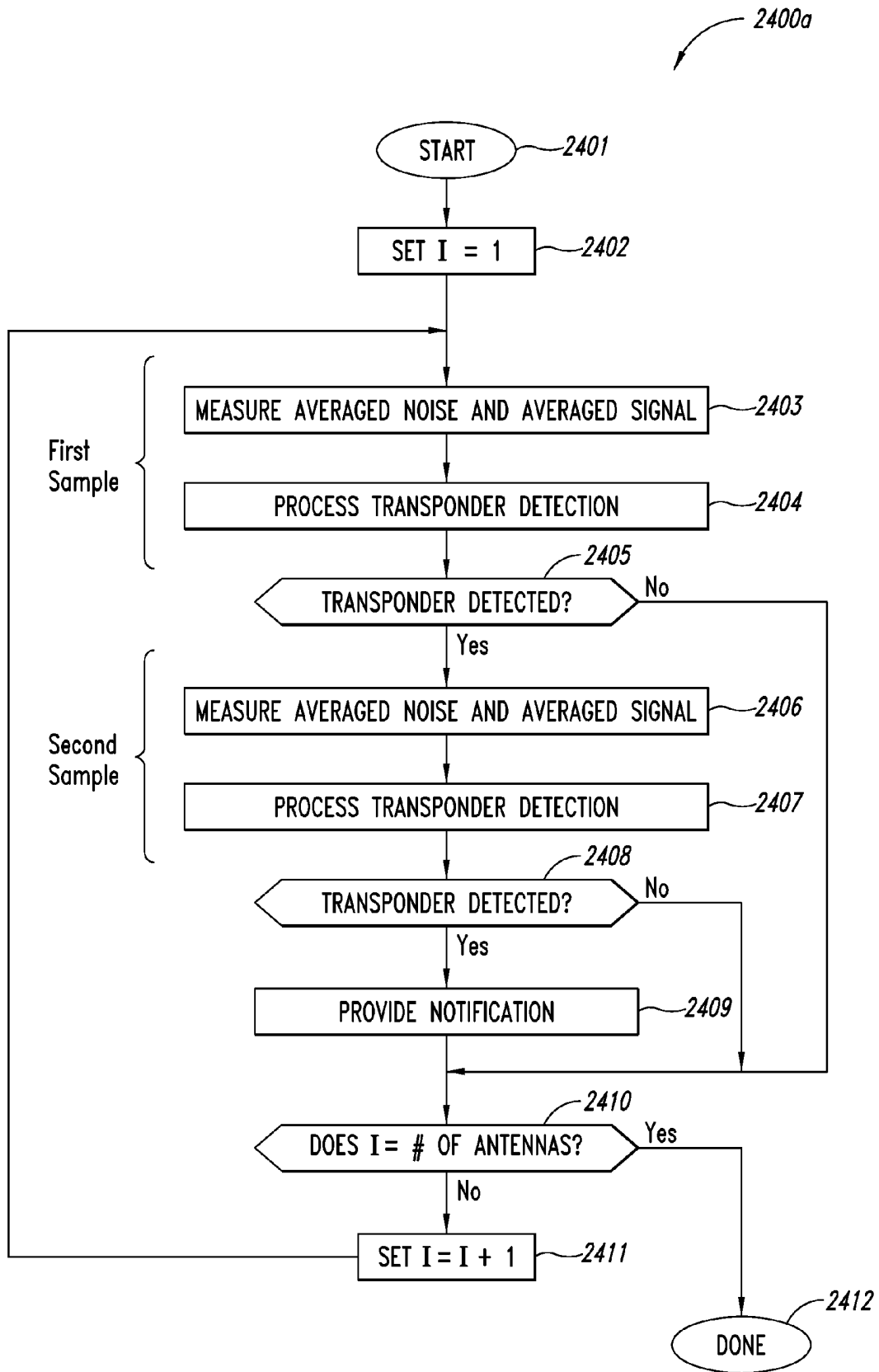

FIG. 24A

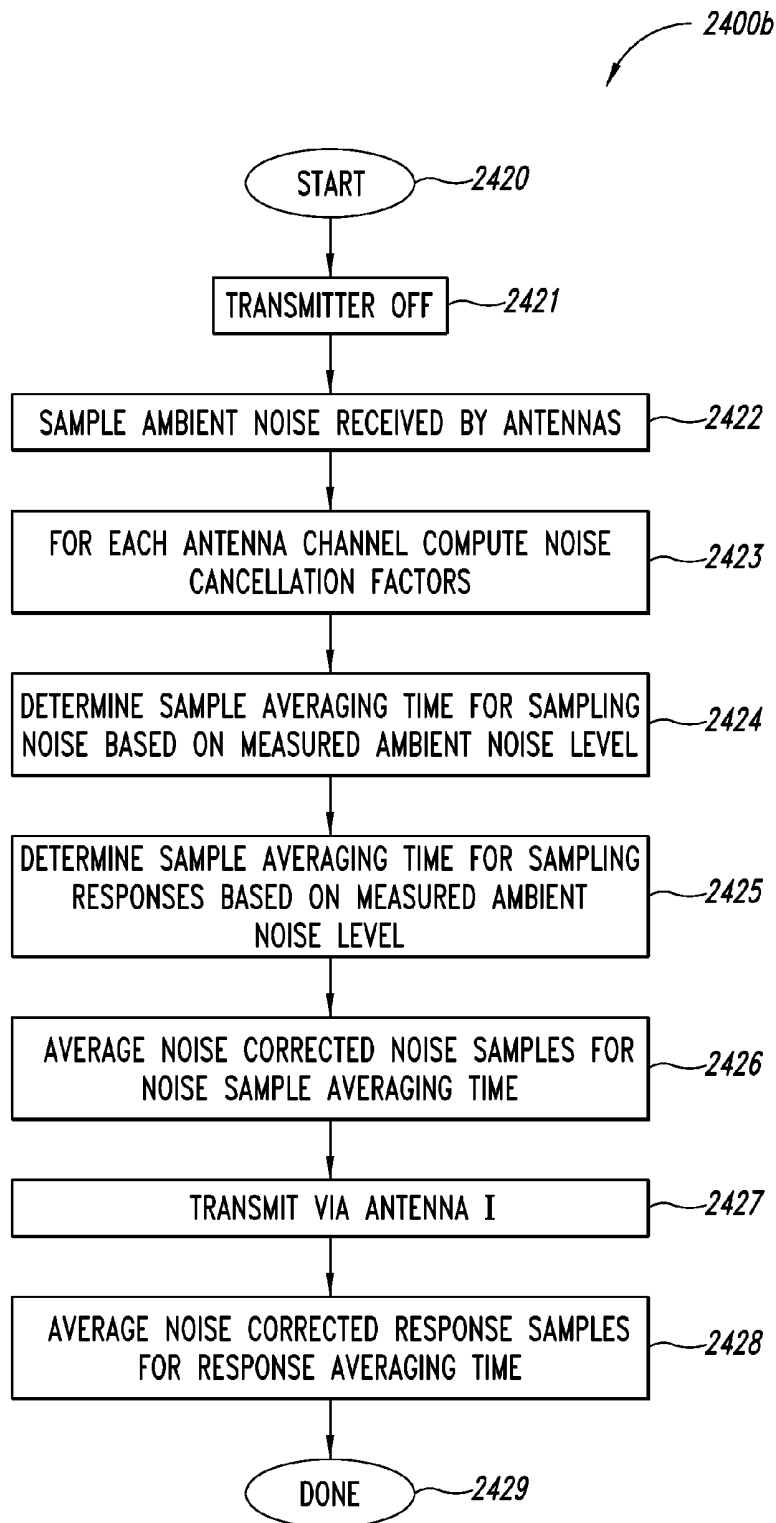

FIG. 24B

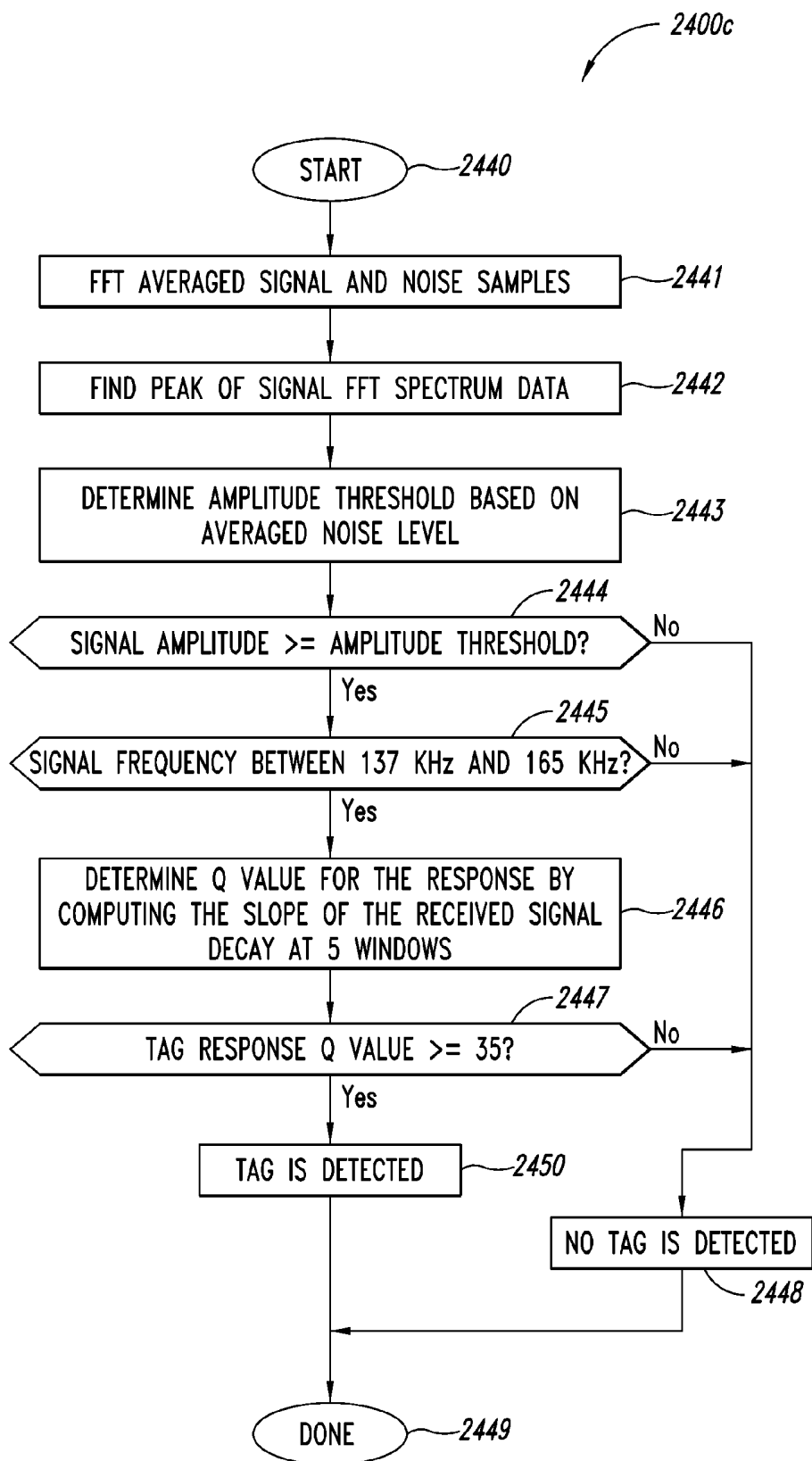

FIG. 24C



FIG. 25A

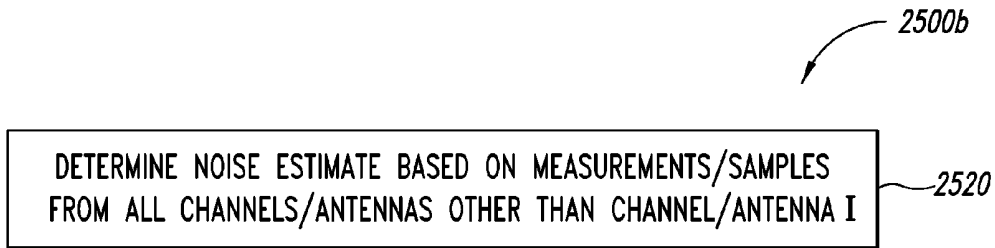

FIG. 25B

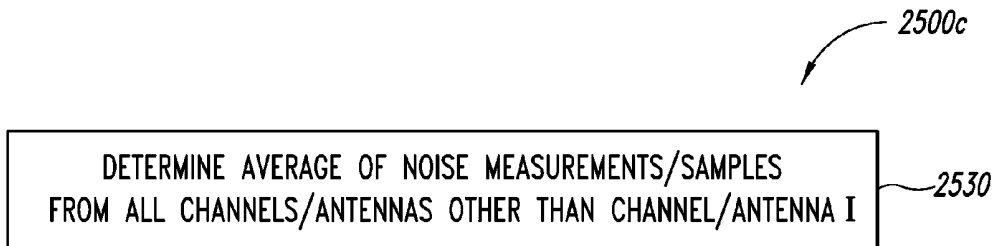

FIG. 25C

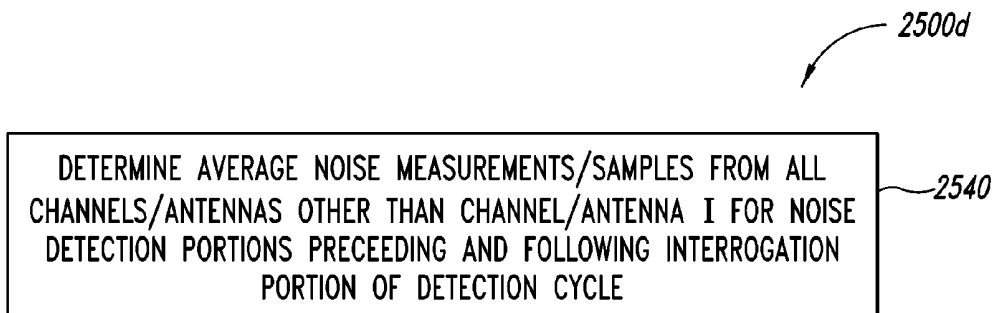

FIG. 25D

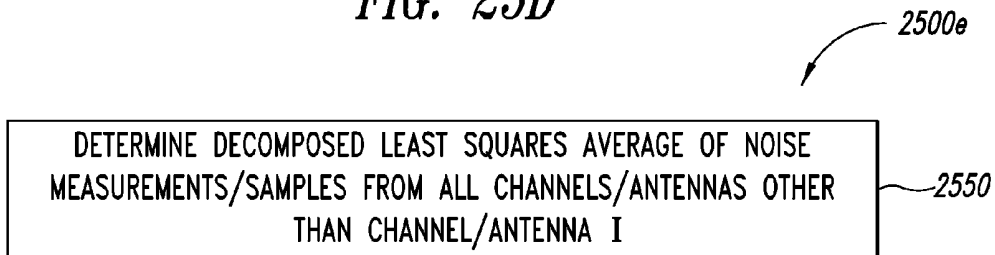
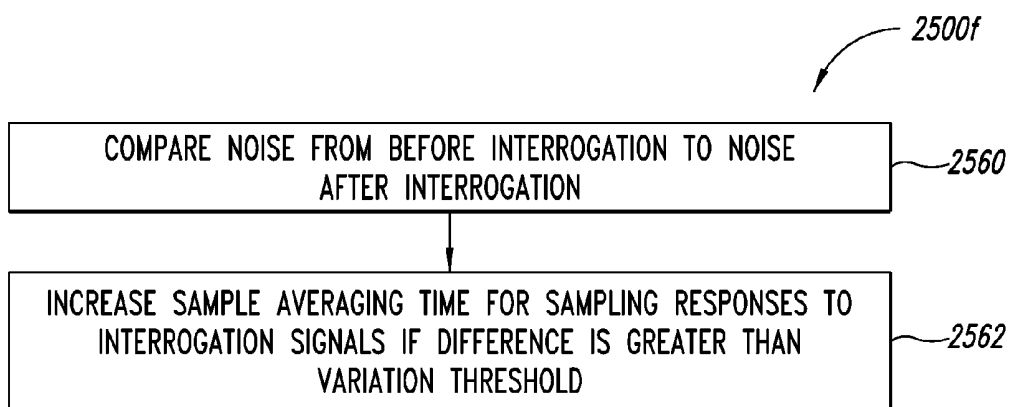

FIG. 25E



*FIG. 25F*

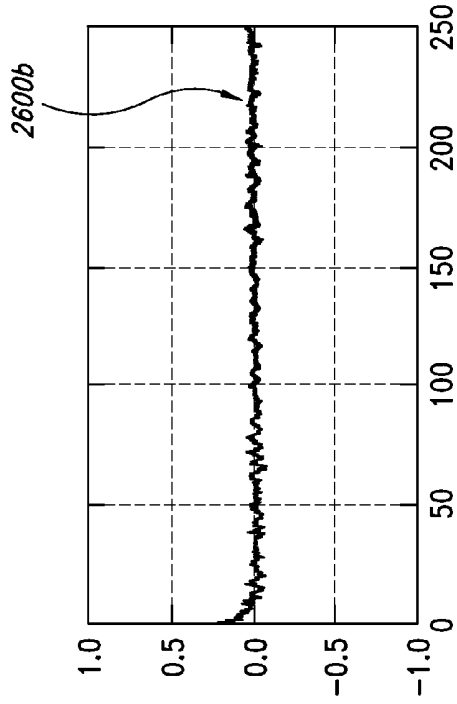

FIG. 26B

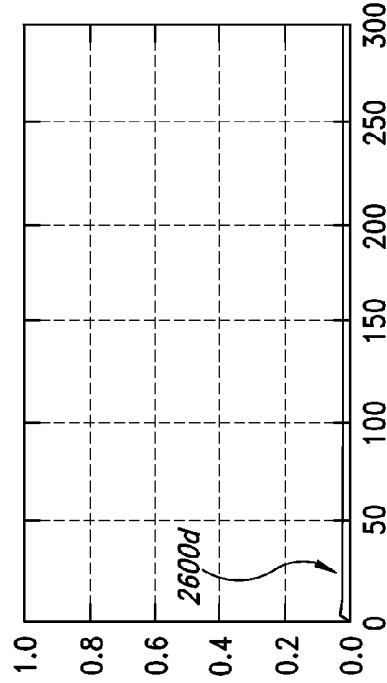

FIG. 26D

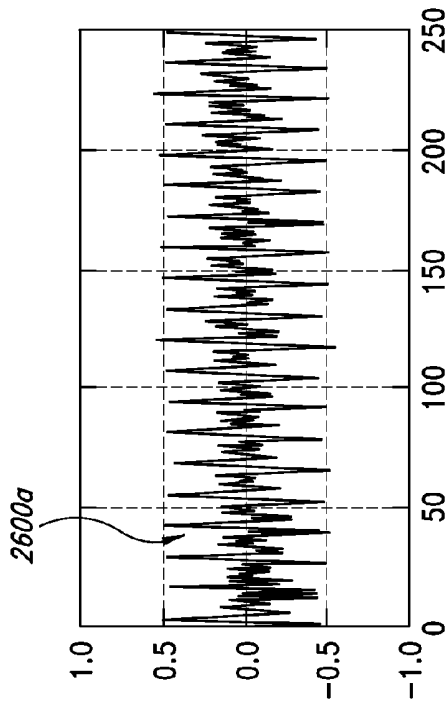

FIG. 26A

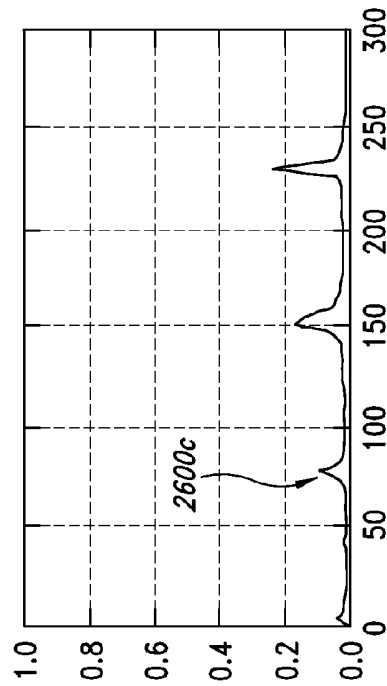

FIG. 26C

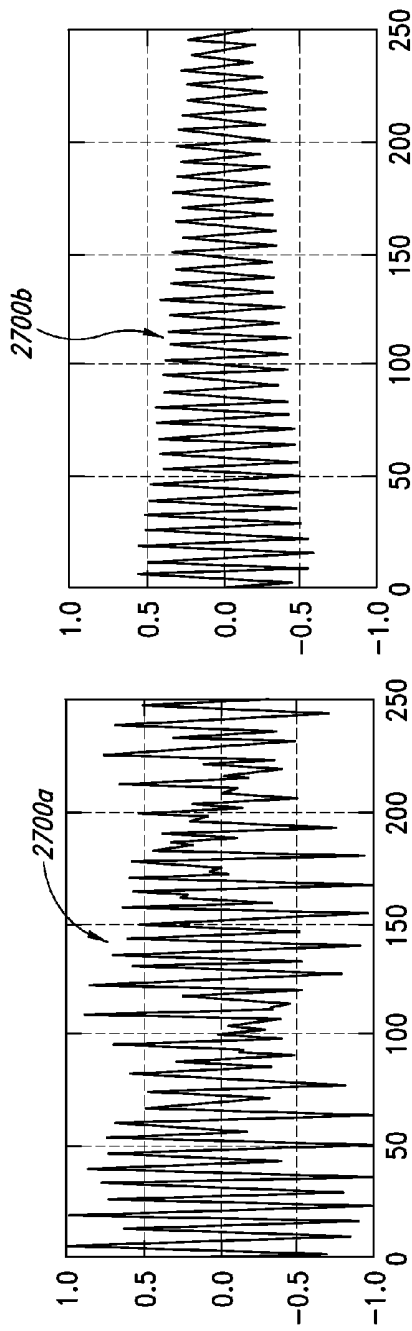

FIG. 27A

FIG. 27B

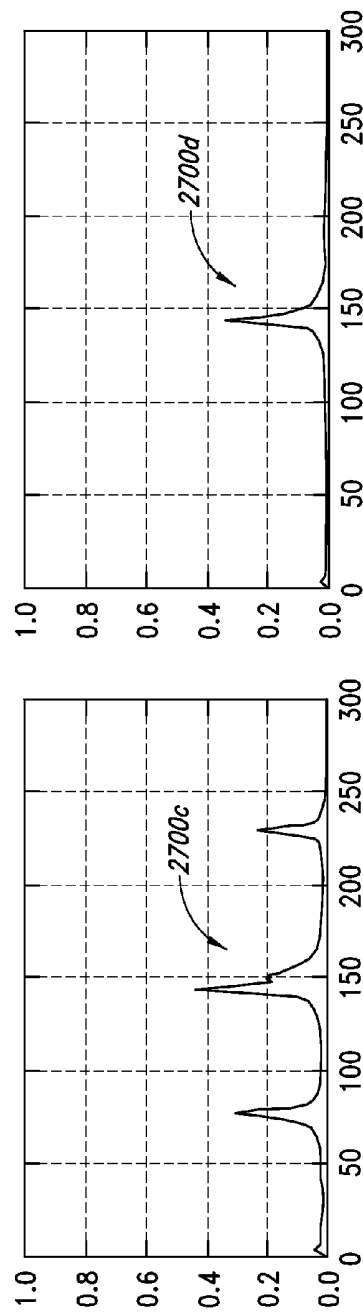

FIG. 27C

FIG. 27D

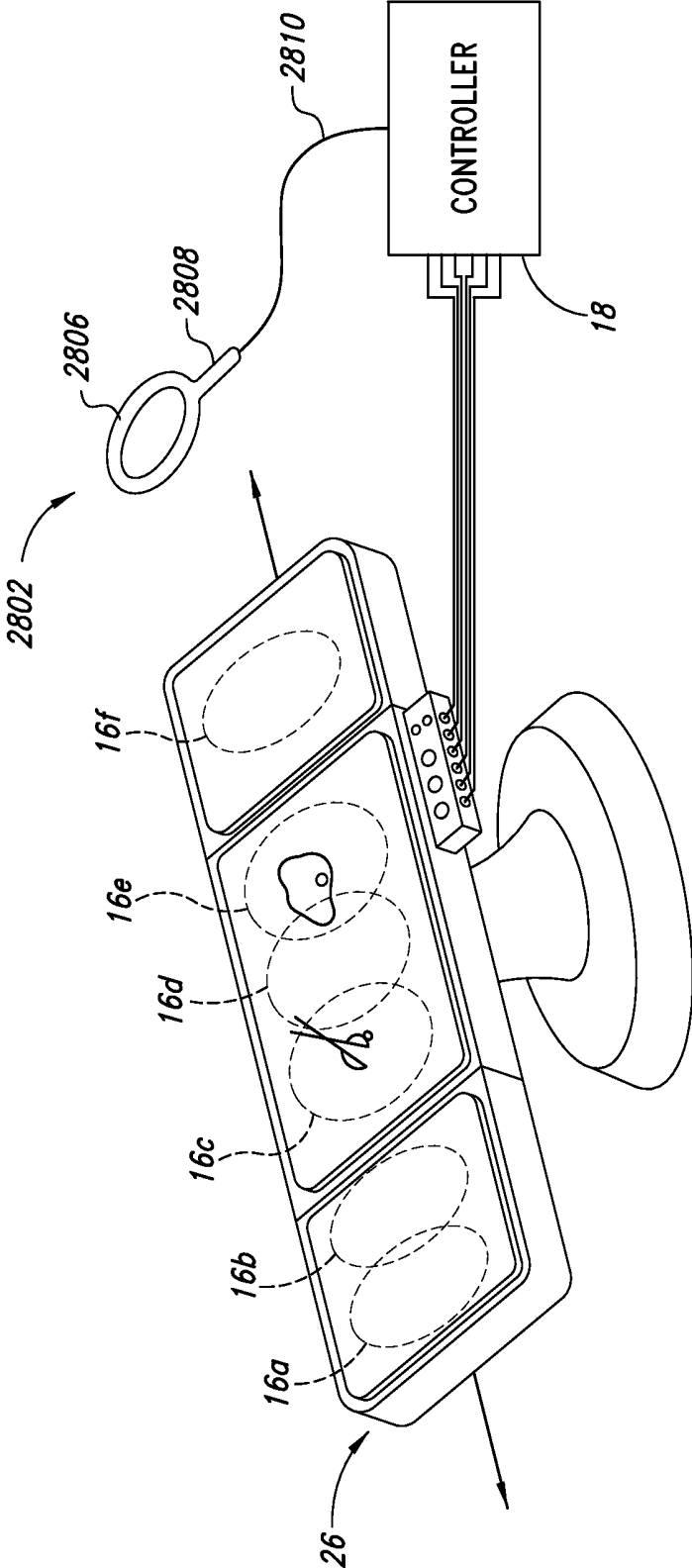

FIG. 28

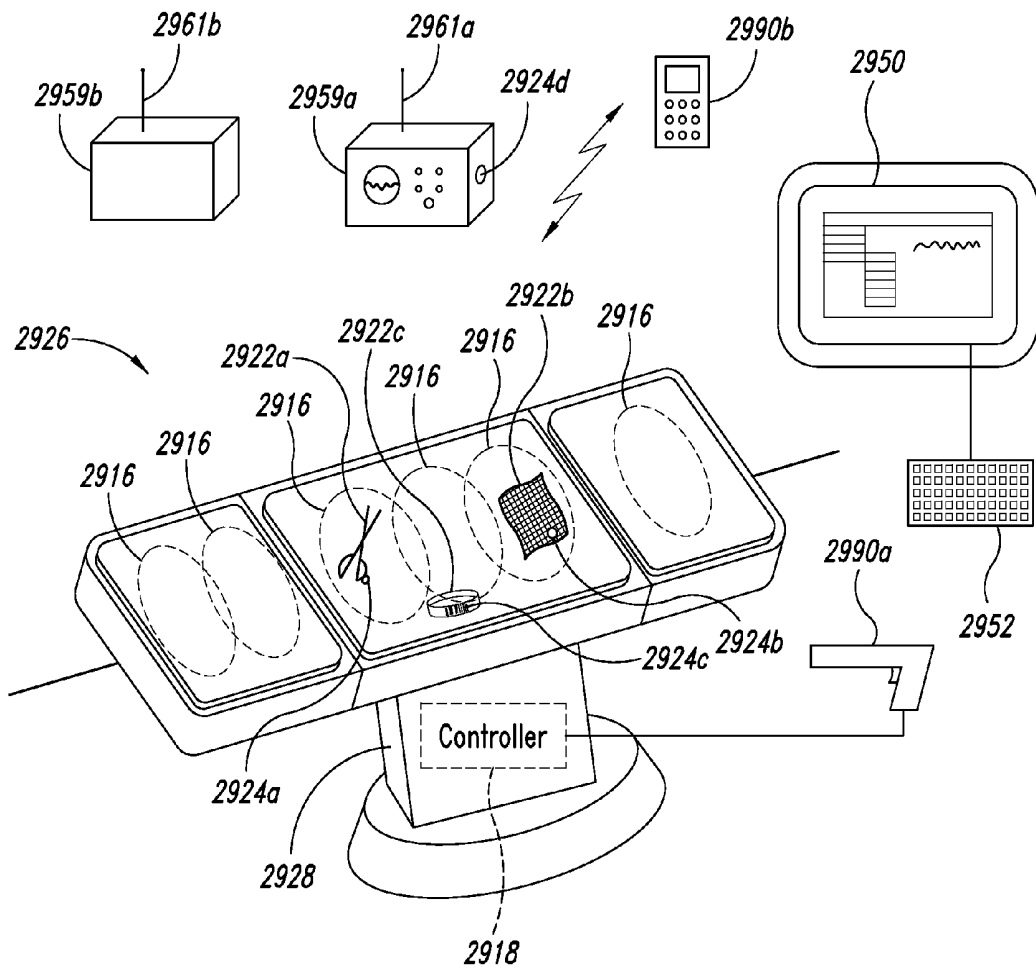

FIG. 29

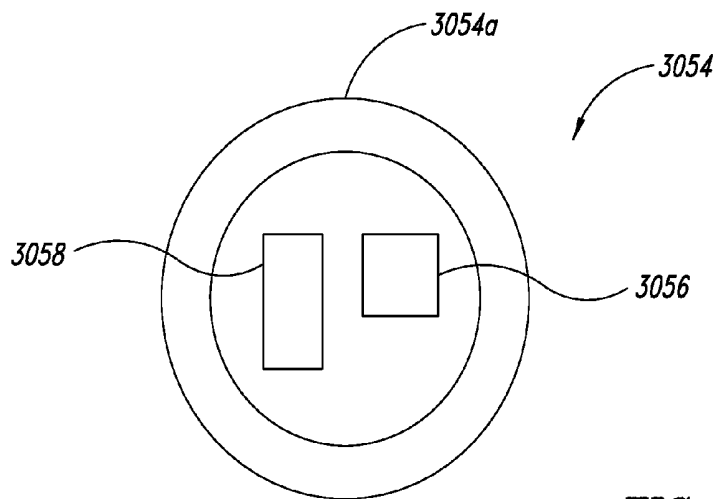
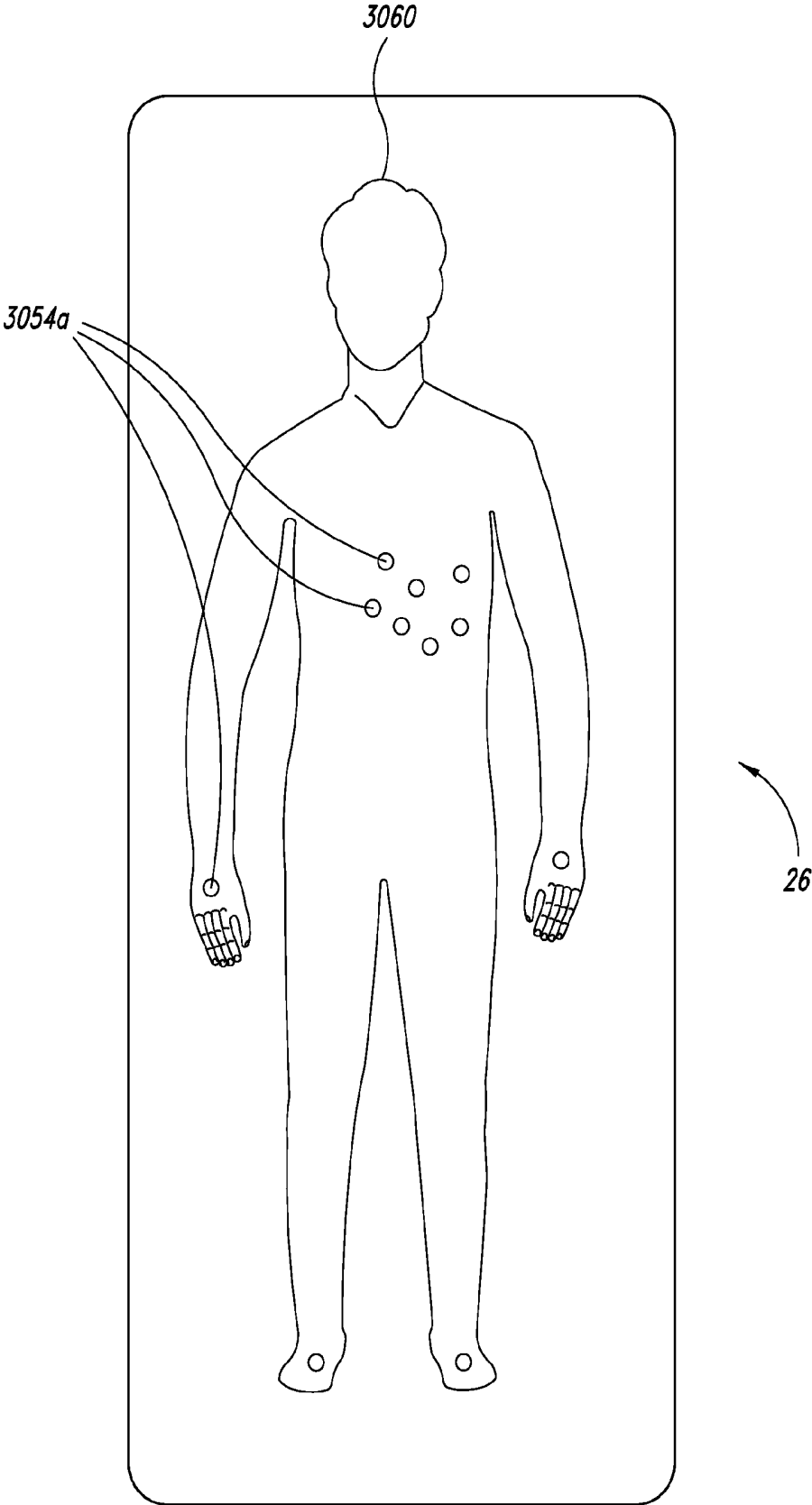

FIG. 30A



*FIG. 30B*

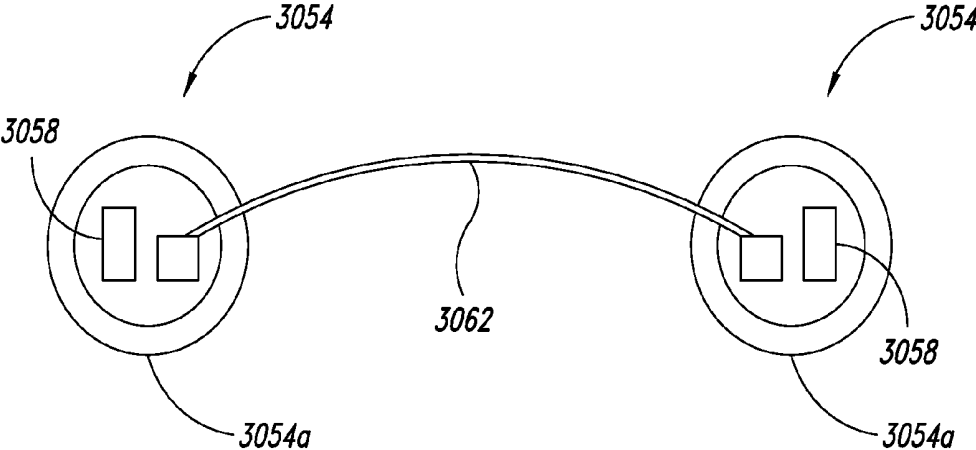

FIG. 30C

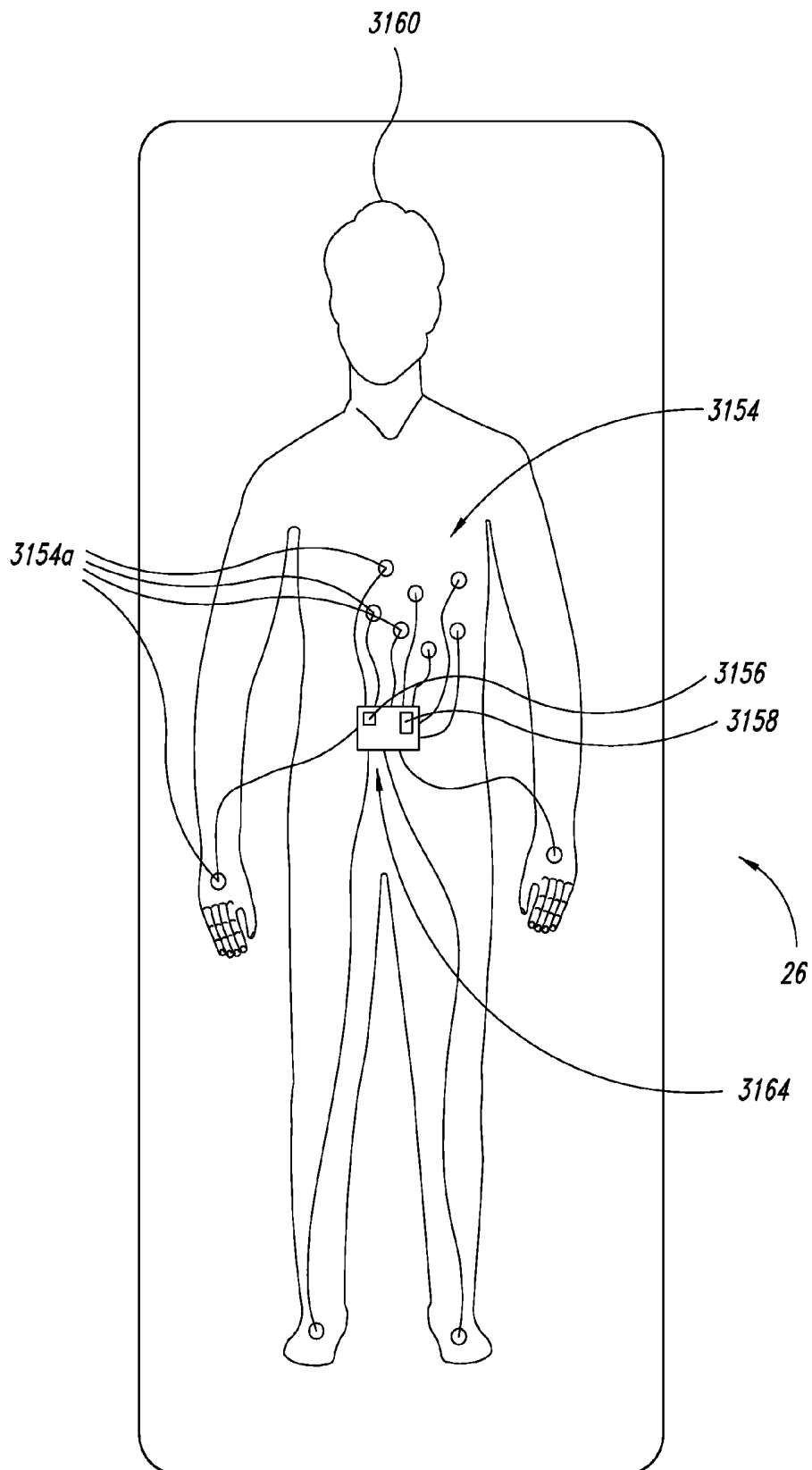

FIG. 31

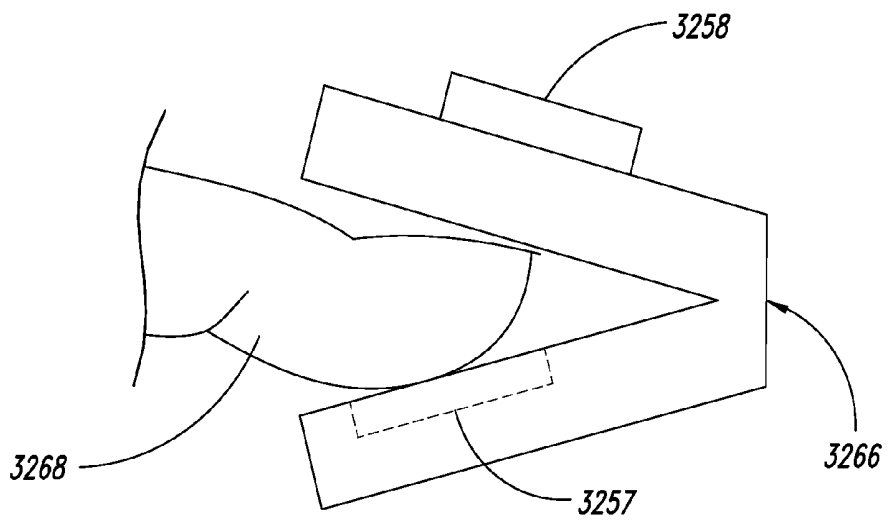

FIG. 32

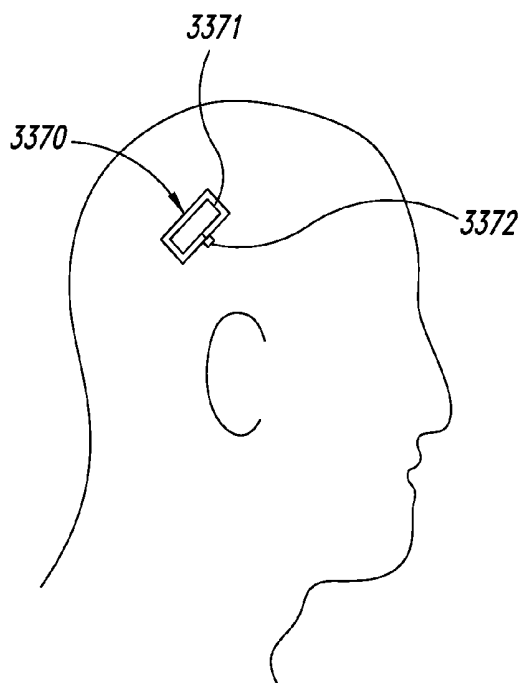
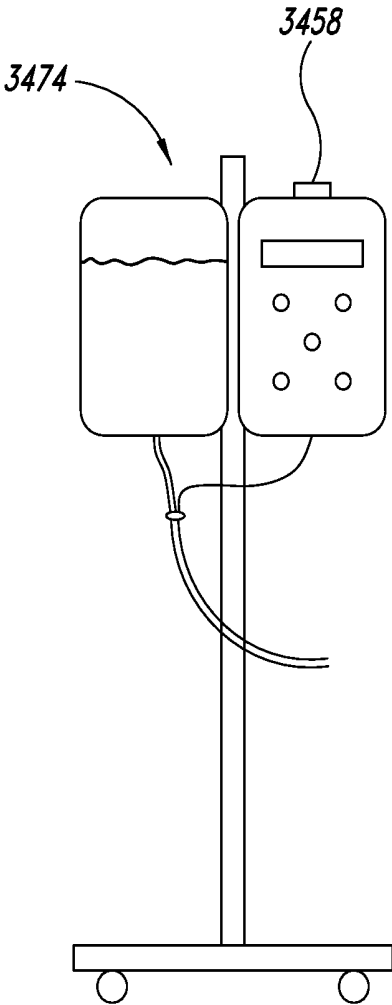

FIG. 33



*FIG. 34*

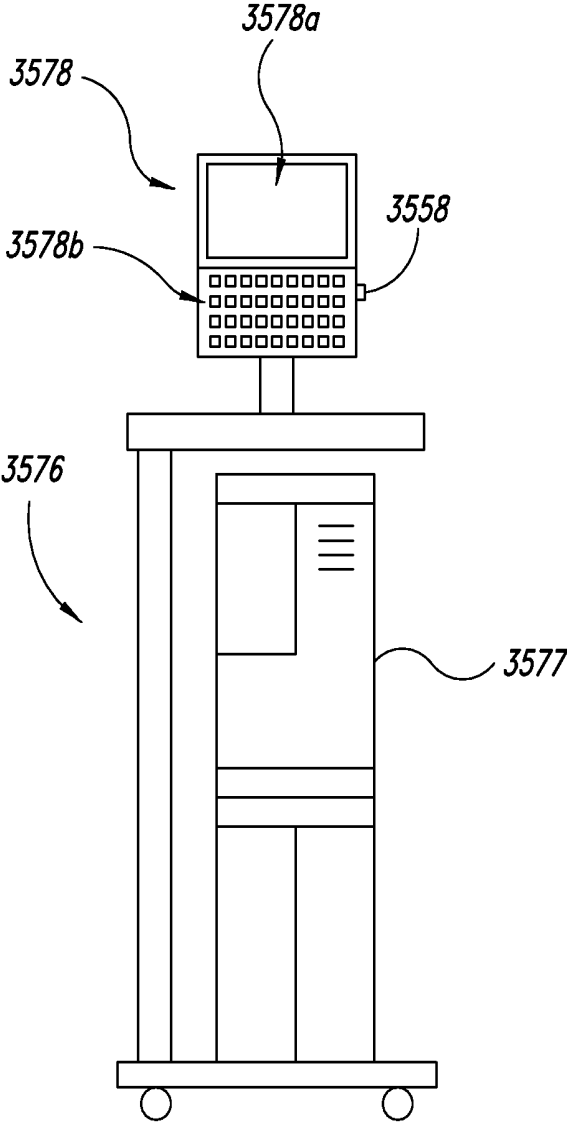

FIG. 35

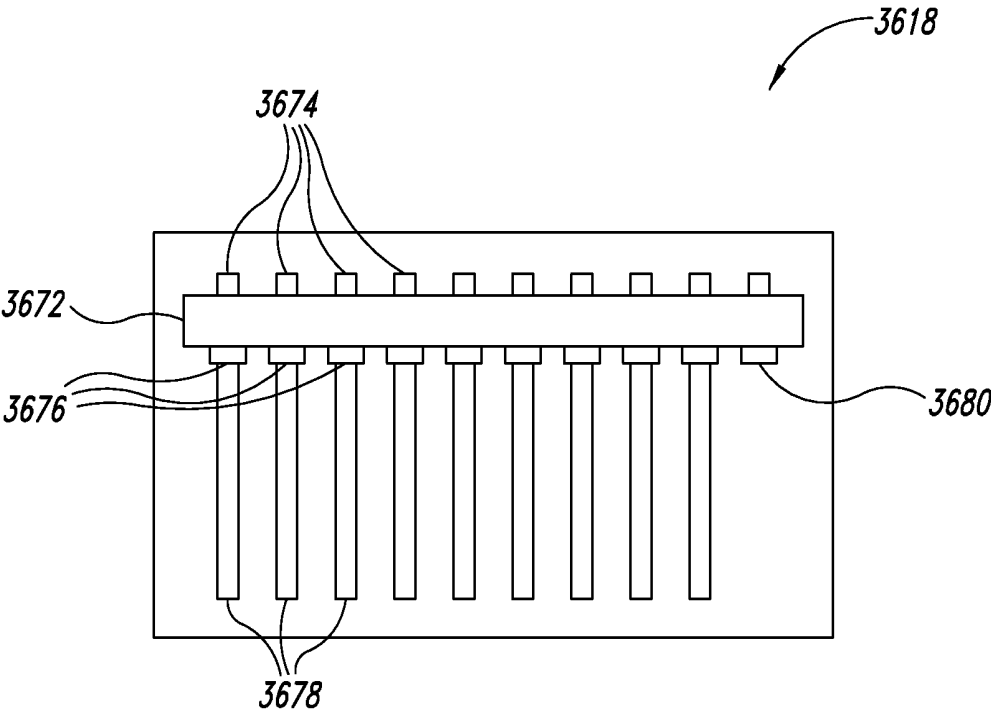

FIG. 36

**METHOD AND APPARATUS TO DETECT  
TRANSPONDER TAGGED OBJECTS AND TO  
COMMUNICATE WITH MEDICAL  
TELEMETRY DEVICES, FOR EXAMPLE  
DURING MEDICAL PROCEDURES**

**CROSS REFERENCE TO RELATED  
APPLICATIONS**

[0001] This application is a divisional patent application of U.S. patent application Ser. No. 12/606,963, now U.S. Pat. No. 9,792,408, and claims benefit under 35 U.S.C. 119(e) to U.S. provisional patent application Ser. No. 61/222,847 filed Jul. 2, 2009; and U.S. provisional patent application Ser. No. 61/242,699 filed Sep. 15, 2009, both of which are incorporated herein by reference in their entireties.

**BACKGROUND**

**Technical Field**

[0002] The present disclosure generally relates to a wireless medical procedure environment, and more particularly detection of transponder tagged objects and communications with various pieces of medical equipment in an environment in which medical procedures are performed.

**Description of the Related Art**

[0003] It is often useful or important to be able to determine the presence or absence of an object.

[0004] For example, it is important to determine whether objects associated with a medical procedure, for instance surgery or child birth delivery, are present in a patient's body before completion of the medical procedure. Such objects may take a variety of forms used in medical procedures. For example, the objects may take the form of instruments, for instance scalpels, scissors, forceps, hemostats, and/or clamps. Also for example, the objects may take the form of related accessories and/or disposable objects, for instance surgical sponges, gauzes, and/or absorbent pads. When used in surgery, failure to locate an object before closing the patient may require additional surgery, and in some instances may have serious adverse medical consequences. In other medical procedures, such as vaginal child birth deliveries, failure to remove objects, for instance gauze or absorbent pads can lead to infections.

[0005] Some hospitals have instituted procedures which include checklists or requiring multiple counts to be performed to track the use and return of objects during surgery. Such a manual approach is inefficient, requiring the time of highly trained personnel, and is prone to error.

[0006] Another approach employs transponders and a wireless interrogation and detection system. Such an approach employs wireless transponders which are attached to various objects used during surgery. The interrogation and detection system includes a transmitter that emits pulsed wideband wireless signals (e.g., radio or microwave frequency) and a detector for detecting wireless signals returned by the transponders in response to the emitted pulsed wideband signals. Such an automated system may advantageously increase accuracy while reducing the amount of time required of highly trained and highly compensated personnel. Examples of such an approach are

discussed in U.S. Pat. No. 6,026,818, issued Feb. 22, 2000, and U.S. Patent Publication No. US 2004/0250819, published Dec. 16, 2004.

[0007] Commercial implementation of such an automated system requires that the overall system be cost competitive and highly accurate. In particular, false negatives must be avoided to ensure that objects are not mistakenly left in the patient. Some facilities may wish to install a single interrogation and detection system in each surgery theater or room in which medical procedures are conducted, while other facilities may move an interrogation and detection system between multiple surgical theaters or other rooms. In either case, the overall system will require a large number of transponders, since at least one transponder is carried, attached or otherwise coupled to each object which may or will be introduced into a patient or subject during the medical procedure. Consequently, the transponders must be inexpensive. However, inexpensive transponders typically have a relatively large variation in the frequency of signals they emit, making it difficult to accurately detect the signals returned by the transponders. This may be particularly difficult in some environments which are noisy with respect to the particular resonant frequencies of the transponders. Rooms in hospitals in which medical procedures are performed tend to have increasingly larger amounts of electronic equipment, and hence are becoming notoriously noisy environments. Consequently, a new approach to detection of the presence and absence of transponder that facilitates the use of inexpensive transponders is highly desirable.

**BRIEF SUMMARY**

[0008] A system for use in a medical facility may be summarized as including a number of antennas and a controller communicatively coupled to the antennas and configured to selectively cause at least one of the antennas to emit an interrogation signal and to detect a response signal, if any, from a number of transponders physically coupled to a number of objects used in medical procedures, wherein the controller is further configured to provide wireless communications of at least one of data or instructions with at least one piece of dedicated medical diagnostic, therapeutic or monitoring equipment via the at least one of the antennas used to emit the interrogation signal or receive the response signal.

[0009] At least a plurality of the number of antennas may be carried by a patient support structure that carries a patient during a medical procedure. At least one of the number of antennas may be a handheld antenna that inductively cooperates with the plurality of antennas carried by the patient support structure. At least one of the number of antennas may be a handheld antenna, and one of the handheld antenna or the plurality of antennas carried by the patient support structure may transmit an interrogation signal and the other one of the handheld antenna or the plurality of antennas carried by the patient support surface may receive response signals, if any, to the interrogation signal. The number of antennas may include at least three loop antennas spaced along a longitudinal axis of the patient support structure, and the patient support surface may be one of an operating table, a bed, a mattress, or a sheet. At least a plurality of the number of antennas may be carried by a drape that at least partially surrounds a patient support structure that carries a patient during a medical procedure. At least a plurality of the number of antennas may be carried by a shade that extends

from a light fixture positioned relatively above a patient support structure that carries a patient during a medical procedure. The controller may be configured to receive data signals from the at least one piece of dedicated medical diagnostic, therapeutic or monitoring equipment via at least one of the number of antennas, the data signals representing physiological characteristics of the patient measured by the at least one piece of dedicated medical diagnostic, therapeutic or monitoring equipment. The controller may be configured to receive data signals from the at least one piece of dedicated medical diagnostic, therapeutic or monitoring equipment via at least one of the number of antennas, the data signals representing operational characteristics of the at least one piece of dedicated medical diagnostic, therapeutic or monitoring equipment. The controller may be configured to transmit control signals to the at least one piece of dedicated medical diagnostic, therapeutic or monitoring equipment via at least one of the number of antennas, the control signals representing operational instructions to control operation of the at least one piece of dedicated medical diagnostic, therapeutic or monitoring equipment. The controller may be communicatively coupled to a display and may be operable to display information related to at least one of the patient or the at least one piece of dedicated medical diagnostic, therapeutic or monitoring equipment. The controller may be communicatively coupled to a user input device and may be operable to receive user input entered via the user input device and to transmit control signals based on the received user input to the at least one piece of dedicated medical diagnostic, therapeutic or monitoring equipment via at least one of the number of antennas, the control signals representing operational instructions to control operation of the at least one piece of dedicated medical diagnostic, therapeutic or monitoring equipment. The controller may be configured to receive data signals from a first one of the at least one piece of dedicated medical diagnostic, therapeutic or monitoring equipment and to transmit the data signals to a second one of the at least one piece of dedicated medical diagnostic, therapeutic or monitoring equipment. A first one of the at least one piece of dedicated medical diagnostic, therapeutic or monitoring equipment may be a transducer coupled to the patient and a second one of the at least one piece of dedicated medical diagnostic, therapeutic or monitoring equipment may be a dedicated control system for the transducer. The first one of the at least one piece of dedicated medical diagnostic, therapeutic or monitoring equipment may be one of an electrocardiogram electrode, a pulse oximetry transducer and the second one of the at least one piece of dedicated medical diagnostic, therapeutic or monitoring equipment may be a dedicated electrocardiogram processing system or a pulse oximetry processing system. At least one of the antennas may be responsive to a force exerted thereon and the controller may be configured to receive a signal indicative of the force exerted on the antenna and to produce a notification if the force exceeds at least one of an amplitude threshold or a time duration.

**[0010]** A method of operating a system in a medical facility, the system including a plurality of antennas and a controller communicatively coupled to the antennas may be summarized as including from time-to-time, transmitting a number of wideband interrogation signals from at least one of the antennas; determining whether a response to the interrogation signals was received via at least one of the antennas from a transponder that marks an object used in a

medical procedure; from time-to-time, providing communications with at least one piece of dedicated medical diagnostic, therapeutic or monitoring equipment via the at least one of the antennas used to emit the interrogation signal or receive the response signal.

**[0011]** Transmitting a number of wideband interrogation signals from at least one of the antennas may include transmitting the wideband interrogation signals from a number of antennas carried by a patient support structure that carries a patient during a medical procedure. Transmitting a number of wideband interrogation signals from at least one of the antennas may include transmitting the wideband interrogation signals from a handheld antenna that inductively cooperates with the plurality of antennas carried by the patient support structure. At least one of the number of antennas may be a handheld antenna, and transmitting the wideband interrogation signals may include transmitting the wideband interrogation signal by one of the handheld antenna or the plurality of antennas carried by the patient support structure, and further may include receiving any response signals to the wideband interrogation signals by the other one of the handheld antenna or the plurality of antennas carried by the patient support structure. Transmitting a number of wideband interrogation signals from at least one of the antennas may include transmitting the wideband interrogation signals from at least three loop antennas spaced along a longitudinal axis of one of an operating table, a bed, a mattress or a sheet. Transmitting a number of wideband interrogation signals from at least one of the antennas may include transmitting the wideband interrogation signals from a plurality of antennas carried by a drape that at least partially surrounds a patient support surface that carries a patient during a medical procedure. Transmitting a number of wideband interrogation signals from at least one of the antennas may include transmitting the wideband interrogation signals from a plurality of antennas carried by a shade that extends from a light fixture positioned relatively above a patient support surface that carries a patient during a medical procedure. Providing communications with at least one piece of dedicated medical diagnostic, therapeutic or monitoring equipment via at least one of the antennas may include receiving data signals from the at least one piece of dedicated medical diagnostic, therapeutic or monitoring equipment via at least one of the number of antennas, the data signals representing physiological characteristics of the patient measured by the at least one piece of dedicated medical diagnostic, therapeutic or monitoring equipment. Providing communications with at least one piece of dedicated medical diagnostic, therapeutic or monitoring equipment via at least one of the antennas may include receiving data signals from the at least one piece of dedicated medical diagnostic, therapeutic or monitoring equipment via at least one of the number of antennas, the data signals representing operational characteristics of the at least one piece of dedicated medical diagnostic, therapeutic or monitoring equipment. Providing communications with at least one piece of dedicated medical diagnostic, therapeutic or monitoring equipment via at least one of the antennas may include transmitting control signals to the at least one piece of dedicated medical diagnostic, therapeutic or monitoring equipment via at least one of the number of antennas, the control signals representing operational instructions to control operation of the at least one piece of dedicated medical diagnostic, therapeutic or monitoring equipment. The

method may further include transmitting information by the controller to a display to display information related to at least one of the patient or the at least one piece of dedicated medical diagnostic, therapeutic or monitoring equipment. The method may further include receiving by the controller user input entered by a user via a user input device; and transmitting control signals by the controller based on the received user input to the at least one piece of dedicated medical diagnostic, therapeutic or monitoring equipment via at least one of the number of antennas, the control signals representing operational instructions to control operation of the at least one piece of dedicated medical diagnostic, therapeutic or monitoring equipment. The method may further include receiving data signals by the controller via at least one of the antennas from a first one of the at least one piece of dedicated medical diagnostic, therapeutic or monitoring equipment; and transmitting the received data signals to a second one of the at least one piece of dedicated medical diagnostic, therapeutic or monitoring equipment. Receiving data signals by the controller via at least one of the antennas from a first one of the at least one piece of dedicated medical diagnostic, therapeutic or monitoring equipment may include receiving data signals from a transducer coupled to the patient and transmitting the received data signals to a second one of the at least one piece of dedicated medical diagnostic, therapeutic or monitoring equipment may include transmitting the data signals to a dedicated control system for the transducer. Receiving data signals by the controller via at least one of the antennas from a first one of the at least one piece of dedicated medical diagnostic, therapeutic or monitoring equipment may include receiving data signals from one of an electrocardiogram electrode, a pulse oximetry transducer and transmitting the received data signals to a second one of the at least one piece of dedicated medical diagnostic, therapeutic or monitoring equipment may include transmitting the data signals to one of a dedicated electrocardiogram processing system or a pulse oximetry processing system. At least one of the antennas may be responsive to a force exerted thereon and may further include receiving signals by the controller indicative of the force exerted on the antenna; and may produce a notification if the force exceeds at least one of an amplitude threshold or a time duration.

**[0012]** A physiological condition monitor may be summarized as including a transducer coupleable to a patient to sense a physiological condition of the patient; an antenna physically coupled to the transducer; and a transmitter communicatively coupled to the transducer and to the antenna and configured to transmit signals indicative of the sensed physiological condition of the patient via the antenna to a plurality of antennas remote from the device. The antennas may be positioned proximate a patient support surface.

**[0013]** The physiological condition monitor may further include an energy storage device electrically coupled to provide power to the transmitter. The physiological condition monitor may further include a circuit configured to transform electromagnetic energy into electrical power, and coupled to supply the electrical power to the transmitter. The physiological condition monitor may further include a circuit that encodes an identifier that uniquely identifies the physiological condition monitor from other physiological condition monitors. The physiological condition monitor may have a portion that bears an optical marking. The

optical marking may encode an identifier which may uniquely identify the physiological condition monitor.

**[0014]** A system for use in a medical facility may be summarized as including a number of antennas, at least some of the antennas responsive to a force asserted thereon; and a controller communicatively coupled to the antennas and configured to selectively cause at least one of the antennas to emit an interrogation signal and to detect a response signal, if any, from a number of transponders physically coupled to a number of objects used in medical procedures, wherein the controller is further configured to receive signals from at least some of the antennas indicative of the force asserted on the antenna.

**[0015]** The controller may be configured to produce a notification if the force exerted on at least one of the antennas exceeds at least one of an amplitude threshold or a time duration threshold. The controller may be configured to produce a notification if the force exerted on at least one of the antennas exceeds an amplitude threshold over a period of time that exceeds a time duration threshold. The controller may be configured to produce a notification indicative of a position or location on the patient support structure or patient where an excessive force is being exerted. The controller may be configured to transmit a notification via at least one of the antennas in response to the force asserted on at least one of the antennas exceeding a defined threshold.

**[0016]** A method of operating a system in a medical facility, the system including a plurality of antennas and a controller communicatively coupled to the antennas, at least some of the antennas responsive to a force asserted thereon, may be summarized as including from time-to-time, transmitting a wideband interrogation signals from at least one of the antennas; determining whether a response to the interrogation signal was received via at least one of the antennas from a transponder that marks an object used in medical procedures; from time-to-time, receiving signals from at least some of the antennas indicative of the force asserted on the antenna.

**[0017]** The method may further include producing a notification by the controller which may be configured to produce a notification if the force exerted on at least one of the antenna exceeds at least one of an amplitude threshold or a time duration threshold. The method may further include producing a notification by the controller if the force exerted on at least one of the antenna exceeds an amplitude threshold over a period of time that exceeds a time duration threshold. The method may further include producing a notification by the controller indicative of a position or location on the patient support structure or patient where an excessive force is being exerted. The method may include transmitting a notification via at least one of the antennas in response to the force asserted on at least one of the antennas exceeding a defined threshold.

#### BRIEF DESCRIPTION OF THE SEVERAL VIEWS OF THE DRAWINGS

**[0018]** In the drawings, identical reference numbers identify similar elements or acts. The sizes and relative positions of elements in the drawings are not necessarily drawn to scale. For example, the shapes of various elements and angles are not drawn to scale, and some of these elements are arbitrarily enlarged and positioned to improve drawing legibility. Further, the particular shapes of the elements as drawn, are not intended to convey any information regarding

the actual shape of the particular elements, and have been solely selected for ease of recognition in the drawings.

[0019] FIG. 1 is a schematic diagram showing an environment in which a medical procedure is performed, for example a surgical environment including a table, bed or other structure to carry or support at least a portion of a patient, that includes a plurality of antennas, and a controller communicatively coupled to the antennas an interrogation and detection system to detect an object tagged with a transponder in a patient, according to one illustrated embodiment.

[0020] FIG. 2 is a top plan view of the table, bed or other structure of FIG. 1 showing the plurality of antennas, according to one illustrated embodiment.

[0021] FIG. 3 is a top plan view of the table, bed or other structure of FIG. 1 showing approximate ranges of each of the antennas of FIG. 2.

[0022] FIG. 4 is a top plan view of a patient support structure showing a number of antennas on a patient support surface and a number of antennas on an opposed surface, according to another illustrated embodiment.

[0023] FIG. 5A is a side elevational view of the patient support structure of FIG. 4.

[0024] FIG. 5B is a cross-sectional view of the patient support structure of FIG. 4 taken along section line 6 of FIG. 4.

[0025] FIG. 6A is a top plan view of a support structure showing a number of antennas on a patient support surface and a number of antennas on an opposed surface, according to yet another illustrated embodiment.

[0026] FIG. 6B is a cross-sectional view of the patient support structure of FIG. 6A taken along section line 7 of FIG. 6A.

[0027] FIG. 6C is a partial isometric view of the patient support structure of FIGS. 6A and 6B, enlarged to illustrate electrically conductive paths or traces of the antennas.

[0028] FIG. 7 is a cross-sectional view of a patient support structure having recesses in which the antennas are received, according to another illustrated embodiment.

[0029] FIG. 8A is a top plan view of a patient support structure in the form of a bed or an operating table showing a number of antennas arranged in a non-overlapping relationship, according to another illustrated embodiment.

[0030] FIG. 8B is a top plan view of a patient support structure in the form of a mattress or pad showing a number of antennas arranged in a non-overlapping relationship, according to another illustrated embodiment.

[0031] FIG. 8C is a top plan view of a patient support structure in the form of a sheet showing a number of antennas arranged in a non-overlapping relationship, according to another illustrated embodiment.

[0032] FIG. 9 is an enlarged top plan view of an antenna according to one illustrated embodiment, where the antenna is formed from multiple coils of a conductive material that is radiolucent.

[0033] FIG. 10A is an enlarged top plan view of an antenna according to one illustrated embodiment, wherein the antenna is formed of a top coil of conductive material and a bottom coil of conductive material.

[0034] FIG. 10B is an enlarged top plan view of the top coil of the antenna FIG. 10A.

[0035] FIG. 10C is an enlarged top plan view of the bottom coil of the antenna FIG. 10A.

[0036] FIG. 10D is a cross-sectional view of a portion of a patient support structure carrying the top and bottom coils of the antenna of FIG. 10A according to one illustrated embodiment.

[0037] FIG. 10E is a cross-sectional view of a patient support structure with a plurality of antennas according to another illustrated embodiment.

[0038] FIG. 10F is a top plan view of a patient support structure comprising a plurality of antennas according to still another illustrated embodiment.

[0039] FIG. 11 is a cross-sectional view of a portion of a patient support structure with an antenna carried in opposed surfaces thereof, according to yet still another illustrated embodiment.

[0040] FIG. 12 is a cross-sectional view of a portion of a patient support structure an antenna of FIG. 10A carried on opposed surfaces thereof, according to even another illustrated embodiment.

[0041] FIG. 13A is a schematic diagram showing a surgical table with a plurality of antennas and a controller positioned in a pedestal of the surgical table, according to another illustrated embodiment.

[0042] FIG. 13B is a schematic diagram showing a bed such as a patient bed used in an environment where medical procedures are performed, the bed including a plurality of antennas and a controller positioned on a frame of the bed, according to another illustrated embodiment.

[0043] FIG. 14A is a side elevational view of an overhead light fixture for use in a medical procedure and a light shade with several antennas supported by the light fixture, according to one embodiment in which the light shade is shown in a retracted position or configuration of FIG. 10A.

[0044] FIG. 14B is a side elevational view of the light fixture and a light shade in which the light shade is shown in an extended position or configuration.

[0045] FIG. 14C is a side elevational view of a light fixture for use in a medical procedure and a light shade with several antennas according to another illustrated embodiment.

[0046] FIG. 15A is an isometric view of a track and a curtain or drape containing several antennas, according to one illustrated embodiment.

[0047] FIG. 15B is a side elevational view of a sheet containing several antennas and configured to be hung from a support according to one embodiment.

[0048] FIG. 16 is a schematic diagram of a controller, according to one illustrated embodiment, including a motherboard and a plurality of plug-in boards, one for each of the antennas.

[0049] FIG. 17 is a schematic diagram of a portion of a control system of the interrogation and detection system, according to one illustrated embodiment.

[0050] FIG. 18 is a schematic diagram of a software configuration of the interrogation and detection system, according to one illustrated embodiment.

[0051] FIGS. 19A-19I are an electrical schematic diagram of the interrogation and detection system including a control circuit and antenna, according to one illustrated embodiment.

[0052] FIG. 20 is a timing diagram illustrating a method of frequency hopping, according to one illustrated embodiment.

[0053] FIG. 21A is a timing diagram illustrating pulsed timing, according to one illustrated embodiment.

[0054] FIG. 21B is a timing diagram illustrating pulsed timing, according to another illustrated embodiment.

[0055] FIG. 22 is a timing diagram showing activation of a pair of transistors of the control circuit in a push-pull configuration to drive the antenna, according to one illustrated embodiment.

[0056] FIG. 23A is a flow diagram of a method of operating an interrogation and detection system, according to one illustrated embodiment.

[0057] FIG. 23B is a flow diagram of a method of monitoring all antennas for a response to an interrogation signal, according to one illustrated embodiment.

[0058] FIG. 23C is a flow diagram of a method of monitoring all antennas except a transmitting antenna for a response to an interrogation signal, according to one illustrated embodiment.

[0059] FIG. 24A is a high level flow diagram of a method of operating an interrogation and detection system to detect transponders, according to one illustrated embodiment.

[0060] FIG. 24B is a low level flow diagram of a method of operating an interrogation and detection system to sample noise and responses and to adjust sampling times and perform noise correction, according to one illustrated embodiment, the method useful with the method of FIG. 24A.

[0061] FIG. 24C is a flow diagram of a method of operating an interrogation and detection system to determine whether a transponder has been detected, according to one illustrated embodiment, the method useful with the method of FIG. 24A.

[0062] FIGS. 25A-25F are flow diagrams of methods of operating an interrogation and detection system by measuring and/or compensating for noise, according to various illustrated embodiments, the methods useful with the method of FIG. 24A.

[0063] FIG. 26A is a graph showing a measured or sampled response versus time without noise cancellation where a noise source is present but no transponder is present, according to one illustrated embodiment.

[0064] FIG. 26B is a graph showing a measured or sampled response versus time with noise cancellation where a noise source is present but no transponder is present, according to one illustrated embodiment.

[0065] FIG. 26C is a graph showing a measured or sampled response versus frequency without noise cancellation where a noise source is present but no transponder is present, according to one illustrated embodiment.

[0066] FIG. 26D is a graph showing a measured or sampled response versus frequency with noise cancellation where a noise source is present but no transponder is present, according to one illustrated embodiment.

[0067] FIG. 27A is a graph showing a measured or sampled response versus time without noise cancellation where a noise source and a transponder are present, according to one illustrated embodiment.

[0068] FIG. 27B is a graph showing a measured or sampled response versus time with noise cancellation where a noise source and a transponder are present, according to one illustrated embodiment.

[0069] FIG. 27C is a graph showing a measured or sampled response versus frequency without noise cancellation where a noise source and a transponder are present, according to one illustrated embodiment.

[0070] FIG. 27D is a graph showing a measured or sampled response versus frequency with noise cancellation where a noise source and a transponder are present, according to one illustrated embodiment.

[0071] FIG. 28 is an isometric view of a surgical environment including an operating table that carries a plurality of antennas, a hand held wand antenna, and a controller according to one illustrated embodiment.

[0072] FIG. 29 is an isometric view of a surgical environment including a patient support structure in the form of a surgical table that includes a plurality of antennas, and a controller communicatively coupled to the antennas and to a display screen and user input.

[0073] FIG. 30A is a top plan view of a wireless electrode, according to one illustrated embodiment.

[0074] FIG. 30B is top plan view of a plurality of wireless electrode attached to a patient on a patient support structure.

[0075] FIG. 30C is a top plan view of two wireless electrodes connected by one wire.

[0076] FIG. 31 is a top plan view of a plurality of leads attached to a patient, each lead extending to an intermediary relay which wirelessly communicates with at least one antenna of an interrogation and detection system.

[0077] FIG. 32 is a side elevational view of a wireless pulse oximeter attached to the finger of a patient,

[0078] FIG. 33 is a side elevational view of a wireless intra-cranial pressure monitor attached to a patient's head.

[0079] FIG. 34 is a side elevational view of an infusion pump with a radio attached thereto.

[0080] FIG. 35 is a side elevation view of an intra-aortal balloon pump with a radio attached thereto.

[0081] FIG. 36 is a schematic diagram of a controller, according to one illustrated embodiment, including a motherboard and a plurality of plug-in boards, one for each of the antennas, as well as additional plug-in boards to enable communication with medical telemetry devices.

#### DETAILED DESCRIPTION

[0082] In the following description, certain specific details are set forth in order to provide a thorough understanding of various disclosed embodiments. However, one skilled in the relevant art will recognize that embodiments may be practiced without one or more of these specific details, or with other methods, components, materials, etc. In other instances, well-known structures associated with transmitters, receivers, or transceivers and/or medical equipment and medical facilities have not been shown or described in detail to avoid unnecessarily obscuring descriptions of the embodiments.

[0083] Unless the context requires otherwise, throughout the specification and claims which follow, the word "comprise" and variations thereof, such as, "comprises" and "comprising" are to be construed in an open, inclusive sense, that is as "including, but not limited to."

[0084] Reference throughout this specification to "one embodiment" or "an embodiment" means that a particular feature, structure or characteristic described in connection with the embodiment is included in at least one embodiment. Thus, the appearances of the phrases "in one embodiment" or "in an embodiment" in various places throughout this specification are not necessarily all referring to the same embodiment. Further more, the particular features, structures, or characteristics may be combined in any suitable manner in one or more embodiments.

**[0085]** As used in this specification and the appended claims, the singular forms “a,” “an,” and “the” include plural referents unless the content clearly dictates otherwise. It should also be noted that the term “or” is generally employed in its sense including “and/or” unless the content clearly dictates otherwise.

**[0086]** The headings and Abstract of the Disclosure provided herein are for convenience only and do not interpret the scope or meaning of the embodiments.

**[0087]** Many of the embodiments described herein, perform interrogation and detection of transponder tagged objects using multiple antennas (e.g., six antennas). Successive ones of the antennas may be used to transmit an interrogation signal, while two or more antennas are monitored for a response to the interrogation signal. Such may provide significant advantages over more conventional methods, for example motion based methods that employ motion (e.g., sweeping) of an antenna (e.g., wand) over a patient. For instance, this allows the transmit and receive paths to the transponder to be different from one another (e.g., transmit path is from a first antenna to a transponder, while the receive path is from the transponder to a second antenna). Hence, the path length to the transponder may be shortened in many configurations, thus improving the signal. For instance, when using a single antenna to both transmit an interrogation signal and to receive a response to the interrogation signal, the power of the received signal is equal to about the 6<sup>th</sup> root of the input power. However, when using multiple antennas to transmit and receive over the same area, interrogation path length in one direction may be shorter. Another advantage is that all scan time is averaged, allowing a longer noise time averaging (e.g., 10 seconds) as opposed to motion based scanning, where integration time may be limited (e.g., about 0.25 seconds per sample). Even further, a representative value of noise samples measured over a plurality of antennas may be employed to determine noise to be removed from noise plus signals received at one of the antennas, thereby advantageously lowering a noise floor and/or increasing range or performance. Thus, the various disclosed embodiments may provide significantly better performance.

**[0088]** FIGS. 1 and 2 show a medical procedure environment 10 in which medical procedures are performed, for example a surgical environment in which surgeries are performed, a patient room in which child birth deliveries or other medical procedures are performed or a physician's office, etc. The medical procedure environment 10 includes a table (e.g., surgical table), bed, or other structure 12 which can carry a patient or portion thereof and an interrogation and detection system 14. The interrogation and detection system 14 includes a plurality of antennas 16a-16f (collectively 16, shown in broken line in FIG. 1 to indicate that such are hidden in that view) which are carried by the patient support surface 12. The interrogation and detection system 14 also includes a controller 18 communicatively coupleable to the antennas 16 by one or more wired or wireless communication paths, for example coaxial cable 20. As discussed in detail below, the interrogation and detection system 14 is operable to ascertain the presence or absence of objects 22a, 22b (collectively 22) tagged with transponders 24a, 24b (collectively 24), which may be in or on a patient (not shown).

**[0089]** The table, bed or other structure 12 may include a patient support structure 26 and a pedestal or base 28 which

supports the patient support structure 26. The patient support structure 26 should have dimensions sufficient to support at least a portion of a patient during a medical procedure, for instance during surgery, child birth, etc. Hence, the patient support structure 26 may have a length of six feet or more and a width of two feet or more. The patient support structure 26 may have two or more articulated sections 26a-26c, as illustrated in FIG. 1 or 2, or may be an unarticulated or unitary structure as illustrated in FIGS. 4, 7 and 9. Hinges 30a, 30b (collectively 30) or other coupling structures may couple the articulated sections 26a-26c. The hinges 30 may, for example, be located along a longitudinal axis 32 of the patient support structure 26 at locations that would approximate the anticipated position of a between a patient's legs and torso and between the patient's torso and head.

**[0090]** The patient support structure 26 is preferably made of a rigid material and is preferably radiolucent. Various radiolucent materials may be employed, for instance carbon fiber or radiolucent plastics. Such advantageously allows radiological technologies to be employed, for example X-ray imaging. For example, the patient support structure 26 may be molded from plastics such as an acrylic or a phenolic resin (e.g., commercially available under the trademark SPAULDITE®). In some embodiments, the patient support structure 26 may include a frame. The frame may be made of a metal which may not be radiolucent. In such embodiments, the frame preferably makes up a small percentage of the total area of the patient support structure 26. The patient support structure 26 may be capable of withstanding multiple cycles of sterilization (e.g., chemical, heat, radiation, etc.). A large variety of surgical tables, patient beds and other structures capable of carrying a patient or a portion of a patient are commercially available. Many of these commercially available structures include electric motors and electronics. Typically, there is no or minimum regulation of non-ionizing electromagnetic radiation generated by such electric motors and electronics. Hence, many environments 10 in which medical procedures are performed tend to be electromagnetically noisy environments.

**[0091]** The table, bed or other structure 12 may include one or more mattresses or pads 34a-34c (collectively 34), and/or may include one or more sheets (not shown in FIG. 1 for sake of clarity of illustration). The mattresses or pads 34 and/or sheets may overlie the antennas 16. The mattresses or pads 34 may take a variety of forms, and may be disposable, or may be capable of withstanding multiple cycles of sterilization (e.g., chemical, heat, radiation, etc.). The mattresses or pads 34 are preferably radiolucent. The mattresses or pads 34 may take a conventional form, for example cotton, open cell or a closed cell foam rubber, with or without an appropriate cover. Alternatively, the mattresses or pads 34 may include one or more bladders (e.g., dual layer urethane envelope) to receive a fluid (e.g., air, water, etc.) to selectively inflate one or more portions of the mattresses or pads 34, and/or to control a temperature of one or more portions of the mattresses or pads 34. In such embodiments, the fluid should be radiolucent. The mattresses or pads 34 may be detachably secured to the patient support structure 26 via various fasteners, for instance ties, or hook and loop fastener commonly available under the trademark VELCRO®.

**[0092]** The pedestal or base 28 may be fixed, or may be moveable. The pedestal or base 28 may include one or more

actuators (e.g., motors, pumps, hydraulics, etc.) and/or drive mechanisms (e.g., gears, mechanical couplings) or linkages (not shown) that allow a position and/or orientation of the patient support structure 26 to be adjusted. For example, the pedestal or base 28 may telescope to allow the patient support structure 26 to be mechanically raised and lowered. Also for example, the pedestal or base 28 may allow the patient support structure 26 to be mechanically tilted or rotated about an axis that is perpendicular to a patient support surface 37 of the patient support structure 26.

**[0093]** As illustrated, portions of one or more of the antennas 16 may overlap. For example, where the antennas are coil antennas, each formed of one or more coils, a portion of an area enclosed by an outermost coil of each antenna 16 may overlap a portion of an area enclosed by an outermost coil of a neighboring antenna 16. The area enclosed or enclosed area may be an area enclosed by a normal or perpendicular projection of a perimeter defined the outermost coil of the respective antenna 16. In such embodiments, neighboring antennas 16 may be electrically insulated from one another by one or more electrically insulating layers or substrates. For example, successively adjacent antennas 16 may be carried on opposite surfaces (e.g., opposed outer surfaces, or multiple inner surfaces, or one or more outer and inner surfaces) of a single substrate. As discussed in more detail below, the antennas may advantageously be radiolucent, for example being formed of a radiolucent material (e.g., substantially transparent to X-ray or Gamma ray radiation) or a material that at a thickness employed is substantially radiolucent. For example, an electrically conductive trace of aluminum having a thickness of 200 microns or less sufficiently passes X-rays to be considered radiolucent. More preferably, an aluminum trace having a thickness of 30 microns sufficiently passes X-rays such that even a stack or overlapping portions of three coils (combined thickness under 100 microns) to be radiolucent. An antenna may be considered radiolucent if it is not detectable by a radiologist in an X-ray produced via 10 kV to 120 kV X-ray machine, or preferably a 40 KV X-ray machine in conjunction with a standard 12 inch X-ray image intensifier. An antenna may be considered radiolucent if a coil includes thirty turns or windings and is not detectable by a radiologist in an X-ray.

**[0094]** The patient support structure 26 may include one or more film receiving receptacles 29 (only one called out in FIG. 1). The film receiving receptacles 29 may be spaced relatively below a patient support surface 37 of the patient support structure 26. The film receiving receptacles 29 are sized, dimensioned and/or positioned to receive film, for example X-ray film. The film receiving receptacles 29 may be sized and/or dimensioned to receive a film tray or other film holder (not illustrated) which holds the film. Along with the use of radiolucent materials, such advantageously allows a patient X-ray images or other radiological images of the patient to be produced, generated or made, while the patient is supported by the patient support structure 26. As used herein in the claims, the term radiolucent means substantially transmissive to energy in the X-ray portion of the electromagnetic spectrum, that is passing sufficient X-ray energy to produce an X-ray image at standard power levels and standard conditions employed in conventional medical imaging.

**[0095]** The table (e.g., surgical table), bed or other structure 12 may include an interrogation and detection system

interface 36. The interrogation and detection system interface 36 may include one or more communications ports 38 that allow communicative coupling to be selectively or detachably made between the antennas 16 and the controller 18. Such communications ports 38 may, for example, take the form of coaxial connectors, or other communications connectors. Interrogation and detection system interface 36 may include one or more output devices to provide indications to a user. For instance, the interrogation and detection system interface 36 may include one or more visual indicators 40 (only one called out in FIGS. 1 and 2) to provide indications of a presence and/or an absence of an object. Such may also provide a visual indication that is indicative of a status of a scanning operation by the interrogation and detection system 14, for instance scanning started, scanning completed, and/or occurrence of an error condition. The visual indicators 40 may take a variety of forms, for example light sources of one or more colors. Light sources may include incandescent lights, light emitting diodes (LEDs), organic light emitting diodes (OLEDs), and/or liquid crystal displays (LCDs). Also for instance, the interrogation and detection system interface 36 may include one or more aural indicators 42 to provide aural indications of a presence and/or an absence of an object and/or a status of a scan operation or occurrence of an error condition. The aural indicator 42 may, for example, take the form of one or more speakers. The interrogation and detection system interface 36 may include one or more switches 44 that allow input to be provided to the controller 18. Switches 44 may, for example, allow a user to turn ON the interrogation and detection system 14, start a scan operation, stop a scan operation, adjust a sensitivity of the scanning, adjust one or more frequencies, select or adjust an output type (e.g., type of visual alert, type of aural alert) or level (e.g., brightness, sound level or volume, etc.).

**[0096]** The objects 22 may take a variety of forms, for example instruments, accessories and/or disposable objects useful in performing medical procedures, for example surgical procedures, child birth delivery procedures, and/or other medically related procedures. For instance, some objects 16a may take the form of scalpels, scissors, forceps, hemostats, and/or clamps. Also for example, some objects 22b may take the form of sponges (e.g., surgical sponges), gauze and/or padding. The objects 22 are tagged, carrying, attached or otherwise coupled to a respective transponder 24. Some embodiments of the interrogation and detection system 14 disclosed herein are particularly suited to operate with transponders 26 which are not accurately tuned to a chosen or selected resonant frequency. Consequently, the transponders 24 do not require high manufacturing tolerances or expensive materials, and thus may be inexpensive to manufacture.

**[0097]** Transponders 24 may include a miniature ferrite rod with a conductive coil wrapped about an exterior surface thereof to form an inductor (L), and a capacitor (C) coupled to the conductive coil to form a series LC circuit. The conductive coil may, for example, take the form of a spiral wound conductive wire with an electrically insulative sheath or sleeve. The transponder 24 may include an encapsulation that encapsulates the ferrite rod, conductive coil, and capacitor. The encapsulant may be a bio-inert plastic, that protects the ferrite rod, conductive coil and/or capacitor from pressure and/or from fluids, for example bodily fluids. In some embodiments, the ferrite rod may include a passage sized to

receive a physical coupler, for example a bonding tie or string. The bonding tie or string may take the form of an elastomeric x-ray opaque flexible elongated member, that may be used to attach the transponder **24** to various types of objects **22**, for example surgical sponges. The transponder **24** may have a length of about 8 millimeters and a diameter of about 2 millimeters. Employing such small dimensions ensures that the transponder **24** does not impede deformation of objects **16** such as sponges. The transponder **24** may include an optional diode (not shown), to protect against over-voltage occurrences caused by other electronic instruments. The transponders **24** may be attached to hemostats, scissors, certain forms of forceps, and the like. In some embodiments, the transponders **24** may be coupled to the object **22** by way of a clamp or holder. In some embodiments, the transponders **24** may be retained within a cavity of the holder. In some embodiments, the holder may be fashioned of a durable deformable material, such as surgical grade polymer, which may be deformed to clamp securely onto the finger or thumbhole of an instrument. In other embodiments, the transponders **24** may be attached to objects **22** by way of pouches fashioned of sheet material (e.g., surgical fabric) surrounding the transponder **24**. The transponder **24** is retained within the pouch, and in some embodiments the pouch may be sewn or otherwise sealed. Sealing may be done with adhesive, hot glue, clamping, grommets, or the like. Various embodiments of suitable transponders and retention devices are discussed in U.S. Provisional Patent Application No. 60/811,376 filed Jun. 6, 2006, U.S. Provisional Patent Application No. 61/091,667 filed Aug. 25, 2008, U.S. patent application Ser. No. 11/759141 filed Jun. 6, 2007, U.S. patent application Ser. No. 12/046,396 filed Mar. 11, 2008, U.S. Pat. No. 6,026,818 issued Feb. 22, 2000, U.S. Design patent application Ser. No. 29/322,539 filed Aug. 6, 2008 and U.S. Design Pat. No. D568,186 issued May 6, 2008, all of which are incorporated herein by reference in their entireties.

[0098] In use, the medical provider **12** may use the switches **44** to cause a scan of the patient **18**, for instance just before closing during surgery, in order to detect the presence or absence of the transponder **26**, and hence an object **16**.

[0099] FIG. 3 shows approximate ranges  $R_1$ - $R_6$  for the six antennas **16** of the embodiment of FIGS. 1 and 2.

[0100] FIG. 3 is illustrative and does not necessarily represent actual ranges. The illustrated ranges  $R_1$ - $R_6$  (collectively  $R$ ) show that the ranges  $R_1$ - $R_6$  are typically larger than the area of the antennas **16**. Ranges  $R_1$ - $R_6$  may be affected by a variety of factors, including the power of the interrogation signal, distance between the transponders **24** and the antennas **16**, and/or the sensitivity and/or impedance matching between the transponders **24** and interrogation and detection system **14**. Many of the ranges  $R_1$ - $R_5$  overlap neighboring ranges  $R_1$ - $R_5$ , although in this illustrated embodiment one range  $R_6$  does not overlap any other range  $R_1$ - $R_5$ . In other embodiments, all ranges overlap. Alternatively, none of the ranges may overlap. Other arrangements of antennas **16** and/or ranges  $R$ , are of course possible.

[0101] FIGS. 4, 5A and 5B show a patient support structure **626**, according to another illustrated embodiment.

[0102] The patient support structure **626** may, for example, be part of a table, for instance a surgical table, part of a bed or another structure designed to carry a patient or portion of a patient. The patient support structure **626** is a non-articulated, single piece or unitary structure. While

illustrated as a single, unitary construction, the patient support structure **626** may be formed of two or more sections, which may or may not be articulated. The patient support structure **626** is formed as a substrate **650** having a patient support surface **637** and an opposed surface **652** that is opposed from the patient support surface **637**. The substrate **650** may be formed of one or more layers. For example, the substrate **650** may be a composite material. The substrate **650** may, for example, be formed as a resin impregnated carbon fiber structure, which may advantageously omit any metal or ferrous metal structural elements. Alternatively, the substrate **650** may minimize the use of any metal or ferrous metal structural elements and locate any metal or ferrous metal structural elements at the peripheries of the substrate **650**.

[0103] A first set of antennas **616a**, **616c**, **616e**, **616g** are positioned on the patient support surface **637**, while a second set of antennas **616b**, **616d**, **616f** are positioned on the opposed surface **652**. Such allows neighboring ones of the antennas (collectively **616**), or portions thereof, to overlap, while electrically insulating each antenna **616** from one another. While illustrated as being carried on outer surfaces of the patient support structure **650** one or more of the antennas **616** could be carried on one or more inner layers of the patient support structure **650** where the patient support structure **650** is formed of two or more layers, for instance as a laminate structure.

[0104] FIGS. 6A-6C show a patient support structure **626** and antennas **616a-616h** (collectively **616**), according to another illustrated embodiment, wherein individual ones of the electrically conductive paths or traces of the antennas **616** are visible.

[0105] The patient support structure **626** may, for example, be part of a table, for instance a surgical table, part of a bed (e.g., patient or hospital bed) or another structure designed to carry a patient or portion of a patient on which a medical procedure may be performed. The patient support structure **626** is a non-articulated, single piece or unitary structure. While illustrated as a single, unitary construction, the patient support structure **626** may be formed of two or more sections, which may or may not be articulated. The patient support structure **626** is formed as a substrate **650** having a patient support surface **637** and an opposed surface **652** that is opposed from the patient support surface **637**. The substrate **650** may be formed of one or more layers. For example, the substrate **650** may be a composite material. The substrate **650** may, for example, be formed as a resin impregnated carbon fiber structure, which may advantageously omit any metal or ferrous metal structural elements. Alternatively, the substrate **650** may minimize the use of any metal or ferrous metal structural elements and locate any metal or ferrous metal structural elements at the peripheries of the substrate **650**.

[0106] The patient support structure **626** carries antennas **616** thereon and/or therein. As best illustrated in FIGS. 6A and 6B, the antennas can be treated as two sets. A first set of antennas **616a-616f** arranged generally adjacent one another in an array of two rows on either side of a longitudinal axis **630** and three columns spaced along the longitudinal axis **630**. These antennas **616a-616f** do not overlap with one another. These antennas **616a-616f** substantially extend the full length and width of the patient support structure **628**. Alternatively, these antennas **616a-616f** may be spaced inwardly from a perimeter of the patient support structure,

for example where the range of the antennas **616a-616f** sufficiently covers the area of the patient support structure **626**. A second set of antennas **616g, 616h** are arranged generally adjacent one another in an array of one row and two columns. These antennas **616g, 616h** do not overlap with one another, however these antennas **616g, 616h** overlap the antennas **616a-616f** of the first set when viewed from above the patient support structure **626**. These antennas **616g, 616h** enhance the overall coverage of the entire area of the patient support structure **626** and volume spaced generally there above.

[0107] While illustrated as being carried an upper outer surface **637** of the patient support structure **626**, one or more of the antennas **616** could be carried on a lower outer surface **652** and/or on one or more inner layers of the patient support structure **626**, for instance where the patient support structure **626** is a laminate structure.

[0108] FIG. 6C shows one embodiment of the antennas **616**, which may allow relatively simple and low cost manufacturing, and which prevents the antennas **616** from electrically shorting one another.

[0109] In particular, each antenna may be formed as electrically conductive paths or traces on one or more layers of an electrically non-conductive or insulative substrate, for instance a flexible substrate of circuit board material (e.g. FR4, Kapton). The electrically conductive path or trace may form a coil pattern, hence a coil antenna with multiple windings, as illustrated in FIG. 6C. Portions of the electrically conductive path on one end or half of the substrate may be electrically coupled to respective portions of the electrically conductive path on the other end or half of the substrate via electrically conductive material received in a via that extends through a portion or all of the substrate. Thus, while the electrically conductive paths appear to terminate at a centerline **647** of each antenna, the electrically conductive paths are in fact electrically coupled to adjacent portions across the centerline **647** by way of respective vias. Alternatively, the electrically conductive path may have change in direction (e.g., 45 degree turn), such that the electrically conductive path spirals inwardly (or outwardly) with each half turn or half winding. Alternatively, or additionally, an electrically non-conductive or electrically insulative material may overlie the electrically conductive path on a lower surface or side and/or an upper surface or side of the substrate, to provide electrical insulation between overlying substrates.

[0110] FIG. 7 shows a patient support structure **726**, according to another illustrated embodiment.

[0111] The patient support structure **726** is formed as a substrate **750** having a patient support surface **737** and an opposed surface **752** that is opposed from the patient support surface **737**. The substrate **750** may be formed of one or more layers. For example, the substrate **750** may be a composite material. The substrate **750** may, for example, be formed as a resin impregnated carbon fiber structure, which may advantageously omit any metal or ferrous metal structural elements. Alternatively, the substrate **750** may minimize the use of any metal or ferrous metal structural elements and locate any metal or ferrous metal structural elements at the peripheries of the substrate **750**. While illustrated as a single, unitary construction, the patient support structure **726** may be formed of two or more sections, which may or may not be articulated.

[0112] A first set of antennas **716a, 716c, 716e, 716g** are positioned in respective recesses formed in the patient support surface **737**, while a second set of antennas **716b, 716d, 716f** are positioned in respective recesses formed in the opposed surface **752**. Such allows neighboring ones of the antennas (collectively **716**) to overlap, while electrically insulating each antenna **716** from one another. Such also advantageously spaced the antennas **716** of the first and second sets closer together with respect to one another, which may produce more consistent results or performance between the various antennas **716**. While illustrated as being carried on outer surfaces of the patient support structure **750** one or more of the antennas **716** could be carried on one or more inner layers of the patient support structure **750** where the patient support structure **750** is formed of two or more layers, for instance as a laminate structure.

[0113] FIG. 8A shows a patient support structure **826A**, according to another illustrated embodiment.

[0114] The patient support structure **826A** is a non-articulated, single piece or unitary structure. While illustrated as a single, unitary construction, the patient support structure **826A** may be formed of two or more sections, which may or may not be articulated. The patient support structure **826A** may be formed of a variety of materials, for example, the materials of the above described embodiments.

[0115] Notably, the patient support structure **826A** carries a set of antennas **816Aa-816Af** (collectively **816A**), which are positioned along a longitudinal axis **830** of the patient support structure **826A**. While illustrated as positioned in non-overlapping fashion, in some embodiments the antennas **816A** may be positioned in overlapping fashion. While five antennas **816B** are illustrated, the patient support structure **826A** may include a greater or lesser number of antennas **816A**. Consequently, the antennas **816A** may all be carried on the same outer surface (e.g., patient support surface) or inner surface or layer. Thus, may advantageously provide more consistent results or performance between the respective antennas **816**, and/or may simply manufacturing and/or maintenance.

[0116] FIG. 8B shows a patient support structure, according to another illustrated embodiment.

[0117] The patient support structure takes the form of a mattress or pad **826B** which may, for example, be used on a table or bed when performing a medical procedure. While illustrated as an articulated structure with two joints or hinges **830Ba, 830Bb** (collectively **830B**), the mattress or pad **826B** may be formed of a unitary, single piece non-articulated structure. The mattress or pad **826B** may be reusable, and hence should be capable of withstanding repeated sterilization procedures (e.g., heat, chemical, radiation, etc.). Alternatively, the mattress or pad **826B** may be disposable after a single use. The mattress or pad **826B** may be formed of a variety of materials, for example, the materials of the above described embodiments of mattresses or pads. As previously discussed in reference to mattresses or pads, the mattress or pad **826B** may include an outer layer or cover **892B** and an interior **890B** (visible through broken portion of outer layer **892B**). The outer layer or cover **892B** provides environmental protection to the interior **890B**. The interior **890B** may, for example, take the form of a conformable interior, which may be made of any variety of materials. Suitable material may, for example, include cotton or a foam material such as a closed or an open cell foam rubber or LATEX®. Alternatively, the conformable interior

may take the form of a fluid (e.g., a liquid or a gas). The outer layer or cover **892B** may be made of cotton, nylon, rayon or other natural or synthetic materials. The outer layer or cover **892B** may, for example, be impervious to liquids. For example, the outer layer or cover **892B** may include one or more layers of a rubber, LATEX®, polyvinyl chloride, plastic or other material that is impervious to fluids, for example bodily fluids.

[**0118**] Notably, the mattress or pad **826B** carries a set of antennas **816Ba-816Be** (collectively **816B**), which are positioned along a longitudinal axis **832B** of the mattress or pad **826B**. While illustrated as positioned in overlapping fashion, in some embodiments the antennas **816B** may be positioned in non-overlapping fashion. While five antennas **816B** are illustrated, the mattress or pad **826B** may include a greater or lesser number of antennas **816B**. For example, the mattress or pad **826B** may have antennas **816** arranged in a similar fashion to that illustrated in FIGS. 6A-6C. The antennas **816B** may on opposite sides of a layer on or in the mattress or pad **826B**, or on two or more different layers on or in the mattress or pad **826B**. The layer or layers may be an outer surface (e.g., patient support surface) or an inner surface or layer. The mattress or pad **826B** includes an interface, such as a connector **894B**, to allow the antennas **816B** to be communicatively coupled to the controller **18** (FIG. 1).

[**0119**] FIG. 8C shows a patient support structure, according to another illustrated embodiment.

[**0120**] The patient support structure takes the form of a sheet **826C**. The sheet **826C** may, for example, be used on, over, or in conjunction with a table, bed, frame or other structure during a medical procedure. The sheet **826C** may be formed of a unitary, single piece of material or a cloth, for example a fabric. The cloth may, for example, be woven, knitted, felted, pressed, etc. The sheet **826C** may be reusable, and hence should be capable of withstanding repeated sterilization procedures (e.g., heat, chemical, radiation, etc.). Alternatively, the sheet **826C** may be disposable after a single use. The sheet **826C** may be absorbent or may be impermeable to fluids, for example bodily fluids. The sheet **826C** may be formed of a variety of materials, for example, cotton, nylon, rayon, or other natural or synthetic fibers. For example, the sheet **826C** may include one or more layers of a rubber, LATEX®, polyvinyl chloride, plastic or other material that is impervious to fluids, for example bodily fluids.

[**0121**] Notably, the sheet **826C** carries a set of antennas **816Ca-816Ce** (collectively **816C**), which are positioned along a longitudinal axis **832C** of the sheet **826C**. While illustrated as positioned in overlapping fashion, in some embodiments the antennas **816C** may be positioned in non-overlapping fashion. While six antennas **816C** are illustrated, the sheet **826C** may include a greater or lesser number of antennas **816C**. For example, the antennas **816** may be arranged on the sheet **826** in an identical or similar fashion as illustrated in FIGS. 6A-6C. The antennas **816C** may be on opposite sides of the sheet **826C**, or on two or more different layers of the sheet **826C**. The layer or layers may be an outer surface (e.g., patient support surface) or an inner surface or layer. The sheet **826C** includes an interface, such as a connector **894C**, to allow the antennas **816C** to be communicatively coupled to the controller **18** (FIG. 1).

[**0122**] FIG. 9 shows an antenna **916**, according to one illustrated embodiment. The antenna **916** may, for example, be suitable for use in any of the previously described embodiments.

[**0123**] The antenna **916** may, for example, take the form of an annulus or air-coil formed of coils of conductive material. The conductive material may, for example, take the form of wire or may take the form of a conductive trace printed or otherwise deposited on an inner layer or an outer surface **952** of a substrate **950**. In one embodiment, the antenna **916** includes ten turns evenly spaced between an inner diameter of about 11 inches and an outer diameter of about 14 inches. The antenna **916** acts as an inductor. While being formed of a conductive material, the antenna **916** is preferably formed of a radiolucent material. For example, the antenna **916** may be formed as a thin (e.g., thickness, width) strip line aluminum antenna.

[**0124**] The antenna **816** includes a pair of terminals **854a**, **854b** that provide electrical coupling to the controller **18** (FIG. 1), for example via the ports **38** of interrogation and detection system interface **36** (FIGS. 1 and 2) and the coaxial cable **20**.

[**0125**] FIGS. 10A-10C illustrate a coil antenna **1016** according to one embodiment.

[**0126**] The coil antenna **1016** comprises a top coil **1017** (illustrated in isolation in FIG. 10B) and a bottom coil **1019** (illustrated in isolation in FIG. 10C). The top and bottom coils **1017**, **1019** are carried by the patient support surface **26**, the top coil **1017** carried on one layer **1021a** and positioned relatively above the bottom coil **1019** carried on another layer **1021b**. The top coil **1017** is electrically coupled to the bottom coil **1019**, for example, by a plug of electrically conductive material **1015** in a via. In practice the via connecting the top coil **1017** to the bottom coil **1019** may comprise a vertical connector of the same material as the coils **1017**, **1019**. Any suitable conductor may be used to connect the top coil to the bottom coil at the via point. In addition to being offset from each other vertically along a longitudinal axis **1018** of the coils (see FIG. 10D), the individual windings of the two coils are also offset from each other laterally along two perpendicular axes in a horizontal plane (i.e., the plane of the drawing sheet FIG. 10A) that is perpendicular to the longitudinal axis. The layers **1021a**, **1021b** may be opposed outer surfaces of an electrically insulative substrate, one or more inner surfaces of the electrically insulative substrate, or a combination thereof. The electrically insulative substrate may be a unitary part of the patient support surface, integral part of the patient support surface or attach or carried by the patient support surface.

[**0127**] FIG. 10D shows the coil antenna **1016** carried by a patient support structure **26**, according to one illustrated embodiment.

[**0128**] Top coil **1017** is positioned relatively above the bottom coil **1019** in an interior of the patient support structure **26**. As noted above, the bottom coil **1019** is offset from the top coil **1017** vertically along a longitudinal axis **1018** as well as laterally in a horizontal plane which is perpendicular to the longitudinal axis **1018**. The individual windings **1021** of the top coil **1017** are spaced apart leaving gaps between each winding **1021**. The individual windings **1023** of the bottom coil **1019** are spaced directly below the gaps between the windings **1021** of the top coil **1017**. The windings **1021**, **1023** are thus spread in such a way to

provide a more even distribution of radiolucence. This distribution of the windings **1021**, **1023** may smooth the contrast that could appear in a radiological image (e.g., X-ray image). FIG. **10D** illustrates an embodiment in which the windings **1023** are spaced directly below the gaps between windings **1021** without overlapping the windings **1021** in a lateral direction in the horizontal plane. In other embodiments the windings **1023** may instead slightly overlap the windings **1021**. In some embodiments the windings **1021**, **1023** may cross over each other although such crossings may have an adverse effect on radio transparency. Many other configurations of the coils **1017**, **1019** and the windings **1021**, **1023** will be apparent to those of skill in the art and fall within the scope of this disclosure. The configuration of windings illustrated in FIG. **10D** are given only by way of example and do not limit the scope of the disclosure. The patient support structure **26** and antenna **1016** are not drawn to scale. Relative heights, widths, and separations of the patient support structure **26** and antenna coils **1017**, **1019** may be different in practice than what is shown in FIG. **10D**.

[**0129**] This design may minimize interference with radiological imagery sources (e.g., X-rays, CAT scans, MRIs) which may be employed while a patient is on the patient support structure **26**. Radiological imaging is commonly employed while patients are on the patient support structure **26**, for example during surgery. This may, for example, be performed by positioning an X-ray machine above the patient support structure **26** and positioning an X-ray sensitive film below the patient support structure **26**. An X-ray image is formed by exposing the film to the X-rays through the patient and patient support structure **26**. Any object or material that absorbs or reflects X-rays more than its surroundings will cause an area of contrast in the developed X-ray image. Thus, portions of the patient support structure **26** that absorb more or less than other portions of the patient support structure **26** will appear as a high level of contrast in the developed X-ray image. This can make it difficult to interpret the X-ray image. For this reason it may be beneficial to spread the coils of an antenna, even where nominally radio transparent to reduce the contrast which the antenna may otherwise cause in an X-ray image. A coil antenna with many windings which are stacked or layered are above others may produce a relatively high contrast and appear in an X-ray image even if a single layer of coil is nominally radio transparent. A coil whose windings are spread apart, spread laterally from one another, may also produce relatively large changes in contrast, even where nominally radio transparent. As disclosed herein, the windings of the coils are positioned to be in adjacent non-overlapping relationship to one another when viewed along the longitudinal axis **1018**. Such creates an area having a very uniform distribution of antenna material, and hence a very uniform radiological attenuation distribution across that area. Such advantageously may cause any attenuation to be uniform, reducing the antenna's effect on the radiological image.

[**0130**] FIGS. **10E** and **10F** show a patient support structure **26** according to one embodiment.

[**0131**] The patient support structure carries six antennas **1016a-1016f**. Each of the antennas **1016a-1016f** may be similar or identical in form to the antenna **1016** illustrated in FIG. **10A-10D**. The antennas **1016a-1016f** are positioned to provide little or no gap between antennas in the lateral directions of the horizontal plane of the patient support

surface **26**, while not overlapping. As described above, this configuration may help to reduce areas of sharp contrast in radiological images. FIG. **10E** shows the antennas **1016a-1016f** embedded within the patient support structure **26**. Of course the antennas **1016a-1016f** may not actually be visible from a top view of the support structure **26**. However, FIG. **10F** shows the antennas **1016a-1016f** from the top view to illustrate the relative positions of the antennas **1016a-1016f**. The number and configuration of coils, as well as the number and configuration of the winding forming those coils, shown in FIG. **10F** is not meant to be limiting. In practice there may be a greater or lesser number of coils and/or a greater or lesser number of windings. In practice, the windings are typically not independent loops, but are illustrated as such in FIG. **10F** for ease of illustration.

[**0132**] FIG. **11** shows a patient support structure carrying an antenna **1116**, according to another illustrated embodiment.

[**0133**] The antenna **1116** comprises a top coil **1117** and a bottom coil **1119** as previously described. The top coil **1117** comprises windings **1121**, while the bottom coil comprises windings **1123**. The windings **1121**, **1123** are laterally offset from each other in two perpendicular directions in a horizontal plane that is perpendicular to a longitudinal axis of the antenna **1116**. The top coil **1117** is formed adjacent to and below a top surface **1137** of the support structure **26**, for example in a channel or recess formed in the top section **1137**. The bottom coil **1119** is formed above and adjacent to a bottom surface **1152** of the support structure **26**, for example, in a channel or recess formed in the bottom section **1152**.

[**0134**] FIG. **12** illustrates a patient support structure that carries an antenna **1216**, according to yet another illustrated embodiment. The antenna **1216** comprises a top coil **1217** and a bottom coil **1219**. The top coil **1217** comprises windings **1221**, while the bottom coil comprises windings **1223**. The windings **1221**, **1223** are laterally offset from each other in a horizontal plane that is perpendicular to a longitudinal axis of the antenna **1216**. The top coil **1217** is carried directly on a top surface **1237** of the support structure **26**. The bottom coil **1219** is carried directly on a bottom surface **1252** of the support structure **26**. The top and/or bottom coils **1217**, **1219** may be adhered or otherwise physically coupled to the respective surfaces **1237**, **1252**. The relative dimensions of the features shown in FIG. **12** may not be accurate. For instance, the antenna windings **1221**, **1223** may not, in practice, protrude from the surfaces **1237**, **1252** to the same extent as illustrated. Many other configurations for the antennas are possible and the preceding embodiments are given only by way of non-limiting example.

[**0135**] FIG. **13A** shows a surgical environment **1310** that includes a surgical table **1312** and an interrogation and detection system **1314**, according to another illustrated embodiment. The embodiment of FIG. **13A** is similar in some respects to one or more of the previously described embodiments, hence only significant differences in structure and operation will be discussed.

[**0136**] The surgical table **1310** may include a patient support structure **1326** and a pedestal or base **1328**. The patient support structure **1326** may be a laminate structure having multiple layers. Alternatively, the patient support structure **1326** may be a shell type structure or housing

having an open interior. Alternatively, the patient support structure 1326 may be a solid structure, for example a roto-molded structure.

[0137] The plurality of antennas 1316a-1316f (collectively 1316) of the interrogation and detection system 1314 are carried by the surgical table 1312, for example carried by inner layers of the patient support structure 1326 or positioned in an interior of a shell or housing forming the patient support structure 1326. While illustrated as being in overlapping relationship, in some embodiments the antennas 1316 may not overlap. The controller 1318 of the interrogation and detection system 1314 may be positioned in the pedestal or base 1328, for example in an interior 1330 of the pedestal or base 1328. One or more wired or wireless communication paths may communicatively couple the controller 1318 to the antennas 1316 and/or to an interrogation and detection system interface 1336, for example coaxial cable 1320.

[0138] The interrogation and detection system 1314 may receive power for a variety of sources, for example from a wall outlet or receptacle via a conventional power cord and plug 1332.

[0139] The antennas of the interrogation and detection system 14 are not limited to being implemented in a patient support structure 26. Previous embodiments have, by way of example, described various ways of implementing antennas within a patient support structure. These embodiments have been given purely by way of example and are not intended to be limiting. Those of skill in the art will recognize that the antennas may be implemented in many configurations throughout the environment in which medical procedures are performed.

[0140] FIG. 13B shows an environment in which medical procedures are performed 1340 that includes a bed (e.g., patient bed) 1342 and an interrogation and detection system 1344, according to another illustrated embodiment. The embodiment of FIG. 13B is similar in some respects to one or more of the previously described embodiments, hence only significant differences in structure and operation will be discussed.

[0141] The environment 1310, may for example, take the form of a hospital room, clinic room, or examination room of a medical practitioner's office.

[0142] The bed 1342 may include a patient support structure 1346 and a frame or base 1348. The patient support structure 1346 may support one or more mattresses, for example a segmented mattress 1347. The frame 1348 may be made of plastic, metal, composite, reinforced composited, and/or roto-molded materials. Various commercially available designs of frames for patient beds are suitable. The frame 1348 may include a set of wheels 1350 (only one called out in FIG. 13B) allowing the bed 1342 to be easily moved. The frame 1348 may include one or more rails 1352, which may, or may not, be removable or which may, or may not, fold down.

[0143] The bed 1342 may include one or more electric motors 1354 (only one called out in FIG. 13B) and linkages 1356 (only one called out in FIG. 13B) which are selectively actuated to move or articulate portions of the bed 1342 or mattress 1346. Other mechanisms may be used to move portions of the mattress 1346. Commercially available patient or hospital beds 1342 typically include one or more pieces of electrical or electronic equipment (e.g., electric motors 1354) which are sources of radio noise which may

interfere with the interrogation and detection system 1344. Such equipment typically produce very consistent or periodic (i.e., non-random) noise. Some embodiments of the interrogation and detection system 1344 discussed herein employ various techniques to address such non-random noise.

[0144] The interrogation and detection system 1344 includes a plurality of antennas 1366a-1366f (collectively 1366) of the interrogation and detection system 1344 are carried by the patient support structure 1346, mattress 1347 or frame 1348. For example, the antennas 1366 may be carried by inner layers of the mattress 1347 or positioned in an interior of a shell or housing forming the patient support structure 1346. While illustrated as being in non-overlapping relationship, in some embodiments the antennas 1366 may overlap. A controller 1368 of the interrogation and detection system 1344 may be carried by the frame or base 1348. One or more wired or wireless communication paths may communicatively couple the controller 1368 to the antennas 1366 and/or to an interrogation and detection system interface, for example coaxial cable 1370.

[0145] The interrogation and detection system 1314 may receive power for a variety of sources, for example from a wall outlet or receptacle via a conventional power cord and plug (not shown in FIG. 13B).

[0146] In some embodiments, antennas, for instance antennas 1316, 1366 (FIGS. 13A, 13B, respectively) may form strain sensors as part of a strain gauge. For example, the antennas may be carried by flexible substrate, for instance a flexible printed circuit board such as a polyimide (Kapton®) or polyester (Mylar®) printed circuit board. The resistance of the antenna varies as the substrate flexes in response to an asserted force. The change in resistance may be measured to determine strain, and hence force applied. The antennas may be configured and coupled in groups of fours to form full Wheatstone bridges. The antennas may additionally, or alternatively, be oriented along various axes or dimensions to detect strain in different directions. Multiple layers of antennas may be employed to detect flex in two opposite directions, normal to the plane of the substrate. Alternatively, dedicated strain sensors or gauges may be employed, which function only to sense force (e.g., strain or pressure) and which do not function as antennas. Sensing strain may be useful in detecting excessive and/or prolonged pressure asserted between a patient and the patient support surface. Excess and/or prolonged pressure may cause the patient to develop "bed sores" or ulcers. Tracking or monitoring pressure may allow the medical care provider to intervene before the "bed sores" or ulcers occur. Thus, the control system may be configured to provide a warning or alert (e.g., visual, aural and/or tactile) when pressure or strain exceeds some threshold in amplitude and/or time. For instance, the controller may produce a notification if the force exerted on at least one of the antenna exceeds an amplitude threshold over a period of time that exceeds a time duration threshold. The control system may additionally, or alternatively, provide an indication of a position or location on the patient support surface or patient where the excessive pressure is occurring or being asserted. For instance, the controller may display a map of the patient support structure and/or patient, with icons or alphanumeric indications indicative of various locations where excessive force is being asserted and/or an amplitude of force being asserted at respective locations on the map.

[0147] FIG. 14A shows a number of antennas 1416 carried by a lightshade 1432 of a light fixture 1434 used in medical procedures, according to one illustrated embodiment, in which the lightshade is shown in a retracted or undeployed position or configuration. The light fixture 1434 may house one or more lights to be used during surgery, birth delivery or other medical procedure, including dental procedures. During a medical procedure such as surgery, the patient laying on a patient support structure is typically illuminated brightly by an overhead light fixture 1434. The light fixture 1434 may be situated directly above the operating table or slightly offset as desired. The light fixture 1434 is also generally positioned as close to the patient as possible without impeding the medical services providers (e.g., surgeons and staff) during the medical procedure (e.g., surgery, birth delivery). The proximal overhead position allows the light fixture 1434 to brightly illuminate the patient. The light fixture 1434 is positioned so as to reduce or eliminate any shadows on the patient's body during the surgery.

[0148] The proximal overhead position of the light fixture 1434 provides an excellent location for the antennas 1416 of an interrogation and detection system. There are five loop antennas 1416 visible in the lightshade 1432 illustrated in FIG. 14A. However, there may be more antennas 1416 on a far side of the lightshade 1432, not visible in FIG. 14A. The number of antennas 1416 located on the lightshade 1432 may be any number suitable for the interrogation process.

[0149] The lightshade 1432 may be attached to the light fixture 1434 by extendable and retractable support arms 1436. As noted, FIG. 14A illustrates the lightshade 1432 in a retracted or undeployed position or configuration, raised relative to the light fixture 1434. The support arms 1436 may include hinges 1438 or other linkages. The hinges 1436 or other linkages enable the lightshade 1432 to be moved to an extended or deployed position or configuration, lowered relative to the light fixture 1434 and the patient support surface, for example, as illustrated in FIG. 14B. In one embodiment the antennas 1416 of the lightshade 1432 may be operable in the raised position. In one embodiment the antennas 1416 may be attached to the light fixture 1434 in a form other than that of a lightshade 1432.

[0150] FIG. 14C shows a lightshade 1432 is coupled to the light fixture 1434 without the use of supporting arms 1436, according to yet another illustrated embodiment.

[0151] The lightshade 1432 may be a flexible sheet carrying a number of antennas 1416. The flexible sheet is coupleable to the light fixture 1434 by wrapping the flexible sheet around the light fixture 1434 and securing the flexible sheet thereto. The lightshade 1432 may be attached to the light fixture 1434 by hooks, hook-and-loop fasteners (e.g., VELCRO®), clips, or any other suitable fasteners or adhesives. Two ends of the lightshade 1432 may be attached to each other to create an opening sized to securely receive a portion of the light fixture 1434 therein. In this configuration the lightshade 1432 remains on the light fixture by virtue of having a smaller diameter opening than a diameter of the portion of the light fixture. The lightshade 1432 may alternatively be an integral part of the light.

[0152] In one embodiment, the antennas 1416 of the lightshade 1432 are communicatively coupled to an interrogation and detection system interface 36. The interrogation and detection system interface 36 may be located at any suitable position in the room or in another room. The antennas 1416 may be connected to the system interface 36

by a wired connection (e.g., wire bundle 1450) or a wireless connection. The wire bundle 1450 may run along a ceiling, wall and/or floor of the operating room to communicatively couple with a controller 18. In one embodiment the light fixture 1434 is attached to a mobile support which can be moved about the room or even from one room to another. In one embodiment the system interface 36 is also attached to the light fixture 1434. In one embodiment the controller 18 may be attached to the mobile support of the light fixture 1434 with the antennas 16 directly connected to the controller by 1450.

[0153] The function and operation of the interrogation and detection system 14 in embodiments in which the antennas 1416 are coupled to a light fixture 1434 may be substantially the same as those embodiments in which the antennas 1416 are coupled to the patient support structure 26.

[0154] While FIGS. 14A, 14B, illustrate the antennas 1416 in a particular non-overlapping configuration, the antennas 1416 may be carried by the lampshade 1432 in any suitable configuration. In contrast to the previously described embodiments in which the patient support structure carried the structures, the lightshade 1432 are unlikely to interfere with radiological imaging. Hence, the antennas 1416 may overlap each other, or may be in a non-overlapping configuration. The antennas 1416 may be attached to one or both exterior surfaces of the lightshade 1432. Alternatively the antennas 1416 may be formed within the lightshade 1432, for example, via lamination or weaving. The lightshade 1432 may be made of any material suitable to not interfere with the function of the antennas 1416.

[0155] FIG. 15A shows a drape or curtain 1542 that carries a number of antennas 1516 according to one illustrated embodiment.

[0156] The terms drape and curtain are used interchangeably herein and in the claims. The drape or curtain 1542 may, for example, be used on, over, or in conjunction with a table, bed, frame or other structure during a medical procedure. The drape or curtain 1542 may be coupled to a track 1540 which surrounds a patient support structure 26. The track 1540 is typically in close proximity to the patient support structure and affords a suitable location for the antennas 1516 of the interrogation and detection system 14. In one embodiment, the track may be fastened to a ceiling of a room, for example an operating room, patient room or physician's office or examination room. In such an embodiment, a wire bundle 1550 may also be attached to the ceiling as the wire bundle runs to the system interface 36 or controller 18 situated elsewhere in the surgical environment. The system interface 36 and controller 18 may be attached to a wall of the environment or may be in any other suitable location within the environment in which medical procedures are performed. In another embodiment, the track 1540 may be supported by a freestanding structure or structure fixed or coupled to a floor of the room such as a frame.

[0157] The antennas 1516 may be carried on either exterior surface of the drape or curtain 1542 or be situated (e.g., laminated) within the drape or curtain 1542. While FIG. 15A shows the antennas 1516 on two opposing sides of the patient support structure 26, the antennas 1516 may be positioned on a few or greater number sides of the patient support structure 26 while in use. The drape or curtain 1542 may be selectively deployed and retracted along the track 1540 during use. For example, the drape or curtain 1542 may be retained in a retracted, undeployed position or configu-

ration during times or periods when scanning or interrogation is not being performed. The drape or curtain **1542** may be moved to an extended, deployed position or configuration in preparation for scanning or interrogation, for example, just prior to completing the medical procedures (e.g., surgery) and, for example closing the patient. In other embodiments, the drape or curtain **1542** may be retained in the extended or deployed position or configuration throughout the surgical procedure. The antennas **1516** may be connected to system interface **36** by means of the wire bundle **1550** extending from the curtain **1540**.

[0158] FIG. 15B shows a sheet **1544** carrying a number of antennas **1516** which sheet **1544** may be quickly hung on a rack or frame **1540**. The term sheet is used interchangeably herein and in the claims the terms drape or curtain. The term rack is used herein and in the claims interchangeably with the term frame. The sheet **1544** can be hung from the rack **1540** by connectors **1546**. More than one sheet **1544** may be hung from the rack **1540** on one or more sides of the patient support structure **26**. The antennas **1516** may be attached on either exterior surface of the sheet **1544** or be situated (e.g., laminated or woven) within the sheet **1544**. While the sheet **1544** is illustrated as having four antennas **1516**, there may be as few or as many antennas **1516** on the sheet as desired. Connectors **1546** may include hooks, clamps, or any other fastener suitable to attach the sheet **1544** to the rack **1540**. The antennas **1516** may be connected to the system interface **36** by means of a wire bundle **1550** extending from the sheet **1544**.

[0159] FIG. 16 shows a controller **1618**, according to one illustrated embodiment.

[0160] The controller **1618** may include a housing **1670**. The housing **1670** may contain a motherboard **1672** with a number of ports or connectors **1674a-1674f** (collectively **1674**) to communicatively couple the motherboard **1672** to respective ones of the antennas (e.g., antennas **16**). The motherboard **1672** may also include a number of slot connectors **1676a-1676f** (collectively **1676**) to physically receive respective plug-in boards **1678a-1678f** (collectively **1678**) and communicatively couple the plug-in boards **1678** to the motherboard **1672**. There may, for example be one plug-in board **1678** for each antenna, each of the antennas **16** and plug-in boards **1678** constituting a separate channel. The motherboard **1672** may include additional slot connectors, allowing expansion or use with different antenna configurations or different patient support structures (e.g., surgical tables, patient beds). The plug-in boards **1678** may each carry one or more circuits (e.g., analog and/or digital circuit components) configured to transmit interrogation signals from the respective antenna and to monitor the antenna for responses to the interrogation signals. For example, the plug-in boards **1678** may implement or carry the circuits disclosed in U.S. patent application Ser. No. 11/759,141 filed Jun. 6, 2007, U.S. Provisional Patent Application Ser. No. 61/056,787 filed May 28, 2008, and U.S. Provisional Patent Application Ser. No. 61/091,667 filed Aug. 25, 2008, with or without change, which Patent Applications are incorporated herein by reference in its entirety.

[0161] The motherboard **1672** may also include one or more ports **1679** to receive control signals, for example from the interrogation and detection system interface **36**, **1336** (FIG. 1, FIG. 13A). The motherboard **1672** may also include one or more synchronization circuits **1680** configured to control and synchronize the operation of the various plug-in

boards **1678**. The synchronization circuit **1680** may be configured to cause one of the plug-in boards **1678** to transmit an interrogation signal from a first antenna, and cause one or more of the other plug-in boards to monitor for a response by a transponder to the interrogation signal. For instance, the synchronization circuit **1680** may cause the plug-in boards **1678** to have all of the antennas monitor for a response to the interrogation signal. Alternatively, the synchronization circuit **1680** may cause the plug-in boards **1678** to have all of the antennas other than the antenna that transmitted a most recent interrogation signal monitor for a response. Such may advantageously allow monitoring sooner than would otherwise be possible since such can avoid the need to allow the transmitting antenna to return to a quiescent state after transmitting before monitoring for a response. The synchronization circuit **1680** may synchronize the plug-in boards **1678** to successively cause the various antennas to transmit, for example starting with an antenna at one end, and successively transmitting from each of the antennas in order along the longitudinal axis **30** (FIGS. 1 and 2). Alternatively, the synchronization circuit may synchronize the plug-in boards **1678** to cause the various antennas to transmit, but not in order along the longitudinal axis **30**. As a further alternative, the synchronization circuit **1680** may synchronize the plug-in boards **1678** to cause the transmission of interrogations signals from a subset of the total set of antennas.

[0162] While illustrated as a motherboard **1672** and plug-in boards **1678**, other embodiments are possible. For example, the various antennas may be controlled by respective circuits integrated into a signal circuit board. Alternatively, the various antennas may be controlled by a single circuit.

[0163] FIG. 17 shows a control system **1700** of a controller of an interrogation and detection system, according to one illustrated embodiment.

[0164] The control system **1700** includes a field programmable gate array (FPGA) board **1702**, one or more analog boards **1704**, and a display board **1706**, communicatively coupled to one another. The analog board(s) **1704** may take the form of one or more plug-in boards **1678**, as discussed in reference to FIG. 16. Hence, there may be a respective analog board **1704** for each of the antennas **16** (FIGS. 1 and 2).

[0165] The FPGA board includes an FPGA **1708**, configuration jumpers **1710**, RS-232 drivers **1712**, oscillator **1714**, random access memory (RAM) **1716**, flash memory **1718**, and voltage monitoring (VMON) analog-to-digital converter (ADC) **1720**.

[0166] The FPGA **108** may take the form of a Xilinx Spartan 3 FPGA, which runs FPGA and application software. As explained below, on power up, the FPGA reads the configuration information and application software program from the flash memory **1718**.

[0167] The configuration jumpers **1710** are used to select the application software configuration.

[0168] The RS-232 drivers **1712** are used to allow the application software to communicate using serial RS-232 data for factory test and diagnostics.

[0169] The oscillator **1714** sets the clock frequency for the operation of the FPGA **1708**. The oscillator **1714** may, for example, take the form of 40 MHz oscillator, although other frequencies are possible.

[0170] The RAM 1716 is connected to the FPGA 1708 and is available for use by the application software. The application software uses this memory space for storage of both the executable program and program data. The RAM 1716 may, for example, have a capacity of 1 MB.

[0171] The flash memory 1718 contains both the FPGA configuration data and the binary application program. On power up the FPGA 1708 reads the flash memory to configure the FPGA 1708 and to copy the application program binary data from the flash memory 1718 to the RAM 1702.

[0172] The voltage monitor ADC 1720 is connected to the FPGA 1708 and controlled by the application software to monitor a power supply and regulated voltage forms in controller electronics.

[0173] The analog board 1704 includes transmit control circuits 1722, capacitor selection circuits 1724, an antenna detection circuit 1726, signal ADC 1728, audible beeper 1730 and self-test signal 1732.

[0174] The transmit control circuits 1722 on the analog board 1704 are controlled by signals from the FPGA 1708 to generate a transmit waveform. These signals are denominated as LO\_FET\_ON and HI\_FET\_ON, which control the transmit or drive transistors Q1, Q2 (FIG. 18A) along with a signal denominated as DUMP\_ON which controls a dump TRIAC (FIG. 18A).

[0175] Optional capacitor selection circuits 1724 on the analog board 1704 are controlled by the signals from the FPGA 1708 to tune the drive circuit to match an inductance of the antenna 16 (FIGS. 1 and 2).

[0176] The antenna detection circuit 1726 detects when an antenna 16 (FIGS. 1 and 2) is connected to the controller 20. The output of the antenna detection circuit 1726 drives a signal denominated as the LOOP\_LEVEL\_OUT signal, which is an input to the FPGA 1708.

[0177] The signal ADC 1728 is used to sample the signals received at the antenna 16 from the transponders 24 (FIG. 1). The signal ADC 1728 may, for example, operate at a 1 MHz sample rate and may have 12-bits of resolution. The FPGA board 1702 generates the timing and control signals for the signal ADC 1728, which signal are denominated as ADC\_CTRL, CS1, SCLK, SDO.

[0178] The aural indicator (e.g., speaker or beeper) 42 (FIGS. 1 and 2) can be controlled by the FPGA 1708 to emit sounds to indicate various states, modes or operating conditions to the medical provider.

[0179] The FPGA 1708 can cause the generation of the self test signal 1732 on the analog board 1704 at the signal ADC 1728. Self-testing may be performed at start up, and/or at other times, for example periodically or in response to the occurrence of certain conditions or exceptions.

[0180] The display board 1706 includes user interface elements, for example a number of visual indicators (e.g., LEDs, LCDs, etc.) 40 (FIGS. 1 and 2). The FPGA board 1702 can control the visual indicators 40 on the display board 1706. The display board 1706 also includes a user selectable activation switch 44, denominated as front panel button 1736. The front panel button 1736 is connected to the display board 1706 which allow the FPGA 1708 to monitor when the front panel button 1736 is activated (e.g., pressed).

[0181] FIG. 18 shows a software configuration 1800 of the interrogation and detection system 14, according to one illustrated embodiment.

[0182] The software may include application software 1802 that is responsible for operating the controller 18

(FIGS. 1 and 2). The application software 1802 controls the timing for generating transmit pulses, processes sampled data to detect transponders 24 (FIGS. 1 and 2), and indicates status to the user with the visual indicators 40 (FIGS. 1 and 2) on the display board 1706 (FIG. 17) and/or via the aural indicator 42 on the analog board 1704 (FIG. 17). The application software 1802 is stored in the flash memory 1718 (FIG. 17) and transferred into the RAM 1716 by a boot loader 1804.

[0183] The boot loader 1904 is automatically loaded when the FPGA 1708 is configured, and starts execution after a processor core 1806 is reset. The boot loader 1804 is responsible for transferring the application software 1802 from the flash memory 1718 to the external RAM 1716.

[0184] The processor platform 1808 is configured into the FPGA 1708 (FIG. 17) on power up from the configuration information stored in the flash memory 1718. The processor platform 1808 implements a custom microprocessor with a processor core 1806, peripherals 1810a-1810n, and custom logic 1812.

[0185] The processor core 1806 may take the form of a soft processor core supplied by XILINX under the name MICROBLAZE™, that implements a 32-bit processor including memory caches and a floating point unit. A soft core processor is one that is implemented by interconnected FPGA logic cells instead of by a traditional processor logic. The processor core 1806 is connected to the internal FPGA peripherals 1810a-1810n using a 32-bit processor bus 1811 called the On-Chip Peripheral Bus. The XILINX supplied peripherals for the MICROBLAZE™ processor core 1806 include external memory interfaces, timers, and general purpose I/O.

[0186] The custom logic 1812 to create the transmit signals, sample the ADC, and accumulate the transponder return signals is designed as a peripheral to the processor core 1806. The custom logic 1812 is the part of the design of the FPGA 1708.

[0187] Some embodiments may substitute a full microprocessor for the soft processor core. Thus, for example, a microprocessor such as the ATOM™ processor, commercially available from Intel Corporation, may be employed in place of the MICROBLAZE™ processor core. The full microprocessor may be communicatively coupled to multiple analog antenna channels via one or more FPGAs and one or more suitable buses. The FPGA may, for example, act as a co-processor and/or cache. Additionally, or alternatively, a higher bandwidth bus architecture may be employed. For example, a PCI express™ or PCIe™ bus architecture may be employed, rather than an ISA bus architecture. Suitable FPGAs may include those from ATMEL Corporation. Such FPGAs may advantageously have built in PCIe bus architecture, allowing easy integration. This approach may enable more I/O ports, such as USB ports, may provide more or better video options, and may provide faster data rates from the analog antenna channels that otherwise possible using the ISA bus architecture and soft processor core approach.

[0188] FIGS. 19A-19I show a control circuit 1900 according to one illustrated embodiment. The control circuit 1900 is used to drive the antenna 16 (FIGS. 1 and 2) to excite or interrogate transponders 24 (FIGS. 1 and 2), and to detect and process signals received by the antenna 16 from the transponders 24. As previously noted, there may be a

respective control circuit **1900** for each of the antennas **16**, or a single control circuit may be configured to control multiple antennas.

[0189] The control circuit **1900** includes a transmitter circuit **1902** formed by a pair of drive transistors (e.g., field effect transistors) **Q1**, **Q2** operated in a push-pull configuration between a high voltage rail (e.g., 24 V) and a low voltage rail (e.g., GND). The drive transistors **Q1**, **Q2** are responsive to respective drive signals **DRIVE\_HI**, **DRIVE\_LO**, which are applied to the gates of the respective drive transistors **Q1**, **Q2**. The drive transistors **Q1**, **Q2** are coupled to the antenna **16** by a non-switched capacitor **C8** and the coaxial cable **20**. The antenna **16** and capacitor **C8**, as well as capacitance provided by the coaxial cable **20**, form an LC circuit.

[0190] Optionally, the control circuit **1900** may also include a dynamic tuning circuit **1904**. The dynamic tuning circuit **1904** selectively adjusts the capacitance of the LC circuit. In the illustrated embodiment, the dynamic tuning circuit **1904** includes a number of switched capacitors **C33-C36** and relays **U9**, **U10**. The relays **U9**, **U10** are operated to selectively couple the switched capacitors **C33-C36** in series with the non-switched capacitor **C8**, thereby adjusting the LC characteristics of the LC circuit, and allowing fine tuning of the LC circuit around center frequencies or center channels of a number of wide band frequency bands, as described in more detail below.

[0191] FIG. **20** illustrates a detection cycle **2000** that employs an approach that optimizes signal to noise ratio (SNR), according to one illustrated embodiment. Such may, for example, advantageously increase range or increase sensitivity at a given range.

[0192] One embodiment is optimized based on having an overall detection cycle that performs well for transponders with resonant frequencies from approximately 136 KHz to approximately 154 KHz, and which has a pulse timing that is consistent with hardware limitations. An optimal SNR may be achieved by, for example, transmitting a single wideband frequency pulse.

[0193] The application software **1802** (FIG. **18**) implements the detection cycle **2000** using transmission or interrogation in a frequency band centered around a center channel or frequency. In the illustrated embodiment, the application software **1802** sequences through a non-measurement portion (i.e., gap) **2000a**, and two distinct measurement portions, denominated as a noise detection portion **2000b** and an interrogation or signal detection portion **2000c**, each detection cycle **2000**. In at least one embodiment, the detection cycle **2000** may, for example, be approximately 275 milliseconds, the gap portion may be approximately 10 milliseconds, the noise portion approximately 37 milliseconds and the interrogation or signal portion approximately 228 milliseconds.

[0194] During the noise detection portion **2000b**, which may, for example be a first measurement portion of each detection cycle **2000**, ambient or background noise is measured or sampled, providing a value indicative of a level of ambient or background noise for the particular environment. The noise measurements or samples are taken or captured at a time sufficiently after excitement of the transponders **24** (FIG. **1**) by the interrogation signal emitted by the transmitter such that the transponders **24** are substantially not resonating or responding to any previous excitation by

interrogation signals. In particular, a number **N** of measurements or samples are taken during the noise detection or first measurement portion **2000b**.

[0195] During the interrogation portion **2000c**, which may, for example take the form of the second measurement portion of each detection cycle **2000**, responses by transponders **24** are measured or sampled. The response measurements or samples are taken with the transmitter transmitting or at a time sufficiently close to excitement of the transponders **24** by the interrogation signal emitted by the transmitter such that the transponders **24** are still substantially resonating or responding to the interrogation signal. In particular, a number **M** of measurements or samples are taken during the interrogation or second measurement portion **2000c**.

[0196] While the interrogation portion **2000c** is illustrated as one contiguous or continuous portion **2000c**, in some embodiments the interrogation portion **2000c** may take the form of two or more separate portions or intervals. Each of the portions **2000c** may employ the same transmit frequency band, for example centered around 145 KHz. Other center channels or frequencies may for example be 136 KHz, 139 KHz, 142 KHz, 145 KHz, 148 KHz, 151 KHz and/or 154 KHz, or any other frequency suitable for exciting the transponder to resonate. Some embodiments may employ frequency hopping, for example transmitting a different center channel or frequency for each of a plurality of interrogation portions **2000c** of each detection cycle **2000**. Such is discussed further in U.S. provisional patent application Ser. No. 60/892,208, filed Feb. 28, 2007 and U.S. non-provisional application Ser. No. 11/743,104, filed May 1, 2007.

[0197] The gap portion **2000a** may provide time for the response of the transponders **24** to the interrogation signal to decay sufficiently to allow measurement of noise.

[0198] Some embodiments may arrange the gap **2000a**, the noise detection portion **2000b** and/or the interrogation portion **2000c**, or parts thereof, in a different order.

[0199] In one embodiment, the time to accumulate the noise sample or value indicative of a noise level may, for example, be approximately 37 milliseconds, and the time to accumulate the transponder signal measurement approximately 228 milliseconds. Along with a gap **2000a** of approximately 10 milliseconds between the signal and noise portions, the time for a single detection cycle **2000** would be approximately 275 milliseconds. As noted above, the transmitter is OFF during the noise measurement portion **2010b** of each detection cycle to measure ambient noise, and the signal measurement portion **2010c** is taken with the transmitter transmitting a wideband interrogation signal about the particular center channel or frequency.

[0200] The noise samples may be accumulated and a highest one or more of multiple samples or measurements over one or more detection cycles selected or used to prevent unwarranted fluctuations. The response signals from the transponder **26** may be accumulated and/or averaged or integrated over one detection cycle or over multiple detection cycles.

[0201] The number **N** of noise measurements or samples and/or the number **M** of response measurements or samples may be selected to achieve a desired ratio of **N** to **M**, in order to achieve or maintain a desired signal to noise ratio. For example, obtaining 200 noise measurements or samples and 800 response measurements or samples each detection cycle results in an SNR of approximately 2 (e.g., the square root of the 800 divided by 200). While an SNR as low as 1.1:1

may be sufficient in some embodiments, an SNR approaching 2:1 ensures sufficient differentiation to eliminate or reduce the possibility of false positives to an acceptable level for the particular applications envisioned herein. Any known hardware and software accumulators, summer, integrators and/or other hardware or software may be suitable.

[0202] FIG. 21A illustrates pulse timing, according to one illustrated embodiment.

[0203] The custom logic in the FPGA 1708 (FIG. 17) generates the timing and control signals for each pulse 2110. During a transmit portion 2110a of the pulse 2110, the logic of the FPGA 1708 drives the drive transistor control lines to generate the transmit signal. The FPGA logic controls the frequency of the transmit signal. During a dump portion 2110b of the pulse 2110, the logic of the FPGA 1708 drives the gate of the dump TRIAC T1 to quickly drain the transmit energy from the antenna 21 in order to allow detection of the response signal from the transponder 24, if any. A recovery portion 2110c of the pulse 2110 allows receiver filters and amplifiers to recover from the transmitted pulse before detecting the response signal from the transponder 24, if any. During the receive response portion 2110d of the pulse 2110, the FPGA 1708 controls the signal ADC 1728 to sample the response signal from the transponder 24, if any. The signal ADC 1728 may, for example, sample at a 1 MHz sample rate with a 12-bit resolution. A dither portion 2110e of the pulse 2110 has a random variable length of time, and may, for example be generated by a pseudo-noise (PN) sequence generator. Adding a random length of time between pulses de-correlates the response signal received from the transponder 24 from constant frequency sources of interference, if any.

[0204] For example, within each of 228 millisecond signal measurement intervals 400c discussed above, the custom logic of the FPGA 1708 (FIG. 17) accumulates the received signals from, for example 800 pulses.

[0205] FIG. 21B illustrates pulse timing, according to one illustrated embodiment. The pulse timing is similar in some respects to that illustrated in FIG. 21A, hence similar or identical structures, acts or features are identified using the same reference numbers. Only significant differences between the two are discussed below.

[0206] In contrast to the embodiment of FIG. 21A, the embodiment of FIG. 21B may advantageously eliminate the dump portion 2110b of the pulse 2110. Such may be omitted, for example, where the antenna 21 that transmitted the most recent interrogation signal is not being used to monitor for a response to the interrogation signal. Such may advantageously allow monitoring for the response to occur sooner than would otherwise be possible if the dump portion 2110b were needed.

[0207] Also in contrast to the embodiment of FIG. 21A, the embodiment of FIG. 21B may advantageously eliminate the recovery portion 2110c of the pulse 2110. Such may be omitted, for example, where the antenna 16 that transmitted the most recent interrogation signal is not being used to monitor for a response to the interrogation signal. Such may advantageously allow monitoring for the response to occur sooner than would otherwise be possible if the recovery portion 2110c were needed.

[0208] Removal of the dump portion 2110b and/or recovery portion 2110c may allow for a more favorable sampling rate or better resolution or may allow a longer noise detection portion, which may significantly enhance performance.

[0209] FIG. 22 shows signal timing for driving the drive transistors Q1, Q2 (FIG. 19A), according to one illustrated embodiment.

[0210] The custom logic in the FPGA 1708 (FIG. 17) generates the signals 2220a, 2220b to drive the drive transistors Q1, Q2 (FIG. 19A) during the transmit portion 2110a (FIG. 21) of the pulse 2110. A transmit (TX) period value is used by the logic of the FPGA 1708 to set the transmit frequency. The low transistor (e.g., Low FET) Q2 turns ON at the beginning of the transmit period. The Low FET off value controls when the low transistor (e.g., Low FET) Q2 is turned OFF. The low transistor Q2 is turned OFF before the high transistor (e.g., High FET) Q1 is turned ON to avoid a short circuit through the transistors Q1, Q2. The High FET on value controls when the high transistor (e.g., High FET) Q1 is turned ON. The High FET Off value controls when the high transistor Q1 is turned OFF. The high transistor is turned OFF before the low transistor Q2 is turned ON to avoid a short circuit through the transistors Q1, Q2. For example, to achieve a transmit frequency of 144.9 KHz, the transmit period should be set to 6.9  $\mu$ sec. Also for example, a suitable duration that both the low and high transistors Q1, Q2 are OFF may be set to 400 nsec.

[0211] The ADC converts the signal received from the transponder 24, if any, from analog to digital. Such conversion may, for example, be performed at a sampling rate of 1 MHz with a 12-bit data resolution. The sampled ADC data is then accumulated together or integrated, for example over 800 measurements or samples, to compute the total summed response signal received from the transponder 24, if any.

[0212] The accumulated or integrated received signal may be match filtered with both in-phase and quadrature reference signals to determine the signal magnitude. The received receive signal is matched filtered with a plurality of reference signals, for example with the seven reference signals, for instance as shown in Table 1 below. Some embodiments, may employ match filtering before accumulating or integrating the received signal.

TABLE 1

Match Frequency
136 KHz
139 KHz
142 KHz
145 KHz
148 KHz
151 KHz
154 KHz

[0213] The maximum value for the matched filters (e.g., seven matched filters) with active transmit is compared with an adjusted detection threshold. If the maximum value is greater than the detection threshold, then a response signal from a transponder 26 is considered as having been detected, and appropriate action is taken.

[0214] Noise faults may be detected as well as antenna transmit voltage faults. Noise faults may be detected when the matched filter output during the noise detection portion is greater than a noise fault threshold (e.g., a threshold magnitude 2.7 mV over a threshold time, e.g., 7 seconds or threshold magnitude 7 mV over a time threshold of 7 seconds). Antenna transmit voltage faults may be detected when the antenna transmit voltage drops below an antenna voltage fault threshold (e.g., 270 V<sub>Peak-to-Peak</sub>). Two envi-

ronmental faults in a row such as the above, may trigger an Environmental Error Mode, while two normal measurements in a row may return to a normal Scan Mode. Faults in general are discussed in more detail below. Alternatively, the interrogation and detection system may employ a fast Fourier transform approach in lieu of match filtering.

[0215] FIG. 23A shows a method 2300 of operating the interrogation and detection system 14, according to one illustrated embodiment.

[0216] The method 2300 starts at 2302. For example, the method 2300 may start on application of power to the interrogation and detection system 12 or in response to activation of a switch by a user such as a clinician, surgeon

[0217] In response to detecting an application of power, the interrogation and detection system 14 may enter a Power-Up mode. The Power UP mode 502 may, for example, in response to the application of power to the controller 18 and turning ON the switch on the controller 18. In the Power-Up mode, a Power indicator (e.g., LED) may be turned ON or illuminated, and may remain ON or illuminated as long as the power is applied and the switch is in the ON state. In response to entering the Power UP mode, the software 1800 may perform software initialization, built in tests, and an audio/visual test. If a fault is detected, the software 1800 may progress to a System Fault Mode. If no faults are detected, the software 1800 may turn a System Ready indicator (e.g., LED green), and enter an antenna Detection Mode. In the System Fault mode, the software 1800 may cause an indication of the detection of a system fault by blinking a System Ready indicator (e.g., LED) yellow, and/or issuing a sequence of rapid beeps or other sounds. The corrective action for the System Fault Mode may be to cycle power to reinitiate the Power Up mode. Continued failure indicates a failed controller 18.

[0218] In the Antenna Detection Mode, the software 1800 checks for antennas 16 connected to the controller 18. The Antenna Detection Mode may be indicated by turning the System Ready indicator (e.g., LED) green and turning the Antenna Ready indicator (e.g., LED) OFF. If no antenna 16 is detected, the software 1800 remains in the Antenna Detection Mode. If one or more antennas 16 are detected, the software 1800 makes note of the total number of antennas and progresses to the Antenna Initialization Mode.

[0219] At the start of the Antenna Initialization Mode, after the detection of the antennas 16, the software 1800 may turn the Antenna Ready indicator (e.g., LED) yellow and optionally check for the presence of a respective fuse coupled to antennas 16. If a fuse is found, the software 1800 may attempt to blow the fuse and verify that the fuse was correctly blown. After the fuse is blown the software 1800 may verify that respective antenna 16 is operating within tolerances. The software 1800 may indicate that the antenna 16 is ready by turning the Antenna Ready indicator green. The software 1800 may also start a timer which will allow the antenna 16 to be disconnected and reconnected to the controller for a period of time (e.g., 5 hours) after the fuse is blown. The controller 18 may determine the adjustments or fine tuning to be made about the center frequencies or channels during Antenna Initialization Mode. In particular, the controller 18 may determine the particular frequency in each of the frequency bands that elicits the response with the highest voltage. The controller 18 may determine such by varying the capacitance of the LC circuit using the switched capacitors C33-C36 during the Antenna Initialization Mode.

The particular combination of switched capacitors C33-C36 which achieved the response with the highest voltage may then be automatically employed during the Scan Mode (discussed below) to adjust or fine tune about the center frequency or channel in each broad band of transmission. Other approaches to determining the fine tuning may be employed.

[0220] If the software 1800 does not successfully complete the Antenna Initialization Mode, the software 1800 enters an Invalid Antenna Mode. If the software 1800 successfully completes the Antenna Initialization Mode, the software 1800 progresses to the Scan Mode to automatically start scanning. In the Invalid Antenna Mode, the software 1800 may blink the Antenna Ready indicator yellow and issues a slow beep pattern. The Invalid Antenna Mode may be entered in response to any of the following conditions: 1) the antenna 16 connected to the controller 18 is out of tolerance; 2) the controller 18 is unable to blow the fuse of the antenna 16; 3) the antenna 16 does not have a fuse and more than the set time period has past (e.g., 5 hours) since a fuse was blown; 4) the antenna 16 does not have a fuse and the controller 18 has been restarted; 5) the antenna 16 has been connected to the controller 18 for more than the set time period (e.g., 5 hours); 6) the antenna 16 is detuned due to close proximity to metal. The corrective action for the Invalid Antenna Mode is to remove the invalid antenna 16 and attach a new antenna 16 to the controller 18 that contains a fuse or to reconnect the antenna 16 while holding it in the air at least 2 feet away from large metallic objects. The software 1800 enters the Scan Mode when the antennas 16 are ready and the operator presses a Start/Stop button. The software 1800 may issue a short three beep pattern via the speaker or beeper when entering the Scan Mode to identify the entry to the user.

[0221] In the Scan Mode, the software 1800 may continuously or periodically perform the following functions: 1) look for response signals from transponders 24; 2) monitor the noise level; 3) insure the antennas 16 are connected and operating correctly; and 4) blink the appropriate indicator in a circular pattern. The interrogation and monitoring for response may be performed using a detection cycle, such as that set out in FIGS. 21A, 21B and the description related to those Figures. While, not specifically set out in FIG. 18, such may also include optimization of signal to noise ratio, such as set out in FIG. 20 and the description related thereto.

[0222] At 2304, a timer starts. The timer allows a limit to be set on the amount of time spent scanning for a transponder 24 (i.e., scan maximum time interval). Alternatively, a counter could be employed to set a limit of the number of iterations that the antennas 16 are successively employed to transmit interrogation signals.

[0223] At 2306, an antenna counter  $i$  is set, for example set to 1. The antenna counter allows the method 2300 to successively iterate through each of a number  $N$  of antennas 16 to transmit the interrogation signal. The number  $N$  of antennas 16 may have been determined during the Antenna Detection Mode.

[0224] At 2308, an interrogation signal is transmitted from an  $i^{\text{th}}$  antenna 16. In particular, the FPGA 1708 (FIG. 17) may cause one of the plug-in boards to cause the antenna 16 coupled thereto to transmit an interrogation signal. The interrogation signal may advantageously take the form of an unmodulated interrogation signal, for example in the radio or microwave portions of the electromagnetic spectrum.

[0225] At 2310, one or more antennas 16 are monitored for a response to the interrogation signal. In particular, a number of the plug-in boards may monitor the respective antenna coupled thereto for the response to the interrogation signal. For example, all of the antennas 16 may be monitored to a response to the interrogation signal. Alternatively, all except the antenna 16 that transmitted the most recent interrogation signal (i.e.,  $i^{th}$  antenna) may be monitored for a response to the interrogation signal. As another alternative, some subset of all of the antennas 16 may be monitored for a response to the interrogation signal. The response may advantageously take the form of an unmodulated response signal, for example in the radio or microwave portions of the electromagnetic spectrum.

[0226] At 2312, it is determined if a response to the interrogation signal was received. For example, the FPGA 1708 (FIG. 17) may poll or otherwise monitor each of a number of plug-in or analog boards to determine if a response signal was detected via any of the antennas coupled to those plug-in or analog boards. If a response to the interrogation signal was received, a suitable indication is provided at 2314, and the method 2300 terminates at 2316. For example, when an appropriate response signal from a transponder 24 is detected while in Scan Mode, the software 1800 may turn ON an amber DETECT indicator (e.g., LEDs) and/or provide an audible alarm. The alarm may, for example, beep a continuous solid tone as long as the transponder is detected, with a minimum of beep duration of, for instance 0.5 second. If a response to the interrogation signal was not received, it is determined whether there are additional antennas to transmit the interrogation signal from at 2318.

[0227] If there are additional antennas to transmit from, the counter is incremented at 2320 and control returns to 2308 to transmit via the next  $i+1^{th}$  antenna 16. This can allow iteration through a number of antennas 16 as the antenna that transmits the interrogation signal. As previously explained, antennas 16 may be operated to transmit an interrogation signal in an order of appearance along a longitudinal axis of the patient support surface or may be operated in any other order. Also as previously noted, all or some lesser number of antennas may be employed to transmit the interrogation signal in any single pass or iteration through the set or subset of antennas 16.

[0228] If there are not further antennas to transmit the interrogation signal from, it is determined if a time limit (i.e., scan maximum time interval) has been exceeded at 2322. If the time limit has been exceeded the method 2300 terminates at 2316. If the time limit has not been exceeded, the counter is reset at 2306. This allows multiple passes through the use of each antenna in a set or subset of antennas 16 as the interrogating antenna 16. When the operator or user pushes the Start/Stop button or the a scan maximum time interval (e.g., 4 minute) has been reached, the software 1800 may issue a short three beep pattern and return to the Antenna Ready Mode.

[0229] If the software 1800 detects that one of the antennas 16 is disconnected while in the Scan Mode, the software 1800 enters the Scan Fault Mode. In the Scan Fault Mode, the software 1800 may issue a sequence of rapid beeps and blink ON and OFF the amber DETECT indicator. The Scan Fault Mode can be cleared by pushing the Start/Stop button. The software 1800 will automatically clear the scan fault mode after 10 beeps.

[0230] While in the Scan Mode, if excess noise or loss of transmit signal is detected, the software 1800 may progress to the Environment Error Mode. In the Environment Error Mode, the software 1800 may issue or produce an appropriate indication. For example, the software 1800 may cause the production of a sequence of slow beeps and the blinking ON and OFF the green circle indicator. The corrective action for the Environment Error Mode is to reposition the antenna with respect to any large metal objects or sources of electrical interference. The software 1800 may automatically stop the scan if the environment error condition lasts for more than a set time or number of beeps (e.g., 5 beeps).

[0231] FIG. 23B shows a method 2310*b* of monitoring all antennas for a response to an interrogation signal, according to one illustrated embodiment.

[0232] At 2318, an interrogation and detection system monitors all antennas 16 for a response to the interrogation signal.

[0233] FIG. 23C shows a method 2310*c* of monitoring all antennas except a transmitting antenna for a response to an interrogation signal, according to one illustrated embodiment.

[0234] At 2320, an interrogation and detection system monitors all antennas 16 for a response to the interrogation signal, except the antenna 16 the transmitted the most recent interrogation signal.

[0235] FIG. 24A shows a method of operating an interrogation and detection system to detect transponders 2400*a*, according to one illustrated embodiment.

[0236] The method 2400*a* starts at 2401. For example, the method 2400*a* may start when the interrogation of detection system is turned ON, or when power is supplied, or in response to a call from a procedure or function.

[0237] At 2402, an antenna counter I is set, allowing the method 2400*a* to iterate through one or more antennas (n) of the interrogation and detection system. The interrogation and detection system iterates through the antennas by transmitting interrogations signals successively from each of a number of the antennas, typically one antenna at a time, and monitoring or listening for response signals on one or more of the antennas.

[0238] At 2403, the interrogation and detection system measures averaged noise and averaged signals. At 2404, the interrogation and detection system processes the averaged noise and averaged signal, and at 2405 determines whether a transponder (i.e., return or response signal from transponder) has been detected.

[0239] In the embodiment illustrated in FIG. 24A, the interrogation and detection system requires more than one (e.g., two) successive detections of the transponder to conclude that the signal detected indicates the presence of a transponder. Such prevents against false positive determinations. Hence, at 2406, the interrogation and detection system again measures averaged noise and averaged signals. At 2407, the interrogation and detection system again processes the averaged noise and averaged signal and at 2408 determines whether a transponder (i.e., return or response signal from transponder) has been detected.

[0240] If a transponder has been detected an adequate number of times (e.g., twice), the interrogation and detection system provides notification at 2409. Notification may, for example, include sending an electrical or optical signal and/or producing a visual, aural or tactile alert to a user (e.g., medical service provider). If the interrogation and detection

system determines that a transponder has not been detected at either **2405**, **2407**, control passes to **2410**.

[0241] At **2410**, the interrogation and detection system determines whether there are further antennas to iterate through. If so, the antenna counter is iterated, and control returns to **2403**. If not, the method **2400a**, may terminate at **2412**. Alternatively, the method **2400a** may return to **2402** and continuously repeat as long as power is supplied to the interrogation and detection system.

[0242] FIG. **24B** shows a method of operating an interrogation and detection system to sample noise and responses and to adjust sampling times and perform noise correction **2400b**, according to one illustrated embodiment, the method useful with the method of FIG. **24A**.

[0243] The method **2400b** starts at **2420**. For example, the method **2400b** may start in response to a call from a procedure that implements the method **2400a**. The method **2400b** may, for example, be employed in measuring averaged noise and averaged signal **2403** (FIG. **24A**).

[0244] At **2421** a transmitter of the interrogation and detection system is OFF (i.e., not transmitting interrogation signals) or is turned OFF if not already OFF. This starts a noise detection portion of a transponder detection cycle. At **2422** ambient noise received by the antennas is sampled. For example, ambient noise detected by all of the antennas may be sampled by the interrogation and detection system.

[0245] At **2423**, the interrogation and detection system determines noise cancellation factors for each antenna. The interrogation and detection system may employ a variety of approaches for determining the noise cancellation factors, for example computing a noise cancellation factor for each antenna based on ambient noise detected on all of the other antennas except the antenna for which the respective noise cancellation factor is being computed.

[0246] At **2424**, the interrogation and detection system determines a sample averaging time for sampling noise based on the measured ambient noise level. At **2425**, the interrogation and detection system determines a sample response averaging time based on the measured ambient noise level. The sample averaging times determine how long samples of noise or response will be averaged in determining noise or response measurements or levels. Such dynamic determination of sample averaging times allows the interrogation and detection system to accommodate a changing noise environment. For example when a piece of equipment is introduced or removed from the environment or a piece of equipment turns ON or OFF, or otherwise changes amount or frequency distribution of noise it generates in the environment. Thus, the interrogation and detection system may obtain adjust the noise floor to increase range in real time or almost real time in response to the actual noise in the environment.

[0247] At **2426**, the interrogation and detection system averages noise corrected noise samples for the noise sample averaging time. As noted above, the noise sample averaging time may be determined dynamically. The noise samples may be corrected, for example, using the determined noise cancellation factors.

[0248] At **2427**, the interrogation and detection system transmits interrogation signal(s) from one of the antennas. As previously noted, the interrogation and detection system may iterate through the antennas one at a time, for example using an antenna counter *I*. At **2428**, the interrogation and detection system averages noise corrected responses for the

response averaging time. As noted above, the response sample averaging time may be determined dynamically. The response samples may be corrected, for example, using the determined noise cancellation factors. It is noted that as received, the response signals typically contain a mix of signal and noise, hence is generally referred to herein as responses. After noise correction, the result is theoretically pure signal. In practice there may be some still be some amount of noise remaining, however the signal will typically dominate the noise after noise correction.

[0249] The method **2400b** may terminate at **2429**, for example until called again by the procedure that implements **2400a** (FIG. **24A**) to transmit interrogation signals from a next antenna.

[0250] FIG. **24C** shows a method of operating an interrogation and detection system to determine whether a transponder has been detected **2400c**, according to one illustrated embodiment, the method useful with the method of FIG. **24A**.

[0251] The method **2400c** starts at **2440**. For example the method **2400c** may start in response to a call from a procedure that implement the method **2400a** (FIG. **24A**). The method **2400c** may, for example, be employed in processing transponder detection **2404** (FIG. **24A**).

[0252] FIGS. **25A-25E** are flow diagrams of methods of operating an interrogation and detection system by measuring and/or compensating for noise, according to various illustrated embodiments, the methods useful with the method of FIG. **24A**.

[0253] At **2441**, the interrogation and detection system transforms the averaged noise and response samples from a time domain to a frequency domain. The interrogation and detection system may, for example, perform fast Fourier transforms on the averaged samples. At **2442**, the interrogation and detection system may find a peak of response fast Fourier transformed spectrum data.

[0254] At **2443**, the interrogation and detection system determines an amplitude threshold based on the averaged noise level. At **2444**, the interrogation and detection system determines whether the response amplitude is equal or exceeds the determined amplitude threshold. If so, control passes to **2445**. If not, control passes to **2448** where a signal may optionally be produced indicative of no tag being detected.

[0255] At **2445**, the interrogation and detection system determines whether the signal is in appropriate frequency range. While the frequency range is illustrated as being between 137 KHz and 165 KHz, inclusive, other frequency ranges may be employed depending on the specific structure and frequency of the transponders. The disclosed embodiments are particular suited for use with low Q transponders in which the response frequencies of various transponders are not closely controlled, advantageously allowing large manufacturing tolerances to reduce cost. If the signal is in the appropriate frequency range, control passes to **2446**, otherwise control goes to **2448**.

[0256] At **2446**, the interrogation and detection system determines the Q value of the response. For example, the interrogation and detection system may compute the slope of the received signal decay at a number of windows (e.g., 5 windows). At **2450**, the interrogation and detection system determines if the determined Q value is greater than or equal to a threshold Q value (e.g., 35). While the threshold Q value is illustrated as being 35, other Q values may be employed

depending on the Q value(s) of the specific transponders. If the tag response Q value below the Q value threshold, the interrogation and detection system determines that a transponder has been detected at **2450**. If the tag response Q value is equal or above the Q value threshold, the interrogation and detection system determines that a tag has not been detected **2448**.

[0257] The method **2400c** may terminate at **2449**, for example until called again by the procedure that implements the method **2400a** (FIG. 24A).

[0258] FIG. 25A shows a method **2500a** of measuring or sampling responses, according to one illustrated embodiment.

[0259] In particular, at **2510**, the interrogation and detection system measures or samples response on all antennas or antenna channels.

[0260] FIG. 25B shows a method **2500b** of determining noise estimates, according to one illustrated embodiment.

[0261] In particular, at **2520**, the interrogation and detection system determines noise estimates based on measures or samples from all antennas or antenna channels other than the respective antenna or antenna channel for which the noise estimate will provide the compensation factors.

[0262] FIG. 25C shows a method **2500c** of determining noise estimates, according to one illustrated embodiment.

[0263] In particular, at **2530**, the interrogation and detection system determines an average noise estimate based on averaging of measures or samples from all antennas or antenna channels other than the respective antenna or antenna channel for which the noise estimate will provide the compensation factors.

[0264] FIG. 25D shows a method **2500d** of determining noise estimates, according to one illustrated embodiment.

[0265] In particular, at **2540**, the interrogation and detection system determines an average noise estimate based on averaging of measures or samples from all antennas or antenna channels other than the respective antenna or antenna channel for which the noise estimate will provide the compensation factors. The averaging includes averaging of noise detection portions which occur both before and after an interrogation portion of a transponder detection cycle. Such allows the interrogation and detection system to essentially determine whether the noise is consistent, periodic, or non-random.

[0266] FIG. 25E shows a method **2500e** of determining noise estimates, according to one illustrated embodiment.

[0267] In particular, at **2550**, the interrogation and detection system determines an average noise estimate by determining a decomposed least squares average of noise measurements or samples. While a decomposed least squares approach is illustrated, a wide variety of other approaches may be employed (e.g., Bayesian averaging).

[0268] FIG. 25F shows a method **2500f** of determining noise estimates, according to one illustrated embodiment.

[0269] In particular, at **2560**, the interrogation and detection system compares noise measured from before an interrogation portion of the transponder detection to noise measured after the interrogation portion of the transponder detection cycle. A difference between the noise measurements may represent variation in noise. At **2562**, the interrogation and detection system may increase the sample averaging time for sampling responses to interrogation signals if a determined difference (i.e., variation in noise) is greater than a variation threshold. Such may allow the

interrogation and detection system to accommodate different noise sources, such as those that produce periodic or non-random versus those that produce random noise.

[0270] FIG. 26A shows a measured or sampled response **2600a**, according to one illustrated embodiment.

[0271] The response **2600a** in the time domain was measured in an environment which contained a noise source (e.g., fluoroscope) but no transponder. The response **2600a** has not been subjected to noise cancellation or adjustment. The amplitude (Y-axis) is in mV, while the time (X-axis) is in ps.

[0272] FIG. 26B shows a measured or sampled response **2600b**, according to one illustrated embodiment.

[0273] The response **2600b** is the response **2600a** having been subjected to noise cancellation or adjustment. Most of the peaks have noticeably been diminished.

[0274] FIG. 26C shows a measured or sampled response **2600c**, according to one illustrated embodiment.

[0275] The response **2600c** is the response **2600a** after a fast Fourier transformation to the frequency domain. The amplitude (Y-axis) is in mV, while the time (X-axis) is in frequency. There are three distinctive peaks of noise.

[0276] FIG. 26D shows a measured or sampled response **2600d**, according to one illustrated embodiment.

[0277] The response **2600d** is the noise cancelled response **2600b** after a fast Fourier transformation to the frequency domain. The peaks have been noticeable diminished, indicating that almost all noise has been removed by the noise cancellation.

[0278] FIG. 27A shows a sampled or measured response **2700a**, according to one illustrated embodiment.

[0279] The response **2700a** in the time domain was measured in an environment which contained a noise source (e.g., fluoroscope) and a transponder. The response **2700a** has not been subjected to noise cancellation or adjustment. The amplitude (Y-axis) is in mV, while the time (X-axis) is in ps.

[0280] FIG. 27B shows a measured or sampled response **2700b**, according to one illustrated embodiment.

[0281] The response **2700b** is the response **2700a** after being subjected to noise cancellation. While many the peaks (associated with noise) have noticeably been diminished, other distinctive peaks remain.

[0282] FIG. 27C shows a measured or sampled response **2700c**, according to one illustrated embodiment.

[0283] The response **2700c** is the response **2700a** after a fast Fourier transformation to the frequency domain. The amplitude (Y-axis) is in mV, while the time (X-axis) is in frequency. There are three distinctive peaks.

[0284] FIG. 27D shows a measured or sampled response **2700d**, according to one illustrated embodiment.

[0285] The response **2700d** is the noise cancelled response **2700b** after a fast Fourier transformation to the frequency domain. Two of the three peaks have been noticeable diminished, indicating that almost all noise has been removed by the noise cancellation, and leaving a single distinctive peak at the resonant frequency of the transponder.

[0286] The above described embodiments may improve a detection range versus noise performance over other more conventional approaches. The embodiment of the present disclosure may be capable of achieving far superior performance, having greater detection range in even mildly noisy environments. Such is particularly advantageous in environments such as operating theaters, and substantially helps

reduce false readings (e.g., false positives, false negatives). Thus, such may provide the level of performance demanded by hospitals and doctors.

**[0287]** Thus, during each of a plurality of detection cycles, the interrogation and detection system performs a number of acts or operations. The interrogation and detection system receives unmodulated electromagnetic signals during a noise detection portion of the detection cycle.

**[0288]** The interrogation and detection system determines a noise value indicative of a noise level that corresponds to a highest one of a number N of samples or measurements of the unmodulated electromagnetic signals received during the noise detection portion of the detection cycle, where the number N is greater than one. The interrogation and detection system may determine a noise value indicative of a noise level based at least in part on the unmodulated electromagnetic signals received during the noise detection portion of the detection cycle by setting the noise value based on the highest one of six samples or measurements of the unmodulated electromagnetic signal received during the noise detection portion of the detection cycle. The interrogation and detection system adjusts a signal detection threshold based at least in part on the determined noise value of at least one of the detection cycles. The interrogation and detection system may adjust the signal detection threshold by adjusting the signal detection threshold based at least in part on a first number of determined noise values indicative of a noise level during at least one noise detection portion that occurred before the receive response portion of a first one of the detection cycles and a second number of determined noise values indicative of a noise level during at least one noise detection portion that occurred after the receive response portion of the first one of the detection cycles. The interrogation and detection system may adjust the signal detection threshold based at least in part on the determined noise value of at least one of the detection cycles by adjusting the signal detection threshold to be approximately twice an average of at least one of the first and the second number of determined noise values. The interrogation and detection system may, for example, adjust the signal detection threshold based at least in part on the determined noise value of at least one of the detection cycles by adjusting the signal detection threshold to be approximately twice a greatest one of at least one of the first and the second number of determined noise values.

**[0289]** The interrogation and detection system emits at least one electromagnetic interrogation signal during a transmit portion of the detection cycle. The interrogation and detection system receives unmodulated electromagnetic signals during a receive response portion of the detection cycle that follows the transmit portion of the detection cycle.

**[0290]** The interrogation and detection system determines the presence or absence of a transponder based at least in part on a number M of samples or measurements of the unmodulated electromagnetic signals received during the detection cycle and the adjusted signal detection threshold, where the number M is greater than one. A ratio of N:M may be at least equal to 4. N may be equal to about 200 and M may be equal to about 800. For example, the interrogation and detection system may determine the presence or absence of a transponder by comparing a maximum value of a plurality of matched filter outputs with the adjusted signal threshold.

**[0291]** In some embodiments, the interrogation and detection system determines if an output of at least one matched filter during the noise detection portion of the detection cycle exceeds a noise fault threshold indicative of a noise fault. Such may be employed to prevent extraneous objects (e.g., metal table, EKG leads, etc.) from producing a positive result. For example, the interrogation and detection system may determine if the output of the at least one matched filter during the noise detection portion of the detection cycle exceeds the noise fault threshold for a defined period of time. The interrogation and detection system may then terminate the detection cycle in response to the output of the at least one matched filter exceeding the noise fault threshold for the defined period of time.

**[0292]** The interrogation and detection system may convert the received signal(s) from the time domain to the frequency domain spectrum. Such may be employed, for example in lieu of the match filtering. The interrogation and detection system may, for example, perform a Fourier transform, for instance a fast Fourier transform such as a 256 point fast Fourier transform. Suitable algorithms and/or sets of software code for performing such are available or can be written. The interrogation and detection system may search the frequency domain spectrum to determine the object with the strongest resonance in a defined frequency band. For example, the interrogation and detection system may search the frequency domain spectrum from about 120 KHz to about 175 KHz. An amplitude of the resonant object may be computed as the sum of the resonant power plus and minus 2 fast Fourier transform bins from the peak resonance frequency. This approach may provide a more accurate measurement of power than simply using the peak value. The frequency of the resonant object may be computed using an interpolation approach. This approach may provide a more accurate determination of resonant frequency than simply using the fast Fourier bin number. The interrogation and detection system may determine the presence or absence of a transponder based at least in part on a frequency of the unmodulated electromagnetic signals received during the detection cycle being within a defined frequency range. The defined frequency range may extend from about 137 KHz to about 160 KHz.

**[0293]** The interrogation and detection system may ignore any unmodulated electromagnetic signals received during a recovery portion (if any) of the detection cycle that precedes the receive response portion of the detection cycle. Such may be useful in preventing false positives (i.e., tag detections) from being triggered by the transmission of the interrogation or excitement signals.

**[0294]** The interrogation and detection system may determine a Q value (i.e., Quality factor) of the resonant object from a signal decay slope for the received unmodulated electromagnetic signal(s) returned by the resonant object. For example, the interrogation and detection system may determine a Q value of the unmodulated electromagnetic signals received during the detection cycle being at least equal to a threshold Q value. The threshold Q value may, for example, be 35. The interrogation and detection system may, for example, use multiple windows, for instance five (5) window positions may provide suitable results. The interrogation and detection system may determine the presence or absence of a transponder based at least in part on a Q value of the unmodulated electromagnetic signal(s) received during the detection cycle. The interrogation and detection

system may preferably employ the Q value determination in conjunction with determination based on the frequency and on the determination based on the adjusted signal detection threshold.

[0295] Consequently, in some embodiments the tag detection may advantageously be based on the received unmodulated electromagnetic signal(s) satisfying all three conditions: 1) measured amplitude is above a threshold, which may be an adjustable threshold, 2) measured frequency is between a lower limit and an upper limit, and 3) measured Q value is above a minimum Q threshold. Interference, for example from RFID tags or EKG cables, are rejected when any of the following three conditions are satisfied: a) measured frequency is below the lower frequency limit, b) measured frequency is above the upper frequency limit, or c) measured Q value is below the threshold Q value. Such may provided significantly superior results over previous approaches, preventing false positives which could otherwise cause a patient to remain open for longer period of time during surgery and tie up hospital personnel and resources.

[0296] The above description of illustrated embodiments, particularly the use of multiple antennas, the pulsed wide band frequency hopping with dynamic adjustment of the transmission frequency in the various frequency bands and the use of switched capacitors to achieve such, advantageously permit the use of inexpensive transponders which are not accurately tuned to a chosen or selected resonant frequency. This is in marked contrast to the approach typically taken with other types of resonant transponders (i.e., transponders without memory). Such approaches typically interrogate or excite the resonant transponder using narrow frequency bands centered closely on specific frequencies, to achieve a selected resonant response from a highly accurate transponder in order to differentiate signal from noise. This is also in marked contrast to the approach typically taken with radio frequency identification (RFID) tags whether active or passive, which also typically employ are narrow band to achieve a selected response from a highly accurate RFID tag.

[0297] The interrogation and detection system herein described may further implement a handheld wand **2802** as illustrated in FIG. 28. Wand **2802** comprises a loop antenna **2806**, a handle **2808**, and a cord **2810**. The wand **2802** may be configured to interface with the interrogation and detection system. The wand **2802** may be connected to the controller **18** by means of the chord **2810**. The wand **2802** may be waved over the patient on the patient support structure **26** while emitting an interrogation signal to excite any transponder **24** which may be in or near the patient. The antennas **16a-16f** may then all be used to detect a signal from the transponder as previously described. In one embodiment the controller **18** controls the wand **2802**. In one embodiment the wand **2802** emits an interrogation signal and monitors for a response from a transponder **24**. In one embodiment the wand **2802** operates independent of the antennas **16** and the controller **18**. In one embodiment the wand **2802** is wirelessly operated. In one embodiment the wand **2802** only detects a transponder and does not emit an interrogation signal. Many other implementations of the wand **2802** will be apparent to those of skill in the art in light of the illustrated embodiments. For example, the wand **2802** may be implemented in a form other than a loop antenna. The illustrated embodiments are given only by way of non-limiting example.

[0298] In some embodiments, the wand **2802** may interact (e.g., inductively) with the other antennas **16** and/or the transponders to, for example, advantageously increase sensitivity and/or range. For example, the antennas **16** may emit interrogation signals and the wand **2802** may be used to detect return or response signals from the transponders. Alternatively, the wand **2802** may emit interrogation signals and the antennas **16** may be used to detect return or response signals from the transponders. Also for example, an electromagnetic field may be set up between the wand **2602** and one or more of the antennas **16**, and disturbances of the electromagnetic field caused by the presence of a transponder therein detected. Other approaches that combined the wand **2802** and one or more of the antennas **16** may be advantageously employed.

[0299] The above-described interrogation and detection system **14** may additionally be utilized to reduce the total number of wired devices used in a medical procedure environment such as a surgical environment and attendant clutter associated with such wired devices. In an operating room or even in most modern patient rooms or clinician's offices there is typically a large number of electronic instruments and equipment used to aid in surgery. This may include various medical instruments which monitor the vital signs or other characteristics or aspects of the patient and hence which may provide telemetry (telemetry medical instruments). A non-exhaustive list of these medical telemetry instruments includes EKG machines, other types of electrogram devices, pulse oximeters, intracranial pressure monitors, blood pressure monitors, thermometers or other temperature sensitive devices, pH sensors, electrical conductivity sensors, etc. There may also be life support equipment, for example, cardiopulmonary bypass machines, ventilators, intra-aortic balloon pumps, an infusion pumps, etc. All of these instruments may comprise one or more wires including power cords and wires that extend between the patient and the instrument and/or monitors or displays. These wires may be an obstacle to medical personnel performing or assisting in the surgery. This may put the patient at risk, as well as increase the risk of damaging the equipment. Additionally, many of these cords and wires must be sterilized after each use. Sterilizing a wire can be extremely expensive since inventory control must be maintained, wires are typically difficult to sterilize, and repeated sterilization may shorten the useful life of the wire.

[0300] The interrogation and detection system **14** described herein may advantageously enable the wireless operation of many systems and instruments in a surgical environment. As described above in relation to FIGS. 1-28 the interrogation and detection system **14** may comprise antennas **16** embedded in a patient support structure **26**, or situated in other configurations throughout the operating room. The interrogation and detection system **14** may further comprise a controller **18** configured to control the operation of the antennas **16**. The antennas **16** and controller **18** comprise a useful infrastructure which reduces a total number of wires used in the vicinity of a patient. The reduction of wires can reduce complications and costs of surgery.

[0301] FIG. 29 shows an environment in which medical procedures (e.g., therapeutic and/or diagnostic medical procedures) are performed, according to one illustrated embodiment. As previously noted, the medical procedure environ-

ment may take a variety of forms such as an operating room or theater, a patient room, examination room, a clinician's office, etc.

[0302] The medical procedure environment includes a plurality of antennas 2916a-2916f (collectively 2916). As illustrated, some or all of the antennas 2916 may be carried by a patient support structure 2926 (e.g., operating table, bed, pads, mattress). Alternatively, one or more of the antennas 2916 may be located elsewhere in the medical procedure environment, for example carried by a light fixture or associated shade, a curtain or drape, etc.

[0303] The medical procedure environment may include a controller 2918 communicatively coupled to one or more of the antennas 2916. The controller 2918 is preferably communicatively coupled to the antenna(s) 2916 via one or more wired communications channels, for example via one or more cables, for instance shielded coaxial cables (not shown in FIG. 29). The controller 2918 may, for example, be positioned on or within a pedestal 2928 which supports the patient support structure 2926.

[0304] As previously described, one or more of the antennas 2916 may emit interrogation signals and receive responses to interrogation signals in order to detect a presence or absence of transponders which mark various types of objects used in medical procedures, for instance instruments, implements, and various other supplies such as sponges, pads, gauze. Thus, the controller 2918 may provide a notification (e.g., visual, aural, tactile) in response to a detection of a presence or absence of a transponder in the range of one or more of the antennas 2916. Advantageously, one or more of the antennas 2916 may also be used to provide wireless communications with one or more pieces of dedicated medical diagnostic, therapeutic or monitoring equipment 2959a, 2059b (collectively 2959). The dedicated medical diagnostic, therapeutic or monitoring equipment 2959 may include one or more antennas 2961a, 2961b, receivers, transmitters and/or transceivers (not shown in FIG. 29) to provide wireless communications to and/or from the dedicated medical diagnostic, therapeutic or monitoring equipment 2959. As explained in more detail with respect to other Figures below, the antennas 2916 may serve as a relay between pieces of dedicated medical diagnostic, therapeutic or monitoring equipment 2959, for example as a relay between sensors (not illustrated in FIG. 29) and a dedicated controller or control system of a piece of dedicated medical diagnostic, therapeutic or monitoring equipment 2959, remotely located from the sensors. Additionally, or alternatively, the controller 2918 of the interrogation and detection system 2914 may serve as a user interface to display information from and/or to interact with the pieces of dedicated medical diagnostic, therapeutic or monitoring equipment 2959, for instance as described directly below.

[0305] A display 2950 and a user input device 2952 may be communicatively coupled to the controller 2918. The display 2950 may be any screen or monitor (e.g., LCD panel, CRT) suitable to display information and/or a user interface (e.g., graphical user interface). The display 2950 may be a touch-sensitive display device, capable of functioning as a user input device of a user interface. The display 2950 may be a stand alone, separate piece of equipment. Alternatively, the display 2950 may be integrated into the controller 2918 or the patient support structure 2926.

[0306] The display 2950 and/or user input device 2952 may be a dedicated medical telemetry terminal or part of a

piece of dedicated medical diagnostic, therapeutic or monitoring equipment 2959. Alternatively, the display 2950 and/or user input device 2952 may be general purpose equipment capable of providing display of information from, and/or control over, a variety of pieces of dedicated medical diagnostic, therapeutic or monitoring equipment 2959.

[0307] The display 2950 may be configured to display medical telemetry or data received via antennas 2916. The medical telemetry or data may be received by one or more of the antennas 2916 from one or more of a variety of medical telemetry devices such as dedicated medical diagnostic, therapeutic or monitoring equipment 2959 (e.g., EKG sensors or electrodes, intra-cranial pressure sensors, pulse oximetry sensors or pulse oximeters, or any other of numerous medical measurement or sensor devices). The medical telemetry or data may be related to a characteristic or physiological condition of a patient. Alternatively, or additionally, the telemetry or data may be related to one or more operational characteristics of the dedicated medical diagnostic, therapeutic, or monitoring equipment themselves, whether equipment dedicated to medically related measurement or sensing, or equipment that performs a therapeutic function on the patient. The telemetry or data may be conveniently displayed by the display 2950, either in processed and/or raw form. Processing may be performed by the dedicated medical diagnostic, therapeutic or monitoring equipment 2959 or by the controller 2918 of the interrogation and detection system 2914. Telemetry or data from multiple pieces of dedicated medical diagnostic, therapeutic or monitoring equipment 2959 may be displayed sequentially or concurrently (e.g., substantially simultaneously) on the display 2950.

[0308] One or more of the antennas 2916 of the interrogation and detection system 2914 may communicate with the dedicated medical diagnostic, therapeutic or monitoring equipment, for example receiving data from, and/or providing data, instructions and/or new programs to the dedicated medical diagnostic, therapeutic or monitoring equipment. For example, one or more of the antennas 2916 may relay commands to the dedicated medical diagnostic, therapeutic or monitoring equipment such as a cardiopulmonary bypass machine, ventilator, intra-aortic balloon pump, infusion pump, etc. Also for example, one or more of the antennas 2916 may relay data or telemetry from the dedicated medical diagnostic, therapeutic or monitoring equipment, such as an EKG electrodes, pulse oximetry sensors, blood pressure sensors, intracranial pressure monitor sensors, etc. The user input device (e.g., keyboard, keypad, pointer device, and/or graphical user interface) 2952 can be used to instruct the controller 2918 to control one or more of the dedicated medical diagnostic, therapeutic or monitoring equipment in wireless communication with the interrogation and detection system 2914. These pieces of dedicated medical diagnostic, therapeutic or monitoring equipment or instruments (e.g., life support equipment) are not shown in FIG. 29, but one or more may be present in the environment in which medically related diagnostic, therapeutic and/or monitoring procedures are performed. Exemplary embodiments of dedicated medical diagnostic, therapeutic or monitoring equipment which can communicate via one or more of the antennas 2916 are described below.

[0309] The medical procedure environment may include one or more automatic data collection readers 2990a, 2990b (collectively 2990, only two illustrated). The automatic data

collection readers **2990** are dedicated to reading and/or writing data to one or more data carriers **2924a-2924d** (collectively **2924**, only three illustrated), hence may be denominated as dedicated automatic data collection readers herein and in the claims. Such denomination means that the dedicated automatic data collection readers **2990** perform only reading and/or writing to data carriers **2924**, and are not otherwise used to measure or sense physiological conditions of a patient or therapeutically interact with a patient.

[0310] The dedicated automatic data collection readers **2990** may, for example, take the form of, or include, a machine-readable symbol reader **2990a**, for instance a scanner or imager capability of optically reading machine-readable symbols **2924c** (e.g., barcode, area or matrix code or stacked code symbols). Also for example, the dedicated automatic data collection readers **2990** may take the form of, or include, a radio frequency identification (RFID) reader **2990b**, for instance an RFID interrogator capability of wirelessly reading information from an RFID data carrier such as an RFID tag **2924b**. The dedicated automatic data collection readers **2990** may combine machine-readable symbol and RFID reading capabilities. Suitable dedicated automatic data collection readers **2990** may be commercially available from Intermec Technologies or Symbol Technologies. Additionally, or alternatively, the dedicated automatic data collection readers **2990** may be capable of reading or writing to other data carriers such as optical memories, touch memories (e.g., available from Dallas Semiconductor), magnetic stripes, etc.

[0311] The data carriers **2924** may take a large variety of forms, including but not limited to labels or tags that carry machine-readable symbols or that otherwise encode machine-readable information (e.g., RFID, optical memories, touch memories, magnetic stripes). The data carrier **2924** may advantageously encode information in two or more forms, for example an RFID transponder that carries or bears a machine-readable symbol. Also for example, the data carrier **2924** may include a transponder and an RFID transponder. Details of such are discussed in U.S. patent application Ser. No. 12/472,199 filed May 26, 2009, as well as in U.S. provisional patent applications Ser. Nos. 61/056,299 and 61/102,749, filed May 27, 2008 and Oct. 3, 2008, respectively, and which are incorporated by reference herein in their entireties.

[0312] The dedicated automatic data collection readers **2990** may include one or more processors and/or memory. The dedicated automatic data collection readers **2990** may be configured to process or pre-process information read from the data carrier. For example, the dedicated automatic data collection readers **2990** may be configured to automatically recognize symbols from various symbologies and decode the same. The dedicated automatic data collection readers **2990** may be configured to write data to a data carrier **2924**. For example, the dedicated automatic data collection reader **2990b** may be configured to automatically write information to an RFID data carrier **2924**.

[0313] The dedicated automatic data collection readers **2990** may be communicatively coupled to the controller **2918**, either via a physical or wired channel (e.g., electrical or optical) as illustrated for the reader **2990a** or wirelessly as illustrated for the reader **2990b**. Wireless communications may occur via one or more of the antennas **2916** of the interrogation and detection system. While FIG. **29** illustrates all antennas **2916** of the interrogation and detection system

as being carried by the patient support structure, one, more or all of the antennas of the interrogation and detection system may be carried by other structures, for example a shade associated with a light fixture or a drape. The dedicated automatic data collection readers **2990** may form part of a network, along with the communications channel(s) and controller **2918**.

[0314] The dedicated automatic data collection readers **2990** may be employed to read information from data carriers **2924** physically associated with various objects (e.g., implements **2922a**, tools, machines **2922d**, devices, sponges **2922b**, pads, gauze, articles and/or other supplies), and/or a patient and/or one or more medical care providers (e.g., doctors, nurses, anesthesiologist, radiology technician), for instance from a data carrier of a wrist band **2922c**, ankle or badge worn by the patient or medical care provider. Such can be integrated with other automatically collected information, such as information indicative of a physiological condition of the patient or subject, or information indicative of an operational parameter of a piece of dedicated medical diagnostic, therapeutic or monitoring equipment.

[0315] In addition to the dedicated automatic data collection readers **2990**, or alternatively, one or more of the antennas **2916** of the interrogation and detection system may be used to read from, and/or write to, data carriers **2924**. For example, the controller **2918** may be configured to cause one or more of the antennas **2916** to emit interrogation signals in a frequency band employed by RFID transponders or tags, and to receive response signals encoding information from the RFID transponder's memory.

[0316] Information received from the RFID transponder may, for example, include an identifier, such as a unique identifier that uniquely identifies the RFID transponder or tag. A database stored on a computer-readable medium may associate the identifier with information that identifies the object to which the RFID transponder or tag is attached, as well as information about the object. The information may include identity of the object such as manufacturer, model, type, classification, lot number and/or date of manufacture. The information may include a history of the object, for instance number of uses, number and/or type of sterilization cycles, number and/or date of refurbishment, dates and/or times of use, dates of inspection and/or identity of inspector. The information may be accessible (e.g., read, write) by the controller **2918** of the interrogation and detection system, and/or by one or more pieces of dedicated medical diagnostic, therapeutic or monitoring equipment.

[0317] An EKG machine may be used to monitor the heart activity of a patient during surgery. Conventionally, a plurality of electrodes or sensors are attached to a patient at various locations on the patient. Each electrode or sensor is electrically coupled to the EKG machine by a respective electrically conductive wire. Each EKG electrode and wire is commonly referred to as a lead. As many as twelve or more electrodes may be attached to the patient simultaneously, each electrode having its own wire coupled to an EKG machine. EKG lead wires can be particularly obtrusive during surgery. The EKG lead wires frequently become tangled. Medical personnel moving about the patient are impeded by the wires. Medical personnel may bump into the wires and either break a wire or detach one or more of the EKG electrodes. Once detached, the electrodes may be difficult to reattach as there may be bodily fluid covering the area where the detached electrode was previously attached.

If more than one electrode becomes detached, the electrodes are particularly susceptible to being replaced in the wrong location. Also, fluid on the electrodes may cover a distinguishing mark meant to indicate the proper location of the electrodes. Reattaching the electrodes wastes valuable time and can lead to improper placement of the electrodes and faulty EKG data. Reducing the amount of wires leading from the EKG electrodes to an EKG machine is desirable.

[0318] FIG. 30A shows a piece of dedicated medical diagnostic, therapeutic or monitoring equipment in the form of wireless sensor or transducer 3054, according to one embodiment. The wireless sensor or transducer may take the form of an electrode 3054a, for instance an electrode suitable for measuring EKGs. While such may be referred to as a “wireless lead,” applicants understand that such term is somewhat a misnomer since the “lead” or electrical wire is eliminated and all that remains of the original “lead” is the electrode (i.e., electrically sensitive sensor or transducer).

[0319] The wireless sensor or transducer 3054 carries a battery 3056 and a radio 3058. The radio 3058 comprises at least a transmitter and may include a receiver as well, and may be formed as a transceiver. The wireless sensor or transducer 3054 may also include an inscription or marker indicating a proper position of the wireless sensor or transducer 3054 on the body of the patient. The individual wireless electrodes 3054a may sense activity of the heart or other physiological activity (e.g., electrical) in any suitable manner. While illustrated as an active component having a discrete exhaustible power source (e.g., chemical battery, fuel cell), the wireless sensor or transducer 3054 may take a passive form, deriving power from a wireless interrogation signal, similar to radio frequency identification (RFID) transponders. While discussed in terms of an electrode 3054a to sense electrical physiological characteristics (e.g., conductivity, impedance, resistivity, capacitance), a wireless sensor or transducer 3054 can be employed which is responsive to other physiological characteristics (e.g., temperature, moisture, pH, salt, pressure, stress, strain or force).

[0320] FIG. 30B shows a plurality of “wireless leads” or electrodes 3054a attached to a patient 3060 according to one embodiment.

[0321] As described above, a patient may have twelve or more EKG electrodes positioned on the torso, back, limbs, or any suitable location. The configuration of the wireless electrodes 3054a in FIG. 30B is given only by way of broad example of the number and positioning of the wireless electrodes 3054a. In practice, the number and positioning of wireless electrodes 3054a may be different from that shown in FIG. 30B.

[0322] Each wireless electrode 3054a comprises a radio 3058 configured to transmit EKG data to an antenna 16 coupled to the interrogation and detection system 14. In one embodiment the controller 18 processes the data received from the wireless electrodes 3054a and displays the resulting EKG waveform on the display 2950 (FIG. 29).

[0323] Each wireless electrode 3054a may transmit a unique identifier to the controller 18 so that the controller 18 may know which data came from which wireless electrode 3054a. The identifier may also indicate the position of an individual wireless electrode on the patient’s body. The electrodes 3054a may bear a marking which identifies the wireless electrode 3054a and/or a location on the body at which the wireless electrode 3054a should be placed or is placed.

[0324] Two or more electrodes 3054a may be wirelessly communicatively coupled to each other. Two wireless electrodes 3054a are wirelessly coupled when at least one of the wireless electrodes 3054a is configured to transmit data to the other wireless electrode 3054a. One wireless electrode 3054a can send a signal to a second wireless electrode 3054a and the second wireless electrode 3054a can then transmit data to the antenna 16 representing the data gathered by one or both wirelessly coupled wireless electrodes 3054a. The controller 18 may receive wireless transmissions from only one or from both wireless electrodes 3054a.

[0325] The configuration shown in FIG. 30B greatly reduces the number of wires in the vicinity of the patient. Medical personnel moving about the patient support structure 2726 will face a much lower risk of bumping a wire and either detaching an electrode 2854 or stumbling themselves. There are fewer wires on the body of the patient to impede surgeons performing delicate and precise operations on the body of the patient. In addition to this, the EKG machine no longer needs to be present in the surgical environment. The controller 18 may process the data sent from the electrodes 3054a and displays the data (e.g., EKG waveform) on the display 2950 (FIG. 29).

[0326] While it has been noted that the dedicated piece of medical diagnostic, therapeutic or monitoring equipment (e.g., EKG machine) may not be present in the medical procedure environment, typically the dedicated piece of medical diagnostic, therapeutic or monitoring equipment will be co-located in the same room as the patient. The wireless electrodes 3054 may wirelessly transmit telemetry or data to a piece of dedicated medical diagnostic, therapeutic or monitoring equipment (e.g., an EKG machine). The piece of dedicated medical diagnostic, therapeutic or monitoring equipment may in turn transmit data to the controller 18 of the interrogation and detection system, for example via the antennas 16 or via one or more wired connections (e.g., electrically conductive cables or optical fiber cables). The controller 18 may also transmit instructions to the piece of piece of dedicated medical diagnostic, therapeutic or monitoring equipment. For example, the controller 18 may transmit operating instructions which cause the piece of piece of dedicated medical diagnostic, therapeutic or monitoring equipment to operate in a certain fashion, or may transmit new software or firmware instructions or upgrades of existing software or firmware instructions, to reconfigure the piece of piece of dedicated medical diagnostic, therapeutic or monitoring equipment. Alternatively, one or more of the antennas 2916 (FIG. 29) may provide wireless communications between the display 2950, user input device 2952 and the piece of piece of dedicated medical diagnostic, therapeutic or monitoring equipment, which may employ conventional wired electrodes (not shown).

[0327] FIG. 30C shows sensor or transducer 3054 according to an alternative embodiment. One electrode 3054a may be connected by a wire 3062 to another wireless lead or electrode 3054a. One or both of the electrodes 3054a comprises a radio 3058 (i.e., transmitter and/or receiver or transceiver that communicates via portions of the electromagnetic spectrum typically associated with radio communications such as the radio and microwave portions of the electromagnetic spectrum) and optionally a discrete consumable power source such as battery 3056 or fuel cell. At least one of the pair of wireless electrodes 3054a transmits

telemetry or data (e.g., EKG signals) to one or more of the antennas **16** of the interrogation and detection system **14**. There may be one or more pairs of wireless electrodes **3054a** attached to the patient in which one wireless electrode **3054a** of each pair is wired to the other wireless electrode **3054a** of the pair.

[0328] FIG. **31** shows a plurality of sensors or transducers **3154** in the form of leads or electrodes **3154a** and an intermediary relay **3164**, according to one illustrated embodiment.

[0329] The leads **3154a** may, for example, include an electrode, sensor or other transducer, and a physical communications conduit, for example an electrically conductive or optical wire or cable. Each of the leads **3154a** is attached to a patient **3160** at various locations on the patient to sense a physiological characteristic of the patient. Each lead **3154a** is also communicatively attached or coupled to the intermediate relay **3164**. The intermediate relay **3164** is a commonly shared communications device **2964** (i.e., common communications device shared by two or more of the leads **3154a**), and is interchangeably referred to as such herein.

[0330] The intermediate relay or common communications device **3164** may take the form of, or include, a multiplexer and/or demultiplexer. The common communications device **2964** includes a radio **3158** operable to transmit telemetry or data (e.g., signals) detected by the leads **3154a** to one or more of the antennas **16** of the interrogation and detection system **14**. The radio **3158** includes one or more antennas, a transmitter and may also include a receiver, and may be formed as transceiver. The common communications device **3164** may be powered by a battery **3156** or other power source. The leads **3154a** may be powered by respective batteries located at the electrode portions of the leads **3154a**. Alternatively, the leads **3154a** may receive power from the intermediate relay or common communications device **3164** via the respective wires. As a further alternative, the leads **3154a** may wirelessly receive power via an interrogation signal.

[0331] The intermediate relay or common communications device **3164** wirelessly transmits telemetry or data (e.g., EKG signals) to the controller **18** of the interrogation and detection system via one or more antennas **16**. The controller **18** may display the telemetry or data on the display **2950** (FIG. **29**), either in processed or raw form. Alternatively, the controller **18** may communicate the telemetry or data to a piece of dedicated medical diagnostic, therapeutic or monitoring equipment. For instance, the controller **18** may relay the telemetry or data to an EKG machine for processing and display or printing. Such may take place over a physical media, such as electrical wires or optical fibers. This advantageously eliminates many of the wires around the patient **3160** which would have connected the leads **3154a** directly to an EKG machine. The EKG machine likewise may not be needed as the common communications device **3164** and the controller **18** may process the EKG data.

[0332] Another piece of dedicated medical diagnostic, therapeutic or monitoring equipment that provides dedicated medical telemetry or data is a pulse oximeter. A typical pulse oximeter sensor is attached to a finger of a patient to measure the blood-oxygen level of a patient. The pulse oximeter sensor is normally connected by one or more wires to a pulse oximeter processing system to process raw data from pulse oximeter sensor. The pulse oximeter processing system includes or is coupled to a display to display processed data.

[0333] FIG. **32** shows a wireless pulse oximeter sensor **3266**, according to one embodiment. The pulse oximeter sensor **3266** may be used to monitor the oxygen content of a patient's blood.

[0334] The wireless pulse oximeter sensor **3266** is physically attached to a portion of the patient, for example a finger **3268** of the patient. The wireless pulse oximeter sensor **3266** comprises a transducer **3257** and a radio **3258** transmitter and/or receiver or transceiver). The radio **3258** includes an antenna (now shown) and is configured to wirelessly transmit data sensed by the transducer **3257** to at least one antenna **16** coupled to the interrogation and detection system **14**. The controller **18** may process the data received via the at least one antenna. The controller **18** may display the patient's blood-oxygen data on the display **2950** (FIG. **29**) in processed or raw form. The data may advantageously be displayed simultaneously with EKG data on a single display **2950** (FIG. **29**). Of course, more than one display **2950** may be utilized. Alternatively, the controller **18** may relay the sensed measurements to a dedicated pulse oximeter processing system or controller, either via wireless or wired communications. Thus, the interrogation and detection system **14** may advantageously be utilized to eliminate extraneous wire, and/or an extra display or processor.

[0335] Hence, some embodiments may take advantage of the proximity of antennas **16** to the patient to wirelessly collect data from various sensors or transducers, and to relay that data directly to associated processing equipment dedicated to a particular function or task. Alternatively, the controller **18** of the interrogation and detection system **14** may itself implement some or all of the processing usually performed by the associated dedicated processing system.

[0336] FIG. **33** illustrates an intracranial pressure monitor **3370** according to one embodiment.

[0337] The intracranial pressure monitor **3370** is a dedicated piece of medical diagnostic, therapeutic or monitoring equipment which is attached to a head of the patient to monitor pressure in the head. The intracranial pressure monitor **3370** may include one or more pressure sensors or transducers (e.g., piezo-electric or resistance based strain gauge) **3371** and a radio **3372** (i.e., transmitter and/or receiver or transceiver) that includes an antenna (not shown). The pressure sensors or transducers **3371** may be implemented in a MEMS device or other suitable mechanism. The radio **3372** is communicatively coupled to the pressure sensor **3371**. The radio **333172** transmits data from the pressure sensor or transducer **3371** to an antenna **16** of the interrogation and detection system **14**.

[0338] The controller **18** may process the data and display the processed data on the display **2950** (FIG. **29**). Alternatively, the controller **18** may simply display raw, unprocessed data via the display **2950**. Additionally, or alternatively, the controller **18** may relay the raw or partially processed data to a controller of a dedicated intracranial pressure monitor processing system or controller. In one embodiment, the display **2950** (FIG. **29**) advantageously displays intracranial pressure monitor sensor data along with pulse oximetry and/or EKG data collected from one or both of the pulse oximeter **3266** (FIG. **32**) and/or electrodes **3054** (FIG. **30A**). When processing occurs in dedicated medical diagnostic, therapeutic or monitoring equipment, that dedicated medical diagnostic, therapeutic or monitoring equipment may relay processed data back to the interrogation and detection system **14**, via antennas **16**, for display on display

2950, possibly with other processed data. Alternatively, the dedicated medical diagnostic, therapeutic or monitoring equipment may be communicatively coupled directly to the display 2950, for example via one or more wired or wireless connections.

[0339] The interrogation and detection system 14 can further be utilized to communicate with and issue commands to other dedicated medical diagnostic, therapeutic or monitoring equipment, for example dedicated medical therapeutic equipment used to perform a therapeutic function on the patient or dedicated medical diagnostic equipment used to collect diagnostic information from the patient.

[0340] FIG. 34 illustrates an infusion pump 3474 according to one illustrated embodiment.

[0341] The infusion pump 3474 is a piece of dedicated medical diagnostic, therapeutic or monitoring equipment that may be used to inject fluid (e.g., intravenously) into a patient. The fluid may be one or more drugs, anesthetic, blood, plasma, saline, food or sucrose, etc. The infusion pump 3474 may be programmed to introduce fluid into the patient at a desired rate. The infusion pump 3474 may include a radio (e.g., transmitter and/or receiver, or transceiver) 3458 configured to communicate wirelessly with an antenna 16 of the interrogation and detection system 14. The radio 3458 may receive wireless control signals from a remotely located controller, for instance the controller 18. The control signals may indicate, for example, an infusion rate at which to pump the fluid into the patient, a start time, a stop time, a duration, a delivery profile indicating various rates over time. The radio 3458 may additionally or alternatively, transmit monitoring signals to a remotely located controller, for instance the controller 18. The monitoring signals may indicate various operational characteristics of the infusion pump 3474, for instance, amount and/or rate of actual fluid delivery, an amount of fluid remaining, and whether a battery of the infusion pump 3474 is nearing depletion. The data from the infusion pump 3474 may be displayed on the display 2950 (FIG. 29) along with other medical telemetry or data described in relation to FIGS. 30-33. Additionally, or alternatively, the medical telemetry or data may be relayed by the controller 18 of the interrogation and detection system 14 to a dedicated controller of an infusion pump system. Such may be done over one or more wired or wireless communications channels.

[0342] In one embodiment, a user may use the input device 2952 and/or touch screen of the display 2950 (FIG. 29) to enter a new fluid infusion rate for the infusion pump 3474. The controller 18 then sends a control signal to the infusion pump 3474 via an antenna 16 of the interrogation and detection system 14. Alternatively, the user may enter a new rate via a user input device of a dedicated infusion pump system, which relays control instructions to the interrogation and detection system 14. The signal is received at the radio 3458 of the infusion pump 3474 and the infusion pump 3474 adjusts the fluid infusion rate accordingly.

[0343] The controller 18 may be configured to communicate with remotely located equipment, such as a display at a nurse's station outside of the room in which the medical procedure is preformed. Any of the data received by the controller 18 can be displayed at the nurse's station. In this way medical personnel remote to the patient's room may monitor any of the equipment communicating with the interrogation and detection system 14.

[0344] The controller 18 may be configured to receive commands from the nurse's station to adjust the fluid infusion rate of the infusion pump 3474. The controller 18 may be configured to receive commands from the nurse's station to adjust a function of any of the equipment coupled to the interrogation and detection system.

[0345] FIG. 35 illustrates an intra-aortic balloon pump system 3576, according to one illustrated embodiment. Typically, a balloon pump system is a dedicated piece of medical diagnostic, therapeutic or monitoring equipment used to inflate or deflate catheter balloons. The balloon pump system is typically controlled by a computer coupled to an EKG machine. The computer controls the pulsation of the balloon pump according to data from the EKG.

[0346] The intra-aortic balloon pump system 3576 comprises a pump 3577 operable to selectively inflate and deflate an intra-aortic balloon. The intra-aortic balloon pump system 3576 may include a user interface 3578 including a display 3578a and one or more user input devices (e.g., keys, switches, knobs, pointer devices) 3578b. The display 3578a and user input devices 3578b are dedicated to the display of information related to operation of the aortic balloon pump system 3576 and control thereof, respectively.

[0347] The intra-aortic balloon pump system 3576 may include a radio (e.g., transmitter and/or receiver or transceiver) 3558 configured to communicate with an antenna 16 of the interrogation and detection system 14. The controller 18 may be configured to control the balloon pump 3576 from a remote location, for example in response to EKG data. The controller 18 may transmit data, for instance EKG data, to the balloon pump system 3576 and allow the balloon pump system 3576 to process the data and control the pump 3577 accordingly. In either case, the balloon pump system 3576 does not need to be connected by wire to another piece of dedicated medical diagnostic, therapeutic or monitoring equipment (e.g., EKG machine), thus enhancing the environment in which the medical procedure is preformed. Alternatively, or additionally, the interrogation and detection system 14 may function as a relay between sensors or transducers (e.g., electrodes), pumps (e.g., pump of intra-aortic balloon system) and other dedicated medical diagnostic, therapeutic or monitoring equipment or dedicated medical diagnostic, therapeutic or monitoring control systems of such dedicated medical diagnostic, therapeutic or monitoring equipment. The interrogation and detection system 14 may be further utilized to interact with a balloon pump during or after surgery.

[0348] FIG. 36 illustrates a controller 3618, according to one illustrated embodiment.

[0349] The controller 3618 is similar to that of FIG. 16 but has been adapted to enable operation of the antennas 16 to communicate with pieces of dedicated medical diagnostic, therapeutic or monitoring equipment as described in relation to FIGS. 29-34. The controller 3618 comprises a motherboard 3672. The motherboard 3672 includes or is communicatively coupled to a plurality of ports or connectors 3674 to communicatively couple the motherboard 3672 to respective antennas 16 as previously described in relation to FIG. 16. The motherboard 3672 may also include slot connectors 3676 to receive plug-in boards 3678 as previously described in relation to FIG. 16. The controller 3618 has been expanded to include one or more additional slot connectors 3676 for receiving one or more additional plug-in boards 3678 for enabling communication through the antennas 16

or additional antenna(s) with one or more medical telemetry or data and support or control pieces of dedicated medical diagnostic, therapeutic or monitoring equipment, for example equipment such as EKG electrodes 3054, pulse oximeter sensor 3266, intracranial pressure monitor 3370, fusion pump 3474, and balloon pump system 3576. There are of course many other dedicated medical diagnostic, therapeutic or monitoring equipment which may be used during and after a medical procedures (e.g., operation), any or all of which may be fitted with radios (e.g., transmitter and/or receiver, or transceiver) and configured to interface with the interrogation and detection system. The one or more additional plug-in boards 3676 enable the controller 3618 to operate the interrogation and detection antennas 16 in a mode for interacting with pieces of dedicated medical diagnostic, therapeutic or monitoring equipment.

[0350] A single antenna 16 of the interrogation and detection antennas may be dedicated to communicate with the pieces of dedicated medical diagnostic, therapeutic or monitoring equipment. Alternatively more than one antenna 16 of the interrogation and detection system 14 may be configured to communicate with the pieces of dedicated medical diagnostic, therapeutic or monitoring equipment. In some embodiments, all of the antennas 16 of the interrogation and detection system 14 are configured to communicate with the pieces of dedicated medical diagnostic, therapeutic or monitoring equipment. In some embodiments, one or more of the antennas 16 of the interrogation and detection system 14 are dedicated to communications with the pieces of dedicated medical diagnostic, therapeutic or monitoring equipment, the plug-in boards being different from the plug-in board used with antennas 16 that perform interrogations to locate transponders 24. In some embodiments, one or more antennas 16 are used to perform all of interrogation, detection of transponders and to communicate with sensors, pumps, and/or other instruments or equipment, and/or with dedicated control systems of the same. In some embodiments, one or more additional antennas 16 may be connected to ports 3674 of the motherboard 3672 dedicated solely to interface with the pieces of dedicated medical diagnostic, therapeutic or monitoring equipment.

[0351] The controller 18 of the interrogation and detection system may be operable to communicate with radios 3058, 3258, 3372, 3458, 3558 of the various pieces of dedicated medical diagnostic, therapeutic or monitoring equipment 3054, 3266, 3370, 3474, 3576. Radios 3058, 3258, 3372, 3458, 3558 may operate in more precise frequency bands than the transponders 24.

[0352] Antennas of the interrogation and detection system 14 may be configured to operate in a first mode to detect transponders 24 and in a second mode to communicate with the pieces of dedicated medical equipment. The first mode may include operating in a first broad frequency range as previously described with regards to the interrogation and detection process. The second mode may include operating in a second frequency range, more narrow than the first frequency range. In one embodiment, the first and second frequency ranges may overlap. In other embodiments, the first and second frequency ranges do not overlap.

[0353] In an alternative embodiment, the radios may be passive, employing passive RFID type technology. Such radios may employ a first antenna dedicated solely to receiving a first signal to charge a charge pump of the radio to power the radio. The second antenna operates at a

different frequency than the first antenna and is configured to communicate with an antenna 16 of the interrogation and detection system 14. A dedicated power antenna may be installed in the interrogation and detection system 14 to supply a constant signal to power EKG wireless leads or electrodes 3054. Alternatively the power antenna could be installed in the operating room independent of the interrogation and detection system 14. In either case, the power antenna should be near the patient support structure 26 in order to supply an adequately strong signal to the radios. In one embodiment the power generated by the charge pump supplements the battery 3056 to extend the life thereof in the case of a long medical procedure which may last several hours. Otherwise, the battery 3056 of the wireless leads or electrodes 3054 may run out of power. Thus, the power generated by the charge pump from the power antenna signal may advantageously prolong the life of the battery 3056. The radios may also comprise two antennas to supplement the batteries of the pieces of dedicated medical diagnostic, therapeutic or monitoring equipment.

[0354] The above description of illustrated embodiments, including what is described in the Abstract, is not intended to be exhaustive or to limit the embodiments to the precise forms disclosed. Although specific embodiments of and examples are described herein for illustrative purposes, various equivalent modifications can be made without departing from the spirit and scope of the disclosure, as will be recognized by those skilled in the relevant art. The teachings provided herein of the various embodiments can be applied to other transponders and interrogation and detection systems, not necessarily the exemplary surgical object transponders and interrogation and detection systems generally described above.

[0355] For instance, the teachings herein may employ any variety of other electrodes, sensors or transducers and diagnostic, therapeutic or monitoring equipment. For example, photo-electric pulse plethysmograph transducers, respiratory effort transducers, GSR finger electrode transducers, physiological sounds microphone, active electrodes, air flow transducers, blood pressure transducers, blood pressure cuff transducers, hand dynamometers, variable range force transducer, twin axis goniometer, torsion meter, laser Doppler surface flow probe, skin surface temperature, fast response temperature probe, surface temperature banjo probe, liquid immersion probe, digit surface temperature probe, accelerometer, pulse oximeters transducer.

[0356] Also for instance, the foregoing detailed description has set forth various embodiments of the devices and/or processes via the use of block diagrams, schematics, and examples. Insofar as such block diagrams, schematics, and examples contain one or more functions and/or operations, it will be understood by those skilled in the art that each function and/or operation within such block diagrams, flowcharts, or examples can be implemented, individually and/or collectively, by a wide range of hardware, software, firmware, or virtually any combination thereof. In one embodiment, the present subject matter may be implemented via Application Specific Integrated Circuits (ASICs). However, those skilled in the art will recognize that the embodiments disclosed herein, in whole or in part, can be equivalently implemented in standard integrated circuits, as one or more computer programs running on one or more computers (e.g., as one or more programs running on one or more computer systems), as one or more programs running on one or more

controllers (e.g., microcontrollers) as one or more programs running on one or more processors (e.g., microprocessors), as firmware, or as virtually any combination thereof, and that designing the circuitry and/or writing the code for the software and or firmware would be well within the skill of one of ordinary skill in the art in light of this disclosure.

[0357] In addition, those skilled in the art will appreciate that the mechanisms of taught herein are capable of being distributed as a program product in a variety of forms, and that an illustrative embodiment applies equally regardless of the particular type of physical signal bearing media used to actually carry out the distribution. Examples of signal bearing media include, but are not limited to, the following: recordable type media such as floppy disks, hard disk drives, CD ROMs, digital tape, and computer memory.

[0358] The various embodiments described above can be combined to provide further embodiments. To the extent not inconsistent with the teachings herein, all U.S. patents, U.S. patent application publications, U.S. patent applications, foreign patents, foreign patent applications and non-patent publications commonly owned with this patent application and referred to in this specification and/or listed in the Application Data Sheet including: U.S. Patent Publication No. US 2004/0250819, published Dec. 16, 2004; U.S. Provisional Patent Application No. 60/811,376 filed Jun. 6, 2006; U.S. Provisional Patent Application No. 61/109,104 filed Oct. 28, 2008; U.S. Provisional Patent Application No. 61/222,443 filed Jul. 1, 2009; U.S. Provisional Patent Application No. 61/222,847 filed Jul. 2, 2009; U.S. Provisional Patent Application No. 61/242,704, filed Sep. 15, 2009 and entitled "METHOD AND APPARATUS TO DETECT TRANSPONDER TAGGED OBJECTS, FOR EXAMPLE DURING MEDICAL PROCEDURES"; U.S. provisional patent application Ser. No. 61/242,699 filed Sep. 15, 2009; U.S. Non-Provisional patent application Ser. No. 11/743,104 filed May 1, 2007; U.S. Non-Provisional patent application Ser. No. 12/472,199 filed May 26, 2009; U.S. Non-Provisional patent application Ser. No. 12/473,059 filed May 27, 2009; and U.S. Pat. No. 6,026,818, issued Feb. 22, 2000, are incorporated herein by reference, in their entirety. Aspects of the embodiments can be modified, if necessary, to employ systems, circuits and concepts of the various patents, applications and publications to provide yet further embodiments.

[0359] These and other changes can be made to the embodiments in light of the above-detailed description. In general, in the following claims, the terms used should not be construed to limit the claims to the specific embodiments disclosed in the specification and the claims, but should be construed to include all possible embodiments along with the full scope of equivalents to which such claims are entitled. Accordingly, the claims are not limited by the disclosure.

1.-47. (canceled)

48. A method of operating a system in a medical facility, the system including a plurality of antennas and a controller communicatively coupled to the antennas, the method comprising:

selectively transmitting a number of wideband interrogation signals from at least one of the antennas;

determining whether a response to the wideband interrogation signals was received from a transponder that marks an object used in a medical procedure via the at least one of the antennas used to transmit the number of wideband interrogation signals; and

selectively providing wireless communications that encode at least one of information, commands and data with at least one piece of dedicated medical diagnostic, therapeutic or monitoring equipment via the at least one of the antennas used to transmit the interrogation signal and receive the response signal.

49. The method of claim 48 wherein transmitting a number of wideband interrogation signals from at least one of the antennas includes transmitting the wideband interrogation signals from a number of antennas carried by a patient support structure that carries a patient during a medical procedure.

50. The method of claim 49 wherein transmitting a number of wideband interrogation signals from at least one of the antennas includes transmitting the wideband interrogation signals from a handheld antenna that inductively cooperates with the plurality of antennas carried by the patient support structure.

51. The method of claim 49 wherein at least one of the number of antennas is a handheld antenna, and transmitting the wideband interrogation signals includes transmitting the wideband interrogation signals by one of the handheld antenna or the plurality of antennas carried by the patient support structure, and further comprising receiving any response signals to the wideband interrogation signals by the other one of the handheld antenna or the plurality of antennas carried by the patient support structure.

52. The method of claim 48 wherein transmitting a number of wideband interrogation signals from at least one of the antennas includes transmitting the wideband interrogation signals from at least three loop antennas spaced along a longitudinal axis of one of an operating table, a bed, a mattress or a sheet.

53. The method of claim 48 wherein transmitting a number of wideband interrogation signals from at least one of the antennas includes transmitting the wideband interrogation signals from a plurality of antennas carried by a drape that at least partially surrounds a patient support structure that carries a patient during a medical procedure.

54. The method of claim 48 wherein transmitting a number of wideband interrogation signals from at least one of the antennas includes transmitting the wideband interrogation signals from a plurality of antennas carried by a shade that extends from a light fixture positioned relatively above a patient support structure that carries a patient during a medical procedure.

55. The method of claim 48 wherein providing communications that encode at least one of information, commands and data with at least one piece of dedicated medical diagnostic, therapeutic or monitoring equipment via the at least one of the antennas used to transmit the interrogation signal and receive the response signal includes receiving data signals from the at least one piece of dedicated medical diagnostic, therapeutic or monitoring equipment via the at least one of the antennas used to transmit the interrogation signal and receive the response signal, the data signals representing physiological characteristics of the patient measured by the at least one piece of dedicated medical diagnostic, therapeutic or monitoring equipment.

56. The method of claim 48 wherein providing communications that encode at least one of information, commands and data with at least one piece of dedicated medical diagnostic, therapeutic or monitoring equipment via the at least one of the antennas used to transmit the interrogation

signal and receive the response signal includes receiving data signals from the at least one piece of dedicated medical diagnostic, therapeutic or monitoring equipment via the at least one of the antennas used to transmit the interrogation signal and receive the response signal, the data signals representing operational characteristics of the at least one piece of dedicated medical diagnostic, therapeutic or monitoring equipment.

**57.** The method of claim **48** wherein providing communications that encode at least one of information, commands and data with at least one piece of dedicated medical diagnostic, therapeutic or monitoring equipment via the at least one of the antennas used to transmit the interrogation signal and receive the response signal includes transmitting control signals to the at least one piece of dedicated medical diagnostic, therapeutic or monitoring equipment via the at least one of the antennas used to transmit the interrogation signal and receive the response signal, the control signals representing operational instructions to control operation of the at least one piece of dedicated medical diagnostic, therapeutic or monitoring equipment.

**58.** The method of claim **48**, further comprising: transmitting information by the controller to a display to display information related to at least one of the patient or the at least one piece of dedicated medical diagnostic, therapeutic or monitoring equipment.

**59.** The method of claim **48**, further comprising: receiving by the controller user input entered by a user via a user input device; and

transmitting control signals by the controller based on the received user input to the at least one piece of dedicated medical diagnostic, therapeutic or monitoring equipment via at least one of the number of antennas, the control signals representing operational instructions to control operation of the at least one piece of dedicated medical diagnostic, therapeutic or monitoring equipment.

**60.** The method of claim **48**, further comprising: receiving data signals by the controller via at least one of the antennas from a first one of the at least one piece of dedicated medical diagnostic, therapeutic or monitoring equipment; and

transmitting the received data signals to a second one of the at least one piece of dedicated medical diagnostic, therapeutic or monitoring equipment.

**61.** The method of claim **60** wherein receiving data signals by the controller via at least one of the antennas from a first one of the at least one piece of dedicated medical diagnostic, therapeutic or monitoring equipment includes receiving data signals from a transducer coupled to the patient and transmitting the received data signals to a second one of the at least one piece of dedicated medical diagnostic, therapeutic or monitoring equipment includes transmitting the data signals to a dedicated control system for the transducer.

**62.** The method of claim **60** wherein receiving data signals by the controller via at least one of the antennas from a first one of the at least one piece of dedicated medical diagnostic, therapeutic or monitoring equipment includes receiving data signals from one of an electrocardiogram electrode, a pulse oximetry transducer and transmitting the received data signals to a second one of the at least one piece of dedicated medical diagnostic, therapeutic or monitoring equipment includes transmitting the data signals to one of a dedicated electrocardiogram processing system or a pulse oximetry processing system.

**63.** The method of claim **48** wherein at least one of the antennas is responsive to a force exerted thereon and further comprising:

receiving signals by the controller indicative of the force exerted on the antenna; and

producing a notification if the force exceeds at least one of an amplitude threshold or a time duration.

\* \* \* \* \*

专利名称(译)	检测应答器标记对象并与医疗遥测设备通信的方法和设备，例如在医疗过程期间		
公开(公告)号	<a href="#">US20180039753A1</a>	公开(公告)日	2018-02-08
申请号	US15/786001	申请日	2017-10-17
[标]申请(专利权)人(译)	柯惠有限合伙公司		
申请(专利权)人(译)	COVIDIEN LP		
当前申请(专利权)人(译)	COVIDIEN LP		
[标]发明人	BLAIR WILLIAM A BARNES BRUCE E POIRIER DAVID A		
发明人	BLAIR, WILLIAM A. BARNES, BRUCE E. POIRIER, DAVID A.		
IPC分类号	G06F19/00 A61B5/1455 A61B5/03 A61B5/00 A61B90/98		
CPC分类号	G06F19/3418 A61B5/0002 A61B5/6887 A61B90/98 A61B5/031 A61B5/14551 A61B2017/00212 A61B2017/00221 A61B2562/0247 A61B2562/0261 A61B5/0006 A61B5/704 A61B90/90 A61B90/94 A61B90/96 A61B2560/0271 A61B2562/046 A61B2562/17 G16H40/67		
优先权	61/242699 2009-09-15 US 61/222847 2009-07-02 US		
外部链接	<a href="#">Espacenet</a> <a href="#">USPTO</a>		

摘要(译)

标记有转发器的物体的存在或不存在可以在其中通过询问和检测系统执行医疗程序的环境中确定，该询问和检测系统包括控制器和沿患者支撑结构定位的多个天线。天线可以沿手术台，床，床垫或垫，片定位，或者可以定位在盖布或阴影上。可以连续激活各个天线以发送询问信号。可以监视多个天线以获得从转发器到询问信号的响应。例如，可以监视除了发送最近询问信号的天线之外的所有天线。天线可以响应于力，指示产生这种力的信号。无线生理状况监测器可以检测患者的生理状况并且无线地发送指示这种情况的信号。

