



(19) **United States**  
(12) **Patent Application Publication**  
**Bruinsma et al.**

(10) **Pub. No.: US 2016/0166188 A1**  
(43) **Pub. Date: Jun. 16, 2016**

(54) **EMITTER DRIVER FOR NONINVASIVE PATIENT MONITOR**

(60) Provisional application No. 61/239,741, filed on Sep. 3, 2009.

(71) Applicant: **CERCACOR LABORATORIES, INC.**, Irvine, CA (US)

**Publication Classification**

(72) Inventors: **Johannes Bruinsma**, Opeinde (NL);  
**Cristiano Dalvi**, Lake Forest, CA (US);  
**Marcelo Lamego**, Cupertino, CA (US)

(51) **Int. Cl.**  
**A61B 5/1455** (2006.01)  
**A61B 5/00** (2006.01)

(21) Appl. No.: **14/942,185**

(52) **U.S. Cl.**  
CPC ..... **A61B 5/1452** (2013.01); **A61B 5/6826** (2013.01)

(22) Filed: **Nov. 16, 2015**

(57) **ABSTRACT**

**Related U.S. Application Data**

(63) Continuation of application No. 14/227,230, filed on Mar. 27, 2014, now Pat. No. 9,186,102, which is a continuation of application No. 12/875,062, filed on Sep. 2, 2010, now Pat. No. 8,688,183.

Embodiments of the present disclosure include an emitter driver configured to be capable of addressing substantially  $2^N$  nodes with N cable conductors configured to carry activation instructions from a processor. In an embodiment, an address controller outputs an activation instruction to a latch decoder configured to supply switch controls to activate particular LEDs of a light source.

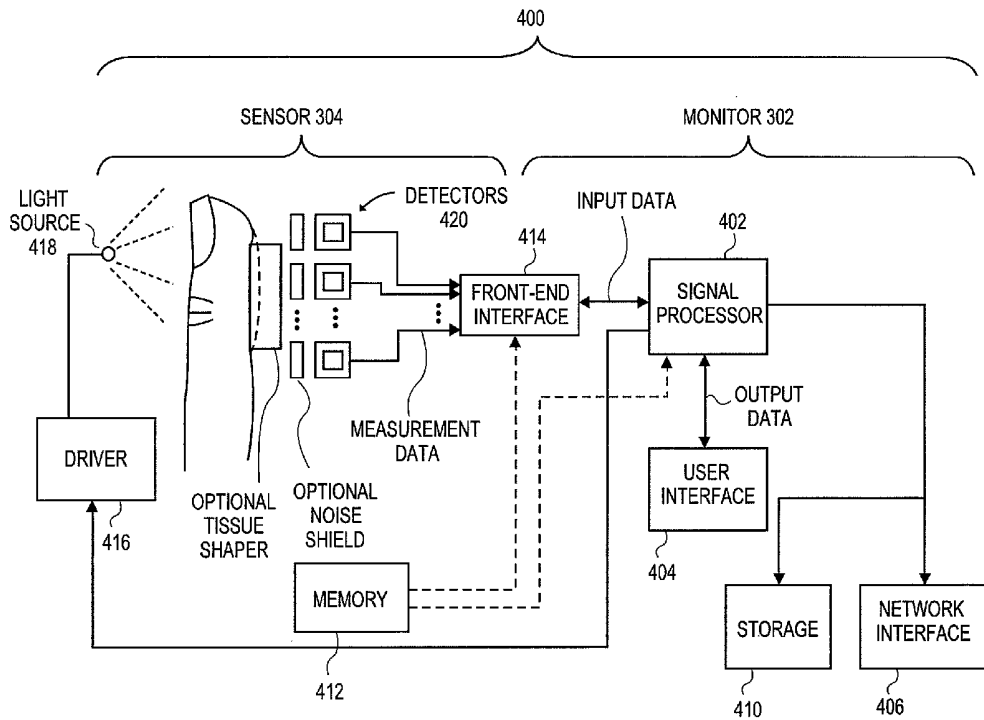

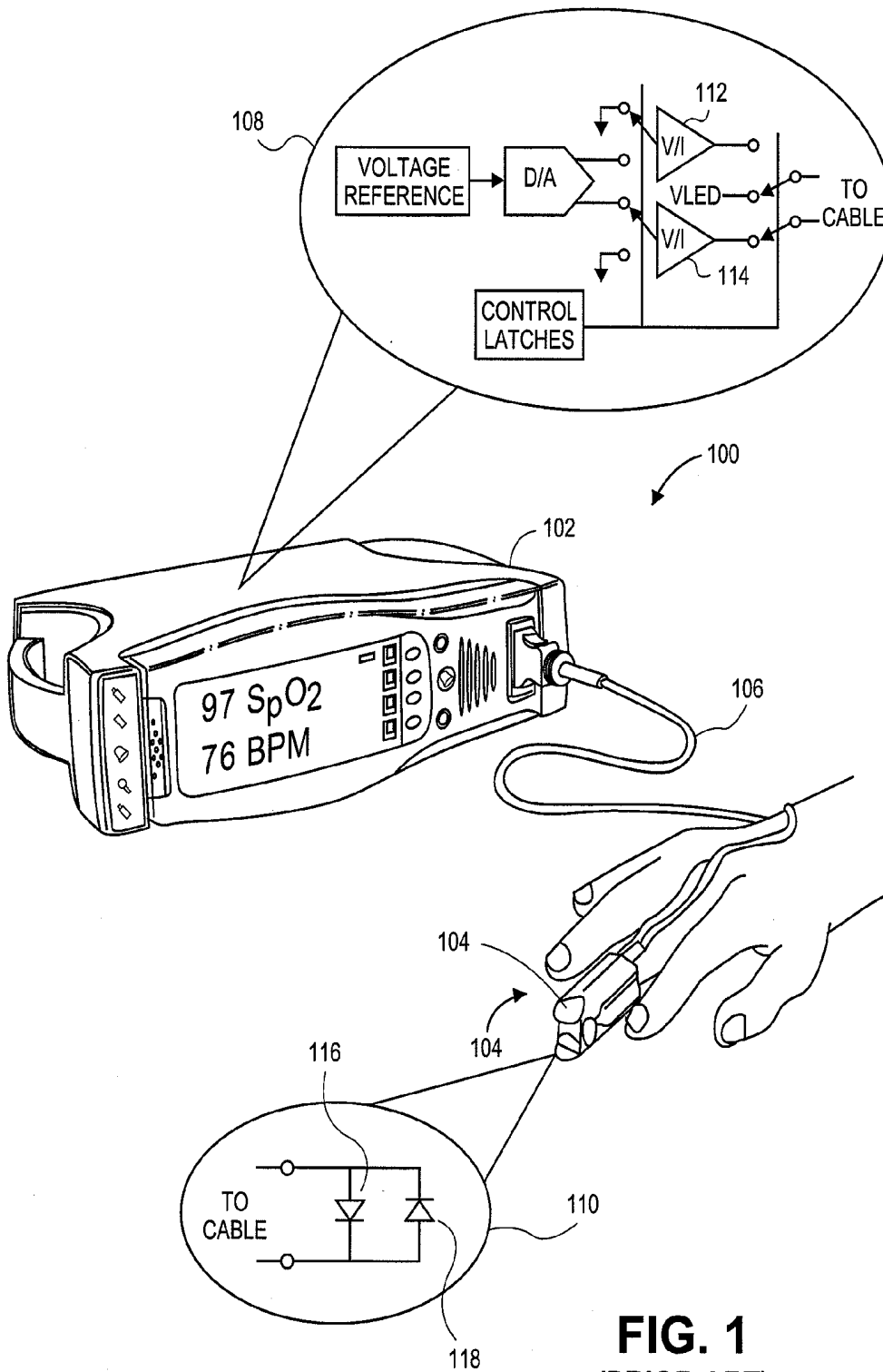

**FIG. 1**  
(PRIOR ART)

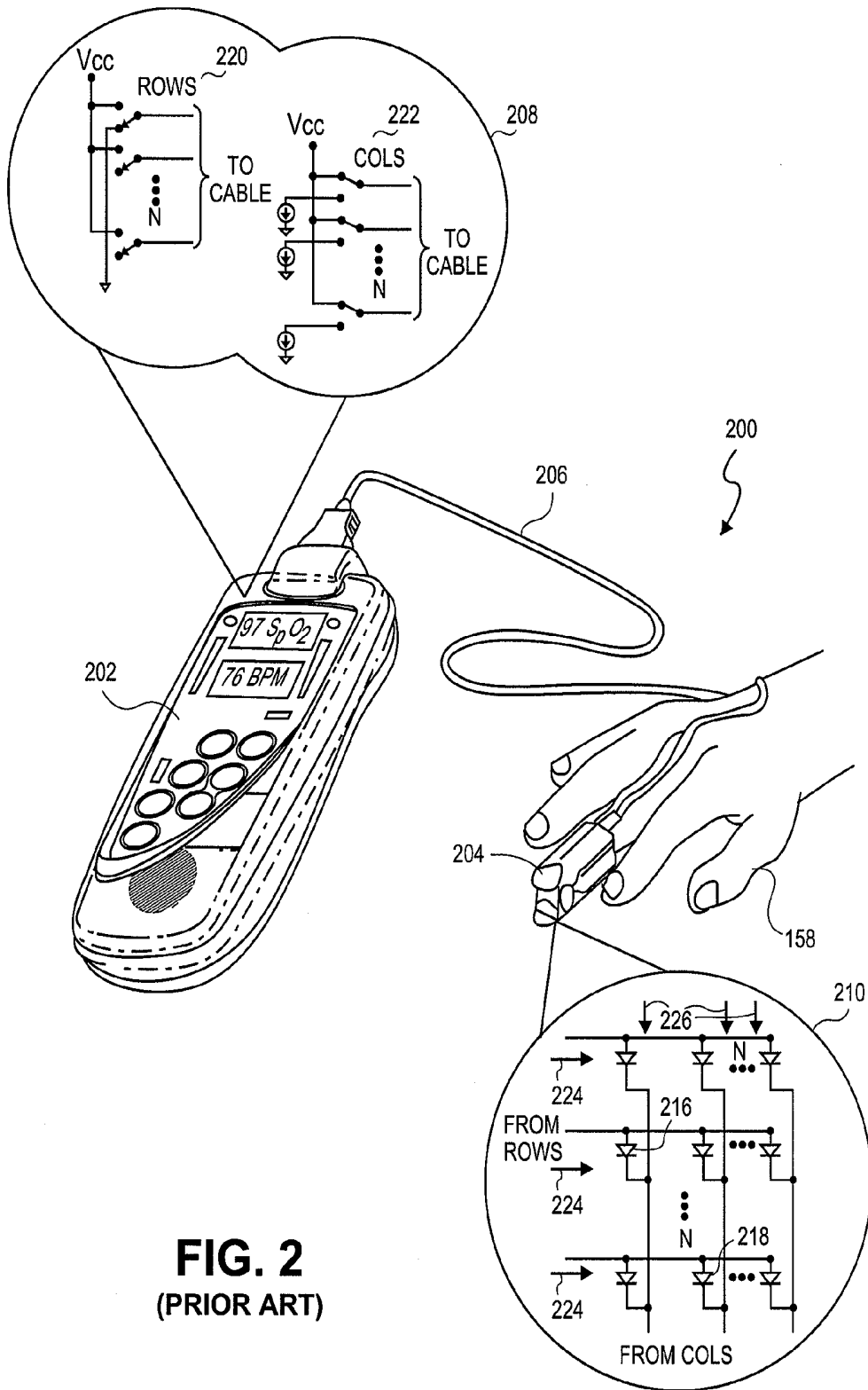

**FIG. 2**  
(PRIOR ART)

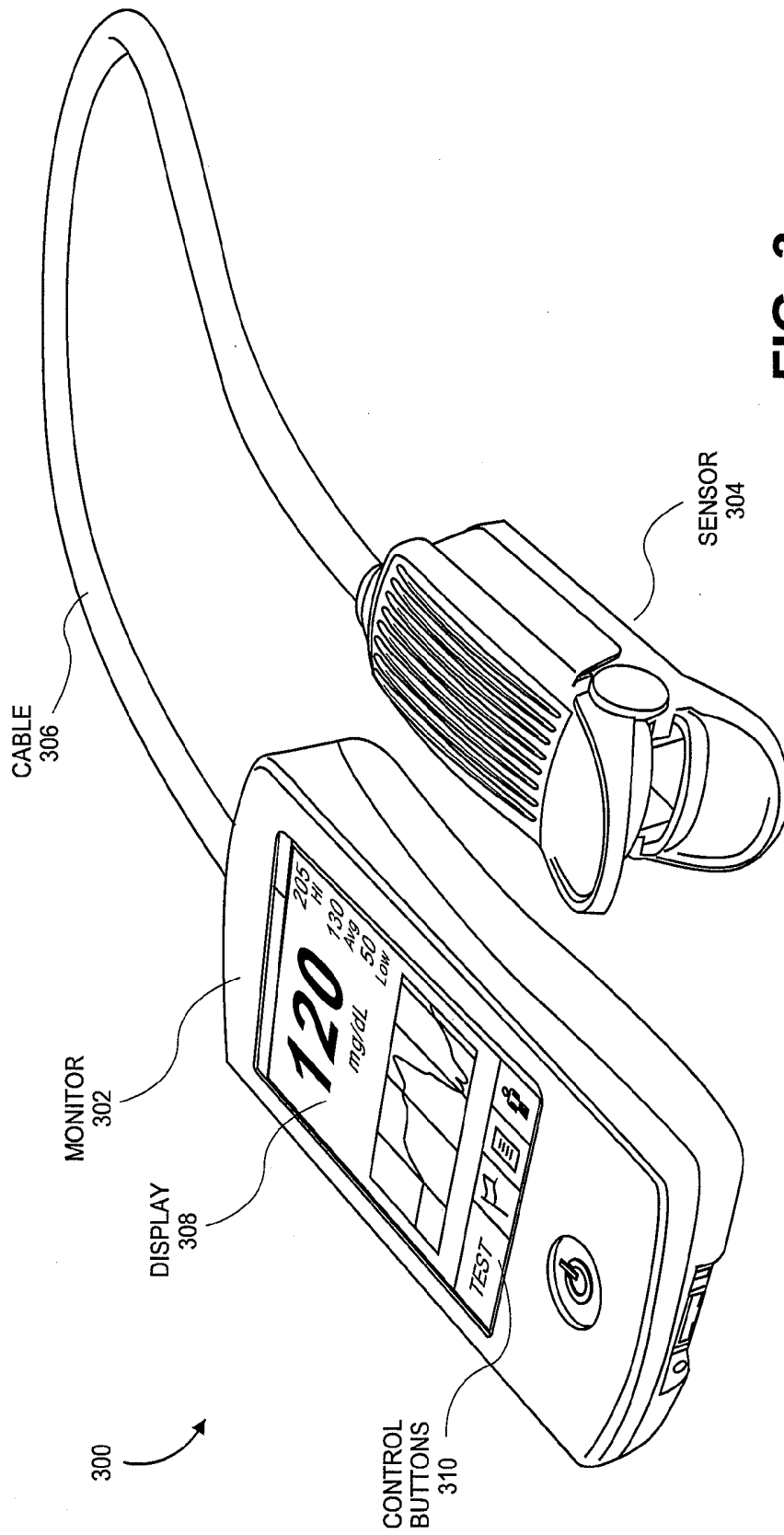

FIG. 3



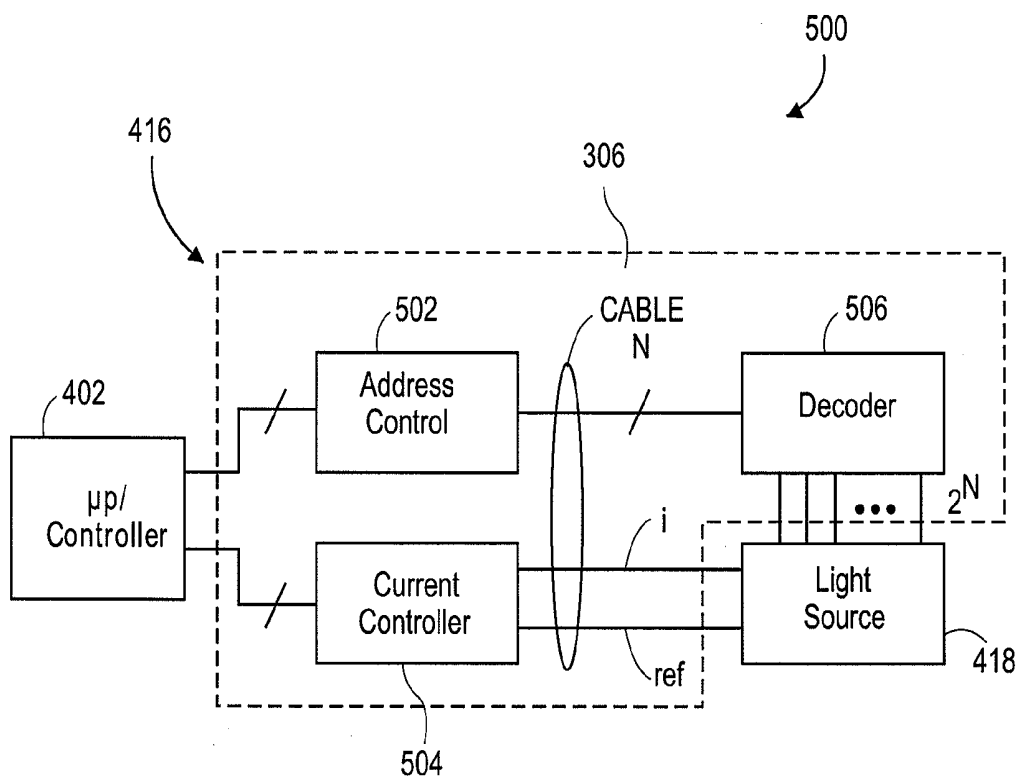
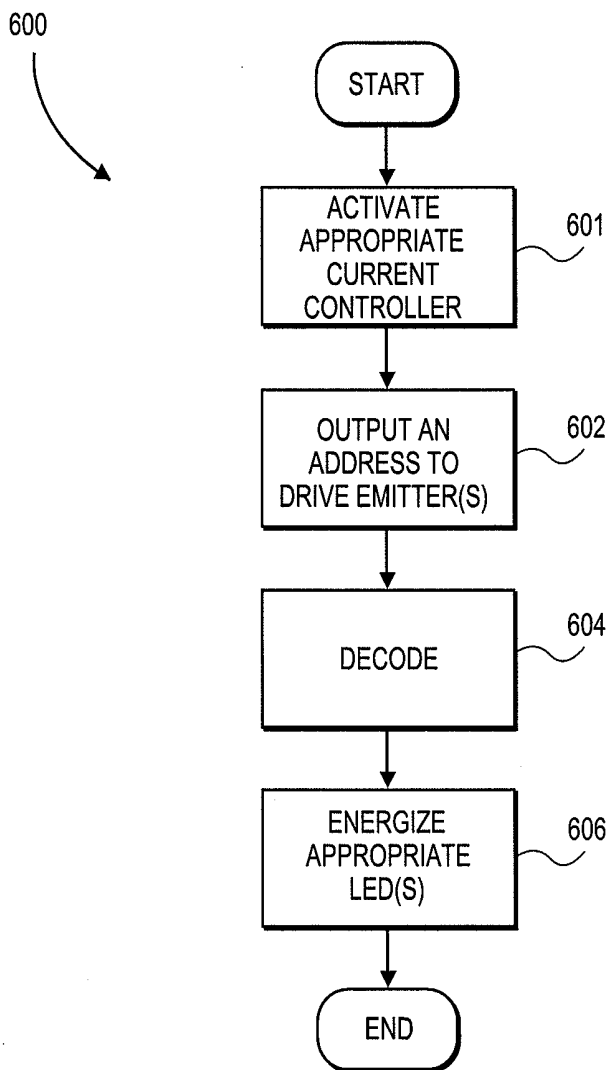

FIG. 5



**FIG. 6**



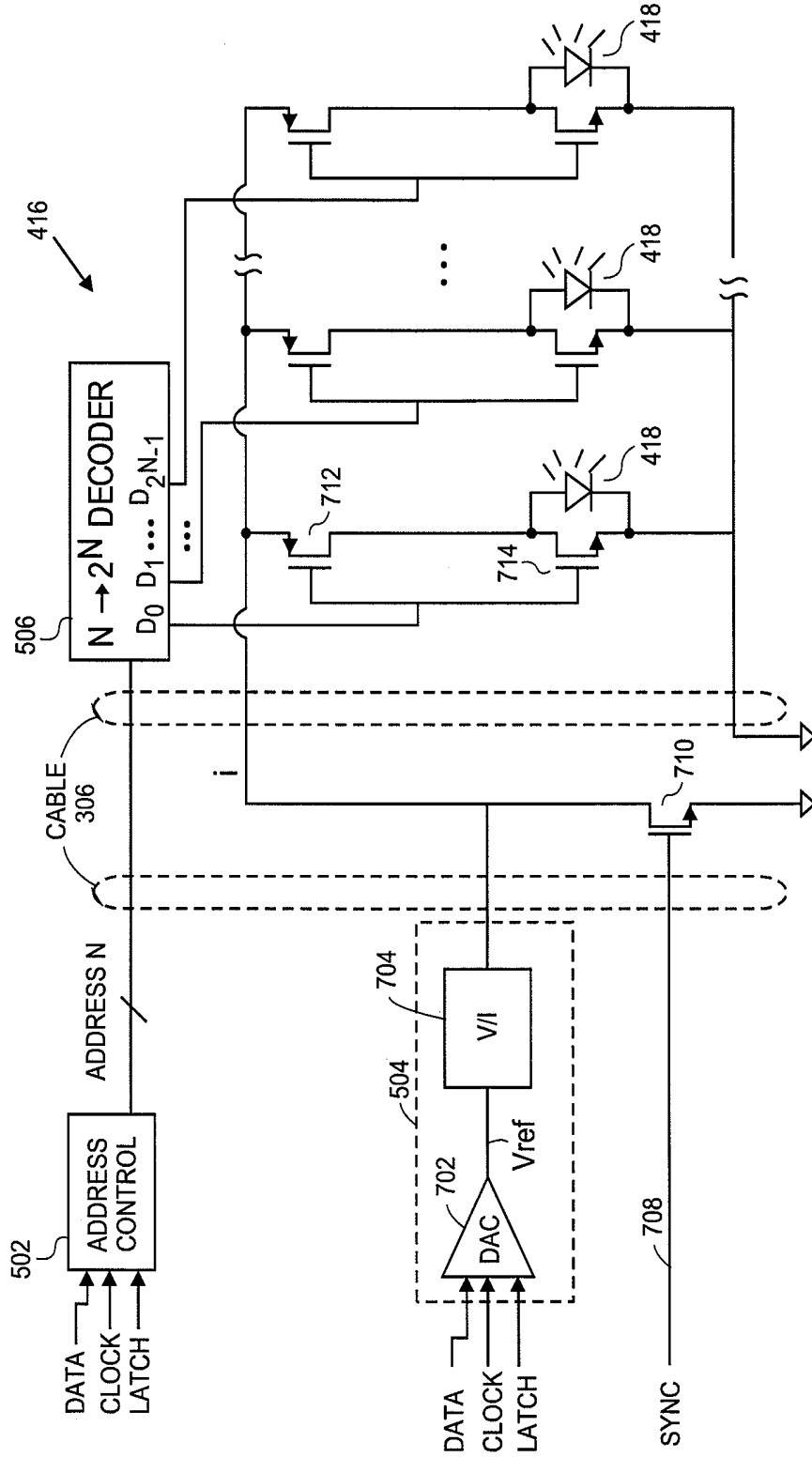

FIG. 7B

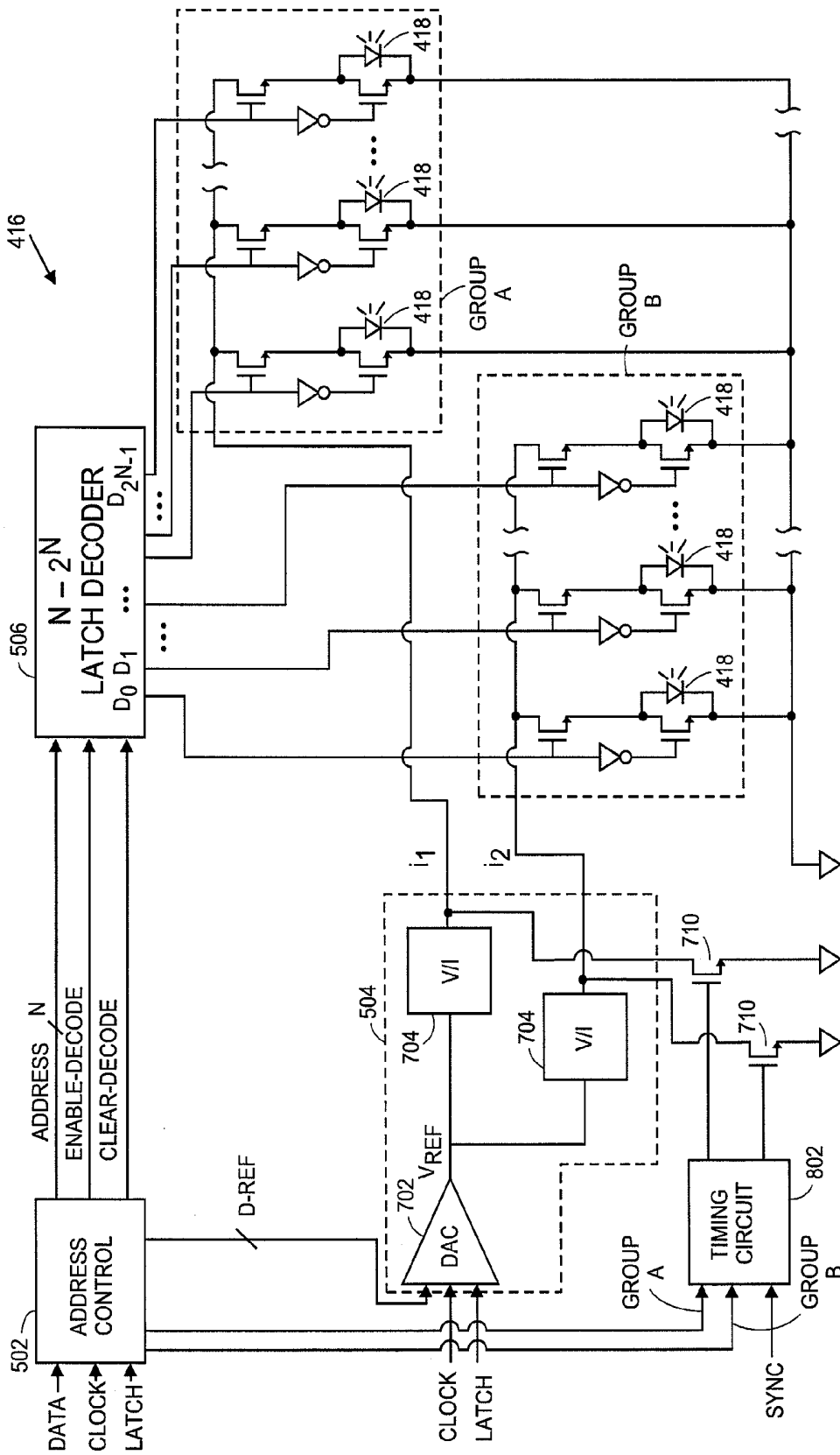

FIG. 8

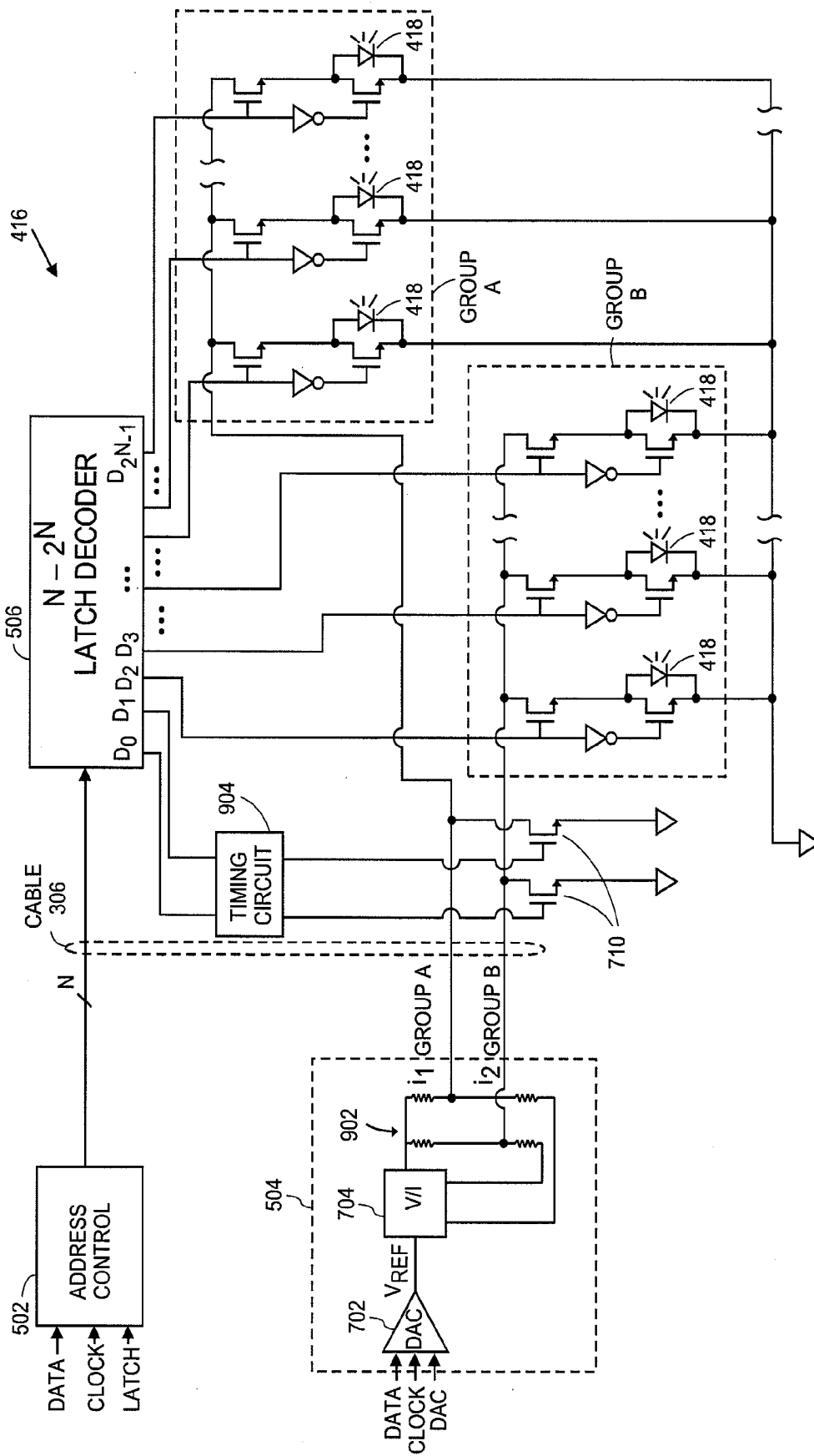

FIG. 9

## EMITTER DRIVER FOR NONINVASIVE PATIENT MONITOR

### REFERENCE TO RELATED APPLICATIONS

**[0001]** The present application is a continuation of U.S. patent application Ser. No. 14/227,230, filed Mar. 27, 2014, entitled “*Emitter Driver for Noninvasive Patient Monitor*,” which is a continuation of U.S. patent application Ser. No. 12/875,062, filed Sep. 2, 2010, entitled “*Emitter Driver for Noninvasive Patient Monitor*,” which claims priority benefit under 35 U.S.C. §119(e) from U.S. Provisional Application No. 61/239,741, filed Sep. 3, 2009, entitled “*Emitter Driver for Noninvasive Patient Monitor*,” the disclosures of which are incorporated herein by reference.

**[0002]** The present disclosure is also related to the following applications.

App. No.	Filing Date	Title	Attorney Docket
12/534,827	Aug. 3, 2009	<i>Multi-Stream Data Collection System for Noninvasive Measurement of Blood Constituents</i>	MASCER.002A
12/534,812	Aug. 3, 2009	<i>Multi-Stream Sensor Front Ends for Noninvasive Measurement of Blood Constituents</i>	MASCER.003A
12/534,823	Aug. 3, 2009	<i>Multi-Stream Sensor for Noninvasive Measurement of Blood Constituents</i>	MASCER.004A
12/534,825	Aug. 3, 2009	<i>Multi-Stream Emitter for Noninvasive Measurement of Blood Constituents</i>	CERCA.005A
12/497,528	Jul. 2, 2009	<i>Noise Shielding for a Noninvasive Device</i>	MASCER.006A
12/497,523	Jul. 2, 2009	<i>Contoured Protrusion for Improving Spectroscopic Measurement of Blood Constituents</i>	MASCER.007A
29/323,409	Aug. 25, 2008	<i>Patient Monitoring Sensor</i>	MASCER.009DA
29/323,408	Aug. 25, 2008	<i>Patient Monitor</i>	MASCER.010DA
12/497,506	Jul. 2, 2009	<i>Heat Sink for Noninvasive Medical Sensor</i>	MASCER.011A

**[0003]** Each of the foregoing is incorporated by reference herein in its entirety.

### BACKGROUND OF THE INVENTION

**[0004]** 1. Field of the Invention

**[0005]** The present disclosure generally relates to patient monitoring devices and more specifically, embodiments of the present disclosure relate to driving light sources of patient monitoring devices to properly irradiate tissue under observation.

**[0006]** 2. Description of the Related Art

**[0007]** Spectroscopic patient monitoring systems including noninvasive patient monitoring systems often energize a plurality of emission devices that irradiate tissue under observation. In many systems, the emission devices irradiate the tissue at different wavelengths at different times. The radiation is scattered and absorbed by the tissue such that some attenuated amount thereof emerges and is generally detected

through one or more photodetectors. The photodetectors output one or more signals indicative of the intensity of the detected attenuated radiation and forward the signal to a patient monitor for processing.

**[0008]** In many systems, the patient monitor provides a drive signal configured to activate each emission device at a different time over an activation cycle, thereby reducing a likelihood that a detector seeking a measure of attenuation in light of one wavelength will be effected by radiation from light of another wavelength.

**[0009]** For example, FIG. 1 illustrates a patient monitoring system **100** including a patient monitor **102** communicating with a noninvasive optical sensor **104** through cable **106**. As shown in FIG. 1, the monitor **102** displays calculated measurements derived at least in part from processing an output signal from the sensor **104** indicative of light attenuated by pulsing blood. As shown in FIG. 1, the monitor **102** includes a driving circuit **108** configured to drive a sensor light source **110**, such as, for example, a two emitter light source configured to emit light at different wavelengths. The emitters shown in FIG. 1 are connected in parallel in a back-to-back configuration, although other configurations and their drive circuitry requirements will be recognizable to an artisan from the disclosure herein, including, for example, common anode, common cathode and the like.

**[0010]** In general, a processor of said monitor **102** controls various latching mechanisms to activate one of voltage-to-current converters **112**, **114** at a time. Once activated, the converters **112**, **114** provide a current through conductors of the cable **106** to an associated LED **116**, **118** of the sensor **104**. Thus, the processor may output appropriate latching signals to the driving circuit **108** to precisely control a duty cycle and current level for each of the LEDs **116**, **118**, and ensure that the LEDs **116**, **118** are activated one at a time. Examples of the driver circuitry of FIG. 1 are disclosed in U.S. Pat. No. 6,157,850. The '850 patent disclosure is incorporated in its entirety by reference herein.

**[0011]** In contrast to the driving circuit **108** and light source **110** of FIG. 1, FIG. 2 illustrates a patient monitoring system **200** including a patient monitor **202** communicating with a noninvasive optical sensor **204** through a cable **206**. As shown in FIG. 2, the monitor **202** displays calculated measurements derived at least in part from processing an output signal from the sensor **204** indicative of light attenuated by pulsing blood. As shown in FIG. 2, the monitor **202** includes a driving circuit **208** configured to drive a sensor light source **210**, such as, a grid array of LEDs capable of emitting light at different wavelengths of radiation.

**[0012]** In general, the driving circuit **208** includes a plurality of row drivers **220** and a plurality of column drivers **222**, the activation of a particular row driver and a particular column driver corresponds to the activation of one or a group of LEDs arranged at a corresponding node in a grid of rows **224** and columns **226**. Such activation is controlled through one or more processors of said monitor **202** in order to precisely control a duty cycle for each of the LEDs in the grid array, including LEDs **216**, **218**. For example, row and column drivers **220**, **222** function together as switches to Vcc and current sinks, respectively, to activate LEDs and function as switches to ground and Vcc, respectively, to deactivate LEDs. This push-pull drive configuration advantageously prevents parasitic current flow, and thus, parasitic activation, in deactivated LEDs. In a particular embodiment, one row drive line **224** is switched to Vcc at a time. Examples of the driver

circuitry of FIG. 2 are disclosed in U.S. Pat. App. Pub. No. 2006/0241363. The '363 patent application's disclosure is incorporated by reference in its entirety herein.

#### SUMMARY OF THE INVENTION

[0013] The foregoing LED driver circuits **108**, **208** include some limitations. The driver circuit **108** uses a separate drive conductor for each LED of the light source **110**. Thus, in the system **100** of FIG. 1, the cable **106** carries N drive currents over N conductors to drive N LEDs. As will be recognizable to an artisan from the disclosure herein, increasing a number LEDs in the light source **110** to, for example, increase a number of available wavelengths, corresponds to increasing a number of conductors in the cable **106**. Each increase of conductors carrying high emitter driver currents in the cable increases a likelihood of interference with other conductors of cable **106**, such as those conductors communicating sensitive very low currents or voltages at high impedance as output signals from the detectors of the sensor **104**. Moreover, each increase of conductors increases cable size, cost, complexity, shielding, cable stiffness, and the like, thereby decreasing patient comfort.

[0014] Driver circuit **208**, including the row and column drivers **220**, **222**, is an improvement to the N-to-N driver circuit **108** of FIG. 1. For example, in the system **200** of FIG. 2, the cable **206** carries N high emitter driver currents on N conductors. Half of the N conductors correspond to high current row drive signals and half correspond to high current column drive signals. These N conductors allow a processor to address and thus activate specific nodes of a light source grid array of  $2^N$  nodes. Similar to the N-to-N driver circuit **108**, an artisan will recognize from the disclosure herein, that increasing a number LEDs in the light source grid array **210** to, for example, increase a number of available wavelengths, corresponds to increasing a number of conductors in the cable **206**, thereby potentially increasing a likelihood of harmful interference in detector signals.

[0015] Based on at least the foregoing, when a need exists to increase a number of different wavelength LEDs to accommodate more sophisticated signal processing of patient monitors, a need exists to find better solutions for driving light sources. Often, increasing available wavelengths corresponds to seeking to measure physiological parameters that are more difficult to distinguish from surrounding noise, including, for example, total hemoglobin monitors, glucose monitors, methemoglobin monitors, combinations of the same or the like, or corresponds to increasing the sensitivity in conventional pulse oximeters. However, simply increasing a number of high current conductors in a given cable **106**, **206** can be fraught with drawbacks including cable stiffness and crosstalk noise on detector conductors.

[0016] Accordingly, embodiments of the present disclosure include a patient monitoring system where a patient monitor employs addressing schemes to increase a number of specifically selectable activation nodes of a light source. In an embodiment, an emitter driver is configured to address substantially  $2^N$  nodes, where N is a number cable conductors configured to carry activation instructions from a processor. In an embodiment, an address controller outputs an activation instruction to a latch decoder configured to supply switch controls to logic devices governing the activations of LEDs of a light source. In an embodiment, N cable conductors can be used to uniquely address all or substantially all of  $2^N$  LED nodes. In certain embodiments, the activation instruction

need not be a high current signal. For example, in some of the presently disclosed embodiments, a cable carries one or a few high current emitter driver signals, which can be routed through logic and addressing to a desired node of the light source. For example, in an embodiment where each LED of a light source can be driven with the same or similar current, embodiments of the cable of the present disclosure may carry a single high current conductor. In embodiments where LEDs of a light source may use different currents to drive different types of LEDs, such as, for example, light sources including superluminescent, laser or side emitting LEDs, along with more traditional LEDs, embodiments of the cable of the present disclosure may carry currents appropriate for each type of LED over a plurality of high current conductors. In many embodiments, however, the number of high current conductors is dramatically reduced from that of the drivers disclosed in the Background herein.

[0017] Embodiments of the present disclosure include a non-invasive physiological sensor configured to output one or more signals indicative of one or more physiological conditions of a patient being monitored. The sensor includes a plurality of light emitting sources configured for transmitting optical radiation to a measurement site. The sensor also includes one or more detectors configured to output said one or more signals responsive to said optical radiation detected after attenuation by body tissue of said patient at said measurement site. The one or more signals are indicative of said one or more physiological conditions of said patient. The sensor also includes a plurality of switches configured for selectively connecting one or more of the light emitting sources to one or more drive signals. Additionally, the sensor includes a decoder circuit configured for controlling the plurality of switches, wherein when said decoder circuit receives N inputs, said decoder circuit configured to selectively address up to  $2^N$  unique locations. Each location includes one or more of said plurality of said semiconductor switches, wherein activation of one of said unique locations causes at least one of said light emitting sources to transmit said optical radiation to said measurement site.

[0018] Embodiments of the disclosure also include a cable communicating signals between a patient monitor and a non-invasive optical sensor. The cable comprises one or more signal lines configured to carry one or more drive signals configured to activate one or more light sources of said non-invasive optical sensor. The cable also includes N address lines capable of selecting  $2^N$  unique locations and configured to selectively connect up to about  $2^N$  light emitting sources to ones of said one or more drive signals. The connection activating said light emitting sources to provide light to tissue of a patient wearing said sensor and allowing one or more photodetectors to detect light from said activated sources after attenuation by tissue from said patient.

[0019] In still other embodiments, the disclosure includes a method to selectively drive light emitting sources in a non-invasive optical physiological sensor for monitoring parameters of a patient. The method includes attaching said sensor to a patient where said sensor includes at least one different semiconductor switch in series with each of the light emitting sources. The method also including activating said semiconductor switches to connect associated light emitting sources to a drive signal. The light emitting source transmits optical radiation into a measurement site of said patient, and said activation comprises providing N conductors to a decoder

capable of controlling about  $2^N$  of the semiconductor switches and configured to control up to about  $2^N$  of the semiconductor switches.

[0020] For purposes of summarizing the invention, certain aspects, advantages and novel features of the invention have been described herein. Of course, it is to be understood that not necessarily all such aspects, advantages or features will be embodied in any particular embodiment of the invention.

#### BRIEF DESCRIPTION OF THE DRAWINGS

[0021] The following drawings and the associated descriptions are provided to illustrate embodiments of the present disclosure and do not limit the scope of the claims.

[0022] FIG. 1 illustrates a traditional patient monitoring system including a patient monitor communicating with a noninvasive optical sensor through a cable.

[0023] FIG. 2 illustrates another traditional patient monitoring system including a patient monitor communicating with a noninvasive optical sensor through a cable.

[0024] FIG. 3 illustrates a patient monitoring system according to embodiments of the present disclosure.

[0025] FIG. 4 illustrates an exemplary block diagram of embodiments of the system of FIG. 3.

[0026] FIG. 5 illustrates an exemplary block diagram of embodiments of a driver of FIG. 4.

[0027] FIG. 6 illustrates an exemplary flowchart of a driving process according to embodiments of the present disclosure.

[0028] FIGS. 7A-7B illustrates exemplary block diagrams of alternative embodiments of the driver of FIG. 4, where FIG. 7A illustrates a first method of shorting unused LEDs and FIG. 7B illustrates a second method of shorting unused LEDs.

[0029] FIG. 8 illustrates another exemplary block diagram of an embodiment of the driver of FIG. 4 configured to drive LEDs with different drive current requirements.

[0030] FIG. 9 illustrates another exemplary block diagram of an embodiment of the driver of FIG. 4 configured to drive LEDs while avoiding a SYNC signal through a patient cable.

#### DETAILED DESCRIPTION OF THE PREFERRED EMBODIMENT

[0031] Embodiments of the present disclosure include a patient monitoring system including a patient monitor having a driving circuit advantageously capable of selectively activating  $2^N$  LEDs of a light source using a decoder receiving an N signal address. In various disclosed embodiments, use of addressing and a decoder advantageously reduces a number of high current conductors in a cable communicating signals between the monitor and, for example, a noninvasive sensor. For example, in embodiments where a light source includes LEDs configured to be driven by a single current, embodiments of the present disclosure provide that the cable may carry a single high current conductor. In other embodiments where the light source includes LEDs configured to be driven at a first current and additional LEDs configured to be driven at a second current different from the first, embodiments of the present disclosure provide that the cable may carry the plurality of high current conductors, one for each current required. While some embodiments shown herein require two currents, an artisan will recognize from the disclosure herein how to add additional currents when LED configurations so require.

[0032] In the foregoing embodiments, the driver circuit advantageously includes use of addressing and a decoder, the addressing information carried over conductors carrying lower, less interfering signals than those of driving currents. Accordingly, embodiments of the present disclosure reduce the potential of harmful crosstalk between high current conductors carrying driver signals and low current conductors carrying, for example, sensitive detector signals. Moreover, cables associated with the present disclosure may advantageously require fewer larger heavily shielded driver conductors, and therefore, may be less costly to produce, be less rigid or stiff and thus more ergonomic to a wearer of a sensor.

[0033] In additional embodiments, each LED is shorted by a transistor that is conducting unless that particular LED is activated. Such shorting advantageously reduces the likelihood of unwanted emissions by LEDs emitting unwanted wavelengths due to, for example, parasitic currents. Also, various embodiments include on/off timing hardware configured to govern the shorting transistors to improve timing of LED activations and deactivations.

[0034] To facilitate a complete understanding of the invention, the remainder of the detailed description references to the drawings, wherein like reference numbers are referenced with like numerals throughout.

[0035] FIG. 3 illustrates a patient monitoring system 300 according to embodiments of the present disclosure. As shown in FIG. 3, the system 300 includes a patient monitor 302, a noninvasive sensor 304 communicating with the monitor 302 through a cable 306. The monitor 302 drives a lights source including a plurality of emitters of the sensor 304 to irradiate tissue of a wearer of the sensor 304. The sensor 304 also includes one or more photodetectors that detect light attenuated by the body tissue and output one or more signals indicative of the detected light. The monitor 302 receives the one or more output signals of the sensor 304, processes the signals and determines one or more measurement values of various physiological characteristics of the wearer. The monitor 302 includes a display 308 configured to provide alphanumeric and/or graphical information to a caregiver. The monitor 302 also includes a plurality of user input devices 310 including for example, a touch screen and one or more input keys. An artisan will recognize from the disclosure herein that the input devices 310 could comprise one or a combination of control buttons, dials, knobs, or the like, touch screen inputs, vocal commands, or the like.

[0036] Although disclosed as a portable handheld device, an artisan will recognize from the disclosure herein that the monitor 302 may comprise a desktop or stationary monitor, may monitor some or many parameters, may output information to legacy caregiver systems, may wirelessly communicate between sensors and monitors, between monitors and other monitors, combinations of the same and the like.

[0037] FIG. 4 illustrates an exemplary block diagram 400 of embodiments of the monitor 302 of the system of FIG. 3. As shown in FIG. 4, the monitor 302 may include one or more signal processors 402 communicating with a user interface 404, network interface 406, memory and storage 410, sensor and/or cable memory 412, a front end interface 414 and driver circuitry 416. In general, the processor 402 outputs control data to the driver circuitry 416, which in turn selectively activates LEDs of a light source 418 to irradiate tissue, such as, for example a digit of the wearer. The tissue absorbs the irradiation and one or more detectors 420 detect the attenuated light. The detectors output one or more signals indicative

of the attenuated light to the front end interface **414**, which filters and pre-process the output signal. Signal processor **402** receives the processed and filtered output signal and determines measurement values for the one or more monitored parameters.

[0038] In various embodiments, the sensor **304** may include a tissue shaper configured to mechanically stabilize and/or control the shape of the digit at the measurement site. In an embodiment, the tissue shaper may advantageously include a bump including a substantially cylindrical surface. Additional embodiments of the tissue shaper are disclosed in U.S. patent application Ser. No. 12/534,827, filed on Aug. 3, 2009. The teachings of the '827 application relating to the tissue shaper are incorporated by reference in its entirety herein. Additionally, advantages are found in the spatial arrangement of the detectors, the number of detectors **420** and in noise shielding structures of the sensor **304**. Disclosures pertaining thereto can also be found in the '827 application, and those disclosures are also incorporated by reference in their entirety herein.

[0039] In addition to the foregoing, the processor **402** is also configured to execute measurement determination software instructions that use received detector signal data pre-processed by the front end **414** to determine output measurement values for one or more parameters of the tissue. Exemplary algorithms for determining measurement values can be found in U.S. Pat. No. 6,157,850, U.S. patent application Ser. No. 12/534,827, filed on Aug. 3, 2009 and Ser. No. 11/366,209, filed on Mar. 1, 2006. The disclosure relating to determination of measurements from input sensor data is incorporated from each of the foregoing documents in its entirety by reference herein.

[0040] FIG. 5 illustrates an exemplary block diagram **500** of embodiments of the driver **416** of FIG. 4. As shown in FIG. 5, the processor **402** communicates with an address control **502** and one or more driving current controllers **504** to precisely control activation of the light source **418**. In an embodiment, the address control **502** outputs an address, such as, for example, a binary number, to a decoder **506**. The decoder **506** decodes the address and identifies particular LED(s) of the light source **418** to be connected to the current source **504**. Once connected, current flows through the particular LED, thereby activating it to irradiate tissue. In an embodiment, the decoder comprises an N-to- $2^N$  decoder, which an artisan will recognize from the disclosure herein to include its broad ordinary meaning, including a decoder that accepts an address word, such as, for example, a binary set of N bits, and associates that word with a particular LED node. For example, a 4 bit word uniquely identifies 16 possible LEDs. However, extension of just an additional 4 bits to an 8 bit word uniquely identifies up to 256 possible LEDs or LED locations. Examples of the decoder **506** are commercially available from vendors such as Fairchild Semiconductor, Texas Instruments, NXP Semiconductors, or the like.

[0041] In an embodiment, the current controller **504** may comprise logic allowing the processor **402** the ability to select from a plurality of differing currents levels. For example, when the light source **418** comprises, for example, LED devices and more powerful superluminescent, laser or side emitting LEDs, the driver **416** adjusts the current controller **504** to provide the appropriate current to the appropriate LED at the appropriate address. For example, the current controller **504** may advantageously select an appropriate one of a plu-

rality of currents depending on a type of LED addressed by the processor **402** through the address decoder **506**.

[0042] In an embodiment, the current controller **504** seeks to keep current patterns similar regardless of whether LEDs are activated or not. In embodiments having a plurality of different currents, twisting the conductors on which the currents travel in opposite direction to the input data wires in the cable **306** has been shown to reduce effects of crosstalk on other conductors in the cable **306**.

[0043] FIG. 5 also shows that the address control **502** and current controller **504** may advantageously be housed in the monitor **302**, although an artisan will recognize from the disclosure herein that one or more of the controls **502**, **504** could reside anywhere along the path from the monitor **302** to the sensor **304**, including the various connectors of the monitor **302**, the cable **306** and the sensor **304**. As shown in FIG. 5, the cable **306** includes conductors for the N address lines, the current sources, ground, shield, and other needs, such as, for example, conductors communicating with a thermister, one or more memories, or other desired sensor devices.

[0044] FIG. 6 illustrates an exemplary flowchart of a driving process **600** according to embodiment of the present disclosure. In block **601**, the processor **402** activates the current controller to output an appropriate current. In an embodiment of multiple current sources, the activation includes a selection of an appropriate current, as will be discussed further with respect to FIGS. 8 and 9. In block **602**, the processor **402** outputs an address of a particular LED to be activated. In block **604**, the N-to- $2^N$  decoder **506** receives the address and determines the unique output to be activated. In an embodiment, the determination includes translation of a binary or other word to activation of logic transistors configured to connect a particular LED to the current source and in some embodiments, disconnect a short around the same LED. In block **606**, the decoder **506** activates the appropriate logic devices to connect the appropriate LED to the appropriate current controller **504** for the duration of the determined duty cycle. In an embodiment, the address control **502** comprises latches set by the processor **402** in order to control for each LED the on and off timing. In an embodiment, one node is energized at a time, and in further embodiments, some time spacing or gap is provided between consecutive activations to guard against interference at the detector by light of differing wavelengths. In an embodiment, the gap, or no LED activation occurs between activations of LEDs. In an embodiment, the gap comprises one of the  $2^N$  addressable locations such that an all-off condition is specifically addressable by the processor **402**. In an embodiment, the addressable all-off condition may comprise multiple addresses, one for each current level available from the current controller **504**.

[0045] Although disclosed with reference to process **600**, an artisan will recognize from the disclosure herein that other processes may be used to selectively address an activation location or group of activation locations of a light source and supply the location or group of activation locations with the appropriate amount of current.

[0046] FIGS. 7A and 7B illustrate exemplary block diagrams of embodiments of the driver **416** driving the light source **418** of FIG. 4, where the driver **416** includes a single current controller. As shown in FIGS. 7A and 7B, the driver **416** includes the address control **502**, the current controller **504**, and the decoder **506**. In an embodiment, the current controller **504** includes a converter **702** converting digital signals from the processor into analog output. In an embodi-

ment, the DAC 702 controls light saturation by allowing for the fine tuning of the output drive current. The DAC 702 receives clock and data signals from the processor and a latching signal dictating when the DAC should lock the data on the data signal and stabilize the output drive current.

[0047] The output of the DAC 702 is provided to amplifier 704 which in an embodiment includes a precision voltage-to-current amplifier that adjusts its output current based on the input voltage. The output of the amplifier 704 is also provided as the driving current to the LEDs of the light source 418, in an embodiment, through the cable 306. A SYNC signal 708 is provided to ensure precision on/off timing to the LED addressed by the decoder 506. Imperfections in the circuitry and parasitic parameters may cause the rise and fall times for the current  $i$  to be less precise than desired. The SYNC signal 708 can advantageously be timed to sink to ground some or all of the imperfections and parasitic parameters that occur during rising or falling current through the LED 418 through a logic switching device 710. Sinking these imperfections advantageously produces a higher quality current, which produces better on/off activation of the light source 418, which provides for a better signal to noise ratio. In an embodiment, the sync signal 708 is combined to create a single output current  $i$ . In an embodiment, the output current may comprise about 0-about 80 mA, controlled at least in part by the voltage provided by the processor 402 to the DAC 702.

[0048] As shown in FIGS. 7A and 7B, control logic ensures that each LED of the light source 418 can activate only when its location is decoded by the decoder 506. For example, when a particular location is inactive, a first logic device 712 is biased open such that current cannot flow through it. A second logic device 714 is biased closed to create a short around the LED at the inactive location; the short is also connected to ground. Thus, were any parasitic current to appear on the drive conductor for the particular location, it will be simply shorted to ground and cannot cause the LED to emit radiation. When the decoder 506 receives the address of the particular location, the first logic device 712 is biased closed and the second logic device 714 is biased open. The closing of device 712 connects the second logic device and the LED of the particular location to the current  $i$  of the current controller 504. The opening of device 714 removes the short around the LED, which is now connected to the drive current  $i$ , and the LED activates to emit light at its designated wavelength.

[0049] In the embodiment shown in FIG. 7A, an inverter 716 is placed at one the gates of the logic devices 712 and 714, causing them to oppose one another. For example, a single control signal from the decoder 504 is supplied to the gate of device 712 causing it to open or close, and its opposite is supplied to the gate of device 714 causing it to respectively close or open. In the embodiment shown in FIG. 7B, devices 712 and 714 are opposite devices such that a same signal from the decoder 504 applied to both gates causes one of the devices 712 to open and close while the other 714 respectively closes and opens.

[0050] An artisan will recognize from the disclosure herein other logic devices and schemes to assist in precisely governing the on/off cycles of each LED of the light source 418 while simultaneously precisely governing the drive current to the same.

[0051] As can also be seen in FIGS. 7A and 7B, the cable 306 carries conductors for the output of the current controller 504 and the address control. In alternative embodiments, the cable 306 may also carry the SYNC signal. Thus, in various

embodiments, the cable 306 may advantageously include a single high current signal,  $N$  address signals and still be able to uniquely activate substantially  $2^N$  light source nodes. In an embodiment, "substantially" may be defined to be when one or more of the  $2^N$  light source nodes correspond to a null set where no nodes are active. The null set is advantageous to ensure spacing between LED activations.

[0052] FIG. 8 illustrates another exemplary block diagram of embodiments of the driver 416 driving the light source 418 of FIG. 4, where the driver 416 comprises a plurality of current controllers 504. As shown in FIG. 8, the current controller 504 outputs two different currents  $i_1$  and  $i_2$  set by the voltage output by the converter 702 governed by the processor 402. FIG. 8 further shows output current  $i_1$  communicating with the nodes of a first group of LEDs, Group A, and the output current  $i_2$  communicating with the nodes of a second group of LEDs, Group B. In an embodiment,  $i_1$  may comprise about 0-about 80 mA, while  $i_2$  may comprise about 0-about 800 mA. An artisan will recognize that other embodiments may advantageously employ other currents and/or have more or less groups.

[0053] Thus, in an embodiment where some of the LEDs of the light source 418 comprise LEDs driven at greater power; those LEDs may advantageously communicate with the output of the current source  $i_2$ . Also shown in FIG. 8 is timing circuit 802 including logic configured to provide appropriate SYNC signals to logic devices 710 for sinking each of currents  $i_1$  and  $i_2$  similar to that disclosed with reference to FIGS. 7A and 7B.

[0054] In an embodiment, the amplifier 704 comprises a plurality of amplifiers and resistors in a feedback configuration to provide a stabilized current based on an input voltage. Such configurations are known to an artisan from the disclosure herein. In an embodiment, the timing circuit 802 comprises logic combinations of signals to ensure only one of the currents  $i_1$  and  $i_2$  can flow to ground at a time. In an embodiment, the SYNC signal is logic ANDed with each of the Group A, Group B signals such that the SYNC and Group A signals must match to open a first logic switch device 710 and allow current  $i_1$  to flow, and SYNC and Group B signals must match to open a second logic switch device 710 and allow current  $i_2$  to flow.

[0055] FIG. 9 illustrates another exemplary block diagram of embodiments of the driver 416 driving the light source 418 of FIG. 4, where the driver 416 comprises a plurality of current controllers 504. However, in FIG. 9, the current controller 504 outputs two different currents  $i_1$  and  $i_2$  using a single amplifier 704 and analog circuitry 902 that produces the currents  $i_1$  and  $i_2$  for Group A and Group B LEDs. Moreover, FIG. 9 illustrates the SYNC signal functionality and the signal itself as part of the sensor 104. For example, in this embodiment, two locations or addresses available on the decoder 505 correspond to the SYNC signals of FIG. 8, such that the processor 402 produces the SYNC signals not as processor outputs, but as addresses of the controller 504. Timing circuit 904 includes logic to ensure only one of the currents  $i_1$  and  $i_2$  can flow to ground at a time by controlling logic device 710 now on the sensor 304. Thus, in the embodiment of FIG. 9, the processor 402 advantageously replaces output signals with addressing. The advantages of this embodiment include the sinking of parasitic currents and imperfections on the LED driver 416 itself, and particularly on the sensor 304, which is downstream from the cable 306. In some cases, the cable 306 produces many of the parasitic

currents and imperfections due to resistance, inductance and capacitance (or the like) associated with the conductors and conductive materials of the cable 306. Sinking these harmful effects downstream on the sensor ensures that they do not effect the operation of the LEDs 418.

[0056] Although the driver circuitry is disclosed with reference to its preferred and alternative embodiments, the disclosure is not intended to be limited thereby. Rather, a skilled artisan will recognize from the disclosure herein a wide number of alternatives for driver, including, for example, employing an amplifier/DAC for each group of current controllers to increase performance thereof. Also, the artisan will recognize from the disclosure herein that the address control, the decoder, and the current controllers can individually be placed anywhere along the monitoring path. For example, the components can be housed in the monitor 302, in the sensor 304, or in the cable 306 or connectors associated with any of the foregoing.

[0057] Additionally, other combinations, omissions, substitutions and modifications will be apparent to the skilled artisan in view of the disclosure herein. Accordingly, the present invention is not intended to be limited by the reaction of the preferred embodiments, but is to be defined by reference to the appended claims.

[0058] Moreover, all publications, patents, and patent applications mentioned in this specification are herein incorporated by reference to the same extent as if each individual publication, patent, or patent application was specifically and individually indicated to be incorporated by reference.

1-15. (canceled)

16. A patient monitor configured to communicate with an optical sensor, the patient monitor comprising:

means for supplying a current to one or more optical radiation sources of an optical sensor;

means for determining an address of  $2^N$  addresses to set a wavelength of optical radiation emitted by the one or more optical radiation sources to a desired wavelength, each of at least some of the  $2^N$  addresses uniquely corresponding to a different wavelength of the optical radiation emitted by the one or more optical radiation sources, N being a number greater than 2; and

means for outputting the address as a set of N bits transmitted separately via N terminals.

17. The patient monitor of claim 16, wherein the means for supplying is configured to:

supply a first current level to the one or more optical radiation sources when the address is a first address; and

supply a second current level to the one or more optical radiation sources when the address is a second address different from the first address, the second current level being different from the first current level.

18. The patient monitor of claim 16, wherein the means for supplying is configured to:

supply a first current level to a first optical radiation source of the one or more optical radiation sources and not to a second optical radiation source of the one or more optical radiation sources; and

supply a second current level to the second optical radiation source and not to the first optical radiation source, the second current level being different from the first current level.

19. The patient monitor of claim 16, further comprising means for receiving a signal from the optical sensor in

response to the means for outputting outputting the address, the signal being indicative of one or more physiological parameters of a patient.

20. The patient monitor of claim 19, further comprising means for determining a measurement value for the one or more physiological parameters based at least on the signal.

21. The patient monitor of claim 20, further comprising means for presenting the measurement value to a caregiver.

22. The patient monitor of claim 21, wherein the measurement value denotes a blood oxygen saturation level.

23. The patient monitor of claim 16, further comprising means for decoding the address and activating the one or more optical radiation sources according to a result of decoding the address.

24. The patient monitor of claim 16, wherein the means for supplying is configured to keep a pattern of the current supplied to the one or more optical radiation sources consistent regardless of whether the optical radiation is being emitted by the one or more optical radiation sources.

25. The patient monitor of claim 16, wherein the means for supplying, the means for determining, and the means for outputting are positioned in a common housing.

26. The patient monitor of claim 16, further comprising means for providing a signal to control a precision of when the optical radiation is emitted by the one or more optical radiation sources.

27. The patient monitor of claim 16, in combination with the optical sensor, the one or more optical radiation sources comprising a plurality of light emitting diodes.

28. The patient monitor of claim 16, wherein N is 4.

29. The patient monitor of claim 16, wherein the means for supplying is configured to supply a current level ranging from 0 mA to 800 mA to the one or more optical radiation sources.

30. A patient monitor configured to communicate with an optical sensor, the patient monitor comprising:

a processor configured to select a desired wavelength of optical radiation emitted by one or more optical radiation sources of an optical sensor;

a current control circuit configured to supply a current to the one or more optical radiation sources; and

an address control circuit configured to set a wavelength of the optical radiation emitted by the one or more optical radiation sources to the desired wavelength by outputting an address as a set of N bits transmitted in parallel via N terminals, the address being selected from an address space comprising a plurality of addresses in which at least some of each of the plurality of addresses uniquely correspond to a different wavelength of the optical radiation emitted by the one or more optical radiation sources, N being a number greater than 2,

wherein a total number of addresses in the plurality of addresses is greater than  $2N$  and less than or equal to  $2^N$ .

31. The patient monitor of claim 30, wherein the current control circuit is configured to:

supply a first current level to the one or more optical radiation sources when the address is a first address;

supply a second current level to the one or more optical radiation sources when the address is a second address different from the first address, the second current level being different from the first current level.

32. The patient monitor of claim 30, wherein the processor is configured to receive a signal from the optical sensor in

response to the address control circuit outputting the address, the signal being indicative of one or more physiological parameters of a patient.

**33.** The patient monitor of claim **32**, wherein the processor is configured to:

determine a measurement value for the one or more physiological parameters based at least on the signal; and output the measurement value for presentation to a caregiver.

**34.** The patient monitor of claim **33**, wherein the measurement value denotes a blood oxygen saturation level.

**35.** The patient monitor of claim **30**, wherein N is 4.

\* \* \* \* \*

专利名称(译)	用于无创患者监护仪的发射器驱动器		
公开(公告)号	<a href="#">US20160166188A1</a>	公开(公告)日	2016-06-16
申请号	US14/942185	申请日	2015-11-16
[标]申请(专利权)人(译)	CERCACOR LAB		
申请(专利权)人(译)	CERCACOR LABORATORIES , INC.		
当前申请(专利权)人(译)	CERCACOR LABORATORIES , INC.		
[标]发明人	BRUINSMA JOHANNES DALVI CRISTIANO LAMEGO MARCELO		
发明人	BRUINSMA, JOHANNES DALVI, CRISTIANO LAMEGO, MARCELO		
IPC分类号	A61B5/1455 A61B5/00		
CPC分类号	A61B5/6826 A61B5/14552 A61B5/0059 A61B2560/045 A61B2562/0233 A61B2562/046 A61B2562/222		
优先权	61/239741 2009-09-03 US		
其他公开文献	US9668680		
外部链接	<a href="#">Espacenet</a> <a href="#">USPTO</a>		

摘要(译)

本公开的实施例包括发射器驱动器，该发射器驱动器被配置为能够寻址具有N个电缆导体的基本上 $2^N$ 节点，N个电缆导体被配置为携带来自处理器的激活指令。在一个实施例中，地址控制器向锁存器解码器输出激活指令，锁存器解码器被配置为提供开关控制以激活光源的特定LED。

