



US 20150305667A1

(19) **United States**
(12) **Patent Application Publication**
Durand

(10) **Pub. No.: US 2015/0305667 A1**
(43) **Pub. Date: Oct. 29, 2015**

(54) **LOW FREQUENCY NON-INVASIVE
SENSORIAL STIMULATION FOR SEIZURE
CONTROL**

(52) **U.S. Cl.**
CPC *A61B 5/4094* (2013.01); *A61M 21/00*
(2013.01); *A61B 5/0476* (2013.01); *A61B*
5/4812 (2013.01); *A61M 2021/0027* (2013.01);
A61M 2021/0044 (2013.01); *A61M 2210/06*
(2013.01)

(71) Applicant: **Case Western Reserve University,**
Cleveland, OH (US)

(72) Inventor: **Dominique Durand,** Cleveland, OH
(US)

(57) **ABSTRACT**

(21) Appl. No.: **14/683,197**

(22) Filed: **Apr. 10, 2015**

Example apparatus and methods reduce epileptic seizures in a human patient by non-invasively providing low frequency (e.g., 1-10 Hz) audio stimuli coordinated with low frequency (e.g., 1-10 Hz) visual stimuli to the patient. The signals are provided non-invasively through the eyes and ears. The audio stimuli and visual stimuli may be selected or coordinated based on a state (e.g., hyperexcitability, imminent epileptic seizure, epileptic seizure in progress, REM sleep) determined from an EEG signal acquired from the patient. Apparatus for delivering the audio stimuli and visual stimuli may be incorporated into a single wearable apparatus (e.g., glasses with earphones, hat, headband). The single wearable apparatus may also provide noise cancellation and visual stimulus diminution. The audio stimuli may be incorporated into music or random background noise.

Related U.S. Application Data

(60) Provisional application No. 61/983,105, filed on Apr. 23, 2014.

Publication Classification

(51) **Int. Cl.**
A61B 5/00 (2006.01)
A61B 5/0476 (2006.01)
A61M 21/00 (2006.01)

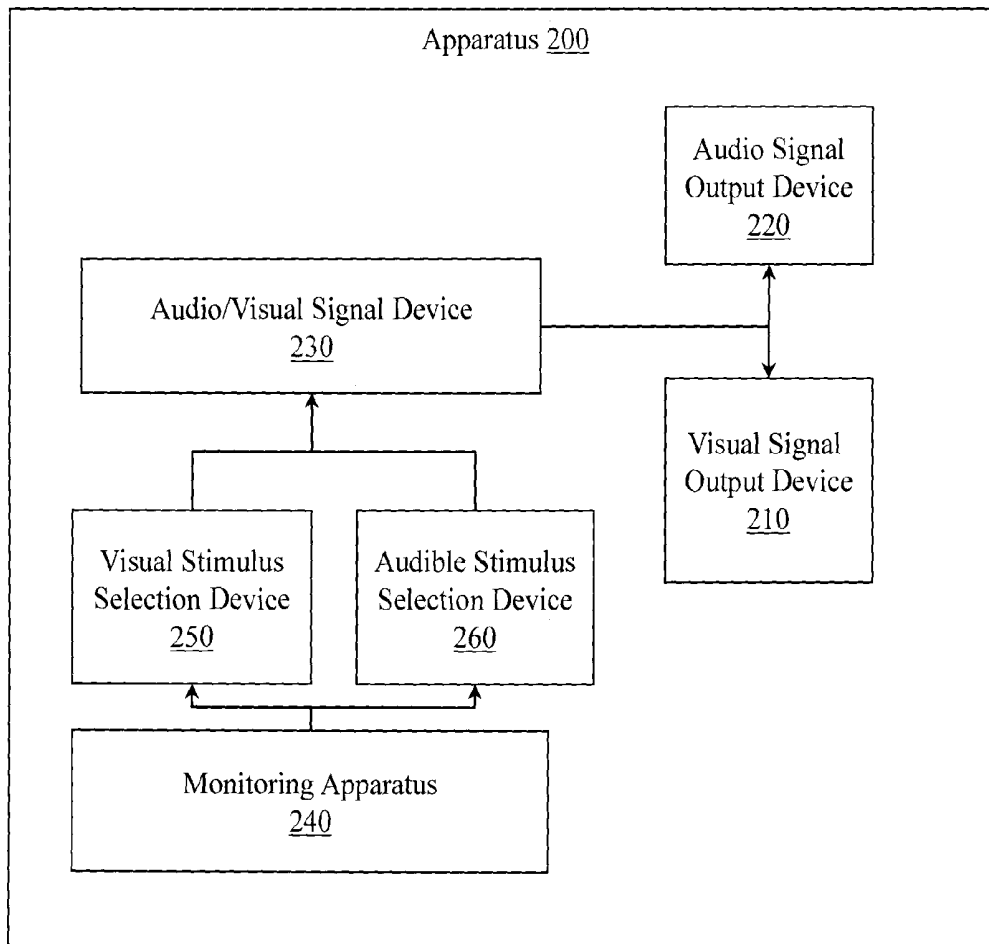

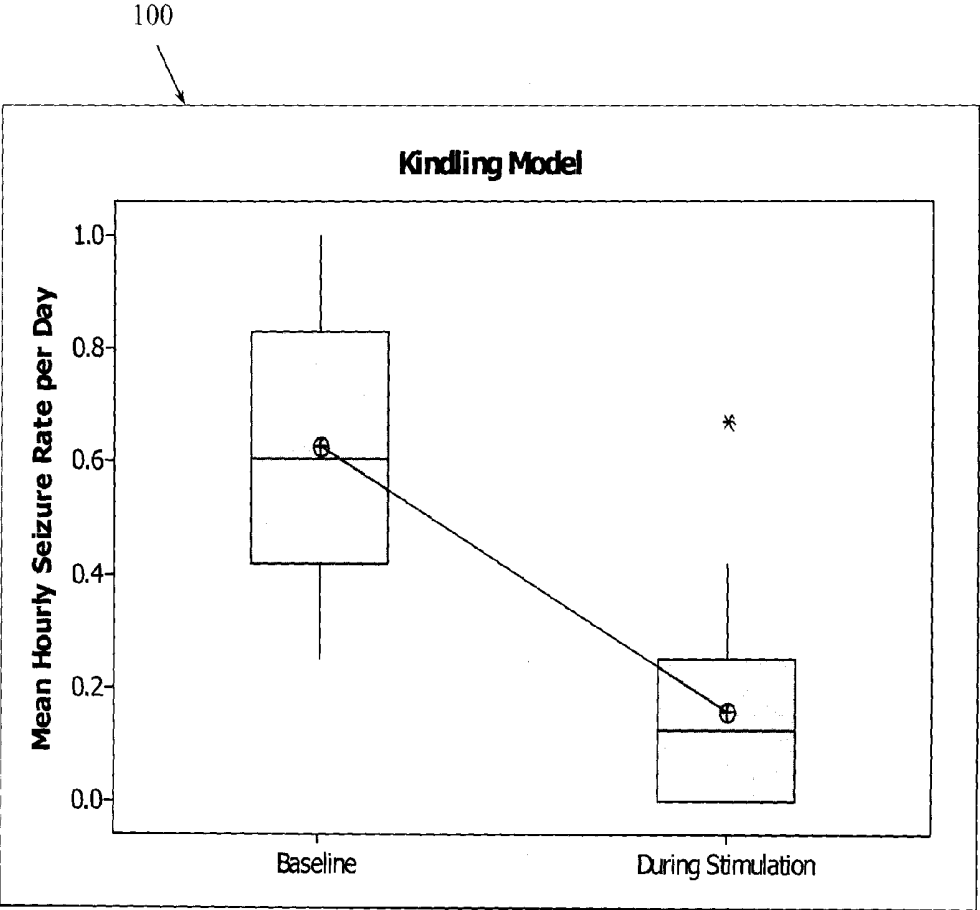

Figure 1

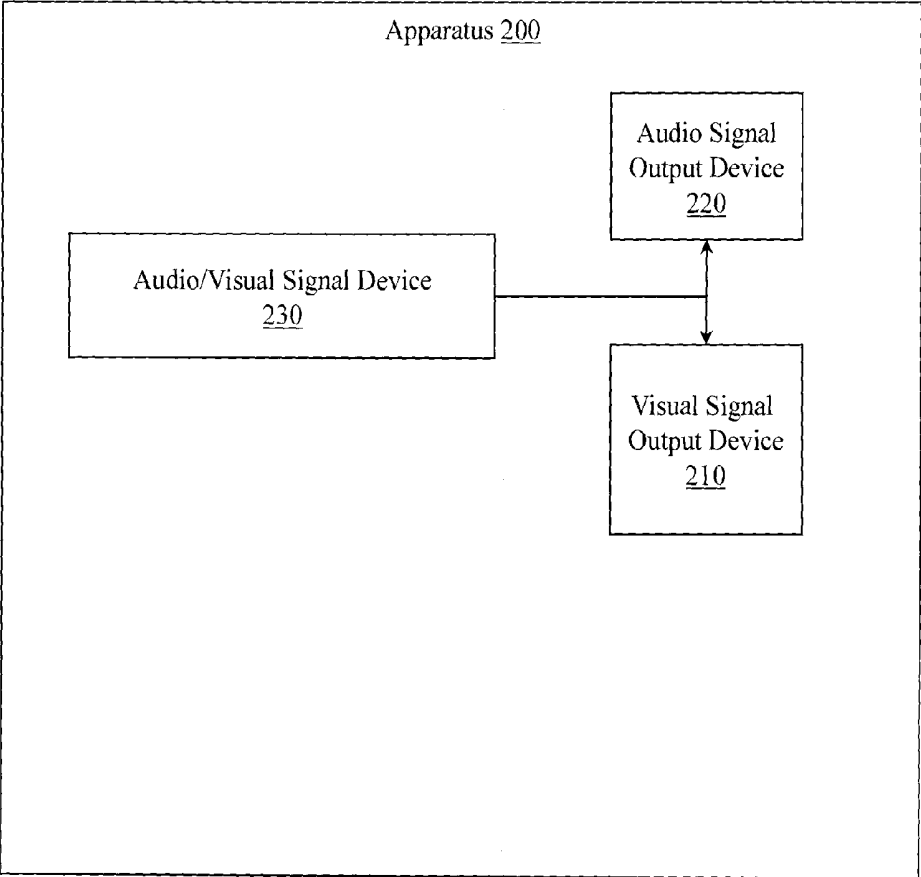

Figure 2

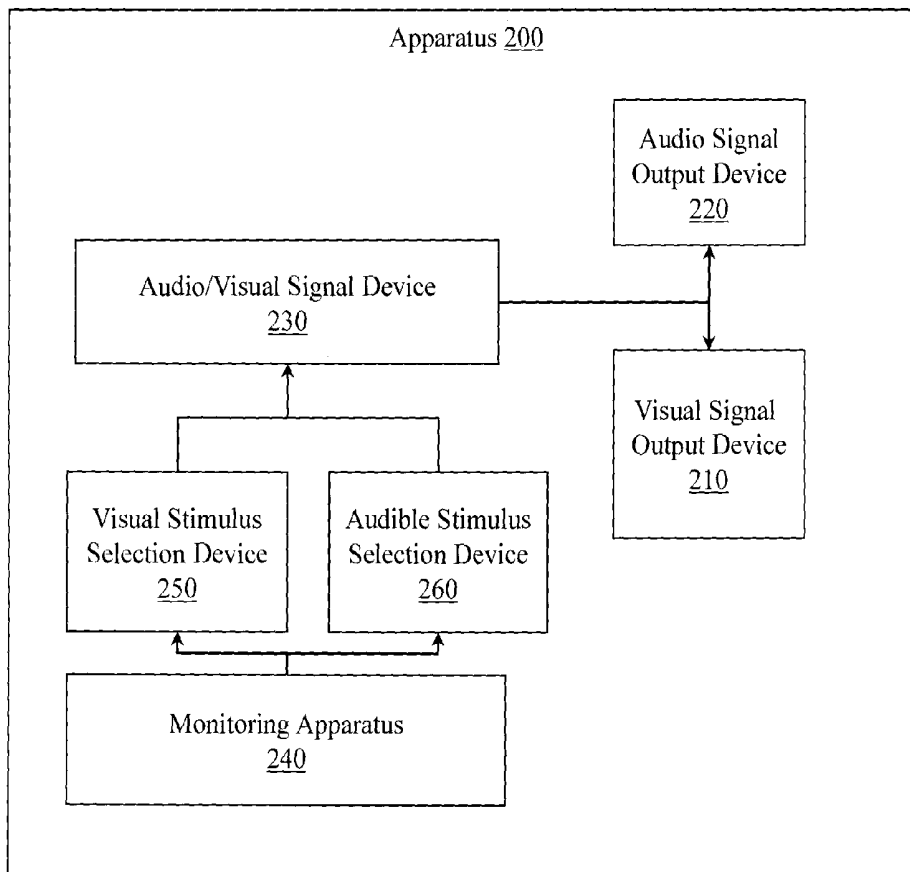

Figure 3

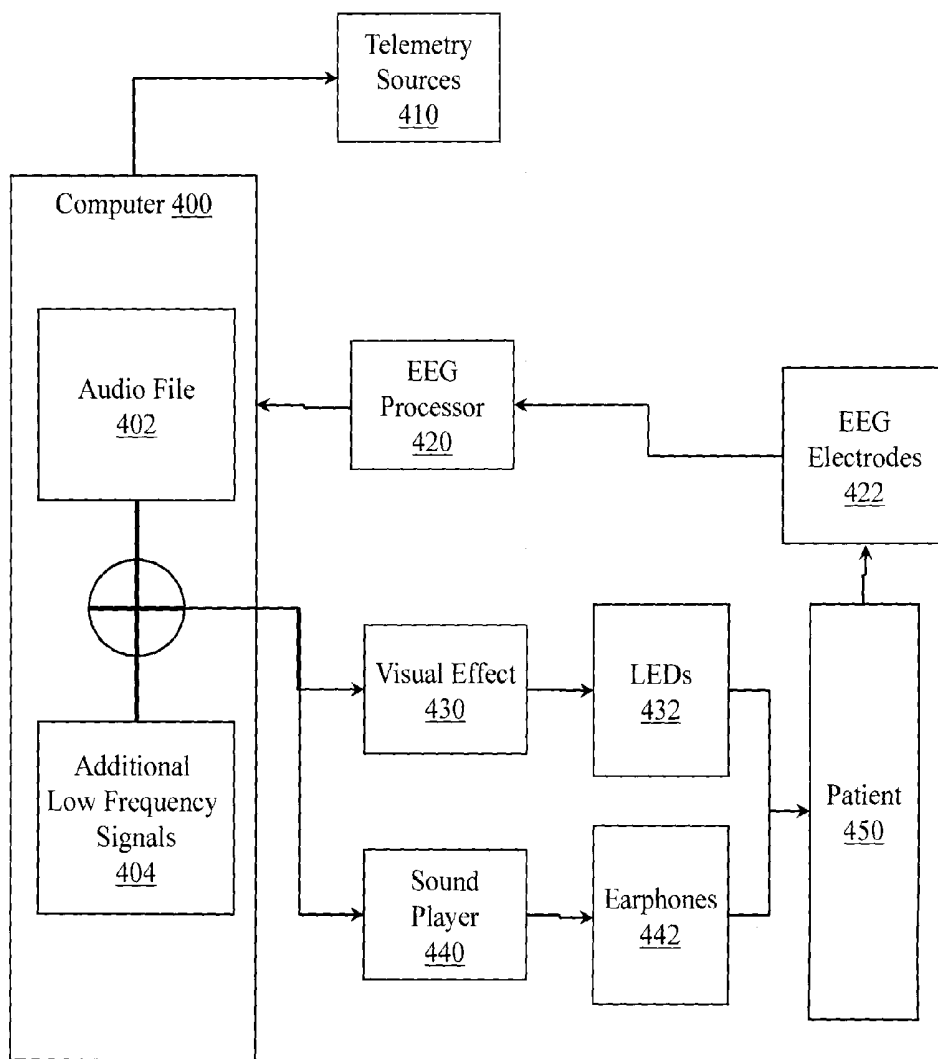

Figure 4

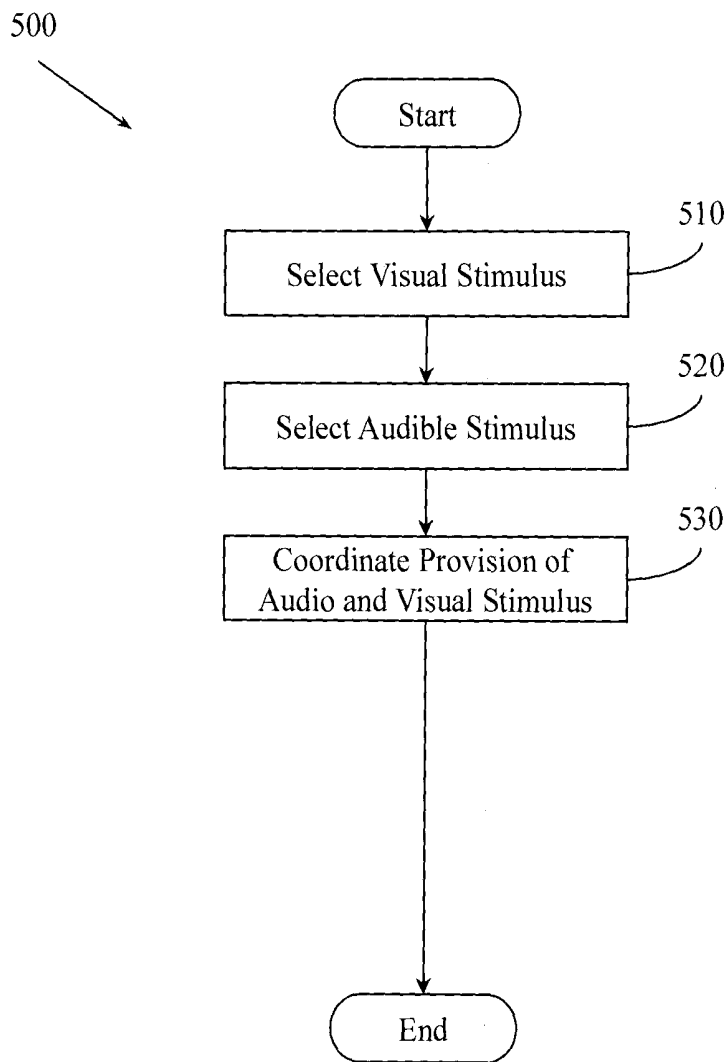

Figure 5

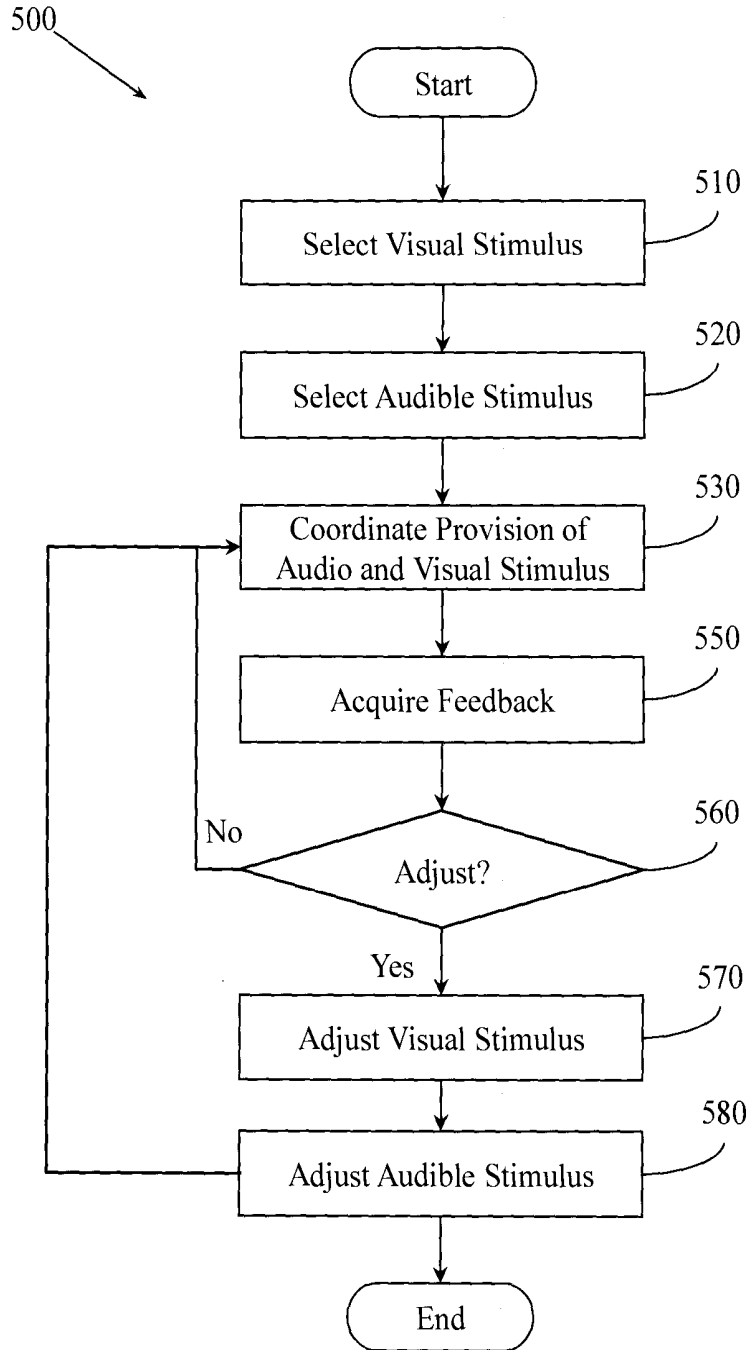

Figure 6

LOW FREQUENCY NON-INVASIVE SENSORIAL STIMULATION FOR SEIZURE CONTROL

CROSS-REFERENCE TO RELATED APPLICATIONS

[0001] This Application claims the benefit of U.S. Provisional Patent Application No. 61/983,105 filed Apr. 23, 2014.

BACKGROUND

[0002] Epilepsy is a devastating neurological disease that affects more than three million Americans and fifty million people worldwide. There are more people with epilepsy than multiple sclerosis, cerebral palsy, muscular dystrophy and Parkinson's disease combined. Epilepsy takes more lives than breast cancer. In over thirty percent of patients, seizures are not controlled, even with state of the art medical treatments. The cognitive and emotional lives of many patients are constantly being disrupted. Improvements in treatments have come slowly as scientists have learned more about the physiological changes underlying epilepsy and have developed new methods for modifying brain activity.

[0003] Current therapy for drug resistant patients with epilepsy is surgery. However, surgery may only be appropriate for patients that have an identified single focus and for patients with a focus that is located in areas of the brain that can be resected with acceptable side effects. New alternative treatments offer hope to patients who have not had success with existing drugs. These alternative treatments include vagal nerve stimulation (VNS), deep brain electrical stimulation (DBS), or trans-cranial magnetic stimulation (TMS). These procedures may send pulses of energy at constant amplitude and frequency to control excessive brain wave activity.

[0004] These procedures may use low frequency (1-10 Hz) stimulus in order to entrain the network. Low frequency stimulation has been shown to reduce seizure frequency. For example, techniques including DBS, cortical electrical stimulation, VNS and TMS have produced seizure reduction in human subjects.

BRIEF DESCRIPTION OF THE DRAWINGS

[0005] The accompanying drawings, which are incorporated in and constitute a part of the specification, illustrate various example devices, methods, apparatus and other embodiments of various aspects of the invention. It will be appreciated that the illustrated element boundaries (e.g., boxes, groups of boxes, or other shapes) in the figures represent one example of the boundaries. In some embodiments one element may be designed as multiple elements, multiple elements may be designed as one element, an element shown as an internal component of another element may be implemented as an external component and vice versa, and so on. Furthermore, elements may not be drawn to scale.

[0006] FIG. 1 illustrates the results of a non-invasive stimulation study using example apparatus and methods in rats.

[0007] FIG. 2 illustrates an apparatus for low frequency non-invasive sensorial stimulation for seizure control.

[0008] FIG. 3 illustrates an apparatus for low frequency non-invasive sensorial stimulation for seizure control.

[0009] FIG. 4 illustrates a system for low frequency non-invasive sensorial stimulation for seizure control.

[0010] FIG. 5 illustrates an example method for low frequency non-invasive sensorial stimulation for seizure control.

[0011] FIG. 6 illustrates an example method for low frequency non-invasive sensorial stimulation for seizure control.

DETAILED DESCRIPTION

[0012] Example apparatus and methods reduce epileptic seizures in a human patient by non-invasively providing low frequency (e.g., 1-10 Hz) audio stimuli coordinated with low frequency (e.g., 1-10 Hz) visual stimuli to the patient. The signals are provided non-invasively through the eyes and ears. Non-invasively means using the senses of sight and hearing through the eyes and ears without using an implanted electrode to electrically stimulate a nerve. The audio stimuli and visual stimuli may be selected or coordinated based on a state (e.g., hyperexcitability, imminent epileptic seizure, epileptic seizure in progress, rapid eye movement (REM) sleep) determined from an electroencephalogram (EEG) signal acquired from the patient. Apparatus for delivering the audio stimuli and visual stimuli may be incorporated into a single wearable apparatus (e.g., glasses with earphones, hat, headband). The single wearable apparatus may also provide noise cancellation and visual stimulus diminution. The audio stimuli may be incorporated into music or random background noise. Coordinating the audio stimuli and visual stimuli may include providing only audio stimuli or visual stimuli but not both.

[0013] Example apparatus and methods perform combined visual and auditory stimulation at low frequency (1-10 Hz) using electrical currents, optogenetic stimulus, and sensorial stimulation to reduce seizure frequency by seventy to ninety percent. Optogenetic stimulus may include neural stimulation in genetically modified light sensitive neurons. FIG. 1 illustrates the results of a non-invasive stimulation study using example apparatus and methods in rats. In one embodiment, a combination of click sounds and short white light pulses delivered at 1 Hz induced a 70% reduction of seizure frequency in two different animal models of epilepsy. In one experiment, rats were exposed to visual and auditory clicks for twelve hours per day for a week. 70% reduction was observed for the kindling model (Rashid and Durand 2012) of epilepsy, which showed that low frequency stimulation of ventral hippocampal commissures reduces seizures in a rat model of chronic temporal lobe epilepsy. 50% reduction was observed in the kainic acid model.

[0014] Auditory stimulation has been demonstrated to be effective at controlling seizures. In one study, twenty-three of twenty-nine patients with focal discharges or bursts of generalized spike and wave complexes who listened to the Mozart piano sonata K448 showed significant decreases in epileptiform activity. Similarly, listening to the Mozart piano sonata was effective in 8/11 patients with refractory epilepsy. Listening to the sonata had antiepileptic long lasting effects in eighty children for six months. The spectrum of Mozart K448 published by the Taiwanese group is 1 Hz. While auditory stimulation alone may produce positive results, example apparatus and methods employ a combined visual and auditory approach to produce superior results.

[0015] Deep Brain Stimulation (DBS) and Vagal Nerve Stimulation (VNS) require surgery that is inherently disruptive of the brain and body integrity. Transcranial magnetic stimulation (TMS) is difficult to deliver to outpatients and is not yet available for daily home applications. Example apparatus and methods that employ combined visual and auditory low frequency sensorial stimulation (LFSS) facilitate apply-

ing principles of phase synchronization while avoiding the requirement of surgery or the use of bulky or expensive equipment. LFSS is simply and flexibly applied using, for example, an open loop system. Example apparatus and methods may be configurable to allow the audio or visual elements of LFSS to be adapted to patient age or preferences. For example, some patients may prefer to listen to a first type of music (e.g., classical) while other patients may prefer to listen to a second type of music (e.g., pop). LFSS may be suitable as an adjuvant to anti-epileptic medication for all patients with epilepsy. LFSS may be particularly suitable for children for whom DBS is not recommended and for whom VNS may not be effective.

[0016] Example LFSS may be implemented with a device having a sleeping mask for the eyes, ear phones, EEG electrodes, and an electronic processing unit. More generally an LFSS system may include a visual signal output device, an audio signal output device, a monitor apparatus, and an audio/visual signal production apparatus. The eye mask may be designed on a per patient basis, for populations (e.g., adults, children), or in other ways. The eye mask may be designed to reduce the spectrum of stimulation presented to the eyes to just the intended sensorial stimulation. The eye mask may be dark, comfortable, and may have enough clearance between the mask shell and the eyelids to avoid eye blink frictions. Light emitting components (e.g., LEDs, infrared emitters) may be embedded or otherwise associated with the mask to emit, for example, a low intensity glow that can penetrate the eyelids. Earphones may be designed to eliminate external inputs, which may be referred to as performing noise cancellation. Noise cancellation may be employed since listening to music with closed eyes increases the general activation of sensorial and limbic areas of the brain. The earphones may be plugged into or otherwise operably connected to a sound generating device. The sound generating device may be, for example, a small computer capable of playing high quality stereo music. The device may be, for example, an MP3 player (e.g., iPod®)

[0017] A computer, circuit, or other apparatus or control process may synchronize light production/delivery and sound production/delivery. EEG electrodes may record the seizure activity for the patient. In different embodiments, the EEG electrodes may be placed next to or on the ear phones. In one embodiment, the audio signal device may provide music with embedded "clicks". The music may have a tempo between, for example, 1 and 10 Hz. Music tracks may be composed directly for LFSS or may be arranged by adding some low frequency sounds synchronized to the original tempo to an already existing track. In one embodiment, random noise with added clicks or short tones may be employed.

[0018] In one embodiment, the components may be arranged in an open loop. The components may include just the audio/visual stimulation system. In one embodiment, the duration, timing, frequency, or other parameters of the stimulation may be programmed by a physician and implemented in a computer that provides or controls the stimuli. As computing power has become ever more miniaturized, the computer may be, for example, a smart phone, PDA, or other small (e.g., portable) device placed next to the patient. In one embodiment, the computer may be integrated into a wearable article.

[0019] In one embodiment, the components may also include EEG equipment. The EEG equipment (e.g., electrodes, monitoring circuit) may track seizure activity (e.g.,

number of seizures, duration of seizures, intensity of seizures) for the patient. In one embodiment, seizure detection may monitor the success of the therapy. The EEG signal may, for example, be stored on the computer, be transmitted to a treating neurologist, or be provided to other monitoring personnel or processes.

[0020] In one embodiment, the system may operate in a closed loop to match the stimuli to a particular condition of the patient. For example, stimulation may be selectively applied during REM sleep or when interictal activity within the EEG indicates hyperexcitability in the brain.

[0021] FIG. 2 illustrates an apparatus 200 for reducing epileptic seizures in a human patient by non-invasively providing coordinated low frequency audio stimuli and low frequency visual stimuli to the patient. Apparatus 200 includes a visual signal output device 210 that provides an external visual stimulus having a frequency of 1-10 Hz to the visual system of the patient. The external visual stimulus may be produced by, for example, a light emitting diode (LED), an infrared (IR) device, or other device that produces stimuli that can be perceived by the human eye. The external stimulus is provided without mechanical contact with the eye and without electrode penetration of the eye or optic nerve.

[0022] Apparatus 200 also includes an audio signal output device 220 that provides an external audible stimulus having a frequency of 1-10 Hz to the hearing system of the patient. The external audible stimulus may be produced by, for example, a speaker, a membrane, a diaphragm, or other device that produces stimuli that can be perceived by the human ear. In one embodiment, the audible signal is embedded in a piece of music or is embedded in random noise. The external stimulus is provided without mechanical contact of the tympanic membrane and without electrode penetration of the cochlear nerve or vestibular nerve.

[0023] Apparatus 200 also includes an audio/visual signal device 230 that controls the visual signal output device 210 and the audio signal output device 220 to coordinate the provision of the visual stimulus and the audible stimulus. Coordinating the provision of the visual stimulus and the audible stimulus may include, for example, controlling the times at which the visual stimulus and the audible stimulus are provided, controlling how many presentations of the visual stimulus are made per presentation of the audible stimulus, controlling how many presentations of the audible stimulus are made per presentation of the visible stimulus, or other actions. In one embodiment, the audio/visual signal device 230 synchronizes the audible signal to a piece of music and or to random noise. In one embodiment, the visual signal output device 210 and the audio signal output device 220 are controlled to present the visual stimuli and the audio stimuli so that neural signals generated in response to the visual stimuli and the audio stimuli arrive in target locations within a defined window of time. In one embodiment, apparatus 200 may provide only an audio stimuli or visual stimuli but not both.

[0024] In one embodiment, the apparatus 200 may be a single wearable apparatus. For example, apparatus 200 may be embodied in a pair of glasses having sound producing elements near the ears and light producing elements near the eyes. In another embodiment, apparatus 200 may be a headband that wraps around the eyes and ears. The headband may be elasticized and may be suitable for wearing to bed.

[0025] In different embodiments, the visual signal output device 210 may be glasses, a mask, an eye patch, a monocle,

or a visor. In different embodiments, the audio signal output device **220** may be earphones, an earbud, glasses, or a surface transducer. In one embodiment, to reduce unwanted visual stimulation, the visual signal output device **210** may reduce the spectrum, intensity, or other attribute(s) of external visual stimulation experienced by the patient to a desired stimulation spectrum. Reducing the spectrum, intensity, or other attributes may involve filtering light, blocking light, or otherwise reducing the light presented to the patient other than light from the visual signal output device **210**. Similarly, to reduce unwanted audible stimulation, the audio signal output device **220** may perform noise cancellation. Performing noise cancellation may include, for example, reducing the spectrum, amplitude, intensity, or other attributes of sounds presented to the patient other than sounds from the audio signal output device **220**.

[0026] FIG. 3 illustrates another embodiment of apparatus **200**. This embodiment includes a monitoring apparatus **240** that identifies a state in the brain of the patient. The monitoring apparatus **240** may be, for example, an electroencephalogram (EEG) device. The monitoring apparatus **240** may be configured (e.g., programmed, wired) to identify states including, for example, hyperexcitability in the brain, an imminent epileptic seizure in the patient, an epileptic seizure in progress in the patient, a REM sleep state being experienced by the patient, or a non-REM sleep state being experienced by the patient.

[0027] This embodiment of apparatus **200** also includes a visual stimulus selection device **250** that selects the visual stimulus based, at least in part, on the state. Selecting the visual stimulus may include, for example, selecting a frequency for the visual stimulus, selecting an intensity of the visual stimulus, selecting a color for the visual stimulus, or selecting another attribute of the visual stimulus.

[0028] This embodiment of apparatus **200** also includes an audio signal selection device **260** that selects the audible stimulus based, at least in part, on the state. Selecting the audible stimulus may include, for example, selecting a frequency for the audible stimulus, selecting an intensity of the audible stimulus, selecting a tone for the audible stimulus, or selecting another attribute of the audible stimulus.

[0029] In this embodiment of apparatus **200**, since the state of the patient brain may be known, the audio/visual signal device **230** may control the visual signal output device **210** and the audio signal output device **220** to coordinate the provision of the visual stimulus and the audible stimulus based, at least in part, on the state. For example, the number of presentations of the visual stimulus compared to the number of presentations of the audible stimulus may be adjusted, the time interval between presentations of the stimuli may be adjusted, and other coordination parameters may be adjusted. Based on the state, only a visual stimulus or an audible stimulus but not both may be provided.

[0030] In one embodiment, apparatus **200** may also include a direct stimulation control circuit that controls direct stimulation of a sensory nerve of the patient. In this embodiment, the audio/visual signal device **230** may coordinate the direct stimulation with the visual stimuli or the audio stimuli.

[0031] FIG. 4 illustrates a computer **400** that is part of a system for providing low-frequency non-invasive sensorial stimulation for seizure control. Computer **400** may store an audio file **402** and additional low frequency signals **404** that may be combined and provided by computer **400**. The low frequency signals **404** may be in the range of 1-10 Hz. Com-

puter **400** may provide sounds generated from the audio file **402** and the additional low frequency signals **404** to a sound player **440**. Sound player **440** may in turn provide signals to earphones **442**. The signals provided to earphones **442** may be signals from which audible sounds can be provided to a patient **450**.

[0032] Computer **400** may also provide signals to a visual effect apparatus or circuit **430**. The visual effect element **430** may in turn provide signals to an output device (e.g., light emitting diodes **432**) from which visible stimuli can be provided to patient **450**. Computer **400** may provide the signals to the sound player **440** and to the visual effect circuit **430** in a manner that facilitates controlling how and when the earphones **442** and LEDs **432** provide the audible and visual stimuli to the patient **450**. For example, the ratio of visual stimuli to audible stimuli may be controlled by computer **400**. Similarly, the relative intensities of the visual stimuli and audible stimuli may be controlled by computer **400**. In one embodiment, the signals may be provided to the patient **450** with no feedback. In another embodiment, the patient **450** may be monitored by, for example, EEG electrodes **422**. The EEG electrodes **422** may provide signals to an EEG processor **420** that in turn provides signals to the computer **400**. Computer **400** may then use the feedback from the patient **450** to control how subsequent signals are provided to the visual effect circuit **430** or the sound player **440**. In one embodiment, computer **400** may also provide output signals to various telemetry sources **410** that may be monitoring or otherwise tracking the patient **450** or the computer **400**.

[0033] Some portions of the detailed descriptions that follow are presented in terms of algorithms and symbolic representations of operations on data bits within a memory. These algorithmic descriptions and representations are used by those skilled in the art to convey the substance of their work to others. An algorithm, here and generally, is conceived to be a sequence of operations that produce a result. The operations may include physical manipulations of physical quantities. Usually, though not necessarily, the physical quantities take the form of electrical or magnetic signals capable of being stored, transferred, combined, compared, and otherwise manipulated in a logic, and so on. The physical manipulations create a concrete, tangible, useful, real-world result.

[0034] It has proven convenient at times, principally for reasons of common usage, to refer to these signals as bits, values, elements, symbols, characters, terms, numbers, and so on. It should be borne in mind, however, that these and similar terms are to be associated with the appropriate physical quantities and are merely convenient labels applied to these quantities. Unless specifically stated otherwise, it is appreciated that throughout the description, terms including processing, computing, determining, and so on, refer to actions and processes of a computer system, logic, processor, or similar electronic device that manipulates and transforms data represented as physical (electronic) quantities.

[0035] Example methods may be better appreciated with reference to flow diagrams. While for purposes of simplicity of explanation, the illustrated methodologies are shown and described as a series of blocks, it is to be appreciated that the methodologies are not limited by the order of the blocks, as some blocks can occur in different orders and/or concurrently with other blocks from that shown and described. Moreover, less than all the illustrated blocks may be required to implement an example methodology. Blocks may be combined or

separated into multiple components. Furthermore, additional and/or alternative methodologies can employ additional, not illustrated blocks.

[0036] FIG. 5 illustrates an example method 500 for low frequency non-invasive sensorial stimulation for seizure control. Method 500 facilitates reducing epileptic seizures in a human patient. Method 500 includes, at 510, selecting a visual stimulus to provide to the patient. The visual stimulus may be a visible light or otherwise detectable spectra (e.g., infrared) comprising a plurality of illuminations displayed at 1-10 Hz. Method 500 also includes, at 520, selecting an audible stimulus to provide to the patient. The audible stimulus is an audible sound comprising a plurality of sounds presented at 1-10 Hz. The sounds may include, for example, a click. In one embodiment, the audible stimulus may be embedded in a piece of music. In another embodiment, the audible stimulus may be embedded in random noise.

[0037] Method 500 also includes, at 530, coordinating the providing of the visual stimulus and the audible stimulus. Coordinating the providing of the visual stimulus and the audible stimulus may include, for example, causing the two stimuli to be provided at the same time, causing the two stimuli to be provided in an alternating fashion, causing just one of the stimuli to be provided, or providing the two stimuli to be provided in different patterns with different numbers of presentations and different timings between presentations. Coordinating the providing of the two stimuli may include, for example, controlling a time interval between applications of the different stimuli, controlling how many of one stimuli are provided per instance of the other stimuli, controlling the relative intensity of the different stimuli, or other actions.

[0038] FIG. 6 illustrates another embodiment of method 500. This embodiment also includes, at 550, acquiring feedback from the brain of the patient. In one embodiment, acquiring the feedback may include detecting an EEG signal from the human patient. The EEG signal may indicate a state in the brain of the patient. The state may be, for example, hyperexcitability, an imminent epileptic seizure, an ongoing epileptic seizure, a REM sleep state, a non-REM sleep state, or another state.

[0039] Once the state is determined from the EEG signal, method 500 may continue, at 560, to make a determination about whether to adjust the visual stimulus, the audible stimulus, or how the visual stimulus and audible stimulus are coordinated. If the determination at 560 is no, then method 500 may return to 530. But if the determination at 560 is yes, then method 500 may proceed, at 570, by manipulating the visual stimulus based, at least in part, on the state. Method 500 may then proceed, at 580, by manipulating the audible stimulus based, at least in part, on the state. Once the visual stimulus and audible stimulus have been adjusted, method 500 may return to 530 and selectively manipulate the coordinating of the visual stimulus and the audible stimulus based, at least in part, on the state. Adjusting the visual stimulus may include, for example, changing the frequency of the visual stimulus, changing the intensity of the visual stimulus, changing a pattern in which the visual stimulus is provided, stopping the visual stimulus, or other changes. Adjusting the audible stimulus may include, for example, changing the frequency of the audible stimulus, changing the intensity of the audible stimulus, changing a pattern in which the audible stimulus is provided, stopping the audible stimulus, or other changes. Adjusting the coordination between the visual stimulus and

the audible stimulus may include, for example, changing the temporal relationship between when the different stimuli are provided.

[0040] In one embodiment, method 500 may take active steps to alter the environment in which the visual stimulus and audible stimulus are provided. For example, method 500 may include controlling an apparatus to selectively block or otherwise limit undesired visual stimulation to the patient or to selectively block or otherwise limit undesired audible stimulation to the patient.

[0041] References to “one embodiment”, “an embodiment”, “one example”, and “an example” indicate that the embodiment(s) or example(s) so described may include a particular feature, structure, characteristic, property, element, or limitation, but that not every embodiment or example necessarily includes that particular feature, structure, characteristic, property, element or limitation. Furthermore, repeated use of the phrase “in one embodiment” does not necessarily refer to the same embodiment, though it may.

[0042] “Logic”, as used herein, includes but is not limited to hardware, firmware, software in execution on a machine, or combinations of each to perform a function(s) or an action(s), or to cause a function or action from another logic, method, or system. Logic may include a software controlled microprocessor, a discrete logic (e.g., ASIC), an analog circuit, a digital circuit, a programmed logic device, a memory device containing instructions, and other physical devices. Logic may include one or more gates, combinations of gates, or other circuit components. Where multiple logical logics are described, it may be possible to incorporate the multiple logical logics into one physical logic. Similarly, where a single logical logic is described, it may be possible to distribute that single logical logic between multiple physical logics.

[0043] To the extent that the term “includes” or “including” is employed in the detailed description or the claims, it is intended to be inclusive in a manner similar to the term “comprising” as that term is interpreted when employed as a transitional word in a claim.

[0044] Throughout this specification and the claims that follow, unless the context requires otherwise, the words ‘comprise’ and ‘include’ and variations such as ‘comprising’ and ‘including’ will be understood to be terms of inclusion and not exclusion. For example, when such terms are used to refer to a stated integer or group of integers, such terms do not imply the exclusion of any other integer or group of integers.

[0045] To the extent that the term “or” is employed in the detailed description or claims (e.g., A or B) it is intended to mean “A or B or both”. The term “and/or” is used in the same manner, meaning “A or B or both”. When the applicants intend to indicate “only A or B but not both” then the term “only A or B but not both” will be employed. Thus, use of the term “or” herein is the inclusive, and not the exclusive use. See, Bryan A. Garner, A Dictionary of Modern Legal Usage 624 (2d. Ed. 1995).

[0046] While example systems, methods, and so on have been illustrated by describing examples, and while the examples have been described in considerable detail, it is not the intention of the applicants to restrict or in any way limit the scope of the appended claims to such detail. It is, of course, not possible to describe every conceivable combination of components or methodologies for purposes of describing the systems, methods, and so on described herein. Therefore, the invention is not limited to the specific details, the representative apparatus, and illustrative examples shown

and described. Thus, this application is intended to embrace alterations, modifications, and variations that fall within the scope of the appended claims.

What is claimed is:

1. An apparatus for reducing epileptic seizures in a human patient by non-invasively providing coordinated low frequency audio stimuli and low frequency visual stimuli to the patient, the apparatus comprising:

a visual signal output device that provides an external visual stimulus having a frequency of 1-10 Hz to the visual system of the patient;

an audio signal output device that provides an external audible stimulus having a frequency of 1-10 Hz to the hearing system of the patient; and

an audio/visual signal device that controls the visual signal output device and the audio signal output device to coordinate the presentation of the visual stimulus and the audible stimulus.

2. The apparatus of claim 1, where the apparatus is a single wearable apparatus.

3. The apparatus of claim 1, comprising a monitoring apparatus that identifies a state in the brain of the patient.

4. The apparatus of claim 3, the state being hyperexcitability, an imminent epileptic seizure, an ongoing epileptic seizure, a rapid eye movement (REM) sleep state, or a non-REM sleep state.

5. The apparatus of claim 4, comprising a visual stimulus selection device that selects the visual stimulus based, at least in part, on the state.

6. The apparatus of claim 4, comprising an audio signal selection device that selects the audible stimulus based, at least in part, on the state.

7. The apparatus of claim 5, comprising an audio signal selection device that selects the audible stimulus based, at least in part, on the state.

8. The apparatus of claim 7, where the audio/visual signal device controls the visual signal output device and the audio signal output device to coordinate the provision of the visual stimulus and the audible stimulus based, at least in part, on the state.

9. The apparatus of claim 1, the visual signal output device being glasses, a mask, an eye patch, a monocle, or a visor.

10. The apparatus of claim 1, where the visual signal output device includes a light emitting diode (LED) or infrared emitting device.

11. The apparatus of claim 1, the audio signal output device being earphones, an earbud, glasses, or a surface transducer.

12. The apparatus of claim 3, the monitoring apparatus being an electroencephalogram (EEG) apparatus.

13. The apparatus of claim 1, where the audio/visual signal device synchronizes the audible signal to a piece of music and or to random noise.

14. The apparatus of claim 1, where the audible signal is embedded in a piece of music or is embedded in random noise.

15. The apparatus of claim 1, where the visual signal output device reduces the spectrum of external visual stimulation experienced by the patient to a desired stimulation spectrum.

16. The apparatus of claim 1, where the audio signal output device performs noise cancellation.

17. The apparatus of claim 1, where the visual signal output device and the audio signal output device are controlled to present the visual stimuli and the audio stimuli so that neural signals generated in response to the visual stimuli and the audio stimuli arrive in target locations within a defined window of time.

18. The apparatus of claim 1, comprising a direct stimulation control circuit that controls direct stimulation of a sensory nerve of the patient.

19. The apparatus of claim 18, where the audio/visual signal device coordinates the direct stimulation with the visual stimuli or the audio stimuli.

20. The apparatus of claim 1, where the visual signal output device, the audio signal output device, and the audio/visual signal device are incorporated into a single wearable item.

21. The apparatus of claim 20, the single wearable item being a headband or a hat.

22. A method for reducing epileptic seizures in a human patient, comprising:

selecting a visual stimulus to present to the patient, where the visual stimulus is a visible light comprising a plurality of illuminations displayed at 1-10 Hz;

selecting an audible stimulus to present to the patient, where the audible stimulus is an audible sound comprising a plurality of sounds presented at 1-10 Hz; and

providing the visual stimulus and the audible stimulus in a coordinated manner.

23. The method of claim 22, comprising detecting an electroencephalogram (EEG) signal from the human patient, where the EEG signal indicates a state in the brain of the patient, the state being hyperexcitability, an imminent epileptic seizure, an occurring epileptic seizure, a REM sleep state, or a non-REM sleep state.

24. The method of claim 23, comprising selectively manipulating the visual stimulus based, at least in part, on the state.

25. The method of claim 24, comprising selectively manipulating the audible stimulus based, at least in part, on the state.

26. The method of claim 25, comprising selectively manipulating the manner in which the visual stimulus and the audible stimulus are coordinated based, at least in part, on the state.

27. The method of claim 26, comprising selectively blocking undesired visual stimulation to the patient.

28. The method of claim 27, comprising selectively blocking undesired audible stimulation to the patient.

29. The method of claim 22, comprising providing the audible stimulus as part of a piece of music.

30. The method of claim 22, comprising providing the audible stimulus as part of random noise.

31. The method of claim 22, where providing the visual stimulus and the audible stimulus in a coordinated manner includes providing only the visual stimulus or the audible stimulus but not both.

* * * * *

| | | | |
|----------------|---|---------|------------|
| 专利名称(译) | 用于癫痫发作控制的低频非侵入性感觉刺激 | | |
| 公开(公告)号 | US20150305667A1 | 公开(公告)日 | 2015-10-29 |
| 申请号 | US14/683197 | 申请日 | 2015-04-10 |
| [标]申请(专利权)人(译) | 凯斯西储大学 | | |
| 申请(专利权)人(译) | 凯斯西储大学 | | |
| 当前申请(专利权)人(译) | 凯斯西储大学 | | |
| [标]发明人 | DURAND DOMINIQUE | | |
| 发明人 | DURAND, DOMINIQUE | | |
| IPC分类号 | A61B5/00 A61B5/0476 A61M21/00 | | |
| CPC分类号 | A61B5/4094 A61M21/00 A61B5/0476 A61M2210/06 A61M2021/0027 A61M2021/0044 A61B5/4812 A61B5/04842 A61B5/04845 A61B5/6803 A61B5/6898 A61B5/7203 A61M2021/0033 A61M2230/10 A61N5/0622 A61N2005/0647 A61N2005/0648 A61M2230/005 | | |
| 优先权 | 61/983105 2014-04-23 US | | |
| 其他公开文献 | US9955907 | | |
| 外部链接 | Espacenet USPTO | | |

摘要(译)

示例性装置和方法通过非侵入性地向患者提供与低频（例如，1-10Hz）视觉刺激协调的低频（例如，1-10Hz）音频刺激来减少人类患者中的癫痫发作。通过眼睛和耳朵非侵入地提供信号。可以基于从患者获取的EEG信号确定的状态（例如，过度兴奋，即将发生的癫痫发作，正在进行的癫痫发作，REM睡眠）来选择或协调音频刺激和视觉刺激。用于传递音频刺激和视觉刺激的装置可以结合到单个可穿戴装置（例如，带有耳机，帽子，头带的眼镜）中。单个可穿戴设备还可以提供噪声消除和视觉刺激减少。音频刺激可以合并到音乐或随机背景噪声中。

