



(19) **United States**

(12) **Patent Application Publication**
Beidleman et al.

(10) **Pub. No.: US 2020/0146602 A1**

(43) **Pub. Date: May 14, 2020**

- (54) **SYSTEMS AND METHODS FOR MONITORING SUBJECTS IN POTENTIAL HYPOXIC DISTRESS**
- (71) Applicant: **THE GOVERNMENT OF THE UNITED STATES, AS REPRESENTED BY THE SECRETARY OF THE ARMY, FORT DETRICK, MD (US)**
- (72) Inventors: **Beth Beidleman, Holliston, MA (US); Mark Buller, Douglas, MA (US); Alexander Welles, Brookline, MA (US)**
- (73) Assignee: **THE GOVERNMENT OF THE UNITED STATES, AS REPRESENTED BY THE SECRETARY OF THE ARMY, FORT DETRICK, MD (US)**

Publication Classification

- (51) **Int. Cl.**
A61B 5/1455 (2006.01)
A61B 5/00 (2006.01)
A61B 5/02 (2006.01)
A61B 5/08 (2006.01)
A61B 5/11 (2006.01)
A61B 5/22 (2006.01)
A61M 16/12 (2006.01)
- (52) **U.S. Cl.**
 CPC *A61B 5/14551* (2013.01); *A61B 5/7275* (2013.01); *A61B 5/4023* (2013.01); *A61M 16/12* (2013.01); *A61B 5/08* (2013.01); *A61B 5/11* (2013.01); *A61B 5/22* (2013.01); *A61B 5/02* (2013.01)

- (21) Appl. No.: **16/628,158**
- (22) PCT Filed: **Dec. 8, 2018**
- (86) PCT No.: **PCT/US2018/064637**
 § 371 (c)(1),
 (2) Date: **Jan. 2, 2020**
- Related U.S. Application Data**
- (60) Provisional application No. 62/596,511, filed on Dec. 8, 2017.

(57) **ABSTRACT**

A method of monitoring a subject for the risk of Acute Mountain Sickness (AMS) includes obtaining real-time pulse arterial oxygen saturation (SpO₂) measurements from the subject. The SpO₂ measurements are transformed into a novel metric known as Accumulated Hypoxic Debt (AHD). The AHD metric is used as the independent variable in a longitudinal generalized linear mixed model to calculate the probability D that the subject is at risk of AMS. Based on the probability D, appropriate courses of action may be communicated to the subject via the output device of a wearable or portable monitor.

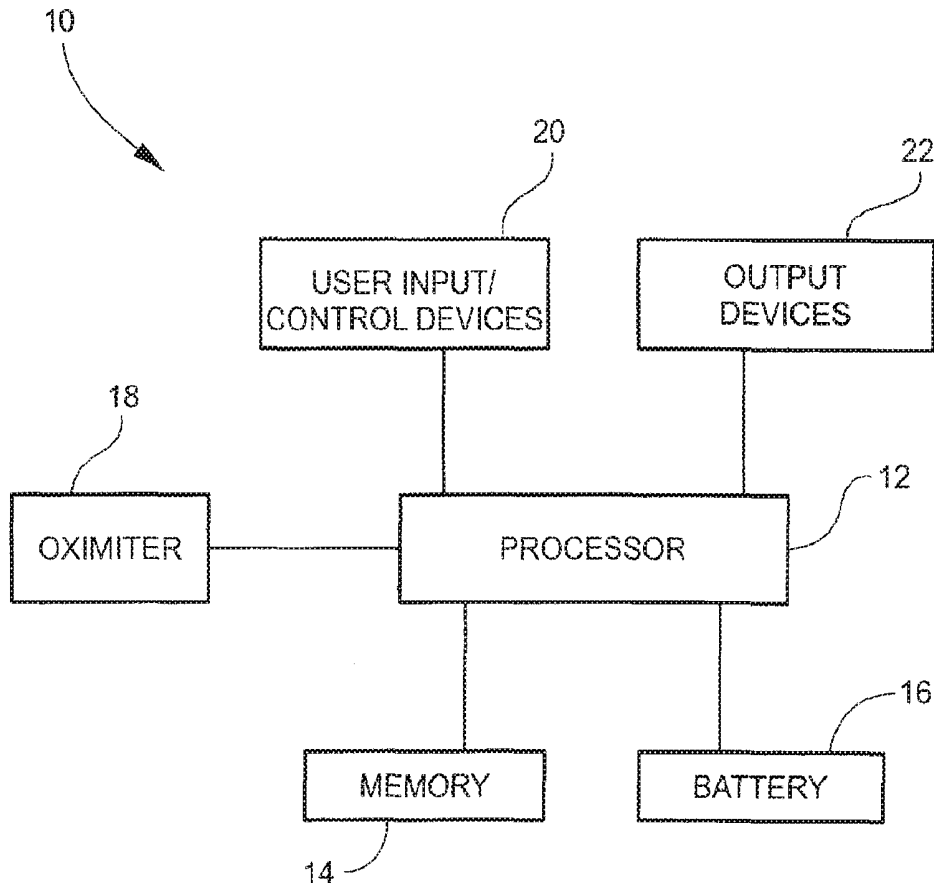

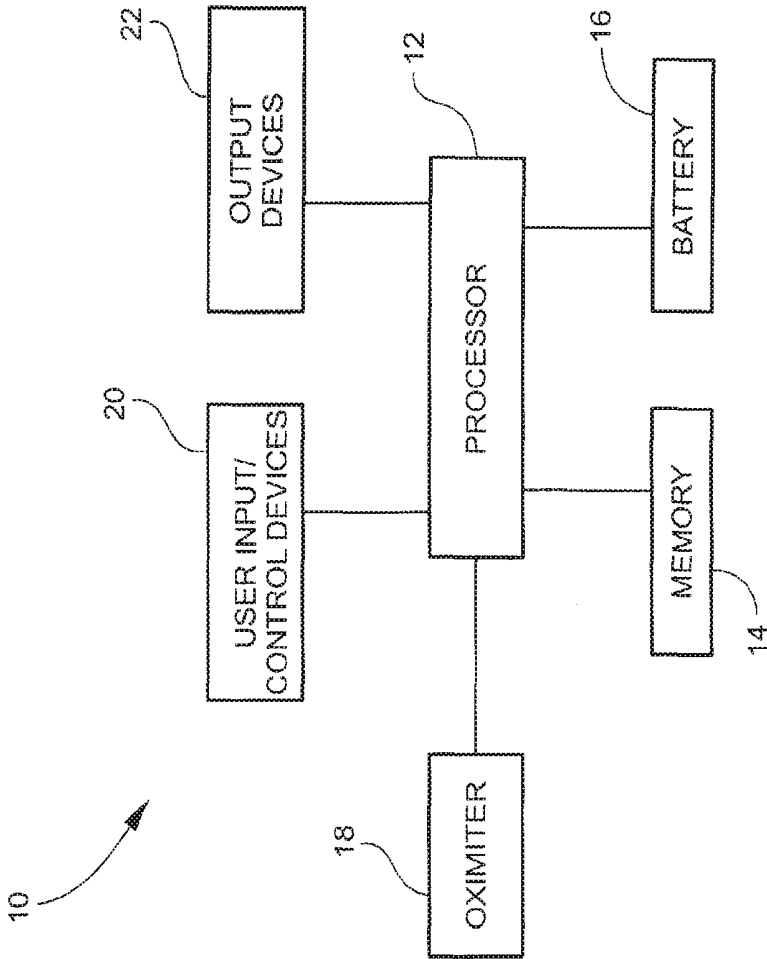

**SYSTEMS AND METHODS FOR
MONITORING SUBJECTS IN POTENTIAL
HYPOXIC DISTRESS**

CROSS REFERENCE TO RELATED
APPLICATIONS

[0001] The present application claims the benefit of priority of U.S. provisional patent application Ser. No. 62/596,511 filed on Dec. 8, 2017, which is expressly incorporated by reference herein.

STATEMENT OF GOVERNMENT INTEREST

[0002] The invention described herein may be manufactured, used and licensed by or for the United States Government.

BACKGROUND OF THE INVENTION

[0003] The invention relates in general to altitude illness and in particular to Acute Mountain Sickness (AMS).

[0004] Acute mountain sickness (AMS) is the most common altitude illness and its symptoms include headache, nausea, fatigue, decreased appetite, and poor sleep [1, 2]. (Note: The bracketed numbers at the end of a sentence refer to the references listed at the end of the specification). The number of individuals who suffer from AMS rises in direct proportion to the ascent rate and elevation [3, 4]. Unacclimatized lowlanders can experience 70-80% incidence of AMS with 40-50% having moderate to severe symptoms with rapid ascent to 4300 meters [3]. When AMS symptoms are severe, individuals can be completely incapacitated and unable to perform the simplest of tasks [5]. Large decrements in both physical and cognitive performance also occur with rapid ascent to high altitude [6-8]. Research has reported that endurance performance in events lasting 1-3 hours is impaired by 10-15% at 3000 meters and 40-80% at 4300 meters in unacclimatized lowlanders following rapid ascent [9, 10].

[0005] Research has also demonstrated that cognitive performance is impacted by 20-50% following rapid ascent to high altitudes, depending on the altitude, with unlearned complex activities affected more than well-learned simple activities [11-14]. Warfighters who are rapidly deployed to altitude may suffer from symptoms of AMS. Some security analyses conclude that there are 60 world-wide high altitude areas for possible U.S. military engagement. In addition, it is estimated that over 100 million people annually visit areas of high altitude for recreation, work and travel.

[0006] Despite decades of research, individualized real-time predictors of decrements in health and performance while visiting or residing at altitude are lacking. The clinical definition of hypoxia is pulse arterial oxygen saturation below 90%. Although technology to measure pulse arterial oxygen saturation (SpO₂) has existed for years, single point measurements of SpO₂ have not been able to predict the occurrence of AMS or decrements in physical and cognitive performance. There are currently no real-time, individualized technical methods to predict the likelihood of hypoxic events and altitude acclimatization status.

[0007] In one known technique, once an individual is at altitude, a self-assessment questionnaire (for example, the Lake Louise Scoring System) may be used to determine if the individual has AMS. The self-assessment questionnaires are not particularly helpful for predicting the risk of AMS in

real-time before it occurs. In addition, completing the questionnaire requires that the individual stop his/her current activity and devote time to assessing his/her physical and mental conditions. A need exists for a technical solution that can predict the likelihood of AMS in real-time on an individual basis, without requiring the individual to interrupt his/her activities and consume valuable time.

SUMMARY OF THE INVENTION

[0008] One aspect of the invention is a method for real-time monitoring of an individual. The method may include: (a) providing a pulse arterial oxygen saturation (SpO₂) sensor and a portable computing device to an individual; (b) using the sensor, measuring the SpO₂ value of the individual in real-time once a second; (c) using a processor in the computing device, obtaining an average real-time SpO₂ value over a time interval between 1 and 60 seconds; (d) using the processor, subtracting the average real-time SpO₂ value from 90% to obtain a real-time SpO₂ difference; (e) using the processor, multiplying the real-time SpO₂ difference by the time interval and converting the product to % hours to obtain a real-time hypoxic debt value; (f) storing the real-time hypoxic debt value in a memory of the computing device; (g) repeating steps (b)-(f) for a plurality of the time intervals; (h) using the processor, retrieving a plurality of stored real-time hypoxic debt values from the memory; (i) using the processor, summing the plurality of retrieved real-time hypoxic debt values to obtain accumulated hypoxic debt (AHD); (j) using the processor, calculating a probability (D) of experiencing acute mountain sickness as $D = \frac{e^{-1.94+0.017(AHD)}}{1+e^{-1.94+0.017(AHD)}}$; and (k) using an output device, communicating the probability D to the individual.

[0009] Step (b) may include measuring the SpO₂ value of the individual in real-time when the individual is located above an altitude of about 2500 meters.

[0010] Step (c) may include using the processor to obtain an average real-time SpO₂ value over a time interval of 15 seconds.

[0011] Step (e) may include using the processor to multiply the real-time SpO₂ difference by the time interval of 15 seconds and converting the product to % hours to obtain a real-time hypoxic debt value.

[0012] Step (g) may include repeating steps (b)-(f) for a plurality of the 15 second time intervals.

[0013] Steps (b)-(k) may be repeated over a period of 48 hours.

[0014] Step (k) may include communicating the probability D to the individual using a visual display. Step (k) may include using the output device to communicate a course of action to the individual. Step (k) may include communicating one or more of the probability D and the course of action in one or more of a numerical format, a color-coded format and a format using words.

[0015] Another aspect of the invention is a non-transitory computer-readable medium with instructions stored thereon that, when executed by a processor, a memory, a pulse arterial oxygen saturation (SpO₂) sensor, and an output device, perform the steps comprising steps (b)-(k) recited above.

[0016] A further aspect of the invention is a system for real-time monitoring of an individual for a risk of Acute Mountain Sickness. The system may include a pulse arterial oxygen saturation (SpO₂) sensor configured to extract SpO₂

measurements from the individual and a portable computing device configured to be worn or carried by the individual and connected to the SpO₂ sensor. The portable computing device may include a processor, a memory, and an output device.

[0017] The processor may be configured to (a) obtain an average real-time SpO₂ value over a 15 second time interval; (b) subtract the average real-time SpO₂ value from 90% to obtain a real-time SpO₂ difference; (c) multiply the real-time SpO₂ difference by the time period of 15 seconds and convert the product to % hours to obtain a real-time hypoxic debt value; (d) store the real-time hypoxic debt value in the memory of the computing device; (e) retrieve a plurality of stored real-time hypoxic debt values from the memory; (f) sum the plurality of retrieved real-time hypoxic debt values to obtain accumulated hypoxic debt (AHD); (g) calculate a probability (D) of experiencing acute mountain sickness as $D = e^{-1.94+0.017(AHD)} / (1 + e^{-1.94+0.017(AHD)})$; and (h) communicate the probability D to the individual by sending the probability D to the output device.

[0018] In another aspect of the invention, a method of detecting Acute Mountain Sickness (AMS) in a human includes obtaining SpO₂ measurements from the human; detecting whether the human is at risk of AMS by transforming the SpO₂ measurements to accumulated hypoxic debt (AHD); and using the AHD as an independent variable in a longitudinal generalized linear mixed model to calculate the probability D that the human is at risk of AMS.

[0019] The probability D may equal $e^{-1.94+0.017(AHD)} / (1 + e^{-1.94+0.017(AHD)})$.

[0020] The invention will be better understood, and further objects, features and advantages of the invention will become more apparent from the following description, taken in conjunction with the accompanying drawings.

BRIEF DESCRIPTION OF THE DRAWINGS

[0021] In the drawings, which are not necessarily to scale, like or corresponding parts are denoted by like or corresponding reference numerals.

[0022] The single FIGURE is a schematic diagram of one embodiment of an individualized hypoxia monitor.

DETAILED DESCRIPTION

[0023] A novel apparatus and method utilizes real-time monitoring and analysis of an individual's pulse arterial oxygen saturation (SpO₂) to predict the risk of the occurrence of Acute Mountain Sickness (AMS) during the first 48 hours at altitude (above 2500 meters). For soldiers, the first 48 hours at altitude is the riskiest. A novel, useful, unconventional and non-routine metric is "accumulated hypoxic debt (AHD)" in units of % hours.

[0024] To determine an individual's AHD, first, an individual's real-time SpO₂ is measured by a sensor worn by the individual. The real-time SpO₂ may be measured, for example, once a second. The measured real-time SpO₂ is then averaged across a relatively short time interval to obtain an average real-time SpO₂ measurement for that short time interval. In one embodiment, the short time interval is 15 seconds. In other embodiments, the short time interval may be longer or shorter than 15 seconds.

[0025] The SpO₂ difference is 90% minus the average real-time SpO₂ calculated over the short time interval. The SpO₂ difference is then multiplied by the length of the short

time interval (for example, 15 seconds (15/3600 hours)) to obtain a single hypoxic debt amount in % hours. Then, the single hypoxic debt amounts are summed over the total time interval during which SpO₂ measurements have been taken to thereby obtain the AHD in % hours.

[0026] The AHD is then used in a longitudinal generalized linear mixed model to assess the risk of experiencing AMS. The preferred model is of the form shown in Equation 1. below:

$$y_i = \sum_{j=0}^M \beta_j x_{ij} + \epsilon_i \tag{Equation 1}$$

[0027] In the model, x is the real-time measured AHD. The AHD is used to calculate y, which is the risk of experiencing AMS. The model was developed using sixteen healthy nonsmoking unacclimatized lowlanders (M=11, F=5, age=23±6 yrs, weight=74±13 kg; mean±SD) that ascended to the summit of Pikes Peak (PP) at 4300 meters and wore a physiologic status monitor (Equivital™ EQ-02) that measured pulse arterial oxygen saturation (SpO₂) every 15 seconds for the first 20 hours of altitude exposure. An Environmental Symptoms Questionnaire was utilized to measure the prevalence and severity of AMS after 4, 8, 12 and 20 hours of exposure. Data was filtered such that all volunteers had the same number of physiologic measurements. AHD (% hr) was calculated by multiplying the real-time SpO₂ difference [90%-actual SpO₂] by the time period (15 sec), converting this to % hours of hypoxic debt and then summing the hypoxic debt amounts over the total time period.

[0028] In Equation 1., the regression coefficient fl equals 0.017 and the residual variable ε equals -1.94. Thus, the percent probability D of experiencing AMS is given by Equation 2. below:

$$D = (e^{-1.94+0.017(AHD)}) / (1 + e^{-1.94+0.017(AHD)}) \tag{Equation 2.}$$

[0029] AHD was a significant predictor (P=0.002) of the occurrence of AMS over time at altitude. Every 10% hour increase in AHD increased the odds of getting AMS by 18.4% (odds ratio, 1.184; confidence interval, 1.065-1.316) [16]. The model has been externally validated in a set of ten volunteers exposed to either 3000 meters or 4000 meters and had the ability to correctly diagnose AMS 86% of the time during the first 24 hours of altitude exposure.

[0030] Using the model, Table 1. below shows the risk (%) of Acute Mountain Sickness calculated from Accumulated Hypoxic Debt (AHD) (% hr). The bracketed ranges are the 95% confidence intervals.

TABLE 1

Accumulated Hypoxic Debt (% hr)	Risk of AMS (%)
10	18.4 [6.5-31.6]
20	40.2 [13.4-73.3]
30	66.0 [20.7-228.0]
40	196 [128-300]
50	232 [137-395]
60	275 [145-520]

[0031] A very important benefit of the novel, unconventional, non-routine hypoxic debt metric is its universal nature. For instance, it can be utilized at any altitude.

Individuals will accumulate more hypoxic debt the higher the altitude and less hypoxic debt the lower the altitude. In addition, it can be utilized in men and women. Women tend to demonstrate higher SpO₂ measurements at altitude and AHD takes that variability into account. The metric also takes into account the desaturation that occurs with physical activity at altitude. Individuals engaging in vigorous physical activity experience a 5%-10% desaturation depending on the altitude, which effectively puts individuals at a higher altitude for a given period of time. Heavy physical exercise at altitude, therefore, is typically associated with higher values of AMS. In addition, medication, such as acetazolamide, stimulates ventilation, which is accounted for by the hypoxic debt metric. Last, this hypoxic debt metric captures the importance of AHD over time at altitude. Individuals do not immediately experience AMS upon arrival at altitude. AMS develops after about 4 hours of altitude exposure, peaks around 18-22 hours of exposure and then subsides after 36 hours of exposure. The real-time component of the hypoxic debt metric is useful in tracking the time course of AMS.

[0032] FIG. 1 is a schematic diagram of one embodiment of an individualized hypoxia monitor or apparatus 10. Embodiments of the apparatus 10 may include a portable computing device, for example, a wrist-worn device and/or a smartphone. Apparatus 10 either includes or is in communication with an oximeter (SpO₂ sensor) 18. Sensor 18 is connected to a processor 12. Memory 14 and battery 16 (or other power supply) are connected to the processor 12. User input and control devices 20 and output devices 22 are connected to the processor 12. The user input and control devices 20 may include, for example, keyboards (virtual or real), touch screens, microphones, movable switches, ports and jacks, such as USB ports, memory card slots, such as SD card slots, etc. Output devices 22 may include, for example, visual displays, speakers, vibrating devices, antennas, ports and jacks, such as USB ports, memory card slots, such as SD card slots, etc.

[0033] Suitable SpO₂ sensors 18 are available from, for example, Equivital, Inc., Cambridge, UK; Athena GTX, Des Moines, Iowa; Masimo, Inc., Irvine, Calif.; and Nonin, Inc., Plymouth, Minn. These companies may also provide portable and/or wearable devices that incorporate the required capabilities of processor 12, memory 14, battery 16 and input and output devices 20, 22. Many currently available smart phones models would also be suitable and can be connected to sensor 18 wirelessly via a Bluetooth® connection.

[0034] It is not necessary that the user input any information into apparatus 10 other than the real-time SpO₂ measurements provided by sensor 18. Using the real-time SpO₂ measurements, the processor 12 calculates the AHD and then uses the AHD to calculate the probability D of experiencing AMS using Equation 2. It is important to note that even if a human being could manually perform the calculations performed by the processor 12, the time required to manually calculate the real-time AHD at small time intervals, such as 15 seconds, and then manually calculate the probability D of experiencing AMS using Equation 2 would be prohibitive and would so interfere with the individual's other activities as to make doing so virtually worthless. Thus, a computer processor is a necessary and integral component of apparatus 10.

[0035] Apparatus 10 may provide the probability D to the user via an output device 22, such as a visual display. In addition, the apparatus 10 may provide a visual indication of the category of the probability P, such as MILD, MODERATE, or SEVERE, for example. In addition to or as a substitute for a textual display, apparatus 10 may visually display a color code, such as green for MILD, yellow for MODERATE, or red for SEVERE. In some embodiments, apparatus 10 may provide instructions and appropriate courses of action to the individual, for example, on a visual display. For example, if the probability D is less than 30%, then a message such as "CONTINUE ACTIVITIES" may be displayed. If D is more than 30% but less than 50%, then a message such as "STOP ASCENDING" may be displayed. If D is more than 50%, then a message such as "DESCEND IMMEDIATELY" may be displayed. When AHD is 64.3 hours, then the probability D is greater than 30%. In one embodiment, if the probability D is greater than 30%, then a change in the individual's level of activity is indicated. Other instructions and other ranges of probabilities may be used.

[0036] Embodiments of the invention have been described to explain the nature of the invention. Those skilled in the art may make changes in the details, materials, steps and arrangement of the described embodiments within the principle and scope of the invention, as expressed in the appended claims.

REFERENCE LIST

- [0037]** 1. Roach, R. C., et al., *The Lake Louise Acute Mountain Sickness scoring system, in Hypoxia and Molecular Medicine*, J. R. Sutton, C. S. Houston, and G. Coates, Editors. 1993, Queen City Printers: Burlington. p. 272-274.
- [0038]** 2. Hackett, P. H. and R. C. Roach, *High altitude illness*. N. Engl. J. Med, 2001. 345(2): p. 107-114.
- [0039]** 3. Beidleman, B. A., et al., *Predictive models of acute mountain sickness after rapid ascent to various altitudes*. Med. Sci. Sports Exerc, 2013. 45(4): p. 792-800.
- [0040]** 4. Hackett, P. H., D. Rennie, and H. D. Levine, *The incidence, importance, and prophylaxis of acute mountain sickness*. Lancet, 1976. 2(7996): p. 1149-1154.
- [0041]** 5. Roach, R., J. Stapanek, and P. Hackett, *Acute mountain sickness and high-altitude cerebral edema, in Medical Aspects of Harsh Environments, Volume 2*, K. B. Pandolf and R. E. Burr, Editors. 2002, Associated Press: New York. p. 765-793.
- [0042]** 6. Maher, J. T., L. G. Jones, and L. H. Hartley, *Effects of high altitude exposure on submaximal endurance capacity of man*. J. Appl. Physiol, 1974. 37(6): p. 895-898.
- [0043]** 7. Horstman, D., R. Weiskopf, and R. E. Jackson, *Work capacity during 3-wk sojourn at 4,300 m: effects of relative polycythemia*. J. Appl. Physiol, 1980. 49(2): p. 311-318.
- [0044]** 8. Fulco, C. S., et al., *Carbohydrate supplementation improves cycle time-trial performance during energy deficit at 4,300-m altitude*. J. Appl. Physiol, 2005. 99(3): p. 867-876.
- [0045]** 9. Beidleman, B. A., et al., *Quantitative model of sustained physical task duration at varying altitudes*. Med. Sci. Sports Exerc, 2015. September 3((epub ahead of print)).

- [0046] 10. Fulco, C. S. and A. Cymerman, *Physical performance at varying terrestrial altitudes*, in *Medical Aspects of Harsh Environments, Volume 2*, D. E. Lounsbury, R. F. Bellamy, and R. Zatchuk, Editors. 2002, Borden Institute: Washington, D.C. p. 693-728.
- [0047] 11. Subudhi, A. W., et al., *AltitudeOmics: The integrative physiology of human acclimatization to hypobaric hypoxia and its retention upon reascent*. *PLoS One*, 2014. 9(3): p. e92191.
- [0048] 12. Kryskow, M. A., et al., *Performance during simple and complex military psychomotor tasks at various altitudes*. *Aviat. Space Environ. Med*, 2013. 84(9): p. 1-6.
- [0049] 13. Beidleman, B. A., et al., *Is normobaric hypoxia an effective treatment for sustaining previously acquired altitude acclimatization*. *J. Appl. Physiol*, 2017. 123: p. 1214-1227.
- [0050] 14. Banderet, L. E. and B. Shukitt-Hale, *Cognitive performance, mood, and neurological status at high terrestrial elevations*, in *Medical aspects of harsh environments*, D. E. Lounsbury, R. F. Bellamy, and R. Zajchuk, Editors. 2002, Office of the Surgeon General: Washington, D. C. p. 729-763.
- [0051] 15. Beidleman, B. A., et al., *Quantitative Model of Sustained Physical Task Performance at Varying Altitudes*. *Med. Sci. Sports Exerc.*, 2015. 48: p. 323-30.
- [0052] 16. Beidleman, B. A., A. P. Welles, and M. J. Buller, *Predicting individual risk of altitude illness using real-time monitoring of accumulated hypoxic debt*. *J. Sci. Med. Sport*, 2017. 20: p. S94-S95.

What is claimed is:

1. A method for real-time monitoring of an individual, comprising:

- (a) providing a pulse arterial oxygen saturation (SpO₂) sensor and a portable computing device to an individual;
- (b) using the sensor, measuring the SpO₂ value of the individual in real-time once a second;
- (c) using a processor in the computing device, obtaining an average real-time SpO₂ value over a time interval between 1 and 60 seconds;
- (d) using the processor, subtracting the average real-time SpO₂ value from 90% to obtain a real-time SpO₂ difference;
- (e) using the processor, multiplying the real-time SpO₂ difference by the time interval and converting the product to % hours to obtain a real-time hypoxic debt value;
- (f) storing the real-time hypoxic debt value in a memory of the computing device;
- (g) repeating steps (b)-(f) for a plurality of the time intervals;
- (h) using the processor, retrieving a plurality of stored real-time hypoxic debt values from the memory;
- (i) using the processor, summing the plurality of retrieved real-time hypoxic debt values to obtain accumulated hypoxic debt (AHD);
- (j) using the processor, calculating a probability (D) of experiencing acute mountain sickness as $D=e^{-1.94+0.017(AHD)/1+e^{-1.94+0.017(AHD)}}$; and
- (k) using an output device, communicating the probability D to the individual.

2. The method of claim 1, wherein step (b) includes measuring the SpO₂ value of the individual in real-time when the individual is located above an altitude of about 2500 meters.

3. The method of claim 1, wherein step (c) includes using the processor to obtain an average real-time SpO₂ value over a time interval of 15 seconds.

4. The method of claim 3, wherein step (e) includes using the processor to multiply the real-time SpO₂ difference by the time interval of 15 seconds and converting the product to % hours to obtain a real-time hypoxic debt value.

5. The method of claim 4, wherein step (g) includes repeating steps (b)-(f) for a plurality of the 15 second time intervals.

6. The method of claim 5, wherein steps (b)-(k) are repeated over a period of 48 hours.

7. The method of claim 1, wherein step (k) includes communicating the probability D to the individual using a visual display.

8. The method of claim 7, wherein step (k) includes using the output device to communicate a course of action to the individual.

9. The method of claim 8, wherein step (k) includes communicating one or more of the probability D and the course of action in one or more of a numerical format, a color-coded format and a format using words.

10. A method for real-time monitoring of an individual, comprising:

- (a) providing a pulse arterial oxygen saturation (SpO₂) sensor and a portable computing device to an individual;
- (b) using the sensor, measuring the SpO₂ value of the individual in real-time once a second when the individual is located above an altitude of about 2500 meters;
- (c) using a processor in the computing device, obtaining an average real-time SpO₂ value over a 15 second time interval;
- (d) using the processor, subtracting the average real-time SpO₂ value from 90% to obtain a real-time SpO₂ difference;
- (e) using the processor, multiplying the real-time SpO₂ difference by the time period of 15 seconds and converting the product to % hours to obtain a real-time hypoxic debt value;
- (f) storing the real-time hypoxic debt value in a memory of the computing device;
- (g) repeating steps (b)-(f) for a plurality of 15 second intervals;
- (h) using the processor, retrieving a plurality of stored real-time hypoxic debt values from the memory;
- (i) using the processor, summing the plurality of retrieved real-time hypoxic debt values to obtain accumulated hypoxic debt (AHD);
- (j) using the processor, calculating a probability (D) of experiencing acute mountain sickness as $D=e^{-1.94+0.017(AHD)/1+e^{-1.94+0.017(AHD)}}$; and
- (k) using an output device, communicating the probability D to the individual.

11. A non-transitory computer-readable medium with instructions stored thereon that, when executed by a processor, a memory, a pulse arterial oxygen saturation (SpO₂) sensor, and an output device, perform the steps comprising steps (b)-(k) of claim 1.

12. A non-transitory computer-readable medium with instructions stored thereon that, when executed by a processor, a memory, a pulse arterial oxygen saturation (SpO₂) sensor, and an output device, perform the steps comprising steps (b)-(k) of claim 10.

13. A system for real-time monitoring of an individual for a risk of Acute Mountain Sickness, comprising:

- a pulse arterial oxygen saturation (SpO₂) sensor configured to extract SpO₂ measurements from the individual;
- a portable computing device configured to be worn or carried by the individual and connected to the SpO₂ sensor;
- the portable computing device include a processor, a memory, and an output device;

wherein the processor is configured to (a) obtain an average real-time SpO₂ value over a 15 second time interval; (b) subtract the average real-time SpO₂ value from 90% to obtain a real-time SpO₂ difference; (c) multiply the real-time SpO₂ difference by the time period of 15 seconds and convert the product to % hours to obtain a real-time hypoxic debt value; (d) store

the real-time hypoxic debt value in the memory of the computing device; (e) retrieve a plurality of stored real-time hypoxic debt values from the memory; (f) sum the plurality of retrieved real-time hypoxic debt values to obtain accumulated hypoxic debt (AHD); (g) calculate a probability (D) of experiencing acute mountain sickness as $D = \frac{e^{-1.94+0.017(AHD)}}{1+e^{-1.94+0.017(AHD)}}$; and (h) communicate the probability D to the individual by sending the probability D to the output device.

14. A method of detecting Acute Mountain Sickness (AMS) in a human, comprising:

- obtaining SpO₂ measurements from the human;
- detecting whether the human is at risk of AMS by transforming the SpO₂ measurements to accumulated hypoxic debt (AHD); and
- using the AHD as an independent variable in a longitudinal generalized linear mixed model to calculate the probability D that the human is at risk of AMS.

15. The method of claim 14, wherein the probability D equals $e^{-1.94+0.017(AHD)}/1+e^{-1.94+0.017(AHD)}$.

* * * * *

专利名称(译)	潜在低氧困扰受试者的监测系统和方法		
公开(公告)号	US20200146602A1	公开(公告)日	2020-05-14
申请号	US16/628158	申请日	2018-12-08
申请(专利权)人(译)	美国政府称, 为代表陆军部长		
当前申请(专利权)人(译)	美国政府称, 为代表陆军部长		
发明人	BEIDLEMAN, BETH BULLER, MARK WELLES, ALEXANDER		
IPC分类号	A61B5/1455 A61B5/00 A61B5/02 A61B5/08 A61B5/11 A61B5/22 A61M16/12		
CPC分类号	A61B5/11 A61B5/08 A61B5/22 A61M16/12 A61B5/02 A61B5/4023 A61B5/14551 A61B5/7275 G16H50/30		
优先权	62/596511 2017-12-08 US		
外部链接	Espacenet USPTO		

摘要(译)

监视受试者的急性山病 (AMS) 风险的方法包括从受试者获得实时脉搏动脉血氧饱和度 (SpO2) 测量值。 SpO2 的测量值被转换为一种新颖的度量标准, 称为累积缺氧债务 (AHD)。 在纵向广义线性混合模型中, AHD度量用作自变量, 以计算对象处于AMS风险中的概率D。 基于概率D, 可以通过可穿戴或便携式监视器的输出设备将适当的动作过程传达给受试者。

