



(19) **United States**

(12) **Patent Application Publication**
Misener et al.

(10) **Pub. No.: US 2019/0320982 A1**
(43) **Pub. Date: Oct. 24, 2019**

(54) **CONNECTOR INTERFACE FOR ECG-BASED CATHETER POSITIONING SYSTEM**

(71) Applicant: **C. R. Bard, Inc.**, Murray Hill, NJ (US)

(72) Inventors: **Anthony K. Misener**, Bountiful, UT (US); **Zachary S. Davis**, Sandy, UT (US); **Jason R. Stats**, Layton, UT (US)

(21) Appl. No.: **16/457,606**

(22) Filed: **Jun. 28, 2019**

Related U.S. Application Data

(63) Continuation of application No. 15/192,561, filed on Jun. 24, 2016, now Pat. No. 10,349,890.

(60) Provisional application No. 62/185,477, filed on Jun. 26, 2015.

Publication Classification

(51) **Int. Cl.**
A61B 5/00 (2006.01)
A61B 5/06 (2006.01)
A61M 25/01 (2006.01)
A61B 5/0404 (2006.01)
A61B 5/042 (2006.01)

(52) **U.S. Cl.**
CPC *A61B 5/6852* (2013.01); *A61B 5/062* (2013.01); *A61M 25/01* (2013.01); *A61B 2562/227* (2013.01); *A61B 5/042* (2013.01); *A61M 2230/04* (2013.01); *A61B 5/0404* (2013.01)

(57) **ABSTRACT**

A connector interface configured to enable component inter-connection with a location sensor of a catheter placement system is disclosed. The catheter placement system is configured to assist a clinician in positioning a catheter in a desired location within a body of a patient. In one embodiment, the location sensor assembly comprises a location sensor body for temporary placement on a portion of the patient body, and a connector interface. The connector interface is configured to removably attach to the location sensor and provide a plurality of electrically conductive pathways between the location sensor and additional components of the catheter placement system to enable the additional components to operably connect with the location sensor. The connector interface further includes a first connector configured to operably connect with a second connector of one of the additional components of the catheter placement system through a drape interposed between the first and second connectors.

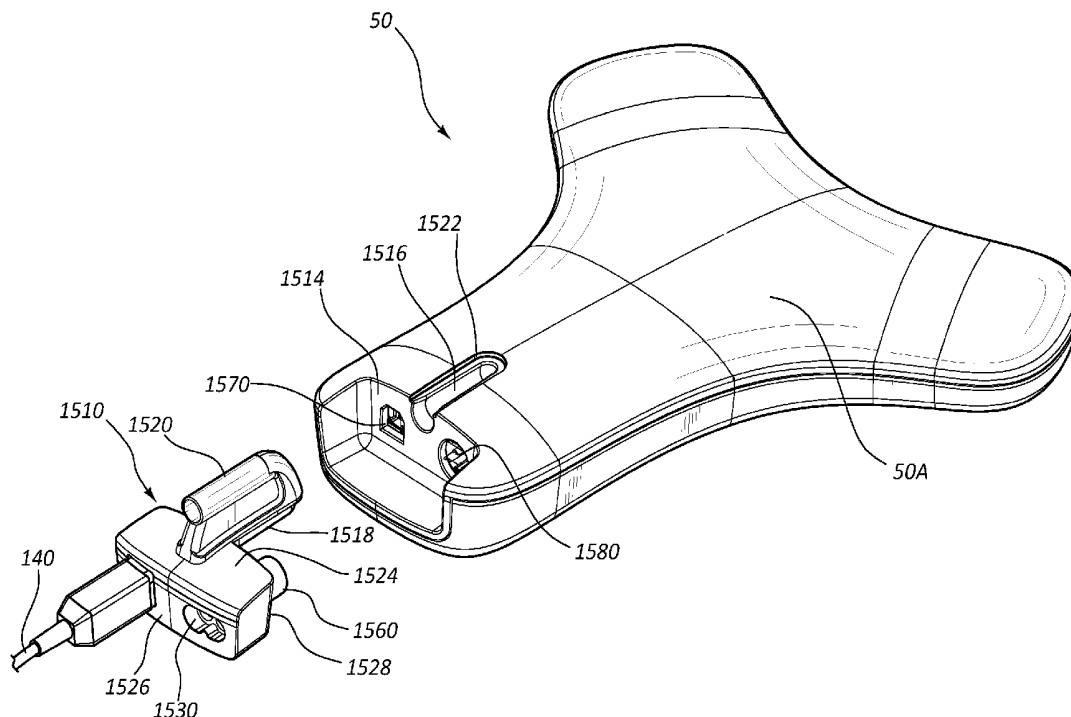

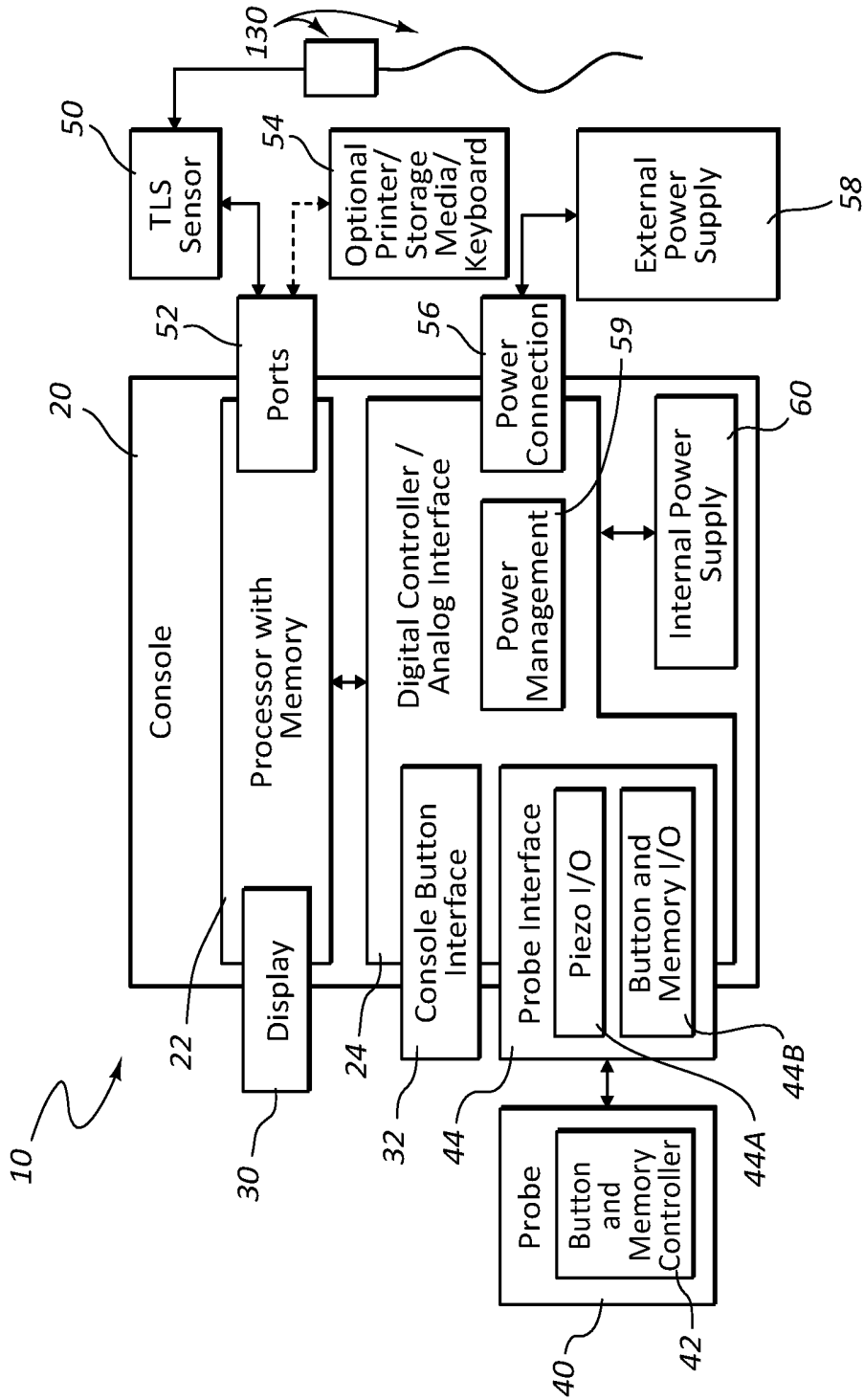

FIG. 1

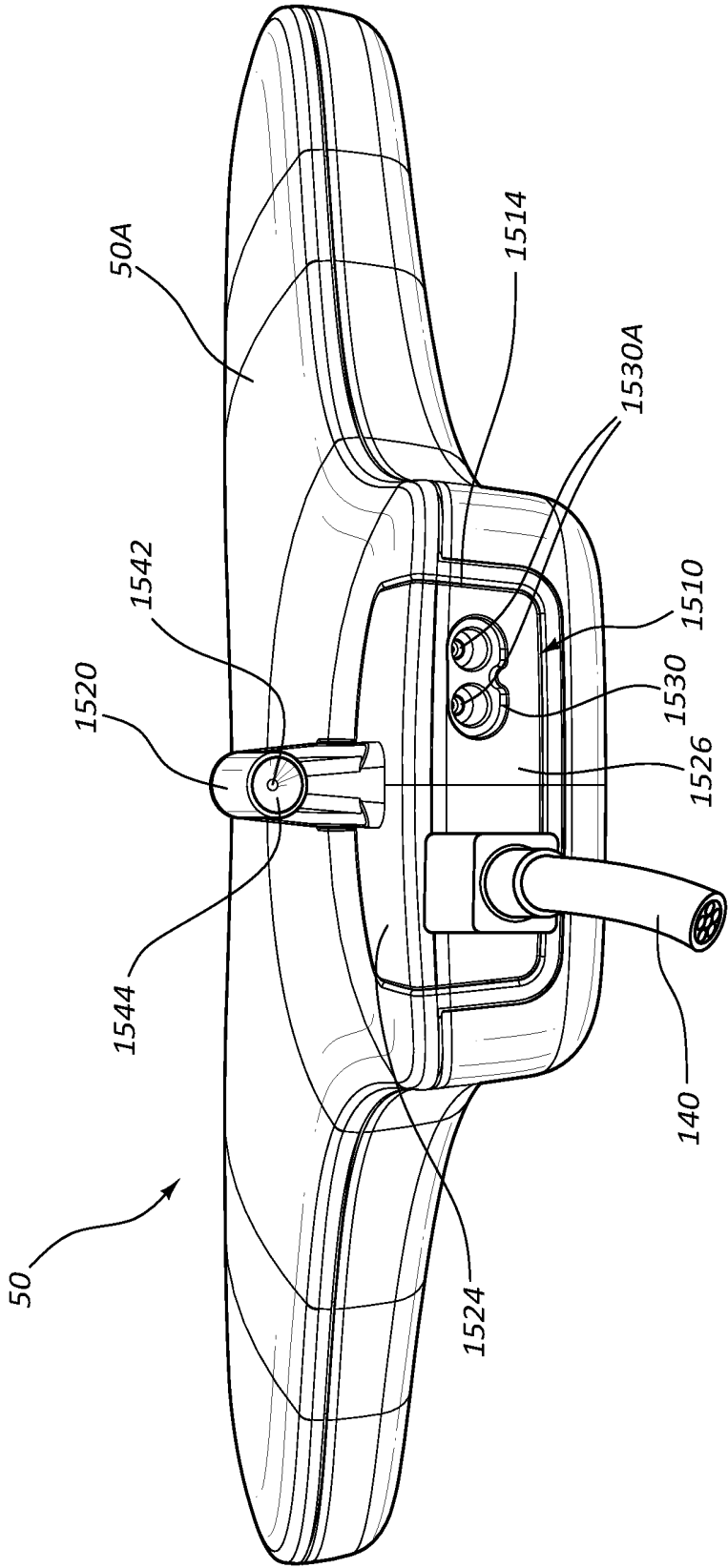
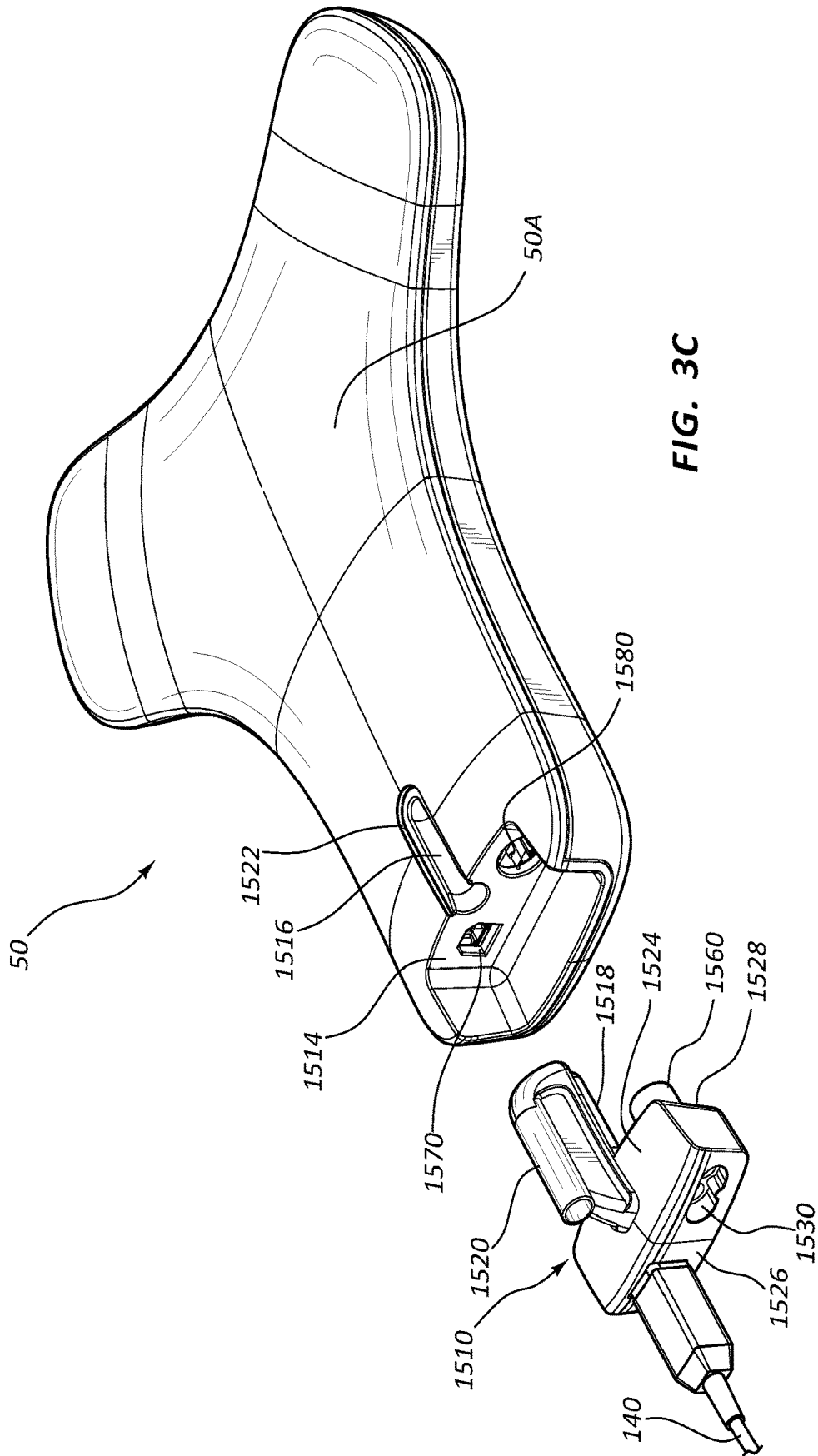

FIG. 3B



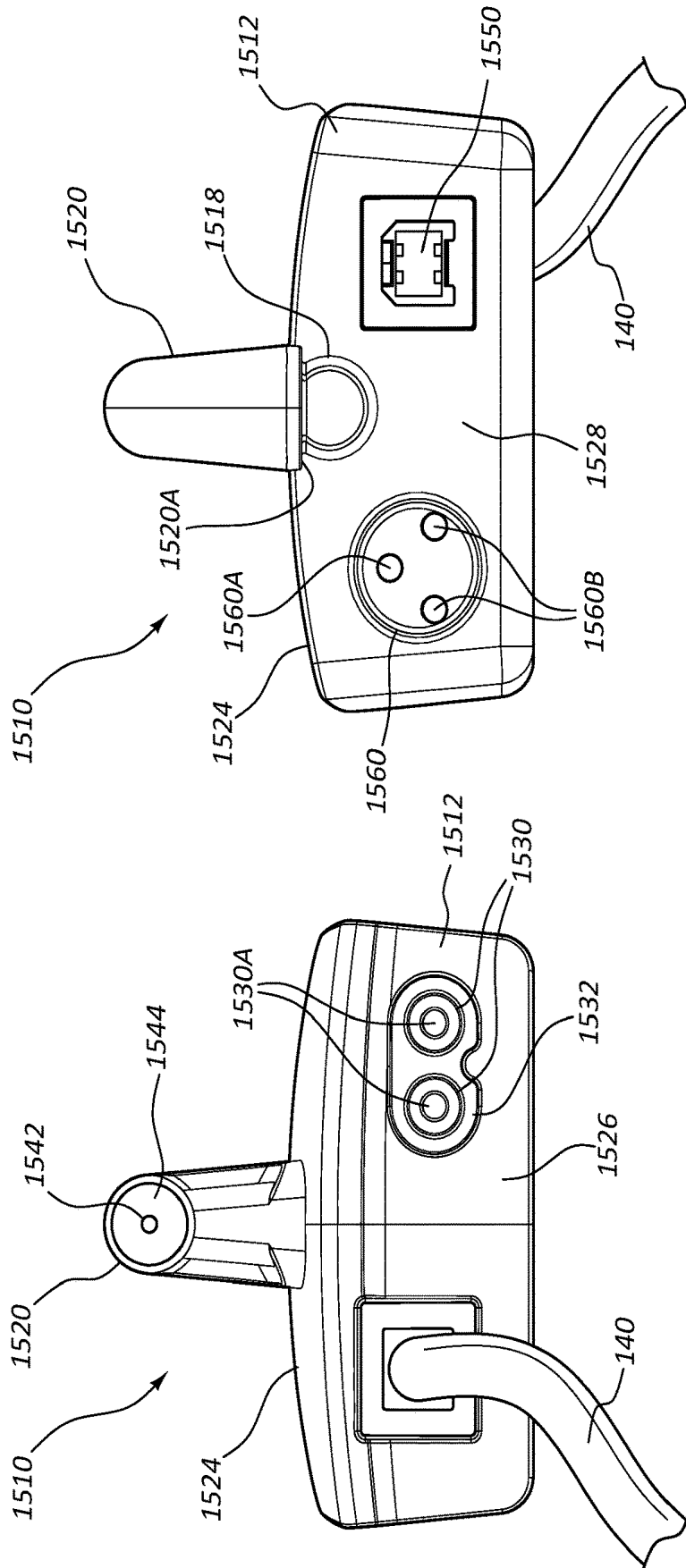

FIG. 4B

FIG. 4A

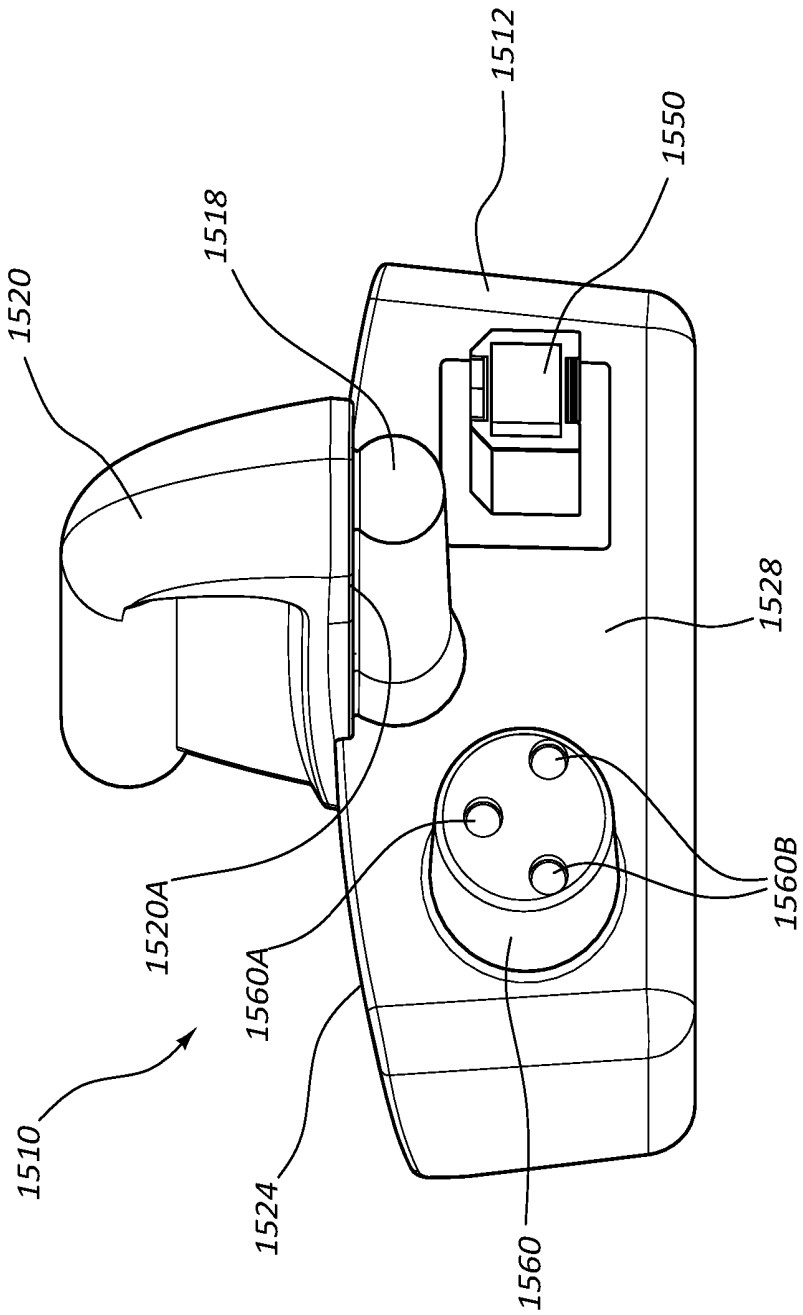

FIG. 4C

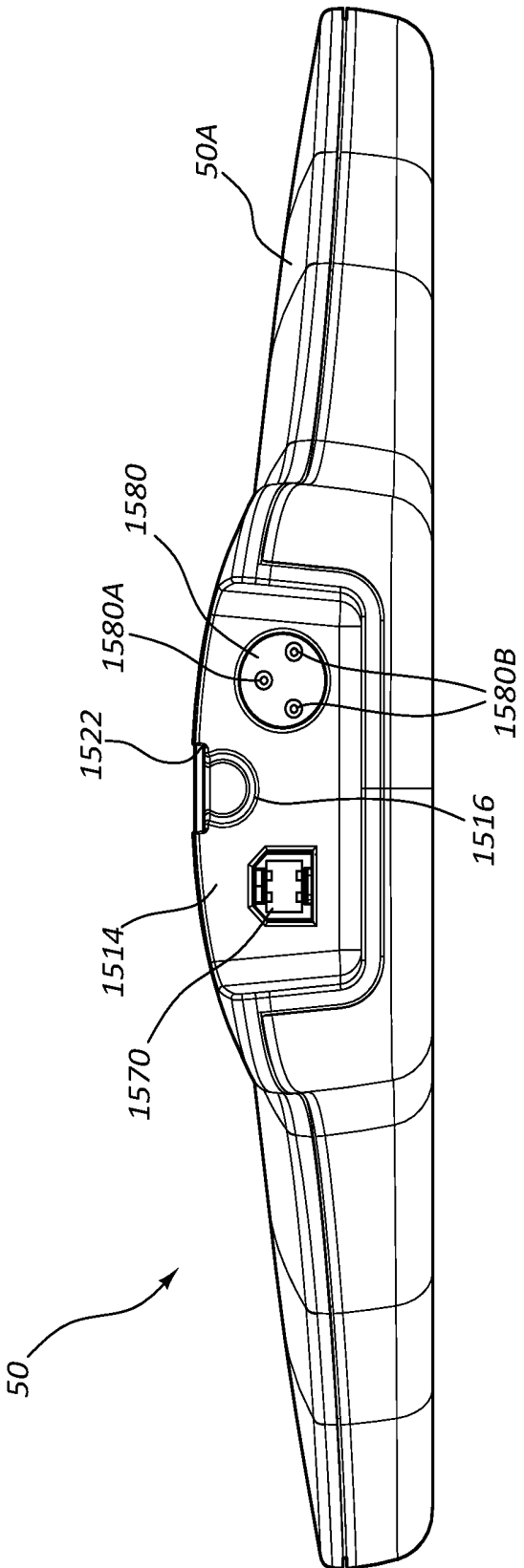

FIG. 5

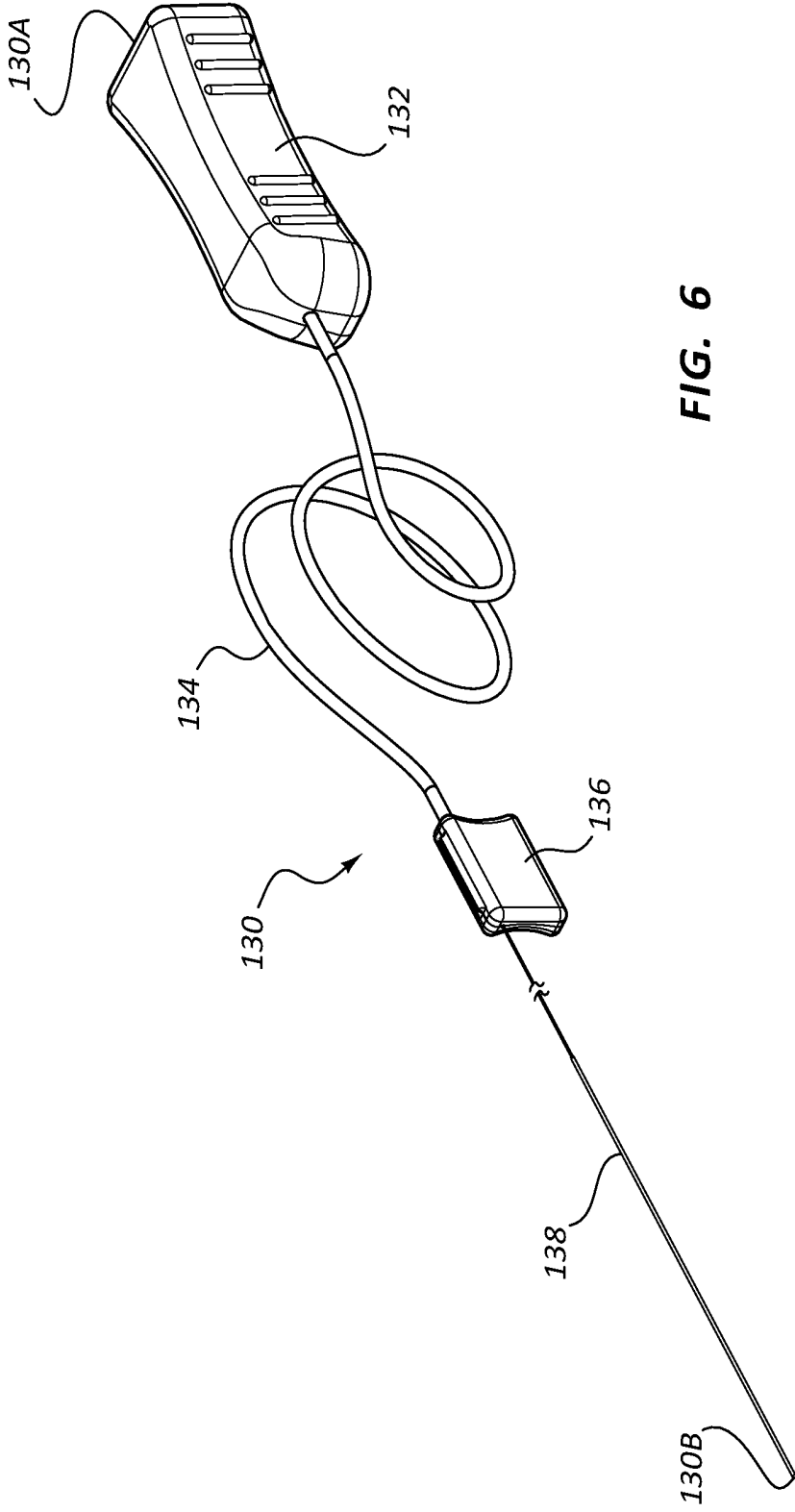

FIG. 6

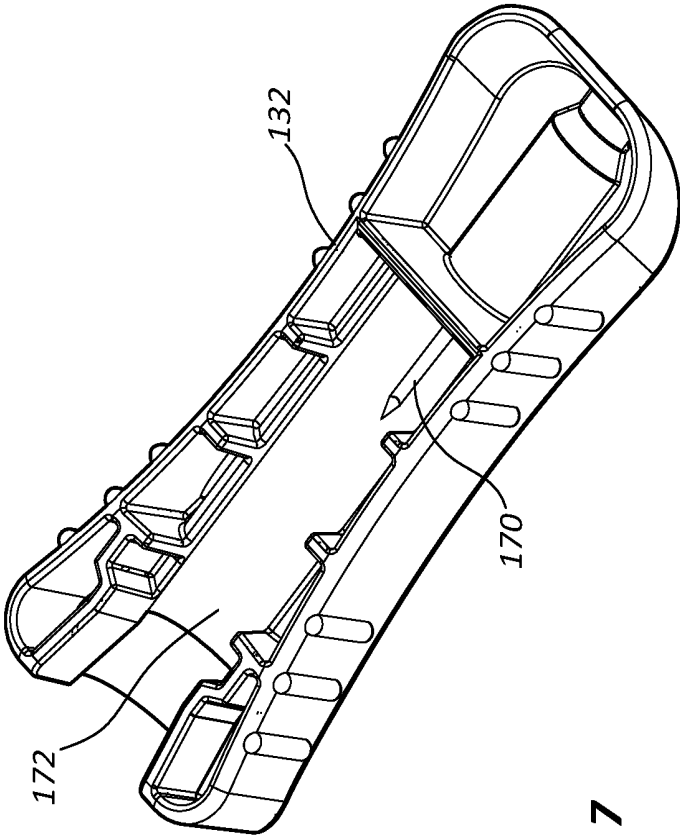
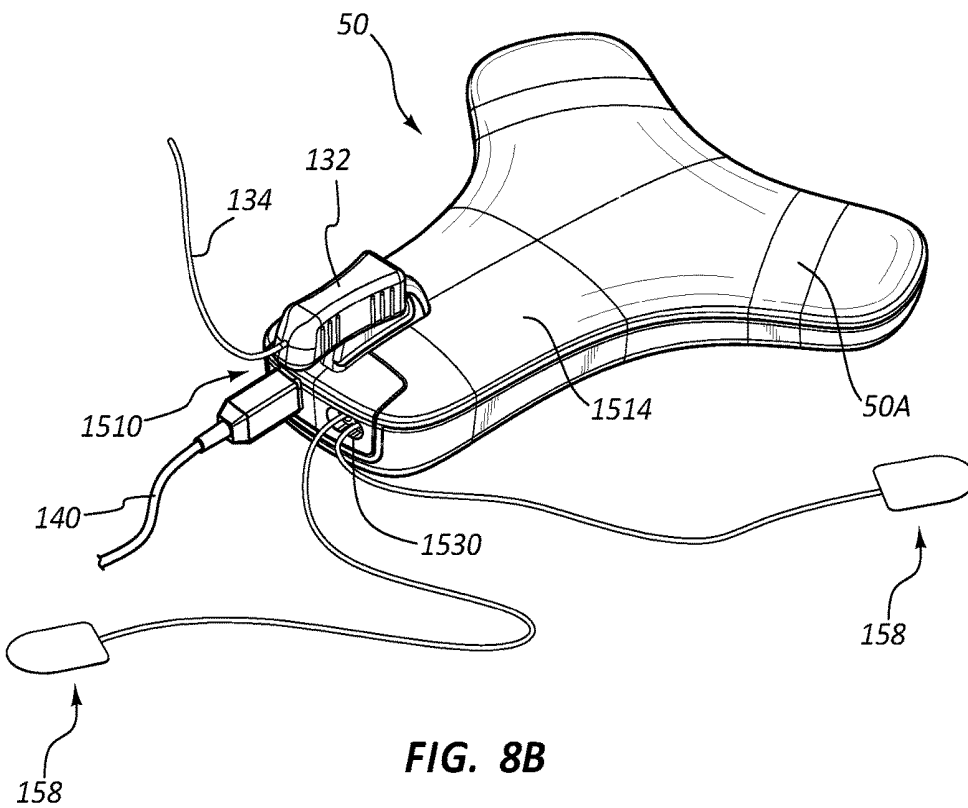
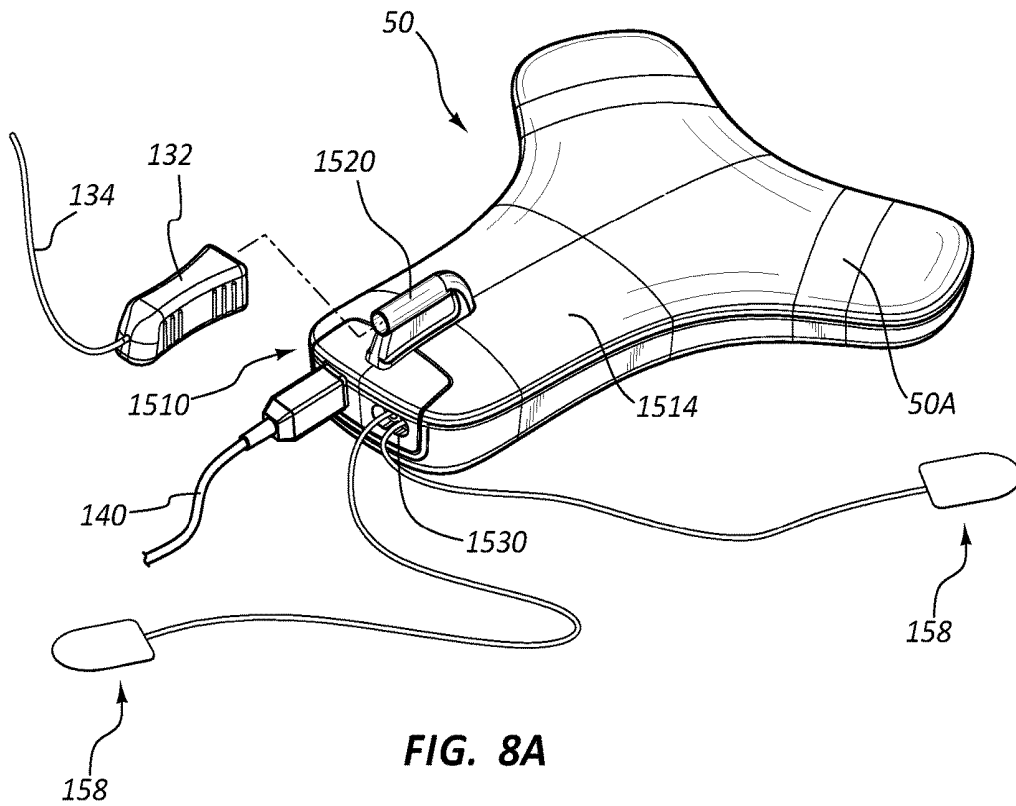

FIG. 7



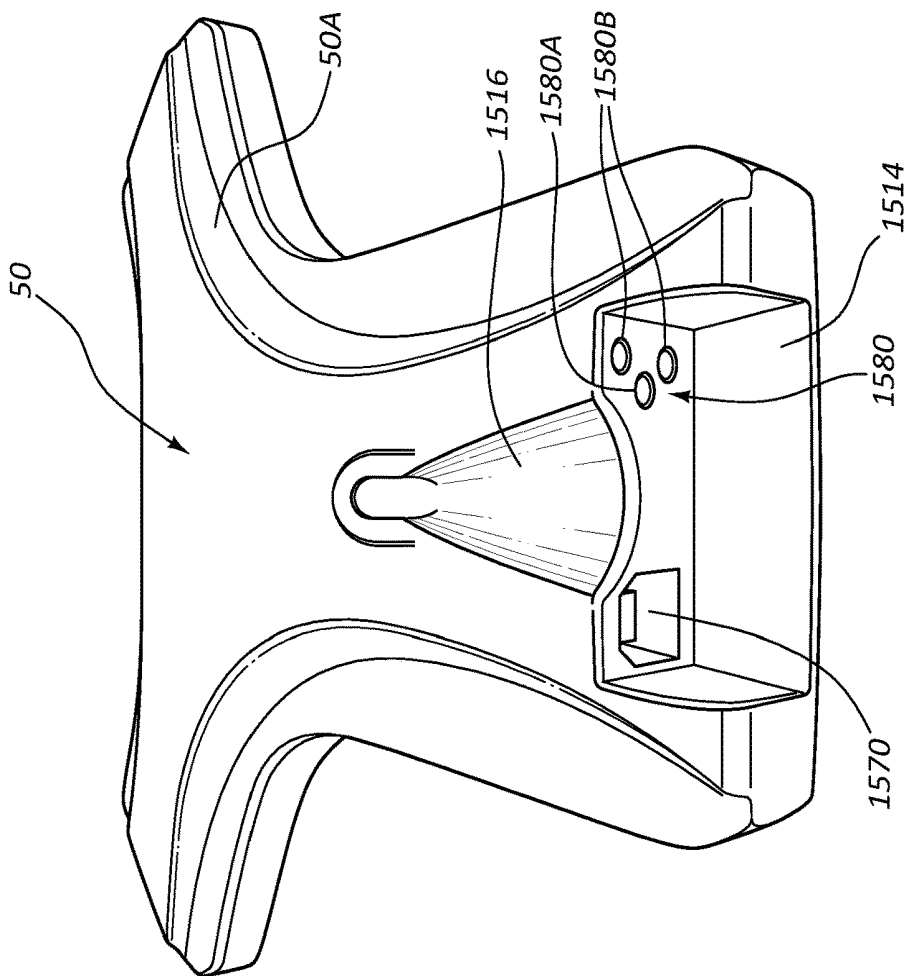

FIG. 9

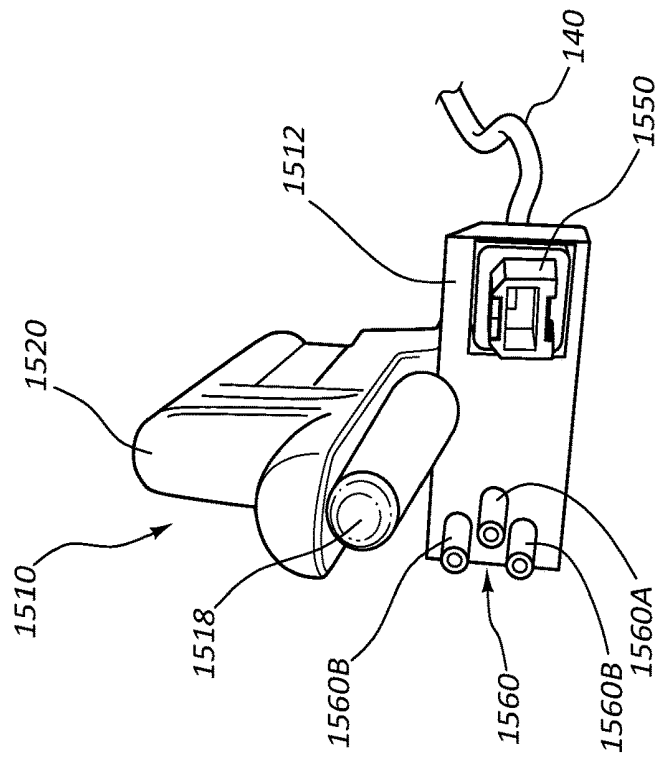

FIG. 10

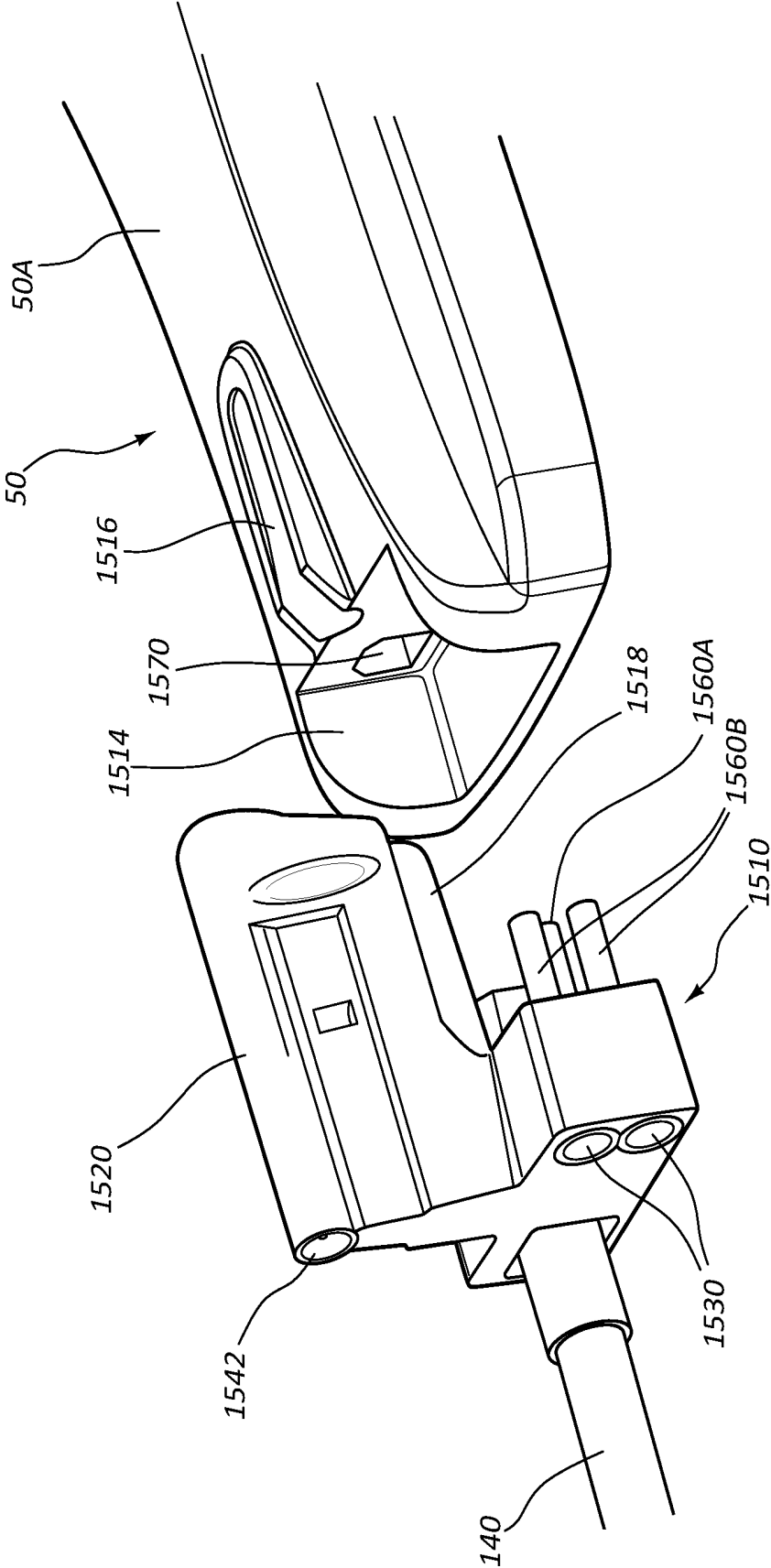

FIG. 11

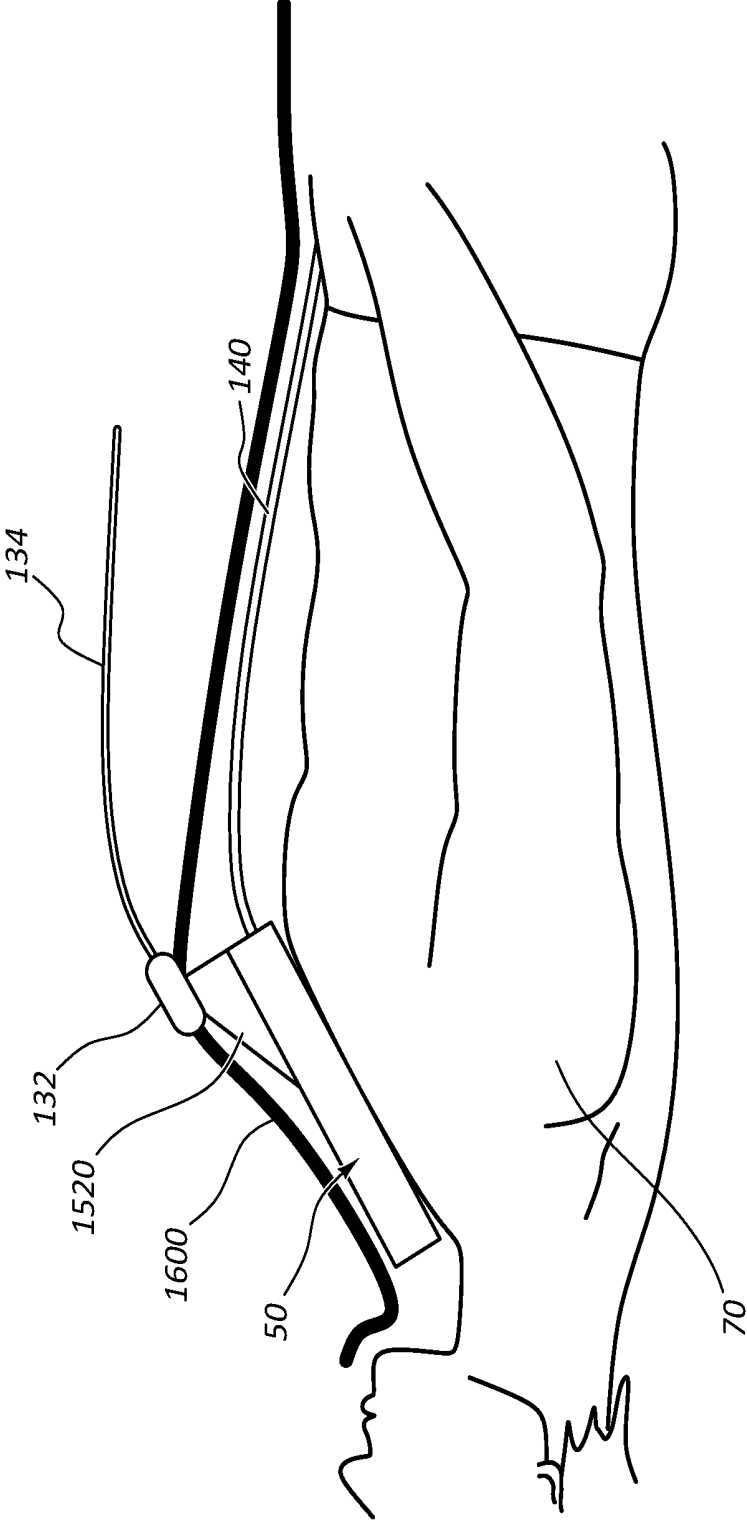

FIG. 12

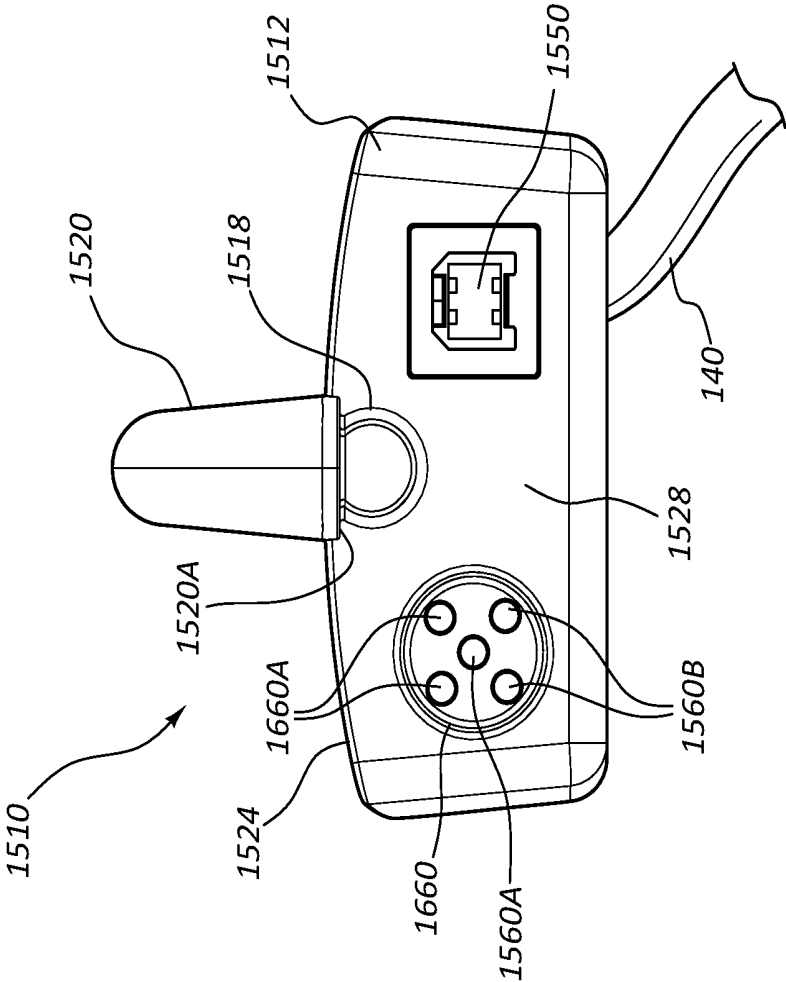

FIG. 13

CONNECTOR INTERFACE FOR ECG-BASED CATHETER POSITIONING SYSTEM

CROSS-REFERENCE TO RELATED APPLICATIONS

[0001] This application is a continuation of U.S. patent application Ser. No. 15/192,561, filed Jun. 24, 2016, now U.S. Pat. No. 10,349,890, which claims the benefit of U.S. Provisional Application No. 62/185,477, filed Jun. 26, 2015, and titled “Interface Connector for ECG-based Catheter Positioning System,” each of which is incorporated herein by reference in its entirety.

BRIEF SUMMARY

[0002] Briefly summarized, embodiments of the present invention are directed to a connector interface that is configured to enable component interconnection with a location sensor of a catheter placement system. The catheter placement system is configured to assist a clinician in positioning a catheter in a desired location within a body of a patient, such as a lower $\frac{1}{3}^{rd}$ portion of the superior vena cava within the patient’s vasculature.

[0003] In one embodiment, the location sensor assembly comprises a location sensor body for temporary placement on a portion of the patient body, and a connector interface. The connector interface is configured to removably attach to the location sensor and provide a plurality of electrically conductive pathways between the location sensor and additional components of the catheter placement system to enable the additional components to operably connect with the location sensor. The connector interface further includes a first connector configured to operably connect with a second connector of one of the additional components of the catheter placement system through a sterile barrier, such as a surgical drape, interposed between the first and second connectors.

[0004] These and other features of embodiments of the present invention will become more fully apparent from the following description and appended claims, or may be learned by the practice of embodiments of the invention as set forth hereinafter.

BRIEF DESCRIPTION OF THE DRAWINGS

[0005] A more particular description of the present disclosure will be rendered by reference to specific embodiments thereof that are illustrated in the appended drawings. It is appreciated that these drawings depict only typical embodiments of the invention and are therefore not to be considered limiting of its scope. Example embodiments of the invention will be described and explained with additional specificity and detail through the use of the accompanying drawings in which:

[0006] FIG. 1 is a block diagram of a catheter placement system according to one embodiment;

[0007] FIG. 2 is a simplified view of a patient and the catheter placement system of FIG. 1;

[0008] FIGS. 3A-3C depict various views of a location sensor of the catheter placement system of FIGS. 1 and 2;

[0009] FIGS. 4A-4C depict various views of a connector interface of the location sensor or FIGS. 3A-3C;

[0010] FIG. 5 is an end view of the location sensor of FIGS. 3A-3C;

[0011] FIG. 6 is a perspective view of a stylet of the catheter placement system of FIGS. 1 and 2;

[0012] FIG. 7 is a perspective view of a tether connector of the stylet of FIG. 6;

[0013] FIGS. 8A and 8B depict various views of the connection of the tether connector of FIG. 6 with the location sensor of FIGS. 3A-3C;

[0014] FIG. 9 is a perspective view of a location sensor according to one embodiment;

[0015] FIG. 10 is a perspective view of a connector interface for attachment to the location sensor of FIG. 9;

[0016] FIG. 11 depicts attachment of the connector interface of FIG. 10 with the location sensor of FIG. 9;

[0017] FIG. 12 shows a side view of a patient with the location sensor of FIG. 8B placed on the patient; and

[0018] FIG. 13 is an end view of a connector interface according to one embodiment.

DETAILED DESCRIPTION OF SELECTED EMBODIMENTS

[0019] Reference will now be made to figures wherein like structures will be provided with like reference designations. It is understood that the drawings are diagrammatic and schematic representations of exemplary embodiments of the present invention, and are neither limiting nor necessarily drawn to scale.

[0020] For clarity it is to be understood that the word “proximal” refers to a direction relatively closer to a clinician using the device to be described herein, while the word “distal” refers to a direction relatively further from the clinician. For example, the end of a catheter placed within the body of a patient is considered a distal end of the catheter, while the catheter end remaining outside the body is a proximal end of the catheter. Also, the words “including,” “has,” and “having,” as used herein, including the claims, shall have the same meaning as the word “comprising.”

[0021] Embodiments of the present disclosure are generally directed to a connector interface connector for use in interconnecting various elements of a catheter placement system. Use of the present interface connector enables various components of the catheter placement system to be replaced or interchanged while enabling other components to remain. This in turn reduces system cost and allows for a modular system design.

[0022] FIGS. 1 and 2 depict various details of a catheter placement system (“system” or “placement system”), generally designated at 10, which serves as one example environment wherein embodiments of the present disclosure can be practiced. The system 10 is employed to assist a clinician in the placement of a catheter or other medical device within the body of a patient, such as within the vasculature. In one embodiment, the system 10 enables a distal tip of a catheter to be placed within the patient vasculature in desired proximity to the heart using ECG signals produced by the patient’s heart. In one embodiment, the medical device includes a catheter and the intended destination of the catheter within the patient body is such that the distal tip of the catheter is disposed in the lower $\frac{1}{3}^{rd}$ portion of the superior vena cava (“SVC”). The guidance and placement system analyzes the ECG signals of the patient to determine when the catheter has reached its intended destination within the vasculature, then notifies the clinician via a display, for

instance. Thus, the system includes an ECG modality for assisting in medical device placement within the patient.

[0023] In one embodiment, the above-referenced ECG guidance modality of the system 10 is accompanied by an ultrasound (“US”) modality to assist with initial insertion of the medical device into the body, and a magnetic element-based tracking, or tip location system (“TLS”) modality to track the position and orientation of the medical device as it advances toward its intended destination.

[0024] As mentioned, FIGS. 1 and 2 depict various components of the system 10 in accordance with one example embodiment. As shown, the system 10 generally includes a console 20, display 30, probe 40, and sensor 50, each of which is described in further detail below.

[0025] FIG. 2 shows the general relation of these components to a patient 70 during a procedure to place a catheter 72 into the patient vasculature through a skin insertion site 73. FIG. 2 shows that the catheter 72 generally includes a proximal portion 74 that remains exterior to the patient and a distal portion 76 that resides within the patient vasculature after placement is complete. In the present embodiment, the system 10 is employed to ultimately position a distal tip 76A of the catheter 72 in a desired position within the patient vasculature. In one embodiment, the desired position for the catheter distal tip 76A is proximate the patient’s heart, such as in the lower one-third ($\frac{1}{3}^{rd}$) portion of the Superior Vena Cava (“SVC”). Of course, the system 10 can be employed to place the catheter distal tip in other locations. The catheter proximal portion 74 further includes a bifurcation hub 74A that provides fluid communication between the one or more lumens of the catheter 72, one or more extension tubes 74B extending proximally from the hub, and corresponding connectors 74C for enabling connection to the catheter 72.

[0026] A processor 22, including non-volatile memory such as EEPROM for instance, is included in the console 20 for controlling system function during operation of the system 10, thus acting as a control processor. A digital controller/analog interface 24 is also included with the console 20 and is in communication with both the processor 22 and other system components to govern interfacing between the probe 40, sensor 50, and other system components.

[0027] The system 10 further includes ports 52 for connection with the sensor 50 and optional components 54 including a printer, storage media, keyboard, etc. The ports in one embodiment are USB ports, though other port types or a combination of port types can be used for this and the other interfaces connections described herein. A power connection 56 is included with the console 20 to enable operable connection to an external power supply 58. An internal battery 60 can also be employed, either with or exclusive of an external power supply. Power management circuitry 59 is included with the digital controller/analog interface 24 of the console to regulate power use and distribution.

[0028] The display 30 in the present embodiment is integrated into the console 20 and is used to display information to the clinician during the catheter placement procedure. In another embodiment, the display may be separate from the console. As will be seen, the content depicted by the display 30 changes according to which mode the catheter placement system is in: US, TLS, or in other embodiments, ECG tip confirmation. In one embodiment, a console button interface 32 and buttons included on the probe 40 can be used to immediately call up a desired mode to the display 30 by the

clinician to assist in the placement procedure. In one embodiment, information from multiple modes, such as TLS and ECG, may be displayed simultaneously. Thus, the single display 30 of the system console 20 can be employed for ultrasound guidance in accessing a patient’s vasculature, TLS guidance during catheter advancement through the vasculature, and (as in later embodiments) ECG-based confirmation of catheter distal tip placement with respect to a node of the patient’s heart. In one embodiment, the display 30 is an LCD device.

[0029] The probe 40 is employed in connection with the first modality mentioned above, i.e., ultrasound (“US”)-based visualization of a vessel, such as a vein, in preparation for insertion of the catheter 72 into the vasculature. Such visualization gives real time ultrasound guidance for introducing the catheter into the vasculature of the patient and assists in reducing complications typically associated with such introduction, including inadvertent arterial puncture, hematoma, pneumothorax, etc.

[0030] As such, in one embodiment a clinician employs the first, US, modality to determine a suitable insertion site and establish vascular access, such as with a needle and introducer, then with the catheter. The clinician can then seamlessly switch, via button pushes on the probe button pad, to the second, TLS, modality without having to reach out of the sterile field. The TLS mode can then be used to assist in advancement of the catheter 72 through the vasculature toward an intended destination.

[0031] FIG. 1 shows that the probe 40 further includes button and memory controller 42 for governing button and probe operation. The button and memory controller 42 can include non-volatile memory, such as EEPROM, in one embodiment. The button and memory controller 42 is in operable communication with a probe interface 44 of the console 20, which includes a piezo input/output component 44A for interfacing with the probe piezoelectric array and a button and memory input/output component 44B for interfacing with the button and memory controller 42.

[0032] Note that while a vein is typically depicted on the display 30 during use of the system 10 in the US modality, other body lumens or portions can be imaged in other embodiments. Note that the US mode can be simultaneously depicted on the display 30 with other modes, such as the TLS mode or ECG mode, if desired. In addition to the visual display 30, aural information, such as beeps, tones, etc., or vibratory/motion-based cues can also be employed by the system 10 to assist the clinician during catheter placement. Moreover, the buttons included on the probe 40 and the console button interface 32 can be configured in a variety of ways, including the use of user input controls in addition to buttons, such as slide switches, toggle switches, electronic or touch-sensitive pads, etc. Additionally, US, TLS, and ECG activities can occur simultaneously or exclusively during use of the system 10.

[0033] As just described, the handheld ultrasound probe 40 is employed as part of the integrated catheter placement system 10 to enable US visualization of the peripheral vasculature of a patient in preparation for transcatheter introduction of the catheter. In the present example embodiment, however, the probe is also employed to control functionality of the TLS portion, or second modality, of the system 10 when navigating the catheter toward its desired destination within the vasculature as described below. Again, as the probe 40 is used within the sterile field of the

patient, this feature enables TLS functionality to be controlled entirely from within the sterile field. Thus the probe 40 is a dual-purpose device, enabling convenient control of both US and TLS functionality of the system 10 from the sterile field. In one embodiment, the probe can also be employed to control some or all ECG-related functionality, or third modality, of the catheter placement system 10, as described further below.

[0034] The catheter placement system 10 further includes the second modality mentioned above, i.e., the magnetically-based catheter TLS, or tip location system. The TLS enables the clinician to quickly locate and confirm the position and/or orientation of the catheter 72, such as a peripherally-inserted central catheter (“PICC”), central venous catheter (“CVC”), or other suitable catheter or medical device, during initial placement into and advancement through the vasculature of the patient 70. Specifically, the TLS modality detects a magnetic field generated by a magnetic element-equipped tip location stylet, which is pre-loaded in one embodiment into a longitudinally defined lumen of the catheter 72, thus enabling the clinician to ascertain the general location and orientation of the catheter tip within the patient body. In one embodiment, the magnetic assembly can be tracked using the teachings of one or more of the following U.S. Pat. Nos. 5,775,322; 5,879,297; 6,129,668; 6,216,028; and 6,263,230. The contents of the aforementioned U.S. patents are incorporated herein by reference in their entireties. The TLS also displays the direction in which the catheter tip is pointing, thus further assisting accurate catheter placement. The TLS further assists the clinician in determining when a malposition of the catheter tip has occurred, such as in the case where the tip has deviated from a desired venous path into another vein.

[0035] As mentioned, the TLS utilizes a stylet 130 to enable the distal end of the catheter 72 to be tracked during its advancement through the vasculature. In one embodiment and as shown in FIG. 6, the stylet 130 includes a proximal end 130A and a distal end 130B, with an included handle 136. A core wire 138 distally extends from the handle 136, and a tether 134 (for operably connecting the stylet 130 to the placement system 10) extends proximally from the handle. A magnetic assembly is disposed distally of the core wire 138. The magnetic assembly includes one or more magnetic elements disposed adjacent one another proximate the stylet distal end 130B and encapsulated by tubing. In the present embodiment, a plurality of magnetic elements is included, each element including a solid, cylindrically shaped ferromagnetic stacked end-to-end with the other magnetic elements. An adhesive tip can fill the distal tip of the tubing, distally to the magnetic elements.

[0036] Note that in other embodiments, the magnetic elements may vary from the design in not only shape, but also composition, number, size, magnetic type, and position in the stylet distal segment. For example, in one embodiment, the plurality of ferromagnetic magnetic elements is replaced with an electromagnetic assembly, such as an electromagnetic coil, which produces a magnetic field for detection by the sensor. Another example of an assembly usable here can be found in U.S. Pat. No. 5,099,845, entitled “Medical Instrument Location Means,” which is incorporated herein by reference in its entirety. Yet other examples of stylets including magnetic elements that can be employed with the TLS modality can be found in U.S. Pat. No. 8,784,336, entitled “Stylet Apparatuses and Methods of

Manufacture,” which is incorporated herein by reference in its entirety. These and other variations are therefore contemplated by embodiments of the present invention. It should be appreciated herein that “stylet” as used herein can include any one of a variety of devices configured for removable placement within a lumen of the catheter to assist in placing a distal end of the catheter in a desired location within the patient’s vasculature. In one embodiment, the stylet includes a guidewire. As such, it is appreciated that stylets of other forms and configurations can also be acceptably used, in accordance with the present disclosure.

[0037] FIG. 2 shows disposal of the stylet 130 substantially within a lumen in the catheter 72 such that the proximal portion thereof extends proximally from the catheter lumen, through the bifurcation hub 74A and out through a selected one of the extension tubes 74B. So disposed within a lumen of the catheter, the distal end 130B of the stylet 130 in the present embodiment is substantially co-terminal with the distal catheter end 76A such that detection by the TLS of the stylet distal end correspondingly indicates the location of the catheter distal end. In other embodiments, other positional relationships between the distal ends of the stylet and catheter or medical device are possible.

[0038] The TLS sensor 50 (also referred to herein as a “location sensor”) is employed by the system 10 during TLS operation to detect the magnetic field produced by the magnetic elements of the stylet 130. As seen in FIG. 2, the TLS sensor 50 is placed on the chest of the patient during catheter insertion. The TLS sensor 50 is positioned on the chest of the patient in a predetermined location, such as through the use of external body landmarks, to enable the magnetic field of the stylet magnetic elements, disposed in the catheter 72 as described above, to be detected during catheter transit through the patient vasculature. Again, as the magnetic elements of the stylet magnetic assembly are co-terminal with the distal end 76A of the catheter 72 in one embodiment (FIG. 2), detection by the TLS sensor 50 of the magnetic field of the magnetic elements provides information to the clinician as to the position and orientation of the catheter distal end during its transit.

[0039] In greater detail, the TLS sensor 50 is operably connected to the console 20 of the system 10 via a connection of a console cable 140 with one or more of the ports 52 of the console, as shown in FIG. 1. The console cable 140 attaches to the TLS sensor 50 in a manner to be described further below. Note that other connection schemes between the TLS sensor and the system console can also be used, without limitation. As just described, the magnetic elements are employed in the stylet 130 to enable the position of the catheter distal end 76A (FIG. 2) to be observable relative to the TLS sensor 50 placed on the patient’s chest. Detection by the TLS sensor 50 of the stylet magnetic elements is graphically displayed on the display 30 of the console 20 during TLS mode. In this way, a clinician placing the catheter is able to generally determine the location of the catheter distal end 76A within the patient vasculature relative to the TLS sensor 50 and detect when catheter malposition, such as advancement of the catheter along an undesired vein, is occurring.

[0040] As discussed above, the system 10 includes additional functionality in the present embodiment wherein determination of the proximity of the catheter distal tip 76A relative to a sino-atrial (“SA”) or other electrical impulse-emitting node of the heart of the patient 70 can be deter-

mined, thus providing enhanced ability to accurately place the catheter distal tip in a desired location proximate the node. Also referred to herein as “ECG” or “ECG-based tip confirmation,” this third modality of the system 10 enables detection of ECG signals from the SA node in order to place the catheter distal tip in a desired location within the patient vasculature. Note that the US, TLS, and ECG modalities are seamlessly combined in the present system 10, but can be employed in concert or individually to assist in catheter placement. In one embodiment, it is understood that the ECG modality as described herein can be included in a stand-alone system without the inclusion of the US and TLS modalities. Thus, the environments in which the embodiments herein are described are understood as merely example environments and are not considered limiting of the present disclosure.

[0041] As described, the catheter stylet 130 is removably predisposed within the lumen of the catheter 72 being inserted into the patient 70 via the insertion site 73. The stylet 130, in addition to including a magnetic assembly for the magnetically-based TLS modality, includes a sensing component, i.e., an internal, intravascular ECG sensor assembly, proximate its distal end and including a portion that is co-terminal with the distal end of the catheter tip for intravascularly sensing ECG signals produced by the SA node, in the present embodiment when the catheter 72 and accompanying stylet 130 are disposed within the patient vasculature. The intravascular ECG sensor assembly is also referred to herein as an internal or “intravascular ECG sensor component,” and the stylet 130 as an “ECG stylet.”

[0042] As mentioned, the stylet 130 includes the tether 134 extending from its proximal end 130A that operably connects to the TLS sensor 50 in a manner to be described below, though other connection schemes to the system 10 are contemplated. As will be described in further detail, the stylet tether 134 permits ECG signals detected by the ECG sensor assembly included on a distal portion of the stylet 130 to be conveyed to the TLS sensor 50 during confirmation of the catheter tip location as part of the ECG signal-based tip confirmation modality.

[0043] External reference and ground ECG electrodes 158 attach to the body of the patient 70 in the present embodiment and are operably attached to the TLS sensor 50 to provide an external baseline ECG signal to the system 10 and to enable the system to filter out high level electrical activity unrelated to the electrical activity of the SA node of the heart, thus enabling the ECG-based tip confirmation functionality. As shown, in the present embodiment, one external electrode 158 is placed on the patient skin proximate the upper right shoulder (“right arm” placement) while another external electrode is placed proximate the lower left abdomen (“left leg” placement). This electrode arrangement provides a lead II configuration according to Einthoven’s triangle of electrocardiography. Operable attachment of the external electrodes 158 with the sensor 50 in a manner to be described below enables the ECG signals detected by the external electrodes to be conveyed to the console 20 of the system 10 or to another suitable destination. As such, the external electrodes 158 serve as one example of an external ECG sensor component. Other external sensors for detecting a baseline ECG signal external to the patient body can also be employed in other embodiments. In addition, other electrode locations are also possible.

[0044] Together with the external ECG signal received from the external ECG sensor component (i.e., the external ECG electrodes 158 placed on the patient’s skin), an internal, intravascular ECG signal sensed by the internal ECG sensor component (i.e., the stylet ECG sensor assembly of the stylet 130), is received by the TLS sensor 50 positioned on the patient’s chest (FIG. 10) or other designated component of the system 10. The TLS sensor 50 and/or console processor 22 can process the external and internal ECG signal data to produce one or more electrocardiogram traces, including a series of discrete ECG complexes, on the display 30, as will be described. In the case where the TLS sensor 50 processes the external and internal ECG signal data, a processor is included therein to perform the intended functionality. If the console 20 processes the ECG signal data, the processor 22, controller 24, or other processor can be utilized in the console to process the data.

[0045] Thus, as it is advanced through the patient vasculature, the catheter 72 equipped with the stylet 130 as described above can advance under the TLS sensor 50, which is positioned on the chest of the patient as shown in FIG. 10. This enables the TLS sensor 50 to detect the position of the magnetic assembly of the stylet 130 (described further above), which is substantially co-terminal with the distal tip 76A of the catheter as located within the patient’s vasculature. The detection by the TLS sensor 50 of the stylet magnetic assembly is depicted on the display 30 during ECG mode.

[0046] The display 30 can further depict during ECG mode one or more ECG electrocardiogram traces produced as a result of patient heart’s electrical activity as detected by the external and internal ECG sensor components described above. In greater detail, the ECG electrical activity of the SA node, including the P-wave of the trace, is detected by the external and internal sensor components and forwarded to the TLS sensor 50 and console 20. The ECG electrical activity is then processed for depiction on the display 30, as will be described further below.

[0047] A clinician placing the catheter can then observe the ECG data, which assists in determining optimum placement of the distal tip 76A of the catheter 72, such as proximate the SA node, for instance. In one embodiment, the console 20 includes the electronic components, such as the processor 22 (FIG. 1), necessary to receive and process the signals detected by the external and internal sensor components. In another embodiment, the TLS sensor 50 can include the necessary electronic components processing the ECG signals.

[0048] As already discussed, the display 30 is used to display information to the clinician during the catheter placement procedure. The content of the display 30 changes according to which mode the catheter placement system is in: US, TLS, or ECG. Any of the three modes can be immediately called up to the display 30 by the clinician, and in some cases information from multiple modes, such as TLS and ECG, may be displayed simultaneously. In one embodiment, as before, the mode the system is in may be controlled by the control buttons included on the handheld probe 40, thus eliminating the need for the clinician to reach out of the sterile field (such as touching the button interface 32 of the console 20) to change modes. Thus, in the present embodiment the probe 40 is employed to also control some or all ECG-related functionality of the system 10. Note that the button interface 32 or other input configurations can also

be used to control system functionality. Also, in addition to the visual display 30, aural information, such as beeps, tones, etc., can also be employed by the system to assist the clinician during catheter placement.

[0049] Note that further details regarding the system 10 can be found in U.S. Pat. No. 8,848,382, issued Sep. 30, 2014, and entitled “Apparatus and Display Methods Relating to Intravascular Placement of a Catheter,” which is incorporated herein by reference in its entirety. It is further noted that the above-described catheter placement system is but example of a variety of placement systems that can benefit from the principles of the embodiments described herein.

[0050] In view of the above discussion, reference is now made to FIGS. 3A-3C, which depict various details of the above-described TLS sensor 50, also referred to herein as a “location sensor.” In particular, the location sensor 50 includes a connector interface (“interface”) 1510 that is configured according to one embodiment. The interface 1510 is configured to enable interconnection of the location sensor 50 with various other catheter placement system components, including the ECG signal-sensing stylet 130 via the tether 134 (FIG. 6), the external ECG electrodes 158 (FIG. 2) via their respective lead wires (“leads”), and the console cable 140 that operably connects the location sensor with the console 20 of the system 10.

[0051] As shown, the interface 1510 includes a body 1512 that is configured to removably connect to the location sensor 50 within a pocket 1514 defined on a lower portion of the location sensor 50, from the perspective shown in FIG. 3A. The interface body 1512 includes a rail 1518 defined on a fin 1520 that is configured to be slidably received within a corresponding track 1516 defined on an outer surface 50A of the location sensor 50 proximate the pocket 1514, as shown in FIG. 3C. Other connective schemes can be employed in other embodiments. Also, the particular size, shape, and configuration of the interface 1510 can vary. A bottom portion 1520A of the fin 1520 is configured to be slidably received within a track perimeter 1522 defined about the track 1516 in order to secure the connection between the location sensor 50 and the interface 1510.

[0052] The interface body 1512 defines an outer surface 1524 that is shaped and configured so as to match the outer surface 50A of the location sensor 50 when the interface 1510 is attached to the location sensor. Of course, the particular shape and configuration of both the location sensor and the interface can vary from what is shown and described. Also, the particular connection point of the interface with the location sensor can vary. The interface body 1512 further defines an end surface 1528 that remains externally accessible when the interface 1510 is operably attached to the location sensor (FIGS. 3A, 3B), as well as an inner surface 1528 (FIGS. 3C, 4B, 4C) that is inaccessible when the interface is attached to the location sensor. As will be described, various connection points are included on both the end surface 1526 and the inner surface 1528 to enable various components of the catheter placement system 10 to operably connect with the location sensor 50. The size, shape, type, and number of connection points can vary from the below discussion.

[0053] FIGS. 4A-4C depict further details regarding the interface 1510. As shown, the end surface 1526 includes various connection points for enabling interconnection with

components of the catheter placement system 10. Specifically, the end surface 1526 includes a pair of ECG lead connector receptacles 1530 disposed in a recess 1532. The ECG lead connector receptacles 1530 each include a female contact 1530A sized and configured to receive therein a male connector end of the leads of the ECG electrodes 158. In the present embodiment, the recess 1532 is shaped so as to receive a dual connector that includes both male connector ends of the ECG electrodes 158 in a single plug, though other configurations are also possible for the ECG lead connection scheme.

[0054] FIG. 4A shows that the fin 1520 includes an ECG stylet wire receptacle 1542, surrounded by a centering cone 1544, for removably receiving therein a pin contact 170 (FIG. 7) of a tether connector 132 of the ECG stylet 130 (FIG. 6). Further details regarding connection of the ECG stylet 130 to the interface 1510 and the location sensor 50 are given further below.

[0055] FIG. 4A further shows that the console cable 140 is permanently attached so as to extend from the interface 1510, as shown. The length of the console cable 140 can vary according to need, but is sufficient in the present embodiment to extend between the location sensor 50 and the console 20, as shown in FIG. 2.

[0056] The inner surface 1528 of the interface 1510 includes various connection points for enabling interconnection of the aforementioned components with the location sensor. As shown, in FIGS. 4B and 4C, a USB type B plug 1550 of the console cable 140 extends from the interface inner surface 1528 to operably connect with a corresponding USB type B receptacle 1570 (FIG. 5) disposed in the pocket 1514 when the interface 1510 mates with the location sensor 50. Similarly, a rounded, cylindrical ECG plug 1560 extends from the interface inner surface 1528 to operably connect with a corresponding, cylindrically shaped ECG receptacle 1580 defined in the pocket 1514 when the interface 1510 mates with the location sensor 50.

[0057] Specifically, the ECG plug 1560 includes an ECG stylet wire contact 1560A that is operably connected with the ECG stylet wire receptacle 1542 on the fin 1520, as well as two ECG lead contacts 1560B that are operably connected with the ECG lead electrical contacts 1530A in the ECG lead receptacle 1530 included on the interface end surface 1526. In the present embodiment, the ECG lead contacts 1560B are integrally formed with the ECG lead contacts 1530A and are formed as sleeves so as to receive corresponding ECG lead pins 1580B disposed in the ECG receptacle 1580. The ECG receptacle 1580 further includes an ECG stylet pin 1580A for operably connecting with the sleeve-type ECG stylet wire contact 1560A of the ECG plug 1560. FIGS. 3A, 8A, and 8B show the manner of attachment of the interface 1510 within the pocket 1514 of the location sensor 50.

[0058] FIGS. 6 and 7 show details of the ECG stylet 130, including the pin contact 170 included in a channel 172 of the tether connector 132, as described further above. As shown in FIGS. 8A and 8B, the tether connector 132 is slid over the fin 1520 in a snug friction fit such that the pin contact 170 is received within the ECG stylet wire receptacle 1542. The ECG stylet wire receptacle 1542 is operably connected within the interface body 1512 with the ECG stylet wire contact 1560A. Thus, this connection establishes an electrically conductive pathway from the ECG stylet 130 to the location sensor 50 via the operable connections of the

pin contact **170** with the ECG stylet wire receptacle **1542**, and the ECG stylet wire contact **1560A** (FIG. 4C) of the interface **1510** with the ECG stylet wire pin **1580A** (FIG. 5) of the location sensor. This, in turn, enables ECG signals detected by the ECG stylet **130** to be conveyed to the location sensor **50** and, in one embodiment, the console **20** for processing by the system **10**.

[0059] Correspondingly, FIG. 8B shows the connector ends of the leads of the ECG external electrodes **158** received within the ECG lead connector receptacles **1530** of the interface **1510** such that they each operably connect with a corresponding one of the electrical contacts **1530A** there-within. Thus, conductive pathways are established from the ECG external electrodes **158** to the location sensor via the operable connections of the connector ends of the ECG external electrode leads with ECG lead connector receptacles **1530**, and the ECG lead contacts **1560B** (FIG. 4C) of the interface **1510** with the ECG lead pins **1580B** (FIG. 5) of the location sensor.

[0060] Also, conductive pathways are established from the location sensor **50** to the console **20** (FIGS. 1, 2) via the operable connection of the console cable **140**, namely, the operable connection of its male connector **1550** of the interface **1510** (FIG. 4C) with the receptacle **1570** of the location sensor (FIG. 5). Note that while shown as a USB-type cable, the console cable can include other styles, types, form factors, etc.

[0061] In the above-described configurations, therefore, the location sensor and attached components are ready for use by the catheter placement system **10**, in one embodiment. Indeed, FIG. 12 shows the manner of use of the location sensor **50** when connected with the various components described above during a catheter insertion procedure using the catheter placement system **10**. Note that the tether connector **132** is configured to pierce a sterile drape **1600** (which is placed over the patient during catheter insertion procedures) such that regions above the drape are considered a sterile environment, while the location sensor **50**, the fin **1520**, and the console cable **140** are not considered sterile. The manner in which the tether connector **132** is able to pierce the drape **1600** and operably connect with the location sensor **50** enables such a connection without compromising the sterility of the sterile field.

[0062] Note that the various connecting components described with the above electrically conductive connections can vary in size, type, number, etc., from what is discussed herein. Note further that in the present embodiment attachment of the interface **1510** with the location sensor **50** is maintained via the friction fit of the various electrical connections between the interface and the location sensor, as just discussed above. In another embodiment, additional features can be included on one or both of the interface body **1512** and the location sensor **50** to provide a friction fit or other type of securement to maintain attachment between the interface and the location sensor.

[0063] FIGS. 9-11 depict the interface **1510** according to another embodiment, wherein the ECG stylet wire contact **1560A** and the two ECG lead contacts **1560B** discretely extend from interface body **1512** instead of being included in a male plug (FIG. 10). Correspondingly, the ECG stylet wire pin **1580A** and the two ECG lead pins **1580B** of the location sensor **50** are discretely positioned instead of grouped within a receptacle in the location sensor pocket **1514** (FIG. 9). Also, note that the shape and configuration of

the track **1516** of the location sensor **50** (FIG. 9) differs from that of the previous embodiment. These and other modifications are therefore contemplated.

[0064] FIG. 13 shows an interface connector configuration according to another embodiment, wherein a connector block **1660** includes not only the ECG stylet wire contact **1560A** and the ECG lead contacts **1560B**, but also two electromagnetic contacts **1660A** for providing power to an electromagnet element disposed in the ECG stylet **130** to be used when the system **10** is in TLS mode, described above. The particular arrangement and configuration of the various connectors can vary from what is shown here.

[0065] It is noted that the interface **1510** in one embodiment is reusable for multiple catheter insertion procedures, but is easily removable and replaceable should the need arise, such as in cases where damage to the wires or cables of the catheter insertion system **10** have been damaged due to use, accident, or repeated cleaning cycles. This, in turn enables replacement without the need to replace the entire location sensor, which can involve considerably more cost. Further, it is appreciated that the ECG stylet **130** and the external ECG electrodes and their leads are disposable and are disposed of after a single catheter insertion is complete. The console cable in one embodiment is permanently attached with the interface **1510** and thus is reusable. Also, though described here as employed with a location sensor, the interface in other embodiments can be employed to operably connect with other types of medical devices where interconnections as are enabled by the interface as described herein are needed. Further, note that various types of electrical connectors can be used to operably connect the various components described herein, including circuit board-edge connectors, peg and cuff-type connectors, type-C and other types of USB connectors, spring-loaded pins for pressing against conductive pads, etc. These and other connectors are therefore contemplated.

[0066] Embodiments of the invention may be embodied in other specific forms without departing from the spirit of the present disclosure. The described embodiments are to be considered in all respects only as illustrative, not restrictive. The scope of the embodiments is, therefore, indicated by the appended claims rather than by the foregoing description. All changes that come within the meaning and range of equivalency of the claims are to be embraced within their scope.

What is claimed is:

1. A connector interface designed to connect components of the catheter placement system to a location sensor of the catheter placement system, the connector interface comprising:

a console connection interface designed for mating with a console port of the location sensor;

an electrocardiogram (ECG) connection interface designed for mating with an ECG port of the location sensor; and

a stylet connection interface designed for mating with a stylet connector recess of the location sensor,

wherein the connector interface enables simultaneous mating of the console connection interface, the ECG connection interface, and the stylet connection interface to the location sensor.

2. The connector interface according to claim 1, wherein the stylet connection interface comprises a fin portion.

3. The connector interface according to claim 2, wherein the fin portion includes a receptacle configured to receive therein a male connector of an ECG stylet of the catheter placement system.

4. The connector interface according to claim 3, wherein the location sensor includes at least one sensor configured to detect a magnetic element included with the ECG stylet of the catheter placement system.

5. The connector interface according to claim 1, wherein the removable connector interface further comprises a recess including one or more ECG lead contacts in communication with the ECG connection interface.

6. The connector interface according to claim 1, further comprising a USB cable that operably connects the location sensor to a console of the catheter placement system.

7. The connector interface according to claim 6, wherein the USB cable is permanently attached to the connector interface.

8. The connector interface according to claim 1, wherein the location sensor is designed to be temporarily disposed on a chest portion of a patient.

9. The connector interface according to claim 1, wherein the connector interface is removable from the location sensor and is designed for multiple uses.

* * * * *

专利名称(译)	基于ECG的导管定位系统的连接器接口		
公开(公告)号	US20190320982A1	公开(公告)日	2019-10-24
申请号	US16/457606	申请日	2019-06-28
申请(专利权)人(译)	C. R. BARD , INC.		
当前申请(专利权)人(译)	C. R. BARD , INC.		
[标]发明人	MISENER ANTHONY K DAVIS ZACHARY S STATS JASON R		
发明人	MISENER, ANTHONY K. DAVIS, ZACHARY S. STATS, JASON R.		
IPC分类号	A61B5/00 A61B5/06 A61M25/01 A61B5/0404 A61B5/042		
CPC分类号	A61B2562/227 A61B5/0404 A61M25/01 A61B5/6852 A61B5/062 A61M2230/04 A61B5/042		
优先权	62/185477 2015-06-26 US		
外部链接	Espacenet	USPTO	

摘要(译)

公开了一种连接器接口，其被配置为使得部件能够与导管放置系统的位置传感器互连。导管放置系统被配置成帮助临床医生将导管定位在患者体内的期望位置。在一个实施例中，位置传感器组件包括用于临时放置在患者身体的一部分上的位置传感器主体，以及连接器接口。连接器接口被配置为可移除地附接到位置传感器，并在位置传感器和导管放置系统的附加部件之间提供多个导电路径，以使附加部件能够与位置传感器可操作地连接。连接器接口还包括第一连接器，该第一连接器配置为通过插入在第一和第二连接器之间的盖布与导管放置系统的附加部件之一的第二连接器可操作地连接。

