



US 20190204398A1

(19) **United States**

(12) **Patent Application Publication**

**LEE et al.**

(10) **Pub. No.: US 2019/0204398 A1**

(43) **Pub. Date:**

**Jul. 4, 2019**

(54) **METHOD AND APPARATUS FOR PROVIDING CONTENT RELATED TO CAPTURE OF MEDICAL IMAGE**

(30) **Foreign Application Priority Data**

Aug. 9, 2013 (KR) ..... 10-2013-0094900

(71) Applicant: **SAMSUNG ELECTRONICS CO., LTD.**, Suwon-si (KR)

**Publication Classification**

(51) **Int. Cl.**  
*G01R 33/28* (2006.01)  
*G16H 40/63* (2006.01)  
*A61B 5/055* (2006.01)  
*A61B 6/00* (2006.01)  
*A61B 5/00* (2006.01)

(72) Inventors: **Dae-ho LEE**, Seongnam-si (KR);  
**Sang-young ZHO**, Seoul (KR);  
**Joon-soo KIM**, Seoul (KR)

(73) Assignee: **SAMSUNG ELECTRONICS CO., LTD.**, Suwon-si (KR)

(52) **U.S. Cl.**  
CPC ..... *G01R 33/283* (2013.01); *G16H 40/63* (2018.01); *G01R 33/4828* (2013.01); *A61B 6/46* (2013.01); *A61B 5/4884* (2013.01); *A61B 5/055* (2013.01)

(21) Appl. No.: **16/298,366**

(22) Filed: **Mar. 11, 2019**

**Related U.S. Application Data**

(63) Continuation of application No. 15/613,550, filed on Jun. 5, 2017, now Pat. No. 10,274,552, which is a continuation of application No. 14/454,992, filed on Aug. 8, 2014, now Pat. No. 9,753,103.

(57) **ABSTRACT**

A method of providing content related to capture of a medical image of an object is provided. The method includes acquiring at least one of information related to a state of the object and information related to a capture protocol, determining content to be provided to the object on a basis of the acquired information, and outputting the determined content.

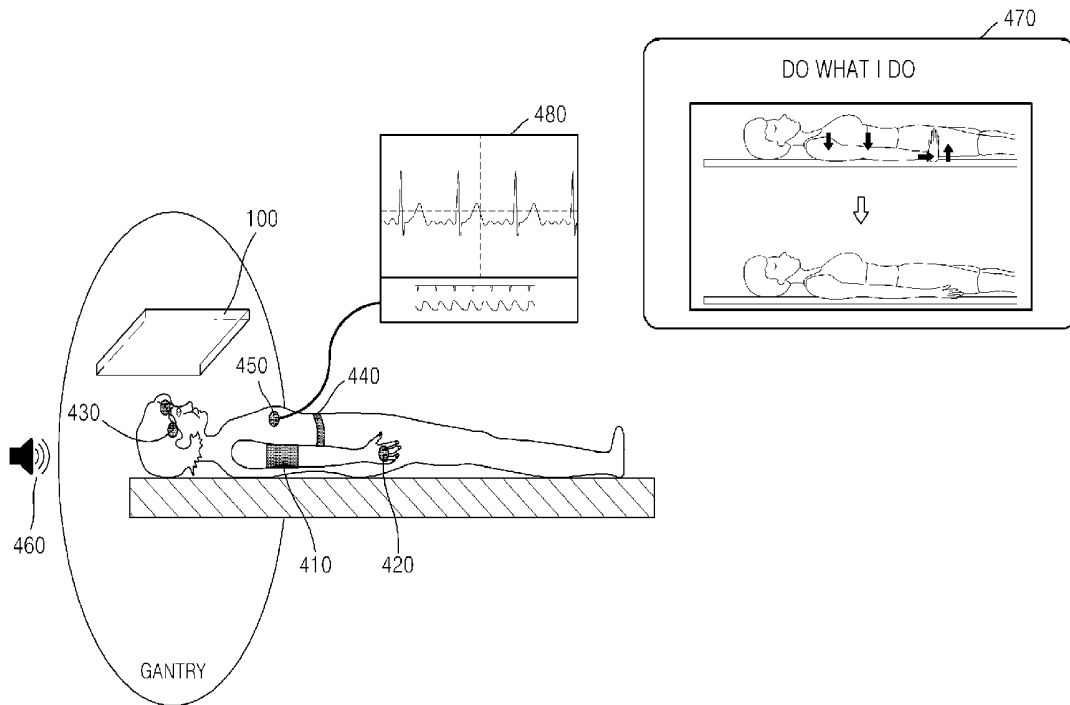

FIG. 1

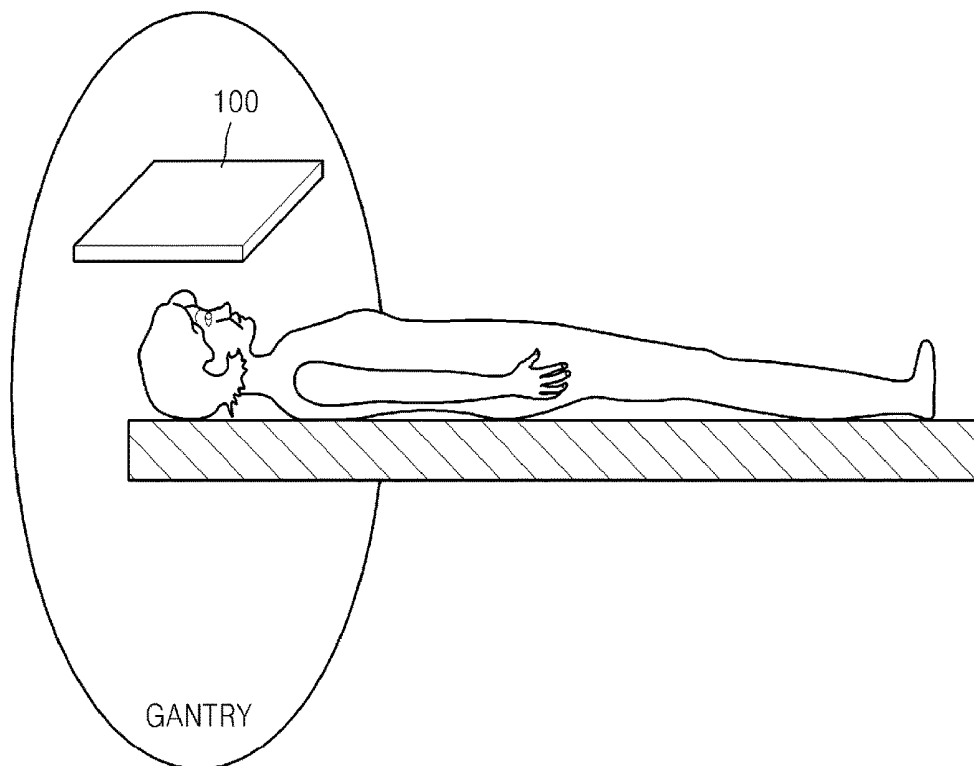

FIG. 2

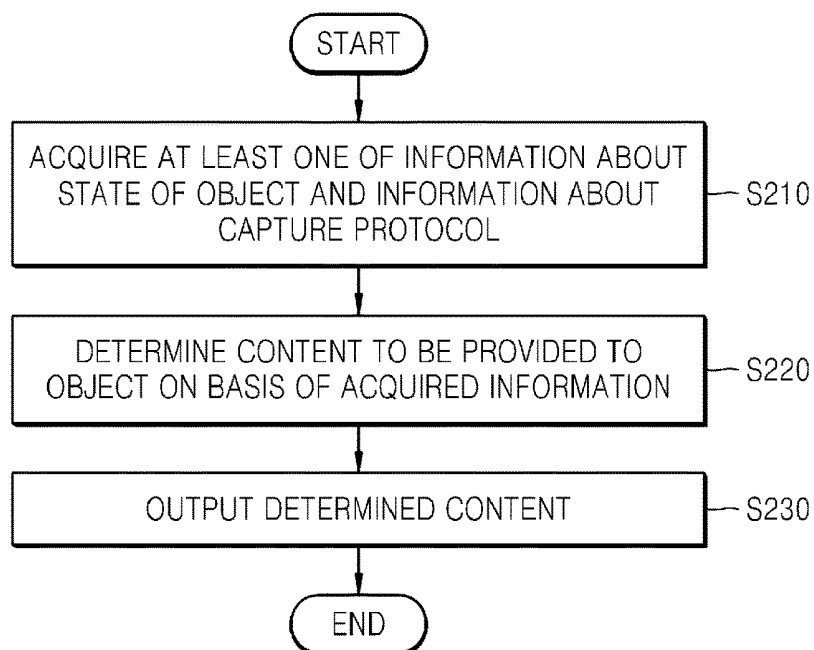

FIG. 3

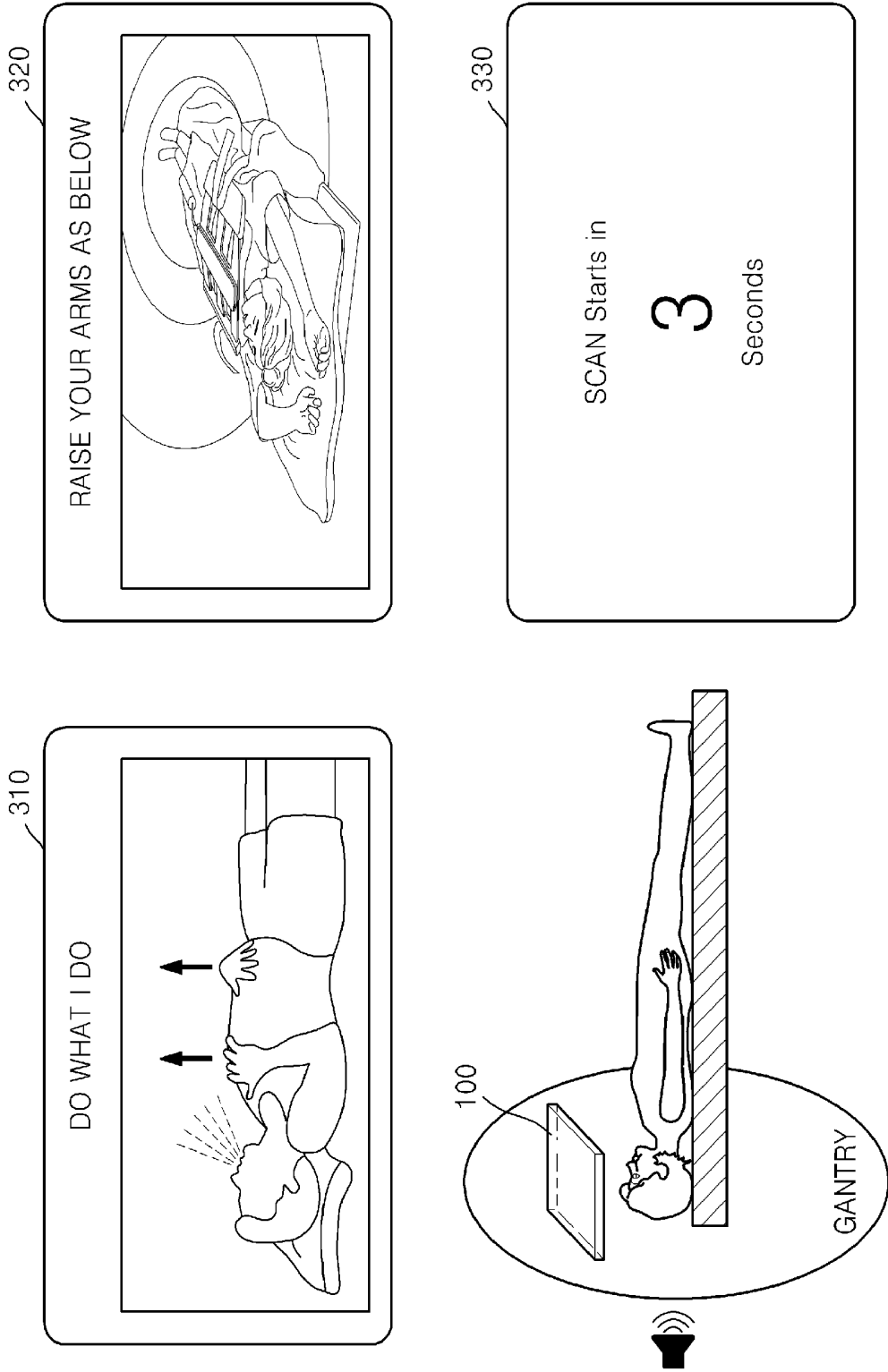

FIG. 4

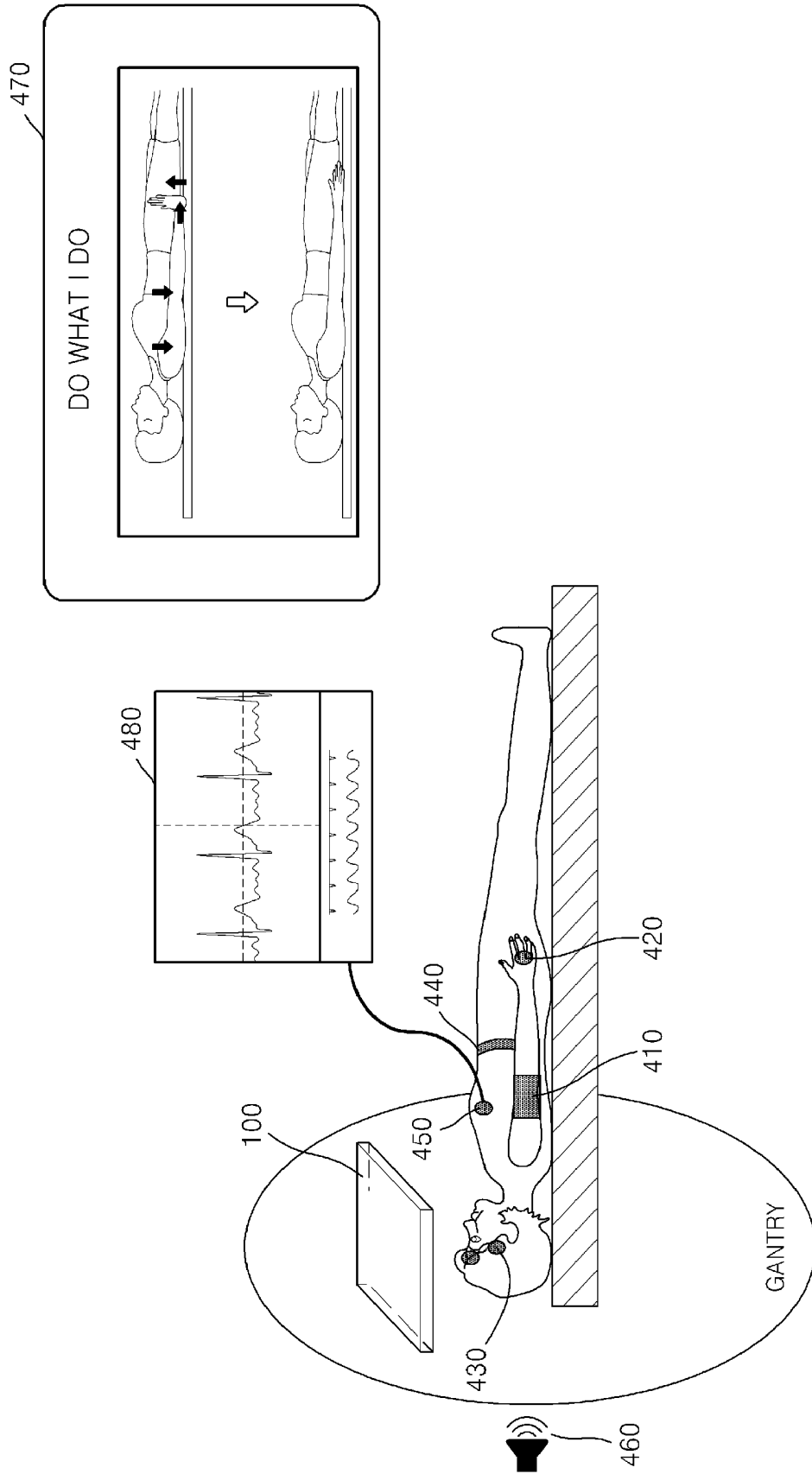

FIG. 5

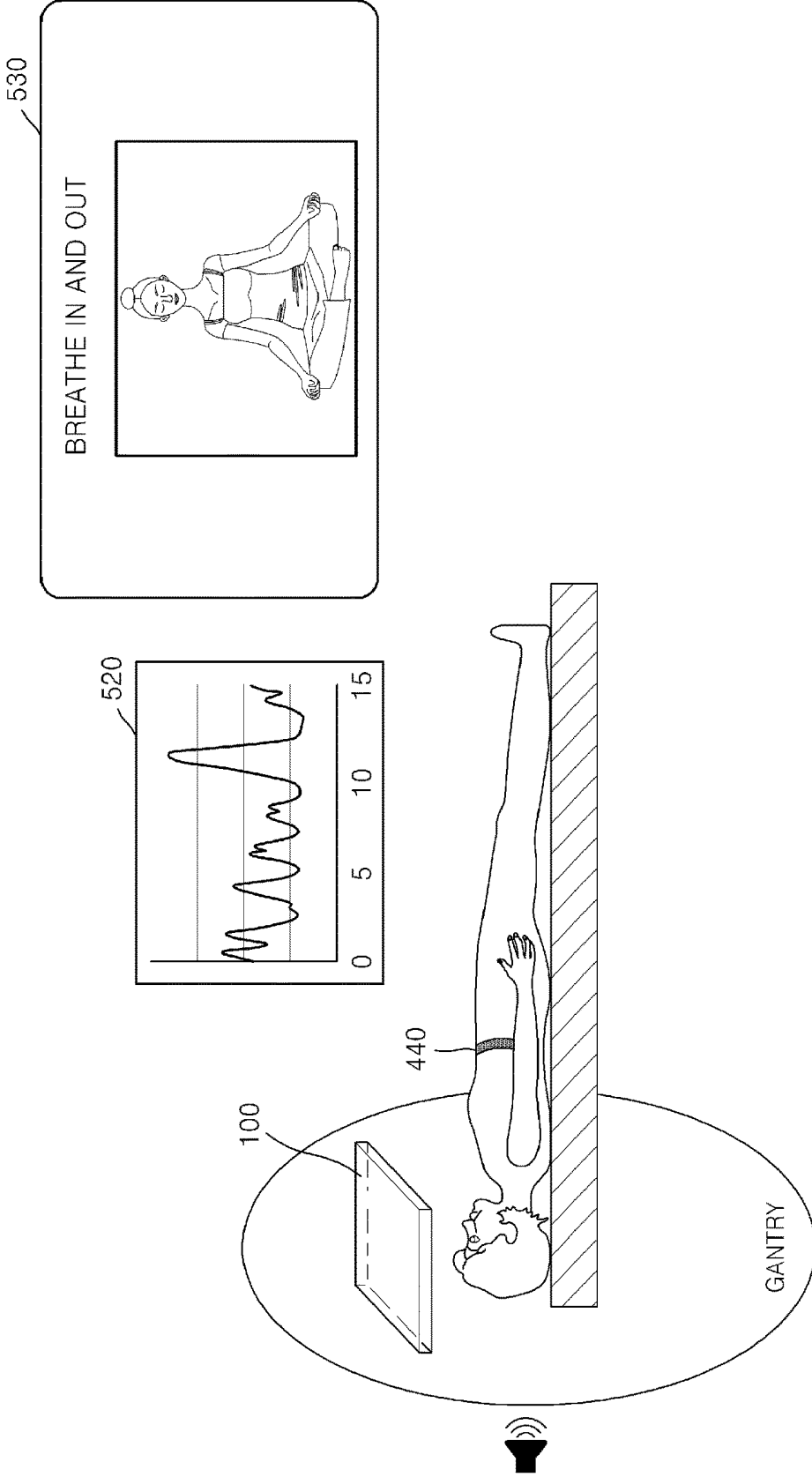

FIG. 6

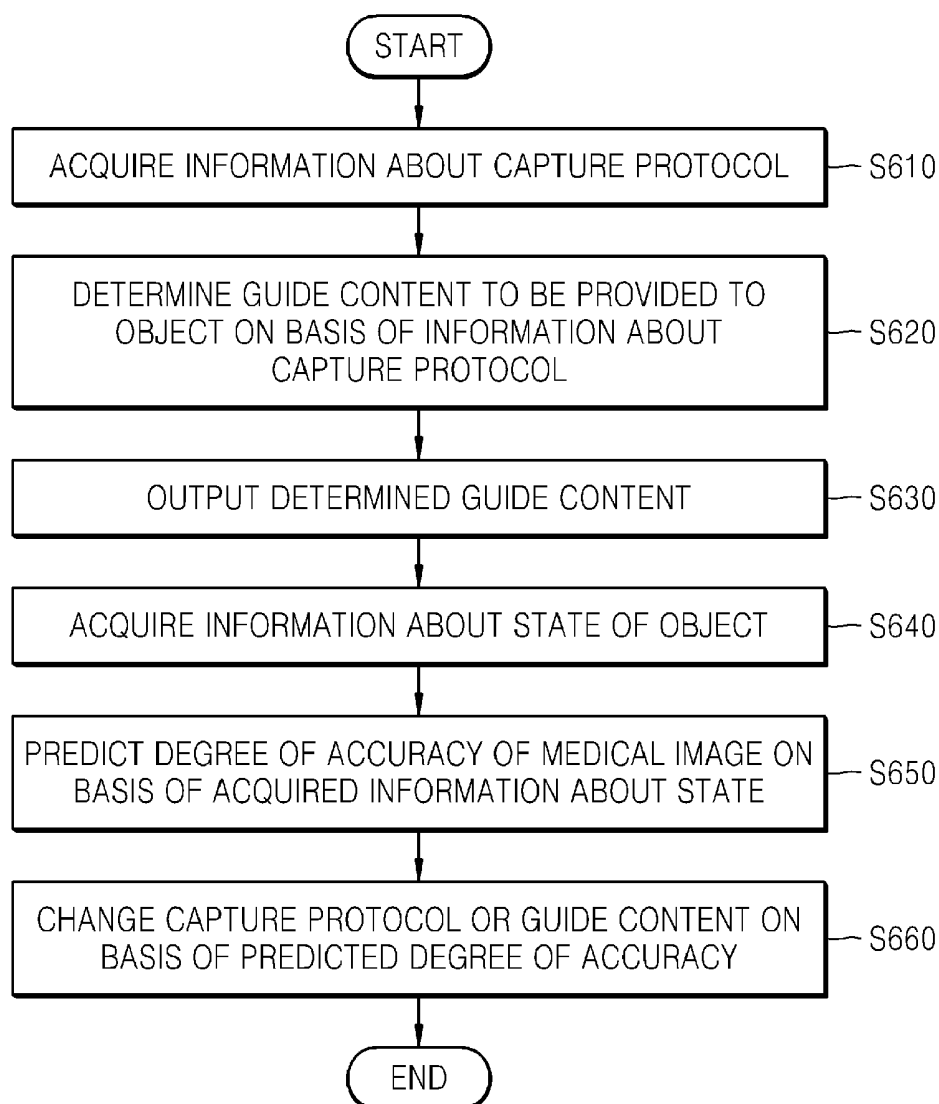

FIG. 7

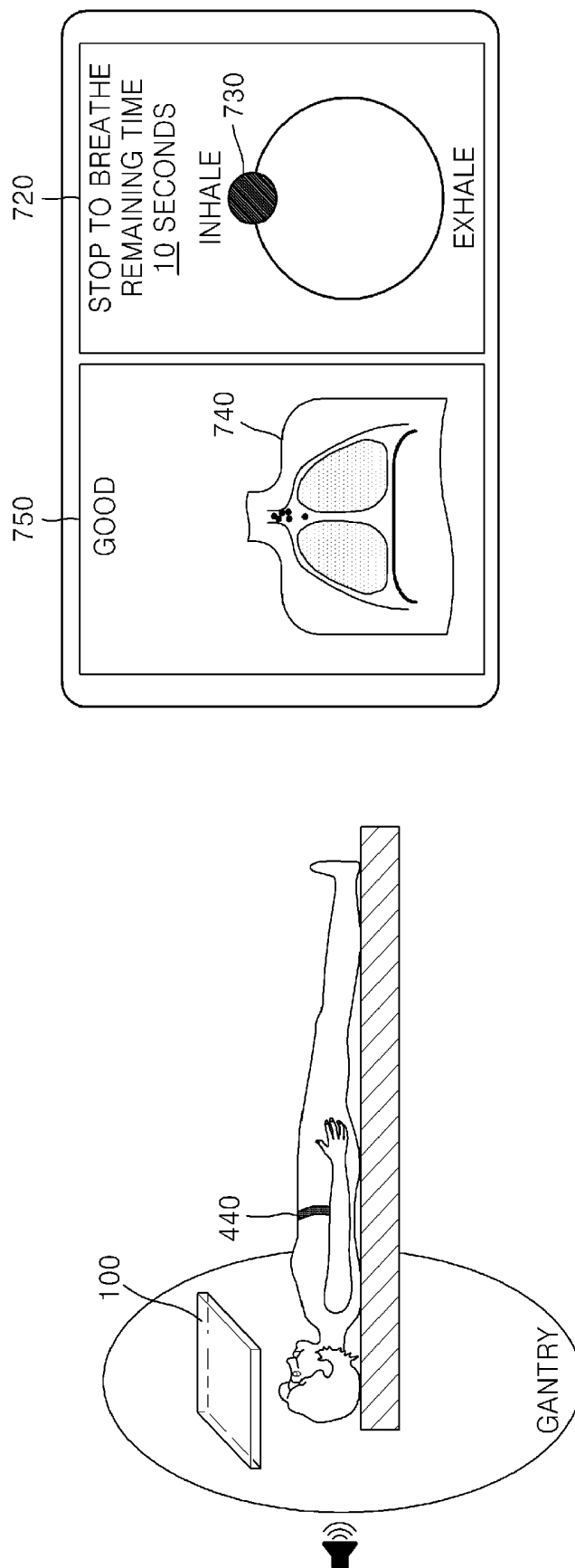

FIG. 8

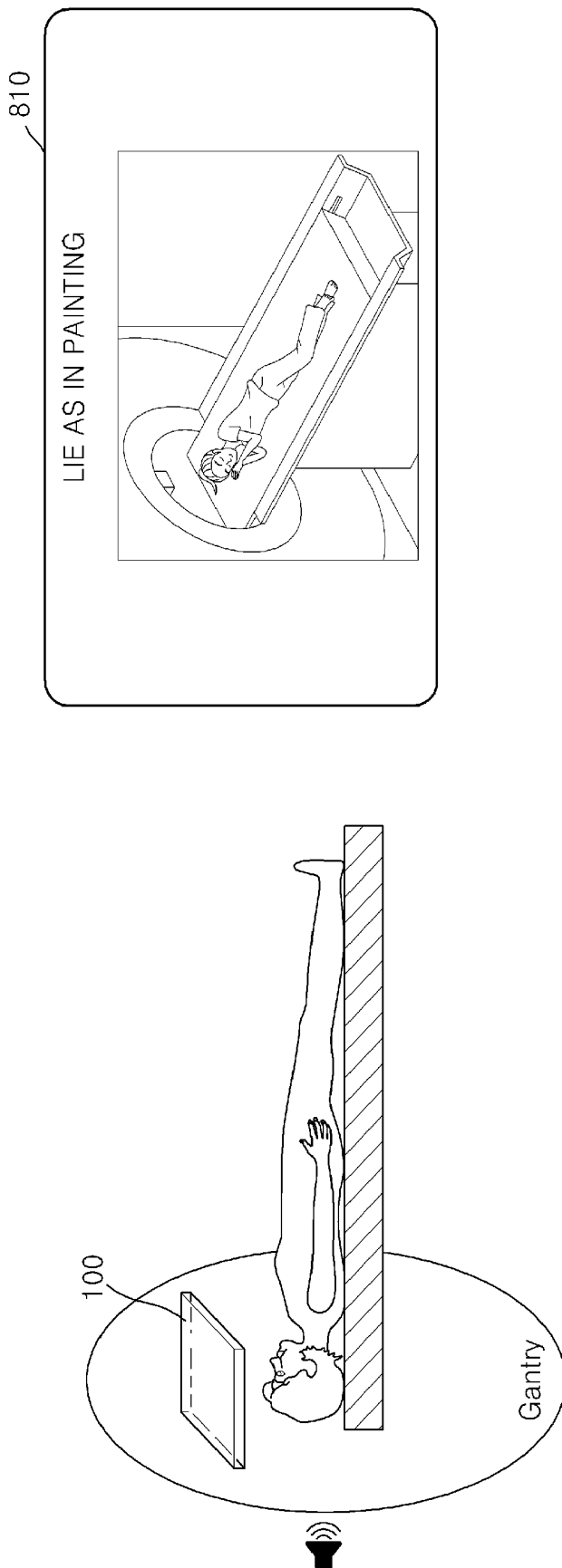

FIG. 9

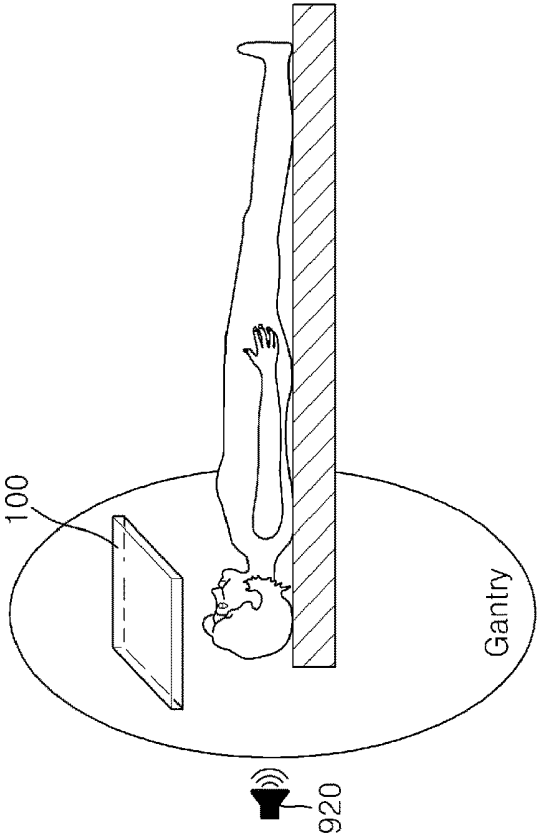
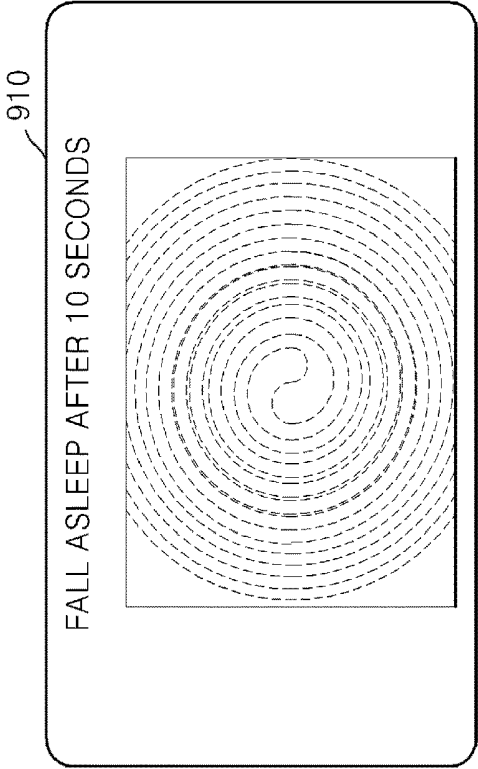

FIG. 10

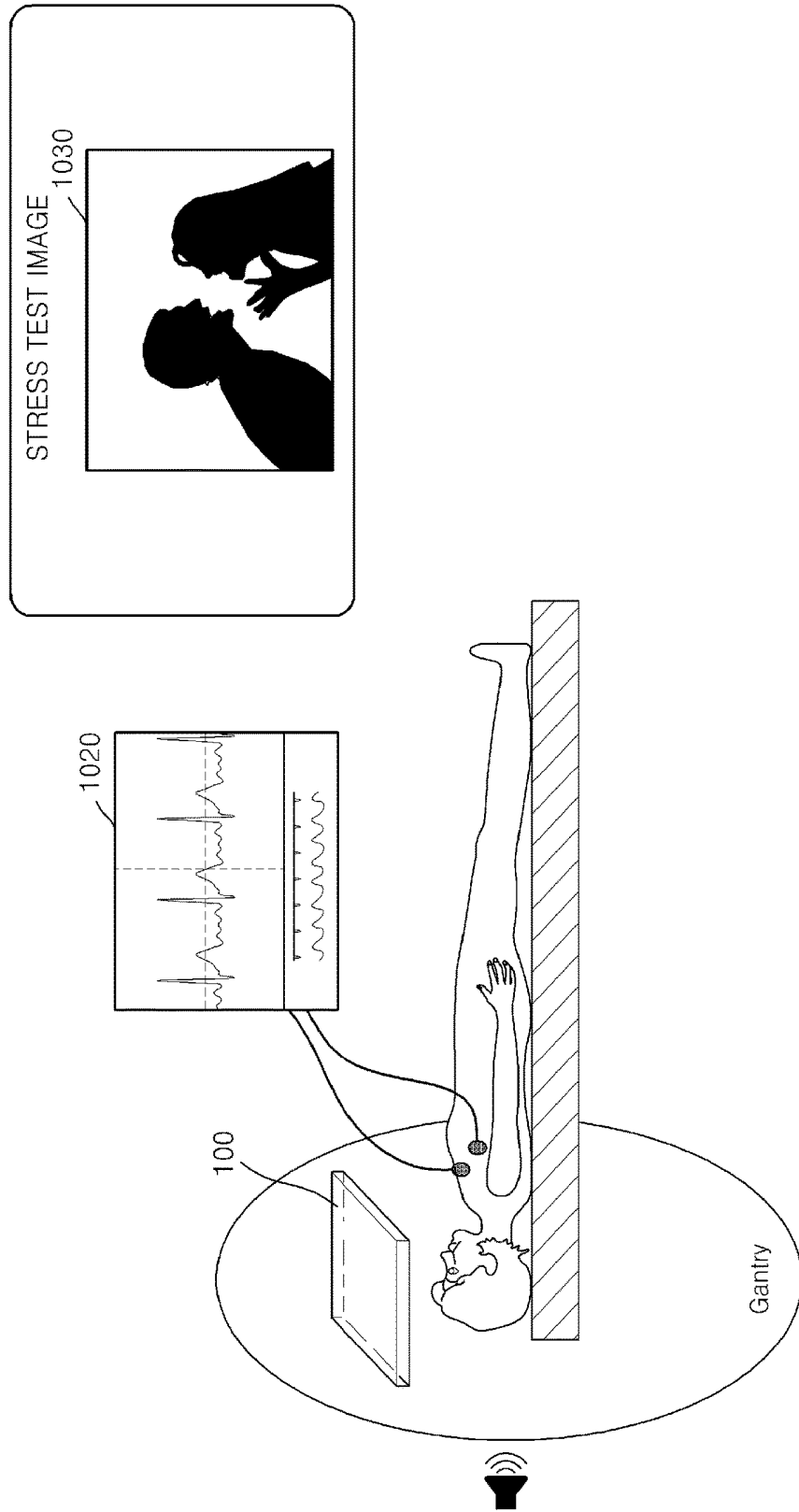

FIG. 11

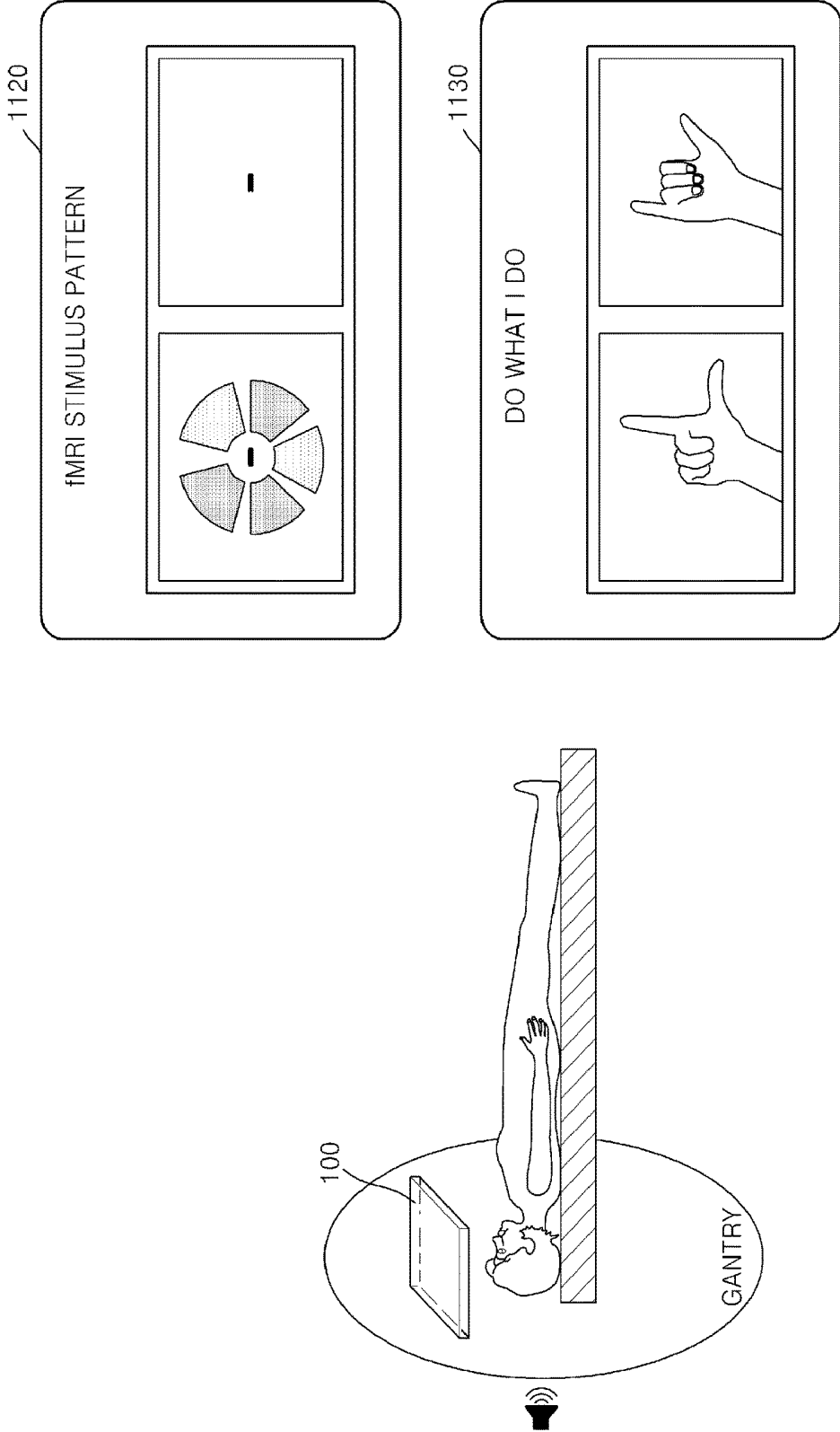

FIG. 12

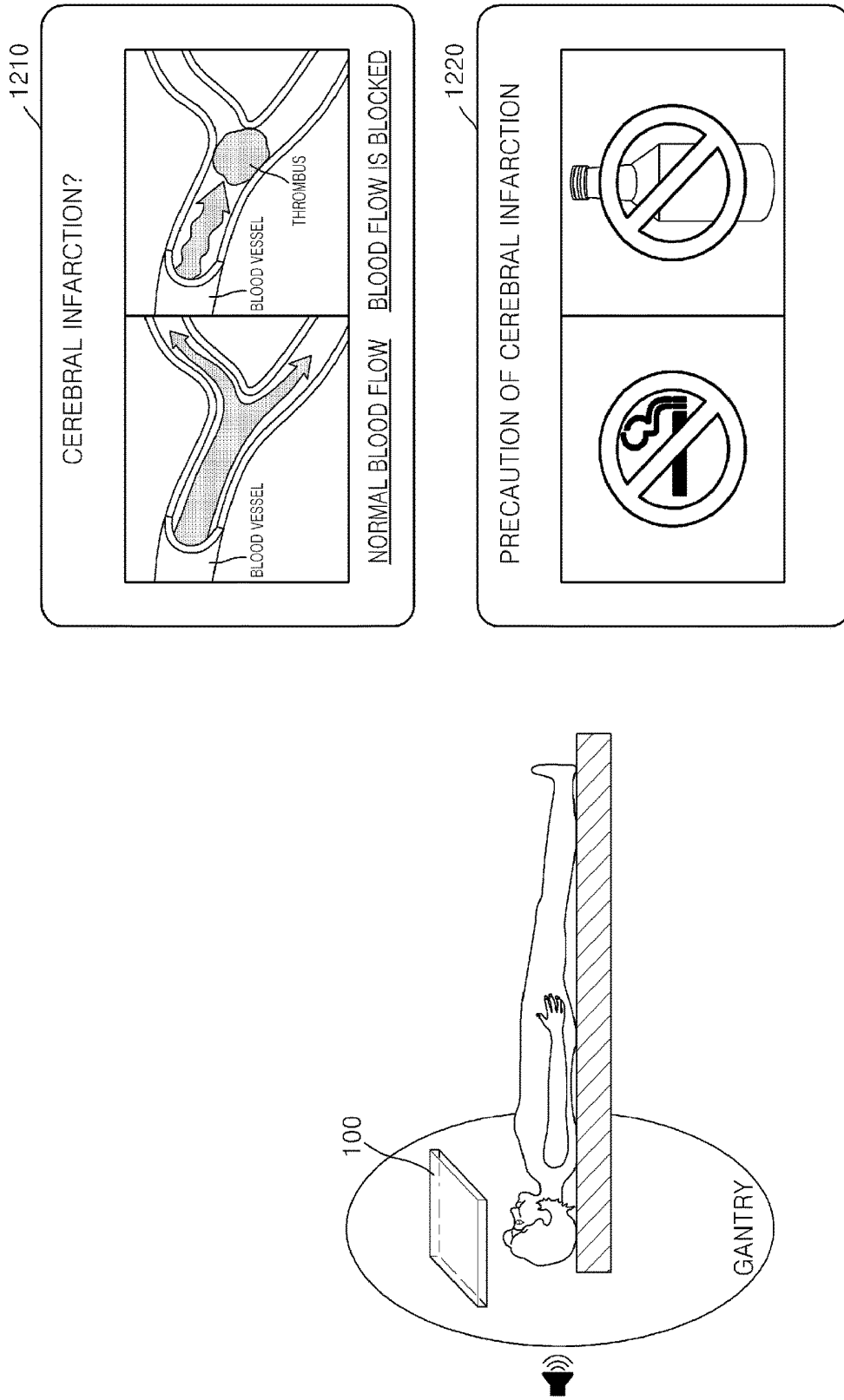

FIG. 13

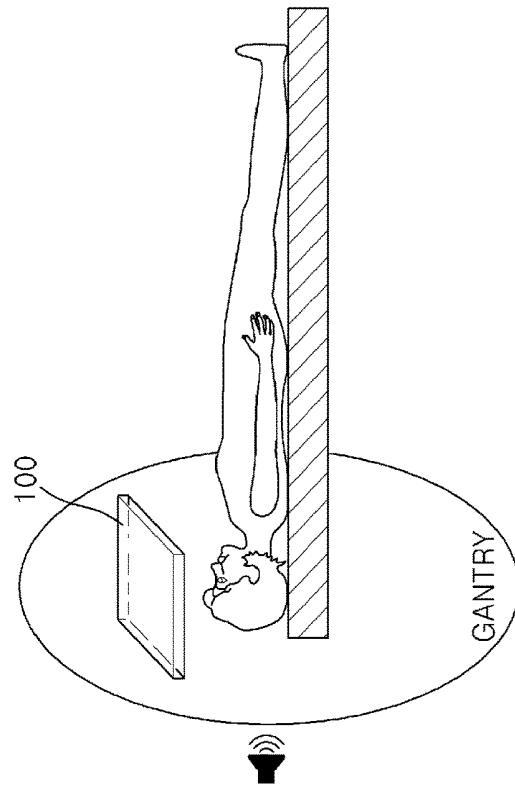
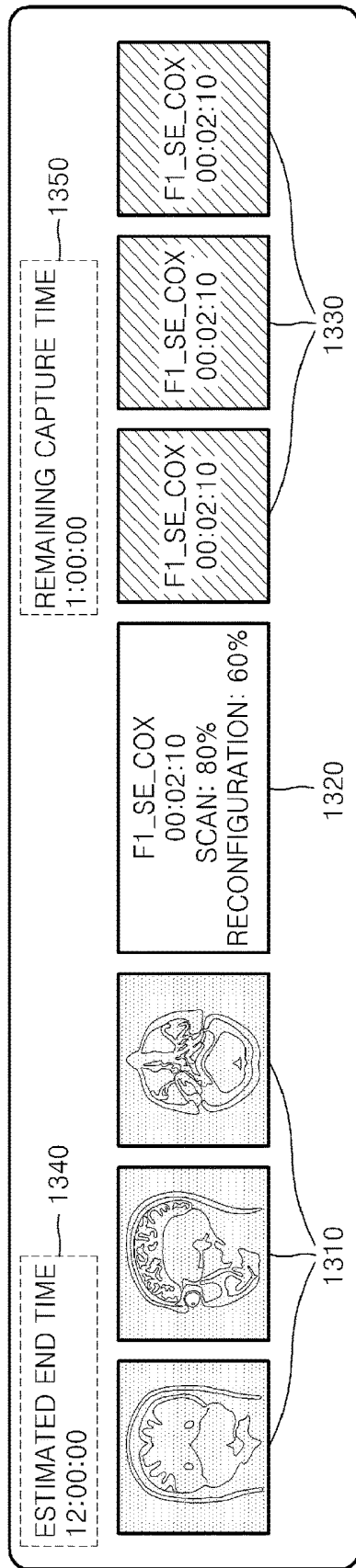

FIG. 14

100

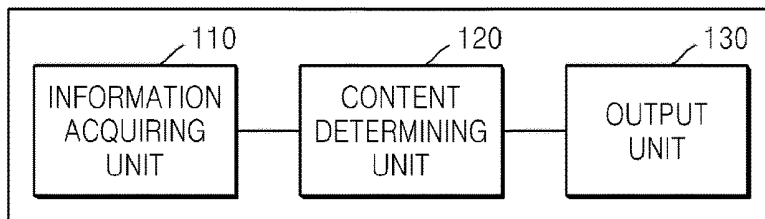
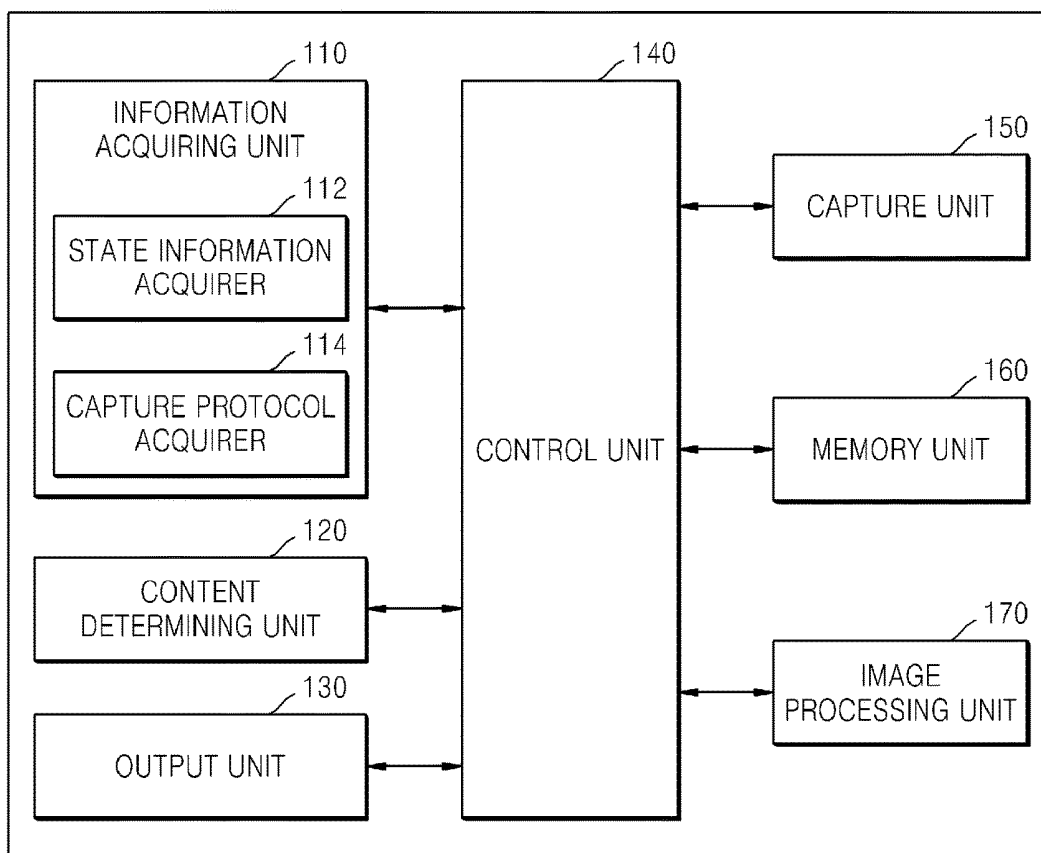

FIG. 15

100



**METHOD AND APPARATUS FOR  
PROVIDING CONTENT RELATED TO  
CAPTURE OF MEDICAL IMAGE**

RELATED APPLICATIONS

[0001] This is a continuation application of U.S. patent application Ser. No. 15/613,550, filed Jun. 5, 2017, in the U.S. Patent and Trademark Office, which application is a continuation application of U.S. patent application Ser. No. 14/454,992, filed Aug. 8, 2014, in the U.S. Patent and Trademark Office, which issued as U.S. Pat. No. 9,753,103 and claims priority from Korean Patent Application No. 10-2013-0094900, filed on Aug. 9, 2013, in the Korean Intellectual Property Office, the disclosures of which are incorporated herein by reference in their entireties.

BACKGROUND

1. Technical Field

[0002] One or more exemplary embodiments relate to a method and apparatus for providing to an object content related to the capture of a medical image.

2. Description of the Related Art

[0003] In capturing an object with a medical apparatus such as a magnetic resonance imaging (MRI) apparatus or a computed tomography (CT) apparatus, the object alone lies in a narrow space such as a gantry of the medical apparatus. A user of a medical apparatus communicates with an object by using a microphone and a speaker. However, it is not easy to fully determine a detailed state such as a change in a physical state and a mental state of the object. Therefore, in capturing a medical image, a user of a medical apparatus captures the medical image with no consideration of a detailed state of an object, thus sometimes resulting in a medical accident. In response to capturing an object with a detailed state of the object being accurately determined, an inaccurate medical image is acquired. This results in sometimes having to once again capture the object.

[0004] Moreover, a user of a medical apparatus may notify an object of a breathing method or the optimal posture which is required according to the order of capture, through a voice, but when an object is a child or a foreigner, communication may not be smooth. In addition, it is difficult for an object, unskilled in the capture of a medical image, to learn a correct breathing method and the optimal posture in a short time through instruction by a user of a medical apparatus.

SUMMARY

[0005] One or more in its entirety embodiments include a method and apparatus for automatically providing content related to the capture of a medical image by using state information or capture information related to an object.

[0006] Additional aspects will be set forth in part in the description which follows and, in part, will be apparent from the description, or may be learned by practice of the exemplary embodiments.

[0007] According to one or more exemplary embodiments, a method of providing content related to capture of a medical image of an object includes: acquiring at least one of information related to a state of the object and information related to a capture protocol; determining content to be

provided to the object on a basis of the acquired information; and outputting the determined content.

[0008] The information related to the state of the object includes at least one of information related to a body signal of the object, information related to a posture of the object, information related to a voice of the object, and information related to a motion of the object.

[0009] The information related to the body signal includes information related to at least one of a body temperature, a blood pressure, a heart rate, a breath pattern, a brainwave and muscular motion of the object.

[0010] The information related to the capture protocol includes information related to at least one of a captured part of the object, a capture direction, a pulse sequence to be used for capture, a capture purpose, precautions for capture, a capture time, and setting information before starting capture.

[0011] The determining includes selecting content used to stabilize the breath of the object or content used to guide the breath of the object as content to be provided to the object in response to a breath of the object being irregular.

[0012] The determining includes selecting content used to stabilize the heartbeat of the object as content to be provided to the object in response to the heart rate of the object among the information related to the heartbeat of the object being equal to or higher than a predetermined reference value.

[0013] The information related to the motion of the object includes information related to at least one of a gesture, which is expressed with at least one of the hands, the feet, the head, the eyes, and fingers of the object, and a change of expression of the object.

[0014] The determining includes selecting at least one of content used to display a time remaining until starting capture, content used to guide a breathing method of the object before starting the capture, and content used to guide a posture of the object before starting the capture, on a basis of the setting information before starting capture.

[0015] The determining includes selecting content used to guide the breath of the object and required according to the capture protocol.

[0016] The determining includes selecting content used to guide the posture of the object and required according to the capture protocol.

[0017] The information related to the capture protocol includes information related to a capture protocol used to acquire a functional magnetic resonance (fMR) image of the object, and the determining includes selecting content used to activate the brain of the object, on a basis of the information related to the capture protocol used to acquire the fMR image.

[0018] The information related to the capture protocol includes information related to a protocol used to capture an MR image of the object when performing a stress test for the heart of the object, and the determining includes selecting content used to induce the heart rate of the object to increase, on a basis of the information related to the capture protocol.

[0019] The information related to the capture protocol includes information related to a capture protocol for an MR image of a sleeping state of the object, and the determining includes selecting content used to induce the object to sleep, on a basis of the information related to the capture protocol.

[0020] The outputting includes outputting the determined content by using at least one of an image, a video, sound and text.

**[0021]** According to one or more exemplary embodiments, an apparatus for providing content related to capture of a medical image of an object includes: an information acquirer configured to acquire at least one of information related to a state of the object and information related to a capture protocol; a content determiner configured to determine content to be provided to the object, on a basis of the acquired information; and an output configured to output the determined content.

**[0022]** The information acquirer includes a state information acquirer that acquires information related to the state of the object; and a capture protocol acquirer that acquires the information related to the capture protocol.

**[0023]** In response to a breath of the object being irregular, the content determiner is configured to select content used to stabilize the breath of the object or content used to guide the breath of the object, as content to be provided to the object.

**[0024]** In response to the heart rate of the object among the information related to the heartbeat of the object being equal to or higher than a predetermined reference value, the content determiner is configured to select content, used to stabilize the heartbeat of the object, as content to be provided to the object.

**[0025]** The content determiner is configured to select at least one of content used to display a time remaining until starting capture, content used to guide a breathing method of the object before starting the capture, and content used to guide a posture of the object before starting the capture on a basis of the setting information, before starting capture.

**[0026]** The content determiner is configured to select content used to guide the breath of the object and required according to the capture protocol.

**[0027]** The content determiner is configured to select content used to guide the posture of the object and required according to the capture protocol.

**[0028]** The information related to the capture protocol includes information related to a capture protocol used to acquire a functional magnetic resonance (fMR) image of the object, and the content determiner is configured to select content used to activate the brain of the object, on a basis of the information related to the capture protocol used to acquire the fMR image.

**[0029]** The information related to the capture protocol includes information related to a protocol used to capture an MR image of the object in response to performing a stress test for the heart of the object, and the content determiner is configured to select content used to induce the heart rate of the object to increase, on a basis of the information related to the capture protocol.

**[0030]** The information related to the capture protocol includes information related to a capture protocol for an MR image of a sleeping state of the object, and the content determiner is configured to select content used to induce the object to sleep, on a basis of the information related to the capture protocol.

**[0031]** The output is configured to output the determined content by using at least one of an image, a video, sound and text.

**[0032]** An information acquirer configured to acquire information related to a state of the user and information related to a capture protocol; a content determiner configured to determine content to be provided to the user, on a basis of the acquired information; and an output configured to output the determined content to the user.

**[0033]** An aspect of an exemplary embodiment may provide an apparatus for providing content related to capture of a medical image of a user, the apparatus including: an information acquirer configured to acquire information related to a state of the user and information related to a capture protocol; a content determiner configured to determine content to be provided to the user, on a basis of the acquired information; and an output configured to output the determined content to the user.

**[0034]** According to one or more exemplary embodiments, a non-transitory computer-readable storage medium may store a program for executing the method.

#### BRIEF DESCRIPTION OF THE DRAWINGS

**[0035]** These and/or other aspects will become apparent and more readily appreciated from the following description of the exemplary embodiments, taken in conjunction with the accompanying drawings in which:

**[0036]** FIG. 1 illustrates a content providing apparatus for providing content to an object, according to an exemplary embodiment;

**[0037]** FIG. 2 is a flowchart of a method of providing content related to the capture of a medical image of an object, according to an exemplary embodiment;

**[0038]** FIG. 3 illustrates a method of providing content to an object which is necessary for capture prior to starting the capture, according to an exemplary embodiment;

**[0039]** FIG. 4 illustrates a method of providing content on the basis of body information related to an object, according to an exemplary embodiment;

**[0040]** FIG. 5 illustrates a method of providing content used to stabilize a breath of an object, according to an exemplary embodiment;

**[0041]** FIG. 6 is a flowchart of a method of changing a capture protocol or content to provide on the basis of information related to a state of an object, according to an exemplary embodiment;

**[0042]** FIG. 7 illustrates a method of providing content used to guide a breath of an object according to a capture protocol, according to an exemplary embodiment;

**[0043]** FIG. 8 illustrates a method of providing content used to guide a posture of an object according to a capture protocol, according to an exemplary embodiment;

**[0044]** FIG. 9 illustrates a method of providing content used to induce sleep of an object, according to an exemplary embodiment;

**[0045]** FIG. 10 illustrates a method of providing content used to test stress, according to an exemplary embodiment;

**[0046]** FIG. 11 illustrates a method of providing content for functional magnetic resonance imaging (fMRI) capture, according to an exemplary embodiment;

**[0047]** FIG. 12 illustrates a method of providing content related to an object while capturing a medical image, according to an exemplary embodiment;

**[0048]** FIG. 13 illustrates a method of providing information to an object which is related to the capture of a medical image, according to an exemplary embodiment;

**[0049]** FIG. 14 illustrates a content providing apparatus for providing to an object information related to the capture of a medical image, according to an exemplary embodiment; and

[0050] FIG. 15 illustrates a content providing apparatus for providing to an object information related to the capture of a medical image, according to another exemplary embodiment.

#### DETAILED DESCRIPTION

[0051] Reference will now be made in detail to the exemplary embodiments, examples of which are illustrated in the accompanying drawings, wherein like reference numerals refer to like elements throughout. In this regard, the exemplary embodiments may have different forms and should not be construed as being limited to the descriptions set forth herein. Accordingly, the exemplary embodiments are merely described below, by referring to the figures, to explain aspects of the present description. Expressions such as “at least one of,” when preceding a list of elements, modify the entire list of elements and do not modify the individual elements of the list.

[0052] Terms used herein will be briefly described, and the exemplary embodiments will be described in detail.

[0053] Terms used in the exemplary embodiments have been selected as general terms which are widely used at present, in consideration of the functions of the exemplary embodiments, but may be altered according to the intent of an operator skilled in the art, conventional practice, or introduction of new technology. Also, in response to their being a term which is arbitrarily selected by the applicant in a specific case, in which case a meaning of the term will be described in detail in a corresponding description portion of the exemplary embodiments. Therefore, the terms should be defined on the basis of the entire content of this specification instead of a simple name of each of the terms.

[0054] In this disclosure below, in a description that comprises (or includes or In this disclosure below, when it is described that one comprises (or includes or has) some elements, it should be understood that it may comprise (or include or has) only those elements, or it may comprise (or include or have) other elements as well as those elements if there is no specific limitation. Moreover, each of terms such as “. . . unit”, “. . . apparatus” and “module” described in specification denotes an element for performing at least one function or operation, and may be implemented in hardware, software or the combination of hardware and software.

[0055] The term “image” used herein may denote multi-dimensional data composed of discrete image factors (for example, pixels in a two-dimensional (2D) image and pixels in a three-dimensional (3D) image). For example, an image may include a medical image of an object which is acquired by an X-ray apparatus, a CT apparatus, a magnetic resonance imaging (MRI) apparatus, an ultrasonic apparatus, or another medical image photographing apparatus.

[0056] Moreover, the term “object” used herein may include a person, an animal, a part of the person, or a part of the animal. For example, an object may include an organ such as a liver, a heart, a womb, a brain, breasts, an abdomen, or the like, or a blood vessel. Also, the term “object” may include a phantom. The phantom denotes a material having a volume that is very close to a density of organisms and an effective atomic number, and may include a spherical phantom having a temper similar to a human body.

[0057] Moreover, the term “user” used herein is a medical expert, and may be a doctor, a nurse, a medical technologist,

a medical image expert, or the like, or may be an engineer repairing a medical apparatus. However, definition of the user is not limited thereto.

[0058] Hereinafter, exemplary embodiments will be described in detail to be easily embodied by those skilled in the art with reference to the accompanying drawings. The present invention may, however, be embodied in many different forms and should not be construed as being limited to the exemplary embodiments set forth herein. In the accompanying drawings, a portion irrelevant to a description of the exemplary embodiments will be omitted for clarity. Moreover, like reference numerals refer to like elements throughout.

[0059] According to an exemplary embodiment, a content providing apparatus 100 automatically provides content related to the capture of a medical image to an object on the basis of information related to a state of the object and information related to a capture protocol, thus providing a more convenient and personalized medical image capture environment to a user of the medical apparatus and the object.

[0060] FIG. 1 illustrates the content providing apparatus 100 for providing content to an object, according to an exemplary embodiment.

[0061] The content providing apparatus 100 according to an exemplary embodiment may determine content necessary for capture on the basis of information related to a state of an object and information related to a capture protocol, and provides the determined content to the object.

[0062] Moreover, the content providing apparatus 100 may be connected to a body signal measurer, and on the basis of a body signal of an object that is acquired with the body signal measurer, the content providing apparatus 100 may provide content necessary to capture the object, according to a state of the object. Also, the content providing apparatus 100 may be connected to a voice recognition apparatus, an image recognition apparatus, or a medical image capturing apparatus, and may provide content necessary to capture an object according to a state of the object on the basis of voice information, image information, or medical image of the object.

[0063] Moreover, the content providing apparatus 100 may acquire information related to a capture protocol to provide desired content to an object, according to the capture protocol.

[0064] FIG. 2 is a flowchart of a method of providing content related to the capture of a medical image of an object, according to an exemplary embodiment.

[0065] The method of providing content related to the capture of a medical image of an object, according to an exemplary embodiment, may include operation S210 that acquires at least one of information related to a state of an object and information related to a capture protocol, operation S220 that determines content to be provided to the object on the basis of the acquired information, and operation S230 that outputs the determined content.

[0066] According to an exemplary embodiment, the content providing method may acquire at least one of the information related to the state of the object and the information related to the capture protocol in operation S210.

[0067] The information related to the state of the object, according to an exemplary embodiment, may include at least one of information related to a body signal of the object,

information related to a posture of the object, information related to a voice of the object, and information related to a motion of the object.

[0068] The information related to the body signal, according to an exemplary embodiment may include information related to at least one of a body temperature, blood pressure, a heart rate, a breath pattern, a brainwave and muscular motion of the object.

[0069] For example, the body temperature of the object may be acquired from a thermometer or a thermal infrared sensor. The blood pressure of the object may be acquired from a blood pressure measurer. Information related to a heartbeat of the object may be acquired from an electrocardiogram (ECG) measurer. The breath pattern of the object may be measured by a breath measurer (respiratory bellows). The brainwave of the object may be measured by a brainwave measurer. In addition, the muscular motion of the object may be measured by an electromyogram (EMG) measurer.

[0070] Information related to a motion of an object may include information related to at least one of a gesture, which is expressed with at least one of the hands, the feet, the head, the eyes, and the fingers of the object, and an change of expression of the object.

[0071] The content providing apparatus 100 according to an exemplary embodiment may recognize a posture or motion of an object by using an image sensor. The content providing apparatus 100 may analyze the recognized posture or motion of the hands, the feet, the head, the eyes, the fingers, or the like, of the object in order to determine a gesture having a specific meaning. The gesture having the specific meaning may be previously built in a database type. The content providing apparatus 100 may recognize a facial expression of the object, and determine a current mental state of the object by using a previously built database.

[0072] The information related to the capture protocol, according to an exemplary embodiment, may include information related to at least one of a captured part of an object, a capture direction, a pulse sequence to be used for capture, a capture purpose, precautions for capture, a capture time, and setting information before starting capture.

[0073] The content providing apparatus 100, according to an exemplary embodiment may extract information related to the capture protocol from a database that stores medical image-related information. The database storing the medical image-related information may be built in a picture archiving and communication system (PACS) server, an electronic medical record (EMR) server, a personal health record (PHR) server, and a radiology information system (RIS) server. In other words, the content providing apparatus 100 may extract the information related to the capture protocol from the database built in the PACS server.

[0074] The capture direction of the object included in the capture protocol may include a coronal plane, a sagittal plane or a horizontal plane. Also, the pulse sequence to be used to capture the capture protocol may include, for example, continuation of a radio frequency (RF) pulse which may be repeatedly applied for capturing an MR image, and denote the order of capture based on the elapse of a capture time. Also, the capture time may include a time taken from a start time to an end time of the capture of a medical image, and may include a time remaining until the capture is completed.

[0075] The setting information before starting capture may include information (information related to a time remaining until starting to capture a medical image) related to a capture preparation time expended for an actual capture preparation and information related to a posture which an object needs to make before the medical image is captured. The setting information before starting capture may include information related to a breathing rate or a heart rate equal to or lower than a predetermined reference which is generally required for the object before starting the capture.

[0076] According to an exemplary embodiment, the content providing method may determine content to be provided to the object on the basis of the acquired information in operation S220.

[0077] For example, content for adjusting a breath pattern of an object may be determined based on information related to a breathing rate of the object. In response to the object breathing rapidly above a predetermined reference value, content for gradually stabilizing the breath pattern may be determined as content to be provided to the object. Content for adjusting a heart rate of the object may be determined based on information related to the heart rate of the object. A description on this will be made below with reference to FIGS. 3 to 5.

[0078] According to an exemplary embodiment, the determined content may be output in operation S230. The output content according to an exemplary embodiment may include at least one of an image, sound and text. For example, content to be provided to an object may be displayed on a screen in the form of certain images. Also, the content to be provided to the object may be output as sound, such as a voice, or the like, through a speaker, or the like.

[0079] FIG. 3 illustrates a method of providing content necessary for capture to an object before starting the capture, according to an exemplary embodiment.

[0080] As illustrated in FIG. 3, the content providing apparatus 100 may select at least one of content 310 used to guide a breathing method of an object before starting capture, content 320 used to guide a posture of the object before starting the capture, and content 330 used to display a time remaining until starting the capture, on the basis of the setting information before starting capture.

[0081] The setting information before starting capture may include information related to the object, such as a physical disease, a mental disease, a captured part, a previous medical record, the number of capture experiences of a medical image, an age, and a sex of an object. The setting information before starting capture may include information related to capture, such as a capture protocol to be executed and a capture start time.

[0082] For example, in response to an object having a mental disease such as claustrophobia or panic disorder or has no capture experience of a medical image, as illustrated in FIG. 3, the content providing apparatus 100 may provide the content 310 used to guide a breathing method of the object or content for mental stability.

[0083] Moreover, in response to a posture of an object required for acquiring a good-quality medical image being predetermined (for example, abdomen capture, heart capture, etc.), as illustrated in FIG. 3, the content providing apparatus 100 may select and provide the content 320 used to guide the posture of the object.

[0084] Moreover, as illustrated in FIG. 3, before starting to capture a medical image, the content providing apparatus

**100** may provide the content **330** used to display a time remaining until starting the capture.

**[0085]** FIG. 4 illustrates a method of providing content on the basis of body information of an object, according to an related to capture embodiment.

**[0086]** As illustrated in FIG. 4, the content providing apparatus **100** may provide content **470** for mitigating stress of an object on the basis of body information related to the object.

**[0087]** The object may be in a state of tension due to a strange environment, noise of a medical apparatus, or an uncomfortable posture, in capturing a medical image. The object may receive stress due to an anxiety of exposure to radioactivity or a strong magnetic field for a long period of time. The stress increases a heart rate of the object, and increases a skin conductance response. The stress decreases a skin temperature of the object, decreases a ratio of an alpha wave among alpha wave and beta wave components of a brainwave, and stimulates a sympathetic system in order to increase a breathing rate of the object.

**[0088]** Stress which an object feels affects a result of a medical image. For example, in response to capturing a medical image of an abdomen or a heart, a motion caused by a heartbeat and breath of an object affects a result of the medical image. Therefore, in response to a heart rate or a breathing rate being increased by stress, a degree of capturing accuracy is reduced for the medical image of the abdomen or the heart.

**[0089]** Moreover, stress which an object experiences activates a specific part of the brain of the object. Therefore, in response to performing functional magnetic resonance imaging (fMRI) capture for capturing a function of the brain for a specific condition, it is difficult to accurately capture a brain activation region.

**[0090]** To this end, the content providing apparatus **100** monitors a heart rate, a skin conductance response, a body temperature, a brainwave, and a breathing rate of an object, and in response to a determination that stress of the object increases, or in response to the object being in an excited state, the content providing apparatus **100** may select and provide content used to mitigate the stress of the object or content used to stabilize a heartbeat of the object.

**[0091]** The content providing apparatus **100** may measure a blood pressure, a body temperature, a brainwave, breath, or an ECG of an object which is collected with a blood pressure measurer **410**, a body temperature measurer **420**, a brainwave measurer **430**, a breath measurer **440**, and an ECG measurer **450**. In response to a determination based on the measured body information of the object that stress of the object increases, or in response to a determination that a heart rate **480** of the object is equal to or higher than a predetermined reference value, the content providing apparatus **100** may provide content used to decrease the stress of the object or content used to stabilize a heartbeat of the object.

**[0092]** The content used to decrease the stress of the object or the content used to stabilize a heartbeat of the object may be audio content such as a sound of nature or a sound of meditation. Also, the content may be video content such as an image of a natural landscape. The video content may include a moving image such as gymnastics **470** for inducing a deep breath of the object or decreasing a heart rate.

**[0093]** FIG. 5 illustrates a method of providing content used to stabilize a breath of an object, according to an exemplary embodiment.

**[0094]** As illustrated in FIG. 5, when a breath of an object measured by the breath measurer **440** is irregular, the content providing apparatus **100** may select and provide content used to stabilize the breath of the object or content **530** used to guide the breath of the object.

**[0095]** The content providing apparatus **100** may receive information **520** related to the breath of the object from the breath measurer **440** attached to the object. In response to a determination that the breath of the object is irregular, the content providing apparatus **100** may determine content used to adjust the breath of the object because adjusting the breath of the object is required. In other words, the content providing apparatus **100** may provide the content used to stabilize the breath of the object or the content **530** used to guide the breath of the object.

**[0096]** The content providing apparatus **100** may continuously monitor the information **520** related to the breath of the object so as to stabilize the breath of the object, in the middle of capturing a medical image in addition to before capturing a medical image.

**[0097]** FIG. 6 is a flowchart of a method of changing a capture protocol or content to provide on the basis of information related to a state of an object, according to an exemplary embodiment.

**[0098]** In operation **S610**, the content providing apparatus **100** may acquire information related to a capture protocol.

**[0099]** The capture protocol may include a captured part, a capture direction, a pulse sequence, and a parameter. The pulse sequence denotes continuation of an RF pulse that is repeatedly applied from an MRI apparatus to an object. The order of capture and a posture which the object needs to make may be determined according to the capture protocol.

**[0100]** The content providing apparatus **100**, as described above, may receive from a database the information related to the capture protocol.

**[0101]** In operation **S620**, the content providing apparatus **100** may determine guide content to be provided to an object on the basis of the acquired information related to the capture protocol.

**[0102]** For example, the content providing apparatus **100** may select content used to guide a breath of the object according to execution of the capture protocol, in capturing a medical image of an abdomen or heart of the object. A description on this will be made below with reference to FIG. 7.

**[0103]** Moreover, the content providing apparatus **100** may select content used to guide a posture of the object according to the captured part or the capture direction. A description on this will be made below with reference to FIG. 8.

**[0104]** In operation **S630**, the content providing apparatus **100** may output the determined guide content. The output of the content is as described above with reference to FIG. 2, and thus, a detailed description thereof is not provided.

**[0105]** In operation **S640**, the content providing apparatus **100** may acquire information related to a state of the object.

**[0106]** The information related to the state of the object may denote a state of the object associated with the guide content which is output in operation **S630**. For example, in response to the guide content being content for guiding the breath or posture of the object, the acquired information

related to the state of the object may be information related to the breath or posture of the object.

[0107] In operation S650, the content providing apparatus 100 may compare the state of the object with a state required by the guide content, and when a difference between the two states is equal to or greater than a certain range, the content providing apparatus 100 may determine a degree of accuracy of a medical image to be low.

[0108] For example, in capturing a medical image of the abdomen of the object, in response to content for guiding a breath according to the capture protocol being provided, the content providing apparatus 100 may receive information related to a breath state of the object to determine the breath state. In response to a determination that the received breath state and the guided state are similar to within a certain range, the content providing apparatus 100 may determine a degree of accuracy of the medical image of the abdomen to be high.

[0109] Moreover, in response to content for guiding a posture according to the capture protocol being provided, the content providing apparatus 100 may acquire information related to the posture of the object. In response to a determination that the guided posture and the acquired posture are similar to within a certain range, the content providing apparatus 100 may determine a degree of capturing accuracy to be high.

[0110] In operation S660, the content providing apparatus 100 may change the capture protocol or the guide content on the basis of the determined degree of accuracy.

[0111] In response to the degree of accuracy being determined as low, the content providing apparatus 100 may again execute a previously executed capture protocol. Alternatively, in response to the degree of accuracy being determined as low, the content providing apparatus 100 may change a capture protocol which enables the object to be more easily captured, and provide content based on the changed capture protocol. Alternatively, in response to the degree of accuracy being determined as high, the content providing apparatus 100 may change a current capture protocol to a capture protocol which has a higher degree of accuracy and enables quick capture, and provide content to the object which is used to induce a high-level breath stop time and posture.

[0112] For example, in response to a degree of capturing accuracy for the abdomen being determined as high, the content providing apparatus 100 may change a current capture protocol to a capture protocol which enables a larger quantity to be captured through a one-time scan, and provide content based on the changed capture protocol, thereby shortening a total capture time.

[0113] FIG. 7 illustrates a method of providing content used to guide a breath of an object according to a capture protocol, according to an exemplary embodiment.

[0114] In a general capture of an abdomen or a heart, artifacts may be added to a medical image due to a breath of an object. In order to reduce the number of artifacts, the object should stop a breath for several seconds to several minutes in capturing the abdomen or the heart. Generally, a user of a medical apparatus commands the object to stop a breath from a start to an end of a one-time scan.

[0115] As illustrated in FIG. 7, the content providing apparatus 100 may provide content 720 to 750 used to guide a breath to an object on the basis of a capture protocol for an abdomen or a heart.

[0116] Capture of a medical image of the abdomen or heart may include a plurality of scans. Therefore, the content providing apparatus 100 may provide content inducing stop of a breath, before one scan is started, and provide content inducing a convenient breath in response to the one scan being ended.

[0117] The content providing apparatus 100 may provide the content 720 that induces the object to stop a breath. The content providing apparatus 100 may provide a time for which the object should maintain a breath stop state according to the capture protocol. The content providing apparatus 100 may provide the content 730 that induces the object to breathe in or out.

[0118] Moreover, the content providing apparatus 100 may receive state information related to the breath of the object from the breath measurer 440, and provide a breath state as the content 740 of the object and information as the content 750 related to how well the object performs a required breathing method.

[0119] Moreover, as illustrated in FIG. 6, the content providing apparatus 100 may receive the state information related to the breath of the object from the breath measurer 440 to predict a degree of accuracy of an abdomen image of the object. The content providing apparatus 100 may change the capture protocol or the guide content on the basis of the predicted degree of accuracy.

[0120] FIG. 8 illustrates a method of providing content used to guide a posture of an object according to a capture protocol, according to an exemplary embodiment.

[0121] As illustrated in FIG. 8, the content providing apparatus 100 may provide content 810 indicating a posture which an object should make according to execution of a capture protocol.

[0122] Moreover, as described above with reference to FIG. 6, the content providing apparatus 100 may receive information related to the posture of the object from an image recognition apparatus to predict a degree of accuracy of a captured image of the object. The content providing apparatus 100 may change the capture protocol or guide content on the basis of the predicted degree of accuracy.

[0123] FIG. 9 illustrates a method of providing content used to induce sleep of an object, according to an exemplary embodiment.

[0124] A patient or a child having claustrophobia or panic disorder may refuse or find it hard to undergo an MRI or CT capture in a narrow space. Due to this, a sleeping capture in which a sleeping pill is used is preferably performed.

[0125] As illustrated in FIG. 9, the content providing apparatus 100 may provide content for inducing sleep of an object. The content for inducing sleep may include a hypnosis image 910 for inducing the object to sleep or music 920 for inducing sleep.

[0126] FIG. 10 illustrates a method of providing content used to test stress, according to an exemplary embodiment.

[0127] As illustrated in FIG. 10, the content providing apparatus 100 may provide content for increasing a heart rate of an object or content for causing mental stress of the object.

[0128] In a patient, who is not able to perform physical exercise or is unable to increase a heart rate to a predetermined reference through exercise, a heart stress test using drugs may be performed. In response to a certain level of stress being applied to a human body, a mental stress test for sensing a physical change may be performed.

[0129] The content providing apparatus 100 may provide content to the object, enabling the stress test.

[0130] The content providing apparatus 100 may determine the content to provide on the basis of a heart state 1020 of the object that is measured by the ECG measurer 450. For example, in response to the heart rate of the object being equal to or lower than a predetermined reference, the content providing apparatus 100 may provide content 1030 for more increasing the heart rate of the object.

[0131] FIG. 11 illustrates a method of providing content for fMRI capture, according to an object embodiment.

[0132] As illustrated in FIG. 11, the content providing apparatus 100 may provide fMRI test content on the basis of an fMRI capture protocol and a response of an object.

[0133] The content providing apparatus 100 may provide fMRI content on the basis of the fMRI capture protocol. For example, in a case of fMRI that captures an activity region of the brain that is associated with a recognition ability of the object, the content providing apparatus 100 may provide content to the object, used to stimulate a recognition sense of the object.

[0134] Moreover, the content providing apparatus 100 may provide the fMRI content on the basis of the response of the object.

[0135] For example, the content providing apparatus 100 may receive a brainwave of the object from a brainwave measurer 1110, and provide the fMRI test content on the basis of the received brainwave. The content providing apparatus 100 may analyze the received brainwave to determine a degree of emotional stability or a degree of concentration of the object, and provide suitable content 1120 on the basis of the brainwave information.

[0136] Moreover, the content providing apparatus 100 may recognize a voice of the object or an image of the object, and provide the fMRI test content on the basis of the recognized voice or image. For example, the content providing apparatus 100 may provide a question type of test content to the object, and recognize the voice of the object in order to acquire a response. The content providing apparatus 100 may determine fMRI test content to be subsequently executed, on the basis of a response acquired from the object. The content providing apparatus 100 may recognize a motion or posture of the object, and determine fMRI test content 1130 on the basis of the recognized motion or posture.

[0137] FIG. 12 illustrates a method of providing content related to an object while capturing a medical image, according to an exemplary embodiment.

[0138] As illustrated in FIG. 12, the content providing apparatus 100 may provide content associated with an object to the object. The content associated with the object may include information about a disease of the object, information about a captured part, and a previous medical record of the object.

[0139] In FIG. 12, in response to the disease of the object being cerebral infarction, the content providing apparatus 100 may provide information 1210 related to the cerebral infarction or content 1220 for preventing the cerebral infarction.

[0140] FIG. 13 illustrates a method of providing information related to the capture of a medical image to an object, according to an to the object embodiment.

[0141] As illustrated in FIG. 13, the content providing apparatus 100 may provide information related to a medical image, which is being currently captured, to an object while capturing the medical image.

[0142] For example, the content providing apparatus 100 may provide a capture protocol 1320 which is being currently executed, a capture protocol 1330 to be executed later, a currently captured part, information related to a currently captured slice, an estimated end time 1340 of capture, a time 1350 remaining until the capture is ended, and information related to a capture protocol including the order of capture. Also, the content providing apparatus 100 may provide a medical image 1310 of an object for which capture is completed to date.

[0143] The content providing apparatus 100 may display a pulse sequence as information related to current capture, and display a degree of execution of capture for a currently captured slice image.

[0144] The content providing apparatus 100 may provide content to the object associated with a general medical image capture operation such as an MRI or a CT capture. The content providing apparatus 100 may provide content to the object associated with a cause of noise which occurs in an MRI capture.

[0145] Moreover, the content providing apparatus 100 may provide entertainment content, such as music, a movie, a game, and the Internet, to the object in capturing a medical image.

[0146] The content providing apparatus 100 according to an exemplary embodiment may recognize a voice of the object to provide content based on a condition.

[0147] For example, the content providing apparatus 100 may analyze a voice tone of the object in order to analyze an emotional state of the object in fMRI capture, and provide content used to test a function of the brain on the basis of the analyzed emotional state. The content providing apparatus 100 may analyze previous and next contexts of the recognized voice to provide fMRI content suitable for the object's intent in the fMRI capture.

[0148] The content providing apparatus 100 according to an exemplary embodiment may analyze a specific gesture of the object to select content to be provided to the object.

[0149] In capturing a medical image, a posture of an object is fixed, and a motion of the object is limited. Therefore, it is difficult for the object to control content provided by the content providing apparatus 100. Accordingly, the content providing apparatus 100 may recognize a gesture of the object, and provide content to the object on the basis of the recognized gesture.

[0150] For example, the content providing apparatus 100 may recognize a specific hand motion of an object, or recognize a motion of an eyeball of the object, thereby receiving a content control signal from the object. Also, the content providing apparatus 100 may recognize a specific motion of the feet, the head, or fingers as well as the hands or the eyes, thereby receiving the content control signal from the object.

[0151] The content providing apparatus 100 according to an exemplary embodiment may recognize a facial expression of an object to select content to be provided to the object. The content providing apparatus 100 may recognize the facial expression of the object to determine a current emotional state and a degree of inconvenience which the object experiences in capture. Therefore, the content pro-

viding apparatus **100** may provide entertainment content or content (which is used to increase the understanding of a currently captured medical image) for capture of the medical image on the basis of the determined emotional state or degree of inconvenience of the object.

[0152] FIG. 14 illustrates a content providing apparatus **100** for providing information related to the capture of a medical image to an object, according to an exemplary embodiment.

[0153] The content providing apparatus **100** according to an exemplary embodiment may include an information acquiring unit **110**, e.g., an information acquirer, a content determining unit **120**, e.g., a content determiner, and an output unit **130**, e.g. an output.

[0154] FIG. 15 illustrates a content providing apparatus for providing information related to the capture of a medical image to an object, according to another exemplary embodiment.

[0155] As illustrated in FIG. 15, the content providing apparatus **100** may further include a control unit **140**, e.g., a controller, a capture unit **150**, e.g., a capturer, a memory unit **160**, e.g., a memory and an image processing unit **170**, e.g., an image processor.

[0156] The information acquiring unit **110** according to an exemplary embodiment may include a state information acquirer **112**, which acquires information related to a state of an object, and a capture protocol acquirer **114** that acquires information related to a capture protocol.

[0157] However, the illustrated elements are not all essential elements. The content providing apparatus **100** may be implemented with more or less elements than the number of illustrated elements.

[0158] Hereinafter, the elements will be described sequentially.

[0159] The state information acquirer **112** may acquire information related to a state of an object.

[0160] The state information acquirer **112** may include at least one of a temperature sensor that senses a body temperature of an object, a blood pressure sensor that senses a blood pressure of the object, an ECG measurer (ECG electrodes) that senses a heart state of the object, a respiratory monitoring bellows that senses a breath state of the object, a brainwave measurer (EEG electrodes) that senses a brainwave of the object, and an MRI apparatus that captures an MR image of the object.

[0161] The state information acquirer **112** may include an electromyogram (EMG) measurer, an electrooculogram (EOG) measurer, an electroretinogram (ERG) measurer, a galvanic skin response (GSR) measurer, and a phonocardiogram (PCG) measurer.

[0162] Moreover, the state information acquirer **112** may include at least one of a voice recognition sensor, which recognizes a voice of an object, and an image recognition sensor that recognizes a posture and motion of the object.

[0163] The capture protocol acquirer **114** may acquire a capture protocol used to capture the object. The capture protocol acquirer **114** may acquire the capture protocol from a memory included in the content providing apparatus **100**. Also, the capture protocol acquirer **114** may acquire the capture protocol from a picture archiving and communication system (PACS) server, an electronic medical record (EMR) server, a personal health record (PHR) server, or a radiology information system (RIS) server.

[0164] The content determining unit **120**, e.g., a content determiner, may determine content to be provided to the object, on the basis of the acquired information.

[0165] The content determining unit **120** may determine the content to be provided to the object, on the basis of at least one of information about the acquired state of the object and information about the capture protocol.

[0166] The output unit **130** may output the determined content.

[0167] The output unit **130** may be included in a medical image capturing apparatus that captures a medical image of the object. For example, the output unit **130** may be disposed at an inner wall of a gantry of an MRI apparatus or a CT apparatus. Also, the output unit **130** may be disposed in a bore of the MRI apparatus or the CT apparatus.

[0168] Moreover, the output unit **130** may be an element that is movable according to a position of the object. For example, the content providing apparatus **100** may automatically adjust a position of the output unit **130** according to the object's view.

[0169] The output unit **130** is for outputting an audio signal or a video signal, and may include a display unit, e.g., a display, such as a screen, or a sound output unit such as a speaker.

[0170] The display unit may display and output information obtained through processing by the content providing apparatus **100**. For example, the display unit may display a user interface (UI) or a graphical user interface (GUI) associated with content.

[0171] Moreover, the display unit may display a UI or a GUI associated with an operation of a medical image capturing apparatus, and display a medical image.

[0172] In addition, the display unit may include at least one of a liquid crystal display (LCD), a thin film transistor-liquid crystal display, an organic light-emitting diode (OLED) display, a flexible display, a 3D display, an electrophoretic display, and a transparent display.

[0173] Moreover, the content providing apparatus **100** may include at least one or more display units depending on an implementation type of the content providing apparatus **100**.

[0174] The sound output unit may output audio data. Also, the sound output unit may receive a content-related acoustic signal from the content providing apparatus **100**. The sound output unit may include a speaker and a buzzer.

[0175] The control unit **140**, e.g., a controller, according to an exemplary embodiment may control the information acquiring unit **110**, the content determining unit **120**, the output unit **130**, the control unit **140**, the capture unit **150**, e.g., the capturer, the memory unit **160**, e.g., memory, and the image processing unit **170**, e.g., the image processor.

[0176] The capture unit **150** may receive a signal, which is transferred from the object or passes through the object, to collect data used to acquire a medical image. The image processing unit **170** may generate a medical image of the object by using the data collected by the capture unit **150**.

[0177] The capture unit **150** or the image processing unit **170** may include an MRI apparatus, a CT apparatus, or an X-ray apparatus.

[0178] The memory unit **160** may store content related to the capture of a medical image, and store information related to the state of the object or information about a capture protocol. The memory unit **160** may include at least one type of storage medium of a flash memory, a hard disk, a

multimedia micro card, a card type memory (a secure digital (SD) card, an extreme digital (XD) card, or the like), random access memory (RAM), static random access memory (SRAM), read-only memory (ROM), an electrically erasable programmable read-only memory (EEPROM), and a programmable read-only memory (PROM).

[0179] The content providing apparatus 100 may include a communicator (not shown). The communicator may include a wireless communicator, a short-distance communicator, and a wired communicator. The content providing apparatus 100 may receive information related to the capture of a medical image or object-related content from an external server through the communicator (not shown).

[0180] The content providing apparatus 100 may include a user input unit, e.g., user input (not shown). The user input unit (not shown) may denote a means for inputting data used for a user to control the content providing apparatus 100. For example, the user input unit may include a keypad, a dome switch, a touch pad (for example, a contact capacitive type, a press resistive type, an infrared sensing type, a surface ultrasonic conductive type, an integration tension measurement type, and a piezo effect type), a jog wheel, and a jog switch, but is not limited thereto.

[0181] It should be understood that the exemplary embodiments described therein should be considered in a descriptive sense only and not for purposes of limitation. Descriptions of features or aspects within each exemplary embodiment should typically be considered as available for other similar features or aspects in other exemplary embodiments.

[0182] While one or more exemplary embodiments of the present invention have been described with reference to the figures, it will be understood by those of ordinary skill in the art that various changes in form and details may be made therein without departing from the spirit and scope of the present invention as defined by the following claims.

What is claimed is:

1. A method of providing content related to capture of a medical image of an object, the method comprising:

acquiring at least one of information related to a state of the object and information related to a capture protocol; determining content to be provided to the object on a basis of the acquired information; and outputting the determined content to the object.

2. The method of claim 1, wherein the information related to the state of the object includes at least one of information related to a body signal of the object, information related to a posture of the object, information related to a voice of the object, and information related to a motion of the object.

3. The method of claim 1, wherein the information related to the capture protocol includes information related to at least one of a captured part of the object, a capture direction, a pulse sequence to be used for capture, a capture purpose, precautions for capture, a capture time, and setting information before starting capture.

4. The method of claim 1, wherein the determining includes selecting content used to stabilize a breath of the object or content used to guide the breath of the object as content to be provided to the object in response to the breath of the object being irregular.

5. The method of claim 1, wherein the determining includes selecting content used to stabilize a heartbeat of the object as content to be provided to the object in response to a heart rate of the object among the information related to

the heartbeat of the object being equal to or higher than a predetermined reference value.

6. The method of claim 3, wherein the determining includes selecting at least one of content used to display a time remaining until starting capture, content used to guide a breathing method of the object before starting the capture, and content used to guide a posture of the object before starting the capture, on a basis of the setting information before starting capture.

7. The method of claim 1, wherein the determining includes selecting content used to guide a breath or a posture of the object and required according to the capture protocol.

8. The method of claim 1, wherein, the information related to the capture protocol includes information related to a capture protocol used to acquire a functional magnetic resonance (fMR) image of the object, and

the determining includes selecting content used to activate a brain of the object, on a basis of the information related to the capture protocol used to acquire the fMR image.

9. The method of claim 1, wherein, the information related to the capture protocol includes information related to a protocol used to capture an MR image of the object when performing a stress test for a heart of the object, and

the determining includes selecting content used to induce a heart rate of the object to increase, on a basis of the information related to the capture protocol.

10. The method of claim 1, wherein, the information related to the capture protocol includes information related to a capture protocol for an MR image of a sleeping state of the object, and

the determining includes selecting content used to induce the object to sleep, on a basis of the information related to the capture protocol.

11. An apparatus for providing content related to capture of a medical image of an object, the apparatus comprising: an information acquirer configured to acquire at least one of information related to a state of the object and information related to a capture protocol;

a content determiner configured to determine content to be provided to the object, on a basis of the acquired information; and

an output configured to output the determined content.

12. The apparatus of claim 11, wherein the information acquirer includes:

a state information acquirer that acquires information related to the state of the object; and

a capture protocol acquirer that acquires the information related to the capture protocol.

13. The apparatus of claim 11, wherein the information related to the body signal includes information related to at least one of a body temperature, a blood pressure, a heart rate, a breath pattern, a brainwave and muscular motion of the object.

14. The apparatus of claim 11, wherein in response to a breath of the object being irregular, the content determiner is configured to select content used to stabilize the breath of the object or content used to guide the breath of the object, as content to be provided to the object.

15. The apparatus of claim 11, wherein in response to a heart rate of the object among the information related to a heartbeat of the object being equal to or higher than a

predetermined reference value, the content determiner is configured to select content, used to stabilize the heartbeat of the object, as content to be provided to the object.

16. The apparatus of claim 13, wherein the content determiner is configured to select at least one of content used to display a time remaining until starting capture, content used to guide a breathing method of the object before starting the capture, and content used to guide a posture of the object before starting the capture on a basis of the setting information, before starting capture.

17. The apparatus of claim 11, wherein the content determiner is configured to select content used to guide a breath or a posture of the object and required according to the capture protocol.

18. The apparatus of claim 11, wherein, the information related to the capture protocol includes information related to a capture protocol used to acquire a functional magnetic resonance (fMR) image of the object, and

the content determiner is configured to select content used to activate a brain of the object, on a basis of the information related to the capture protocol used to acquire the fMR image.

19. The apparatus of claim 11, wherein, the information related to the capture protocol includes information related to a protocol used to capture an MR image of the object in response to performing a stress test for a heart of the object, and

the content determiner is configured to select content used to induce a heart rate of the object to increase or to induce the object to sleep, on a basis of the information related to the capture protocol.

20. A non-transitory computer-readable storage medium storing a program, wherein the program, when executed by a processor of a computer, causes the computer to execute the method of claim 1.

\* \* \* \* \*

专利名称(译)	用于提供与医学图像的捕获相关的内容的方法和设备		
公开(公告)号	<a href="#">US20190204398A1</a>	公开(公告)日	2019-07-04
申请号	US16/298366	申请日	2019-03-11
[标]申请(专利权)人(译)	三星电子株式会社		
申请(专利权)人(译)	SAMSUNG ELECTRONICS CO. , LTD.		
当前申请(专利权)人(译)	SAMSUNG ELECTRONICS CO. , LTD.		
[标]发明人	LEE DAE HO ZHO SANG YOUNG KIM JOON SOO		
发明人	LEE, DAE-HO ZHO, SANG-YOUNG KIM, JOON-SOO		
IPC分类号	G01R33/28 G16H40/63 A61B5/055 A61B6/00 A61B5/00		
CPC分类号	G01R33/283 G16H40/63 A61B5/055 A61B6/46 A61B5/4884 G01R33/4828 G01N24/081 G01R33/4806 A61B5/7285 G01R33/5605 A61M2021/0027 A61M2021/0044 A61M21/02 A61B6/032		
优先权	1020130094900 2013-08-09 KR		
外部链接	<a href="#">Espacenet</a> <a href="#">USPTO</a>		

摘要(译)

提供了一种提供与捕获对象的医学图像有关的内容的方法。该方法包括获取与对象的状态和与捕获协议有关的信息有关的信息，基于获取的信息确定要提供给对象的内容中的至少一个，并输出确定的内容。

