



US 20180078307A1

(19) **United States**

(12) **Patent Application Publication**
WANG

(10) **Pub. No.: US 2018/0078307 A1**
(43) **Pub. Date: Mar. 22, 2018**

(54) **SYSTEM AND METHOD FOR MAPPING THE FUNCTIONAL NERVES INNERVATING THE WALL OF ARTERIES, 3-D MAPPING AND CATHETERS FOR SAME**

A61B 5/20 (2006.01)
A61B 5/0205 (2006.01)
A61B 5/00 (2006.01)
A61B 18/00 (2006.01)
A61B 18/18 (2006.01)
A61N 1/36 (2006.01)

(71) Applicant: **SYMAP MEDICAL (SUZHOU), LIMITED**, Suzhou (CN)

(52) **U.S. Cl.**

(72) Inventor: **Jie WANG**, Englewood Cliffs, NJ (US)

CPC .. *A61B 18/1492* (2013.01); *A61B 2018/1475* (2013.01); *A61B 5/024* (2013.01); *A61B 5/04001* (2013.01); *A61B 5/201* (2013.01); *A61B 5/0205* (2013.01); *A61B 5/4836* (2013.01); *A61B 5/4893* (2013.01); *A61B 5/4833* (2013.01); *A61B 2018/00404* (2013.01); *A61B 2018/00267* (2013.01); *A61B 2018/0022* (2013.01); *A61B 2018/00202* (2013.01); *A61B 18/18* (2013.01); *A61B 2018/00434* (2013.01); *A61B 2018/00511* (2013.01); *A61B 2018/00577* (2013.01); *A61B 2018/00791* (2013.01); *A61B 2018/00839* (2013.01); *A61B 2018/00875* (2013.01); *A61B 2018/1407* (2013.01); *A61B 2018/1435* (2013.01); *A61N 1/36117* (2013.01); *A61B 5/0215* (2013.01)

(21) Appl. No.: **15/802,610**

(22) Filed: **Nov. 3, 2017**

Related U.S. Application Data

(63) Continuation of application No. 14/956,350, filed on Dec. 1, 2015, now Pat. No. 9,820,811, which is a continuation-in-part of application No. 14/691,553, filed on Apr. 20, 2015, now Pat. No. 9,375,154, which is a continuation of application No. 14/241,061, filed on Feb. 25, 2014, now Pat. No. 9,014,821, filed as application No. PCT/IB2012/054310 on Aug. 24, 2012, Continuation-in-part of application No. 15/691,768, filed on Aug. 31, 2017, which is a continuation of application No. 14/421,869, filed on Feb. 16, 2015, now Pat. No. 9,770,291, filed as application No. PCT/CN2013/082135 on Aug. 23, 2013, which is a continuation-in-part of application No. PCT/IB2012/054303, filed on Aug. 24, 2012, said application No. PCT/CN2013/082135 is a continuation-in-part of application No. PCT/IB2012/054310, filed on Aug. 24, 2012.

(Continued)

(30) **Foreign Application Priority Data**

Mar. 6, 2013 (CN) 201310070820.3

Publication Classification

(51) **Int. Cl.**

A61B 18/14 (2006.01)
A61B 5/0215 (2006.01)
A61B 5/024 (2006.01)
A61B 5/04 (2006.01)

(57)

ABSTRACT

Disclosed herein are systems and methods for locating and identifying nerves innervating the wall of arteries such as the renal artery. The present invention identifies areas on vessel walls that are innervated with nerves; provides indication on whether energy is delivered accurately to a targeted nerve; and provides immediate post-procedural assessment of the effect of energy delivered to the nerve. The methods includes evaluating a change in physiological parameters after energy is delivered to an arterial wall; and determining the type of nerve that the energy was directed to (sympathetic or parasympathetic or none) based on the evaluated results. The system includes at least a device for delivering energy to the wall of blood vessel; sensors for detecting physiological signals from a subject; and indicators to display results obtained using said method. Also provided are catheters for performing the mapping and ablating functions.

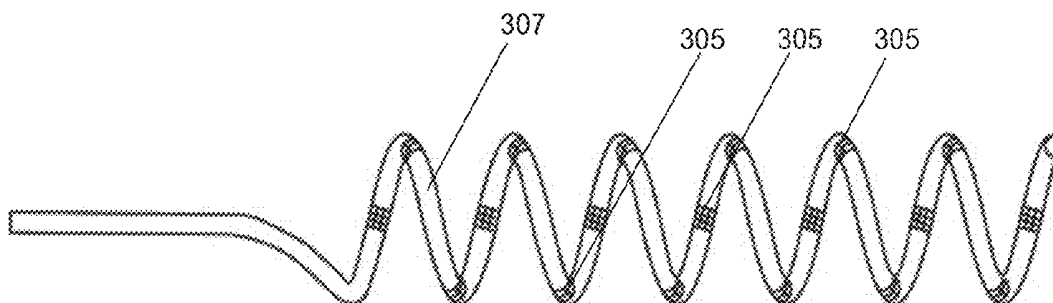

Related U.S. Application Data

(60) Provisional application No. 61/609,565, filed on Mar. 12, 2012, provisional application No. 61/527,893, filed on Aug. 26, 2011, provisional application No. 61/693,019, filed on Aug. 24, 2012, provisional ap-

plication No. 61/609,565, filed on Mar. 12, 2012, provisional application No. 61/527,893, filed on Aug. 26, 2011, provisional application No. 61/609,565, filed on Mar. 12, 2012, provisional application No. 61/527,893, filed on Aug. 26, 2011.

Figure 1

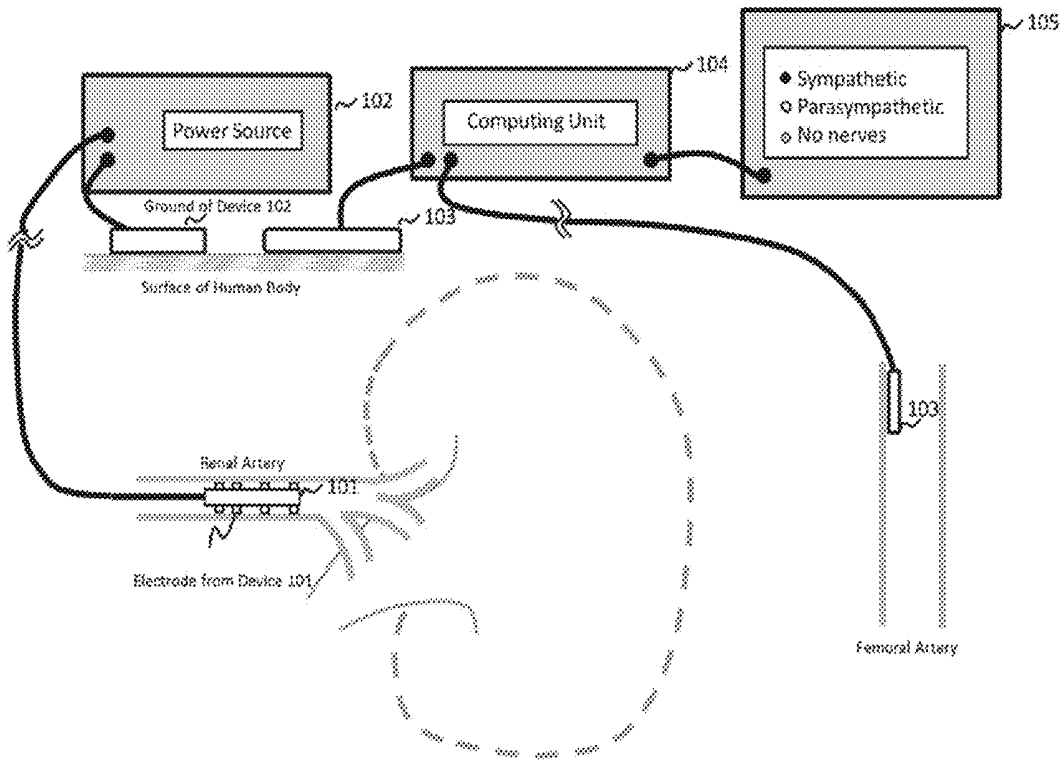

Figure 2

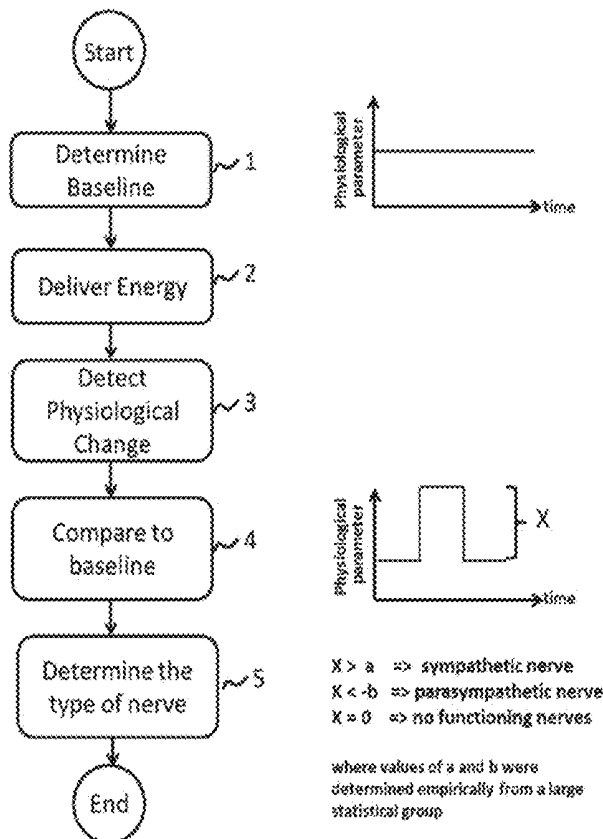

Figure 3A

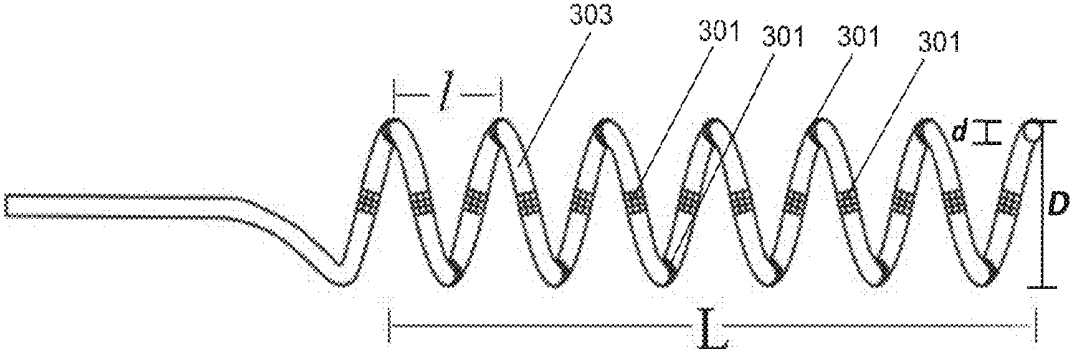

Figure 3B

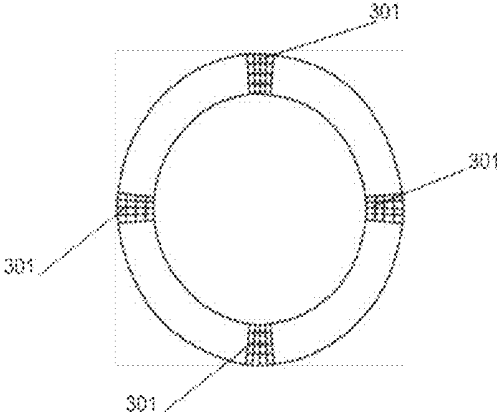

Figure 3C

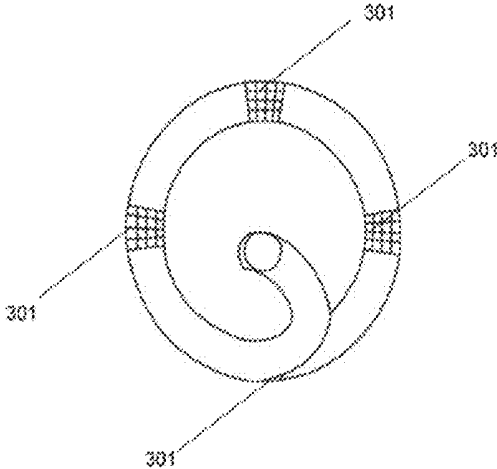

Figure 3D

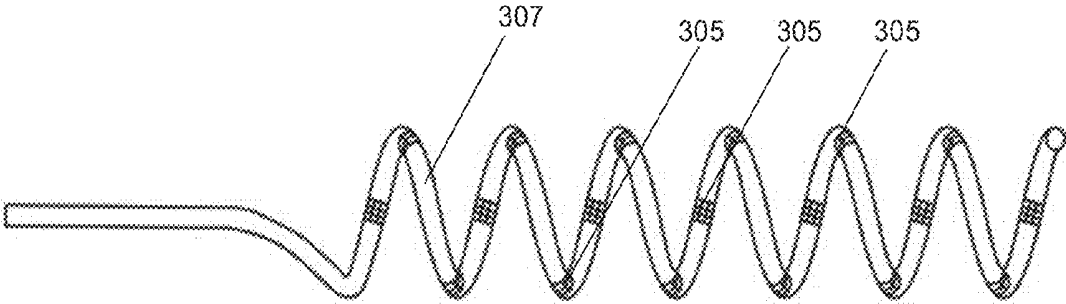

Figure 3E

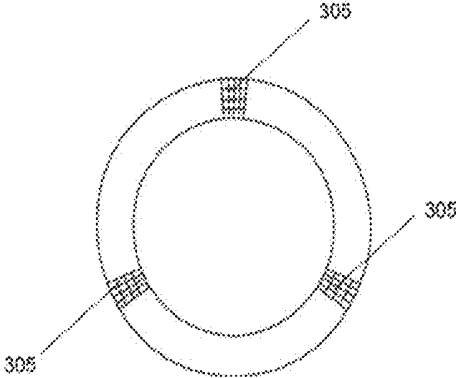

Figure 3F

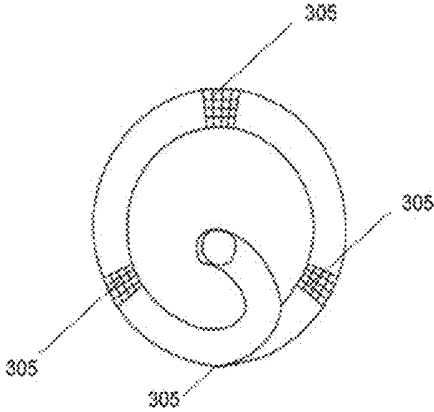

Figure 3G

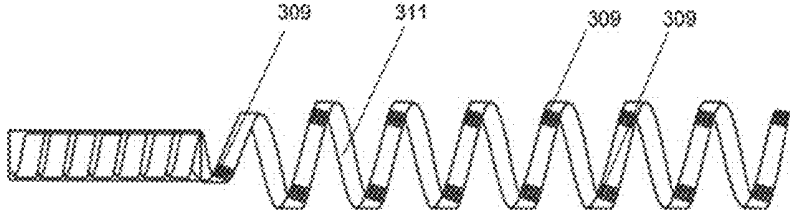

Figure 3H

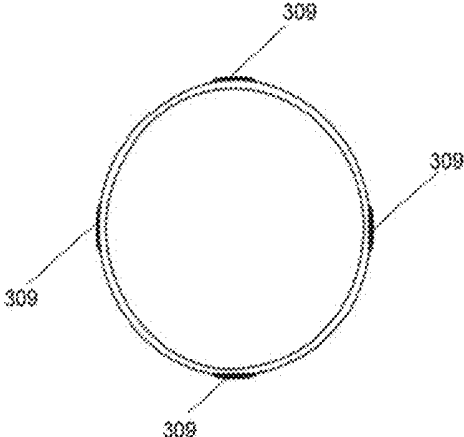

Figure 3I

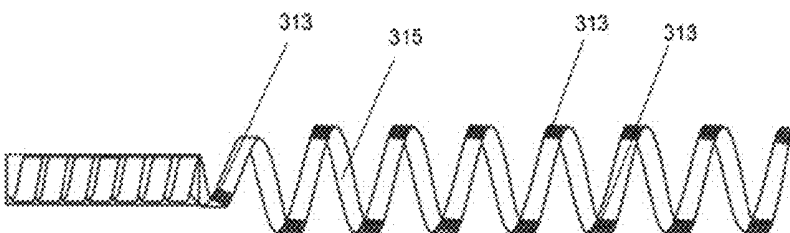

Figure 3J

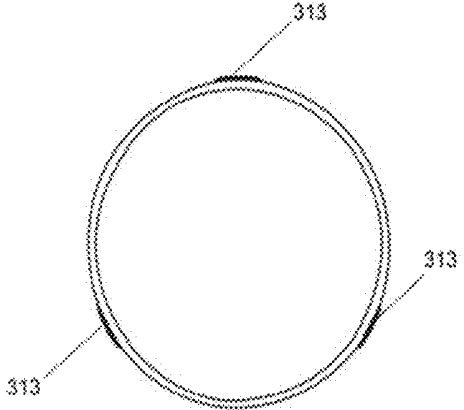

Figure 4A

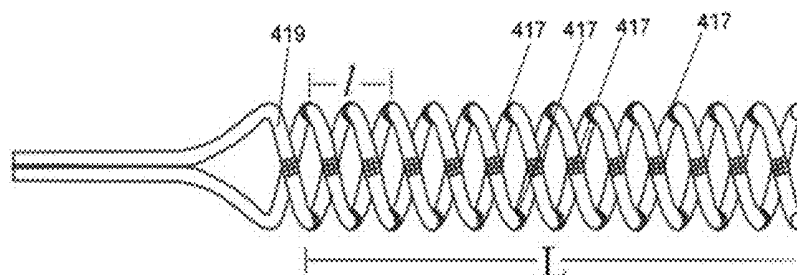

Figure 4B

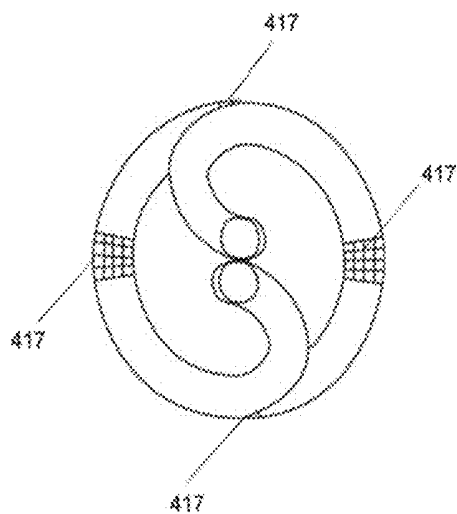

Figure 4C

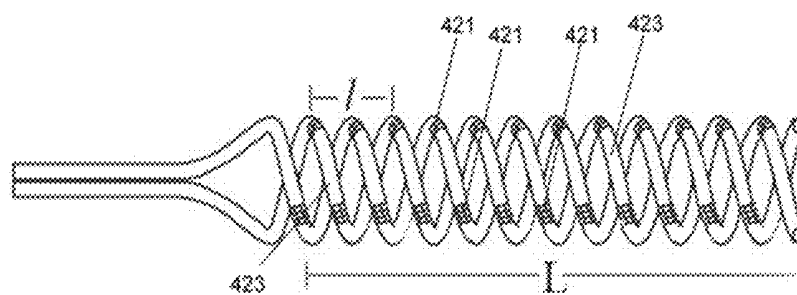

Figure 4D

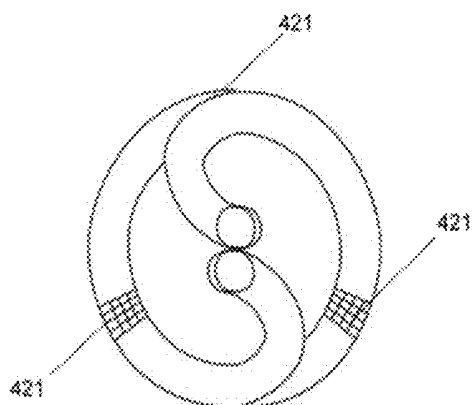

Figure 4E

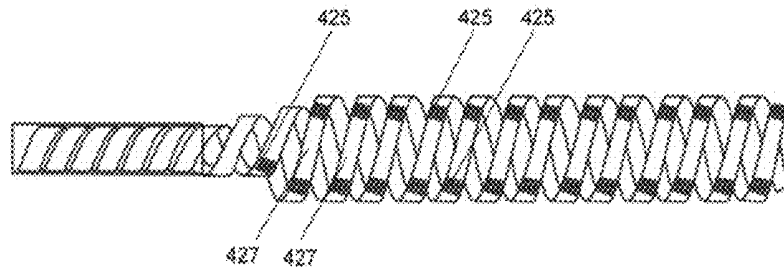

Figure 4F

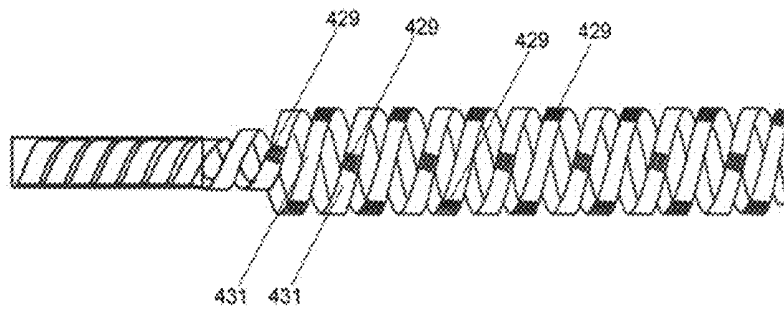

Figure 5A

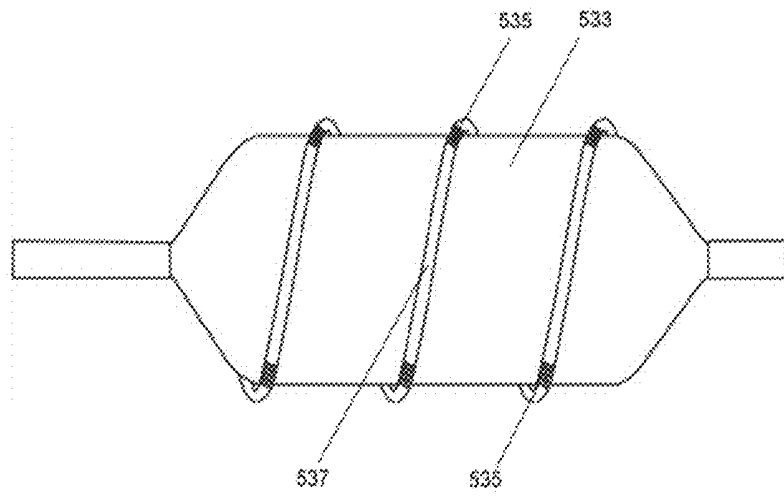

Figure 5B

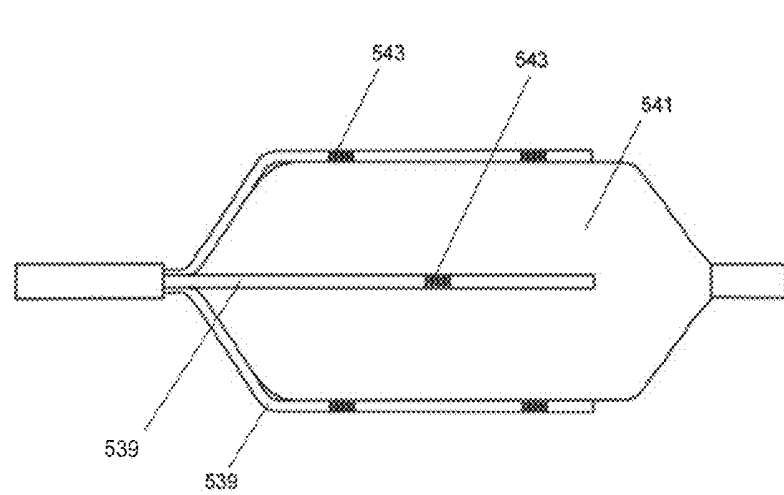

Figure 6A

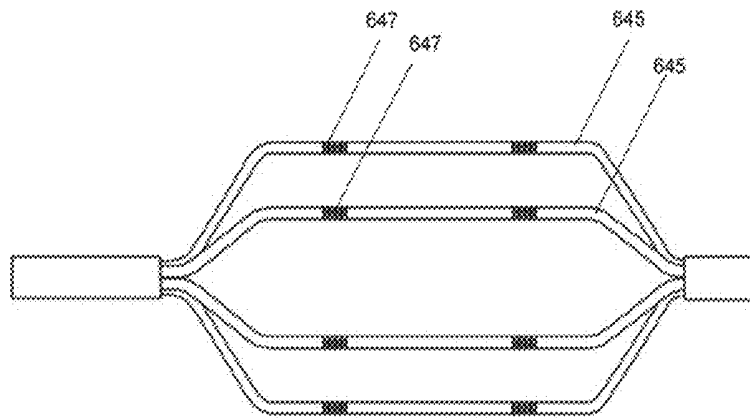

Figure 6B

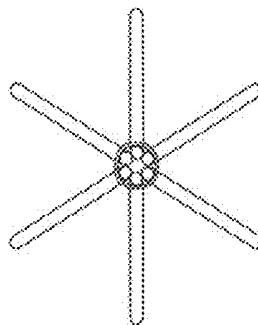

Figure 6C

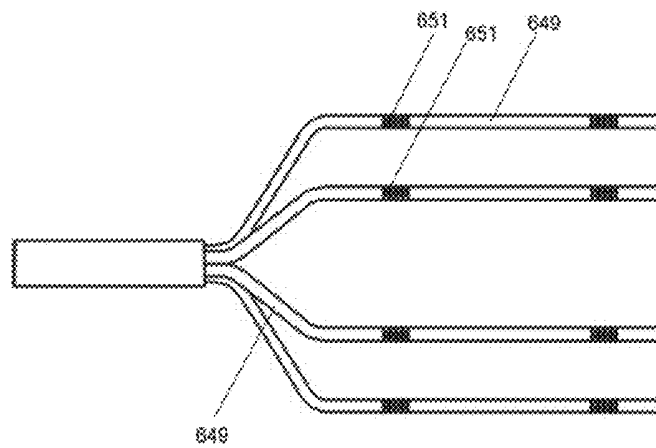

Figure 6D

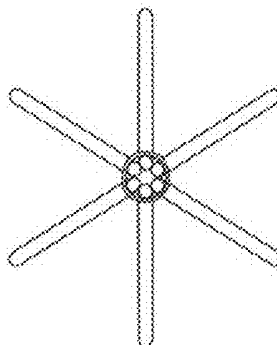

Figure 7A



Figure 7B

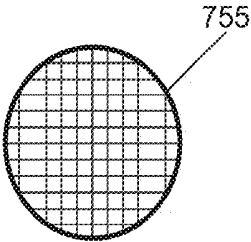

Figure 8

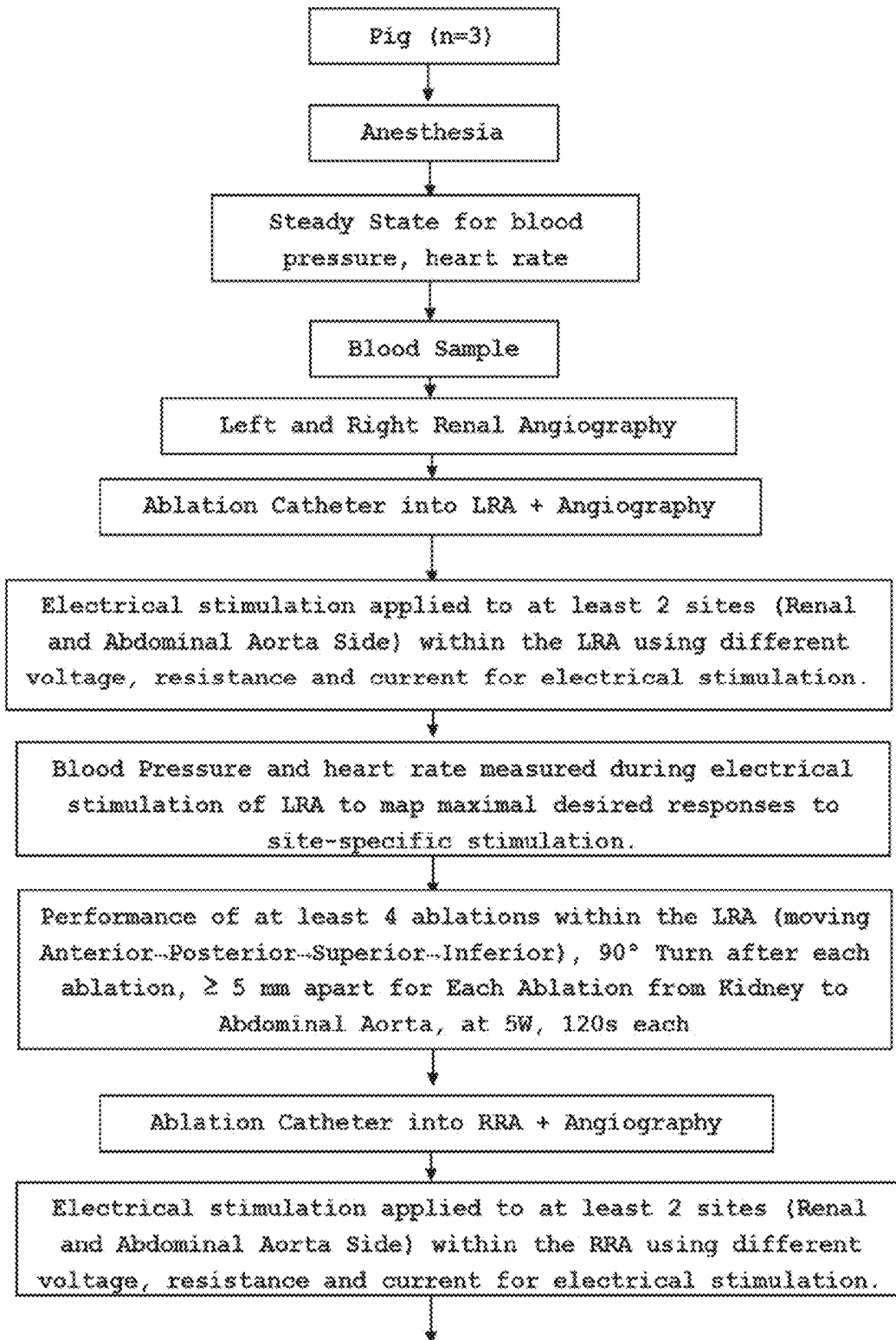

Figure 8 (Cont'd)

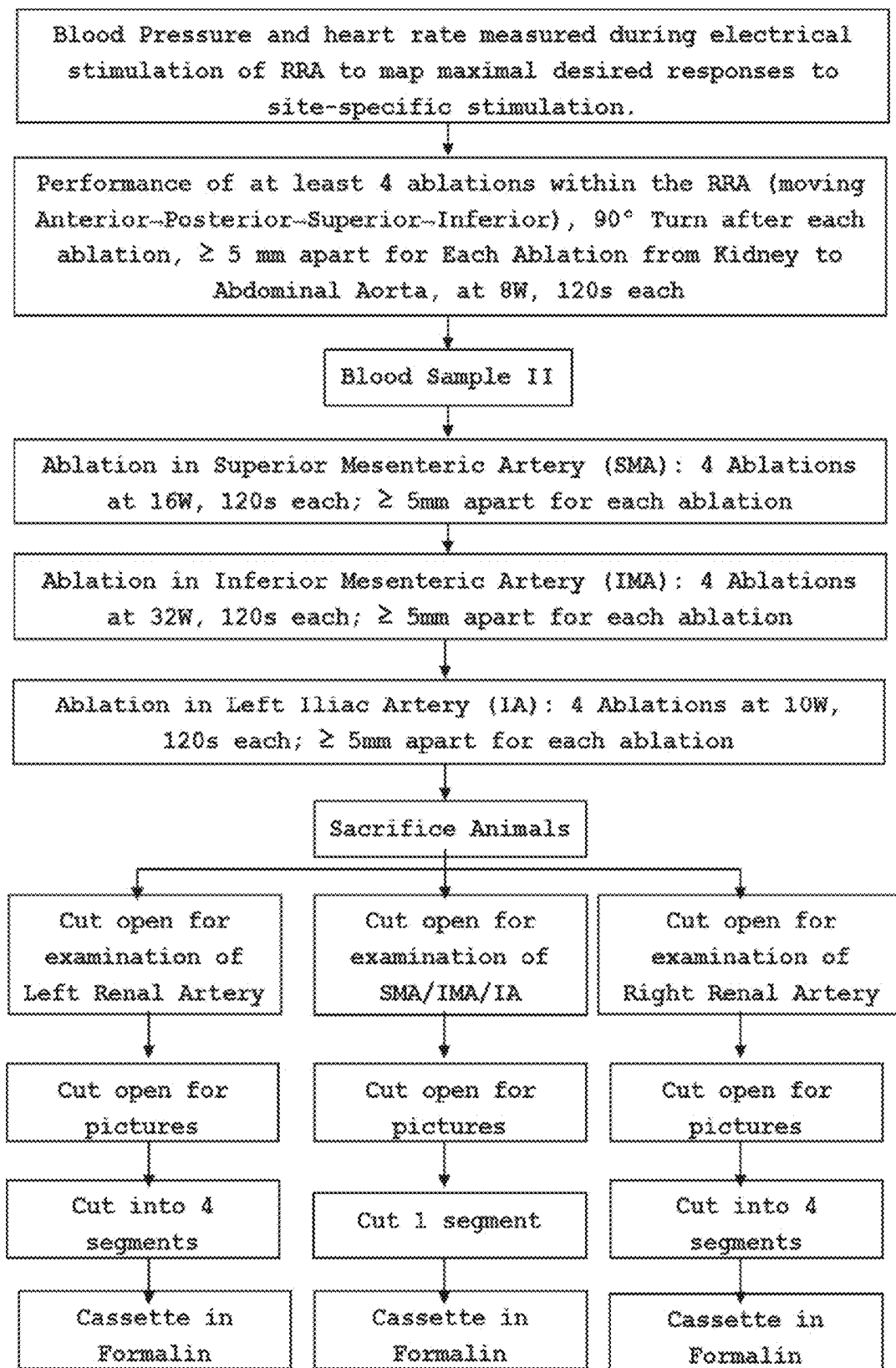

Figure 9A

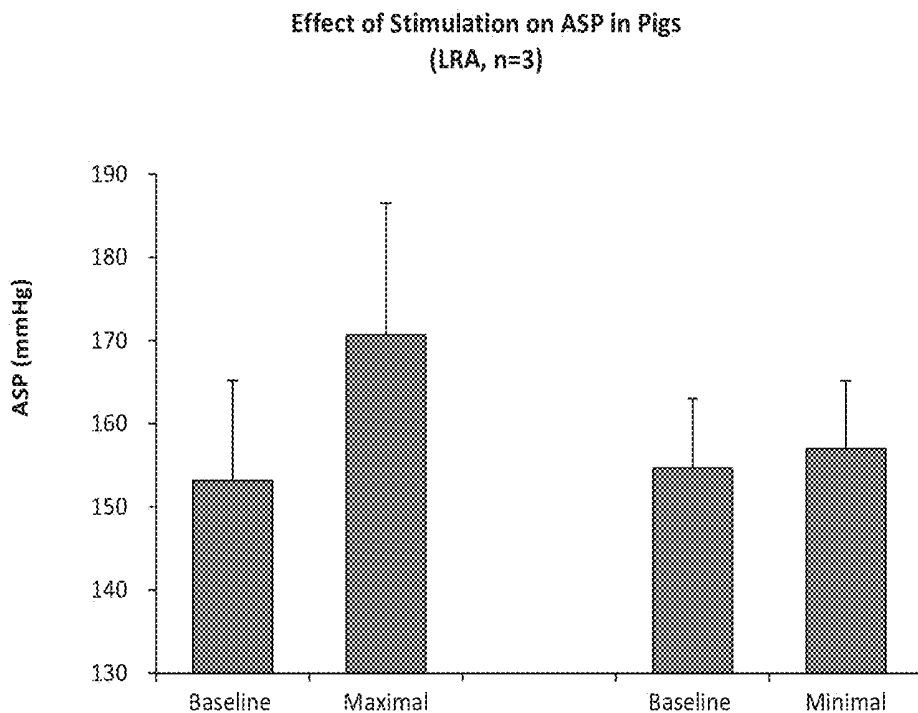

Figure 9B

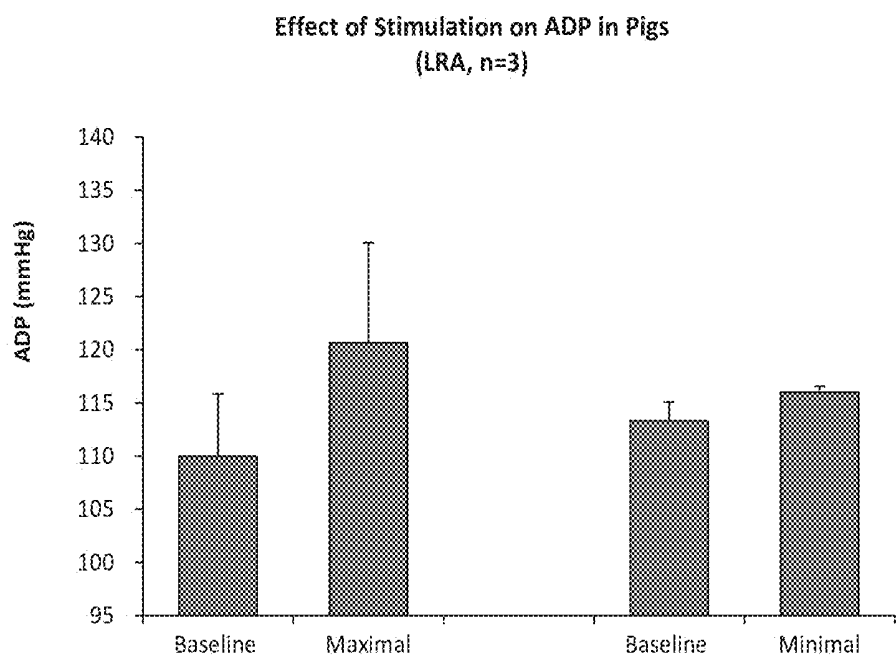

Figure 9C

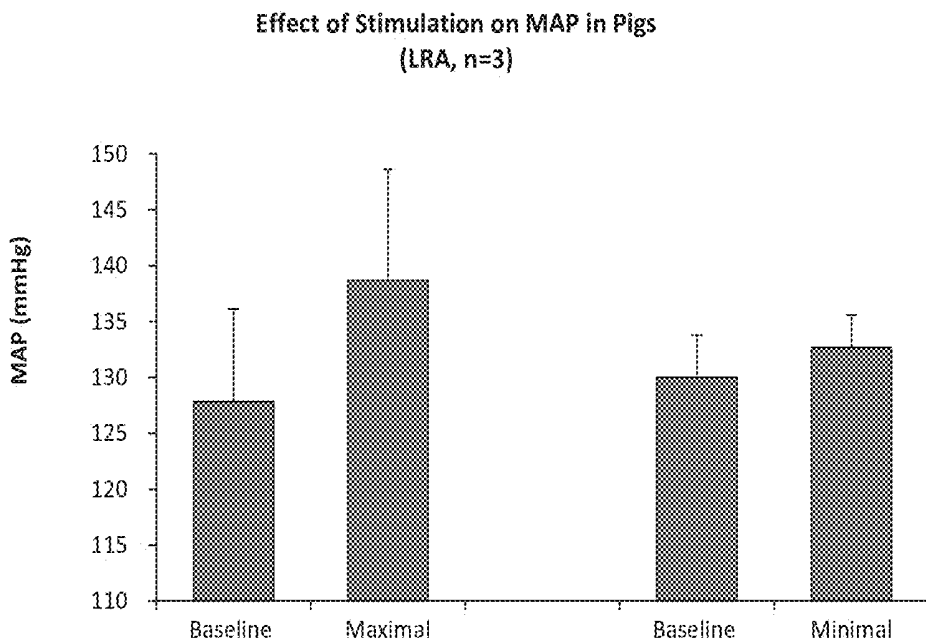

Figure 9D

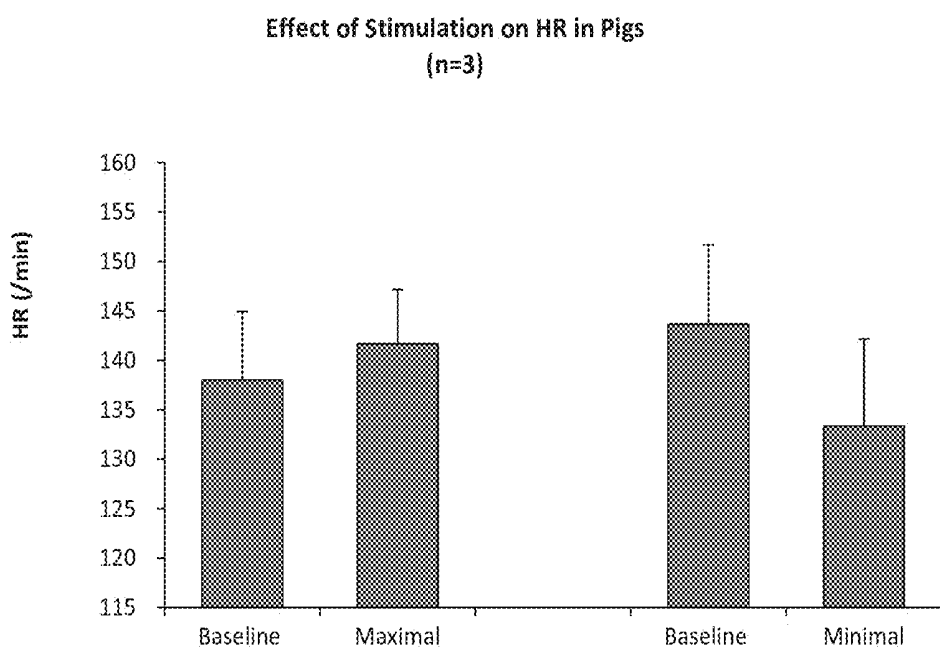

Figure 10A

Effect of Stimulation on ASP in Pigs
(RRA, n=3)

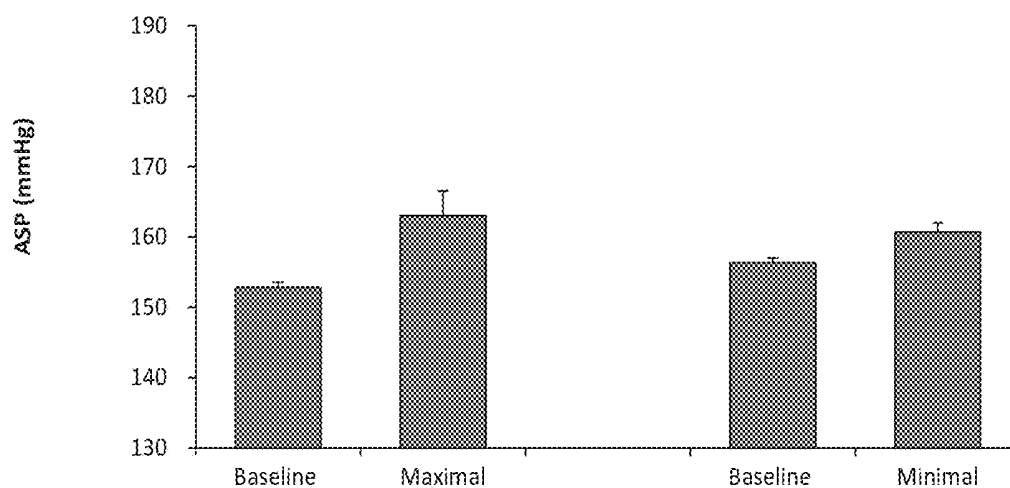

Figure 10B

Effect of Stimulation on ADP in Pigs
(RRA, n=3)

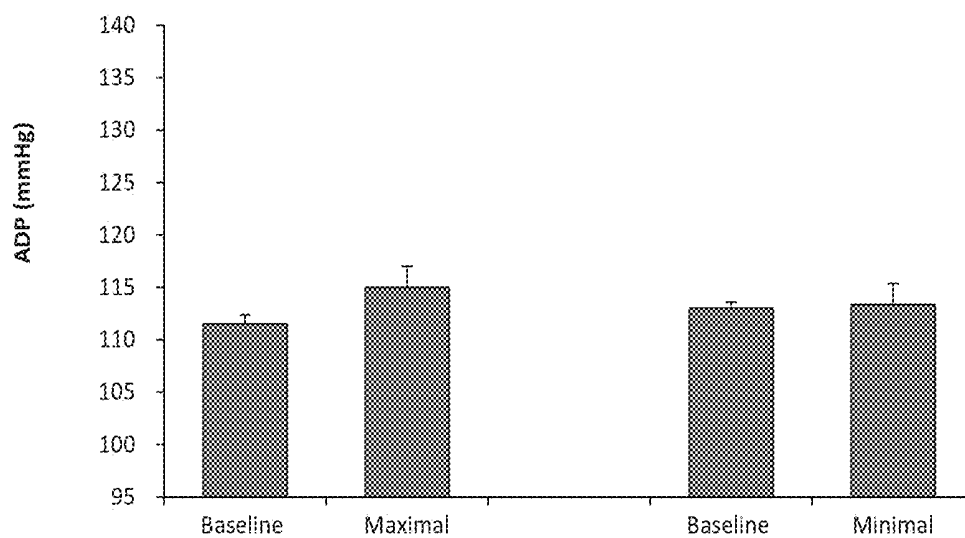

Figure 10C

Effect of Stimulation on MAP in Pigs
(RRA, n=3)

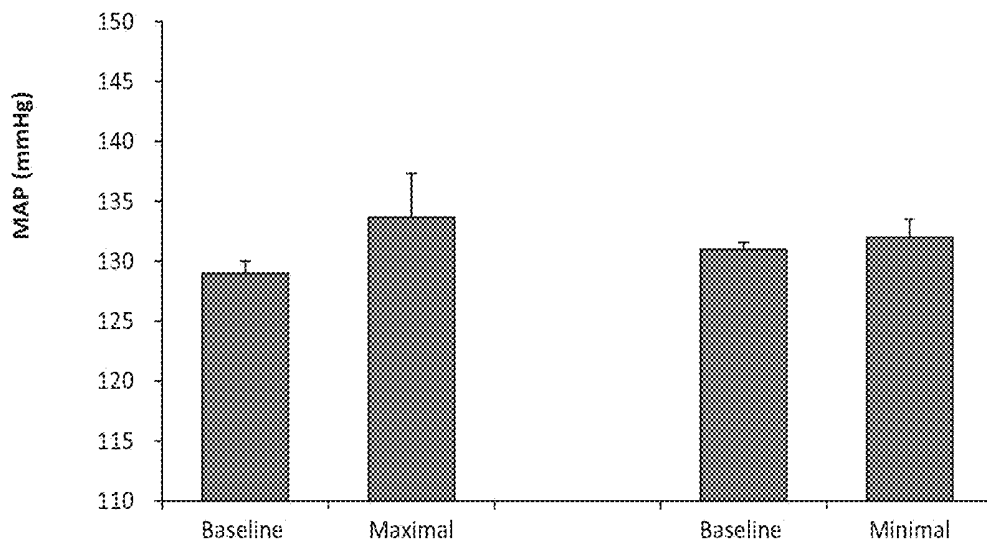

Figure 10D

Effect of Stimulation on HR in Pigs
(RRA, n=3)

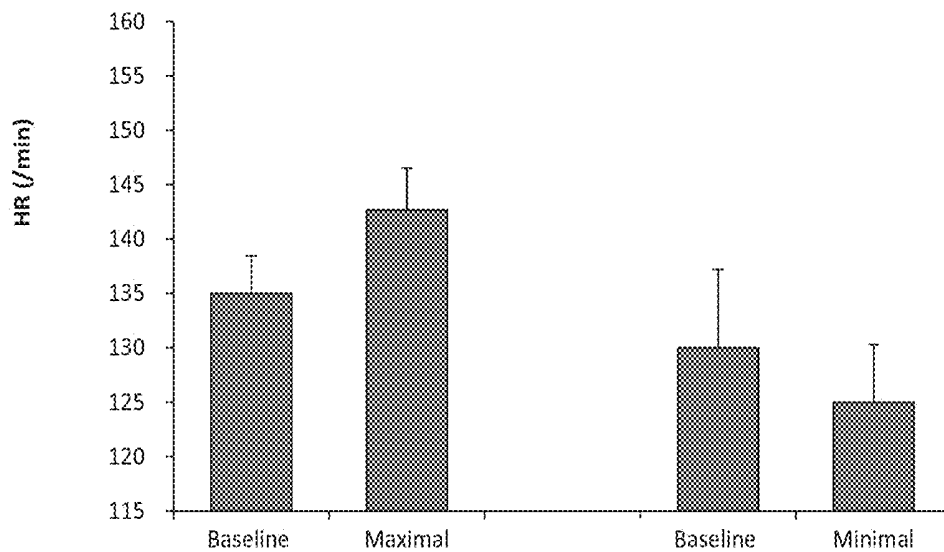

Figure 11

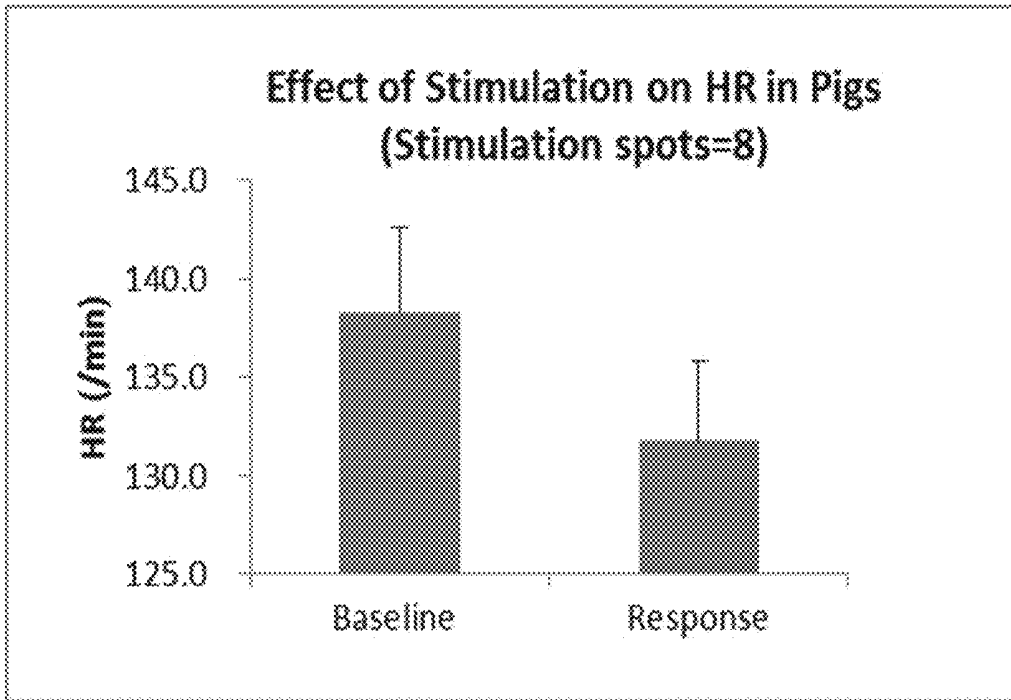

Figure 12A

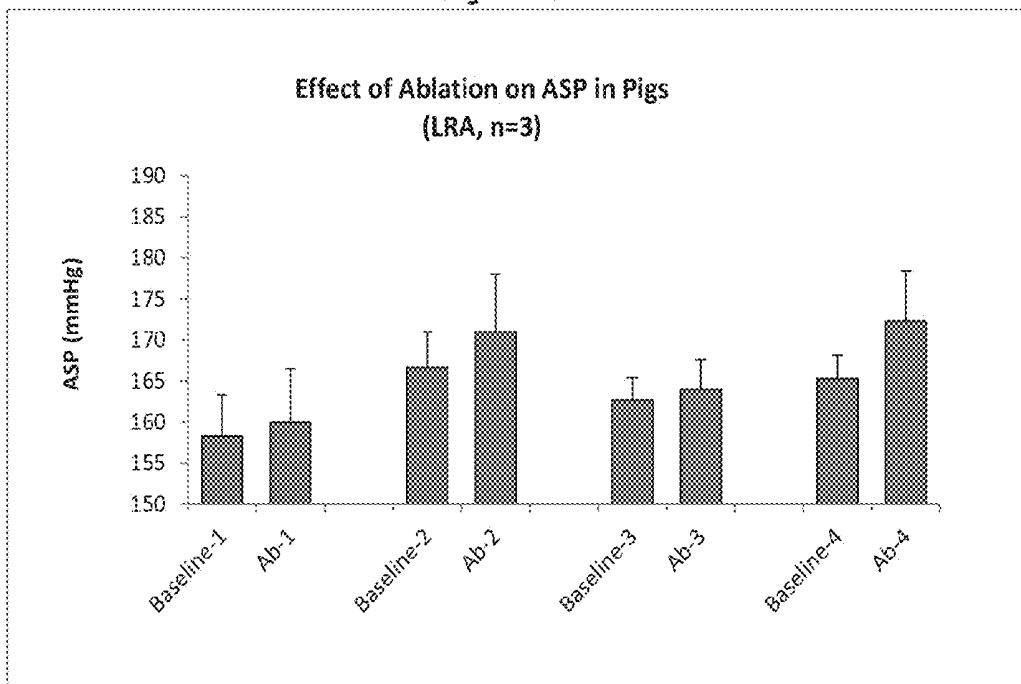

Figure 12B

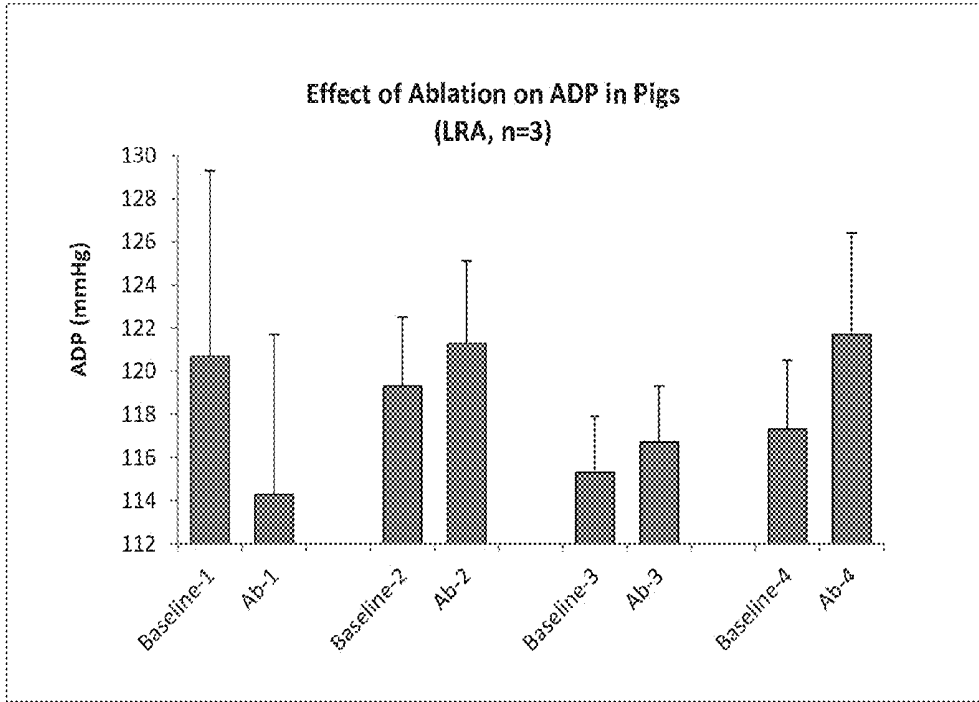

Figure 12C

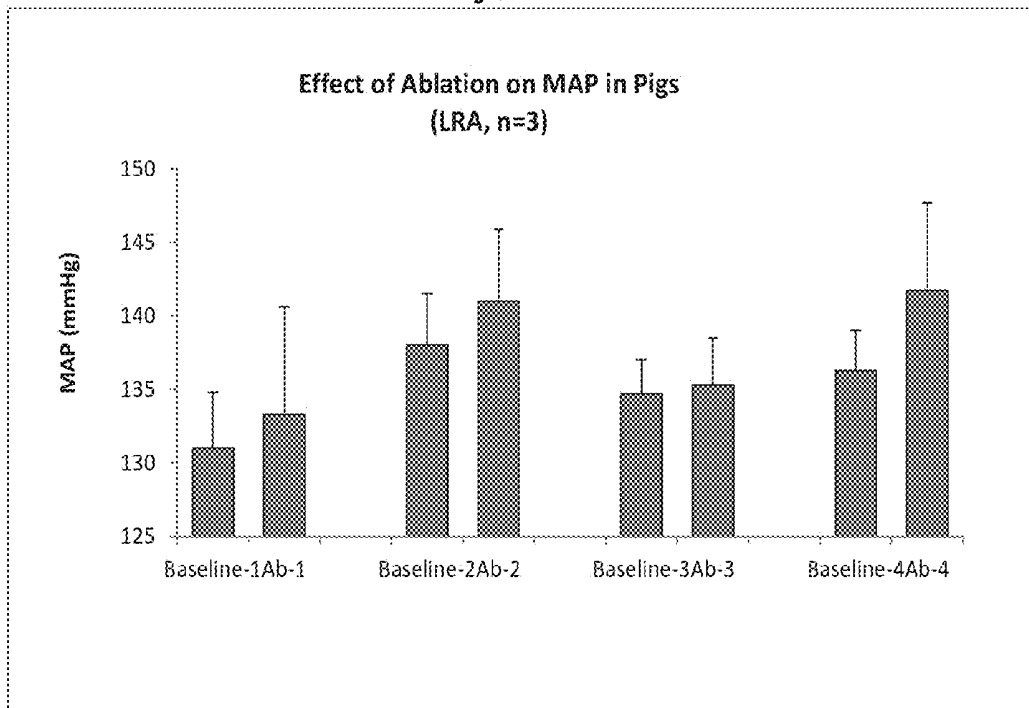

Figure 12D

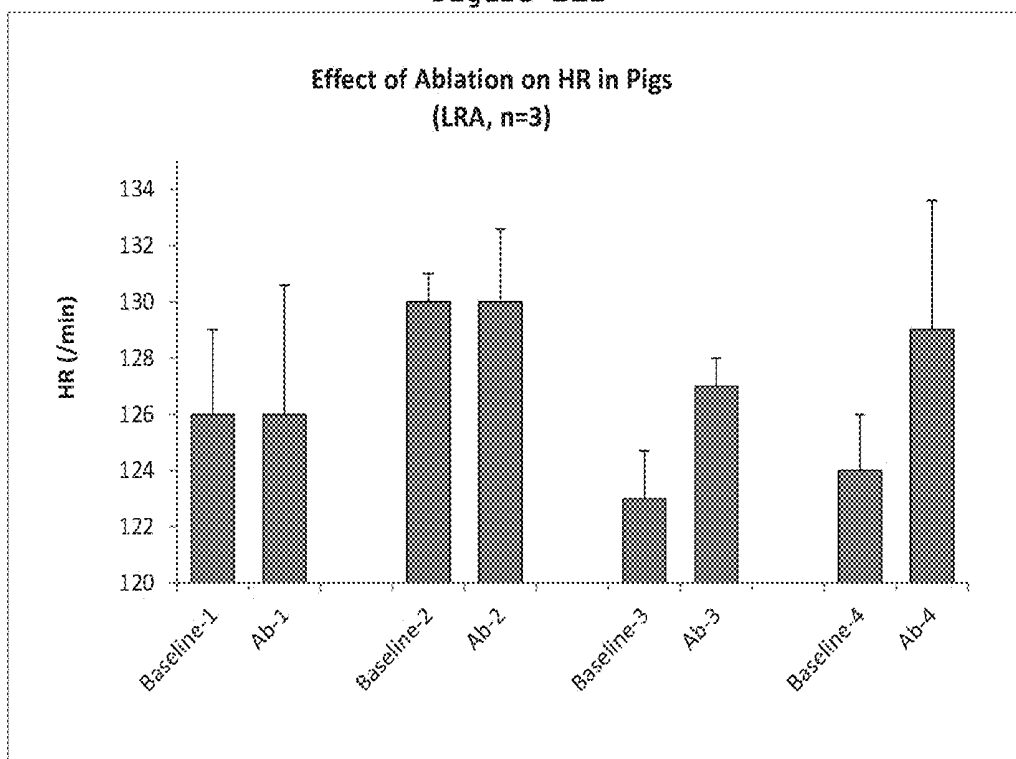

Figure 13A

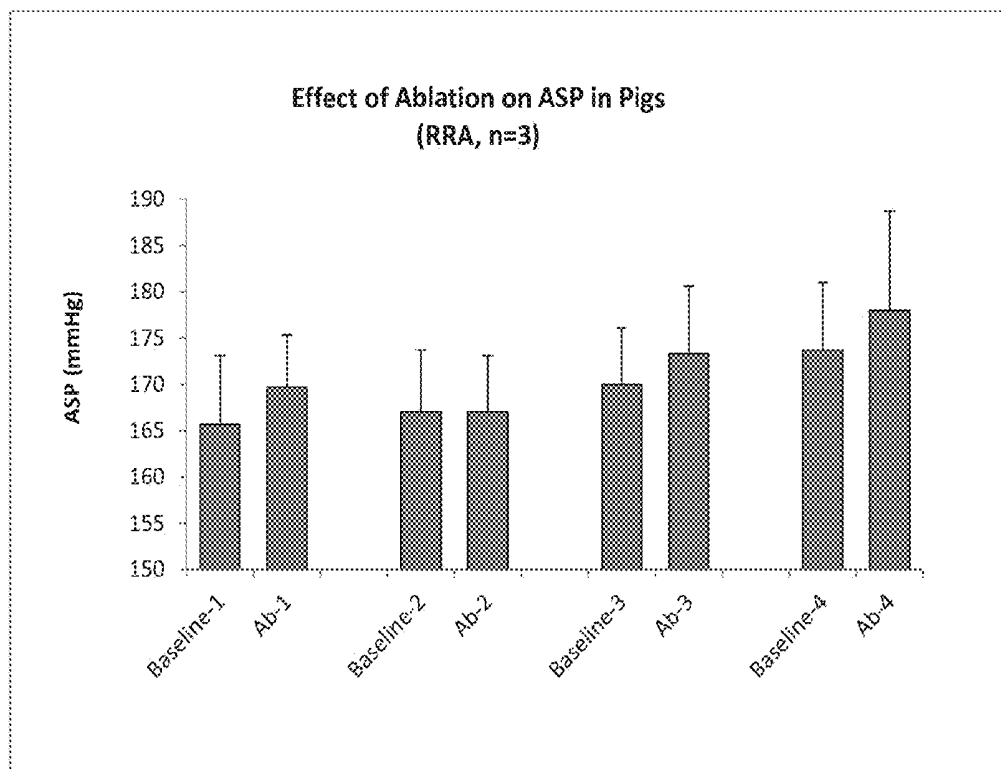

Figure 13B

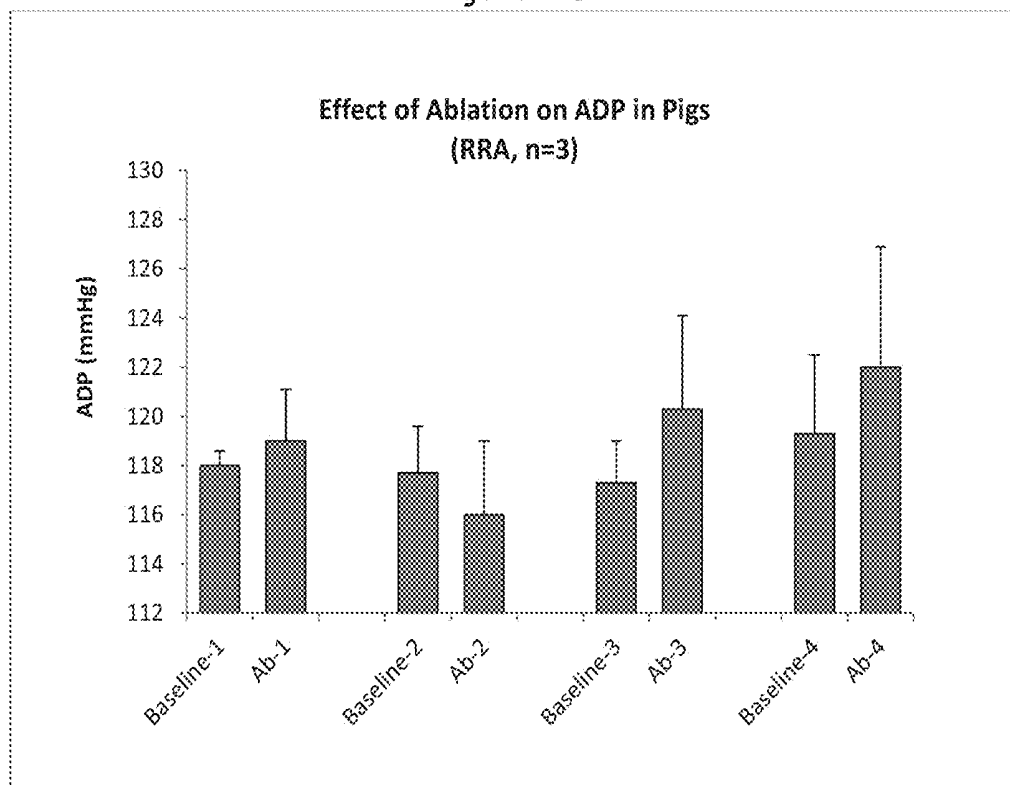

Figure 13C

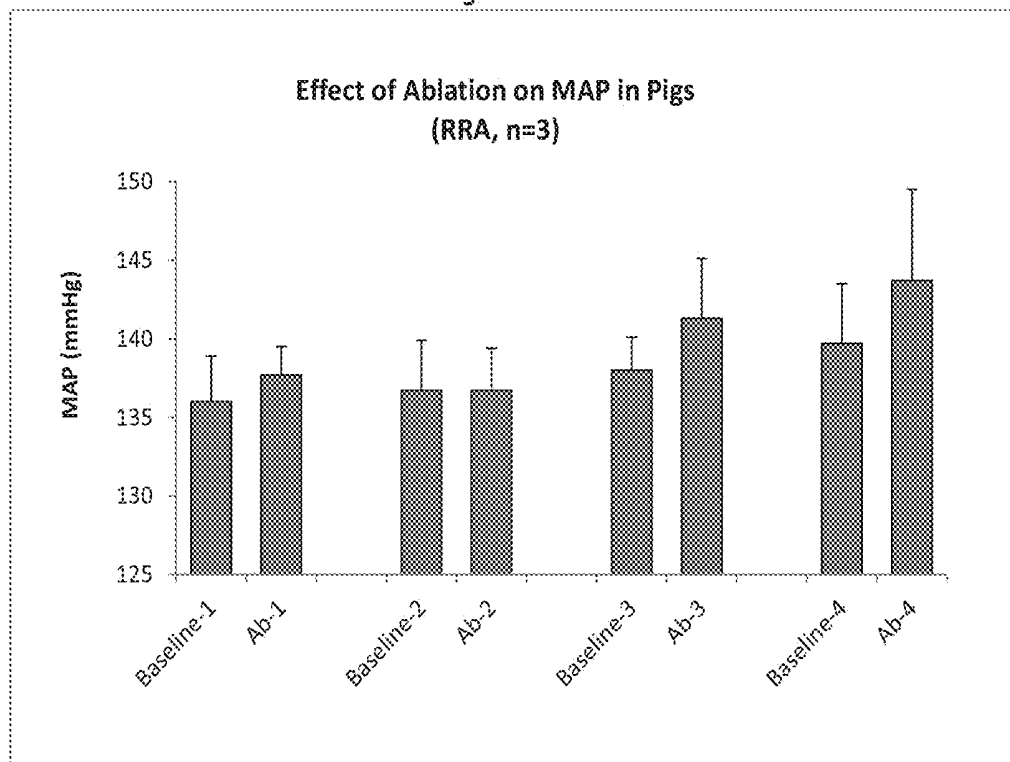

Figure 13D

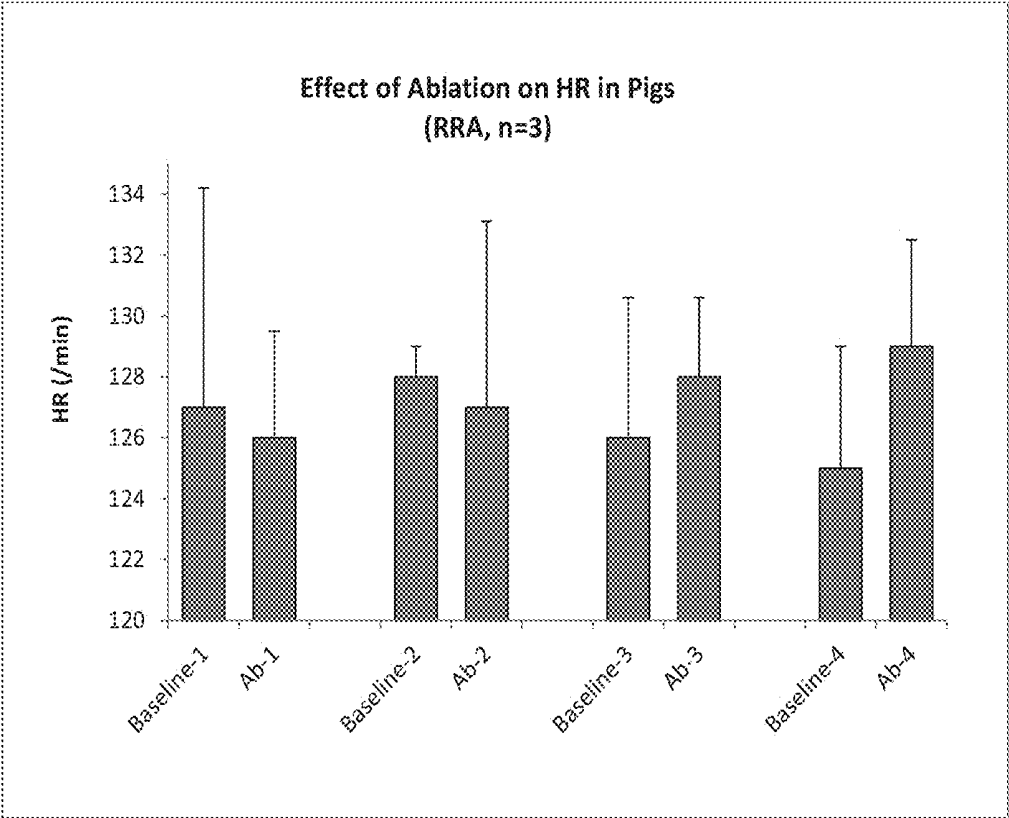

Figure 14

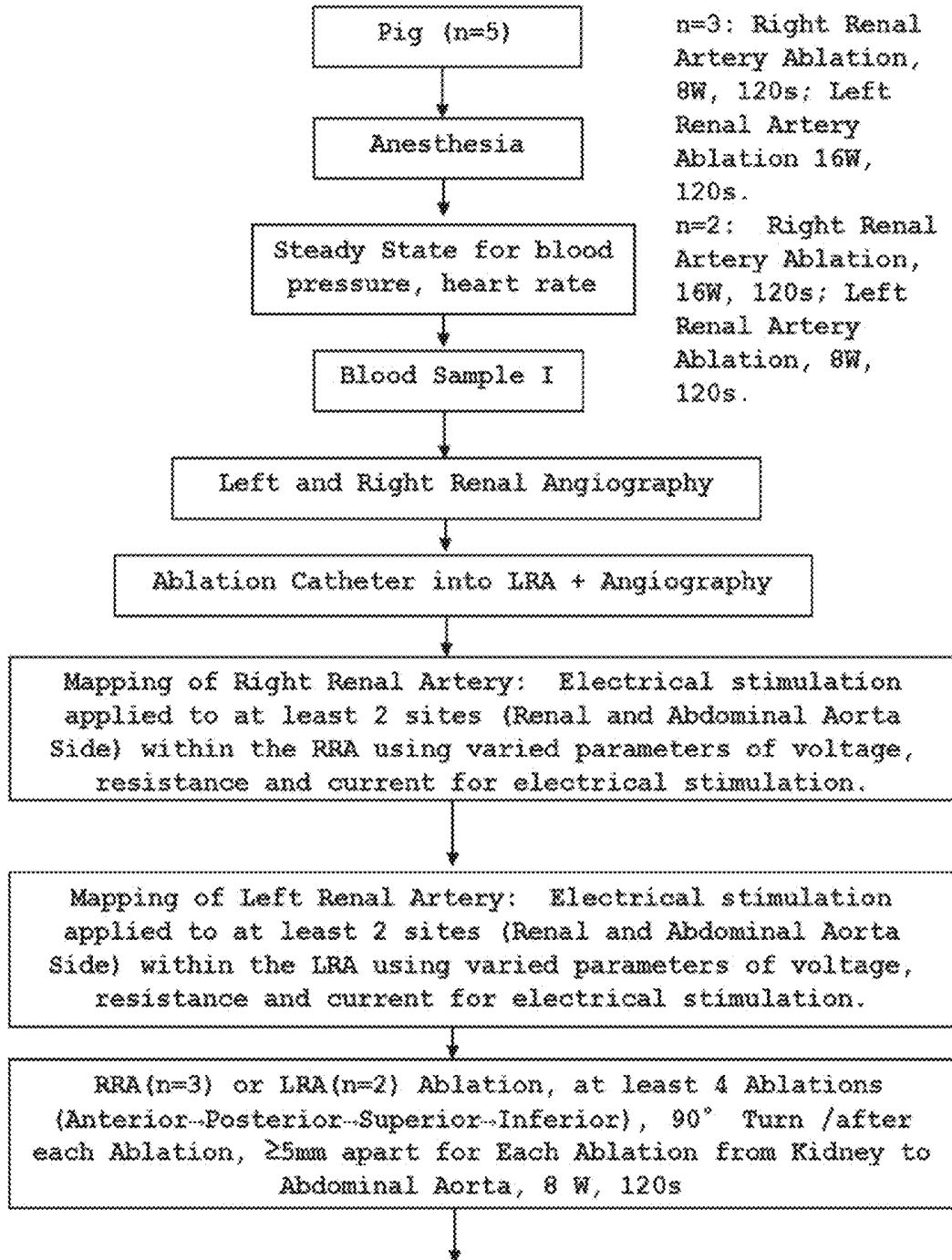

Figure 14 (Cont'd)

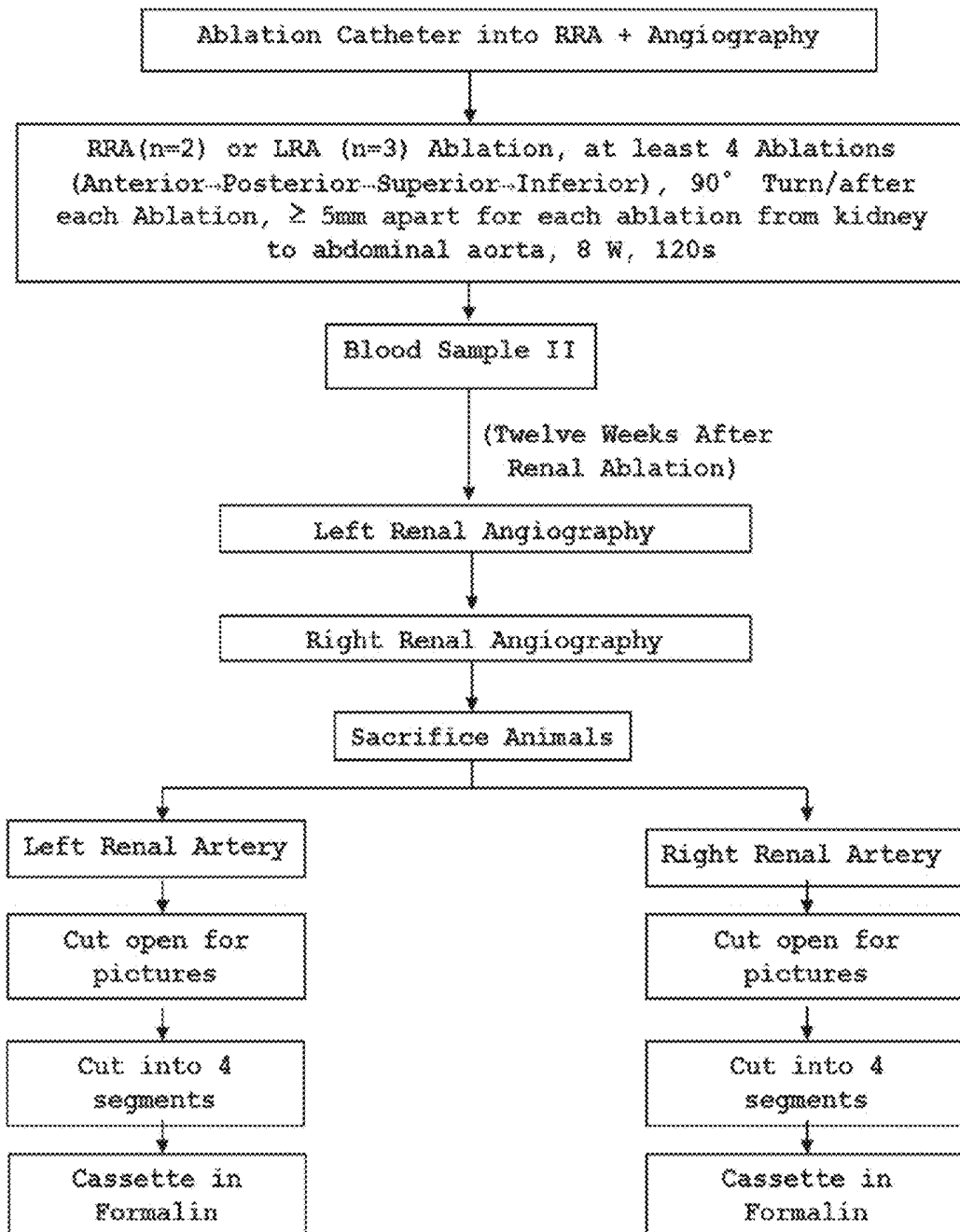
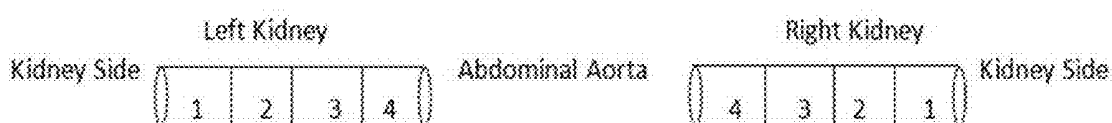

Figure 15



Histology Cassette Labeling:

LK1, LK2, LK3, LK4; RK1, RK2, RK3, RK4

Figure 16

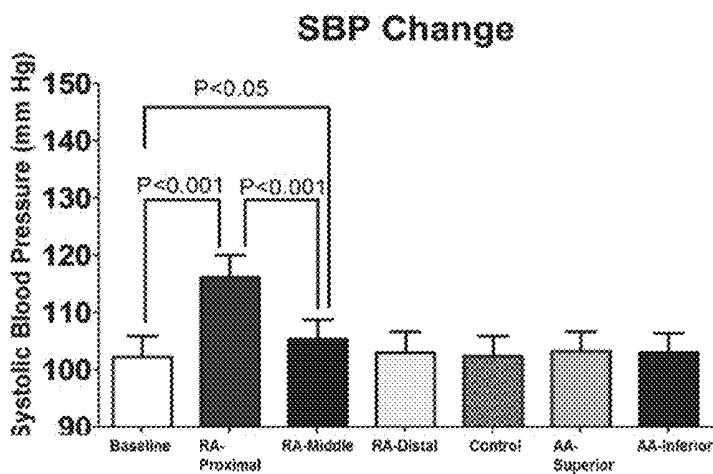

Figure 17A

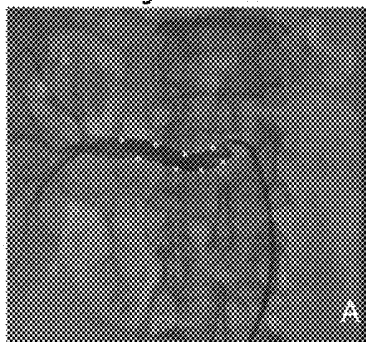

Figure 17B

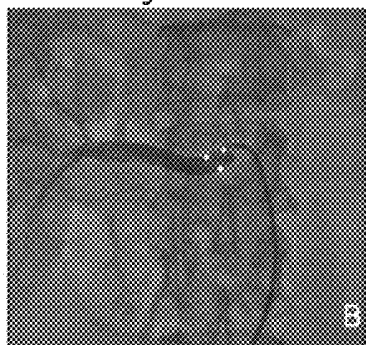

Figure 18A

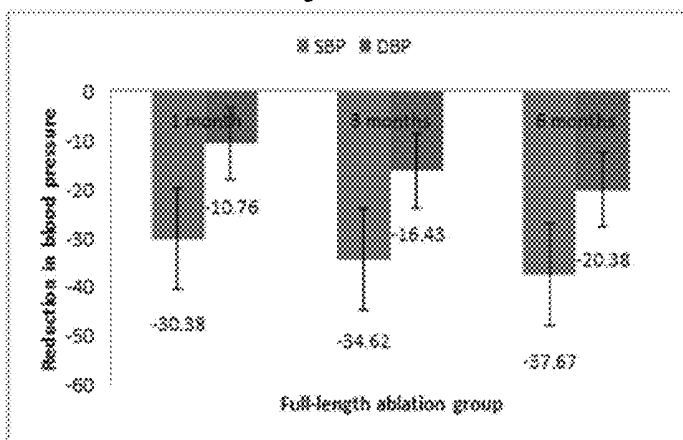

Figure 18B

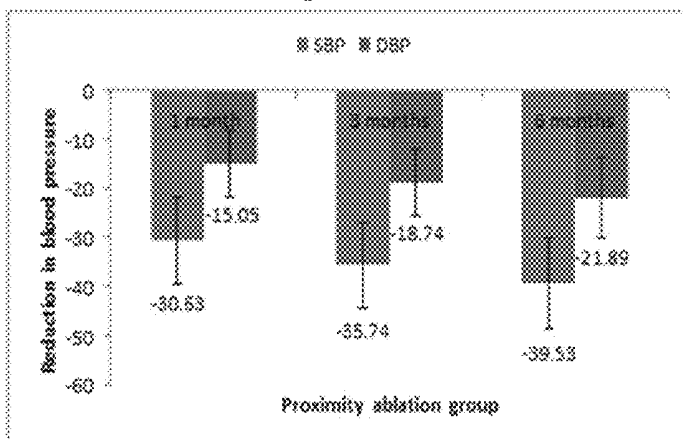

Figure 19A

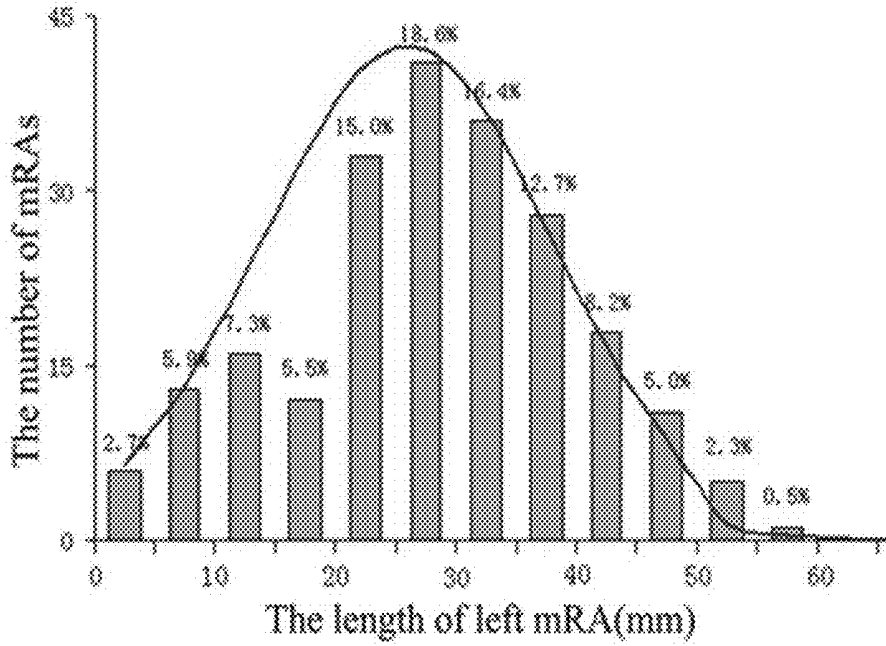

Figure 19B

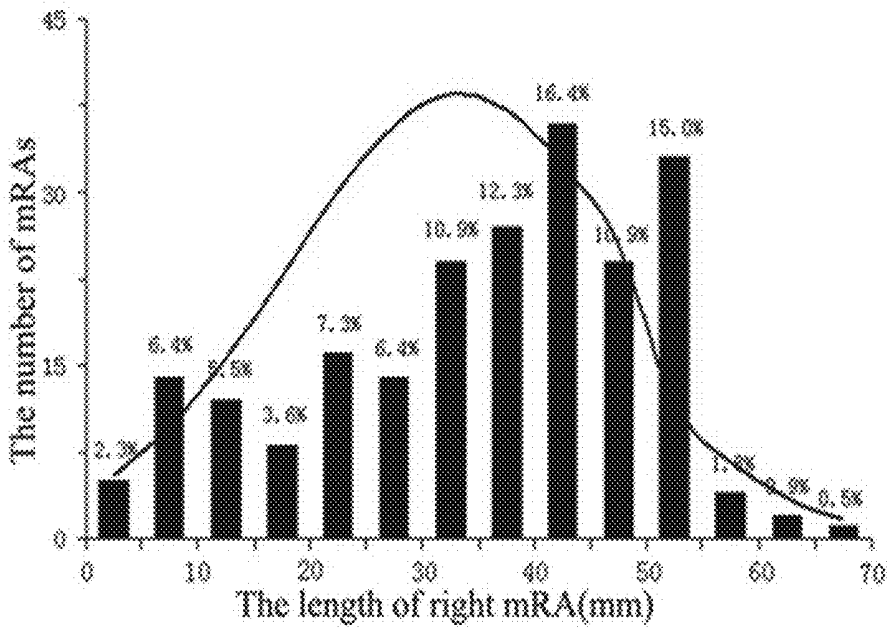

Figure 20A

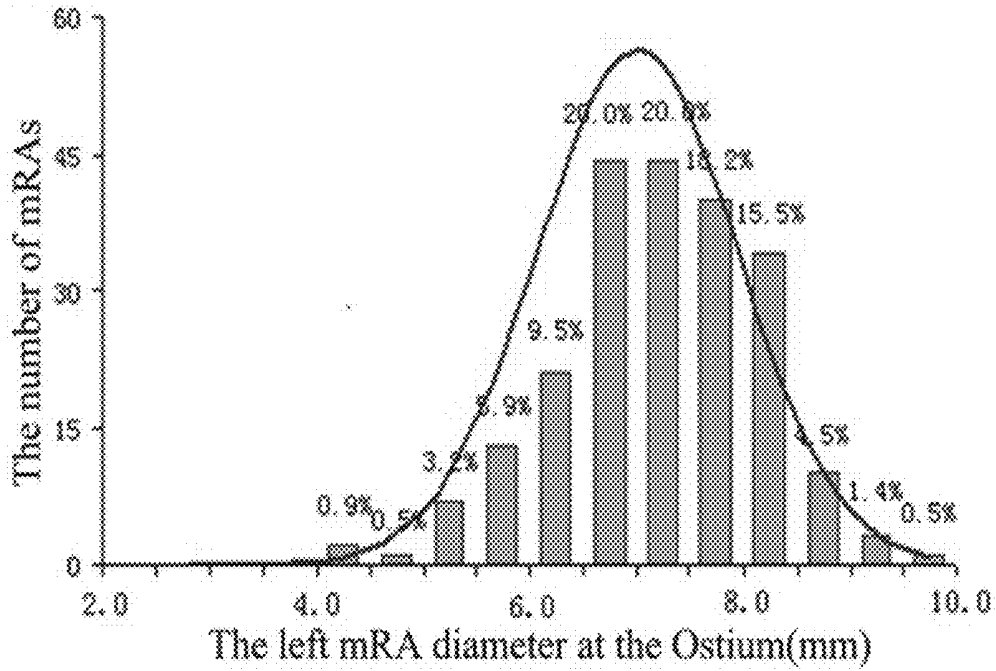

Figure 20B

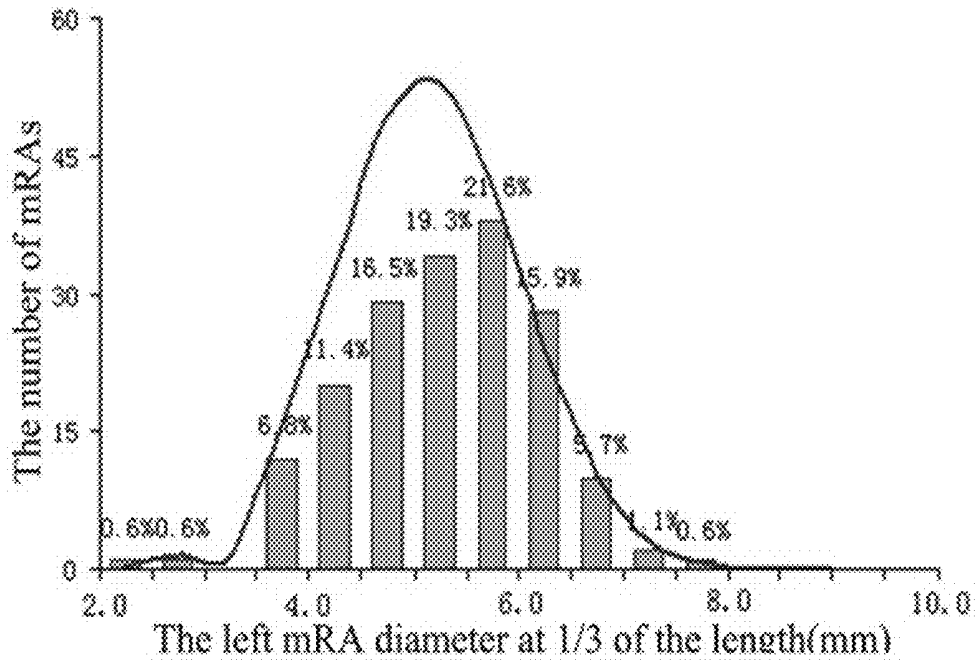

Figure 20C

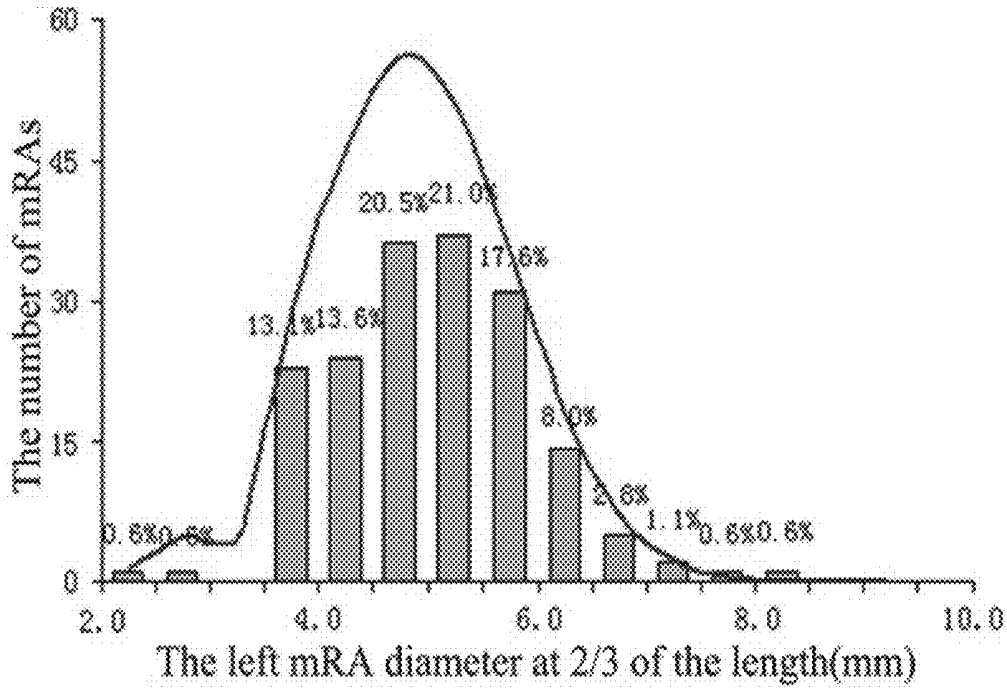

Figure 20D

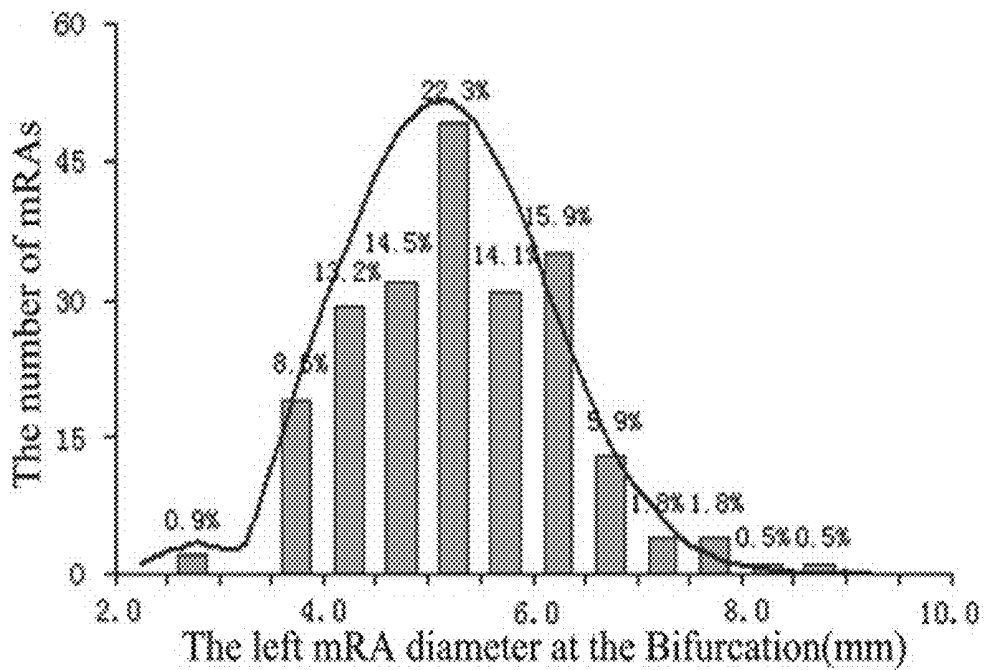

Figure 20E

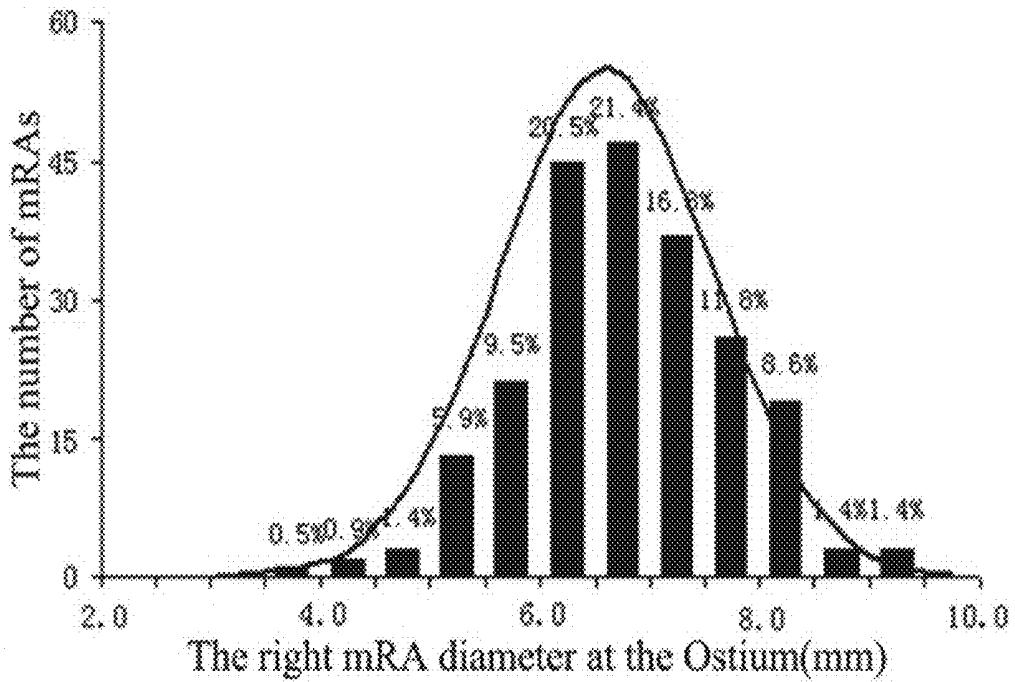

Figure 20F

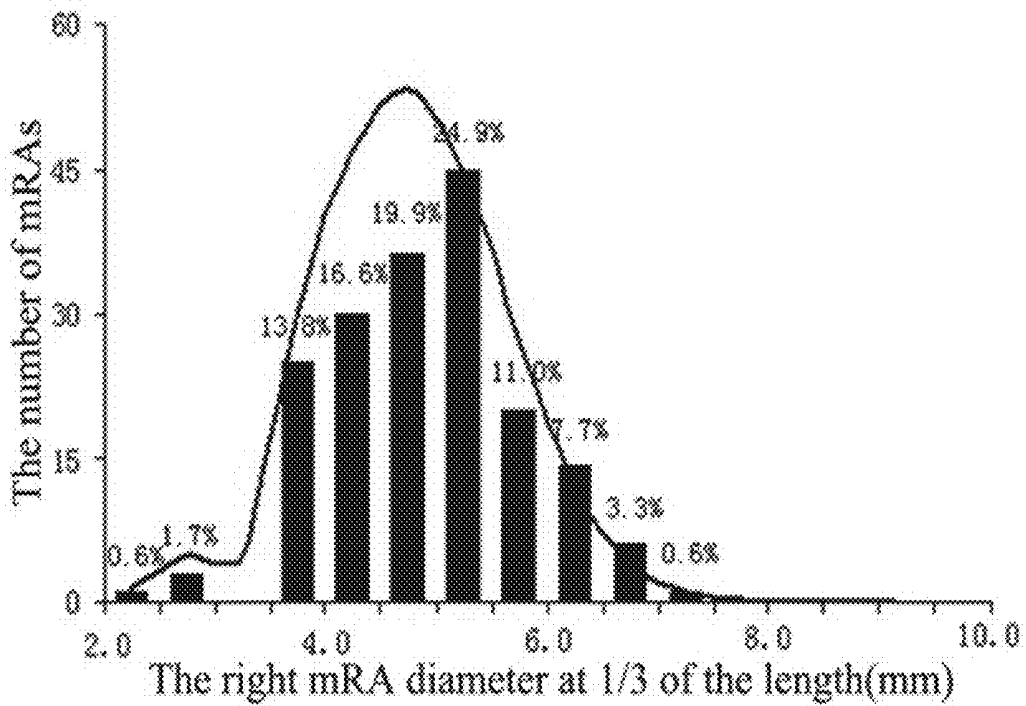

Figure 20G

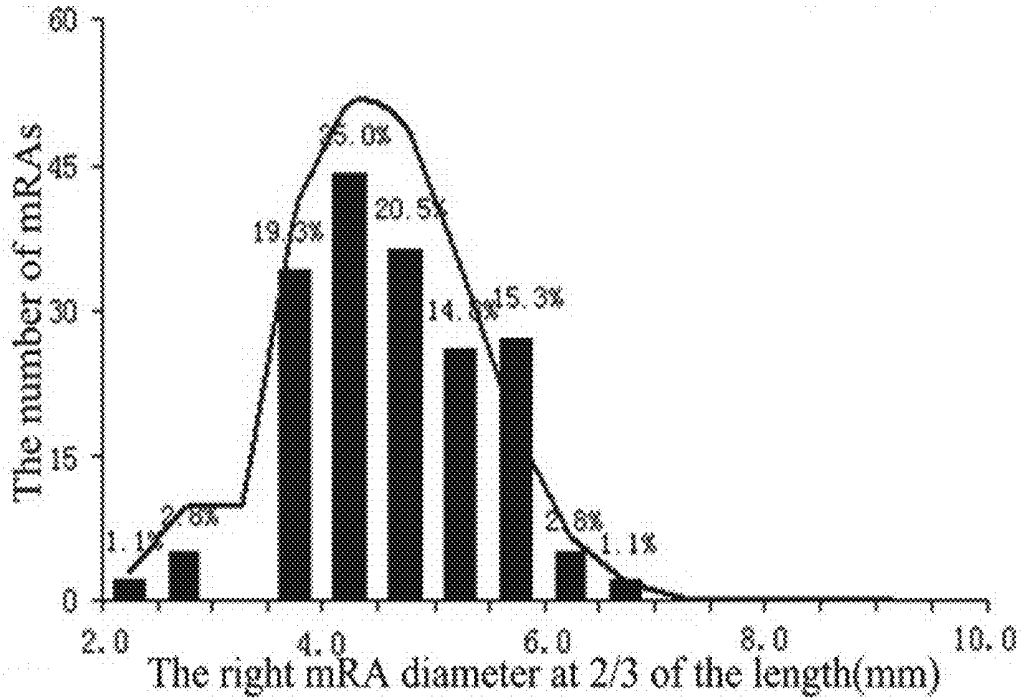

Figure 20H

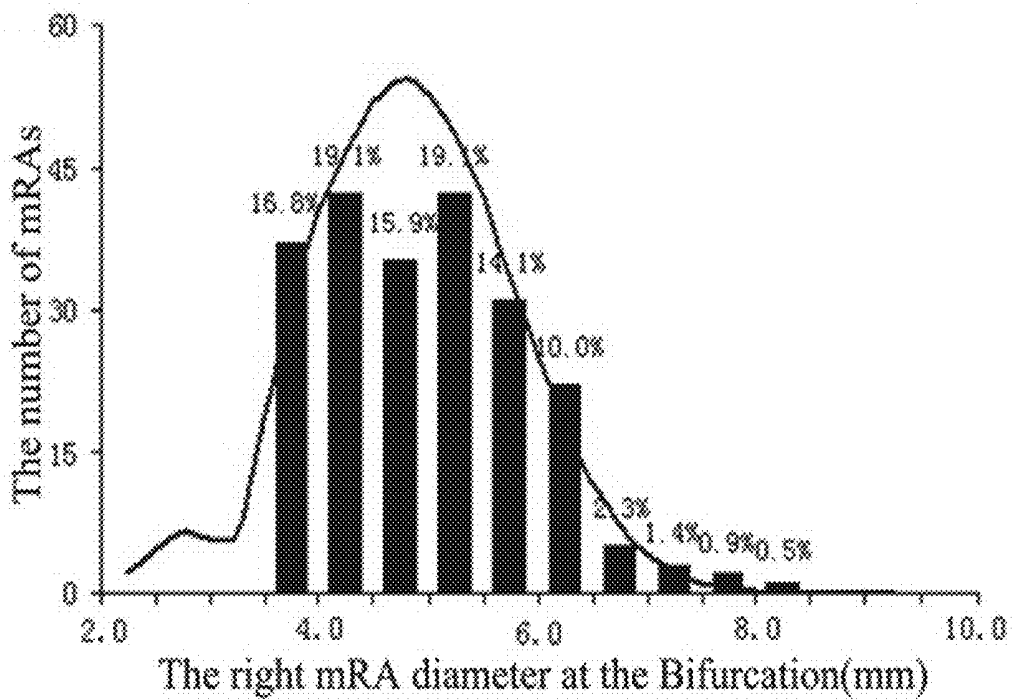

Figure 21A

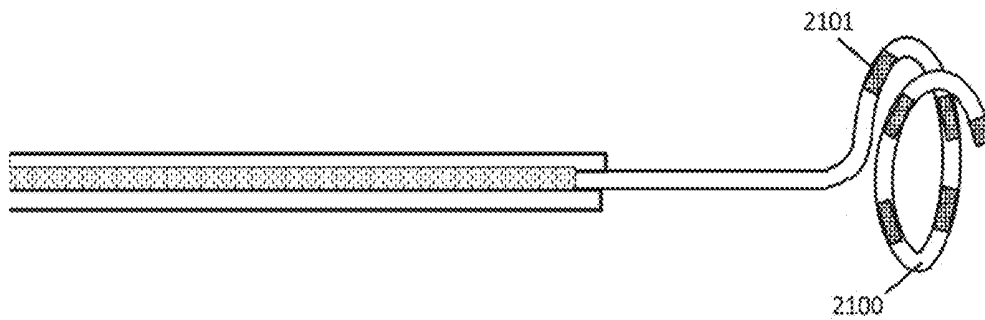

Figure 21B

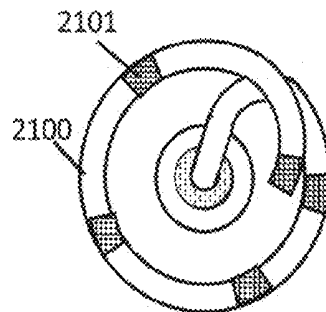

Figure 21C

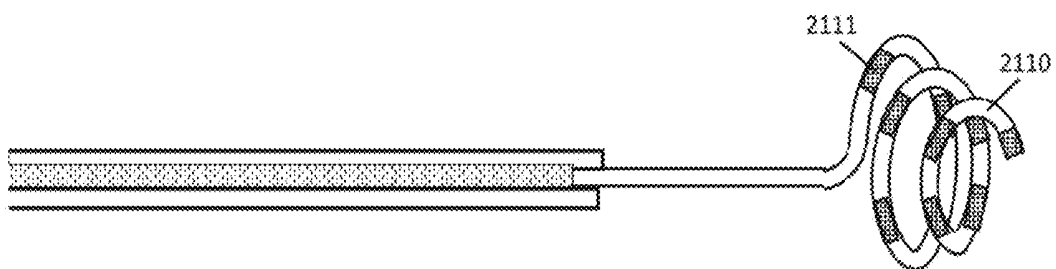

Figure 21D

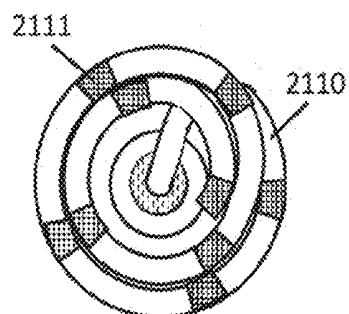

Figure 22A

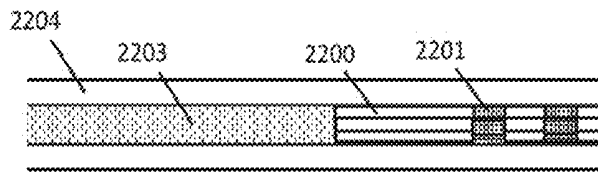

Figure 22B

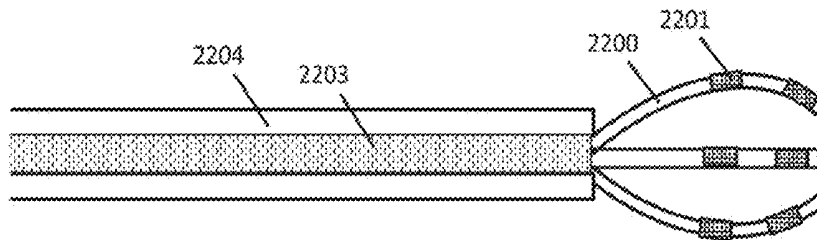

Figure 22C

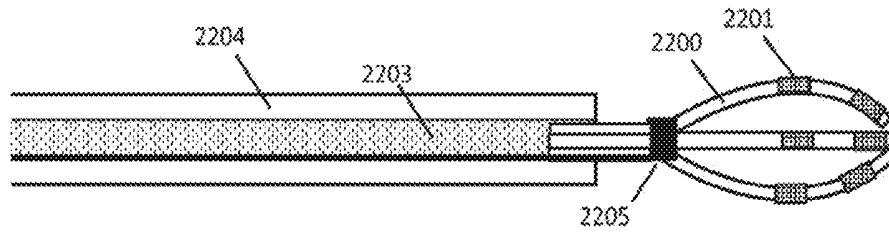

Figure 23A

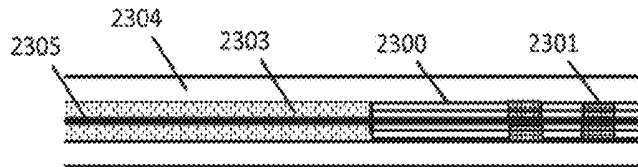

Figure 23B

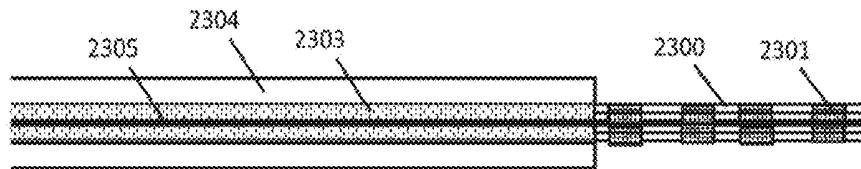

Figure 23C

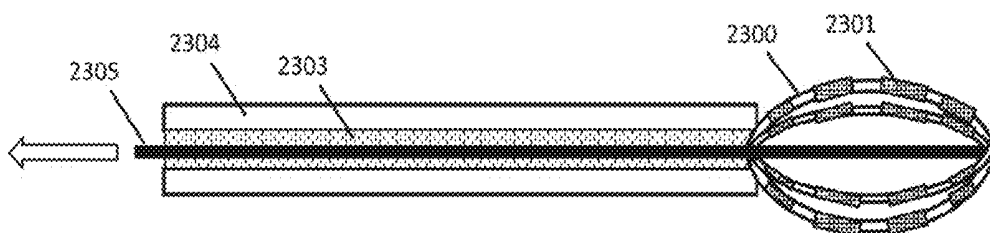

Figure 24

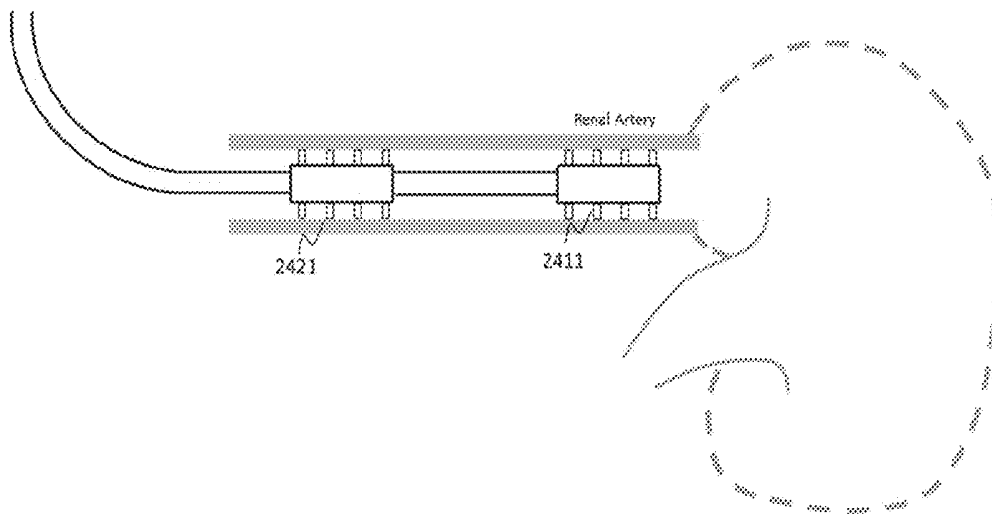

Figure 25

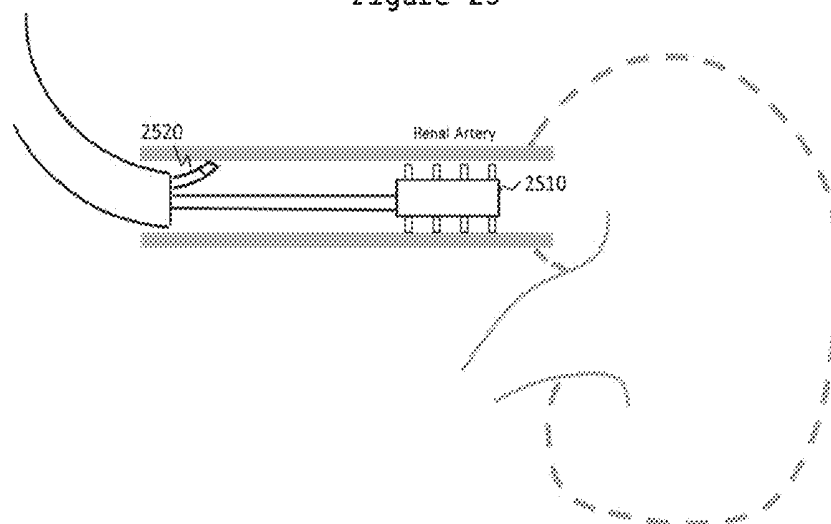
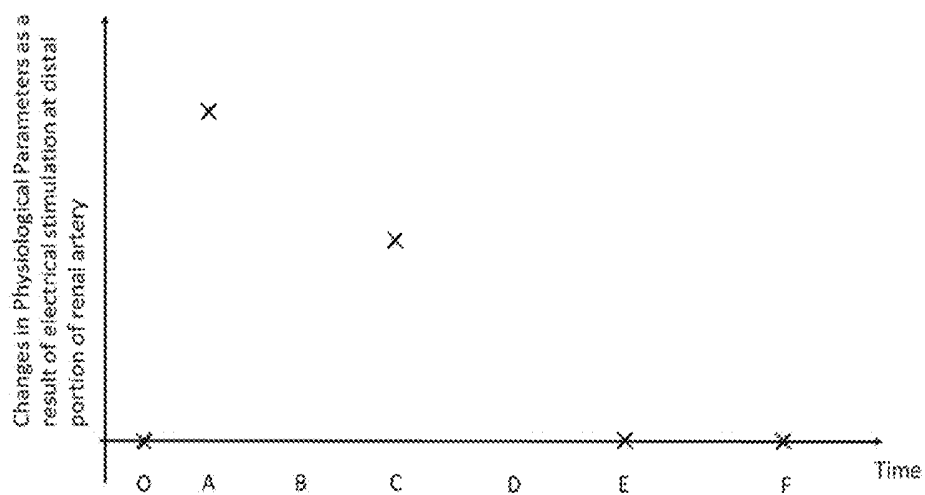

Figure 26



**SYSTEM AND METHOD FOR MAPPING
THE FUNCTIONAL NERVES INNERVATING
THE WALL OF ARTERIES, 3-D MAPPING
AND CATHETERS FOR SAME**

[0001] Throughout this application, various publications are referenced. Disclosures of these publications in their entireties are hereby incorporated by reference into this application in order to more fully describe the state of the art to which this invention pertains.

FIELD OF THE INVENTION

[0002] This invention relates to a system and method for accurate and precise location and identification of areas innervated with sympathetic and parasympathetic related nerves on an arterial wall during and after an energy delivery process. This invention also relates to catheter systems specifically designed for use in renal nerve mapping and ablation.

BACKGROUND OF THE INVENTION

[0003] Congestive heart failure, hypertension, diabetes, and chronic renal failure have many different initial causes; however, all follow a common pathway in their progression to end-stage diseases. The common pathway is renal sympathetic nerve hyperactivity. Renal sympathetic nerves serve as the signal input pathway to higher sympathetic centers located in the spinal cord and brain via afferent renal nerve activity, increasing systemic sympathetic tone; meanwhile, through efferent activity, renal nerves and arteries participate in sympathetic hyperactivity in response to signals from the brain, further increasing systemic sympathetic tone (Dibona and Kopp, 1977). Sympathetic activation can initially be beneficial but eventually becomes maladaptive. In a state of sympathetic hyperactivity, a number of pathological events take place: abnormalities of hormonal secretion such as increased catecholamine, renin and angiotensin II levels, increased blood pressure due to peripheral vascular constriction and/or water and sodium retention, renal failure due to impaired glomerular filtration and nephron loss, cardiac dysfunction and heart failure due to left ventricular hypertrophy and myocyte loss, stroke, and even diabetes. Therefore, modulation (reduction/removal) of this increased sympathetic activity can slow or prevent the progression of these diseases. Recently, renal nerve denervation using high radio frequencies has become a recognized method to treat drug resistant hypertension (Esler et al., 2010 and Krum et al., 2009) and glucose metabolism abnormality (Mahfoud, 2011). However, certain methodologies by which renal nerve ablation or denervations are performed are either primitive, or are conducted in a manner whereby the medical professional operates with undue uncertainty respecting the location of the renal nerves critical in the disease pathway. The present invention seeks to rectify certain of these problems.

Renal Sympathetic Nerve Hyperactivity and Hypertension

[0004] Renal sympathetic nerve hyperactivity's contribution to the development and perpetuation of hypertension has been systematically investigated. This connection has been explored due in large part to the fact that, despite the availability of various pharmaceutical products and combination pharmaceutical products, and resources to assist

patients' lifestyle changes, the rate of treatment of hypertension has remained surprisingly low. In particular, approximately 1/3 of hypertensive patients are not fully responsive to even optimized drug therapy and the measured blood pressure range amongst this cohort remains abnormal. This manifestation is called drug resistant hypertension. In approximately half of hypertensive patients, blood pressure remains higher than accepted treatment target levels. Amongst these patients with "essential" hypertension (i.e. persistent and pathological high blood pressure for which no specific cause can be found), it has been suggested that underlying pathophysiologies which are non-responsive to current treatment regimens exist. Further, it has been noted in such patients that efferent sympathetic renal nerve outflow stimulates renin release, increases tubular sodium reabsorption, and reduces renal blood flow, while afferent nerve signals from the kidney modulate central sympathetic outflow and thereby contribute to regulation of sodium and water metabolism, vascular tone/resistance and blood pressure.

[0005] Various data have confirmed the positive effects of renal nerve blocking on decreasing hypertension; data have further confirmed the connection between increased sympathetic nervous system activity and hypertension. In particular, studies have shown renal dysfunction as a mechanism of increased sympathetic nervous system activity leading to hypertension (Campese, 2002; Ye, 2002), that blocking renal nerve activity controls hypertension in animals with chronic renal insufficiency (Campese, 1995), and that surgical renal denervation performed to eliminate intractable pain in patients with polycystic kidney disease also eliminates hypertension (Valente 2001). Additional studies have identified increased noradrenaline spillover into the renal vein as the culprit in essential hypertension (Esler et al., 1990), and have shown that denervation by nephrectomy eliminates hypertension in humans on dialysis with severe hypertension refractory to multi-drug therapy (Converse 1992). Renal denervation has also been shown to delay or prevent the development of many experimental forms of hypertension in animals (e.g. spontaneously hypertensive rats (SHR), stroke prone SHR, New Zealand SHR, borderline hypertensive rats (BHR), Goldblatt 1K, 1C (rat), Goldblatt 2K, 2C (rat), aortic coarctation (dogs), aortic nerve transection (rat), DOCA-NaCl (rat, pig), Angiotensin II (rat, rabbit), fat feeding—obesity (dog), renal wrap (rat)) (DiBona and Kopp, 1997).

[0006] Certain previous efforts at decreasing refractory hypertension focused on a therapeutic drug approach, and in particular, the local administration of nerve blocking agents, such as local anesthetics, ketamine, tricyclic antidepressants, or neurotoxins, at the site of the nerve(s).

[0007] Studies performed in canines demonstrated proof-of-concept with regard to such a therapeutic drug approach. In one study, a total of eleven (11) dogs that had micro-embolization performed to induce acute heart failure were utilized to gather data; eight (8) dogs were treated with a renal nerve block created by injecting 10 ml of bupivacaine (Marcaine®) inside the Gerota's fascia, while three (3) served as controls. Urine output, as measured every fifteen (15) minutes, significantly increased in the bupivacaine-treated animals as compared with controls, and both natriuresis and diuresis were observed, confirming the physiologic basis for an antihypertensive effect. The same results were found in six (6) other dogs with micro-embolization resulting in chronic heart failure (Vigilance 2005).

Renal Sympathetic Nerve Hyperactivity, Insulin Sensitivity and Glucose Metabolism

[0008] Renal nerve hyperactivity is also posited to play a role in insulin sensitivity and glucose metabolism. Specifically, an increase in noradrenaline release accompanying renal nerve hyperactivity results in reduced blood flow, which in turn is associated with reduced glucose uptake. This indicates an impaired ability of cells to transport glucose across their membranes. Renal nerve hyperactivity is related to a neurally mediated reduction in the number of open capillaries, so that there is an increased distance that insulin must travel to reach the cell membrane from the intravascular compartment. Insulin-mediated increases in muscle perfusion are reduced by approximately 30% in insulin-resistant states. Consequently there is a direct relationship between muscle sympathetic nerve activity and insulin resistance, and an inverse relationship between insulin resistance and the number of open capillaries. (Mahfoud, et al., 2011). Renal sympathetic nerve hyperactivity is thus associated with certain aspects of diabetes mellitus and/or metabolic syndrome; sympathetic hyperactivity induces insulin resistance and hyperinsulinemia, which in turn produces additional sympathetic activation. Studies have been performed evaluating the effects of renal denervation on diabetic criteria.

[0009] A study by Mahfoud et al. (2011) tested the effect of renal denervation on patients who had type 2 diabetes mellitus, as well as high blood pressure of ≥ 160 mm Hg (or ≥ 150 mm Hg for patients with type 2 diabetes mellitus) despite being treated with at least 3 anti-hypertensive drugs (including 1 diuretic). At baseline and at follow-up visits taking place at one (1) and three (3) months after the procedure, blood chemistry, and fasting glucose, insulin, C peptide, and HbA1c were measured, while an oral glucose tolerance test (OGTT) was performed at baseline and after 3 months. Plasma glucose concentration was assessed with the glucose-oxidase method, while plasma insulin and C-peptide concentrations were measured by a chemiluminescent assay. Three months after denervation, diabetic indicators had substantially improved. At baseline, 13 patients in the treatment group had insulin levels ≥ 20 μ U/mL. Treatment decreased this number by 77% (n=10), with no changes in the control group. Insulin sensitivity also increased significantly after renal denervation. In 34 patients (test group, n=25; control group, n=9), the OGTT at baseline revealed 8 patients with impaired fasting glycemia, 18 patients with impaired glucose tolerance, and 8 patients with diabetes mellitus. After the procedure, 7 of 25 patients showed improvement in OGTT. The number of patients diagnosed with diabetes mellitus on the basis of OGTT was reduced by 12% (n=3); and the number of patients with normal glucose tolerance increased by 16% (n=4). Patients in the control group had no significant changes in glucose or insulin metabolism during follow-up.

[0010] The Mahfoud et al. study thus conclusively demonstrated that the renal sympathetic nervous system is an important regulator of insulin resistance and shows that renal nerve ablation substantially improves insulin sensitivity and glucose metabolism.

Renal Nerve Ablation Test Studies

[0011] During 1950s, surgical sympathectomy was utilized in humans as a treatment for severe hypertension

before the availability of antihypertensive medicine (Smithwick and Thompson, 1953). However, such surgical renal denervation was extremely invasive and involved a major surgical procedure; therefore, it had great limitations in clinical practice (DiBona, 2003).

[0012] Recently, endovascular catheter technologies have been preferably utilized to create selective denervation in the human kidney. The renal nerves primarily lay outside the vessel tunica media, within the renal artery adventitial space. Consequently, radiofrequency energy, laser energy, high intensive focused ultrasound and alcohol can be delivered to renal artery walls, and cryoablative techniques likewise utilized on renal artery walls, via the renal artery lumen, to ablate sympathetic renal nerves.

[0013] The first human study of renal nerve ablation by catheter methodologies took place on hypertensive patient test subjects in 2009. Patient test subjects were enrolled whose standing blood pressure (SBP) was more than or equal to 160 mmHg despite the patient being on more than three anti-hypertensive medications (including diuretics), or who had a confirmed intolerance to anti-hypertensive medications (Krum et al., 2009). In this study of forty-five (45) patients overall baseline patient blood pressure consisted of (mmHg) of $177/101 \pm 20/15$. Among enrolled patients, 89% of patients responded to renal denervation therapy and observed a reduction in blood pressure.

[0014] In order to assess whether renal denervation was effectively performed, after renal nerve ablation, renal noradrenaline spillover was measured to determine the success of the sympathetic denervation. Blood pressure was measured at baseline, and at 1 month, 3 months, 6 months, 9 months, and 12 months after the procedure. At each time point, decreases in both systolic and diastolic pressure were registered, with decreases continuing with the passage of time. Post-procedure, an overall decrease in total body noradrenaline spillover of 28% (p=0.043) was shown amongst the 45 test subjects, of which approximately one third was attributable to the renal sympathetic denervation. Treatment was delivered without complication in 43/45 patients, with no chronic vascular complications.

Current Protocols in Renal Denervation

[0015] After the Krum et al. study, there have been established certain accepted methodologies for performing renal nerve ablation through catheter means, though said methodologies comprise some variation. Typically, renal nerve ablation comprises catheter-based methods in which a patient is administered four (4) to six (6) two-minute radio frequency (RF) treatments per renal artery, with the radio frequency being generated by a radio frequency (RF) generator, which is automated, low-power, and has built-in safety algorithms. The radio frequencies, usually of 5-8 watts, are administered by catheter in the renal artery through movement of the catheter distal to the aorta to proximal to the aorta with application of the radio frequencies in spaced increments of 5 mm or more.

[0016] In the aforementioned Mahfoud et al. diabetes study, the following specific ablation protocol was followed: a treatment catheter was introduced into each renal artery by use of a renal double curve or left internal mammary artery guiding catheter; radiofrequency ablations lasting up to 2 minutes each were applied with low power of 8 watts to obtain up to 6 ablations separated both longitudinally and rotationally within each renal artery. Treatments were deliv-

ered from the first distal main renal artery bifurcation to the ostium. Catheter tip impedance and temperature were constantly monitored, and radiofrequency energy delivery was regulated according to a predetermined algorithm.

[0017] Endovascular catheter procedures such as those enumerated above are intended to preserve blood flow and minimize endothelial injury, while focal ablations spaced along the renal vessel allow for rapid healing. The resultant nerve ablation simultaneously diminishes the renal contribution to systemic sympathetic activation and the efferent effects of sympathetic activation of the kidney while offering a clinically durable result.

[0018] Functionally, the optimized goal of ablation of the renal arteries is to selectively disable the renal sympathetic (both afferent and efferent) nerves without impairing sympathetic signaling to other organs, and to precisely deliver energies to the locations in which renal sympathetic nerves are distributed in order to denervate the nerves. At present, renal nerve ablation is done in a “blind” fashion—that is, before the ablation radiofrequency is delivered, the physician who performs the procedure does not know where the renal sympathetic nerves are distributed so that the whole length of renal artery is ablated; furthermore, whether renal nerves have really been ablated or not can only be confirmed by measuring a secondary effect—i.e. norepinephrine spill-over, after completion of the procedure. At present, approximately 89% of patients respond to renal denervation treatment (Krum et al., 2009 and Esler et al. 2010). However, these data were determined by measurements of patient’s blood pressure to confirm the efficacy of renal denervation at least one month after the procedure. In some cases, treatment failures may be due to regeneration of renal nerves (Esler et al., *Lancet* 2010, p. 1908), while in others, treatment failures may be due to failure to correctly target and sufficiently complete ablation of the renal nerves. Therefore, methods to precisely detect where renal nerve distribution occurs along the renal arteries, so that ablation targets can be provided to physicians, and to monitor clinically relevant indices (such as blood pressure, heart rate and muscle sympathetic nerve activity) to assess whether efficient ablations are delivered, are urgently needed. As above discussed, renal afferent and efferent nerve system serves as a common pathway for sympathetic hyperactivity, therefore stimulation of renal nerve can cause increases in blood pressure and changes in heart rate. Changes in heart rate can be either increased due to direct stimulation of sympathetic nerves, or decreased blood pressure due to an indirect reflex regulation via baroreflex.

[0019] An improved methodology would involve a renal nerve mapping approach by which individual segments of the renal artery are stimulated by a low power electrical current while blood pressure, heart rate and muscle sympathetic nerve activity were measured. If measurable changes in blood pressure, heart rate and muscle sympathetic nerve activity are detected, such as increases in blood pressure or changes in heart rate or decreases in muscle sympathetic nerve activity, there is a reasonable expectation that ablation at that site should be performed so as to destroy nerve fibers in more precise way, and consequently, improve the clinical measures desired. These improved renal nerve mapping and catheterization technologies would seek to minimize unnecessary ablation in the types of denervation procedures described, guide operators to perform renal ablation proce-

dures, and to optimize clinical outcomes of renal nerve ablation for treatment of hypertension, heart failure, renal failure and diabetes.

Anatomical Mapping and Targeting in Renal Nerve Ablation

[0020] Anatomically, the nerves carrying fibers running to or from the kidney are derived from the celiac plexus (a/k/a the solar plexus) and its subdivisions, lumbar splanchnic nerves, and the intermesenteric plexus (DiBona and Kopp, 1997, p. 79). The celiac plexus consists of the suprarenal ganglion (i.e. the aorticorenal ganglion), the celiac ganglion, and the major splanchnic nerves. The celiac ganglion receives contributions from the thoracic sympathetic trunk (thoracic splanchnic nerves), and the vagus nerves (DiBona and Kopp, 1997, p. 79).

[0021] The suprarenal ganglion gives off many branches toward the adrenal gland, some of which course along the adrenal artery to the perivascular neural bundles around the renal artery entering the renal hilus; other branches enter the kidney outside the renal hilar region. The major splanchnic nerve en route to the celiac ganglion gives off branches to the kidney at a point beyond the suprarenal ganglion. The celiac ganglion gives off branches to the kidney that run in the perivascular neural bundles around the renal artery entering the renal hilus (DiBona and Kopp, 1997, p. 79).

[0022] The lumbar and thoracic splanchnic nerves are derived from the thoracic and lumbar paravertebral sympathetic trunk, respectively. They provide renal innervation via branches that go to the celiac ganglion but also via branches that go to the perivascular neural bundles around the renal artery entering the renal hilus (DiBona and Kopp, 1997, p. 79).

[0023] The intermesenteric plexus, containing the superior mesenteric ganglion, receives contributions from the lumbar splanchnic nerves and gives off branches that often accompany the ovarian or testicular artery before reaching the kidney (DiBona and Kopp, 1997, p. 79). The renal nerves enter the hilus of the kidney in association with the renal artery and vein (DiBona and Kopp, 1997, p. 81). They are subsequently distributed along the renal arterial vascular segments in the renal cortex and outer medulla, including the interlobar, arcuate, and interlobular arteries and the afferent and efferent glomerular arterioles (DiBona and Kopp, 1997, p. 81).

[0024] While the renal nerve architecture is of paramount consideration before ablation can take place, individual renal architecture must be carefully considered before catheterization for denervation can be contemplated. As noted with respect to the Krum et al./Esler et al. studies, eligibility for catheterization was determined in part by an assessment of renal artery anatomy, renal artery stenosis, prior renal stenting or angioplasty, and dual renal arteries. Not only is aberrant or unusual renal architecture an impediment to catheterization in and of itself, but normal variation in renal architecture may prove challenging, especially when an off-label catheter system (i.e. a catheter not specifically designed for renal artery ablation per se) is used. The risks of renal catheterization with sub-optimal catheter systems may include the rupture of renal arteries due to coarse or jagged manipulation of such catheter tips through delicate tissue, rupture of and/or damage to the artery wall or renal artery endothelium due to excessive ablation energy applied, and dissection of the artery. Therefore, catheter systems specially designed for renal architecture and common aber-

rations in renal architecture are desirable, in order that a large spectrum of the eligible refractory patient population be treated.

Catheter Systems

[0025] Certain catheter systems designed for coronary artery systems are similar to those which may be used in renal nerve ablation; in particular, ablative catheter systems designed for coronary artery use which are tailored to remedy tachycardia may be used for renal nerve ablation procedures. As such, these systems typically contain electrodes which are designed to assess the pre-existing electric current in the cardiac tissue through which the catheter electrodes are being passed. In contrast, ideal catheter systems for renal denervation would optimally be engineered with dual functions: to map renal nerve distribution and stimulate renal nerve activity by providing electrical stimulation so that a physician operator may assess in real-time patient physiological changes occurring as a result of said electrical stimulation and renal denervation. However, such catheters have not previously been developed.

[0026] Known catheter systems often possess multiple functionalities for cardiac uses. Certain notable catheter systems on the market include the following:

A) Medtronic Achieve™ Electrophysiology Mapping Catheter

[0027] This catheter is normally used for assessment of pulmonary vein isolation when treating paroxysmal atrial fibrillation. It is used in conjunction with Medtronic's Arctic Front cryoablation system. The Achieve™ Mapping Catheter has a distal mapping section with a circular loop which is available in two loop diameters (15 mm and 20 mm). It is deployed through the Arctic Front guidewire lumen, allowing for a single transeptal puncture. The catheter features eight evenly spaced electrodes on a loop, enabling physicians to map electrical conduction between the left atrium and pulmonary veins. Additionally, the catheter allows for assessment of pulmonary vein potential both before and after cryoablation and also helps physicians assess time-to-effect during cryoablation. Its specifications are as follows:

- [0028]** i. 3.3 Fr, 1.1 mm (0.043") catheter shaft size
- [0029]** ii. 165 cm in total length; 146 cm in usable length
- [0030]** iii. Two loop sizes: 15 mm and 20 mm
- [0031]** iv. Two electrode spacings: 4 mm and 6 mm
- [0032]** v. Eight 1 mm electrodes
- [0033]** vi. Catheter is compatible with minimum ID of 3.8 Fr, 1.3 mm (0.049")

B) Northwestern University/University of Illinois at Urbana-Champaign all-in-One Cardiac EP Mapping and Ablation Catheter

[0034] This catheter is a combination catheter utilized to perform cardiac electrophysiological mapping and ablations. The balloon catheter includes temperature, pressure, and EKG sensors, and an LED that can ablate cardiac tissue. The catheter is based on a "pop-out" design of interconnects, and the concept of stretchable electronics. In this design, all necessary medical devices are imprinted on a section of a standard endocardial balloon catheter (a thin, flexible tube) where the wall is thinner than the rest; this section is slightly recessed from the rest of the catheter's surface. In this recessed section, the sensitive devices and actuators are protected during the catheter's trip through the body to the

heart. Once the catheter reaches the heart, the catheter is inflated, and the thin section expands significantly so that the electronics are exposed and in contact with the heart.

[0035] When the catheter is in place, the individual devices can perform their specific tasks as needed. The pressure sensor determines the pressure on the heart; the EKG sensor monitors the heart's condition during the procedure; the LED sheds light for imaging and also provides the energy for ablation therapy to ablate tissue (in this case, typically tachycardia-inducing tissue); and the temperature sensor controls the temperature so as not to damage other healthy tissue. The entire system is designed to operate reliably without any changes in properties as the balloon inflates and deflates.

[0036] The system is designed to deliver critical high-quality information, such as temperature, mechanical force, blood flow and electrograms to the surgical team in real time.

C) Medtronic Arctic Front®

[0037] The Arctic Front® is an FDA-approved cryoballoon ablation system. The balloon is delivered via the accompanying FlexCath® Steerable Sheath; liquid coolant is pumped in using the CryoConsole control unit. The unit is normally used to treat paroxysmal atrial fibrillation. Its specifications are as follows:

- [0038]** i. Two balloon diameters: 23 mm and 28 mm
- [0039]** ii. Double balloon safety system
- [0040]** iii. Bi-directional deflection (45 degrees maximum)
- [0041]** iv. Compatible with 12F FlexCath® Steerable Sheath
- [0042]** v. 102 cm working length

D) Diagnostic Products Lasso Circular Mapping Catheter

[0043] The LASSO 2515 Variable Circular Mapping Catheter features a variable loop which adjusts to fit veins sized between 25 and 15 mm.

E) Ardian Symplicity® Catheter System

[0044] The current catheter system utilized for renal ablation, comprising both an ablation catheter and radio frequency generator, i.e. the Symplicity® Catheter System, is specially designed by Ardian Inc. (Mountain View, Calif., USA). However, the Symplicity® catheter does not possess mapping functions and ablation is its only function; and secondly, such catheter systems (as well as angioplasty and distal protection devices for angioplasty) were designed for coronary and carotid artery systems—hence, these systems would be used "off-label" for renal nerve ablation and denervation to treat hypertension, heart failure, renal failure and diabetes.

[0045] The fact that some cases of hypertension are resistant to treatment by pure pharmacological means has reignited the use of invasive techniques in treating these cases. Historically, surgical renal denervation was the prominent treatment for severe cases of hypertension prior to the introduction of orally administered anti-hypertensive drugs (Smithwick and Thompson, 1953). This type of conventional surgery was, however, extremely invasive and involved a major surgical procedure which greatly limits its practicality (DiBona, 2003). At least two clinical studies have, to a certain extent, provided support to the use of

minimally invasive catheter-based radiofrequency (RF) renal nerve ablation in the treatment of resistant hypertension (Krum et al., 2009; Esler et al., 2009). Patients with hypertension resistant to the available anti-hypertensive drugs were selected for these studies and this interventional procedure demonstrated a 89% clinical success rate in lowering their blood pressure in a small and very selective patient population.

[0046] While there is growing interest in using such minimal invasive interventional techniques for treatment of hypertension, all systems on the market, including the Ardian Symplicity® Catheter System, are not optimally designed for this purpose. There are apparent shortcomings, even in the Ardian Symplicity® Catheter System, that limit the certainty of the interventional outcome.

[0047] An important aspect not considered in the current interventional systems and techniques, is the precision and accuracy in locating and delivering an effective dose of energy to a suitable ablation spot in the arterial wall. The current commonly accepted procedures for performing renal nerve ablation via catheters typically consists the steps of administering to the arterial wall 4 to 6 ablations, each made by 2 minutes of RF energies and spaced both longitudinally and rotationally along the inner wall of each renal artery. The ablations had to be delivered “blindly” in this helical manner because the exact location of the nerves innervating the renal artery with respect to the ablation catheter is unknown before and during the delivery of the ablation energy. An inaccurately directed dose of energy not only causes unnecessary damage to healthy tissues and non-sympathetic nerves but more importantly could not provide the promised solution for hypertension which the interventional procedure was intended for. In fact, in certain clinical settings other than the two published studies, the responder rate of the current “blind” type of interventional procedure could go as low as 50% (Medical devices: pg 1-2, Feb. 22, 2012).

[0048] Theoretically, precise nerve ablation in the wall of an artery could be achieved by mapping the location of the nerves innervating the arterial wall prior to delivery of the dose of energy. By monitoring physiological parameters associated with the autonomic nervous systems such as the blood pressure, heart rate and muscle activity while a stimulus is delivered to a selected location on the arterial wall, the presence of autonomic nerves in the immediate vicinity of this location will be reflected from the changes in the monitored physiological parameters (Wang, US 2011/0306851 A1).

[0049] Further, the sympathetic and parasympathetic nerves of the autonomic nervous system often exert opposite effects in the human body including their control on blood pressure and heart rate. While ablation of the sympathetic nerves innervating the arterial walls will relieve hypertension, there is an equally possible chance that other tissues such as parasympathetic nerves are ablated in the “blind” type of interventional procedure. The result for decreasing or removal of nerve activity blindly may worsen the hypertension as could be inferred from several animal studies (Ueda et al., 1967; Beacham and Kunze, 1969; Aars and Akre, 1970; Ma and Ho, 1990; Lu et al. 1995).

[0050] The cause of failure in the current treatment was attributed to regeneration of the nerves after the ablation (Esler et al., 2010) and may also be related to both the inability to deliver the dose of energy to the targeted nerve and an insufficient dose of energy delivered for effective

ablation. At present, the success of renal denervation is only assessed by the measurement of a secondary effect known as norepinephrine spillover at least days after the interventional procedure (Krum et al., 2009) and lack a method for immediate post-procedural assessment. In order to improve the success rate of the interventional procedure, it is important to not only locate suitable ablation spots on the arterial wall, but also ensure that the energy is precisely and accurately delivered to a targeted nerve during the ablation process, and confirm immediately after the ablation that the dosage of energy delivered has effectively ablated the targeted nerve.

[0051] In response to the shortcomings of the current system and methods for nerve ablation, the present invention introduces improvements by providing a system and methods for accurate and precise location of suitable ablation spots on a renal arterial wall; ensuring sufficient ablation energy is accurately directed into a targeted nerve and to conduct immediate post-procedural assessment of nerve ablation. A catheter system optimal for renal nerve mapping is also provided by this invention.

SUMMARY OF THE INVENTION

[0052] It was with the preceding needs in mind that the present invention was developed. Embodiments of the disclosure are directed to catheters, system and method for accurate and precise location of areas innervated with nerves on an arterial wall; ensuring sufficient energy is accurately directed into a targeted nerve to elicit a desired response such as stimulation and ablation; and to conduct immediate post-procedural assessment of a sufficient nerve ablation. Further, the embodiments of the disclosure are also directed to provide an interface for clear representation of the location and type of nerves that are innervating the location being probed on the arterial wall.

[0053] The present invention provides a method for identifying the presence of functional sympathetic and parasympathetic nerves innervating the arterial walls in a human body with respect to the location of a dose of energy. The method comprises one or more of the steps of preparing a baseline of one or more of physiological parameters prior to the delivery of a dose of energy to the arterial wall; delivering a dose of energy to the arterial wall; detecting the physiological changes as a result of the delivered energy; rating the change based on a set of empirically pre-determined values; and determining if the area where the energy was delivered lies in the vicinity of functioning sympathetic or parasympathetic nerves based on the ratings.

[0054] In one embodiment, said method is used for locating suitable nerve ablation sites relevant to baroreflex including both sympathetic and parasympathetic systems in arterial walls prior to a nerve ablation procedure. In certain embodiments, the nerve ablation procedure is for denervation of the renal artery. In another embodiment, the method is used for ensuring the accurate delivery of ablation energy to a targeted nerve in the arterial wall during a nerve ablation process. In a further embodiment, the method is used for immediate post-procedural assessment of the nerve ablation process to ensure that the targeted nerve has been ablated by the energy delivered in a nerve ablation procedure.

[0055] In certain embodiments, the energy is delivered to the arterial wall at dosage suitable for nerve stimulation. In other embodiments, the energy is delivered to the arterial wall at a dosage suitable for nerve ablation.

[0056] In one embodiment, the physiological parameters comprise blood pressure, heart rate, levels of biochemicals such as epinephrine, norepinephrine, renin-angiotensin II and vasopressin, cardiac electrical activity, muscle activity, skeletal nerve activity, action potential of cells or other measurable reactions as a result of these physiological changes such as pupil response, electromyogram and vascular constriction.

[0057] In some embodiments, an area on the arterial wall that, upon stimulation, causes increase in blood pressure and heart rate is considered as innervated with sympathetic nerves while, in contrary, an area on the arterial wall that, upon stimulation, causes decrease in blood pressure and heart rate is considered as innervated with parasympathetic nerves.

[0058] In an embodiment, the energy for ablation is considered to be delivered accurately to a targeted nerve innervating the arterial wall when the physiological parameters deviate significantly from the baseline during the ablation process.

[0059] In one embodiment, the nerve ablation procedure is considered to be successful when an area, confirmed to be innervated with nerves with said method before the delivery of ablation energy, no longer leads to changes in the physiological parameters such as blood pressure and heart rate when stimulation energy is delivered to this spot

[0060] The present invention also provides a system for locating and identifying nerves innervating an arterial wall. The system comprises one or more devices capable of delivering a dose of energy to an arterial wall; one or more sensors to receive signals of physiological parameters; one or more devices for analysis of signals from the sensors; and one or more indicators or panels capable of displaying the results of the analysis.

[0061] In one embodiment, the dose of energy delivered by the energy delivery device can be controlled to achieve either nerve stimulation or nerve ablation. In another embodiment, two separate devices are used to carry out nerve stimulation and nerve ablation independently.

[0062] In another embodiment, the energy delivered is one or more of electrical, mechanical, ultrasonic, radiation, optical and thermal energies.

[0063] In some embodiments, said sensors detect physiological parameters which comprise blood pressure, heart rate, levels of biochemicals such as epinephrine, norepinephrine, renin-angiotensin II and vasopressin, cardiac electrical activity, muscle activity, skeletal nerve activity, action potential of cells and other measurable reactions as a result of the above such as pupil response, electromyogram and vascular constriction. In certain embodiments, the signals corresponding to the physiological parameters are detected with commercially available technologies known in the field.

[0064] In another embodiment, the device for digital analysis of the physiological signals is a microcontroller or computer.

[0065] In one embodiment, the analyzed results are displayed using different colored indicators. An area innervated with sympathetic nerves is represented with a green indicator and an area innervated with parasympathetic nerves is represented with a red indicator. In another embodiment, the analyzed data are displayed on a digital viewing panel.

[0066] In one embodiment, the set of indicators or panels may be built into devices in the system such as the energy

delivery device. In certain embodiments, the set of indicators or panels may exist as a separate entity in the system.

[0067] The present invention also provides for specially-designed catheters with a distal end (i.e. the catheter tip) in shapes customized to renal architecture, possessing one or more electrodes to map renal nerve distribution, to perform renal ablations, to perform post-ablation assessment and to perform angiography. In certain embodiments, the electrodes of such catheters are sequentially spaced along the length of the catheter tip, where the electrode faces make contact with segmented portions of the renal artery lumen. In certain embodiments, the tip of the catheter is steerable and has a single electrode for emitting radio frequency energy. In certain embodiments, the shape of the catheter tip is a single helix wherein the coil of the helix is either round or flat in shape. In other embodiments, the catheter tip is a double helix wherein the coils of the helices are either round or flat in shape. In further embodiments, the catheter tip may comprise a balloon around which is wrapped a helical coil, wherein spaced along the length of the helical coil are electrodes; alternately, the catheter tip may comprise a balloon around which is an umbrella component encapsulating the balloon, and wherein spaced along the umbrella component are electrodes. In variations of both embodiments, the coil or umbrella component may be either round or flat in shape; consequently the electrodes spaced along the length of the coil or umbrella may be round or flat in shape, depending upon the underlying shape of the coil or umbrella.

[0068] In further embodiments, the catheter tip may comprise an umbrella shape or frame with a closed end, or umbrella with an open end.

[0069] In certain embodiments, the above catheter tips may be introduced into the arterial architecture to perform the functions of a stent.

[0070] In one embodiment, the diameter of these catheter tips may vary from 0.5 mm to 10 mm; the length of the catheter tips may vary from 20 mm to 80 mm; the diameters of coil may vary from 3.0 mm to 7.5 mm; the distances between each coil may vary from 4 mm to 6 mm; and the fully uncoiled lengths of the coils may vary from 31 mm to 471 mm.

[0071] The electrodes of the catheters may be activated independently of one another or can be activated in any combination to emit electrical stimulation or radiofrequency energy. The electrodes each have dual functions of delivering electrical stimulation or radiofrequency energy. Electrical stimulation is used to identify and map segments of renal artery lumen beneath which lie renal nerves of importance. Said identification and mapping is accomplished through the monitoring of a physiological response or responses to the applied electrical stimulation, such as changes in blood pressure response and heart rate or muscle sympathetic nerve activity (Schlaich et al., NEJM 2009), or renal norepinephrine spillover (Esler et al. 2009, and Schlaich et al., J Htn. 2009), wherein changes in physiological response indicate the presence of an underlying sympathetic nerve distribution in the vicinity of the activated electrode. In another embodiment, individual electrodes of the catheters may be activated in physician operator-selected combinations in order to assess maximal physiological response, and the consequent locations of underlying renal nerves. The electrodes of the catheters are able to emit not just electrical current of sufficient strength to stimulate renal nerve, but thermal energy such as radiofrequency energy to ablate

underlying renal nerve tissue based on renal nerve mapping results. In other embodiments, separate electrodes of the catheters can be selectively activated to emit ablative energy such as high radiofrequency energy wherein the choice of the activated electrodes is based upon the results of the mapping of the nerves. In further embodiments, based on the mapping of the renal nerves, ablative techniques using other types of ablative energy such as laser energy, high intensive focused ultrasound or cryoablative techniques can be utilized on renal artery walls to ablate the sympathetic renal nerves.

[0072] In certain embodiments, these catheters are interchangeably used with existing radiofrequency generators which are presently utilized with existing cardiac catheter systems.

[0073] In one embodiment, the aforementioned catheter systems may be utilized with any variety of acceptable catheter guidewire previously inserted into the patient's body to guide the catheter tip to the desired location. They may also be used with devices and other instruments that may be used to facilitate the passage of like devices within the cardiovascular and renal vascular systems, such as sheaths and dilators. When required, the aforementioned catheter systems may also be utilized with a puller wire to position the catheter tip.

[0074] The present invention also provides methods of using the catheters described herein to map renal nerve distribution, comprising the steps of using electrical stimulation while monitoring changes in physiological responses, such as blood pressure and heart rate, to map renal nerve distribution and identify ablation spots within renal arteries for ideal denervation of renal nerves. These methods comprise activating the independent electrodes of the described catheters to emit an electrical charge to stimulate the underlying renal nerve while monitoring physiological responses such as blood pressure and heart rate; the presence of changes in physiological response indicate the presence of an underlying sympathetic nerve in the vicinity of the activated electrode and a superior location for ablation. An agglomeration of mapping data may take the form of a clinically useful guide respecting renal nerve distribution to assist clinicians in performing ablation.

BRIEF DESCRIPTION OF THE FIGURES

[0075] FIG. 1 is a schematic of a system of the present invention for locating and identifying functional nerves innervating the wall of an artery. The system comprises device 101 for delivery of energy to the arterial wall; power source 102 for powering device 101; sensor 103 for detecting signals of physiological parameters; device 104 for analyzing the data from sensor 103; and indicator 105 to display the results from device 104.

[0076] FIG. 2 is a schematic diagram depicting the steps in an embodiment of the method to determine whether functioning sympathetic or parasympathetic nerves are in the vicinity of a dose of energy delivered to the arterial wall. The graphs illustrate possible recorded physiological signals.

[0077] FIG. 3A shows an elevational view of the distal portion (catheter tip) of a single helix ablation catheter according to one embodiment of the present invention wherein electrodes 301 are placed at 90° intervals along the helix length, wherein the helical coil 303 itself is round, and wherein "L" designates the length of the distal portion, "l"

designates the length of one turn of a single coil, "d" designates diameter of catheter tip and "D" designates diameter of the helical coil.

[0078] FIG. 3B shows the distribution of electrodes 301 in a single complete coil in the helix of the ablation catheter shown in FIG. 3A.

[0079] FIG. 3C shows an end-on view of the distal portion of a single helix ablation catheter according to the embodiment shown in FIG. 3A from the delivery direction of the lead, displaying only the first turn of the coil with electrodes 301.

[0080] FIG. 3D shows an elevational view of the distal portion of a single helix ablation catheter according to an embodiment of the present invention wherein electrodes 305 are placed at 120° intervals along the helix length, and wherein the helical coil 307 itself is round.

[0081] FIG. 3E shows the distribution of electrodes 305 in a single complete coil in the helix of the ablation catheter shown in FIG. 3D.

[0082] FIG. 3F shows an end-on view of the distal portion of a single helix ablation catheter according to the embodiment shown in FIG. 3D from the delivery direction of the lead, displaying only the first turn of the coil with electrodes 305.

[0083] FIG. 3G shows an elevational view of the distal portion of a single helix ablation catheter according to an embodiment of the present invention wherein electrodes 309 are placed at 90° intervals along the helix length, and wherein the helical coil 311 itself is flattened.

[0084] FIG. 3H shows the distribution of electrodes 309 in a single complete coil in the helix of the ablation catheter shown in FIG. 3G.

[0085] FIG. 3I shows an elevational view of the distal portion of a single helix ablation catheter according to the embodiment of the present invention wherein electrodes 313 are placed at 120° intervals along the helix length, and wherein the helical coil 315 itself is flattened.

[0086] FIG. 3J shows the distribution of electrodes 313 in a single complete coil in the helix of the ablation catheter shown in FIG. 3I.

[0087] FIG. 4A shows an elevational view of a distal portion of a double helix ablation catheter according to an embodiment of the present invention wherein electrodes 417 are placed at 90° intervals along the length of each separate helix, wherein the helical coils 419 are round, and wherein "L" designates the length of the distal portion, and "l" designates the length of one turn of each helical coil.

[0088] FIG. 4B shows an end-on view of the distal portion of a double-helix ablation catheter according to the embodiment shown in FIG. 4A from the delivery direction of the lead, displaying only the first turn of each coil with electrodes 417.

[0089] FIG. 4C shows an elevational view of a distal portion of a double helix ablation catheter according to an embodiment of the present invention wherein electrodes 421 are spaced at 120° intervals along the length of each separate helix, wherein the helical coils 423 are round, and wherein "L" designates the length of the distal portion, and "l" designates the length of one turn of each helical coil.

[0090] FIG. 4D shows an end-on view of the distal portion of a double-helix ablation catheter according to the embodiment shown in FIG. 4C from the delivery direction of the lead, displaying only the first turn of each coil with electrodes 421.

[0091] FIG. 4E shows an elevational view of the distal portion of a double helix ablation catheter according to an embodiment of the present invention wherein electrodes 425 are spaced at 90° intervals along the length of each separate helix, and wherein the helical coils 427 are flat.

[0092] FIG. 4F shows an elevational view of the distal portion of a double helix ablation catheter according to an embodiment of the present invention wherein electrodes 429 are spaced at 120° intervals along the length of each separate helix, and wherein the helical coils 431 are flat.

[0093] FIG. 5A shows an elevational view of a distal portion of a balloon ablation catheter according to an embodiment of the present invention, wherein the balloon 533 is inflated, and wherein electrodes 535 are evenly spaced at intervals along a helical coil 537 which is round in shape and wrapped around the balloon.

[0094] FIG. 5B shows an elevational view of a distal portion of a balloon ablation catheter according to an embodiment of the present invention incorporating an umbrella-like component 539 encapsulating the balloon 541, wherein the balloon is inflated, and wherein electrodes 543 are spaced at intervals along the umbrella encapsulating the balloon.

[0095] FIG. 6A shows an elevational view of a distal portion of an ablation catheter according to an embodiment of the present invention incorporating a closed-end umbrella like frame 645 wherein electrodes 647 are spaced at intervals along the umbrella like frame.

[0096] FIG. 6B shows an end-on view of the distal portion of an ablation catheter according to the embodiment like shown in FIG. 6A from the delivery direction of the lead.

[0097] FIG. 6C shows an elevational view of a distal portion of an ablation catheter according to an embodiment of the present invention incorporating an open-end umbrella like frame 649 wherein electrodes 651 are spaced at intervals along the umbrella frame.

[0098] FIG. 6D shows an end-on view of the distal portion of an ablation catheter from the delivery direction of the lead.

[0099] FIG. 7A shows an elevational view of a distal portion of an ablation catheter according to an embodiment of the present invention wherein a single electrode 755 is located at a steerable catheter tip 753.

[0100] FIG. 7B shows an end-on view of the distal portion of an ablation catheter according to the embodiment shown in FIG. 7A from the delivery direction of the lead, displaying the electrode 755.

[0101] FIG. 8 shows the experimental setup for acute pig experiments used in nerve mapping experiments.

[0102] FIG. 9A shows Maximal and Minimal Effects of Left Renal Artery Stimulation on Arterial Systolic Pressure (ASP). Shown is arterial systolic pressure (ASP, as measured in mmHg) after an electrical stimulation in the left renal artery (LRA); baseline measures, as well maximal and minimal responses after the stimulation are shown.

[0103] FIG. 9B shows Maximal and Minimal Effects of Left Renal Artery Stimulation on Arterial Diastolic Pressure (ADP). Shown is arterial diastolic pressure (ADP, as measured in mmHg) after an electrical stimulation in the left renal artery (LRA); baseline measures, as well as maximal and minimal responses after the stimulation are shown.

[0104] FIG. 9C shows Maximal and Minimal Effects of Left Renal Artery Stimulation on Mean Arterial Pressure (MAP). Shown is mean arterial pressure (MAP, as measured

in mmHg) after an electrical stimulation in the left renal artery (LRA); baseline measures, as well as maximal and minimal responses after the stimulation are shown.

[0105] FIG. 9D shows Maximal and Minimal Effects of Left Renal Artery Stimulation on Heart Rate (HR). Shown are maximal and minimal changes in heart rate after left renal artery (LRA) electrical stimulation; baseline measures, as well as maximal and minimal heart rates after the stimulation are shown.

[0106] FIG. 10A shows Maximal and Minimal Effects of Right Renal Artery Stimulation on Arterial Systolic Pressure (ASP). Shown is arterial systolic pressure (ASP, as measured in mmHg) after stimulation in the right renal artery (RRA); baseline measures, as well maximal and minimal responses after an electrical stimulation are shown.

[0107] FIG. 10B shows Maximal and Minimal Effects of Right Renal Artery Stimulation on Arterial Diastolic Pressure (ADP). Shown is arterial diastolic pressure (ADP, as measured in mmHg) after an electrical stimulation in the right renal artery (RRA); baseline measures, as well as maximal and minimal responses after the stimulation are shown.

[0108] FIG. 10C shows mean arterial pressure (MAP, as measured in mmHg) after an electrical stimulation in the right renal artery (LRA); baseline measures, as well as maximal and minimal responses after the stimulation are shown.

[0109] FIG. 10D shows Maximal and Minimal Effects of Right Renal Artery Stimulation on Heart Rate (HR). Shown are maximal and minimal changes in heart rate after right renal artery (RRA) electrical stimulation; baseline measures, as well as maximal and minimal heart rates after the stimulation are shown.

[0110] FIG. 11 shows the decreases in heart rate once intra-renal artery stimulations were applied to certain locations of renal artery.

[0111] FIG. 12A shows Changes in Arterial Systolic Pressure (ASP) during Four Separated Renal Ablation in Left Renal Artery. Shown are the changes in arterial systolic pressure (ASP, as measured in mmHg) during four separate renal ablations in the left renal artery (LRA).

[0112] FIG. 12B shows Changes in Arterial Diastolic Pressure (ADP) during Four Separated Renal Ablation in Left Renal Artery. Shown are changes in arterial diastolic pressure (ADP, as measured in mmHg) during four separate renal ablations in the left renal artery (LRA).

[0113] FIG. 12C shows Changes in Mean Arterial Pressure (MAP) during Four Separated Renal Ablation in Left Renal Artery. Shown are changes in mean arterial pressure (MAP, as measured in mmHg) during four separate renal ablations in the left renal artery (LRA).

[0114] FIG. 12D shows Changes in Heart Rate (HR) during Four Separated Renal Ablation in Left Renal Artery. Shown are changes in heart rate during four separate renal ablations in the left renal artery (LRA).

[0115] FIG. 13A shows Changes in Arterial Systolic Pressure (ASP) during Four Separated Renal Ablation in Right Renal Artery. Shown are changes in arterial systolic pressure (ASP, as measured in mmHg) during four separate renal ablations in the right renal artery (RRA).

[0116] FIG. 13B shows Changes in Arterial Diastolic Pressure (ADP) during Four Separated Renal Ablation in Right Renal Artery. Shown are changes in arterial diastolic

pressure (ADP, as measured in mmHg) during four separate renal ablations in the right renal artery (RRA).

[0117] FIG. 13C Changes in Mean Arterial Pressure (MAP) during Four Separated Renal Ablation in Right Renal Artery. Shown are changes in mean arterial pressure (MAP, as measured in mmHg) during four separate renal ablations in the right renal artery (RRA).

[0118] FIG. 13D shows Changes in Heart Rate (HR) during Four Separated Renal Ablation in Right Renal Artery. Shown are changes in heart rate during four separate renal ablations in the right renal artery (RRA).

[0119] FIG. 14 shows the experimental setup for the chronic renal nerve ablation experiments.

[0120] FIG. 15 shows histology map scheme for renal artery sections taken from sacrificed animals.

[0121] FIG. 16 shows the systolic blood pressure changes as a result of electrical stimulation at various locations (RA: Renal Artery; AA: Abdominal Aorta).

[0122] FIG. 17A shows the ablation scheme of a full length ablation in an embodiment of this invention; each gray circle on the renal artery represents an ablation site.

[0123] FIG. 17B shows the ablation scheme of a proximal ablation in an embodiment of this invention; each gray circle on the renal artery represents an ablation site.

[0124] FIG. 18A shows the reduction in blood pressure as a result of full length ablation in an embodiment of this invention.

[0125] FIG. 18B shows the reduction in blood pressure as a result of proximal ablation in an embodiment of this invention.

[0126] FIG. 19A shows the distribution of the length of the left main renal arteries (mRA) in a Chinese sample population. The average length of the left mRAs was 28.46 ± 12.09 mm. From 1 mm to 70 mm, the length was divided into 14 sections with an interval of 5 mm. People with left main renal arteries having 25-30 mm in length constituted the largest group (18.6%) in this population.

[0127] FIG. 19B shows the distribution of the length of the right main renal arteries (mRA) in a Chinese sample population. The average length of the right mRAs was 35.94 ± 15.57 mm. From 1 mm to 70 mm, the length was divided into 14 sections with an interval of 5 mm. The length of right mRA was relatively diversified compared with the left mRAs. People with right main renal arteries having 40-45 mm in length constituted the largest group (16.4%) in this population.

[0128] FIG. 20A shows the distribution of the diameters of left main renal arteries at the ostium in a Chinese sample population.

[0129] FIG. 20B shows the distribution of the diameters of left main renal arteries at $\frac{1}{3}$ the length of the renal arteries in a Chinese sample population.

[0130] FIG. 20C shows the distribution of the diameters of left main renal arteries at $\frac{2}{3}$ the length of the renal arteries in a Chinese sample population.

[0131] FIG. 20D shows the distribution of the diameters of left main renal arteries at the furcation of the renal arteries in a Chinese sample population.

[0132] FIG. 20E shows the distribution of the diameters of right main renal arteries at the ostium in a Chinese sample population.

[0133] FIG. 20F shows the distribution of the diameters of right main renal arteries at $\frac{1}{3}$ the length of the renal arteries in a Chinese sample population.

[0134] FIG. 20G shows the distribution of the diameters of right main renal arteries at $\frac{2}{3}$ the length of the renal arteries in a Chinese sample population.

[0135] FIG. 20H shows the distribution of the diameters of right main renal arteries at the furcation of the renal arteries in a Chinese sample population.

[0136] FIG. 21A shows a catheter tip comprising a one-loop spiral-shaped structure 2100 having a plurality of electrodes 2101 in one embodiment of this invention.

[0137] FIG. 21B shows the same catheter tip in FIG. 21A as view from the distal end comprising a one-loop spiral-shaped structure 2100 having a plurality of electrodes 2101.

[0138] FIG. 21C shows a catheter tip comprising a two-loop spiral pyramid-shaped structure 2110 having a plurality of electrodes 2111 in one embodiment of this invention.

[0139] FIG. 21D shows the same catheter tip in FIG. 21C as view from the distal end comprising a two-loop spiral pyramid-shaped structure 2110 having a plurality of electrodes 2111.

[0140] FIG. 22A shows a catheter tip in one embodiment of this invention comprising resilient members 2200 having a plurality of electrodes 2201. The resilient members 2200 are attached to a controlling shaft 2203 at their proximal ends. The resilient members 2200 are retracted into a tubular structure 2204.

[0141] FIG. 22B shows the same catheter tip in FIG. 22A with the resilient members 2200 and electrodes 2201 pushed out of the tubular structure 2204 by the controlling shaft 2203.

[0142] FIG. 22C shows a catheter tip with modification to the embodiment in FIG. 22A. A controlling ring 2205 sheaths the resilient members 2200 and can be used to control the amount of expansion of the resilient members 2200 when the resilient members 2200 and electrodes 2201 are pushed out of the tubular structure 2204 by the controlling shaft 2203.

[0143] FIG. 23A shows a catheter tip in one embodiment of this invention comprising resilient members 2300 having a plurality of electrodes 2301. The resilient members 2300 are attached to a controlling shaft 2303 at their proximal ends while their distal ends are attached to a controlling rod 2305. The resilient members 2300 are retracted into a tubular structure 2304.

[0144] FIG. 23B shows the same catheter tip in FIG. 23A with the resilient members 2300 pushed out of the tubular structure 2304 by the controlling shaft 2303 without pulling back on the controlling rod 2305.

[0145] FIG. 23C shows the same catheter tip in FIG. 23A with the resilient members 2300 pushed out of the tubular structure 2304 by the controlling shaft 2303. The controlling rod 2305 is pulled back to cause bulging of the resilient members 2300.

[0146] FIG. 24 shows an embodiment of the catheter design for proximal ablation where a single catheter has a first set of electrodes 2411 for electrical stimulation and a second set of electrodes 2421 for ablation.

[0147] FIG. 25 shows an embodiment of the catheter design for proximal ablation where one catheter 2510 is used for electrical stimulation and another catheter 2520 is used for ablation.

[0148] FIG. 26 shows the changes in physiological parameters when using the catheter in one embodiment of this invention.

DETAILED DESCRIPTION OF THE
INVENTION

[0149] Please note that as referred to throughout this specification, the term “catheter” references the entire length of a catheter apparatus, from the distal portion intended for introduction into the desired target anatomy for ablation or other action, extending through to the juncture where the catheter meets the cable linking the catheter to an RF generator. As referenced to through this specification, the term “catheter tip” is used to reference the distal portion of the catheter which carries electrodes, and performs stimulation, ablative, and mapping functions within the body at a targeted site of action. The term “catheter tip” is used interchangeably with terms referencing the “distal portion” of any recited catheter.

[0150] The renal nerve architecture is of paramount consideration before successful ablation can take place; therefore, individual renal nerve architecture must be carefully considered or mapped before catheterization for denervation can be successfully accomplished. The presence of aberrant or unusual renal architecture, as well as normal variation in renal nerve architecture among individuals require mapping of the renal nerves before ablation. In other words, mapping of the renal nerves is required before catheter denervation because the best spots for ablation are “random” in the sense that the best spots for ablation vary from one person to another, and from one artery to another. Optimal ablation thus requires identification or mapping of renal nerves prior to catheter ablation.

[0151] This invention provides a system and method for locating sites innervated with functional nerves in the wall of arteries, particularly the renal artery, though persons skilled in the art will appreciate that nerves innervating other arteries or vessels in the human body may be located using this invention. The system comprises one or more devices capable of delivering a dose of energy to the wall of an artery; one or more sensors to receive inputs of physiological signals; one or more devices for analysis of signals from the sensors; and one or more indicators or panels capable of displaying the results of the analysis.

[0152] FIG. 1 depicts an exemplary system in accordance with an aspect of the invention, namely a renal denervation system using blood pressure and heart rate as the physiological parameters for identifying nerve response. The system comprises one or more of devices 101 for delivery of energy to the arterial wall which is in electrical communication with a power source 102. System further comprises sensors 103 for detecting physiological signals in electrical communication with device 104 for analysis of the physiological signals. The indicator 105 in electrical communication with device 104 displays the result of the analysis from device 104. Device 101, in the form of a dual-function catheter, is shown inserted into the renal artery via minimal invasive interventional procedure in this embodiment. At least one of the electrodes of device 101 contacts the renal arterial wall at a defined location and is capable of delivering a dose of energy from the power source 102 for stimulation or ablation of the nerves that may be innervating the area of the arterial wall for which the electrode is in contact with. Sensors 103 detect changes in blood pressure and/or heart rate as energy sufficient for nerve stimulation or ablation is delivered from an electrode on device 101 to the spot the electrode is contacting on the arterial wall. The signals from sensor 103 will be inputted to device 104 which will

determine digitally whether the signal elicited is due to sympathetic or parasympathetic nerves, or the lack thereof. Indicator 105 will then display the result of the analysis from device 104.

[0153] In one embodiment of the invention, device 101 is an invasive device inserted into an artery capable of delivering energy to a nerve innervating the artery, resulting in nerve stimulation or ablation. In another embodiment, device 101 is made up of two separate entities, one delivering the energy for nerve stimulation, and the other nerve ablation. In a different embodiment, device 101 is a single-electrode catheter or multi-electrode catheter.

[0154] In one embodiment, power source 102 delivers energy to the arterial wall via device 101. In another embodiment, energy is delivered remotely through the human body by power source 102 into the arterial wall without device 101. In a further embodiment, power source 102 is a multi-channel power source capable of delivering separate doses of energy independently to distinct locations on the arterial wall. In other embodiments, power source 102 is a single channel power source capable of delivering only 1 dose of energy each time. In another embodiment, the dosage of energy to be delivered by power source 102 is adjustable to induce different effects on a targeted nerve such as stimulation or ablation. In further embodiments, the energy delivered by power source 102 is one or more of electrical, mechanical, ultrasonic, radiation, optical and thermal energies.

[0155] In one embodiment, sensors 103 detect signals from physiological parameters comprising blood pressure, heart rate, levels of biochemicals such as epinephrine, norepinephrine, renin-angiotensin II and vasopressin, cardiac electrical activity, muscle activity, skeletal nerve activity, action potential of cells and other measurable reactions as a result of the above such as pupil response, electromyogram and vascular constriction. In a further embodiment, sensors 103 detect said signals externally with or without contacting any part of the human body. In another embodiment, sensors 103 detect said signals inside the human body by placing into contact with, or in the vicinity of, the lumen of interest such as the renal artery or femoral artery or any other artery. In yet another embodiment, sensor 103 could be a sensor from part of another equipment that is used in conjunction with this invention during the interventional procedure.

[0156] In an embodiment, device 104 is one or more microcontrollers or computers capable of digital analysis of the signals arising directly or indirectly from sensor 103.

[0157] In one embodiment, indicator 105 is one or more digital viewing panels that display the result from the analysis of device 104. In another embodiment, one or more results of said analysis from multiple locations on the arterial wall are simultaneously displayed on indicator 105. In a further embodiment, indicator 105 also displays one or more the physiological signals from sensor 103; energy related information from power source 102 such as current, frequency, voltage; tissue-electrode interface related information such as impedance; and information related to device 101 such as temperature. In certain embodiments, indicator 105 comprises a set of different colored lights each distinctly representing sympathetic nerve, parasympathetic nerve or no nerve. In other embodiments, indicator 105 represents the result from analysis of device 104 with texts, symbols, colors, sound or a combination of the above.

[0158] In certain embodiments, device 104 and indicator 105 are integrated as a single device and, in further embodiments, both device 104 and indicator 105 are integrated into power source 102.

[0159] In yet another embodiment, sensor 103, device 104 and indicator 105 exist independently from device 101 and power source 102 such that sensor 103, device 104 and indicator 105 can be used with other external or invasive methods for energy delivery into the vessel wall such as high-intensity focused ultrasound.

[0160] The present invention additionally provides a method for identifying the presence of functional sympathetic or parasympathetic nerves innervating a selected area on the arterial wall based on changes in physiological parameters induced by a dose of energy. The method comprises one or more of the steps of preparing a baseline of the physiological parameters to be measured prior to the delivery of a dose of energy to the arterial wall; delivering a dose of energy to the arterial wall; detecting the physiological changes as a result of the delivered energy; rating the change based on a set of empirically pre-determined values; and, based on the ratings, determining if there are functional sympathetic or parasympathetic nerves in the vicinity of the site of energy delivery.

[0161] FIG. 2 is a flow chart illustrating the steps of the method for determining the presence of any functional sympathetic or parasympathetic nerve innervating a selected area of an arterial wall.

[0162] At step 1, physiological signals from sensor 103 are continuously recorded by device 104 to produce a reliable baseline reflective of any instantaneous changes in the signals.

[0163] Energy is then delivered by one of the electrodes in device 101 to the area on the arterial wall that this electrode is in contact with (step 2). Sensor 103 detects any physiological change caused by the energy delivered, and the change is recorded as signals which are then sent to device 104. (step 3)

[0164] In step 4, device 104 determines the deviation of the physiological signals from the baseline of step 1 and, in step 5, determines the type of nerves innervating the area on the arterial wall based on the deviation from the baseline information.

[0165] In one embodiment, the physiological signals detected by sensor 103 comprises one or more of blood pressure, heart rate, levels of biochemicals such as epinephrine, norepinephrine, renin-angiotensin II and vasopressin, cardiac electrical activity, muscle activity, skeletal nerve activity, action potential of cells and other observable body reactions as a result of the above such as pupil response and vascular constriction.

[0166] In an embodiment, the dosage of energy delivered in step 2 is adjustable to induce different interactions with a targeted nerve such as nerve stimulation or nerve ablation.

[0167] In certain embodiments, the values of the physiological signals are measured using other external devices and inputted into device 104 prior to the energy delivery to replace the baseline formed by device 104.

[0168] In one embodiment, the changes in physiological parameters are detected during or after the energy delivery process in step 2. In another embodiment, the changes in physiological parameters are in the form of numerical values

or waveforms. In further embodiments, the deviation from baseline of step 1 is evaluated by subtracting the baseline of step 1 from the signals.

[0169] In one embodiment, the empirically pre-determined set of values could be obtained from sets of clinical data or deduced from the experience of clinical physicians. In some embodiments, an area on the arterial wall is considered to be innervated with sympathetic nerves when energy delivered to the area causes an increase in heart rate by 10 beats per minute and/or an increase in blood pressure by 6 mmHg. In other embodiments, an area on the arterial wall is considered to be innervated with parasympathetic nerves when energy delivered to the area causes a decrease in heart rate by 5 beats per minute and/or a decrease in blood pressure by 2 mmHg.

[0170] In a further embodiment, the results of step 5 will be displayed on indicator 105.

[0171] In one embodiment, the method is used for identifying the suitable sites for nerve ablation in the arterial wall to disrupt baroreflex via sympathetic and parasympathetic nervous systems. In another embodiment, the method provides indication of whether the ablation energy is delivered accurately to the targeted nerves in the arterial wall. In a further embodiment, the method is used for immediate post-procedural assessment of nerve ablation.

[0172] In another embodiment, a map of the innervated areas in a blood vessel is obtained by repeated application of said method throughout the entire inner wall of a blood vessel. In a further embodiment, said map generated can be correlated to the 3 dimensional (3D) structure of the blood vessel as obtained using pre-determined data from tomographic imaging techniques such as magnetic resonance imaging, computed tomography or ultrasound so as to display a 3D image of the innervated areas to the physicians during an interventional procedure. The instantaneous position of the catheter in a blood vessel could be imaged by means of live imaging techniques such as X-ray or ultrasound during the interventional procedure. In yet another embodiment, advanced image processing techniques correlate the 3D structure of the blood vessel with the instantaneous position of the mapping catheter and hence, establish the relationship between electrical stimulation locations, the nerve innervation, ablation locations and 3D structure of the blood vessel.

[0173] The present invention also provides for specially-designed catheters with a steerable distal end (i.e. the catheter tip) in shapes customized to renal architecture, possessing one or more electrodes to map renal nerve distribution, to perform renal ablations and to perform angiography. In certain embodiments, the electrodes of such catheters are sequentially spaced along the length of the catheter tip, where the electrode faces make contact with segmented portions of the renal artery lumen. In certain embodiments, the shape of the catheter tip is a single helix wherein the coil of the helix is either round or flat in shape (FIGS. 3A-J). In other embodiments, the catheter tip is a double helix wherein the coils of the helices are either round or flat in shape (FIGS. 4A-F). In further embodiments, the catheter tip may comprise a balloon around which is wrapped a helical coil, wherein spaced along the length of the helical coil are electrodes (FIG. 5A); alternately, the catheter tip may comprise a balloon around which is an umbrella component encapsulating the balloon, and wherein spaced along the umbrella component are electrodes (FIG.

5B). In variations of both embodiments shown in FIGS. 5A and 5B, the coil or umbrella component may be either round or flat in shape; consequently the electrodes spaced along the length of the coil or umbrella may be round or flat in shape, depending upon the underlying shape of the coil or umbrella.

[0174] In further embodiments, the catheter tip may comprise an umbrella shape or frame with a closed end (FIGS. 6A-B), or umbrella with an open end (FIG. 6C-D).

[0175] In another embodiment, the catheter has a steerable catheter tip with a single electrode at its tip (FIG. 7A-B).

[0176] In certain embodiments, the above catheter tips may be introduced into the arterial architecture to perform the functions of a stent.

[0177] In one embodiment, the diameter of these catheter tips, d , may vary from 0.5 mm to 10 mm; the length of the catheter tips, L , may vary from 20 mm to 80 mm; the diameters of coil, D , may vary from 3.0 mm to 7.5 mm; the distances between each coil, l , may vary from 4 mm to 6 mm; the numbers of coils may vary from 3.3 to 20; and the fully uncoiled lengths of the coils may vary from 31 mm to 471 mm.

[0178] The electrodes of the catheters may be activated independently of one another or can be activated in any combination to emit electrical stimulation or radiofrequency energy. The electrodes each have dual functions of delivering electrical stimulation or radiofrequency energy. Electrical stimulation is used to identify and map segments of renal artery lumen beneath which lie renal nerves of importance. Said identification and mapping is accomplished through the monitoring of a physiological response or responses to the applied electrical stimulation, such as changes in blood pressure response and heart rate or muscle sympathetic nerve activity (Schlaich et al., NEJM 2009), or renal norepinephrine spillover (Esler et al. 2009, and Schlaich et al., J Htn. 2009), wherein changes in physiological response indicate the presence of an underlying sympathetic nerve distribution in the vicinity of the activated electrode. In another embodiment, individual electrodes of the catheters may be activated in physician operator-selected combinations in order to assess maximal physiological response, and the consequent locations of underlying renal nerves. The electrodes of the catheters are able to emit not just electrical current of sufficient strength to stimulate renal nerve, but thermal energy such as radiofrequency energy to ablate underlying renal nerve tissue based on renal nerve mapping results. In other embodiments, separate electrodes of the catheters can be selectively activated to emit ablative energy such as high radiofrequency energy wherein the choice of the activated electrodes is based upon the results of the mapping of the nerves. In further embodiments, based on the mapping of the renal nerves, ablative techniques using other types of ablative energy such as laser energy, high intensive focused ultrasound or cryoablative techniques can be utilized on renal artery walls to ablate the sympathetic renal nerves.

[0179] In certain embodiments, these catheters are interchangeably used with existing radiofrequency generators which are presently utilized with existing cardiac catheter systems.

[0180] In one embodiment, the aforementioned catheter systems may be utilized with any variety of acceptable catheter guidewire previously inserted into the patient's body to guide the catheter tip to the desired location. They may also be used with devices and other instruments that

may be used to facilitate the passage of like devices within the cardiovascular and renal vascular systems, such as sheaths and dilators. When required, the aforementioned catheter systems may also be utilized with a puller wire to position the catheter tip.

[0181] The present invention also provides methods of using the catheters described herein to map renal nerve distribution, comprising the steps of using electrical stimulation while monitoring changes in physiological responses, such as blood pressure and heart rate, to map renal nerve distribution and identify ablation spots within renal arteries for ideal denervation of renal nerves. These methods comprise activating the independent electrodes of the described catheters to emit an electrical charge to stimulate the underlying renal nerve while monitoring physiological responses such as blood pressure and heart rate; the presence of changes in physiological response indicate the presence of an underlying sympathetic nerve in the vicinity of the activated electrode and a superior location for ablation. An agglomeration of mapping data may take the form of a clinically useful guide respecting renal nerve distribution to assist clinicians in performing ablation.

[0182] In one embodiment, the tip of said catheter is optionally moved in a blood vessel according to a specified protocol in order to make contact with desired portions of the renal artery lumen. In one embodiment, the optional protocol for moving the catheter tip in the above method comprises moving the stimulatory or ablative section of the catheter tip from the half of the renal artery closer to the interior of the kidney to the half of the renal artery closer to the aorta and applying one or more electrical stimulation to each of the two halves.

[0183] In another embodiment, the optional protocol for moving the catheter tip comprises turning the stimulatory or ablative section of the catheter tip within the renal artery in the following sequence: (a) turning from the anterior wall to the posterior wall of the artery; (b) turning from the posterior wall to the superior wall of the artery; and (c) turning from the superior wall to the inferior wall of the artery, wherein each turn is 90° or less. In one embodiment, one or more electrical stimulations are applied after each turning of the catheter tip within the renal artery.

[0184] In one embodiment, the electrical stimulation applied falls within the following parameters: (a) voltage of between 2 to 30 volts; (b) resistance of between 100 to 1000 ohms; (c) current of between 5 to 40 milliamperes; (d) applied between 0.1 to 20 milliseconds; (e) total applied time is between 1 to 5 minutes.

[0185] The present invention also provides a method of ablating renal nerves to treat disease caused by systemic renal nerve hyperactivity, comprising the steps of: (a) applying the mapping method described herein to map renal nerves; (b) applying radiofrequency energy through the catheter to site-specific portions of the renal artery lumen to ablate the mapped renal nerves; and (c) applying stimulation again to assess the effectiveness of ablation. In further embodiments, based on the mapping of the renal nerves, other ablative techniques generally known in the art can be utilized on renal artery walls to ablate the sympathetic renal nerves, e.g. ablative techniques using other ablative energy such as laser energy, high intensive focused ultrasound or cryoablative techniques.

[0186] The present invention also provides a method for locating or identifying a functional nerve innervating the

wall of a blood vessel in a subject, comprising the steps of a) Delivering energy to one or more locations on said vessel wall sufficient to change one or more physiological parameters associated with the innervation of said vessel by a sympathetic or parasympathetic nerve; and b) Measuring said one or more physiological parameters after each delivery of energy, and determining the change from the corresponding parameters obtained without energy delivery to said vessel; wherein a lack of change in said physiological parameters in step b indicates the absence of a functional nerve at the location of energy delivery, a significant change in said physiological parameters in step b indicates the presence of a functional nerve at the location of energy delivery and the direction of change in said physiological parameters in step b determines the nerve to be sympathetic or parasympathetic at the location of energy delivery. In one embodiment, the blood vessel is an artery, including a renal artery. In one embodiment, the functional nerve is related to baroreflex. In another embodiment, the subject of the method is a human or non-human animal. It is to be understood that a lack of change means that the change would be considered by someone skilled in the art to be negligible or statistically insignificant, and a significant change means that the change would be considered by someone skilled in the art to be meaningful or statistically significant.

[0187] In one embodiment, the method used for locating or identifying a functional nerve innervating the wall of a blood vessel in a subject comprises a step of delivering energy to a location where a nerve has been ablated, wherein a lack of change in said physiological parameters confirms nerve ablation. In one embodiment, the energy delivered is adjustable and consists of electrical, mechanical, ultrasonic, radiation, optical and thermal energies. In another embodiment, the energy delivered causes nerve stimulation or nerve ablation.

[0188] In one embodiment, the physiological parameters described in the method used for locating or identifying a functional nerve innervating the wall of a blood vessel in a subject are selected from blood pressure, heart rate, cardiac electrical activity, muscle activity, skeletal nerve activity, action potential of cells, pupil response, electromyogram, vascular constriction, and levels of biochemicals selected from epinephrine, norepinephrine, renin-angiotensin II and vasopressin. In another embodiment, the functional nerve is a sympathetic or parasympathetic nerve.

[0189] In one embodiment, a system for locating or identifying a functional nerve innervating the wall of a blood vessel in a subject comprises: a) an energy-delivering device configured to deliver energy to one or more locations on said wall sufficient to stimulate a nerve innervating said vessel; b) one or more measuring devices for measuring one or more physiological parameters associated with the innervation of said blood vessel by a sympathetic or parasympathetic nerve, before or after energy is delivered to said nerve by said energy-delivering device; and c) a device configured to couple to the one or more measuring devices for displaying the location and identity of a nerve innervating said vessel wall. In one embodiment, the measuring devices are placed inside the vessel or outside the body. In another embodiment, the measuring devices comprise one or more micro-controllers or computers.

[0190] In one embodiment, said system displays the location and identity of a nerve as numbers, texts, symbols, colors, sound, waveforms, or a combination thereof.

[0191] In one embodiment, said system is used in a method for locating or identifying a functional nerve innervating the wall of a blood vessel in a subject, comprising the steps of a) Delivering energy to one or more locations on said vessel wall sufficient to change one or more physiological parameters associated with the innervation of said vessel by a sympathetic or parasympathetic nerve; and b) Measuring said one or more physiological parameters after each delivery of energy, and determining the change from the corresponding parameters obtained without energy delivery to said vessel; wherein a lack of change in said physiological parameters in step b indicates the absence of a functional nerve at the location of energy delivery, a significant change in said physiological parameters in step b indicates the presence of a functional nerve at the location of energy delivery, and the direction of change in said physiological parameters in step b determines the nerve to be sympathetic or parasympathetic at the location of energy delivery.

[0192] The present invention provides for a catheter adapted to be used in a method to locate or identify a functional nerve innervating the wall of a blood vessel in a subject, comprising a shaft, wherein the proximal end of said shaft is configured to be connected to an energy source, and the distal end (catheter tip) of said shaft is in the form of a single helix, double helix or multiple prongs having one or more electrodes.

[0193] In one embodiment, said catheter comprises one or more electrodes that are configured to emit energy sufficient to stimulate or ablate a nerve on said vessel. In a further embodiment, said electrodes may be activated independently of one another.

[0194] In one embodiment, said catheter is between 1 and 2 m in length, wherein the catheter tip is between 2 and 8 cm in length, and between 0.5 mm and 10 mm in diameter.

[0195] In one embodiment, said catheter contains helical coils or prongs which are substantially round or flat in shape, and the electrodes are spaced along the length of said coils or prongs, wherein said electrodes are embedded in said coils or prongs, or lie on the surface of said coils or prongs. In one embodiment, the prongs are rejoined at the distal end. In yet another embodiment, the electrodes are evenly spaced along the length of said coils at 90° or 120° from each other.

[0196] In one embodiment, said catheter has a catheter tip that is configured to hold a balloon inflatable to fill the space within the coil of said helix or prongs.

[0197] The present invention also provides a method of using a catheter to locate or identify a functional nerve innervating the wall of a blood vessel in a subject, comprising the steps of: a) inserting said catheter into said blood vessel and activating the electrodes on the catheter to deliver energy to one or more locations on said vessel wall sufficient to change one or more physiological parameters associated with the innervation of said vessel by a sympathetic or parasympathetic nerve; and b) measuring said one or more physiological parameters after each energy delivery, and determining the change from the corresponding parameters obtained without energy delivery to said vessel; wherein a lack of change in said physiological parameters in step b indicates the absence of a functional nerve at the location of energy delivery, a significant change in said physiological parameters in step b indicates the presence of a functional

nerve at the location of energy delivery, and the direction of change in said physiological parameters in step b determines the nerve to be sympathetic or parasympathetic at the location of energy delivery. In one embodiment, said vessel is an artery, including a renal artery. In one embodiment, the functional nerve is related to baroreflex. In one embodiment, the location where energy is delivered is an area where a nerve has been ablated, wherein a lack of change in said physiological parameters in step b confirms nerve ablation. In another embodiment, the subject used is a human or non-human animal. In another embodiment, the physiological parameters described are selected from blood pressure, heart rate, cardiac electrical activity, muscle activity, skeletal nerve activity, action potential of cells, pupil response, electromyogram, vascular constriction, and levels of biochemicals selected from epinephrine, norepinephrine, renin-angiotensin II and vasopressin. In yet another embodiment, said energy is adjustable and consists of one or more of electrical, mechanical, ultrasonic, radiation, optical and thermal energies. In one embodiment, said energy causes nerve stimulation or nerve ablation. In another embodiment, the functional nerve is a sympathetic or parasympathetic nerve. In yet another embodiment, the energy delivered falls within the following ranges: a) voltage of between 2 and 30 volts; b) resistance of between 100 and 1000 ohms; c) current of between 5 and 40 milliamperes; d) time of application between 0.1 and 20 milliseconds; e) total applied time is 1 to 5 minutes.

[0198] In one embodiment, said catheter is moved in the blood vessel in the following sequence: a) turning 90° or less from the anterior wall to the posterior wall of the artery; b) turning 90° or less from the posterior wall to the superior wall of the artery; and c) turning 90° or less from the superior wall to the inferior wall of the artery.

[0199] In one embodiment, this invention provides a method for ablation of renal nerve adjacent to a renal artery of a subject, comprising the steps of: a) determining the presence of a renal nerve by i) contacting a first site on the inner renal artery wall with one or more first electrodes; ii) applying a first electrical stimulation by introducing electrical current to said first site via said first electrodes, wherein said electrical current is controlled to be sufficient to elicit changes in one or more physiological parameters when there is an underlying nerve at said first site, said one or more physiological parameters are selected from the group consisting of systolic blood pressure, diastolic blood pressure, mean arterial pressure, and heart rate; and measuring said one or more physiological parameters after said first electrical stimulation, wherein an increase of said physiological parameters as compared to measurements obtained before said first electrical stimulation would indicate the presence of a renal nerve; b) contacting a second site on the inner renal artery wall with one or more second electrodes, said second site is proximal to the ostium of said renal artery as compared to said first site; c) delivering ablation energy to said second site via said second electrodes; and d) applying a second electrical stimulation to said first site via said first electrodes and measuring said physiological parameters after said second electrical stimulation, wherein no increase of said physiological parameters after said second electrical stimulation indicates ablation of renal nerve in said subject.

[0200] In one embodiment, the method further comprising repetition of steps (b) to (d) at a new second site if ablation at an original second site did not ablate the renal nerve in said subject.

[0201] In one embodiment, prior to delivering ablation energy at step (c), electrical stimulation is applied to said second site by said one or more second electrodes, wherein ablation energy is only delivered when said electrical stimulation elicits an increase of said physiological parameters as compared to measurements obtained before said electrical stimulation.

[0202] In one embodiment, the second site is a site within one-third the length of said renal artery adjacent to the ostium.

[0203] In one embodiment, the first electrodes and second electrodes are located on a single catheter.

[0204] In one embodiment, the first electrodes and second electrodes are located on different catheters.

[0205] In one embodiment, the electrical current has one or more of the following parameters: a) voltage between 2 and 30 volts; b) resistance between 100 and 1000 ohms; c) current between 5 and 40 milliamperes; d) time of application between 0.1 and 20 milliseconds; and e) total applied time between 1 to 5 minutes.

[0206] In one embodiment, the first electrodes or second electrodes are located on a catheter comprising an expandable tip at its distal end. In another embodiment, the expandable tip when viewed from the distal end has a diameter in the range of 3.5 mm to 20 mm. In a further embodiment, the expandable tip comprises a tubular structure that houses one or more resilient members with pre-formed curvatures, wherein said first or second electrodes are disposed on said one or more resilient members, said one or more resilient members are attached at their proximal ends to a controlling shaft, wherein movement of said controlling shaft causes said one or more resilient members to be pushed out of said tubular structure to resume the pre-formed curvature or retracted into said tubular structure.

[0207] In one embodiment, the first or second electrodes are disposed on a section of a catheter having a configuration comprising a spiral having one or more loops. In another embodiment, the configuration comprises a spiral pyramid with the loops becoming progressively smaller from a proximal end to a distal end.

[0208] In one embodiment, this invention provides a catheter for mapping and ablating renal nerves distributed on the renal artery, comprising: a) a first set of electrodes comprising one or more electrodes configured to deliver one or both of electrical stimulation and ablation energy; b) a second set of electrodes comprising one or more electrode configured to deliver one or both of electrical stimulation and ablation energy; wherein said first and second sets of electrodes are located at a distal end of said catheter, said first set of electrodes is nearer to the distal end of said catheter in comparison to said second set of electrodes.

[0209] In one embodiment, the relative distance between said first set of electrodes and said second set of electrodes can be adjusted.

[0210] In one embodiment, the distal end of said catheter is in a configuration to enable said first set of electrodes or said second set of electrodes to contact renal artery wall at multiple sites, wherein said configuration when viewed from the distal end has a diameter in the range of 3.5 mm to 20 mm.

[0211] In one embodiment, the first or second set of electrodes is disposed on said distal end having a configuration comprising a spiral having one or more loops. In another embodiment, the configuration comprises a spiral pyramid with the loops becoming progressively smaller from a proximal end to a distal end.

[0212] In one embodiment, the distal end of said catheter comprises a tubular structure that houses one or more resilient members with pre-formed curvatures, wherein said first or second set of electrodes is disposed on said one or more resilient members, said one or more resilient members are attached at their proximal ends to a controlling shaft, wherein movement of said controlling shaft causes said one or more resilient members to be pushed out of said tubular structure to resume the pre-formed curvature or retracted into said tubular structure. In another embodiment, the catheter further comprises a controlling ring that sheaths said one or more resilient members, wherein movement of said controlling ring along said resilient members controls the extend said one or more resilient members resumes its pre-formed curvature. In a further embodiment, the catheter further comprises a controlling rod within said controlling shaft, wherein the distal end of said controlling rod is attached to the distal ends of said one or more resilient members, wherein retracting said controlling rod after said one or more resilient members are pushed out of said tubular structure will cause said one or more resilient members to bulge out at their middle.

[0213] It will be appreciated by persons skilled in the art that the catheter, system and method disclosed herein may be used in nerve ablation of the renal artery to disrupt baroreflex via sympathetic and parasympathetic nervous systems but its application could be extended to any innervated vessels in the body.

[0214] The invention will be better understood by reference to the Experimental Details which follow, but those skilled in the art will readily appreciate that the specific examples are for illustrative purposes only and should not limit the scope of the invention which is defined by the claims which follow thereafter.

[0215] It is to be noted that the transitional term “comprising”, which is synonymous with “including”, “containing” or “characterized by”, is inclusive or open-ended and does not exclude additional, un-recited elements or method steps.

Example 1

Locating Nerves Innervating an Arterial Wall

[0216] A method to locate nerves innervating an arterial wall via examination of the changes in physiological parameters after the delivery of a suitable dose of energy was designed and executed in acute pig experiments. The aims of this experiments are:

[0217] 1. To test currently existing cardiac ablation catheters (7F,B-Type, spacing 2-5-2 mm, CELSIUS® RMT Diagnostic/Ablation Steerable Catheter, Biosense Webster, Diamond Bar, Calif. 91765, USA) and a radiofrequency generator (STOCKERT 70 RF Generator, Model Stockert GmbH EP-SHUTTLE ST-3205, STOCKERT GmbH, Freiburg, Germany) for the purposes of renal nerve mapping and ablation.

[0218] 2. To test renal nerve mapping via examination of changes in blood pressure and heart rate during emission of electrical stimulation at different sites within the lumen of the left and right renal arteries.

[0219] 3. To determine the safe range of high radiofrequency energy to be emitted to renal arteries for renal nerve ablation via examination of visual changes of renal arterial walls and histology.

[0220] 4. To use changes in blood pressure and heart rate as indices of efficient ablation of renal nerves during renal ablation.

[0221] Three pigs (body weight from 50-52 kg) were anesthetized with intravenous injection of sodium pentobarbital at 15 mg/kg. The physiological parameters: systolic blood pressure, diastolic blood pressure, mean arterial pressure and heart rate were monitored. The experimental design and protocol are illustrated in FIG. 8.

[0222] The ablation catheter used in this set of experiments was the 7F,B-Type, spacing 2-5-2 mm, CELSIUS® RMT Diagnostic/Ablation Steerable Catheter (Biosense Webster, Diamond Bar, Calif. 91765, USA) and a Celsius radiofrequency generator (STOCKERT 70 RF Generator, Model Stockert GmbH EP-SHUTTLE ST-3205, STOCKERT GmbH, Freiburg, Germany).

[0223] Baselines for systolic, diastolic and mean arterial blood pressure and heart rate were measured before the delivery of electrical energy to different areas of the renal arterial wall. Mean arterial blood pressure and heart rate were then measured 5 seconds to 2 minutes after the delivery of energy to note for any effects. By recognizing that a significant change in blood pressure and heart rate to be associated with nerve stimulation, it was found that, although the segment of the arterial wall that is innervated varies in each animal, the method described herein has correctly located these areas in each of the animals giving a map of the innervated regions in the renal artery.

Example 2

Relationship Between Physiological Parameters and the Nerves Innervating an Arterial Wall

[0224] In order to demonstrate that energy delivered to different locations on an arterial wall may result in different effects on physiological parameters such as blood pressure and heart rate, and such characteristics can be capitalized on to identify the type of nerve innervating an arterial wall, electrical energy was delivered to the innervated areas on the renal arterial walls of the pig model according to several strategies. Detailed parameters on the electrical energy delivered to Pig #1, Pig #2 and Pig #3 are shown in Table 1, Table 2 and Table 3 respectively.

[0225] In Pig #1, four separate stimulations took place in the left renal artery and two separate stimulations were performed in the right renal artery. As preliminary approaches, on the abdominal side of the left renal artery, two separate doses of electrical energy were delivered: one to the anterior wall and one to the posterior wall of the artery. On the kidney side of the left renal artery, two separate doses of electrical energy were delivered: one to the anterior wall and one to the posterior wall of the artery. Different effects of these energies on blood pressure and heart rate were observed. In the right renal artery, one dose of electrical energy was delivered to the renal artery on the abdominal side and the kidney side, respectively. The same stimulation strategy was used for Pig #2 and Pig #3.

[0226] The electrical energy delivered to different locations in the renal artery caused different effects on the systolic blood pressure, diastolic blood pressure, mean blood pressure and heart rate in all of the pigs tested. For instance, in response to the electrical energy delivered to the left kidney, the maximal change in systolic blood pressure was

respectively 19.5 mmHg and 29 mmHg in Pig #1 and Pig #3; the minimal change of systolic blood pressure was respectively 2 mmHg and 1 mmHg in Pig #1 and Pig #3. However, in Pig #2, changes in systolic blood pressure were consistent when the electrical energy was delivered to either the abdominal aorta side or the kidney side. Furthermore, the stimulation location which caused the maximal effect or minimal effect varied from animal to animal, indicating that the distribution of renal autonomic nerves is not consistent between animals. These phenomena in systolic blood pressure, diastolic blood pressure, mean arterial blood pressure and heart rate during delivery of electrical energy to wall of the left renal artery were observed and further summarized in Table 4A, 4B, 4C and 4D, respectively. Similar phenomenon in systolic blood pressure, diastolic blood pressure, mean arterial blood pressure and heart rate during electrical stimulation in the right renal artery were also observed and further summarized in Table 5A, 5B, 5C and 5D, respectively.

[0227] These data provide proof of concept for locating and identifying nerves innervating an arterial wall—specifically, that a substantial physiological response, in this case, the maximal increase or decrease in measured blood pressure, was induced by delivery of electrical energy via a catheter placed at a defined location where renal nerve branches are abundantly distributed. Averaged data (mean±SD) calculated from Table 4A-D and Table 5A-D are graphically represented in FIG. 9 and FIG. 10, inclusive of all sub-figures.

TABLE 1

Renal Nerve Stimulation for Mapping Pig #1:			
Renal Artery	Stimulation Site		Stimulation Parameters
Left	Kidney side	Anterior	15 V; 0.4 ms; 400 Ohm; 17 mA
		Wall	

TABLE 1-continued

Renal Nerve Stimulation for Mapping Pig #1:			
Renal Artery	Stimulation Site		Stimulation Parameters
Right	Abdominal Aorta Side	Posterior Wall	15 V; 0.4 ms; 400 Ohm; 28 mA
		Anterior Wall	15 V; 0.2 ms; 400 Ohm; 28 mA
	Kidney side	Posterior Wall	15 V; 0.2 ms; 540 Ohm; 28 mA
		Anterior Wall	15 V; 0.2 ms; 600 Ohm; 25 mA

TABLE 2

Renal Nerve Stimulation for Mapping Pig #2:			
Renal Artery	Stimulation Site		Stimulation Parameters
Left	Kidney side	Kidney side	15 V; 0.2 ms; 580 Ohm; 26 mA
		Abdominal Aorta Side	15 V; 0.2 ms; 480 Ohm; 28 mA
Right	Kidney side	Kidney side	15 V; 0.2 ms; 520 Ohm; 28 mA
		Abdominal Aorta Side	15 V; 0.2 ms; 500 Ohm; 28 mA

TABLE 3

Renal Nerve Stimulation for Mapping Pig #3:			
Renal Artery	Stimulation Site		Stimulation Parameters
Left	Kidney side	Kidney side	15 V; 9.9 ms; 800 Ohm; 28 mA
		Abdominal Aorta Side	15 V; 9.9 ms; 800 Ohm; 28 mA
Right	Kidney side	Kidney side	15 V; 9.9 ms; 800 Ohm; 28 mA
		Abdominal Aorta Side	15 V; 9.9 ms; 800 Ohm; 28 mA

TABLE 4A

Changes in Systolic Blood Pressure (SBP) During Electrical Stimulation in Left Renal Artery									
Left Renal Stimulation									
SBP	Maximal Responses (mmHg)			Minimal Responses (mmHg)					
	Animal No.	Baseline	Maximal	Δ	Stimulation Location	Baseline	Minimal	Δ	Stimulation Location
	Pig 1	131.5	151	19.5	AO Side	140	142	2	Renal Side
	Pig 2	155	159	4	Renal Side	155	159	4	AO Side
	Pig 3	173	202	29	Renal Side	169	170	1	AO Side
	Average	153.2	170.7	17.5		154.7	157.0	2.3	
	SD	20.8	27.4	12.6		14.5	14.1	1.5	

TABLE 4B

Changes in Diastolic Blood Pressure (DBP) During Electrical Stimulation in Left Renal Artery									
Left Renal Stimulation									
DBP	Maximal Responses (mmHg)			Minimal Responses (mmHg)					
	Animal No.	Baseline	Maximal	Δ	Stimulation Location	Baseline	Minimal	Δ	Stimulation Location
	Pig 1	99	108	9	AO Side	116	117	1	Renal Side
	Pig 2	112	115	3	Renal Side	114	116	2	AO Side

TABLE 4B-continued

Changes in Diastolic Blood Pressure (DBP) During Electrical Stimulation in Left Renal Artery									
Left Renal Stimulation									
DBP	Maximal Responses (mmHg)			Minimal Responses (mmHg)					
	Animal No.	Baseline	Maximal	Δ	Stimulation Location	Baseline	Minimal	Δ	Stimulation Location
	Pig 3	119	139	20	Renal Side	110	115	5	AO Side
	Average	110.0	120.7	10.7		113.3	116.0	2.7	
	SD	10.1	16.3	8.6		3.1	1.0	2.1	

TABLE 4C

Changes in Mean Arterial Pressure (MAP) During Electrical Stimulation in Left Renal Artery									
Left Renal Stimulation									
MAP	Maximal Responses (mmHg)			Minimal Responses (mmHg)					
	Animal No.	Baseline	Maximal	Δ	Stimulation Location	Baseline	Minimal	Δ	Stimulation Location
	Pig 1	112.5	125	12.5	AO Side	123	128	5	Renal Side
	Pig 2	130	133	3	Renal Side	131	132	1	AO Side
	Pig 3	141	158	17	Renal Side	136	138	2	AO Side
	Average	127.8	138.7	10.8		130.0	132.7	2.7	
	SD	14.4	17.2	7.1		6.6	5.0	2.1	

TABLE 4D

Changes in Heart Rate (HR) During Electrical Stimulation in Left Renal Artery									
Left Renal Stimulation									
HR	Maximal Responses (beats/min)			Minimal Responses (beats/min)					
	Animal No.	Baseline	Maximal	Δ	Stimulation Location	Baseline	Minimal	Δ	Stimulation Location
	Pig 1	150	151	1	Renal Side	140	130	-10	Renal Side
	Pig 2	126	132	6	AO Side	132	120	-12	Renal Side
	Pig 3	138	142	4	Renal Side	159	150	-9	AO Side
	Average	138.0	141.7	3.7		143.7	133.3	-10.3	
	SD	12.0	9.5	2.5		13.9	15.3	1.5	

TABLE 5A

Changes in Systolic Blood Pressure (SBP) During Electrical Stimulation in Right Renal Artery									
Right Renal Stimulation									
SBP	Maximal Responses (mmHg)			Minimal Responses (mmHg)					
	Animal No.	Baseline	Maximal	Δ	Stimulation Location	Baseline	Minimal	Δ	Stimulation Location
	Pig 1	151.5	156	4.5	Renal Side	155	158	3	AO Side
	Pig 2	153	166	13	Renal Side	157	162	5	AO Side
	Pig 3	154	167	13	Renal Side	157	162	5	AO Side
	Average	152.8	163.0	10.2		156.3	160.7	4.3	
	SD	1.3	6.1	4.9		1.2	2.3	1.2	

TABLE 5B

Changes in Diastolic Blood Pressure (DBP) During Electrical Stimulation in Right Renal Artery								
Right Renal Stimulation								
Animal No.	Maximal Responses (mmHg)			Stimulation Location	Minimal Responses (mmHg)			Stimulation Location
	Baseline	Maximal	Δ		Baseline	Minimal	Δ	
Pig 1	111.5	113	1.5	Renal Side	113	113	0	AO Side
Pig 2	113	119	6	Renal Side	114	117	3	AO Side
Pig 3	110	113	3	Renal Side	112	110	-2	AO Side
Average	111.5	115.0	3.5		113.0	113.3	0.3	
SD	1.5	3.5	2.3		1.0	3.5	2.5	

TABLE 5C

Changes in Mean Arterial Pressure (MAP) During Electrical Stimulation in Right Renal Artery								
Right Renal Stimulation								
Animal No.	Maximal Responses (mmHg)			Stimulation Location	Minimal Responses (mmHg)			Stimulation Location
	Baseline	Maximal	Δ		Baseline	Minimal	Δ	
Pig 1	130	130	0	AO Side	131	130	-1	Renal Side
Pig 2	130	141	11	Renal Side	132	135	1	AO Side
Pig 3	127	130	3	Renal Side	130	131	1	AO Side
Average	129.0	133.7	4.7		131.0	132.0	1.0	
SD	1.7	6.4	5.7		1.0	2.6	2.0	

TABLE 5D

Changes in Heart Rate (HR) During Electrical Stimulation in Right Renal Artery								
Right Renal Stimulation								
Animal No.	Maximal Responses (beats/min)			Stimulation Location	Minimal Responses (beats/min)			Stimulation Location
	Baseline	Maximal	Δ		Baseline	Minimal	Δ	
Pig 1	141	146	5	AO Side	144	135	-9	Renal Side
Pig 2	135	147	12	Renal Side	120	117	-3	AO Side
Pig 3	129	135	6	Renal Side	126	123	-3	AO Side
Average	135.0	142.7	7.7		130.0	125.0	-5.0	
SD	6.0	6.7	3.8		12.5	9.2	3.5	

TABLE 6

Possible Effects of Stimulating Renal Nerves				
Publication	Animal Model	Change of blood pressure when renal nerve stimulated	Change of heart rate when renal nerve stimulated	
Ueda H, Uchida Y and Kamisaka K, "Mechanism of the Reflex Depressor Effect by Kidney in Dog", Jpn. Heart J., 1967, 8 (6): 597-606	Dog	decrease	N/A	
Beacham WS and Kunze DL, "Renal Receptors Evoking a Spinal Vasometer Reflex", J. Physiol., 1969, 201 (1): 73-85	Cat	decrease	N/A	
Aars H and Akre S, "Reflex Changes in Sympathetic Activity and Arterial Blood Pressure Evoked by Afferent Stimulation of the Renal Nerve", Acta Physiol. Scand., 1970, 78 (2): 184-188	Rabbit	decrease	N/A	

TABLE 6-continued

Possible Effects of Stimulating Renal Nerves			
Publication	Animal Model	Change of blood pressure when renal nerve stimulated	Change of heart rate when renal nerve stimulated
Ma G and Ho SY, "Hemodynamic Effects of Renal Interoreceptor and Afferent Nerve Stimulation in Rabbit", Acta Physiol. Sinica, 1990, 42 (3): 262-268	Rabbit	decrease	Decrease
Lu M, Wei SG and Chai XS, "Effect of Electrical Stimulation of Afferent Renal Nerve on Arterial Blood Pressure, Heart Rate and Vasopressin in Rabbits", Acta Physiol. Sinica, 1995, 47 (5): 471-477	Rabbit	decrease	Decrease

[0228] Among all the stimulation experiments performed in pigs according to the previously described protocol, certain locations in the renal arterial wall led to significant decreases in heart rate without causing changes in the blood pressure or the change in blood pressure is minimal in comparison to the decrease in heart rate (FIG. 11). Slight decreases in blood pressure, especially, diastolic blood pressure were often recorded. Out of the 56 data points inclusive of all 4 physiological parameters evaluated in the experiments, there were at least 1 data point from each physiological parameter that responded with the dose of energy by a drop or no/insignificant change in value; this accounted for over 23% of the data points in this experiment. These distinctive physiological changes in response to the stimulations appear to indicate that nerves innervating these locations are of parasympathetic nature and are different from those sympathetic nerves innervating the locations that results in increases in blood pressure and heart rate upon stimulation. Table 6 summarized the effect of delivering a suitable dose of energy to the afferent renal nerve in different studies involving animal models of dogs, cats and rabbits. In conjunction with this invention, the studies in Table 6 had demonstrated that it is not uncommon to induce effects akin to parasympathetic activity when a suitable dose of energy is delivered to the nerves innervating the kidney. In other words, there is an indication that, in the neural circuitry of the renal artery, there exist nerves that can induce parasympathetic activity rather than sympathetic activity and therefore should not be ablated when treating blood pressure related diseases.

Example 3

Ensuring Energy is Directed to a Target Nerve During Ablation

[0229] Subsequent to the studies for locating and identifying nerves in an arterial wall, energies at dosage suitable for ablations were also delivered to the innervated spots in the renal arterial wall of the same pigs. Four ablations were each delivered to the left and to the right renal arteries starting from the kidney side and moving to the abdominal aorta side in the order of movement from the anterior, to the posterior, to the superior and then to the inferior wall; each ablation was ≤ 5 mm apart from the location of the previous ablation and the electrode head (catheter tip) of the ablation catheter was turned 90 degrees after each ablation. Based on

the literature (Krum 2009, 2010), low energy level (5-8 watts) should be used for renal ablation; therefore, 5 watts and 8 watts were used for renal ablation. For left renal artery ablation, the energy level applied was 5 watts and the time length of ablation was 120 seconds; for the right renal artery, the ablation energy level applied was 8 watts and the time length was 120 seconds. The temperature at the ablation site was measured to be from 40° C. to 50° C. The physiological parameters: systolic blood pressure, diastolic blood pressure, mean arterial pressure and heart rate were examined during ablations. The data clearly showed that ablation at different locations within the renal artery resulted in differing changes in blood pressure and heart rate, further demonstrating that changes in physiological parameters such as blood pressure and heart rate can be used as indicators for an accurate delivery of ablation energy to a targeted nerve and provided further evidence that distribution of the nerves in the arterial wall varied case by case.

[0230] Changes in systolic blood pressure, diastolic blood pressure, mean arterial pressure and heart rate during four separate renal ablations in the renal arteries of the left kidney were summarized in FIGS. 12A, 12B, 12C and 12D, respectively. Changes in arterial systolic and diastolic pressure, mean arterial pressure and heart rate during four separate renal ablations in the renal arteries of the right kidney were summarized in FIGS. 13A, 13B, 13C and 13D, respectively.

Example 4

Chronic Renal Nerve Ablation Experimental Results

[0231] This set of experiments involves methods to determine the safety profile of the energy levels used in existing cardiac ablation catheters in the denervation of renal nerves. FIG. 14 describes the details of this experiment.

[0232] The ablation catheter used in this set of experiments was the 7F,B-Type, spacing 2-5-2 mm, CELSIUS® RMT Diagnostic/Ablation Steerable Catheter (Biosense Webster, Diamond Bar, Calif. 91765, USA) and a Celsius radiofrequency generator (STOCKERT 70 RF Generator, Model Stockert GmbH EP-SHUTTLE ST-3205, STOCKERT GmbH, Freiburg, Germany). Four pigs were used in the study.

[0233] The energy levels used for the ablations applied were as follows: Right Renal Artery Ablation, 8 W, 120 s;

Left Renal Artery Ablation 16 W, 120 s (n=3). Right Renal Artery Ablation, 16 W, 120 s; Left Renal Artery Ablation, 8 W, 120 s (n=3).

[0234] The pigs were anesthetized, and 4-5 renal ablations were performed for each renal artery (right and left) separately. Renal angiography was performed before and after the ablation to examine the patency of renal arteries. Pigs were allowed to recover from the procedures. In order to determine the safety levels of ablation energy, one pig (Right renal artery, 16 W, 120 s; Left renal artery ablation, 8 W, 120 s) was terminated for assessment of acute lesions due to two different energy levels of ablation. Twelve weeks after the ablation procedure, angiography was performed on the animals for both renal arteries. Thereafter, the animals were sacrificed, and renal arteries and kidneys examined for any visible abnormalities; pictures were taken with renal arteries intact and cut open, with both kidneys cut open longitudinally. Samples from both renal arteries were collected for further histology studies according to the histology maps shown in FIG. 15.

Example 5

Renal Mapping Catheter Designs

[0235] New catheters designed with functions of stimulation, mapping, ablation and angiography are hereby disclosed.

[0236] The catheter apparatus comprises an elongated catheter having a catheter tip on the distal end which, once inserted, is intended to remain in a static position within the renal vascular architecture; a proximal end; and a plurality of ablation electrodes. In one embodiment, the ablation electrodes are evenly-spaced down the length of the elongated catheter tip. The plurality of these ablation electrodes are spaced from the proximal end and from the distal end of the elongated catheter tip by electrically nonconductive segments. In one embodiment, the first electrode on the tip side of the catheter or on the end side of the catheter can be used as a stimulation reference for any other electrodes to deliver electrical stimulation; alternatively, any one of these electrodes can be used as a reference for other electrodes.

[0237] In one embodiment, the elongated catheter tip is of a helical shape.

[0238] In another embodiment, one or more conducting wires are coupled with and supplying direct or alternating electrical current to the plurality of electrodes via one or more conducting wires. A controller is configured to control the electrical current to the plurality of electrodes in either an independent manner, or a simultaneous manner while the catheter tip remains in a static position in the renal artery.

[0239] In another embodiment, one or more conducting wires are coupled with and supplying radiofrequency (RF) energy to the plurality of electrodes, the RF energy being either unipolar RF energy or bipolar RF energy. A radiofrequency generator supplies energy via the one or more conducting wires to the plurality of electrodes. A controller is configured to control the energy source to supply energy to the plurality of electrodes in either an independent manner, a sequential manner, or a simultaneous manner while the catheter tip remains in a static position in the renal artery.

[0240] The RF energy sent to the electrodes may be controlled so that only low-level electrical energy impulses are generated by the electrodes in order to merely stimulate underlying nerve tissue, and in particular, renal nerve tissue.

Alternately, the RF energy sent to the electrodes may be controlled so that greater electrical energy impulses are generated by the electrodes in order to ablate underlying nerve tissue, and in particular, renal nerve tissue. The catheter tip, and in particular, the electrodes, are designed to remain in contact with the renal artery lumen, in the same place, throughout stimulation and ablation.

[0241] In another embodiment, the catheter is capable of being used with radiofrequency generators currently utilized in the practice of cardiac tissue ablation. These radiofrequency generators may include, but are not necessarily limited to those currently produced by Medtronic, Cordis/Johnson & Johnson, St. Jude Medical, and Biotronic.

[0242] Exemplary embodiments of the invention, as described in greater detail below, provide apparatuses for renal nerve denervation.

[0243] FIGS. 3 to 7 are examples and illustrations of these ablation catheter and electrodes. Shown are elevational, cross-sectional, and end-on views of a distal portion of the ablation catheter tip according to various embodiments of the present invention.

[0244] In one embodiment, the catheter has an elongated tip of a helical shape. A plurality of electrodes is evenly spaced starting from their placement at the proximal end of the catheter tip through the distal end of the catheter tip by electrically nonconductive segments.

[0245] In certain embodiments, the catheter tip of the ablation catheter comprises a single helix; in others, it is composed of a double helix. The coil or coils of the helix or helices of the catheter tip may be either round or flat. Electrodes may be placed evenly down the length of the coils; for example, they can be spaced either 60°, 90° or 120° apart, but may be placed in other conformations or separated by different degrees.

[0246] In one embodiment, the electrodes may be either flat and rectangular or square in shape, if the coil of a helix is itself flattened. Alternately, the electrodes may be round and/or built into the helix if the coil is itself round. In another embodiment, the catheter tip has a length of from 2.0 cm to 8.0 cm and a diameter of 0.5 mm to 10.0 mm; the diameters of coil may vary from 3.0 mm to 7.5 mm; the distances of each coil may vary from 4 mm to 6 mm; and the fully uncoiled lengths of the coils may vary from 31 mm to 471 mm; the catheter's total length is from 1 m to 2 m.

[0247] In another embodiment, the catheter tip of the ablation catheter comprises a balloon catheter system. In one embodiment, electrodes are evenly spaced at intervals along a helical coil which is either round or flat in shape and wrapped around the balloon; in other embodiments, electrodes are spaced along an umbrella frame apparatus which is either round or flat in shape and wrapped down the length of the balloon. In certain embodiments, the umbrella frame apparatus has an open end and in others, a closed end. The electrodes will come into contact with the renal architecture upon inflation of the balloon apparatus. In one embodiment, the catheter tip has a length of 2.0 cm to 8.0 cm and a diameter from 0.5 mm to 10.0 mm when the balloon is not inflated; the diameters of coil may vary from 3.0 mm to 8 mm; the distances of each coil may vary from 4 mm to 6 mm; the numbers of coils may vary from 3.3 to 20; and the fully uncoiled lengths of the coils may vary from 31 mm to 471 mm. the catheter's total length is from 1 m to 2.0 m.

[0248] In one embodiment, the diameter of the catheter tip when the balloon is inflated may range from 0.5 mm to 10

mm. The diameter of the coil around the balloon may range from 3 mm to 10 mm and the diameter of a fully inflated balloon is from 3 mm to 10 mm.

[0249] The invention may also comprise a catheter tip which is tube-like, cylindrical, and self-expanding with adjustable sizes. The materials used for these catheter tips may, in certain embodiments, comprise nickel-titanium (nitinol) alloy.

[0250] In one embodiment of this invention, there is provided a renal nerve modulation and ablation processes (on either the left side kidney, right side kidney, or both) comprising insertion of one of the catheters described above into either the left renal artery (LRA) or the right renal artery (RRA) followed by renal nerve mapping as substantially described above, followed by targeted ablation by individual electrodes.

[0251] In one embodiment, nerve stimulation takes place by application of the following parameters: 0.1 ms-20 ms, 2V-30V, 5 mA-40 mA, and 100 Ohm-1000 Ohm. In one embodiment, nerve ablation takes place by application of the following parameters: below 12 watts and 30 seconds-180 seconds.

Example 6

Proximal Renal Ablation

[0252] Using the above renal mapping approach that involves renal artery stimulation and changes in blood pressure and/or heart rate, it was found that stimulating proximal portion of renal artery in pig caused more signifi-

were compared within each group using a Fisher's least significant difference test. The blood pressure (BP) values between groups were compared at each time point with an unpaired t-test. Recently, Sakakura et al demonstrated the distribution of sympathetic peri-artery renal nerves in man and showed that the density of peri-artery renal sympathetic nerve fibers is lower in distal and dorsal locations but higher in proximal locations (J Am Coll Cardiol 2014; 64:635-643). These results provided anatomy basis for the use of this proximal ablation strategy in clinical practice.

TABLE 7

Full Length vs. Proximal Ablation Parameters			
	Full-length Group (n = 21)	Proximal Group (n = 19)	P value
Ablation No.			
LRA	6 ± 1	3	<0.001
RRA	7 ± 1	3.2 ± 0.2	<0.001
Mean RF time per site (s)	67 ± 4	69 ± 9	0.93
Total RF time (s)	906 ± 130	331 ± 32	<0.001
Power (W)	10 ± 2	11 ± 1	0.87
Temp (° C.)	40 ± 1	40 ± 1	0.91
Impedance (Ω)	188 ± 25	169 ± 11	0.047
Procedure time (min)	73 ± 8	45 ± 7	0.013

TABLE 8

Systolic and diastolic BPs at baseline and during 6 months of follow-up					
	Baseline	1 month	3 months	6 months	P value
Full-length					
Systolic BP	178.1 ± 13.5	147.7 ± 9.4	143.4 ± 7.0	140.4 ± 7.1	<0.001
Diastolic BP	101.7 ± 9.1	91.0 ± 6.0	85.3 ± 4.6	81.3 ± 3.6	<0.001
Proximal					
Systolic BP	179.8 ± 10.8	149.11 ± 8.6*	144.1 ± 7.6	140.3 ± 7.6	<0.001
Diastolic BP	103.3 ± 9.0	88.21 ± 6.3	84.5 ± 4.7	81.2 ± 4.7	<0.001

cantly increase in blood pressure as shown in FIG. 16. The effects of full renal artery ablation (n=21) (FIG. 17A) vs proximal renal artery ablation (n=19) (FIG. 17B) on arterial systolic and diastolic pressure were further compared in two groups of patients. Results, as shown in Table 7, revealed that by renal sympathetic mapping approach, and using full length renal artery ablation strategy, there were only 6 or 7 ablation sites needed for left renal artery and right renal artery, respectively. Once proximal renal sympathetic mapping approach was applied, the ablation sites were further decreased to approximately 3 for each side of the renal artery; meanwhile, total ablation time, procedure time and impedance were also significantly reduced compared to full length ablation strategy. These patients have been followed for 6 months to monitor their blood pressure. Comparable reductions in blood pressure have been achieved by significantly less renal ablations around proximal portion of renal artery (Table 8 and FIGS. 18A & 18B). The P values are for the results of repeated-measures ANOVA. Individual groups

[0253] In one embodiment, this invention provides a method for treatment of disease caused by systemic renal nerve hyperactivity by mapping and ablating only on the proximal portion of the renal artery. In one embodiment, the exact same site in the proximal portion of the renal artery is mapped and ablated. In another embodiment, ablation is conducted at one or more sites at the proximal portion of the renal artery while one or more separate sites in the renal artery is mapped and electrical stimulation delivered prior and after the ablation to verify whether ablation is successful.

[0254] In one embodiment, this invention provides a method where mapping is conducted at the distal portion of the renal artery to deliver electrical stimulation prior and after the ablation at the proximal portion of the renal artery to verify whether the ablation is successful. In one embodiment, electrical stimulation at mapped sites at the distal portion of renal artery does not elicit physiological after ablation at the proximal portion indicates that the ablation is successful.

[0255] In one embodiment, this invention provides a method for identifying responders to renal ablation by electrical stimulation at the proximal portion of the renal artery and observing for any physiological changes elicited.

[0256] This invention also provides a strategy for effective renal ablation. In one embodiment, the mapping and ablation procedure begin on the proximal portion of the renal artery and progress towards the distal portion until no response is observed when electrical stimulation is delivered. In one embodiment, one or more sites at the distal portion are mapped and ablation procedure will begin on the proximal portion of the renal artery and progress towards the distal portion until no response is observed when electrical stimulation is delivered at the one or more mapped sites at the distal portion of the renal artery.

[0257] In one embodiment, a first set of one or more electrodes is used for mapping one or more sites innervated with renal nerve at the distal portion of the renal artery such that electrical stimulation delivered at said one or more mapped locations will elicit changes in physiological parameters. A second set of electrodes will then carry out ablation at the proximal portion of the renal artery. In one embodiment, the ablation energy from the second set of electrodes is delivered to random locations at the proximal portion of the renal artery. In another embodiment, the electrodes from the second set of electrodes will also deliver electrical stimulation to map the renal nerve before ablation energy is delivered to the mapped locations. In a further embodiment, after the second set of electrodes has delivered the ablation energies, the first set of electrodes will deliver electrical stimulation at the mapped location at the distal portion of the renal artery to check if any changes in physiological parameters will be elicited so as to confirm the renal nerve has been interrupted by the ablation energy from the second set of electrodes.

Example 7

Renal Mapping Catheter Design

[0258] Based on the findings in this application, catheters with electrical stimulation and ablation functions are designed specifically for use in ablation of the proximal portion of renal artery.

[0259] In one embodiment, the distal end of the catheter can be designed to be any shapes whereby contact is made with the inner renal arterial wall at one or more locations within the proximal portion of the renal artery. In one embodiment, catheters with two, three, four, five, six, seven or eight electrodes can be designed in a spiral shape but only cover the proximal portion of the renal artery. In another embodiment, any of the catheters in Example 5 can be modified and adapted to contact only the proximal portion of the renal artery. In one embodiment, the catheter tip of the catheter is adapted to the renal artery having the typical diameter found in Asian populations. In one embodiment, the Asian population comprises the Chinese population. FIG. 19A shows the distribution of the length of left main renal artery in a Chinese population sample while FIG. 19B shows the distribution of the length of right main renal artery in the same sample. FIGS. 20 A to D shows respectively the distribution of the diameter of left renal artery measured at the ostium, $\frac{1}{3}$ of the length, $\frac{2}{3}$ of the length and at bifurcation in a Chinese population sample. FIGS. 20 E to H shows respectively the distribution of the diameter of right

renal artery measured at the ostium, $\frac{1}{3}$ of the length, $\frac{2}{3}$ of the length and at bifurcation in the same sample.

[0260] In one embodiment, the helical, spiral or other structures at the catheter tip of this invention has a diameter between 3.5 mm to 20 mm. In another embodiment, the catheter tip has a length between 2 mm-1.5 cm.

[0261] In one embodiment, the catheter tip comprises a spiral-shaped structure. In another embodiment, the catheter tip assumes a spiral shape upon activation. In one embodiment, the catheter tip comprises shape memory alloys or polymers which assume a spiral shape when heated or cooled to a specific transition temperature. In another embodiment, different parts of the catheter tip is made of shape memory alloys or polymers having different transition temperature so that the catheter tip can be activated to assume more than one configuration. In one embodiment, the spiral structure can be activated to assume different diameters based on the size of the renal artery. For example, the spiral structure can have diameters ranging from 3.5 mm to 20 mm. In one embodiment, the spiral-shaped structure comprises a resilient member that can assume a shape of a spiral pyramid. In another embodiment, the spiral-shaped structure comprises a one-loop spiral. FIG. 21A shows a catheter tip comprising a one-loop spiral-shaped structure 2100 having a plurality of electrodes 2101 in one embodiment of this invention. FIG. 21B shows the same catheter tip as view from the distal end. In one embodiment, the spiral structure forms a complete circle when viewed from the distal end. In another embodiment, the diameter of the spiral is selected from 3.5 mm to 20 mm. In a further embodiment, there are multi-loops in the spiral structure. For example, there can be one, 1.5 or two loops in the spiral structure. In one embodiment, there are multiple electrodes along the spiral structure. For example, there are 4, 5, 6 or 8 electrodes on the spiral structure.

[0262] In one embodiment, the spiral shape structure is a spiral pyramid as shown in FIGS. 21 C and D where the diameter of the distal loop is smaller than the more proximal loop. When a catheter tip is inserted into a renal artery, the second larger loop will be able to contact the arterial wall if the first loop is too small to do so. In one embodiment, the spiral structure comprises multiple loops with each loop decreasing in diameter from the distal end to the proximal end. In another embodiment, each smaller loop fits into the inner diameter of the larger loop so that all diameters in that range are covered.

[0263] In one embodiment, the catheter tip comprises an expanding structure. In one embodiment, the expanding structure can expand to a diameter between 3.5 mm to 20 mm. In one embodiment, the expanding structure comprises one or more resilient members pre-formed with a curvature which is attached to a controlling shaft at its proximal end and can be manipulated to move inside or outside of a tubular structure. Examples of expanding structure in different embodiments of this invention are shown in FIGS. 22A to C. FIG. 22A shows the resilient members 2200 being confined inside the tubular structure 2204. FIG. 22B shows the resilient members 2200 resuming their pre-formed curvature when pushed by the controlling shaft 2203 to move out of the tubular structure 2204. FIG. 22C shows a further embodiment of the present invention where a controlling ring 2205 is found at the proximal end of the resilient members 2200 and sleeves all resilient members 2200. The controlling ring 2205 can be independently pushed up or

down along the length of the resilient members **2200** so that the amount of expansion of the resilient members **2200** can be controlled.

[0264] In one embodiment, the distal ends of the one or more resilient members are attached to a controlling rod that can move independently of the controlling shaft. FIGS. **23A** to **C** shows an embodiment of this invention having this feature. As shown in FIG. **23B**, the resilient members **2300** do not resume their pre-formed curvature when pushed outside of the tubular structure because they are attached to the controlling rod **2305** at their distal ends. When the controlling rod **2305** is pulled backwards, the length of the controlling rod **2305** extended out of the controlling shaft is shorter than the resilient members **2300** and this will cause the resilient members to bulge as shown in FIG. **23C**. The more the controlling rod **2305** is pulled backwards, the more will the resilient members **2300** be bulging out. In other words, this will allow this catheter tip to adapt to renal arteries of different sizes.

[0265] In one embodiment, the resilient members of this invention comprises super elastic materials. In one embodiment, the super elastic material comprises shape memory alloys. In one embodiment, the shape memory alloys comprises nickel-titanium, or copper-zinc-aluminum. In another embodiment, the super elastic material comprises super elastic polymers.

[0266] In one embodiment, mapping and ablation of the renal artery is conducted with different portions of the same catheter as shown in FIG. **24**. In one embodiment, the catheter of this invention has two or more sets of electrodes comprising at least a first set of electrodes **2411** adapted to carry out mapping of renal nerve at the distal portion of the renal artery and a second set of electrodes **2421** adapted to carry out ablation at the proximal portion of the renal artery. In one embodiment, the first set of electrodes **2411** are located on an expandable catheter tip so that multiple sites on the distal portion of the renal artery could be contacted and electrical stimulation could be delivered to each of these sites singly or together. In another embodiment, the first set of electrodes **2411** comprises only one electrode for delivering electrical stimulation to a single site in the renal artery. In one embodiment, the first set of electrodes **2411** are located on a steerable catheter tip wherein the curvature of the catheter tip can be adjusted. In one embodiment, the distance between the first and second sets of electrodes can be adjusted. In one embodiment, the first set of electrodes is located on any one of catheter tips shown in FIGS. **3-7, 21-23**.

[0267] In one embodiment, the second set of electrodes **2421** are located on an expandable catheter tip so that multiple sites on the proximal portion of the renal artery could be contacted and ablation energy could be delivered to each of these sites singly or together. In another embodiment, the second set of electrodes **2421** comprises only one electrode for delivering ablation energy to a single site in the renal artery. In one embodiment, the second set of electrodes **2421** is located on any one of catheter tips shown in FIGS. **3-7, 21-23**.

[0268] In one embodiment, electrical stimulation and ablation of the renal nerve from within the renal artery is conducted with two separate catheters as shown in FIG. **25**. In one embodiment, a first catheter **2510** is inserted to the distal portion of a renal artery to deliver electrical stimulation. For example, the tip of the first catheter **2510** can be

one of those shown in FIGS. **3-7, 21-23**. In one embodiment, a second catheter **2520** is inserted to the proximal portion of a renal artery to deliver ablation energy. For example, the tip of the second catheter **2520** can be one of those shown in FIGS. **3-7, 21-23**.

[0269] FIG. **26** shows the physiological changes associated with using the catheter in FIG. **24** in one aspect of this invention for ablation of the renal artery. The catheter is first inserted into the renal artery such that the first set of electrodes is brought into contact with the inner wall of the distal portion of the renal artery at multiple sites and the second set of electrodes is brought into contact with the inner wall of the proximal portion of the renal artery as shown in FIG. **24**. Electrical stimulation is delivered from each of these electrodes to the site it contacts. If changes in physiological parameters as a result of the stimulation are observed (time point A), the second set of electrodes will deliver ablation energy to the proximal portion of the renal artery (time point B). If no changes in physiological parameters as a result of the stimulation are observed (time point O), the first set of electrodes will be manipulated such that each electrode contacts a new site and electrical stimulation will again be delivered to these new sites and this process will be repeated until changes in physiological parameters are observed in response to electrical stimulation (time point A). The length between the first set of electrodes and second set of electrodes can be adjusted so that both sets of electrodes can be placed at a location optimal for their functions in the renal artery. After the second set of electrodes delivered ablation energy (time point B), the first set of electrodes which maintained their contact with the multiple sites on the wall of the renal artery will deliver electrical stimulation to check that the renal nerve has been ablated. In case there is still physiological changes in response to electrical stimulation (time point C), ablation energy will be delivered at the same sites to fully ablate the renal nerve (time point D). Complete nerve ablation could be validated by further electrical stimulation from the first set of electrodes with no resulting physiological changes (time point E). Optionally, even if the first set of electrodes confirmed that the renal nerve has been ablated, these electrodes are manipulated to contact new locations in the renal artery and electrical stimulation delivered to ensure that there are no alternate pathways in the renal nerve that was not ablated by the second set of electrodes (time point F).

[0270] In one embodiment, there are multiple electrodes on the first set of electrodes that are randomly inserted to the distal portion of the renal artery. Since there are multiple electrodes, the chance of having one or more electrodes contacting a site innervated by renal nerve is high and electrical stimulation energy could be delivered without pinpointing which electrode(s) is(are) eliciting the physiological changes. In another embodiment, there are multiple electrodes on the second set of electrodes that are randomly inserted to the proximal portion of the renal artery. Since there are multiple electrodes in the second set of electrodes, the chance of having one or more of these electrodes contacting a site innervated by renal nerve is high and ablation energy could be delivered without pinpointing whether the electrode(s) is(are) contacting a site innervated with renal nerve. In one embodiment, the second set of electrodes is arranged in a helical manner so that a conventional helical ablation pattern could be completed easily. In

another embodiment, the electrodes are located on an expandable catheter tip such as those in FIGS. 5 and 6 so that the electrodes can be adjusted to contact the inner wall of renal artery of different sizes. In another embodiment, the second set of electrodes comprises only one electrode on a steerable catheter tip as shown in FIG. 7 and FIG. 24; a helical ablation pattern can be completed in the conventional manner with this set up. In another embodiment, the second set of electrodes comprising only one electrode also delivers electrical stimulation and ablation energy will only be delivered to specific sites where physiological changes are elicited by the electrical stimulation from the same electrode. Electrical stimulations from the first set of electrodes prior to and after the ablation will serve to confirm whether the ablation at the proximal portion of the renal artery is sufficient to achieve the desired effect.

[0271] In one embodiment, a second set of electrode having multiple electrodes is programmed to deliver ablation energy beginning from the electrode at the proximal portion of the renal artery and progress towards those electrodes at the distal portion of the renal artery, whereas electrical stimulation is delivered by a first set of electrode at one or more mapped sites at the distal portion of the renal artery both before and after each delivery of ablation energy. In another embodiment, delivery of ablation energy will be automatically stopped once electrical stimulation energy from the first set of electrodes no longer elicits changes in physiological parameters. In yet another embodiment, electrical stimulation from the first set of electrodes is delivered only before and after all electrodes in the second set of electrodes had delivered ablation energy. If physiological changes are still observed, the second set of electrodes will be manipulated such that each electrode contacts a new site on the proximal portion of the renal artery for ablation and this process will continue until electrical stimulation energy from the first set of electrodes no longer elicits changes in physiological parameters.

[0272] In one embodiment, the catheter having a first set of electrode for the distal portion of renal artery and a second set of electrodes for the proximal portion of the renal artery can be used in the system shown in FIG. 1.

Example 8

Identifying Renal Ablation Responders

[0273] The proper candidates for renal sympathetic denervation therapy can be selected via detection of certain blood neural hormone levels. However, catecholamine including epinephrine, norepinephrine and dopamine are not specifically coordinated with the tone of sympathetic nerve system because the levels of catecholamine are influenced by many other factors. For instance, it has been shown that plasma norepinephrine is increased with age (Ziegler M G et al: Plasma noradrenaline increases with age. *Nature* 1976, 261:333), smoking (Cryer P E et al: Norepinephrine and epinephrine release and adrenergic mediation of smoking associated hemodynamic and metabolic events. *N Engl J Med* 1976, 295:573), caffeine (Robertson D et al: Effects of caffeine on plasma renin activity, catecholamines and blood pressure. *N Engl J Med* 1978, 298:181), physical activity (Planz G et al: Correlation between increased dopamine- β -hydroxylase activity and catecholamine concentration in plasma: Determination of acute changes in sympathetic activity in man. *Eur J Clin Pharmacol* 1975, 8:181) and

sodium restriction (Robertson D et al: Salt restriction increases serum catecholamines and urinary normetanephrine excretion. *Fed Proc* 1977, 36:956). Levels of metanephrine and normetanephrine in plasma and urine reflect the activation of sympathetic nervous system, thus, further imply levels of sympathetic tone (Robertson D et al, *Hypertension* 1979, 1:118-124) because both metanephrine and normetanephrine are less influenced by other factors. However, accurate assessments of metanephrine and normetanephrine in urine cannot be done by regular laboratory methods. In order to measure urine metanephrine and normetanephrine during sympathetic activation, Robertson et al used sodium deprivation diet and exercise to activate the sympathetic system, then used isotope ratio method employing gas chromatography-mass spectrometry to measure urine metanephrine and normetanephrine, and radioenzymatic method to measure plasma epinephrine and norepinephrine. These investigators collected urine and blood samples in a 24-hour period from normal subjects and "borderline" hypertensive subjects who had normal blood pressure interspersed between hypertensive level. It was found that both sodium deprivation and exercise evoked increases in levels of plasma norepinephrine and urine normetanephrine in both normal and borderline hypertensive subjects, but in the borderline hypertensive group, these responses were exaggerated as indicated by significantly higher plasma norepinephrine and urine normetanephrine levels compared to normal subjects. Recently, more sensitive and specific methods have been developed to measure free O-methylated metabolites of catecholamine in plasma and urine, metanephrine and normetanephrine, for the purpose of diagnosing Pheochromocytomas and paragangliomas, for example, liquid chromatography with tandem mass spectrometry (LC-MS/MS) (Lagerstedt S A: *Clinical Chemistry* 2014, 50:3603-611; Gabler et al., *J Chromatograph Separat Techniq* 2012, 4:7; Marrington R et al: *Ann Clin Biochem* 2010; 47:467-475; Peitzsch M: *Clinica Chimica Acta* 2013, 418:50-58). Although these investigators all used LC-MS/MS to measure metanephrine and normetanephrine, however, their methods were different. For instance, Lagerstedt et al. had to use Oasis HLB for solid phase extraction (SPE) to enhance the sensitivity and specificity of their approach. Because Lagerstedt et al did not chromatographically separate epinephrine, thus their method has interference from epinephrine once its level was above 10.0 nmol/L in plasma. In order to further increase the sensitivity and eliminate this interference, Gabler et al separated normetanephrine from epinephrine chromatographically. Marrington group and Peitzsch group believed that measurements of metanephrine and normetanephrine in urine using LC-MS/MS are superior to using blood samples, because "the higher concentrations of the urinary than plasma metabolites make their measurements simpler and more readily and widely available" (Peitzsch M: *Clinica Chimica Acta* 2013: 418, 50-58). Marrington et al measured both total urinary metanephrine and total urinary normetanephrine including free and conjugated forms. Peitzsch et al believed that levels of free forms of metanephrine and normetanephrine in urine reflects the productions of these two hormones within adrenal chromaffin and pheochromocytoma tumor cells. Their approach allowed urinary catecholamines and their free and deconjugated O-methylated metabolites to be measured down to levels of 1.2 nmol/L. All these studies demonstrated the use of LC-MS/MS to mea-

sure metanephrine and normetanephrine for diagnosis of Pheochromocytomas and paragangliomas. The relationship between levels of normetanephrine and sympathetic nerve tone in primary hypertension patients has been predicted by Foti et al (Foti et al, The Relationships of Free to Conjugated Normetanephrine in Plasma and Spinal Fluid of Hypertensive Patients. *J Clin Endocrinol Metab* 1982, 55:81-85), who measured total and free normetanephrine in plasma by radioenzymatic assay. They found the mean concentrations of free normetanephrine in normotensives and hypertensives were 117 ± 10 and 155 ± 33 ng/liter, respectively; The mean concentrations of conjugated normetanephrine were 1417 ± 109 and 1670 ± 320 ng/liter in normotensives and primary hypertensives, respectively. The free and conjugated normetanephrine concentrations were 30% and 18% higher in patients with primary hypertension. Taken together, it is believed that using LC-MS/MS to measure metanephrine and normetanephrine in plasma and urine, in particular, the combinations of total and free format of these two hormones, can assess the tone of sympathetic nervous system and further select proper patient population for renal sympathetic denervation therapy.

[0274] In one embodiment, this invention provides a method to identify a subject with systemic renal nerve hyperactivity as a responder for treatment with renal modulation, comprising the steps of: obtaining a body fluid from said subject; measuring the amount of a metabolite in said body fluid with HPLC-MS, wherein said metabolite comprises one or more of free metanephrine, conjugated metanephrine, free normetanephrine and conjugated normetanephrine; comparing the level of said metabolite against a reference value; and identifying said subject as a responder if the level of said metabolite is higher than the reference value by a specific amount.

[0275] In one embodiment, the body fluid is blood or urine.

[0276] In one embodiment, the reference value is the concentration of the metabolite in a normal population. In one embodiment, the reference value for conjugated normetanephrine is 1417 ± 109 ng/liter. In another embodiment, the reference value for free normetanephrine is 117 ± 10 ng/liter.

[0277] In one embodiment, the measured amount is 30% higher than the reference value of free normetanephrine. In another embodiment, the measured amount is 18% higher than the reference value of conjugated normetanephrine.

[0278] In one embodiment, the baseline is obtained from a reference metabolite in the same body fluid.

[0279] In one embodiment, the above method of identifying a subject with systemic renal nerve hyperactivity as a responder for treatment with renal modulation is followed by the mapping and ablation procedures described in Examples 1 to 7 and other parts of this application.

[0280] As pointed out previously, patients with hypertension resistant to the available anti-hypertensive drugs were selected for renal ablation studies and this interventional procedure demonstrated a 89% clinical success rate in lowering their blood pressure. In this invention, it was demonstrated that electrical stimulation from the renal artery can elicit a physiological response in a subject and, therefore, is an indication whether renal nerve played a role in the hypertension. In one embodiment, the mapping method of this invention therefore serves as a method to identify responders to ablation.

[0281] In one embodiment, this invention provides a method for identifying patients responsive to renal ablation for treatment of disease caused by systemic renal nerve hyperactivity, comprising the steps of: a) introducing a catheter into the lumen of a renal artery of a patient such that a tip of the catheter contacts a site on the inner renal artery wall; b) measuring one or more physiological parameters to obtain baseline measurements before introducing an electrical current to the site, such physiological parameters include systolic blood pressure, diastolic blood pressure, mean arterial pressure, and/or heart rate; c) applying electrical stimulation by introducing an electrical current to the site via the catheter, wherein the electrical current is controlled to be sufficient to elicit an increase in the physiological parameters when there is an underlying nerve at the site; and d) measuring the above physiological parameters at a desired time interval after each electrical stimulation, wherein an increase of physiological parameters over the baseline measurements after electrical stimulation would indicate that the patient is responsive to renal ablation.

[0282] In one embodiment, the catheter is an ablative catheter designed to treat cardiac arrhythmias. In another embodiment, the catheter is an ablative catheter designed specifically for mapping renal nerves for ablative procedures.

[0283] In one embodiment, the desired time interval in step (d) is from about 5 seconds to about 2 minutes.

[0284] In one embodiment, the one or more physiological parameters include systolic blood pressure, and the increase in systolic blood pressure is in the range of 4 to 29 mmHg.

[0285] In one embodiment, the one or more physiological parameters include diastolic blood pressure, and the increase in diastolic blood pressure is in the range of 1.5 to 20 mmHg.

[0286] In one embodiment, the one or more physiological parameters include mean arterial pressure, and the increase in mean arterial pressure is in the range of 3 to 17 mmHg.

[0287] In one embodiment, the one or more physiological parameters include heart rate, and the increase in heart rate is in the range of 4 to 12 beats/min.

[0288] In one embodiment, the electrical current sufficient to elicit changes in the physiological parameters comprises one or more of the following parameters: a) voltage of between 2 and 30 volts; b) resistance of between 100 and 1000 ohms; c) current of between 5 and 40 miliamperes; d) applied between 0.1 and 20 milliseconds; and e) total applied time is between 1 to 5 minutes.

Example 9

Renal Ablation at Locations Other than Renal Artery

[0289] Renal artery stimulation results in respectively increases or decreases in systemic blood pressure/heart rate, thereby indicating the location of renal sympathetic and parasympathetic nerve innervations. Experimentally, it has been shown that electrical stimulation can be delivered from inside of renal artery. Since renal nerves travel around renal artery within vascular adventures, and renal veins are parallel with renal artery, thus electrical stimulation can be achieved via a renal vein approach (Madhavan et al: *J Cardiovasc Electrophysiol*, Vol. pp. 1-4) or from outside of renal artery, that is, direct renal nerve stimulation. Based on the study by Chinushi et al (*Hypertension* 2013; 61:450-456) which showed increase in blood pressure by stimulation of

renal nerves, Madhavan believed that increase in blood pressure can be achieved by transvenous stimulation of renal sympathetic nerves. Seven dogs and one baboon were used in their study. A catheter was placed in the vein of the animal and high-frequency stimulation (800-900 pps, 10 V, 30-200 seconds) was delivered. These investigators observed a significant increase in systolic blood pressure from 117 (± 28) to 128 (± 33) mmHg, and increase in diastolic blood pressure from 75 (± 19) to 87 (± 29) mmHg. That study confirmed previous findings of increases in blood pressure by stimulation of renal sympathetic nerves (Wang, US2011/0306851). However, the present investigators believe that the effects of renal sympathetic nerve stimulation on blood pressure can be utilized to treat hypotensive conditions such as neurocardiogenic syncope. Thus, the method of renal nerve stimulation described herein can be performed via intra-renal artery approach, extra-renal artery approach such as direct renal artery stimulation, or via intra-renal vein stimulation.

REFERENCES

- [0290] 1. Aars, H. and Akre, S., (1970), Reflex Changes in Sympathetic Activity and Arterial Blood Pressure Evoked by Afferent Stimulation of the Renal Nerve, *Acta Physiol. Scand.*, 78 (2): 184-188
- [0291] 2. Beacham, W. S. and Kunze, D. L., (1969), Renal Receptors Evoking a Spinal Vasomotor Reflex, *J. Physiol.*, 201 (1): 73-85
- [0292] 3. Campese, V. M., Kogosov, E., (April 1995), Renal afferent denervation prevents hypertension in rats with chronic renal failure, 25(4 Pt. 2): 878-882.
- [0293] 4. Campese, V. M., and Krol, E., (June 2002), Neurogenic factors in renal hypertension, *Current Hypertension Reports*, 4(3):256-260.
- [0294] 5. Converse, R. L. Jr., Jacobsen, T. N., Toto, R. D., Jost, C. M., Cosentino, F., Fouad-Tarazi, F., Victor, R. G., (December 1992) Sympathetic overactivity in patients with chronic renal failure, *New England Journal of Medicine*, 327(27):1912-1918.
- [0295] 6. Dibona, Gerald F. and Ulla C. Kopp, (January 1997), Neural Control of Renal Function, *Physiological Reviews*, 77(1): 75-197.
- [0296] 7. DiBona, G. F. (2003), Neural control of the kidney: past, present and future, *Hypertension*, 41: 621-624.
- [0297] 8. Esler, M., Jennings, G., Lambert, G., Meredith, I., Home, M., Eisenhofer, G., (October 1990) Overflow of catecholamine neurotransmitters to the circulation: source, fate, and functions, *Physiological Reviews*, 70(4): 963-985.
- [0298] 9. Esler, M., Schlaich, M., Sobotka, P. et al., (2009) Catheter-based renal denervation reduces total body and renal noradrenaline spillover and blood pressure in resistant hypertension, *Journal of Hypertension*, 27(suppl 4):s167.
- [0299] 10. Esler, M. et al., (Dec. 4, 2010), Renal sympathetic denervation in patients with treatment-resistant hypertension (The Symplicity HTN-2 Trial): a randomized controlled study, *The Lancet*, 376: 1903-1909.
- [0300] 11. Krum, H., Schlaich, M., Whitbourn, R., Sobotka, P. A., Sadowski, J., Krzysztow, Bartus, K., Kapelak, B., Walton, A., Sievert, H., Thambar, S., Abraham, W. T., and Esler, M., (April 2009), Catheter-based renal sympathetic denervation for resistant hypertension: a multicentre safety and proof-of-principle cohort study, *The Lancet*, 373(9671):1275-1281.
- [0301] 12. Lu, M., Wei, S. G. and Chai, X. S., (1995), Effect of Electrical Stimulation of Afferent Renal Nerve on Arterial Blood Pressure, Heart Rate and Vasopressin in Rabbits, *Acta Physiol. Sinica*, 47 (5): 471-477
- [0302] 13. Ma, G. and Ho, S. Y., (1990), Hemodynamic Effects of Renal Interoreceptor and Afferent Nerve Stimulation in Rabbit, *Acta Physiol. Sinica*, 42 (3): 262-268
- [0303] 14. Mahfoud, F., Schlaich, M., Kindermann, I., Ukena, C., Cremers, B., Brandt, M. C., Hoppe, U. C., Vonend, O., Rump, L. C., Sobotka, P. A., Krum, H., Esler, M., and Bohm, M., (May 10, 2011), Effect of Renal Sympathetic Denervation on Glucose Metabolism in Patients With Resistant Hypertension: A Pilot Study, *Circulation* 123(18): 1940-1946.
- [0304] 15. Medical devices: pg 1-2, Feb. 22, 2012
- [0305] 16. Schlaich, M. P., Sobotka, P. A., Krum, H., Lambert, E., and Esler, M. D., (Aug. 27, 2009), *New England Journal of Medicine*, 36(9): 932-934.
- [0306] 17. Schlaich, M. P., Krum, H., Whitbourn, R. et al., (2009), A novel catheter based approach to denervate the human kidney reduces blood pressure and muscle sympathetic nerve activity in a patient with end stage renal disease and hypertension. *Journal of Hypertension*, 27(suppl 4):s154.
- [0307] 18. Smithwick, R. H., and Thompson, J. E., (Aug. 15, 1953), Splanchnicectomy for essential hypertension; results in 1,266 cases. *J Am Med Association*, 152(16): 1501-1504.
- [0308] 19. Talenfeld, A. D., Schwoppe, R. B., Alper, H. J., Cohen, E. I., and Lookstein, R. A., (June 2007), MDCT Angiography of the Renal Arteries in Patients with Atherosclerotic Renal Artery Stenosis: Implications for Renal Artery Stenting with Distal Projection, *American Journal of Roentgenology*, 188: 1652-1658.
- [0309] 20. Ueda, H., Uchida, Y., and Kamisaka, K., (1967), Mechanism of the Reflex Depressor Effect by Kidney in Dog, *Jpn. Heart J.*, 8 (6): 597-606
- [0310] 21. Valente, J. F., Dreyer, D. R., Breda, M. A., Bennett, W. M., (January 2001), Laparoscopic renal denervation for intractable ADPKD-related pain. *Nephrology Dialysis Transplantation*, 16(1): 160.
- [0311] 22. Vigilance D. W., Mutrie C. J., Yi G. H., Yu K., Guo A., Gelfand M., Smith C. R., Oz M. C., Levin H., Wang J., (2005), A novel approach to increase total urine output in acute heart failure: unilateral renal nerve blockade. *Journal of the American College of Cardiology Supplement* 2005, 45(3):166A.
- [0312] 23. Wang, J., Mapping sympathetic nerve distribution for renal ablation and catheters for the same, U S patent application no. 2011/0306851 A1, filed Aug. 26, 2011.
- [0313] 24. Ye, S., Zhong, H., Yanamadala, V., Campese, V. M., (August 2002), Renal injury caused by intrarenal injection of phenol increases afferent and efferent sympathetic nerve activity, *American Journal of Hypertension*, 15(8): 717-724.
- [0314] 25. Ziegler M G et al: Plasma noradrenaline increases with age. *Nature* 1976, 261: 333
- [0315] 26. Cryer P E et al: Norepinephrine and epinephrine release and adrenergic mediation of smoking associated hemodynamic and metabolic events. *N Engl J Med* 1976, 295: 573

- [0316] 27. Robertson D et al: Effects of caffeine on plasma renin activity, catecholamines and blood pressure. *N Engl J Med* 1978, 298:181
- [0317] 28. Planz G et al: Correlation between increased dopamine- β -hydroxylase activity and catecholamine concentration in plasma: Determination of acute changes in sympathetic activity in man. *Eur J Clin Pharmacol* 1975, 8: 181
- [0318] 29. Robertson D et al: Salt restriction increases serum catecholamines and urinary normetanephrine excretion. *Fed Proc* 1977, 36: 956
- [0319] 30. Robertson D et al, *Hypertension* 1979, 1: 118-124
- [0320] 31. Lagerstedt S A: *Clinical Chemistry* 2014, 50:3603-611
- [0321] 32. Gabler et al., *J Chromatograph Separat Techniq* 2012, 4:7
- [0322] 33. Marrington R et al: *Ann Clin Biochem* 2010; 47:467-475
- [0323] 34. Peitzsch M: *Clinica Chimica Acta* 2013: 418, 50-58
- [0324] 35. Foti et al, The Relationships of Free to Conjugated Normetanephrine in Plasma and Spinal Fluid of Hypertensive Patients. *J Clin Endocrinol Metab* 1982, 55: 81-85
- [0325] 36. MADHAVAN et al: *J Cardiovasc Electrophysiol*, Vol. pp. 1-4
- [0326] 37. Chinushi et al (*Hypertension* 2013; 61: 450-456.
- 1-20. (canceled)
21. A method for generating a map of innervated areas in a renal artery, said method comprises the steps of:
- introducing a catheter into said renal artery such that the tip of said catheter contacts a site on an inner wall of said renal artery;
 - measuring one or more physiological parameters to obtain baseline measurements before introducing an electrical current to the site, said physiological parameters are selected from the group consisting of systolic blood pressure, diastolic blood pressure, mean arterial pressure, and heart rate;
 - applying an electrical stimulation by introducing an electrical current to the site via the catheter, wherein said electrical current is controlled to be sufficient to elicit changes in said physiological parameters when there is an underlying nerve at the site; and
 - measuring said physiological parameters at a specific time interval after the electrical stimulation, wherein an increase of said physiological parameters over the baseline measurements after said electrical stimulation indicates that a sympathetic renal nerve has been mapped at said site, wherein a decrease of said physiological parameters over the baseline measurements after said electrical stimulation indicates that a parasympathetic renal nerve has been mapped at said site;
 - repeating steps (a) to (d), thereby obtaining a map of innervated areas in said renal artery.
22. The method of claim 21, wherein said map is further correlated with 3D structure data of said renal artery to obtain a 3D map of innervated areas in said renal artery.
23. The method of claim 22, wherein said 3D structure data is obtained using tomographic imaging techniques.
24. The method of claim 23, wherein said tomographic imaging technique is magnetic resonance imaging, computed tomography or ultrasound.
25. The method of claim 21, wherein said steps (a) to (d) are conducted under live imaging techniques.
26. The method of claim 25, wherein said live imaging techniques is X-ray or ultrasound.
27. The method of claim 21, wherein the electrical current delivered falls within the following ranges:
- voltage of between 2 and 30 volts;
 - resistance of between 100 and 1000 ohms;
 - current of between 5 and 40 milliamperes;
 - time of application between 0.1 and 20 milliseconds.
28. The method of claim 21, wherein said increase in systolic blood pressure ranges from 4 to 29 mmHg.
29. The method of claim 21, wherein said increase in diastolic blood pressure ranges from 1.5 to 20 mmHg.
30. The method of claim 21, wherein said increase in mean arterial pressure ranges from 3 to 17 mmHg.
31. The method of claim 21, wherein said increase in heart rate ranges from 4 to 12 beats/min.
32. A map of innervated areas in a renal artery, said map is generated by the method of claim 21.
33. A method of using the map of claim 32 in renal ablation, comprising the step of displaying said map to a physician during renal ablation.
34. A system for generating a map of innervated areas in a renal artery, comprising:
- a catheter configured to deliver an electrical current to one or more locations on an inner wall of a renal artery sufficient to stimulate a nerve innervating said locations;
 - one or more measuring devices for measuring one or more physiological parameters associated with innervation of said renal artery, wherein said physiological parameters are selected from the group consisting of systolic blood pressure, diastolic blood pressure, mean arterial pressure, and heart rate;
 - a computing device coupled to said one or more measuring devices and is configured for computing any increase or decrease in the physiological parameters against a baseline, said computing device is also configured to receive and correlate 3D structure data of said renal artery; and
 - a display device for displaying the location or identity of a parasympathetic or sympathetic nerve innervating said renal artery.
35. The system of claim 34, wherein said catheter could also deliver ablative energy selected from the group consisting of radiofrequency, mechanical, ultrasonic, radiation, optical and thermal energies.
36. The system of claim 34, wherein said computing device comprises one or more microcontrollers or computers.
37. The system of claim 34, further comprising a tomographic imaging system.
38. The system of claim 37, wherein said tomographic imaging system is magnetic resonance imaging, computed tomography or ultrasound.
39. The system of claim 34, further comprising a live imaging system.
40. The system of claim 39, wherein said live imaging system is X-ray or ultrasound.

专利名称(译)	用于绘制支配动脉壁的功能性神经的系统和方法，3-d映射和用于其的导管		
公开(公告)号	US20180078307A1	公开(公告)日	2018-03-22
申请号	US15/802610	申请日	2013-08-23
[标]申请(专利权)人(译)	SYMAP医疗苏州		
[标]发明人	WANG JIE		
发明人	WANG, JIE		
IPC分类号	A61B18/14 A61B5/0215 A61B5/024 A61B5/04 A61B5/20 A61B5/0205 A61B5/00 A61B18/00 A61B18/18 A61N1/36		
CPC分类号	A61B2018/00791 A61B2018/00839 A61B2018/00511 A61B2018/0022 A61B2018/00267 A61B5/0215 A61B5/4836 A61B5/024 A61B5/04001 A61B5/6853 A61B18/18 A61N1/36117 A61B5/4893 A61B5/4833 A61B5/201 A61B2018/00875 A61B2018/1407 A61B2018/1435 A61B18/1492 A61B2018/00202 A61B2018/1475 A61B2018/00404 A61B2018/00577 A61B2018/00434 A61B5/0205 A61B5/0036		
优先权	201310070820.3 2013-03-06 CN 14/241061 2014-02-25 US 15/691768 2017-08-31 US 14/421869 2015-02-16 US 61/609565 2012-03-12 US 61/527893 2011-08-26 US 61/693019 2012-08-24 US		
外部链接	Espacenet USPTO		

摘要(译)

本文公开了用于定位和识别支配诸如肾动脉的动脉壁的神经的系统和方法。本发明识别血管壁上由神经支配的区域;提供了关于能量是否被准确地递送到目标神经的指示;并且提供对神经传递能量的效果的立即程序后评估。该方法包括在将能量输送到动脉壁之后评估生理参数的变化;并基于评估结果确定能量被引导至的神经的类型(交感神经或副交感神经或无)。该系统至少包括用于将能量输送到血管壁的装置;用于检测来自对象的生理信号的传感器;以及显示使用所述方法获得的结果的指示器。还提供用于执行绘图和消融功能的导管。

