



US 20170196713A1

(19) **United States**

(12) **Patent Application Publication**  
**Gross et al.**

(10) **Pub. No.: US 2017/0196713 A1**  
(43) **Pub. Date: Jul. 13, 2017**

(54) **DEVICES AND METHODS FOR CONTROL OF BLOOD PRESSURE**

**Publication Classification**

(71) Applicant: **Vascular Dynamics, Inc.**, Mountain View, CA (US)

(51) **Int. Cl.**  
*A61F 2/82* (2006.01)  
*A61B 5/00* (2006.01)  
*A61F 2/90* (2006.01)  
*A61B 5/0215* (2006.01)  
*A61F 2/856* (2006.01)

(72) Inventors: **Yossi Gross**, Moshav Mazor (IL); **Itzik Avneri**, Tel Aviv (IL); **Ori Weisberg**, Shdema (IL); **Moshe Eshkol**, Harutzim (IL); **Tal Oren**, Ra'anana (IL); **Yaron Assaf**, Maagan-Michael (IL); **Tanhum Feld**, Moshav Merhavva (IL); **Moshe Elazar**, Azor (IL)

(52) **U.S. Cl.**  
CPC ..... *A61F 2/82* (2013.01); *A61B 5/0215* (2013.01); *A61F 2/856* (2013.01); *A61F 2/90* (2013.01); *A61B 5/0053* (2013.01); *A61F 2230/0069* (2013.01)

(21) Appl. No.: **15/473,116**

(57) **ABSTRACT**

(22) Filed: **Mar. 29, 2017**

Apparatus and methods are described including an implantable device having first and second longitudinal ends, the device having a length of less than 80 mm when the device is unconstrained. The device includes struts arranged such that, when the device is unconstrained, along a continuous portion of the device having a length that is at least 5 mm, a maximum inter-strut distance defined by any set of two adjacent struts is more than 1.5 times as great as a maximum inter-strut distance defined by any set of two adjacent struts within longitudinal portions of the device within 3 mm of the longitudinal ends of the device. Other applications are also described.

**Related U.S. Application Data**

(60) Division of application No. 13/455,005, filed on Apr. 24, 2012, now Pat. No. 9,642,726, which is a continuation-in-part of application No. 13/030,384, filed on Feb. 18, 2011, now Pat. No. 9,125,732, which is a continuation-in-part of application No. 12/774,254, filed on May 5, 2010, now abandoned.

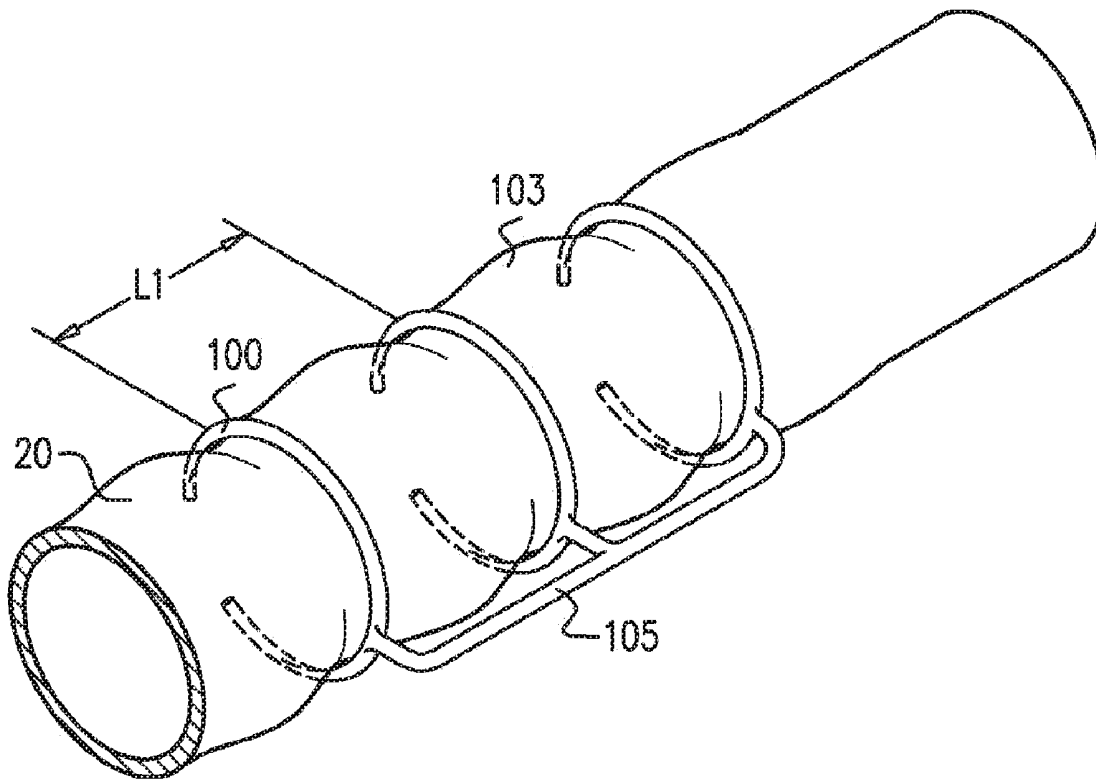

FIG. 1  
PRIOR ART

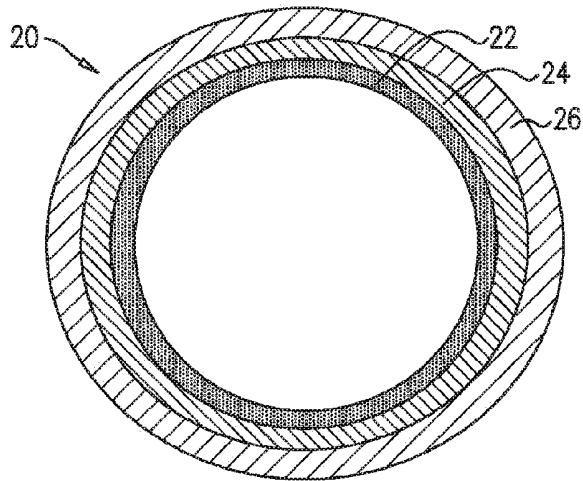

FIG. 2A

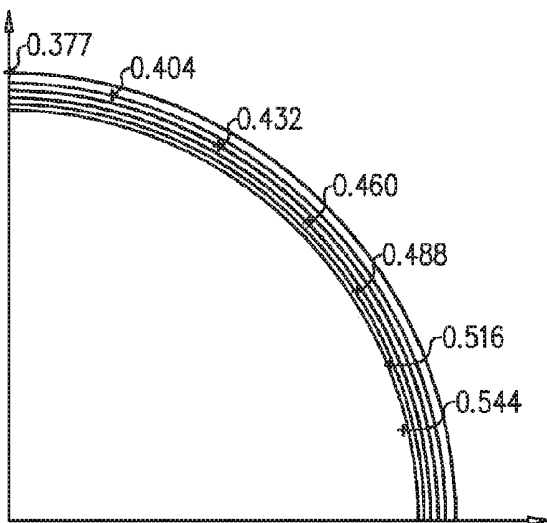

FIG. 2B

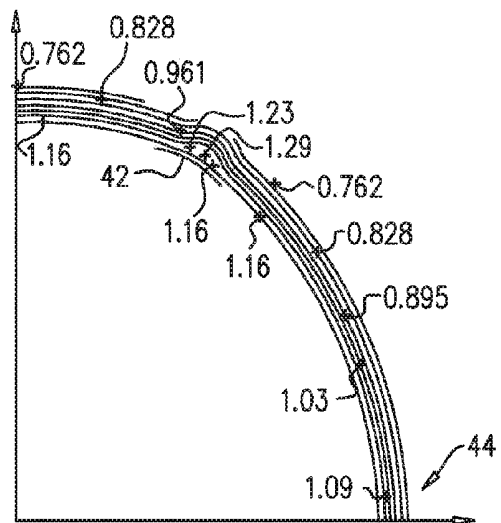
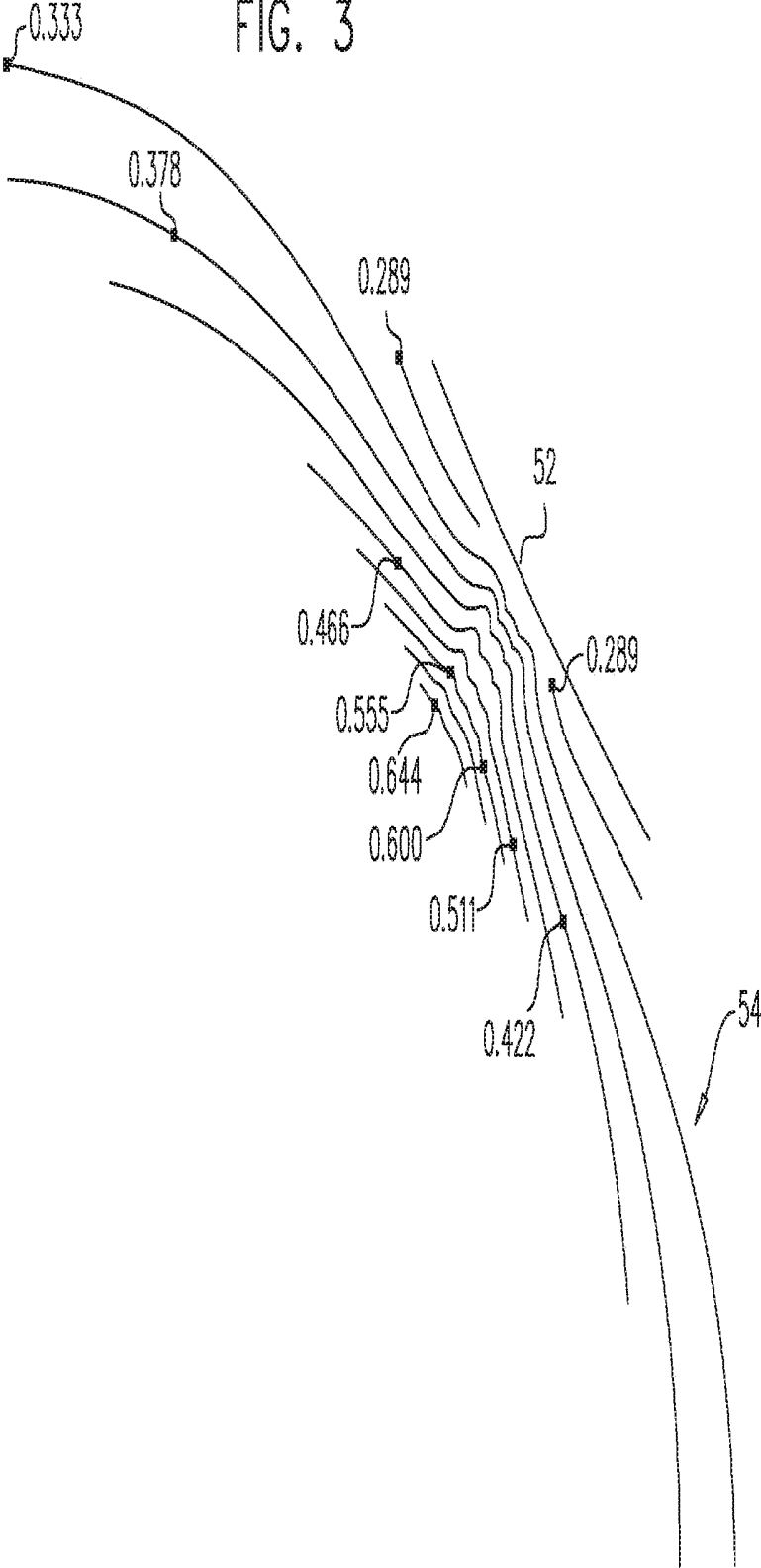

FIG. 3



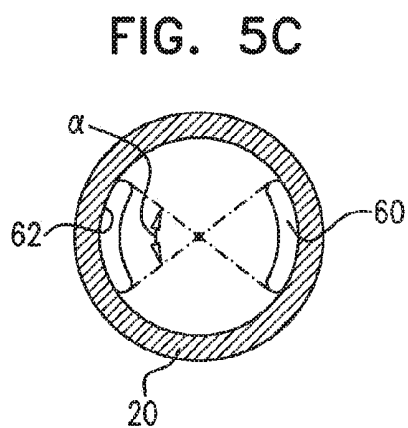
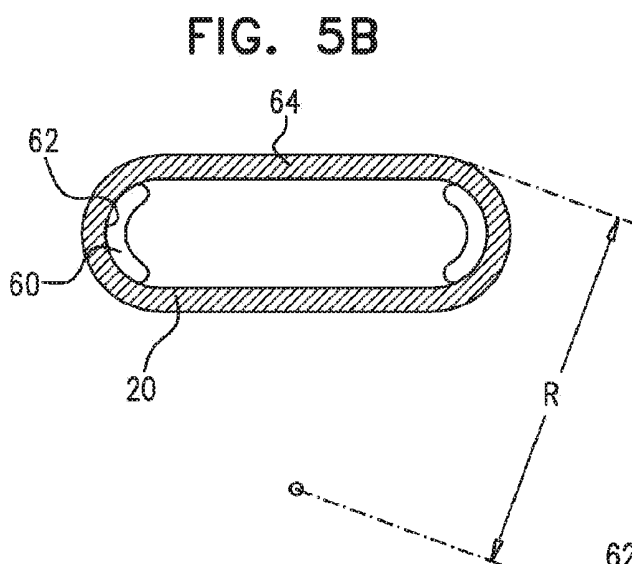
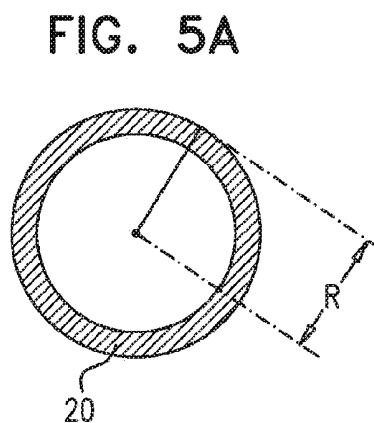
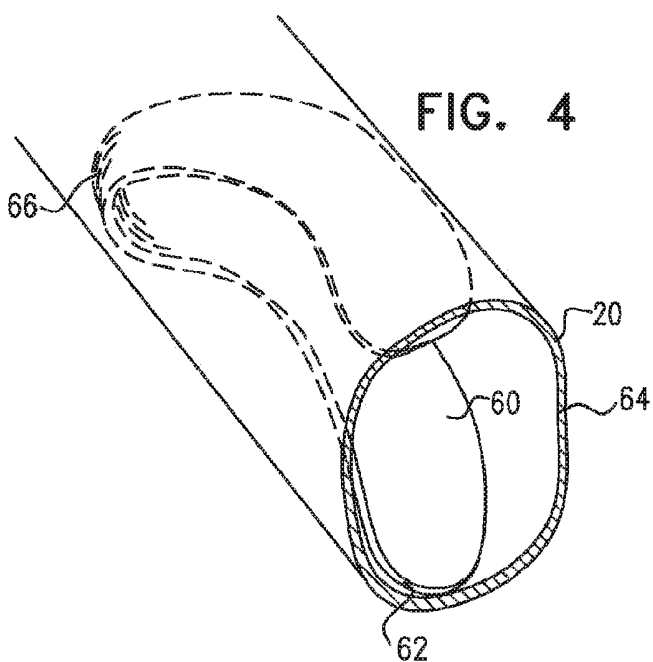

FIG. 6A

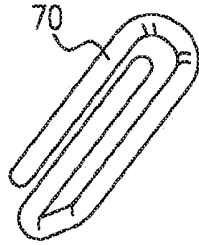

FIG. 6B

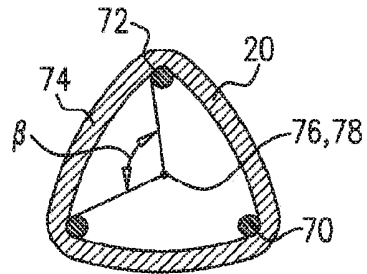

FIG. 7A

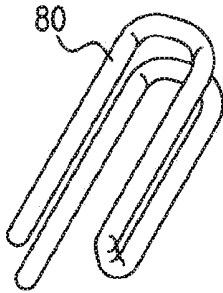

FIG. 7B

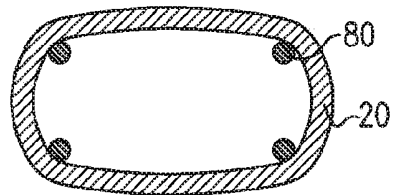

FIG. 8A

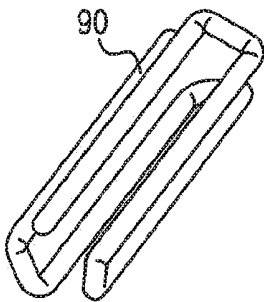

FIG. 8B

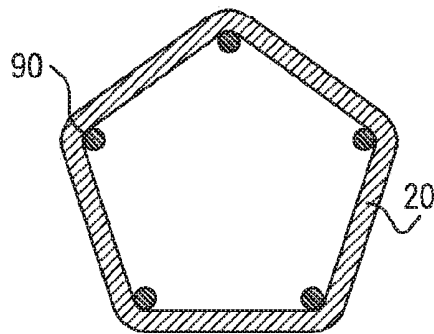

FIG. 9A

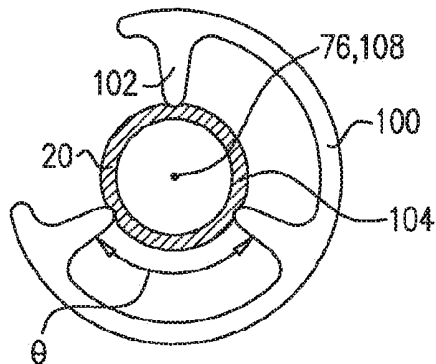

FIG. 9B

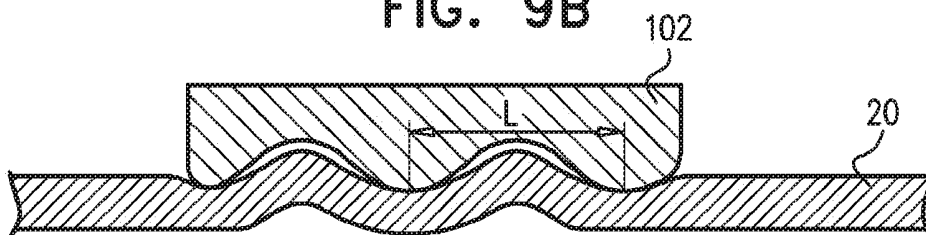

FIG. 9C

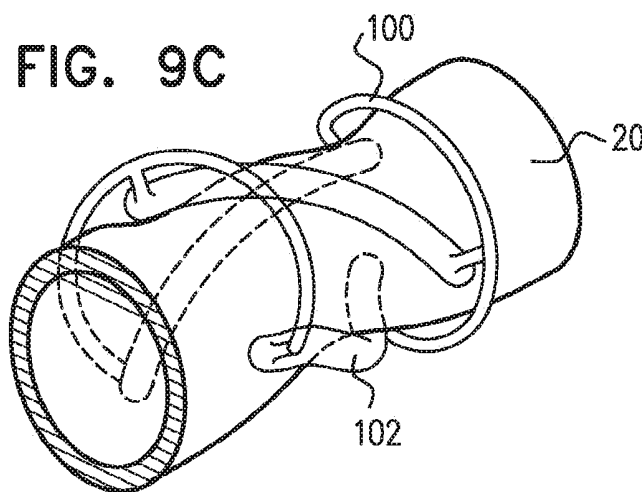

FIG. 9D

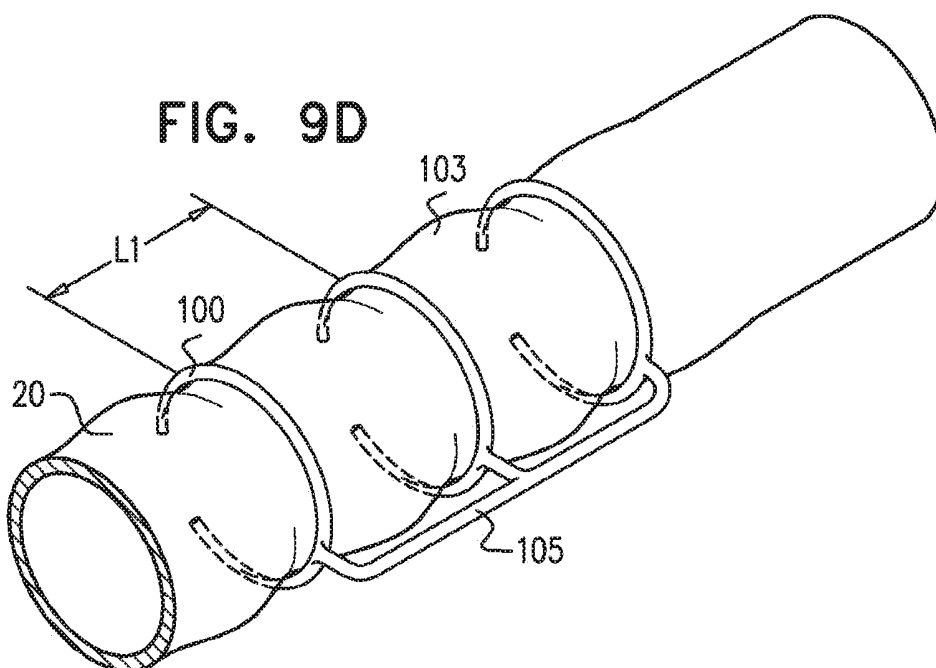

FIG. 10

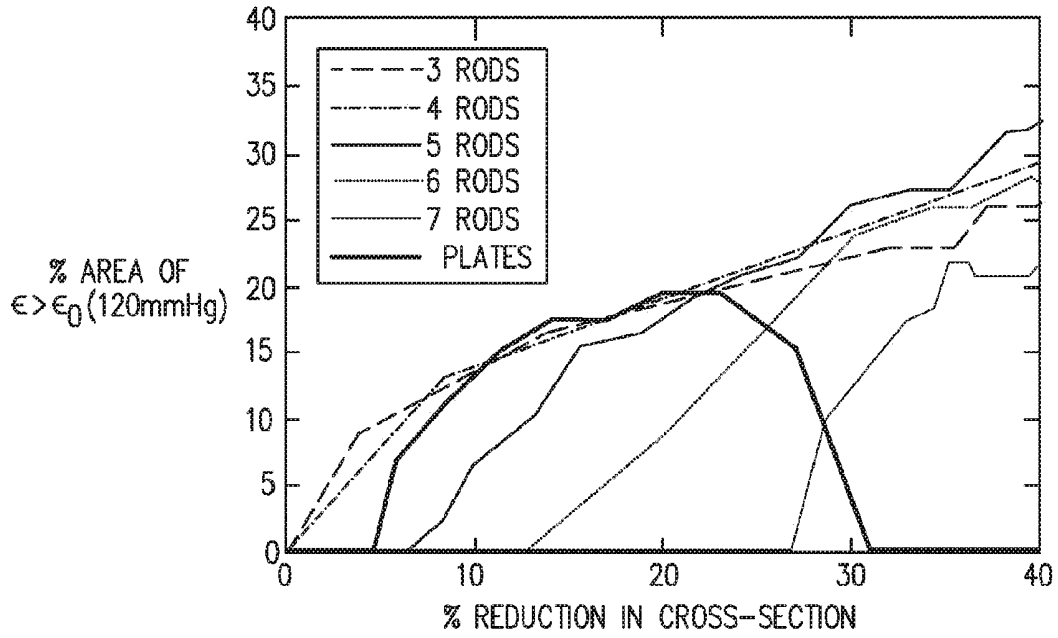

FIG. 11

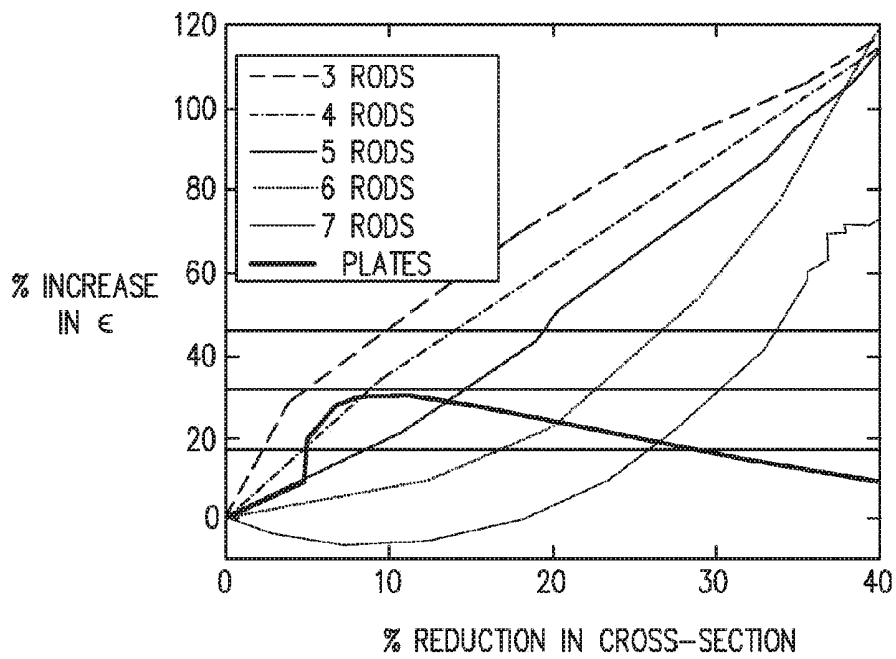

FIG. 12

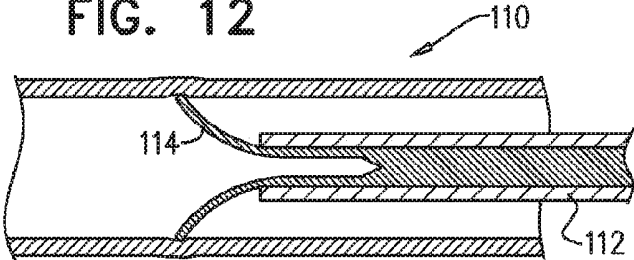

FIG. 13

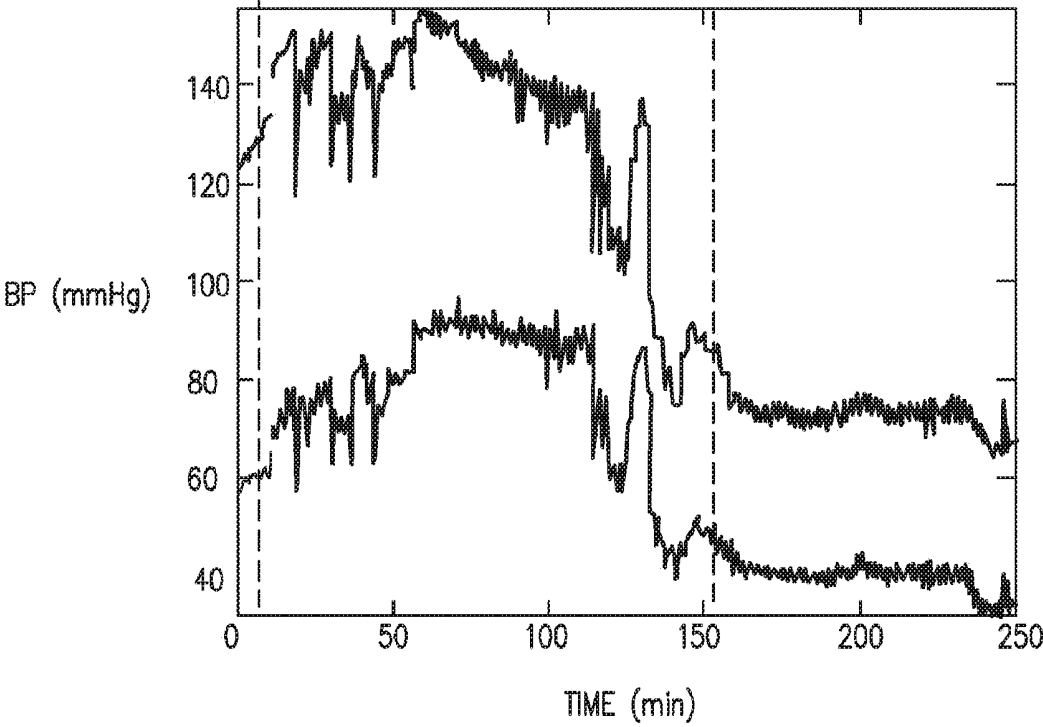

FIG. 14

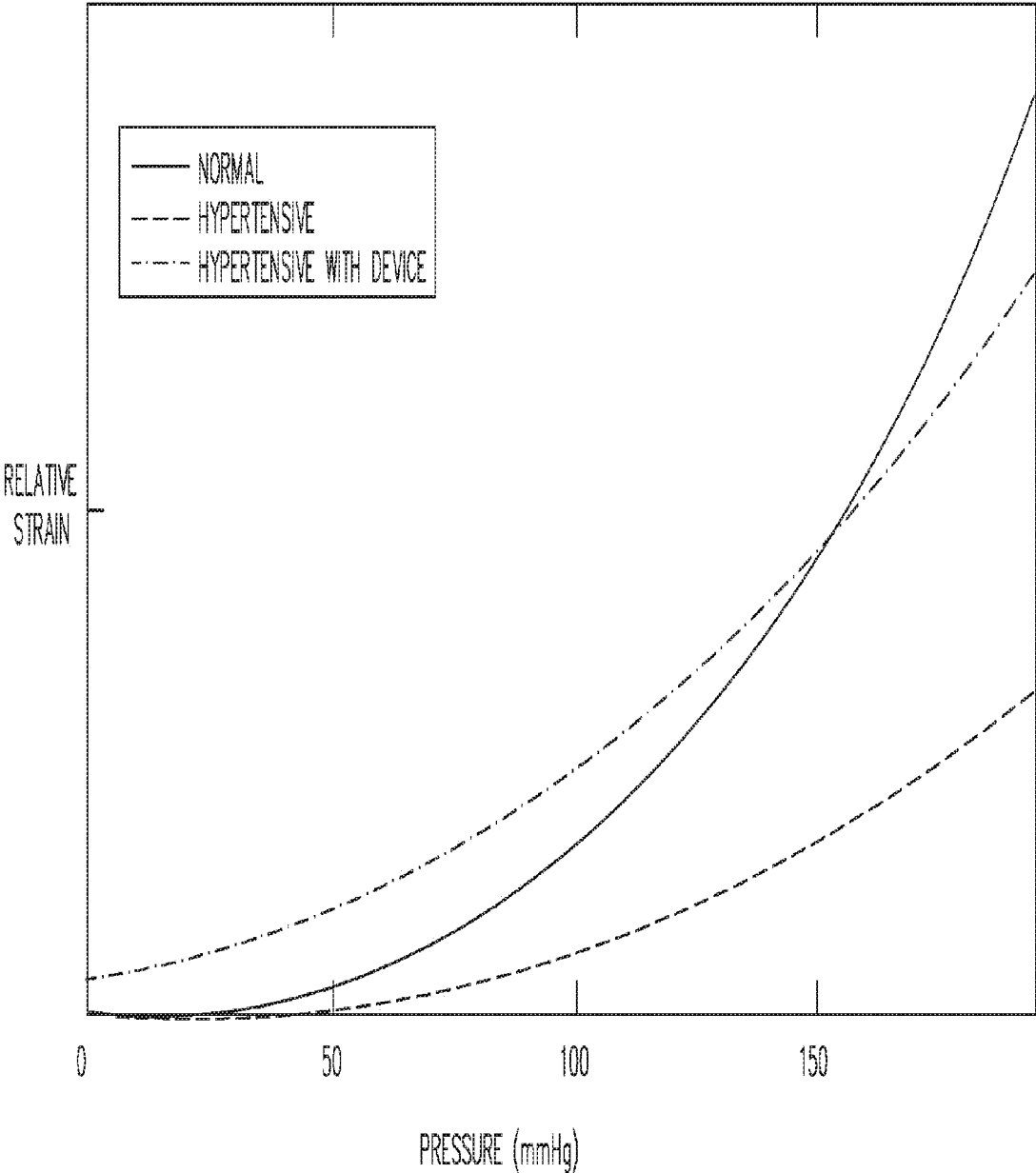

FIG. 15A

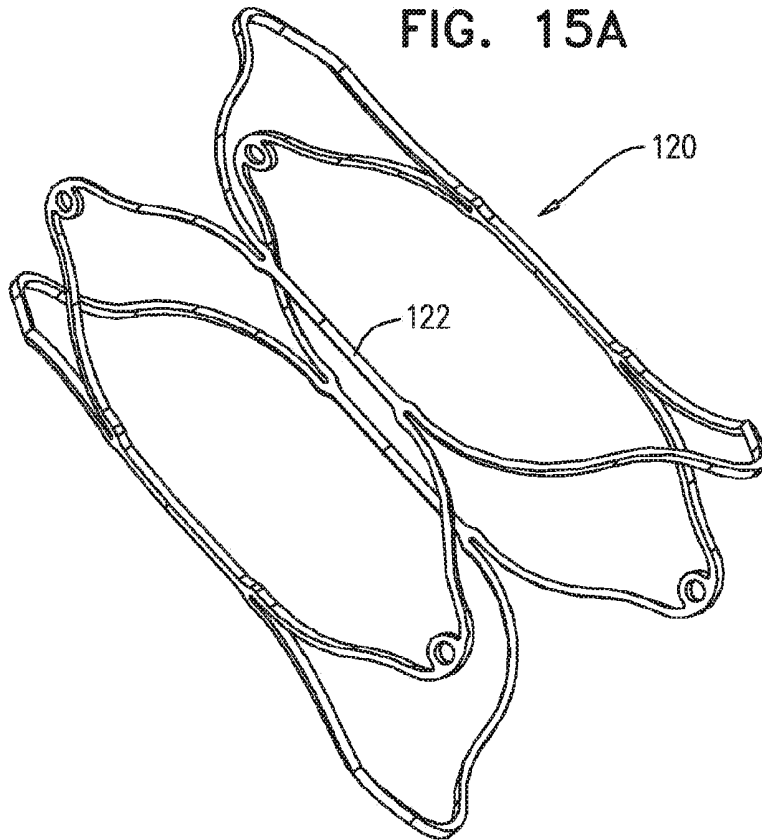
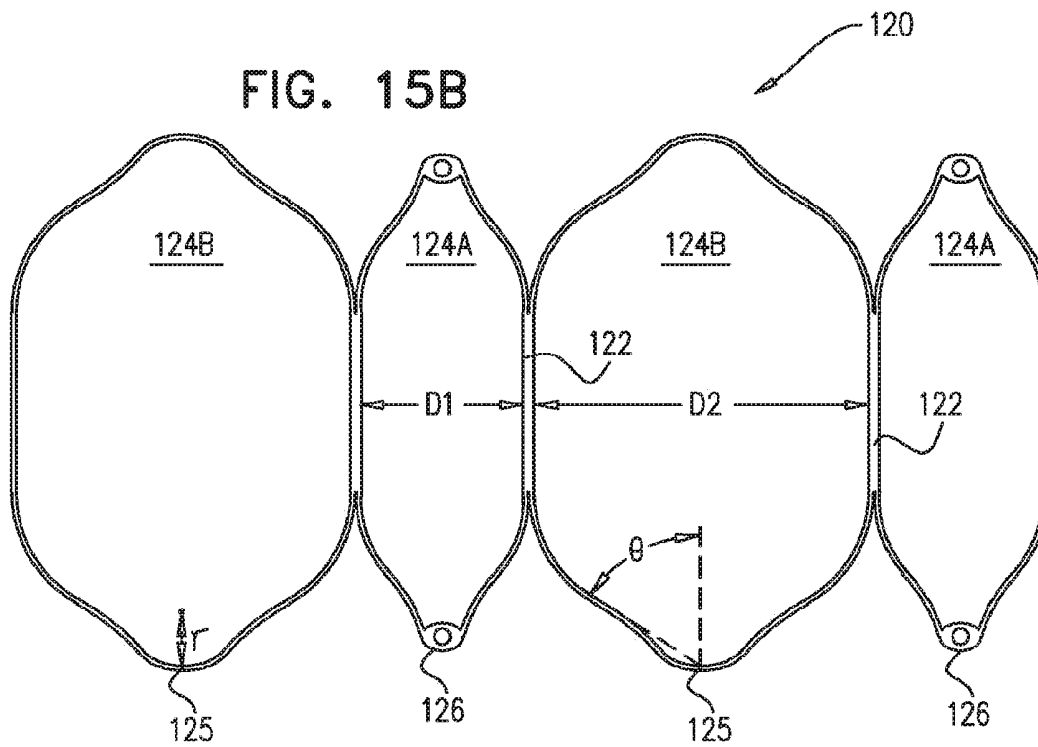

FIG. 15B



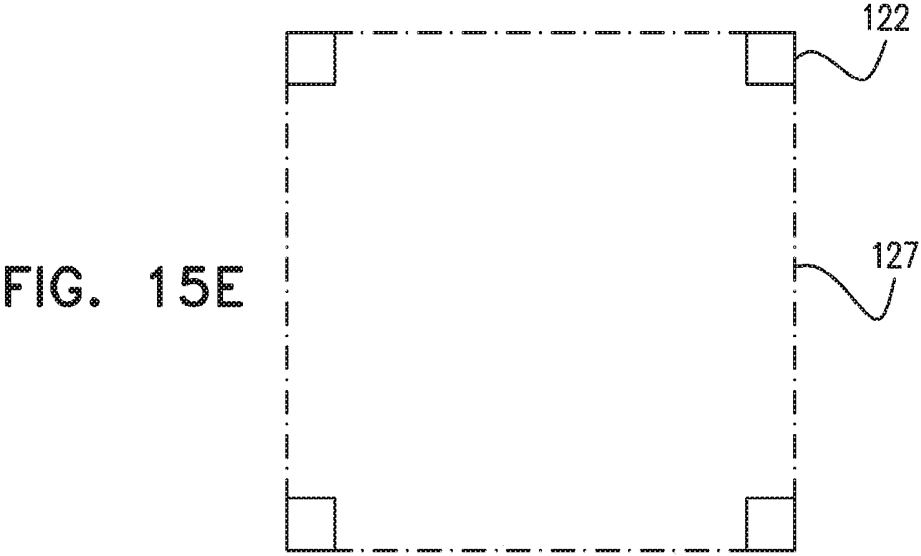
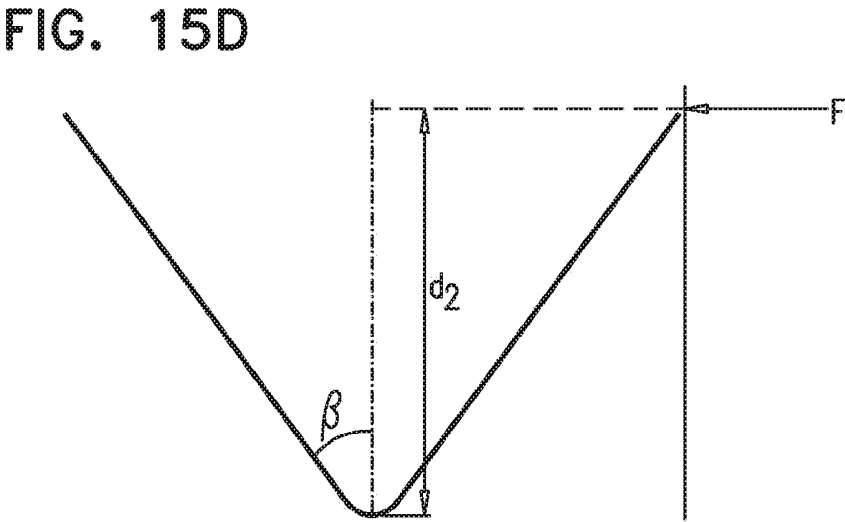
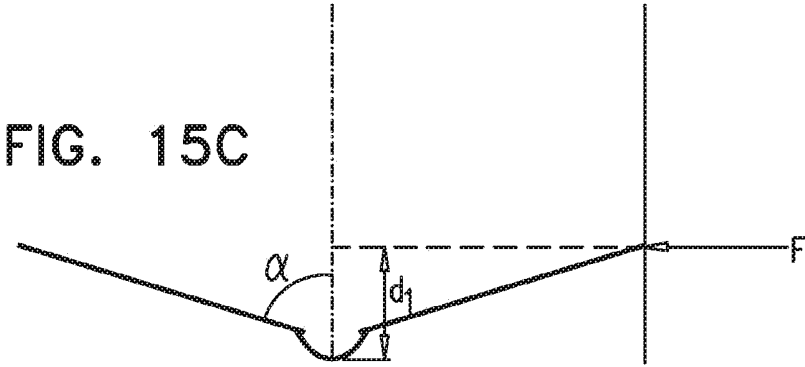

FIG. 16A

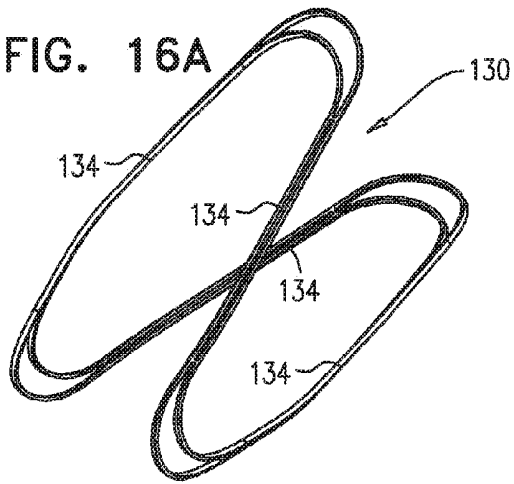

FIG. 16B

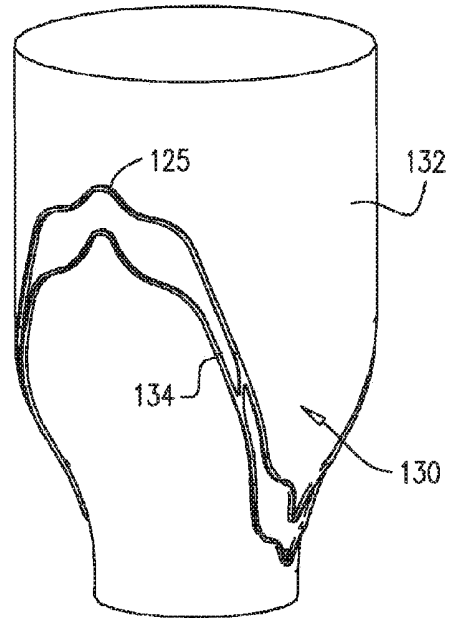

FIG. 16C

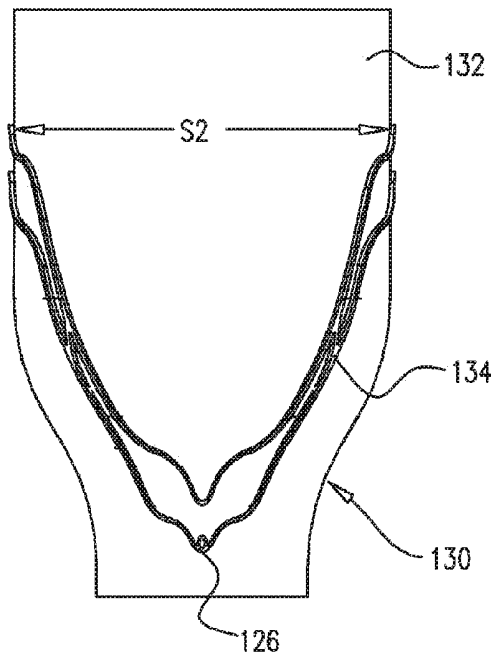

FIG. 16D

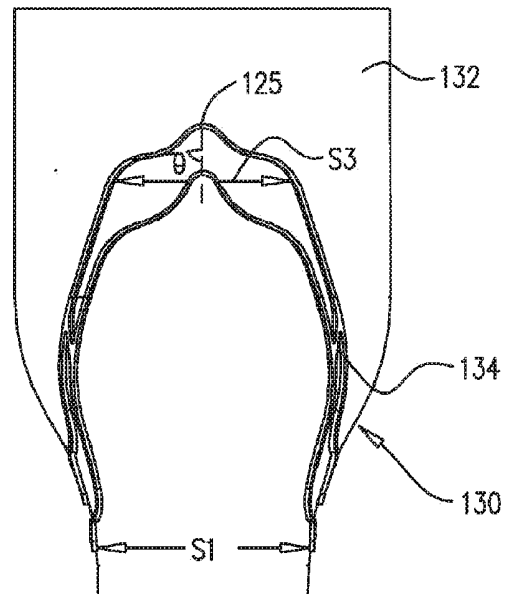

FIG. 17A

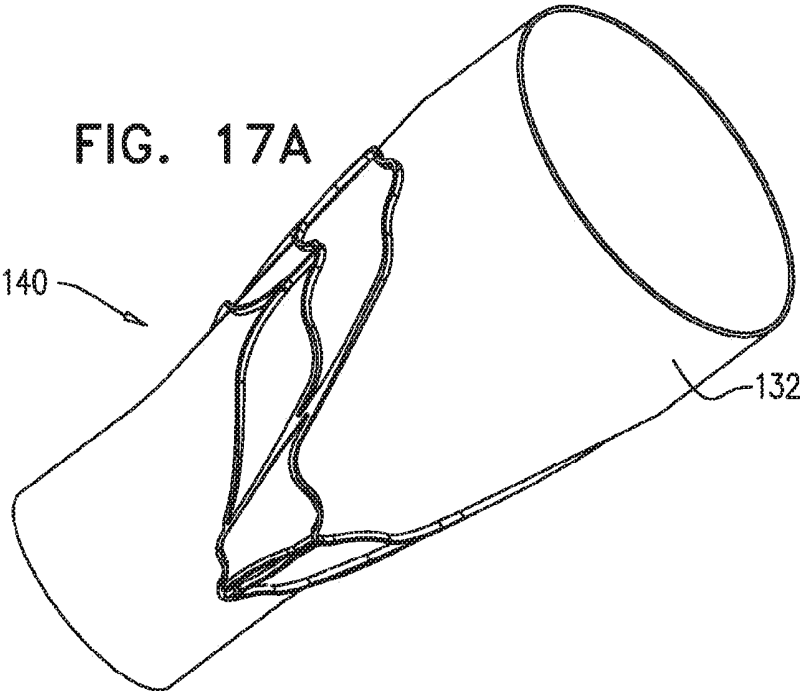

FIG. 17B

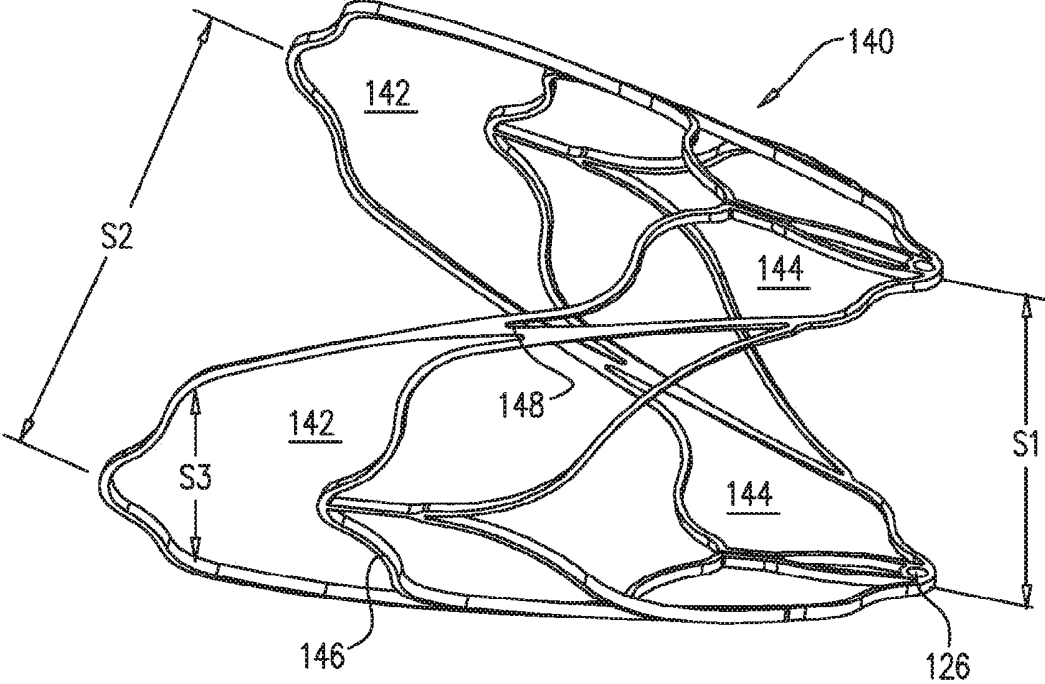

FIG. 17C

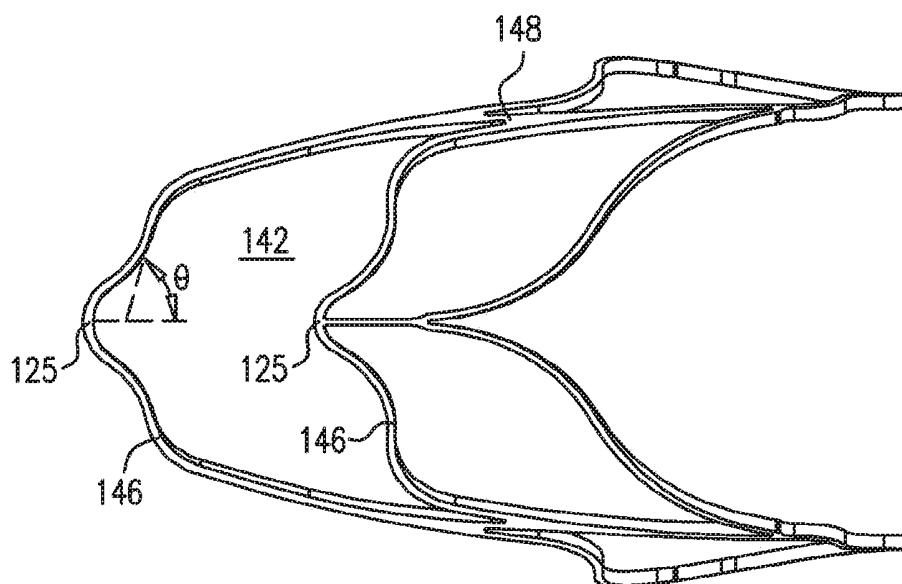

FIG. 17D

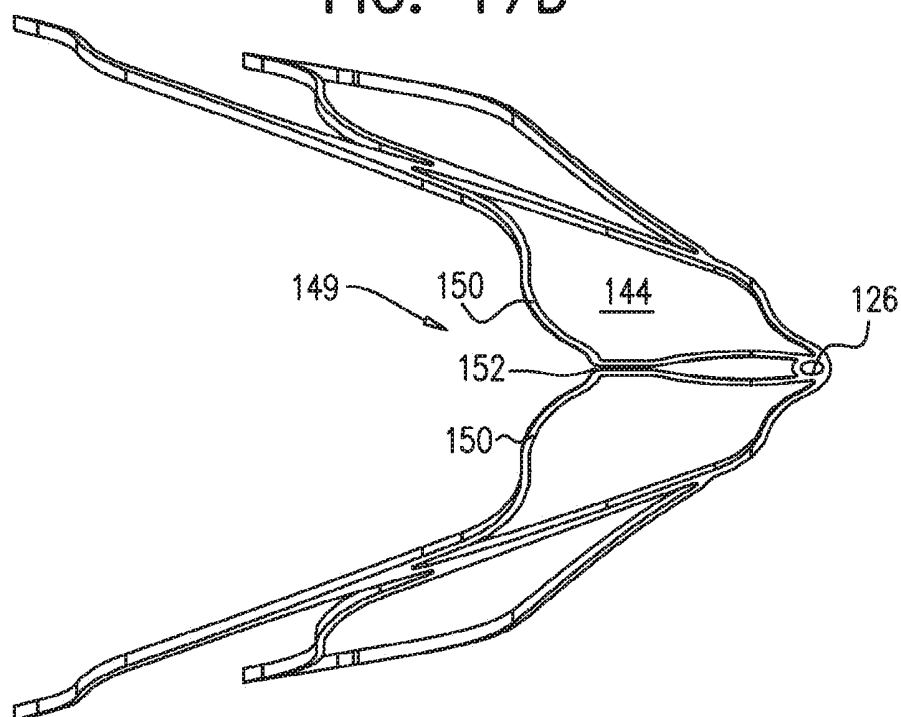

FIG. 18A

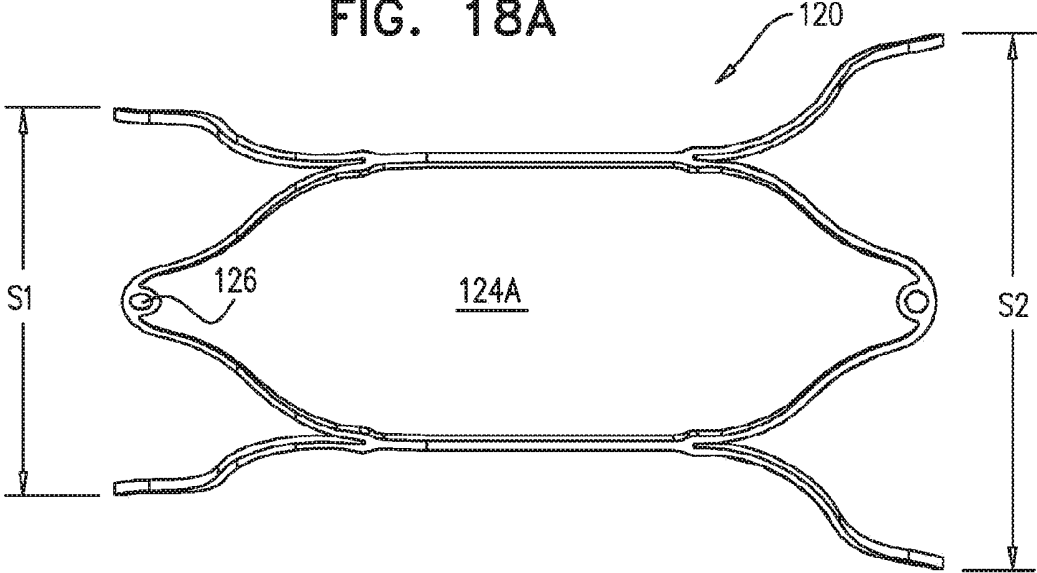

FIG. 18B

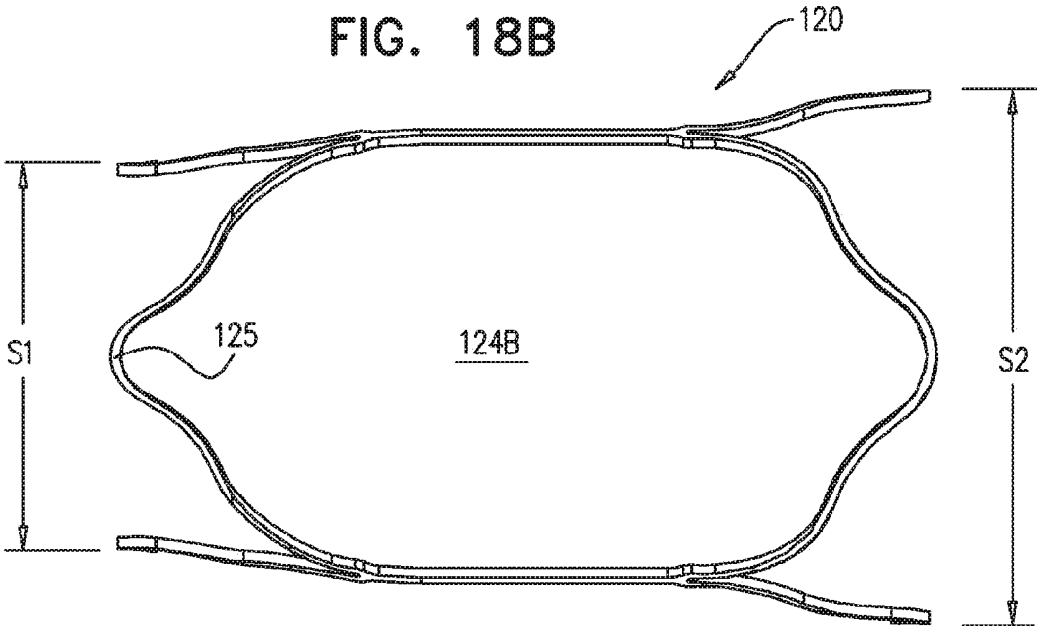

FIG. 18C

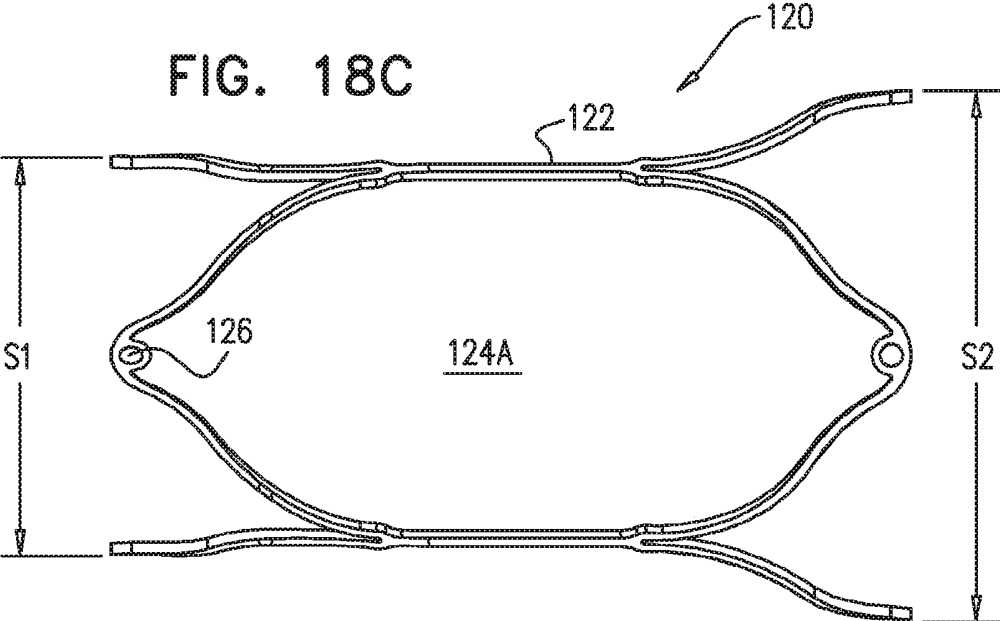
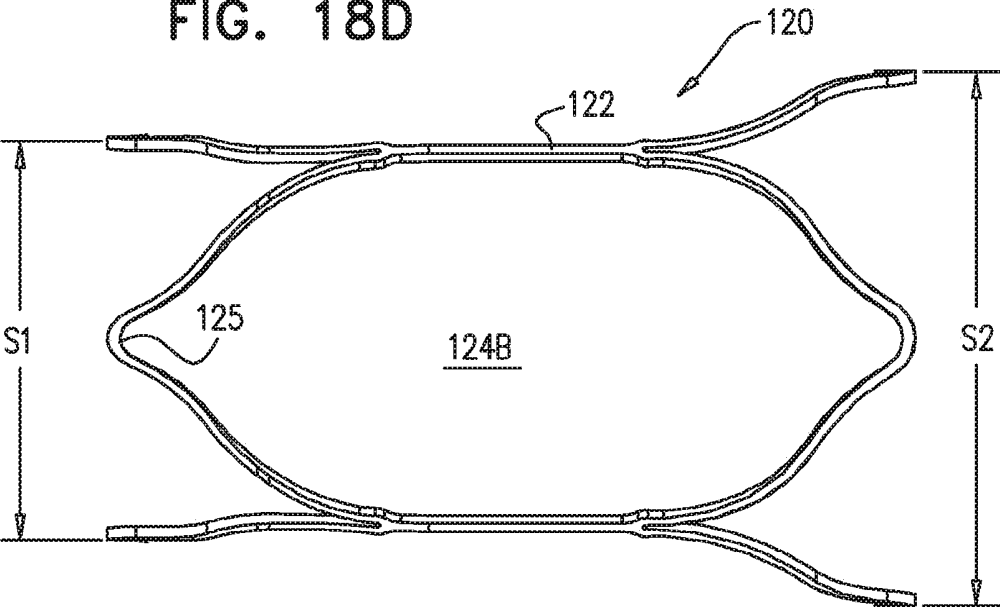

FIG. 18D



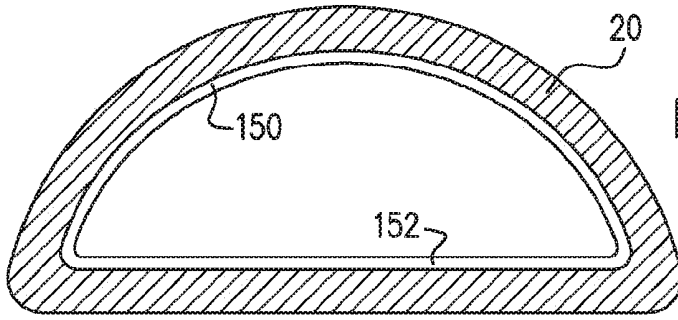

FIG. 19

FIG. 20

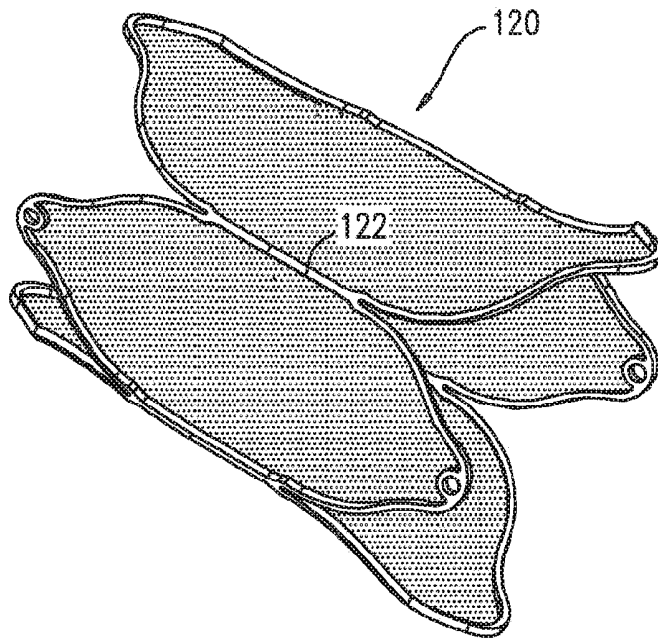

FIG. 21

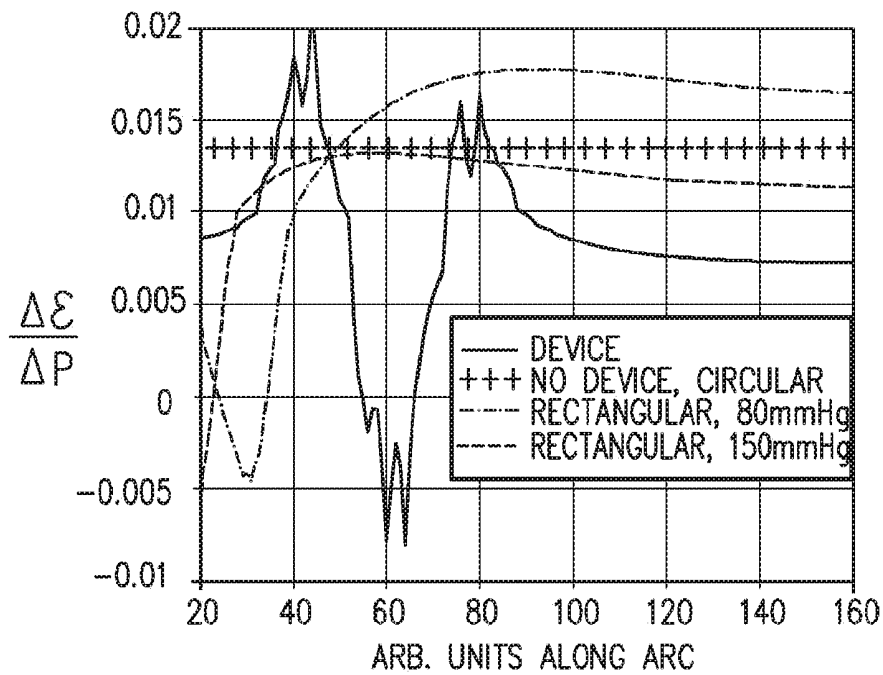

FIG. 22A

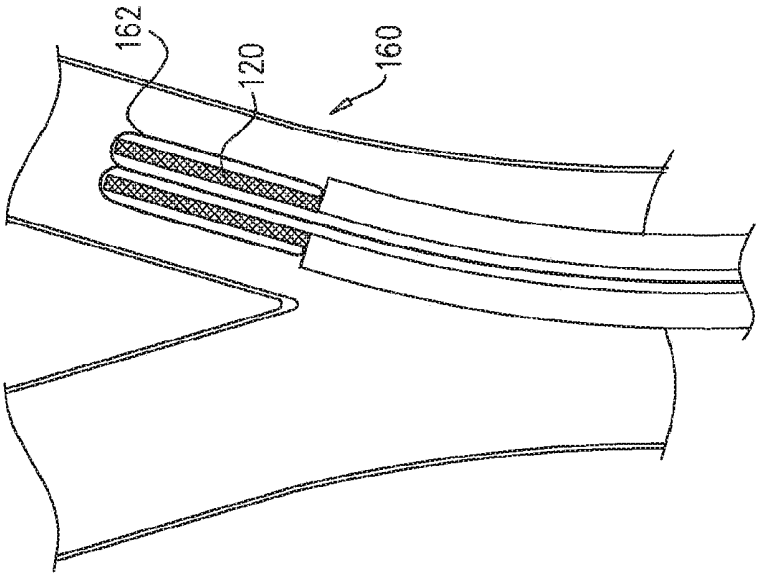

FIG. 22B

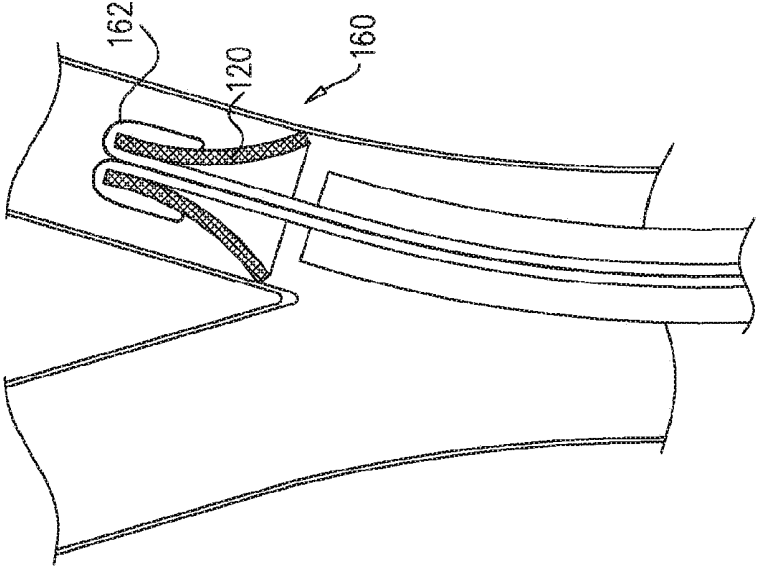
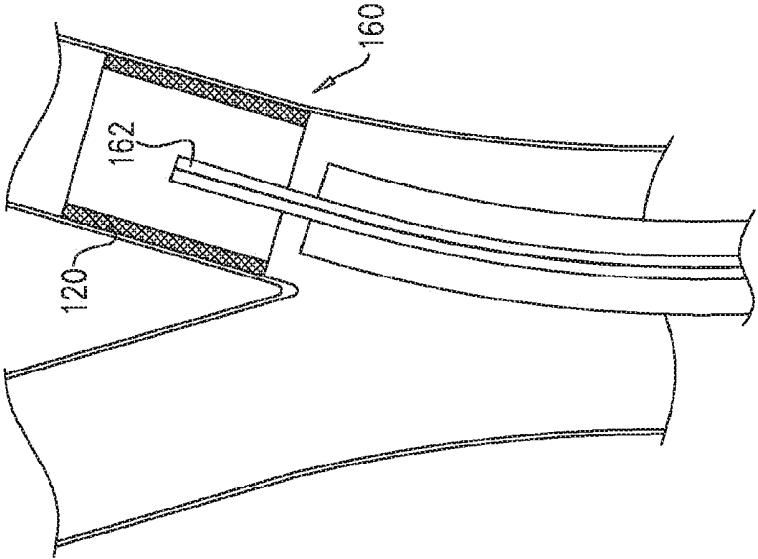

FIG. 22C



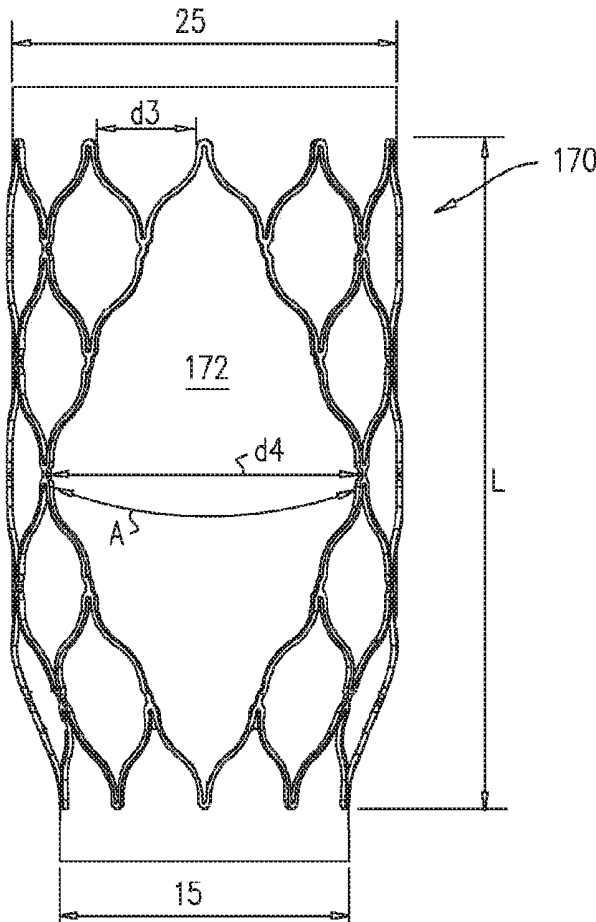

FIG. 23A

FIG. 23B

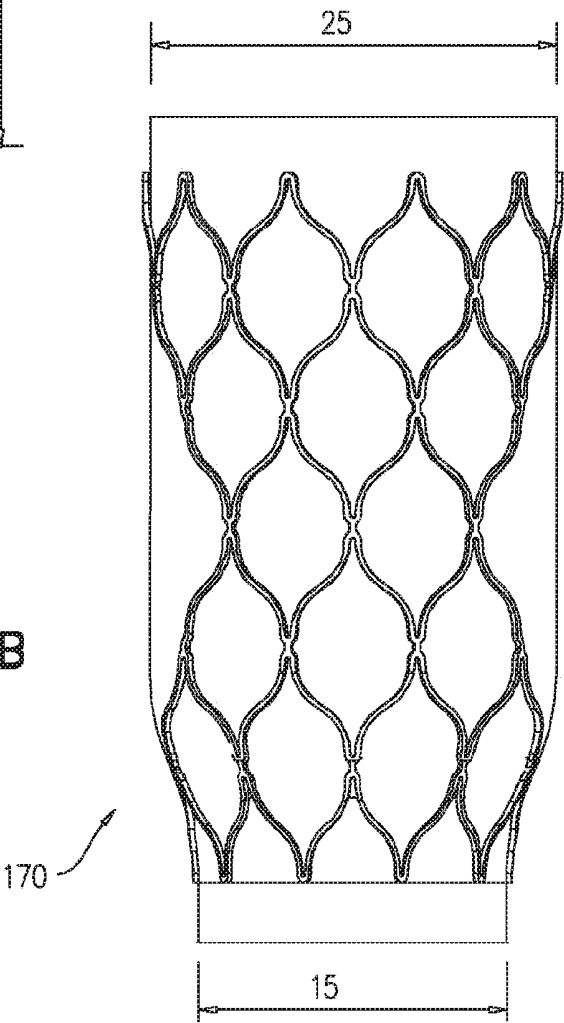

FIG. 24A

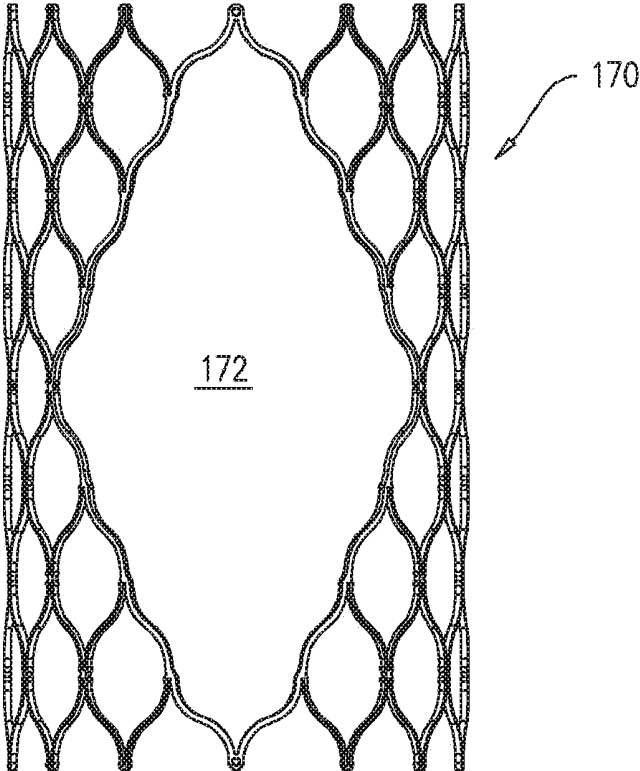

FIG. 24B

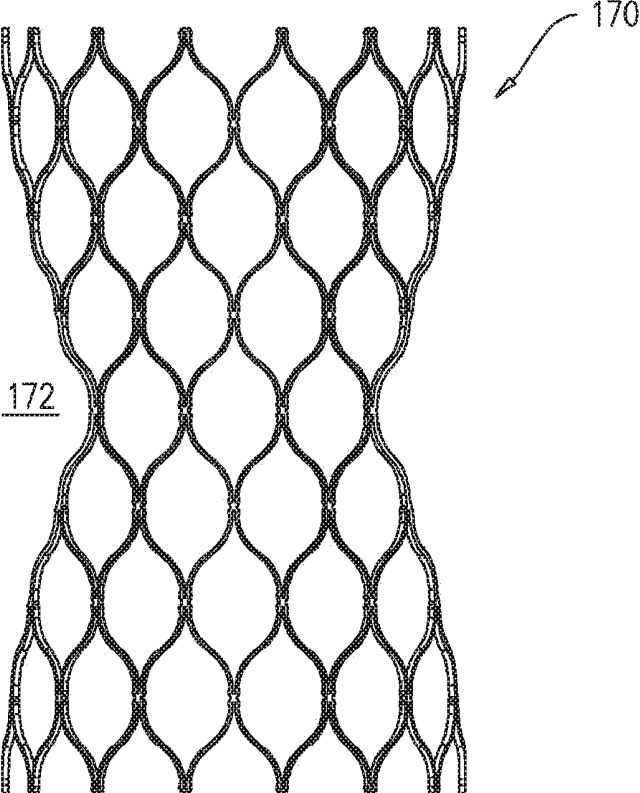

FIG. 25A

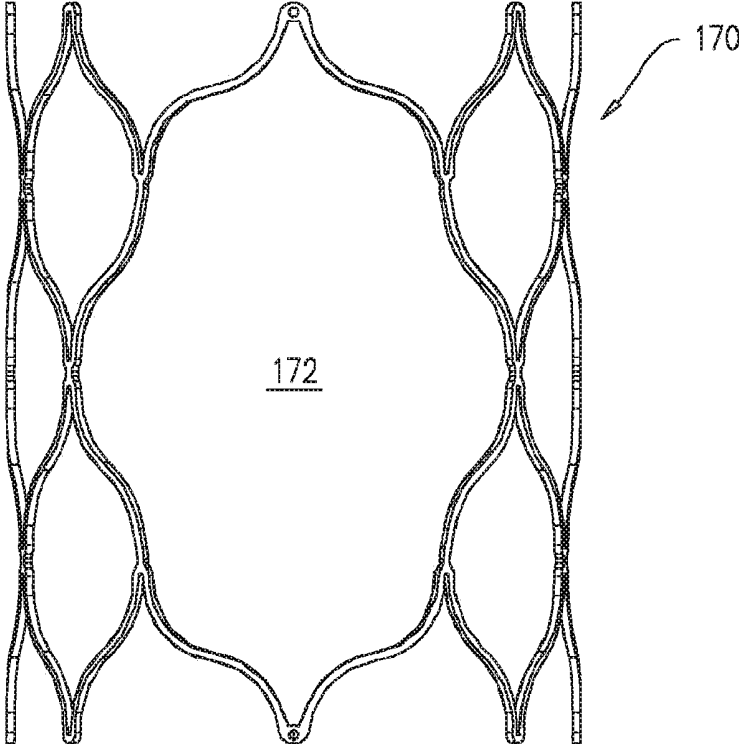

FIG. 25B

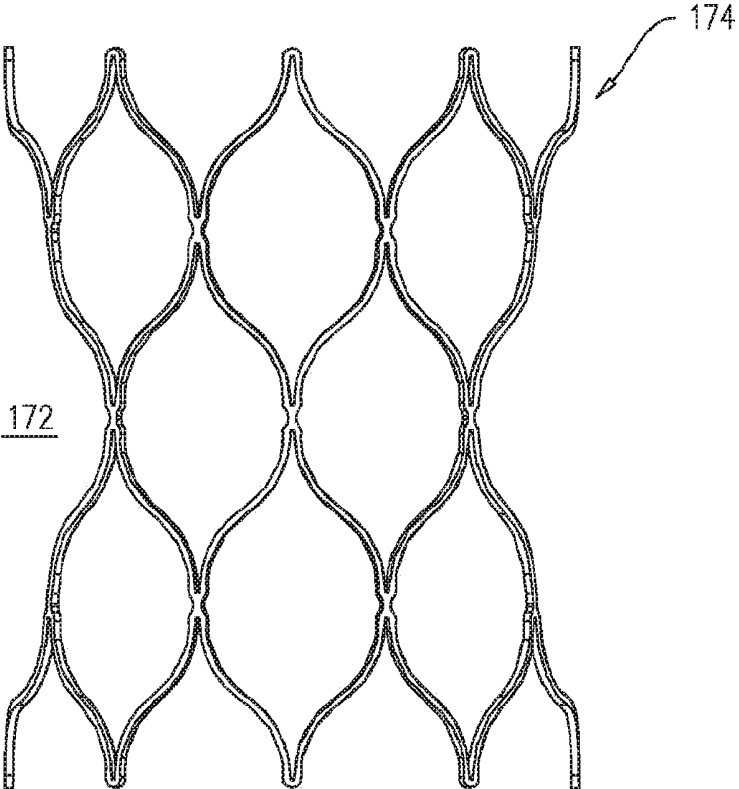

FIG. 26A

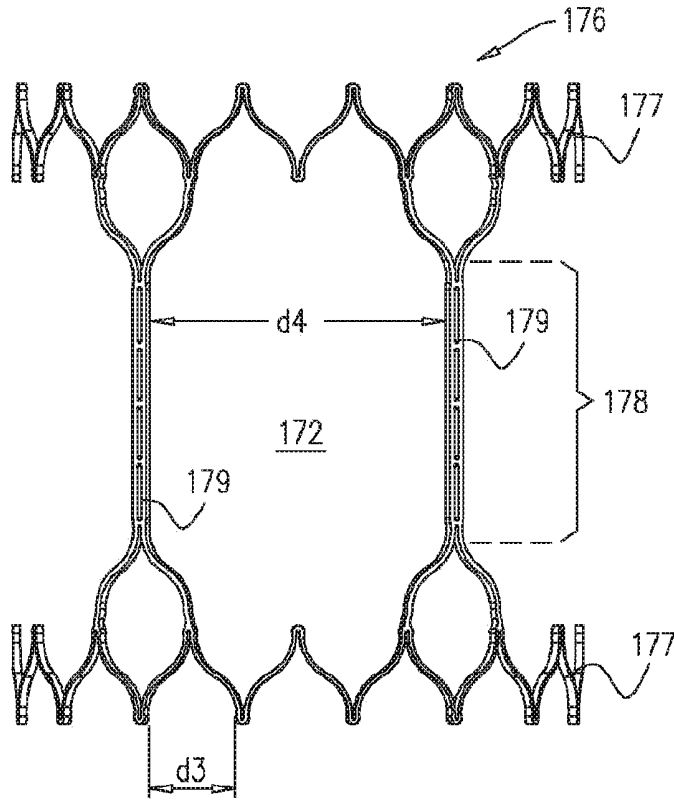

FIG. 26B

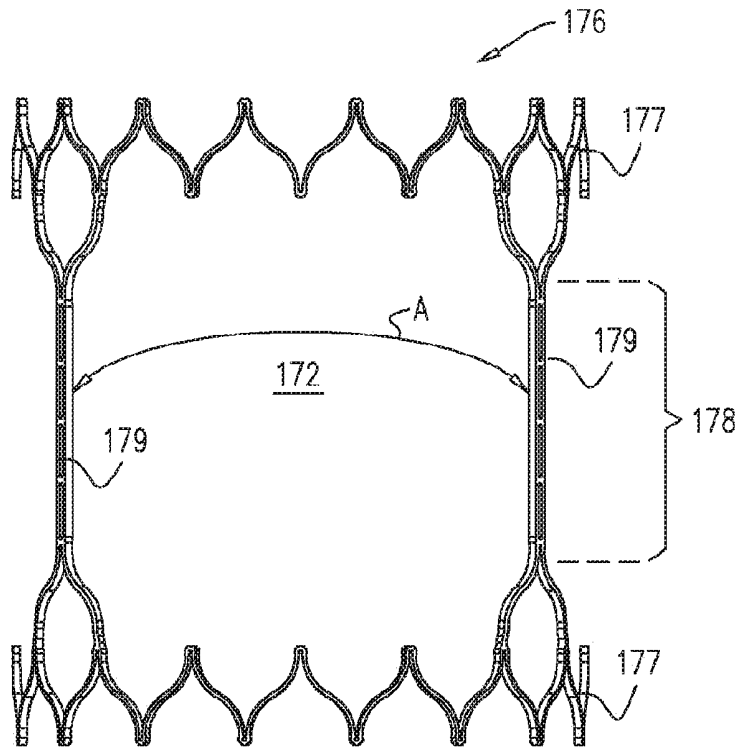

FIG. 27A

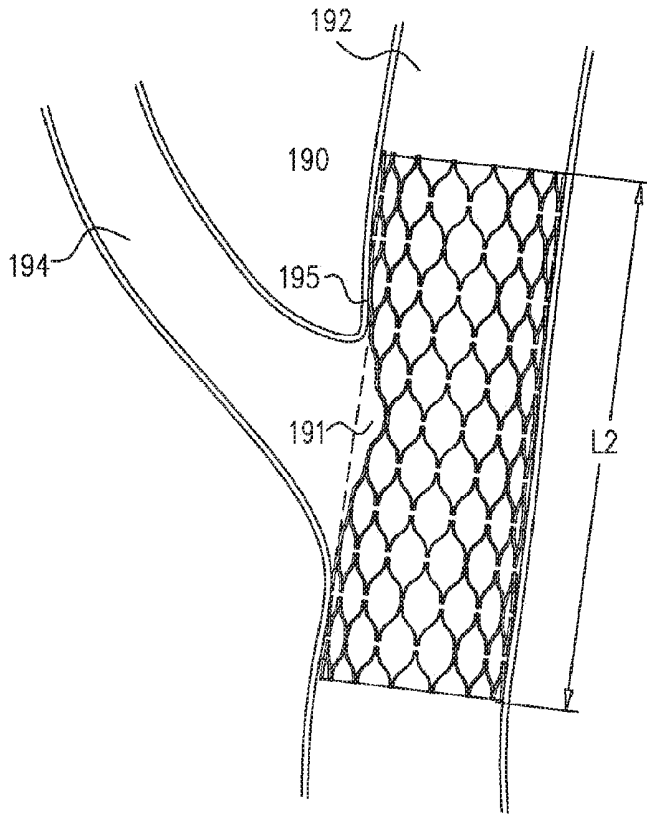

FIG. 27B

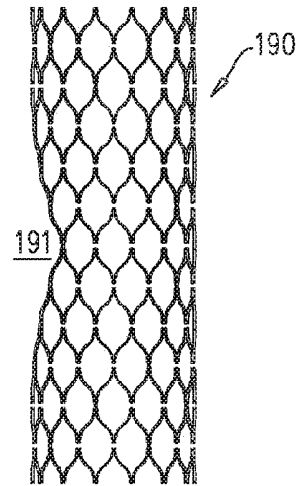

FIG. 27C

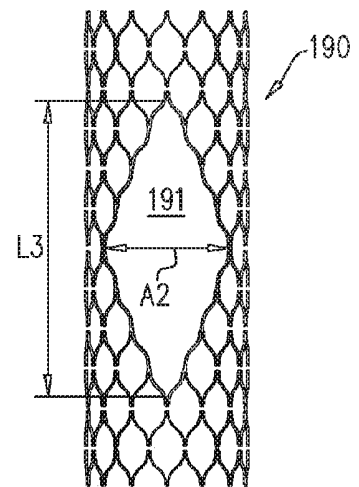
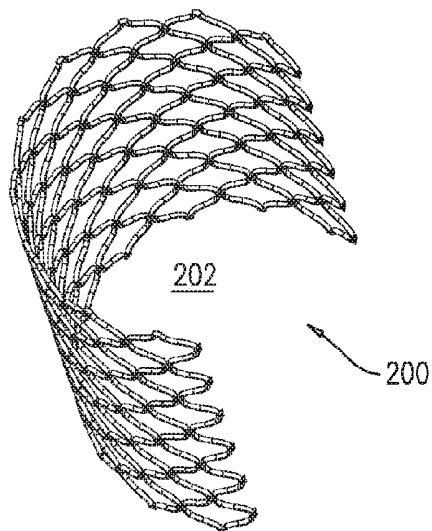

FIG. 27D



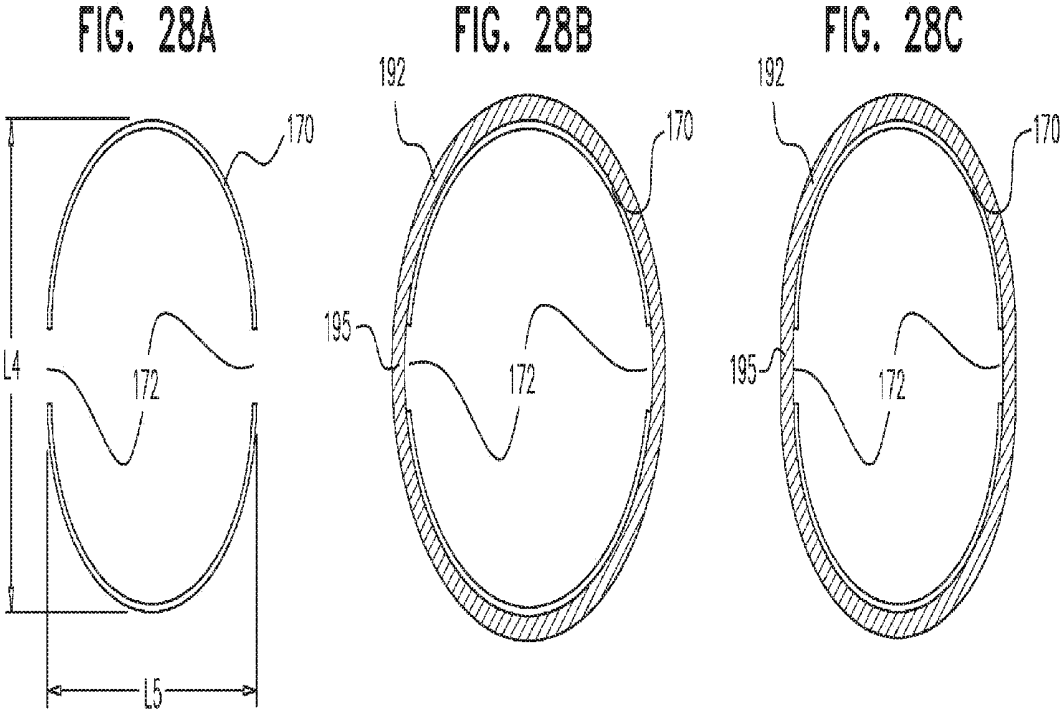

FIG. 29

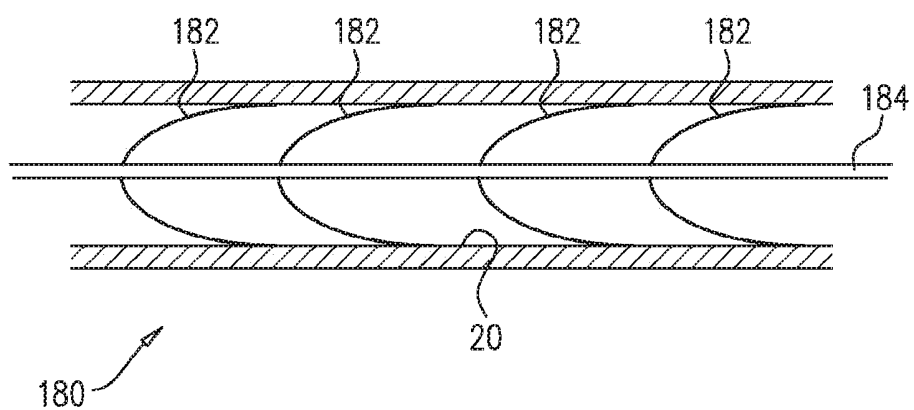

FIG. 30

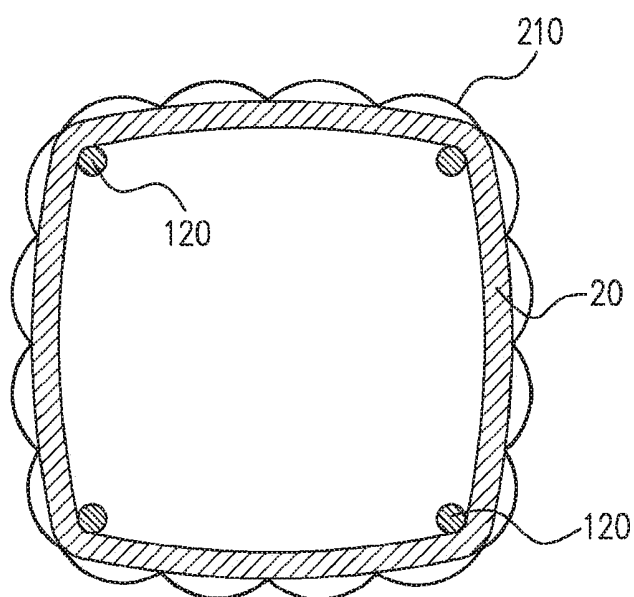

FIG. 31A

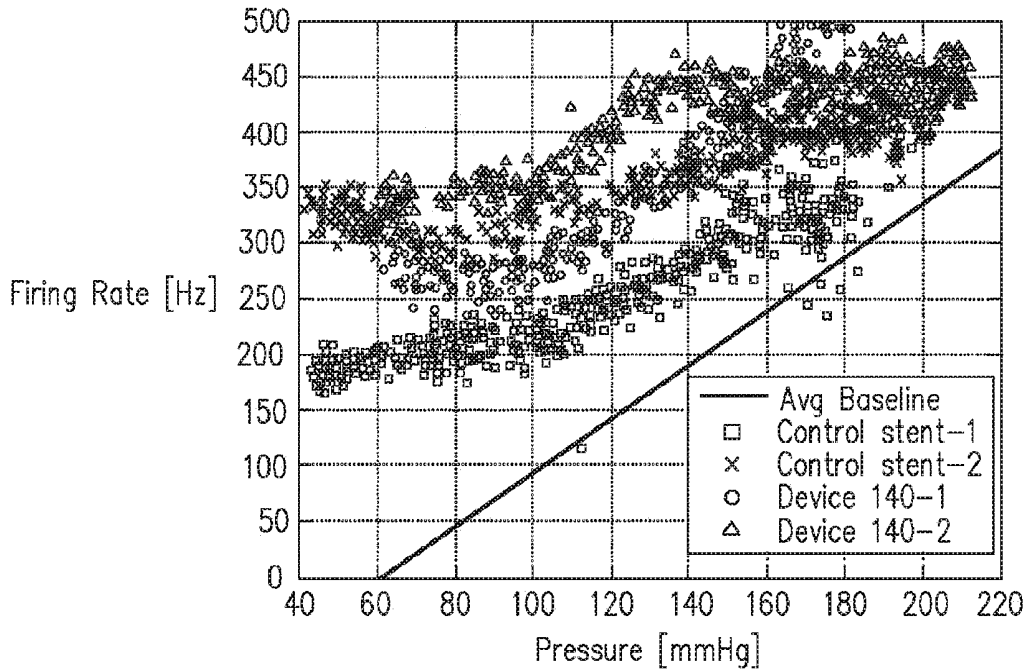

FIG. 31B

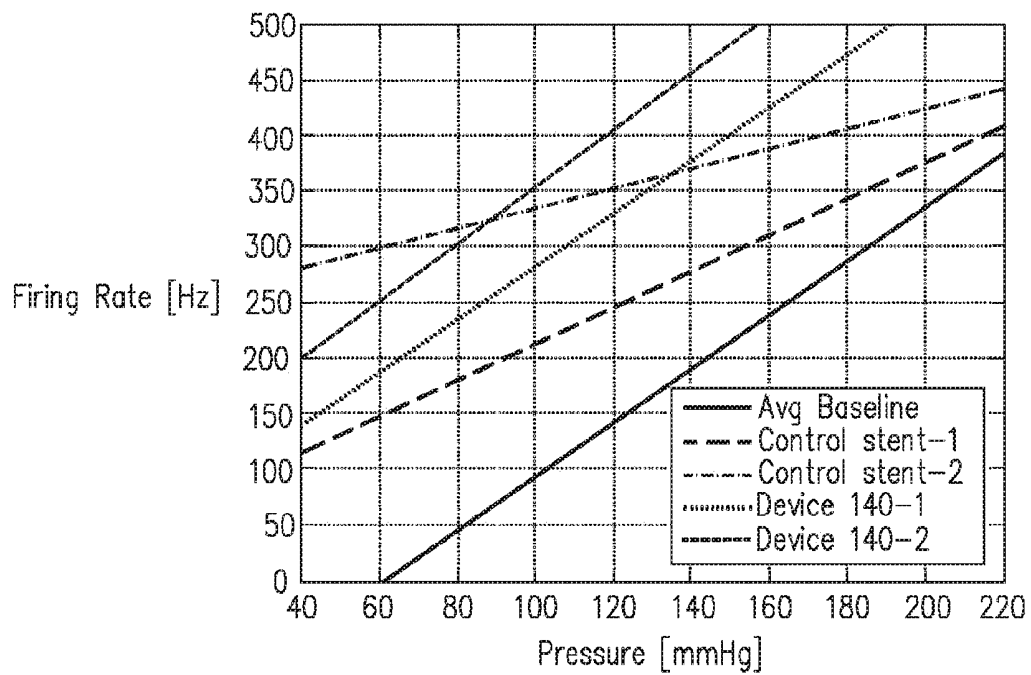

FIG. 31C

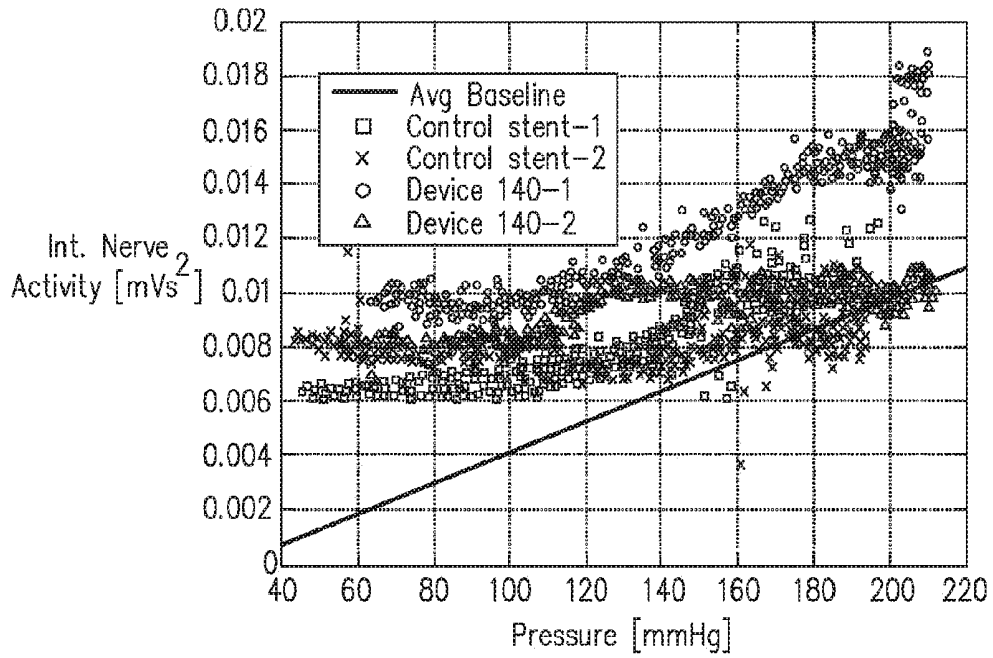
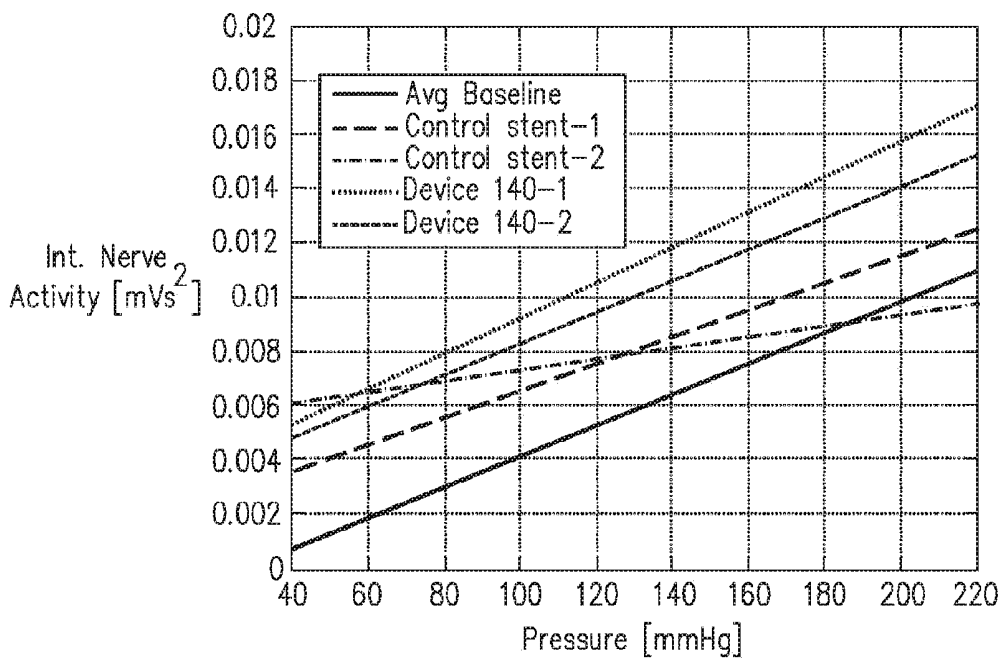

FIG. 31D



## DEVICES AND METHODS FOR CONTROL OF BLOOD PRESSURE

### CROSS-REFERENCES TO RELATED APPLICATIONS

[0001] This application is a divisional of U.S. patent application Ser. No. 13/455,005, filed Apr. 24, 2012, which is a continuation-in-part of U.S. patent application Ser. No. 12/774,254, filed May 5, 2010, and a continuation-in-part of U.S. patent application Ser. No. 13/030,384, filed Feb. 18, 2011, now U.S. Pat. No. 9,125,732, which is a continuation-in-part of U.S. patent application Ser. No. 12/774,254, filed May 5, 2010, the entire contents of which are incorporated herein by reference.

[0002] The present application is related to U.S. patent application Ser. No. 11/881,256 (US 2008/0033501), filed Jul. 25, 2007, entitled "Elliptical element for blood pressure reduction," which is a continuation-in-part of PCT Application No. PCT/IL2006/000856 to Gross (WO 07/013065), filed Jul. 25, 2006, entitled, "Electrical stimulation of blood vessels," which claims the benefit of (a) U.S. Provisional Application 60/702,491, filed Jul. 25, 2005, entitled, "Electrical stimulation of blood vessels," and (b) U.S. Provisional Application 60/721,728, filed Sep. 28, 2005, entitled, "Electrical stimulation of blood vessels." The present application is related to U.S. patent application Ser. No. 12/602,787 (published as US 2011/0213408), which is the U.S. national phase of PCT Application No. PCT/IL2009/000932 to Gross et al. (WO 10/035271), filed Sep. 29, 2009, which claims priority from U.S. Provisional Patent Application 61/194,339, filed Sep. 26, 2008, entitled "Devices and methods for control of blood pressure." All of the above applications are incorporated herein by reference.

### BACKGROUND OF THE INVENTION

#### 1. Field of the Invention

[0003] Some applications of the present invention generally relate to implanted medical apparatus. Specifically, some applications of the present invention relate to apparatus and methods for reducing blood pressure.

[0004] Hypertension is a condition from which many people suffer. It is a constant state of elevated blood pressure which can be caused by a number of factors, for example, genetics, obesity or diet. Baroreceptors located in the walls of blood vessels act to regulate blood pressure. They do so by sending information to the central nervous system (CNS) regarding the extent to which the blood vessel walls are stretched by the pressure of the blood flowing therethrough. In response to these signals, the CNS adjusts certain parameters so as to maintain a stable blood pressure.

### BRIEF SUMMARY OF THE INVENTION

[0005] For some applications, a subject's hypertension is treated by modulating the subject's baroreceptor activity. Mechanical and other forces are applied directly or indirectly to one or more of the subject's arteries in order to modulate the baroreceptor response to the blood pressure. The forces are typically applied to arteries that are rich in baroreceptors, for example, the carotid arteries, the aorta, the subclavian arteries and/or arteries of the brain. For some

applications, the forces are applied to other regions of the body that contain baroreceptors, such as the atria, the renal arteries, or veins.

[0006] Baroreceptors measure strain, which, in the case of a circular vessel, depends on the pressure and the radius of the vessel. As pressure increases, the stress exerted on the wall increases, thereby increasing the strain in the vessel wall. Equation 1 relates the wall stress  $\sigma$  in a thin walled tube, to internal pressure  $p$ , internal radius  $r$ , and wall thickness  $t$ .

$$\sigma = pr/2t \quad [\text{Equation 1}]$$

[0007] In a hypertensive patient, the pressure-strain relationship is typically shifted to higher pressures, such that the artery is subject to a given strain at a higher blood pressure than the blood pressure in a healthy vessel that would give rise to the given strain. Thus, the baroreceptors are activated at a higher blood pressure in a hypertensive patient than they are in a healthy patient. The devices described herein typically cause the pressure-strain curve to shift back to lower pressures.

[0008] The inventors hypothesize that, at constant pressure, by increasing the radius of curvature of a region of an arterial wall, the strain in the region of the wall may be increased. Thus, the baroreceptor nerve endings in the region (which are typically disposed between the medial and adventitial layers of the artery, as described in further detail hereinbelow) experience greater strain, *ceteris paribus*. The intravascular devices described herein typically increase the radius of curvature of regions of the arterial wall, but do not cause a substantial decrease in the cross-section of the artery (and, typically, cause an increase in the cross-section of the artery), thereby maintaining blood flow through the artery. For some applications, the devices change the shape of the artery such that the artery is less circular than in the absence of the device, thereby increasing the radius of curvature of sections of the arterial wall.

[0009] Typically, the devices described herein change the shape of the artery by being placed inside or outside the artery, but by maintaining less than 360 degrees of contact with the surface of the artery at any given site along the length of the artery. Further typically, contact between the device and the artery is limited to several (e.g., two to six, or three to six) contact regions around the circumference of the artery, and is generally minimized. Still further typically, the device is placed inside the artery such that there are several regions at which the device does not contact the artery, each of the non-contact regions being contiguous, and defining an angle that is greater than 10 degrees around the longitudinal axis of the artery, as described in further detail hereinbelow. This may be beneficial for the following reasons:

[0010] (1) A greater area of the artery pulsates in response to pressure changes than if the device were to maintain a greater degree of contact with the vessel wall. It is generally desirable to allow at least a portion of the vessel to pulsate freely. This is because pulsation of the vessel over the course of the cardiac cycle typically activates and maintains normal functioning of the baroreceptors. For some applications, baroreceptor activity in the portions of the vessel that are in contact with the device may be reduced, since the movement of those portions in response to changes in blood pressure is reduced. Therefore, for some applications, contact between the device and the artery is minimized.

**[0011]** (2) A smaller metal to lumen ratio typically causes less reactive growth of endothelial and smooth muscle cells. Typically, reducing this reactive growth reduces the chances of stenosis being caused by the device. Further typically, reducing this reactive growth facilitates explantation, and/or movement of the device, when desired.

**[0012]** For some applications the devices described herein are implanted temporarily, and are subsequently removed. For example, one of the devices described herein may be implanted for a period of less than one month, e.g., less than one week. Temporary implantation of the devices is typically used to treat an acute condition of the subject. For some applications, the shape of the artery in which the device is implanted is permanently altered by temporarily implanting the device.

**[0013]** Typically, the devices described herein are implanted inside or outside of the subject's carotid artery, e.g., in the vicinity of the carotid bifurcation. In accordance with respective embodiments, the devices are implanted bilaterally, or inside or outside of only one of the subject's carotid arteries. Alternatively or additionally, the devices are placed inside or outside of a different artery, e.g., the aorta or the pulmonary artery.

**[0014]** The devices are typically self-anchoring and structurally stable. Further typically, the devices are passive devices, i.e., subsequent to the devices being implanted inside or outside of the artery, the devices act to increase baroreceptor sensitivity without requiring electrical or real-time mechanical activation.

**[0015]** There is therefore provided, in accordance with some applications of the present invention, apparatus including:

**[0016]** an implantable device having first and second longitudinal ends, the device having a length of less than 80 mm when the device is unconstrained,

the device including struts, arranged such that, when the device is unconstrained, along a continuous portion of the device having a length that is at least 5 mm, a maximum inter-strut distance defined by any set of two adjacent struts is more than 1.5 times as great as a maximum inter-strut distance defined by any set of two adjacent struts within longitudinal portions of the device within 3 mm of the longitudinal ends of the device.

**[0017]** For some applications, the device is configured to lower blood pressure of a patient, by being implanted proximate to a baroreceptor within an artery of the subject.

**[0018]** For some applications, the continuous portion of the device includes a portion of a region of the device that defines no struts, the region having a non-circular shape.

**[0019]** For some applications, the continuous portion of the device includes a portion of a region of the device that defines no struts, a center of the region being disposed asymmetrically with respect to a length of the device.

**[0020]** For some applications, along the continuous portion of the device, the maximum inter-strut distance defined by any set of two adjacent struts is more than 3 times as great as the maximum inter-strut distance defined by any set of two adjacent struts within longitudinal portions of the device within 3 mm of the longitudinal ends of the device.

**[0021]** For some applications, the device has a length of less than 50 mm.

**[0022]** For some applications, the device has a spring constant of less than 2 N/mm.

**[0023]** For some applications, the device has a spring constant of less than 1.5 N/mm.

**[0024]** For some applications, along the continuous portion of the device, the maximum inter-strut distance defines an arc of more than 30 degrees around a longitudinal axis of the device.

**[0025]** For some applications, along the continuous portion of the device, the maximum inter-strut distance defines an arc of more than 60 degrees around the longitudinal axis of the device.

**[0026]** For some applications, within the longitudinal portions of the device within 3 mm of the longitudinal ends of the device the struts define angles therebetween, within the continuous portion the struts define angles therebetween, and a minimum angle defined by the struts within the longitudinal portions of the device within 3 mm of the longitudinal ends of the device is greater than a minimum angle defined by the struts within the continuous portion.

**[0027]** For some applications, a ratio of the minimum angle defined by the struts within the longitudinal portions of the device within 3 mm of the longitudinal ends of the device to the minimum angle defined by the struts within the continuous portion is greater than 1.25.

**[0028]** For some applications, the ratio of the minimum angle defined by the struts within the longitudinal portions of the device within 3 mm of the longitudinal ends of the device to the minimum angle defined by the struts within the continuous portion is greater than 2.

**[0029]** There is further provided, in accordance with some applications of the present invention, apparatus including:

**[0030]** an implantable device that is shaped to define struts arranged such that, when the device is unconstrained, along a continuous portion of the device having a length that is at least 5 mm, a maximum inter-strut distance defined by any set of two adjacent struts is more than 5 mm,

**[0031]** the implantable device having a length of less than 80 mm when the device is unconstrained,

**[0032]** the implantable device, at any location along the length of the device, defining a ratio of a perimeter of a cross-section of the device at the location to the cross-sectional area defined by the struts of the device at the longitudinal location, and

**[0033]** the implantable device defining a maximum value of said ratio,

**[0034]** the ratio being more than 80 percent of the maximum value of the ratio along more than 80 percent of a length of the device.

**[0035]** For some applications, the device is configured to lower blood pressure of a patient, by being implanted proximate to a baroreceptor within an artery of the subject.

**[0036]** For some applications, the continuous portion of the device includes a portion of a region of the device that defines no struts, the region having a non-circular shape.

**[0037]** For some applications, the continuous portion of the device includes a portion of a region of the device that defines no struts, a center of the region being disposed asymmetrically with respect to a length of the device.

**[0038]** For some applications, the device has a length of less than 50 mm.

**[0039]** For some applications, the device has a spring constant of less than 2 N/mm.

**[0040]** For some applications, the device has a spring constant of less than 1.5 N/mm.

**[0041]** For some applications, along the continuous portion of the device, the maximum inter-strut distance defines an arc of more than 30 degrees around a longitudinal axis of the device.

**[0042]** For some applications, along the continuous portion of the device, the maximum inter-strut distance defines an arc of more than 60 degrees around the longitudinal axis of the device.

**[0043]** For some applications, along the continuous portion of the device, the maximum inter-strut distance defined by any set of two adjacent struts is more than 1.5 times as great as a maximum inter-strut distance defined by any set of two adjacent struts within longitudinal portions of the device within 3 mm of longitudinal ends of the device.

**[0044]** For some applications, along the continuous portion of the device, the maximum inter-strut distance defined by any set of two adjacent struts is more than 3 times as great as the maximum inter-strut distance defined by any set of two adjacent struts within the longitudinal portions of the device within 3 mm of longitudinal ends of the device.

**[0045]** There is additionally provided, in accordance with some applications of the present invention, apparatus including:

**[0046]** an implantable device that is shaped to define struts, the device being shaped such that over a continuous portion of the device having a length that is at least 5 mm, the device defines at least one circumferential region in which no struts are disposed, the region defining an arc of at least 30 degrees around a longitudinal axis of the device,

**[0047]** a cross-sectional shape of the device at the region being shaped to define a major axis and a minor axis, at least when the device is in a non-constrained state thereof,

**[0048]** a major axis of the cross-sectional shape being parallel to a plane defined by the region in which no struts are disposed, and a minor axis of the cross-sectional shape being perpendicular to the plane.

**[0049]** For some applications, the device is configured to lower blood pressure of a patient, by being implanted proximate to a baroreceptor within an artery of the subject.

**[0050]** For some applications, the region defines an arc of at least 60 degrees around the longitudinal axis of the device.

**[0051]** There is additionally provided, in accordance with some applications of the present invention, a method including:

**[0052]** providing an implantable device having first and second longitudinal ends, the device including struts, arranged such that, when the device is unconstrained, along a continuous portion of the device having a length that is at least 5 mm, a maximum inter-strut distance defined by any set of two adjacent struts is more than 1.5 times as great as a maximum inter-strut distance defined by any set of two adjacent struts within longitudinal portions of the device within 3 mm of the longitudinal ends of the device; and

**[0053]** implanting the device in a carotid artery of a subject.

**[0054]** For some applications, the method further includes identifying the subject as suffering from hypertension, and implanting the device in the subject's carotid artery includes lowering blood pressure of the subject.

**[0055]** There is additionally provided, in accordance with some applications of the present invention, a method, including:

**[0056]** providing an implantable device,

**[0057]** the device being shaped to define struts arranged such that, when the device is unconstrained, over a continuous portion of the device having a length that is at least 5

mm, a maximum inter-strut distance defined by any set of two adjacent struts is more than 5 mm,

**[0058]** a ratio of a perimeter of a cross-section of the device at any at any location along the length of the device, being more than 80 percent of the maximum value of the ratio along more than 50 percent of a length of the device; and

**[0059]** implanting the device in a carotid artery of a subject.

**[0060]** For some applications, the method further includes identifying the subject as suffering from hypertension, and implanting the device in the subject's carotid artery includes lowering blood pressure of the subject.

**[0061]** There is further provided, in accordance with some applications of the present invention, a method, including:

**[0062]** providing an implantable device that is shaped to define struts,

**[0063]** the device being shaped such that over a continuous portion of the device having a length that is at least 5 mm, the device defines at least one circumferential region in which no struts are disposed, the region defining an arc of at least 30 degrees around a longitudinal axis of the device,

**[0064]** a cross-sectional shape of the device at the region being shaped to define a major axis and a minor axis, at least when the device is in a non-constrained state thereof,

**[0065]** the major axis of the cross-sectional shape being parallel to a plane defined by the region in which no struts are disposed, and the minor axis of the cross-sectional shape being perpendicular to the plane; and

**[0066]** implanting the device in a carotid artery of a subject.

**[0067]** For some applications, the method further includes identifying the subject as suffering from hypertension, and implanting the device in the subject's carotid artery includes lowering blood pressure of the subject.

**[0068]** The present invention will be more fully understood from the following detailed description of embodiments thereof, taken together with the drawings, in which:

#### BRIEF DESCRIPTION OF THE DRAWINGS

**[0069]** FIG. 1 is a cross-sectional illustration of an artery;

**[0070]** FIGS. 2A-B are contour plots of the strain in the wall of an artery, respectively, when the artery does have and does not have inserted therein an intravascular device, in accordance with some applications of the present invention;

**[0071]** FIG. 3 is a contour plot of the strain in the wall of an artery, an extravascular device having been implanted outside the wall, in accordance with some applications of the present invention;

**[0072]** FIG. 4 is a schematic illustration of an intravascular device for placing inside an artery of a subject suffering from hypertension, in accordance with some applications of the present invention;

**[0073]** FIGS. 5A-B are schematic illustrations of an artery, showing the radius of curvature of the artery, respectively, before and after placement of the device shown in FIG. 4, in accordance with some applications of the present invention;

**[0074]** FIG. 5C is a schematic illustration of the device of FIG. 4 disposed inside the artery, without stretching the artery, for illustrative purposes;

**[0075]** FIGS. 6A-B are schematic illustrations of, respectively, a device, and the device implanted inside an artery, in accordance with some applications of the present invention;

[0076] FIGS. 7A-B are schematic illustrations of, respectively, another device, and the device implanted inside an artery, in accordance with some applications of the present invention;

[0077] FIGS. 8A-B are schematic illustrations of, respectively, a further device, and the device implanted inside an artery, in accordance with some applications of the present invention;

[0078] FIGS. 9A-D are schematic illustrations of extravascular devices placed around an artery, in accordance with some applications of the present invention;

[0079] FIG. 10 is a graph that indicates the portion of an arterial wall having a strain that is greater than a threshold value, as a function of the reduction in the cross-sectional area of the artery, for respective extravascular devices, in accordance with some applications of the present invention;

[0080] FIG. 11 is a graph showing the maximum percentage increase in the strain of the arterial wall as a function of the reduction in the cross-sectional area of the artery, for respective extravascular devices, in accordance with some applications of the present invention;

[0081] FIG. 12 is a schematic illustration of a device for measuring the baroreceptor response of a subject to pressure that is exerted on the inner wall of an artery of the subject, in accordance with some applications of the present invention;

[0082] FIG. 13 is a graph showing the blood pressure measured in a dog before and after the insertion of intravascular devices into the dog's carotid sinuses, in accordance with some applications of the present invention;

[0083] FIG. 14 is a graph showing the pressure-strain curve of the artery of a healthy subject, a hypertensive subject, and a hypertensive subject that uses a device as described herein, in accordance with some applications of the present invention;

[0084] FIGS. 15A-B, and 15E are schematic illustrations of a device for placing in a subject's artery, in accordance with some applications of the present invention;

[0085] FIGS. 15C-D are schematic illustrations of an arterial wall exerting a force on struts of a device, in accordance with some applications of the present invention;

[0086] FIGS. 16A-D are schematic illustrations of another device for placing in a subject's artery, in accordance with some applications of the present invention;

[0087] FIGS. 17A-D are schematic illustrations of yet another device for placing in a subject's artery, in accordance with some applications of the present invention;

[0088] FIGS. 18A-D are schematic illustrations of further devices for placing in a subject's artery, in accordance with some applications of the present invention;

[0089] FIG. 19 is a schematic illustration of a device having a D-shaped cross-section for placing in a subject's artery, in accordance with some applications of the present invention;

[0090] FIG. 20 is a schematic illustration of an intra-arterial device that includes a mesh between artery contact regions of the device, in accordance with some applications of the present invention;

[0091] FIG. 21 is a graph showing the derivative of strain versus pressure as a function of rotational position around the artery, in accordance with respective models of an artery, in accordance with some applications of the present invention;

[0092] FIGS. 22A-C are schematic illustrations of a delivery device for placing an intra-arterial device at a subject's carotid bifurcation, in accordance with some applications of the present invention;

[0093] FIGS. 23A-B, 24A-B, 25A-B, 26A-B, 27A-D, and 28A-C are schematic illustration of stent-based intra-arterial devices, in accordance with some applications of the present invention;

[0094] FIG. 29 is a schematic illustration of a further intra-arterial device, in accordance with some applications of the present invention;

[0095] FIG. 30 is a schematic illustration of an extra-arterial device configured to be placed around the outside of an artery, in accordance with some applications of the present invention;

[0096] FIGS. 31A-B are graphs showing the Herring's nerve firing rate at respective blood pressures recorded in dogs that had been implanted with medical devices, in accordance with some applications of the present invention; and

[0097] FIGS. 31C-D are graphs showing the Herring's nerve integrated nerve activity at respective blood pressures recorded in dogs that been implanted with medical devices, in accordance with some applications of the present invention.

#### DETAILED DESCRIPTION OF THE INVENTION

[0098] Reference is now made to FIG. 1, which is a cross-sectional illustration of an artery 20. The arterial wall includes three layers 22, 24, and 26, which are called, respectively, the intima, the media, and the adventitia. For some applications of the present invention, an intravascular device is placed inside an artery, baroreceptors being disposed at the interface between adventitia 26 and media 24 of the artery. The device causes the curvature of the arterial wall to flatten in some regions of the circumference of the arterial wall, thereby causing the baroreceptors to become stretched, while allowing the regions to pulsate over the course of the subject's cardiac cycle.

[0099] Reference is now made to FIGS. 2A and 2B, which are contour plots of the strain in the top right quarter of an arterial wall, in the absence of an intravascular device (FIG. 2A) and in the presence of an intravascular device (FIG. 2B), analyzed and/or provided in accordance with some applications of the present invention. The contour plot in FIG. 2B was generated for a device (e.g., as shown hereinbelow in FIGS. 7A-B) having four elements, each of which contacts the arterial wall at a contact region 42. The contour plots shown in FIGS. 2A-B are computer simulations of the strain in the wall of an artery, at a blood pressure of 100 mmHg, the artery having a radius of 3 mm, and a wall thickness of 0.6 mm. The scope of the present application includes intravascular devices having different structures from that used to generate FIG. 2B, as would be obvious to one skilled in the art.

[0100] As seen in FIGS. 2A-B, relative to the strain in the arterial wall in the absence of an intravascular device, the intravascular device causes there to be increased strain in the arterial wall both (a) in the vicinity of contact regions 42, at which the arterial wall becomes more curved than in the absence of the device, and (b) in flattened regions 44 of the wall, in which regions the arterial wall is flatter than it is in the absence of the device. Thus, the intravascular device

increases the strain in the arterial wall even in regions of the arterial wall which are able to pulsate, i.e., flattened regions 44. The increased strain in the flattened regions relative to the strain in the wall in the absence of the intravascular device is due to the increased radius of curvature of the flattened regions of the wall.

[0101] Reference is now made to FIG. 3, which is a contour plot of the strain in the top right quarter of an arterial wall, in the presence of an extravascular device, in accordance with some applications of the present invention. The contour plot in FIG. 3 was generated for a device having four elements that contact the artery at four contact regions 52. However, the scope of the present invention includes extravascular devices having different structures, as described hereinbelow. For example, an extravascular device may provide three to six contact regions. The contour plot shown in FIG. 3 is a computer simulation of the strain in the wall of an artery, at a blood pressure of 100 mmHg, the artery having a radius of 3 mm, and a wall thickness of 0.6 mm.

[0102] As may be observed by comparing FIG. 3 to FIG. 2A, the extravascular device causes there to be strain in the arterial wall in the vicinity of contact regions 52, at which the arterial wall becomes more curved than in the absence of the device. Furthermore, it may be observed that the strain at non-contact regions 54 of the wall is lower than in the absence of the device. The extravascular device typically breaks the circumferential symmetry of the arterial strain by applying force at discrete points or surfaces around the sinus. For some applications, the extravascular device increases the strain in certain regions of the arterial wall, and decreases the strain in other regions of the arterial wall, while maintaining the average strain almost unchanged or even slightly reduced with respect to the strain in the wall in the absence of the device. For some applications, the extravascular device increases the strain in the arterial wall even at non-contact regions 54, by causing the non-contact regions to become more curved than in the absence of the device.

[0103] Reference is now made to FIG. 4, which is a schematic illustration of an intravascular device 60 for placing inside artery 20 of a subject suffering from hypertension, in accordance with some applications of the present invention. As shown, device 60 contacts the arterial wall at two contact regions 62. At the contact regions, device 60 pushes the arterial wall outward, thereby flattening non-contact regions 64 of the arterial wall between the contact regions. Typically, non-contact regions 64 are flattened, or partially flattened during diastole of the subject, but expand during systole such that they become more curved than during diastole. Therefore, strain in the flattened regions of the arterial wall is increased. However, the flattened regions still pulsate over the course of the subject's cardiac cycle in the presence of device 60.

[0104] As shown, device 60 is shaped such that the device substantially does not reduce blood flow. Typically, device 60 is shaped such that no portion of the device intersects the longitudinal axis of the artery. For example, as shown, contact surfaces of the device (which contact the arterial wall at contact regions 60) are coupled to each other by a joint 66 that does not intersect the longitudinal axis of the artery. The joint is disposed asymmetrically with respect to centers of the contact surfaces of the device.

[0105] Reference is now made to FIGS. 5A-B, which are schematic illustrations of an artery, showing the radius  $R$  of artery 20, respectively, before and after placement of the device 60 shown in FIG. 4, in accordance with some applications of the present invention. It may be observed that, for some applications, insertion of device 60 increases the systolic radius of curvature of the artery at non-contact regions 64, for example, such that the radius of curvature at non-contact regions 64 is more than 1.1 times (e.g., twice, or more than twenty times) the systolic radius of curvature of regions 64 in the absence of device 60, *ceteris paribus*. For some applications, device 60 causes the radius of curvature of at least a portion of a non-contact region to become infinite, by flattening the non-contact regions. For example, the center of non-contact region 64 in FIG. 5B has an infinite radius of curvature.

[0106] For some applications, device 60 increases the systolic radius of curvature of the artery at non-contact regions 64 in the aforementioned manner, and increases the systolic cross-sectional area of the artery by more than five percent (e.g., ten percent), relative to the systolic cross-sectional area of the artery in the absence of device 60.

[0107] In accordance with the description hereinabove, by flattening non-contact regions 64 of the wall of artery 20, device 60 causes increased strain in regions 64, thereby causing an increase in baroreceptor firing at regions 64. Alternatively or additionally, device 60 causes increased baroreceptor firing at contact regions 62, by deforming the arterial wall at the contact regions.

[0108] Typically, device 60 exerts a force on artery 20, such that, during systole when the artery is in the stretched configuration shown in FIG. 5B, non-contact regions 64 comprise more than ten percent, e.g., more than 20 percent, of the circumference of the arterial wall at longitudinal sites at which device 60 stretches the artery. For some applications, during systole, non-contact regions 64 comprise more than 60 percent, e.g., more than 80 percent, of the circumference of the arterial wall at longitudinal sites at which device 60 stretches the artery.

[0109] Reference is now made to FIG. 5C, which shows device 60 disposed inside artery 20, but without the device stretching artery 20. FIG. 5C is for illustrative purposes, since typically once device 60 is inserted into the artery, the device will stretch the artery, as shown in FIG. 5B. FIG. 5C demonstrates that the device contacts the walls of the artery at contact regions 62 at less than 360 degrees of the circumference of the artery at any longitudinal point along artery 20 (e.g., at the cross-section shown in FIGS. 5A-C). As shown in FIG. 5C, each of the contact regions 62 encompasses an angle  $\alpha$  of the circumference of the artery, such that the contact that device 60 makes with the walls of the artery encompasses two times  $\alpha$  degrees. For devices that contact the artery at more than two contact regions, the contact that the device makes with the walls of the artery encompasses an angle that is a correspondingly greater multiple of  $\alpha$  degrees. Typically, device 60 (and the other intravascular devices described herein) contacts the walls of the artery at less than 180 degrees (e.g., less than 90 degrees) of the circumference of the artery at any longitudinal site along the artery. Typically, device 60 contacts the walls of the artery at more than 5 degrees (e.g., more than 10 degrees) of the circumference of the artery at any longitudinal site along the artery. For example, device 60

may contact the walls of the artery at 5-180 degrees, e.g., 10-90 degrees, at a given longitudinal site.

[0110] Reference is now made to FIGS. 6A-B, which are schematic illustrations of, respectively, a device 70, and device 70 implanted inside artery 20, in accordance with some applications of the present invention. Device 70 contacts the wall of the artery at three contact regions 72, thereby increasing the radius of curvature (i.e., flattening) of non-contact regions 74 of the artery that are between the contact regions. The flattened non-contact regions and the contact regions alternate with each other. The flattened non-contact regions are typically able to pulsate over the course of the subject's cardiac cycle, as described hereinabove. As shown in FIG. 6B, each contiguous non-contact region at a given longitudinal site of the artery, encompasses an angle beta around a longitudinal axis 76 of the artery. For some devices (e.g., device 70, and device 90 described hereinbelow with reference to FIGS. 8A-B), the angle beta is also defined by the angle that edges of adjacent contact regions of the device define around longitudinal axis 78 of the device. When the device is placed in the artery longitudinal axis 78 of the device is typically aligned with longitudinal axis 76 of the artery. Typically, angle beta is greater than 10 degree, e.g., greater than 20 degree, or greater than 50 degrees. Further typically, angle beta is less than 180 degrees, e.g., less than 90 degrees. For some applications angle beta is 10-180 degree, e.g., 20-90 degrees. Typically, each of the contiguous non-contact regions is able to pulsate.

[0111] Reference is now made to FIGS. 7A-B, which are schematic illustrations of, respectively, a device 80, and device 80 implanted inside artery 20, in accordance with some applications of the present invention. Device 80 contacts the wall of the artery at four contact regions, thereby flattening the non-contact regions of the artery that are between the contact regions. Each contiguous non-contact region at a given longitudinal site of the artery, encompasses an angle beta around the longitudinal axis of the artery, angle beta being as described hereinabove.

[0112] Reference is now made to FIGS. 8A-B, which are schematic illustrations of, respectively, a device 90, and device 90 implanted inside artery 20, in accordance with some applications of the present invention. Device 90 contacts the wall of the artery at five contact regions, thereby flattening the non-contact regions of the artery that are between the contact regions. Each contiguous non-contact region at a given longitudinal site of the artery, encompasses an angle beta around the longitudinal axis of, angle beta being as described hereinabove.

[0113] Apart from the fact that devices 70, 80, and 90 contact the artery at, respectively three, four, and five contact regions, devices 70, 80, and 90 function in a generally similar manner to each other, and to device 60, described with reference to FIGS. 4 and 5A-C. For example, devices 70, 80, and 90 typically contact the arterial wall around substantially less than 360 degrees of the circumference of the artery, for example, around 10-90 degrees, or around an angle as described hereinabove with reference to FIGS. 5A-C. Furthermore, devices 70, 80, and 90 typically increase the cross-sectional area of the artery relative to the cross-sectional area of the artery in the absence of the device.

[0114] For some applications, a device having three or more contact regions with the arterial wall, for example, as

shown in FIGS. 6A-8B, is used. It is noted that since device 60 (shown in FIG. 4) contacts the artery at two contact points, as the device applies increasing pressure to the artery, it will, at a given stage, decrease the cross-section of the artery, as the artery becomes increasingly elliptical. By contrast, devices 70, 80, and 90, which contact the artery at three or more contact points, increase the cross-section of the artery, as they apply increasing pressure to the wall of the artery. Thus, for some applications, a device with three or more contact regions is used in order that the cross-sectional area of the artery is increased as the force which the device exerts on the wall increases, as compared with a device with only two contact regions.

[0115] Although devices that contact artery 20 at two, three, four and five contact regions have been described, the scope of the present invention includes devices that contact the artery at a different number of contact regions, and/or that have different structures from those shown, mutatis mutandis.

[0116] The intravascular devices described herein are generally shaped such that the devices contact the intravascular wall at relatively small contact regions, and provide relatively large contiguous non-contact regions, which are able to pulsate due to the subject's cardiac cycle.

[0117] The devices are typically shaped such that the total contact region that the device makes with the arterial wall at any longitudinal point along the artery is less than 2 mm, e.g., less than 0.5 mm. The contact region is usually larger than 0.05 mm, e.g., greater than 0.2 mm. For example, the contact region may be 0.05-2 mm, e.g., 0.1-0.4 mm, or 0.2-0.5 mm. The devices are typically inserted into an artery that has an internal circumference during systole of 6-8 mm. Thus, the intravascular devices described herein are typically configured to contact less than 35 percent of the circumference of the artery at any longitudinal point along the artery, and at any point in the subject's cardiac cycle (or, for at least a portion of the cardiac cycle). Further typically, the intravascular devices described herein are configured to contact more than 0.5 percent of the circumference of the artery at any longitudinal point along the artery, and at any point in the subject's cardiac cycle (or, for at least a portion of the cardiac cycle). For some applications, the contact region may be 0.5-35 percent of the circumference of the artery (or, for at least a portion of the cardiac cycle).

[0118] For some applications, the intravascular devices described herein have a total cross-sectional area of less than 5 sq mm, e.g., less than 0.8 sq mm, or less than 0.5 sq mm. (The total cross-sectional area should be understood to refer to the cross-sectional area of the solid portions of the devices, and not the space in between the solid portions.) The devices typically have this cross-sectional area over a length of the device of more than 4 mm, e.g., more than 6 mm, and/or less than 12 mm, e.g. less than 10 mm. For example, the devices may have the aforementioned cross sectional area over a length of 4 mm-12 mm, e.g., 6 mm-10 mm. The devices are typically manufactured from nitinol, cobalt chrome, and/or passivated stainless steel 316L.

[0119] Reference is now made to FIGS. 9A-D, which are schematic illustrations of extravascular devices 100 that are implanted around the outside of artery 20, in accordance with some applications of the present invention. For some applications, an extravascular device having three contact elements 102 (as shown in FIGS. 9A and 9C) is placed around the artery. Alternatively, the extravascular device has

a different number of contact elements **102**, e.g., four to six contact elements. The contact elements increase the strain in the arterial wall at the regions at which the contact elements contact the arterial wall, relative to the strain in the arterial wall in the absence of device **100**. For some applications, the device increases the strain in the arterial wall even at regions of the arterial wall between the contact regions, relative to the strain of the arterial wall in the absence of the device.

**[0120]** As with the intravascular devices described hereinabove, typically contact between extravascular device **100** and the artery at a given longitudinal location is limited to several (e.g., three to six) contact regions around the circumference of the artery, and is generally minimized. Thus, when the device is placed around the artery there is at least one, and typically a plurality of, non-contact regions **104** around the circumference of the artery, at which the device does not contact the arterial wall. As shown in FIG. 9A, each contiguous non-contact region at a given longitudinal site of the artery, encompasses an angle theta around a longitudinal axis **76** of the artery. For some devices, as shown, the angle theta is also defined by the edges of adjacent contact elements **102** of the device and longitudinal axis **108** of the device. When the device is placed in the artery longitudinal axis **108** of the device is typically aligned with longitudinal axis **76** of the artery.

**[0121]** Typically, angle theta is greater than 10 degrees, e.g., greater than 20 degrees, or greater than 50 degrees. Further typically, angle theta is less than 180 degrees, e.g., less than 90 degrees. For some applications angle theta is 10-180 degrees, e.g., 20-90 degrees. This may be beneficial, since providing contiguous non-contact regions around the artery, as described, allows a greater area of the artery to pulsate in response to pressure changes than if the device were to provide smaller contiguous non-contact regions.

**[0122]** FIG. 9B shows a cross-section of one of contact elements **102** on a wall of artery **20**, in accordance with some applications of the present invention. For some applications, some or all of contact elements **102** are shaped to define grooves. Each of the grooves has a length L. Typically, length L is more than 0.5 mm (e.g., more than 2 mm), and/or less than 8 mm (e.g., less than 6 mm). For example, length L may be 0.5-8 mm, e.g., 2-6 mm. The contact element typically facilitates pulsation of the arterial wall into the groove.

**[0123]** Typically (as shown for example in FIGS. 9A and 9C), extravascular device **100** does not encompass the full circumference of the artery. For example, the extravascular device may encompass less than 90 percent, e.g., less than 70 percent of the circumference of the artery. For some applications, using a device that does not encompass the whole circumference of the artery facilitates placement of the device on the artery. For example, it may be possible to place such a device on the artery (a) without dissecting the artery free from its surrounding tissues, and/or (b) without fully mobilizing the artery.

**[0124]** For some applications, using a device that does not encompass the whole circumference of the artery reduces damage to the artery, and/or damage to baroreceptors, during placement of the device on the artery. Alternatively or additionally, using a device that does not encompass the whole circumference of the artery makes placement of the device on the artery a less complex procedure than placement on the artery of a device that fully encompasses the artery.

**[0125]** For some applications, device **100** does not encompass the whole circumference of the artery, and contact elements **102** curve around the artery, as shown in FIG. 9C. Typically, the curvature of the contact elements facilitates coupling of device **100** to the artery.

**[0126]** Typically, extravascular device **100** encompasses more than 50 percent of the circumference of the artery, for example, in order to prevent the device from slipping from the artery. However, the scope of the present invention includes devices that encompass less than 50 percent of the artery.

**[0127]** For some applications, extravascular device **100** encompasses the whole circumference of artery **20**. For example, an extravascular device may be used that comprises two pieces that are coupled to each other such that the device encompasses the whole artery.

**[0128]** Typically, the device causes an increase in the strain in at least a portion of the arterial wall, relative to the strain in the arterial wall in the absence of the device, without substantially reducing the cross-sectional area of the artery. For example, the cross-sectional area of the artery in the presence of device **100** may be more than 50 percent, e.g., more than 80 percent of the cross-sectional area of the artery in the absence of the device, at a given stage in the subject's cardiac cycle. The device does not cause a substantial reduction in the cross-sectional area of the artery because the device only contacts the artery at discrete points around the circumference of the artery. Therefore the device does not substantially constrict the artery, but rather reshapes the artery relative to the shape of the artery in the absence of the device.

**[0129]** Further typically, the device causes an increase in the strain in at least a portion of the arterial wall, relative to the strain in the arterial wall in the absence of the device, without substantially affecting blood flow through the artery. For example, the rate of blood flow through the artery in the presence of device **100** may be more than 70 percent, e.g., more than 90 percent of the blood flow in the absence of the device.

**[0130]** For some applications, an insubstantial effect on flow is achieved by maintaining an internal diameter of the artery, in the presence of the device, that is at least 30 percent of the diameter of the artery, in the absence of the device, throughout the cardiac cycle. Alternatively or additionally, an insubstantial effect on flow is achieved by maintaining the cross sectional area of the artery, in the presence of the device, to be at least 20 percent of the sectional area, in the absence of the device, at a given stage in the subject's cardiac cycle.

**[0131]** For some applications, the flow through the artery to which the device is coupled is monitored during the implantation of the device, and the device is configured to not reduce the flow by more than 15 percent. For some applications, the degree of force applied to the artery, and/or a physical distance between parts of the device, is modulated until the measured flow is not reduced by more than 15 percent. For some applications the absolute minimal distance across the artery is limited to no less than 1.5 mm.

**[0132]** For some applications, the extravascular devices contact the artery around which they are placed along a length of 5 mm.

**[0133]** For some applications, an extravascular device is used that is in accordance with one or more of the devices

described in U.S. patent application Ser. No. 12/602,787 to Gross, which is incorporated herein by reference.

**[0134]** For some applications, a plurality of extravascular devices **100** are placed around the artery, as shown in FIG. 9D. For some applications, the plurality of extravascular devices are coupled to each other by a coupling element **105**. The extravascular devices are typically spaced from each other such that there are non-contact regions **103** between each of the extravascular devices. Each of the non-contact regions is contiguous and, typically, has a length **L1** of more than 0.5 mm (e.g., more than 2 mm), and/or less than 8 mm (e.g., less than 6 mm). For example, length **L1** may be 0.5-8 mm, e.g., 2-6 mm. The arterial wall is typically able to pulsate at the non-contact regions.

**[0135]** Reference is now made to FIG. 10, which is a graph generated by computer simulation, which indicates the circumferential portion of an arterial wall having a strain that is greater than a threshold value, as a function of the reduction in the cross-sectional area of the artery, for respective extravascular devices. For some applications of the present invention, an extravascular device is placed around an artery, as described hereinabove. Typically, the extravascular device increases strain in at least regions of the arterial wall without substantially reducing the cross-sectional area of the artery, as described hereinabove. Further typically, the extravascular device increases strain in at least regions of the arterial wall without substantially affecting blood flow through the artery, as described hereinabove.

**[0136]** The graph shows several lines, the lines corresponding to extravascular devices that are similar to the extravascular device described hereinabove with reference to FIGS. 3 and 9A. The lines correspond to extravascular devices that have, respectively, three, four, five, six, and seven contact regions with the arterial wall around the circumference of the artery. In addition, one of the lines corresponds to two flat plates that are placed against the outer surface of the artery.

**[0137]** The simulation was generated for an artery at 100 mmHg of pressure. When the extravascular devices herein are placed on the arterial wall, the strain in at least some portions of the arterial wall is increased. Placing the extravascular devices on the arterial wall typically reduces the cross-sectional area of the artery. For a given device, the more the device compresses the artery, the greater the increase in the strain in the arterial walls, and the greater the reduction in the cross-sectional area of the artery.

**[0138]** The x-axis of the graph of FIG. 10 indicates the reduction in the cross-sectional area of the artery generated by the devices. The y-axis measures the percentage of the circumference of the arterial wall having a strain that is at least equivalent to what the strain of the arterial wall would be, if the pressure in the artery were 120 mmHg. Typically, the baroreceptor firing rate in such areas when the pressure is 100 mmHg, during use of the devices described hereinabove, will be generally equivalent to, or greater than the baroreceptor firing rate at 120 mmHg pressure in the absence of use of the devices. Thus, each of the lines in the graph is a measure of the percentage of the circumference of the arterial wall having the increased strain as a function of the reduction in the arterial cross-sectional area that is necessary to induce the increase in strain.

**[0139]** It may be observed that the devices having a smaller number of contact regions with the artery are typically more effective at increasing the strain in the arterial

wall by applying a compression force that does not substantially reduce the cross-sectional area of the artery. For example, devices having three and four contact regions with the artery increase the strain of, respectively, 13 percent and 14 percent of the arterial wall to the equivalent of 120 mmHg of pressure while only reducing the cross-sectional area of the artery by 10 percent. Typically, a 10 percent reduction in the cross-sectional area of the artery does not substantially reduce blood flow through the artery in a manner that has significant adverse physiological effects.

**[0140]** The inventors hypothesize that the devices having a larger number of contact regions with the artery are less effective at increasing the strain in the arterial wall than those with a smaller number of contact regions, because the device acts to support the arterial wall at the contact regions, thereby reducing pulsation of the arterial wall over the course of the cardiac cycle. For this reason, the inventors hypothesize that, at low pressures, the two plates are relatively effective at increasing the strain in the arterial wall, since there is a small amount of contact between the plates and the wall. However, at higher compressive forces, the plates provide more support to the wall since there is a greater contact area between the plates and the wall. Therefore, the plates limit the pulsation of the wall by an increasing amount. At higher compressive forces, the decrease in baroreceptor stimulation due to the reduced pulsation of the artery overrides the increase in baroreceptor stimulation due to the plates exerting pressure on the arterial wall. Thus, at higher compressive forces, the plates are not as effective as the other extravascular devices at increasing the strain in regions of the arterial wall. Nevertheless, the scope of the present invention includes the use of such plates, e.g., when strain increase is not the only parameter of importance in selecting an implant.

**[0141]** It is additionally noted that for a broad range of allowed reductions in cross-section, e.g., about 17-30 percent, 3-6 contact regions all function generally well. Thus, at higher compression forces (i.e., by reducing the cross-sectional area of the artery by a greater amount), the devices having a greater number of contact regions with the artery become more effective at increasing the strain in the arterial wall. For example, by reducing the cross-sectional area of the artery by 30 percent, each of the devices having three to six contact regions with the artery increases the strain of between 22 percent and 26 percent of the arterial wall to the equivalent of 120 mmHg of pressure.

**[0142]** Reference is now made to FIG. 11, which is a graph showing the maximum percentage increase in the strain of the arterial wall as a function of the reduction in the cross-sectional area of the artery, for respective extravascular devices.

**[0143]** The graph shows several lines, the lines corresponding to extravascular devices that are similar to the extravascular device described hereinabove with reference to FIGS. 3 and 9A. The lines correspond to extravascular devices that have, respectively, three, four, five, six, and seven contact regions with the arterial wall around the circumference of the artery. In addition, one of the lines corresponds to two plates that are placed against the outside surface of the artery.

**[0144]** The simulation was generated for an artery at 100 mmHg of pressure. The bottom, middle, and top horizontal lines correspond, respectively, to the maximum strain in the vessel wall at 120 mmHg, 140 mmHg, and 160 mmHg

pressure, when no device is placed on the artery. When the devices herein are placed on the arterial wall, the maximum strain of the arterial wall is increased. Placing the devices on the arterial wall typically reduces the cross-sectional area of the artery. For a given device, the more the device compresses the artery, the greater the maximum strain in the arterial walls, and the greater the reduction in the cross-sectional area of the artery.

**[0145]** The x-axis of the graph of FIG. 11 measures the reduction in the cross-sectional area of the artery generated by the devices. The y-axis measures the maximum strain in the arterial wall.

**[0146]** It may be observed that for the devices for which the data shown in the graph was generated, the fewer the number of contact regions that the device made with the arterial wall, the more effective the device is at increasing the maximum strain in the arterial wall for a given reduction in the cross-sectional area of the artery that is caused by the device. For example, by compressing the artery such that it has a 20 percent reduction in its cross-sectional area:

**[0147]** the device having three contact regions generates a maximum increase of 75 percent in the arterial wall strain,

**[0148]** the device having four contact regions generates a maximum increase of 62 percent in the arterial wall strain,

**[0149]** the device having five contact regions generates a maximum increase of 50 percent in the arterial wall strain,

**[0150]** the device having six contact regions generates a maximum increase of 23 percent in the arterial wall strain, and

**[0151]** the device having seven contact regions generates a maximum increase of less than 5 percent in the arterial wall strain.

**[0152]** Thus, in accordance with some applications of the present invention, extravascular devices having three or more contact regions (e.g., three to six) with the artery are placed around the outside of the artery. The devices typically provide contact regions and non-contact regions of the arterial wall, as described hereinabove. The devices typically increase the strain in the arterial wall, thereby generating increased baroreceptor firing in the artery.

**[0153]** Reference is now made to FIG. 12, which is a schematic illustration of a device 110 that is used to test the baroreceptor response of a subject to a range of intravascular pressures, in accordance with some applications of the present invention. For some applications, before an intravascular device is inserted into a subject's artery, the baroreceptor response of the subject is tested using measuring device 110. Catheter 112 is inserted into artery 20, in which the intravascular device will be implanted. Extendable arms 114 are extendable from the distal end of the catheter, and are configured such that the pressure that the arms exert on the arterial wall increases, as the portion of the arms that extends from the catheter increases.

**[0154]** Extendable arms 114 are extended incrementally from the distal end of the catheter. At each of the increments, the subject's blood pressure is measured in order to determine the baroreceptor response to the pressure that the arms are exerting on the arterial wall. On the basis of the blood pressure measurements, it is determined which intravascular device should be inserted into the subject's artery, and/or what dimensions the intravascular device should have.

**[0155]** For some applications, a measuring device including arms 114 or a similar measuring device is left in place in the artery, but catheter 112 is removed before the blood

pressure measurements are taken. For example, the catheter may be removed in order to increase blood flow through the artery, relative to when the catheter is in place. Once it has been determined, using the measuring device, which intravascular device should be placed inside the artery, and/or what dimensions the intravascular device should have, the measuring device is removed from the artery and the intravascular device is placed inside the artery.

**[0156]** For some applications, a toroid balloon is placed inside the artery and is used as a measuring device. The balloon is inflated incrementally such that the balloon applies varying amounts of pressure to the arterial wall, and the subject's blood pressure is measured in order to measure the response to the pressure being applied to the wall. In this manner, it is determined which intravascular device should be used, and/or what dimensions the intravascular device should have. During the aforementioned measuring procedure, blood continues to flow through the artery, via a central hole in the toroid balloon.

**[0157]** For some applications, the intravascular devices described herein are inserted to an implantation site inside or (using a non-transvascular route) outside of the subject's artery, while the device is in a first configuration thereof. When the device has been placed at the implantation site, the configuration of the device is changed to a second configuration, in which the device is effective to increase baroreceptor stimulation, in accordance with the techniques described herein. For example, the device may be made of nitinol, or another shape memory material, and the configuration of the device may be changed by applying an RF signal, and/or another form of energy, to the device. For some applications, the device is implanted at an implantation site that is close to the subject's skin, and the RF signal is applied to the device via the subject's skin.

**[0158]** For some applications, devices are applied to the carotid artery of a subject who suffers from carotid sinus hypersensitivity, in order to reduce baroreceptor sensitivity of the carotid sinus, by reducing pulsation of the artery. For example, a device may be placed inside or outside the artery such that the device makes contact with the artery at more than six contact points, and/or over more than 180 degrees of the circumference of the artery. For some applications, a device (e.g., a stent) is placed inside or outside of the artery such that the device makes 270-360 degrees of contact with the artery.

**[0159]** Reference is now made to FIG. 13, which is a graph showing blood pressure measured in a dog, before, during and after the bilateral placement of intravascular devices into the dog's carotid sinuses, in accordance with some applications of the present invention. Intravascular devices which made contact with the carotid sinus at four contact regions (the devices being generally as shown in FIGS. 7A-B) were placed in the dog's left and right carotid sinuses. The beginning and end of the implantation period is indicated in FIG. 13 by, respectively, the left and right vertical dashed lines at about five minutes and 153 minutes.

**[0160]** It may be observed that the implantation of the devices in both sinuses resulted in the dog's systolic blood pressure dropping from above 120 mmHg to below 80 mmHg, and in the dog's diastolic blood pressure dropping from about 60 mmHg to about 40 mmHg. During the implantation procedure the dog's blood pressure rose. The inventors hypothesize that the rise in blood pressure is due to catheters blocking the flow of blood to the carotid arteries

during the implantation, resulting in reduced baroreceptor stimulation during the implantation procedure. It is noted that the placement of the device in the dog's sinuses did not have a substantial effect in the dog's heart rate.

[0161] Reference is now made to FIG. 14, which is a graph showing the pressure-strain curve of an artery of a normal subject, a hypertensive subject, and a hypertensive subject who uses one of the devices described herein. One of the causes of hypertension is that the arterial wall of the subject does not experience as much strain at any given pressure, as the arterial wall of a normal subject. Thus, the pressure-strain curve of the hypertensive subject is flattened with respect to that of a healthy subject and the strain response is shifted to higher pressures.

[0162] The devices described herein increase the strain in the arterial wall at all pressure levels within the artery. For some applications, as shown, at increasing arterial pressures, the absolute increase in the strain in the arterial wall caused by the device increases, relative to the strain experienced by the hypertensive subject before implantation of the device. Thus, the devices described herein both shift the pressure-strain curve of a hypertensive subject upwards and increase the gradient of the curve. A device is typically selected such that the subject's pressure-strain curve, subsequent to implantation of the device, will intersect the normal pressure-strain curve at a pressure of between 80 mmHg and 240 mmHg.

[0163] Reference is now made to FIGS. 15A-B, which are schematic illustrations of a device 120 for placing in artery 20, in accordance with some applications of the present invention. Device 120 is generally similar to the intra-arterial devices described hereinabove, except for the differences described hereinbelow. FIG. 15A shows a three-dimensional view of device 120, as the device is shaped when the device is inside the artery, and FIG. 15B shows a flattened, opened, profile of device 120. Device 120 is generally similar to device 80 described hereinabove with reference to FIGS. 7A-B. Device 120 contacts the wall of the artery at four contact regions 122 (which comprise strut portions), thereby flattening the non-contact regions of the artery that are between the contact regions. For some applications, device 120 includes radiopaque markers 126 at proximal and distal ends of the device (as shown) or at other portions of the device.

[0164] As shown in FIG. 15B, each of the strut portions is generally spaced from its two adjacent strut portions by respective distances D1 and D2, D1 being smaller than D2. Thus, the device defines a first set of two sides 124A, having widths D1, and a second set of two sides 124B, having widths D2. Placement of device 120 inside artery 20 typically results in the artery having a cross-sectional shape that is more rectangular than in the absence of the device, the cross-sectional shape having sides with lengths D1 and D2. Each of the sides of the cross-sectional shape is supported by a respective side 124A or 124B of device 120. Typically, the ratio of distance D2 to distance D1 is greater than 1:1, e.g., greater than 2:1, and/or less than 5:1, e.g., between 1.1:1 and 5:1 (e.g., between 1.5:1 and 3:1).

[0165] An experiment was conducted by the inventors of the present application in which a spring constant of a device having generally similar characteristics to device 120 was measured. For the purposes of the experiment, the spring constant of the device was measured by measuring the change in force applied by the device versus the change in

the diameter of the device during cycles of crimping and expansion of the device. A plot of the force versus the diameter of the device during such a cycle forms a hysteresis curve. It is noted that, subsequent to implantation of the device in a subject's artery, the variation in force versus diameter that the device undergoes during a characteristic cardiac cycle also forms a hysteresis curve. When the device is implanted, the maximum force that the device exerts on the arterial wall, which generates the loading branch of the hysteresis curve, is exerted during diastole. The minimum force that the device exerts on the artery, which generates the unloading branch of the hysteresis curve, is exerted during systole. In the experiment that was conducted by the inventors, the spring constant of the device was determined based upon measurements that were performed using an M250-3 CT Materials Testing Machine manufactured by The Testometric Company Ltd. (Lancashire, UK). The device had a spring constant of 1.14 N/mm. In accordance with the aforementioned experimental result, in accordance with some applications of the invention, a device is inserted into a subject's artery in accordance with the techniques described herein, the device having a spring constant of less than 2 N/mm, e.g., less than 1.5 N/mm, or less than 1.3 N/mm.

[0166] Typically, at the distal and proximal ends of device 120, the device is shaped to define crimping arches 125. During transcatheter insertion of the device into the subject's artery, the device is crimped about the crimping arches, such that the span of the device is reduced relative to the span of the device in its expanded state. Upon emerging from the distal end of the catheter, the device expands against the arterial wall.

[0167] For some applications, each crimping arch 125 has a radius of curvature  $r$  that is less than 6 mm (e.g., less than 1 mm), in order to facilitate crimping of device 120 about the crimping arch. For some applications, each crimping arch has a radius of curvature  $r$  that is greater than 0.3 mm, since a crimping arch having a smaller radius of curvature may damage the arterial wall. Furthermore, when the expanded device exerts pressure on the arterial wall, much of the pressure that is exerted on the device by the arterial wall is resisted by the crimping arches. Therefore, for some applications, each crimping arch has a radius of curvature that is greater than 0.3 mm, in order to facilitate resistance to the pressure that is exerted on the device at the crimping arches. Therefore, for some applications, each crimping arch has a radius of curvature that is 0.3-0.6 mm.

[0168] For some applications, the thickness of the struts of device 120 at the crimping arches is greater than the thickness of the struts at other portions of the device, in order to facilitate resistance to the pressure that is exerted on the device at the crimping arches. For some applications, there are additional regions of the struts that are susceptible to absorbing much of the pressure that is exerted on the device by the arterial wall, and the thickness of the struts at the additional regions is greater than the thickness of the struts at other portions of the device.

[0169] Typically, when device 120 is in a non-constrained state thereof, the strut portions of device 120 project outwardly from crimping arch 125 at an angle  $\theta$ , angle  $\theta$  being greater than 30 degrees, e.g., greater than 60 degrees, or greater than 75 degrees. Typically, the outward projection of the struts from the crimping arch at such an angle reduces the moment that the arterial wall exerts about the crimping

arch, relative to if the struts projected outwardly from the crimping arch at a smaller angle. This is demonstrated with reference to FIGS. 15C-D, which show a force  $F$  of the arterial wall being exerted on struts that project outwardly, respectively, at angles of  $\alpha$  and  $\beta$ ,  $\alpha$  being greater than  $\beta$ . In FIG. 15C, the force is exerted on the strut at a distance  $d_1$  from the crimping arch, and in FIG. 15D, the force is exerted on the strut at a distance  $d_2$  from the crimping arch,  $d_1$  being less than  $d_2$ . Therefore, the moment that is exerted about crimping point 125 for the strut shown in FIG. 15C is less than that of FIG. 15D.

[0170] Typically, as a result of angle  $\theta$  being greater than 30 degrees, e.g., greater than 60 degrees, or greater than 75 degrees, when in the non-constrained state, the perimeter of the cross-section of device 120 at any location along the length of the device is more than 80% (e.g., more than 90%) of the maximum perimeter of the cross-section of the device along more than 80% (e.g., more than 90%) of the length of the device. Conversely, if angle  $\theta$  were smaller, the perimeter of the cross-section of device 120 would be more than 80% of the maximum perimeter of the cross-section of the device along less than 80% of the length of the device. It is noted that the perimeter of the cross-section of the device at any location along the length of the device is defined as the line that bounds the solid components (e.g., the struts) of device 120 at the location. This is demonstrated with reference to FIG. 15E, which shows a dotted line indicating the perimeter of the cross-section of the device. Further typically, as a result of angle  $\theta$  being greater than 30 degrees, e.g., greater than 60 degrees, or greater than 75 degrees, the ratio of the perimeter of the cross-section of device 120 to the cross-sectional area of the solid components of the device is more than 80% (e.g., more than 90%) of the maximum value of this ratio along more than 80% (e.g., more than 90%) of the length of the device.

[0171] Reference is now made to FIGS. 16A-D, which are schematic illustrations of another device 130 for placing in artery 20, in accordance with some applications of the present invention. Device 130 is generally similar to the intra-arterial devices described hereinabove, except for the differences described hereinbelow. FIGS. 16B-D show device 130 during the shaping of the device, the device typically being placed on a shaping mandrel 132 during the shaping process. As shown, the cross-sectional shape of intra-arterial device 130 varies along the longitudinal axis of the device. Typically, the device defines strut portions 134, all of which diverge from each other, from a first end of the device to the second end of the device. For some applications, each strut portion includes two or more parallel struts, as described hereinbelow.

[0172] As shown in FIGS. 16C-D, device 130 is shaped such that at the second end of the device, the device has a greater span  $S_2$ , than the span of the device  $S_1$  at the first end of the device. Typically, the ratio of  $S_2$  to  $S_1$  is greater than 1:1, e.g., greater than 1.1:1, and/or less than 2:1, e.g., between 1.1:1 and 2:1 (e.g., between 1.1:1 and 1.4:1).

[0173] For some applications, devices are inserted into a subject's artery that are shaped differently from device 130, but which are also shaped such that at the second end of the device, the device has a greater span  $S_2$ , than the span of the device  $S_1$  at the first end of the device, for example, as described with reference to FIGS. 18A-D.

[0174] Due to the ratio of  $S_2$  to  $S_1$ , upon placement of device 130 inside the artery, the shape of the artery typically

becomes increasingly non-circular (e.g., elliptical or rectangular), along the length of the artery, from the first end of the device (having span  $S_1$ ) to the second end of the device (having span  $S_2$ ). Furthermore, due to the ratio of  $S_2$  to  $S_1$ , upon placement of device 130 inside the artery, the cross-sectional area of the artery typically increases along the length of the artery, from the first end of the device (having span  $S_1$ ) to the second end of the device (having span  $S_2$ ). Typically, the device is placed such that the first end of the device (which has the smaller span) is disposed within the internal carotid artery, and the second end of the device (which has the greater span) is disposed in the vicinity of the carotid bifurcation. In this configuration, the device thus stretches the internal carotid artery in the vicinity of the bifurcation, due to the span of the device at the second end of the device, but does not substantially stretch the internal carotid artery downstream of the bifurcation.

[0175] Typically, the device is shaped such that the device can be viewed as defining three zones along the length of the device. The second end may be viewed as the maximum-span zone, which is configured to be placed in the common carotid artery and/or within the internal carotid artery in the vicinity of the carotid bifurcation. The first end may be viewed as the minimum-span zone, which is configured to be placed at a location within the internal carotid artery that is downstream of the bifurcation and to reduce strain on the internal carotid artery at the downstream location relative to if the minimum-span zone had a greater span. The portion of the device between the first and second zones may be viewed as the pulsation zone, at which the device exerts strain on the artery, while facilitating pulsation of the artery by having non-contact regions at which the device does not contact the artery. It is noted that, for some applications, the second end (i.e., the maximum-span zone) is configured to be placed downstream of the carotid bifurcation, but to cause stretching of the carotid artery in the vicinity of the carotid bifurcation, due to the span of the device at the second end.

[0176] As shown in FIGS. 16C-D, device 130 is shaped such that in the vicinity of the second end of the device, the device has a greater span  $S_2$  in a first direction than a span  $S_3$  of the device in a second direction. For some applications, the ratio of  $S_2$  to  $S_3$  is greater than 1:1, e.g., greater than 2:1, and/or less than 5:1, e.g., between 1.1:1 and 5:1 (e.g., between 1.5:1 and 3:1). Typically, the ratio of  $S_2$  to  $S_3$  enhances flattening of the artery in which device 130 is placed in the direction of span  $S_2$ .

[0177] Typically, device 130 includes three or more diverging strut portions 134, e.g., four diverging strut portions, as shown. For some applications, device 130 includes crimping arches 125 at the ends of the device, the crimping arches being generally similar to crimping arches 125, as described hereinabove with reference to device 120. For some applications, the strut portions of device 130 project outwardly from crimping arches 125 at an angle  $\theta$ , angle  $\theta$  being greater than 30 degrees, e.g., greater than 60 degrees, or greater than 75 degrees, in a generally similar manner to that described with reference to device 120. For some applications, each of the strut portions comprises two struts that are translated longitudinally with respect to one another (i.e., the struts are doubled), in order to provide mechanical strength to the struts. Alternatively, each strut portion includes a single strut, or more than two struts that are translated longitudinally with respect to each other.

[0178] Reference is now made to FIGS. 17A-D, which are schematic illustrations of yet another device 140 for placing in artery 20, in accordance with some applications of the present invention. Device 140 is generally similar to the intra-arterial devices described hereinabove, except for the differences described hereinbelow. FIG. 17A shows device 140 during the shaping of the device, the device typically being placed on shaping mandrel 132 during the shaping process. As shown, the cross-sectional shape of intra-arterial device 140 varies along the longitudinal axis of the device.

[0179] As shown in FIG. 17B, device 140 is shaped such that at the second end of the device, the device has a greater span S2, than the span of the device S1 at the first end of the device. Typically, the ratio of S2 to S1 is greater than 1:1, e.g., e.g., greater than 1.1:1, and/or less than 2:1, e.g., between 1.1:1 and 2:1 (e.g., between 1.1:1 and 1.4:1).

[0180] Due to the ratio of S2 to S1, upon placement of device 140 inside the artery, the shape of the artery typically becomes increasingly non-circular (e.g., elliptical or rectangular), along the length of the artery, from the first end of the device (having span S1) to the second end of the device (having span S2). Furthermore, due to the ratio of S2 to S1, upon placement of device 130 inside the artery, the cross-sectional area of the artery typically increases along the length of the artery, from the first end of the device (having span S1) to the second end of the device (having span S2). Typically, the device is placed such that the second end of the device (which has the greater span) is disposed in the common carotid artery and/or within the internal carotid artery in the vicinity of the carotid bifurcation and the first end of the device (which has the smaller span) is disposed within the internal carotid artery downstream of the bifurcation. In this configuration, the device thus stretches the internal carotid artery in the vicinity of the bifurcation, due to the span of the device at the second end of the device, but does not substantially stretch the internal carotid artery downstream of the bifurcation.

[0181] Device 140 is shaped to define four sides. Two of the sides, which are opposite to one another, are configured to act as artery contact regions 142 (shown in FIG. 17C), and apply pressure to the walls of the artery by contacting the artery. The other two sides of device 140, which are also opposite to one another, are configured to act as crimping regions 144 (shown in FIG. 17D). During transcatheteral implantation of the device into the artery, the crimping regions facilitate crimping of the device.

[0182] It is noted that the sides of device 140 that act as artery contact regions 142 are typically also somewhat crimpable. Typically, as shown, the sides of device 140 that act as artery contact regions 142 include crimping arches 125 (as described hereinabove), which facilitate crimping of the device.

[0183] An artery contacting region 142 of device 140 is shown in FIG. 17C. Upon implantation inside an artery, artery contact regions 142 exert pressure on the artery wall, thereby flattening regions of the arterial wall between the artery contact regions, and increasing the strain in the arterial wall at the flattened regions, as described hereinabove. For some applications, the artery contact regions comprise two or more struts 146 that are translated longitudinally with respect to one another. Typically, the struts of a given artery contact region are coupled to one another by a reinforcing element 148. For some applications, the reinforcing element is disposed such that when the artery contact

region is crimped, the longitudinal translation of the struts with respect to one another is maintained. For some applications, struts 146 of device 140 project outwardly from crimping arches 125 at an angle theta, angle theta being greater than 30 degrees, e.g., greater than 60 degrees, or greater than 75 degrees, in a generally similar manner to that described with reference to device 120.

[0184] A crimping region 144 of device 140 is shown in FIG. 17D. For some applications, crimping region 144 comprises a locking mechanism 149. During crimping of the device, the locking mechanism is unlocked, to facilitate crimping of the device. When the device is implanted into artery 20, the locking mechanism is locked, so as to prevent the crimping regions from becoming crimped due to pressure that is exerted on the device by the artery. For example, the locking mechanism may comprise two struts 150 that are shaped so as to become locked in placed with respect to one another at a locking interface 152. In order to crimp the device, one of the struts is forced above or below the plane of the locking interface. The struts are pre-shaped, such that when the struts are not locked with respect to one another, the struts move toward one another, such that the struts at least partially overlap with one another. Alternatively or additionally, other locking mechanisms are used. For example, a hinged-based mechanism may be used.

[0185] For some applications, device 140 is configured to be at least partially crimpable about the crimping regions even when the device is placed inside the artery. The crimping regions thus facilitate flexing of device 140 when the device is placed inside the artery. For example, the crimping regions may facilitate passive flexing of the device in coordination with the subject's cardiac cycle, due to variations in the pressure that is exerted on the device by the arterial walls, over the course of the cardiac cycle.

[0186] Reference is now made to FIGS. 18A-B, which are schematic illustrations of respective sides 124A and 124B of device 120 for placing in artery 20, in accordance with some applications of the present invention. Device 120 is generally as described hereinabove with reference to FIGS. 15A-B, except that device 120 as shown in FIGS. 18A-B is shaped such that at the second end of the device, the device has a greater span S2, than the span of the device S1 at the first end of the device. Typically, the ratio of S2 to S1 is greater than 1:1, e.g., e.g., greater than 1.1:1, and/or less than 2:1, e.g., between 1.1:1 and 2:1 (e.g., between 1.1:1 and 1.4:1).

[0187] Reference is now made to FIGS. 18C-D, which are schematic illustrations of respective sides 124A and 124B of device 120 for placing in artery 20, in accordance with some applications of the present invention. Device 120 is generally as described hereinabove with reference to FIGS. 15A-B and FIGS. 18A-B, except that device 120 as shown in FIGS. 18C-D is shaped such that (a) sides 124A and 124B are of equal widths, and (b) at the second end of the device, the device has a greater span S2, than the span of the device S1 at the first end of the device. For some applications, a device is used that defines four parallel artery contact regions 122, all of which are separated from adjacent artery contact regions by an equal distance, as shown in FIGS. 18C-D.

[0188] Typically, the ratio of S2 to S1 of device 120 as shown in FIGS. 18C-D is as described hereinabove. Thus, the ratio of S2 to S1 is typically greater than 1:1, e.g., e.g.,

greater than 1.1:1, and/or less than 2:1, e.g., between 1.1:1 and 2:1 (e.g., between 1.1:1 and 1.4:1).

[0189] Reference is now made to FIG. 19, which is a schematic illustration of a D-shaped device 150 for placing inside artery 20, in accordance with some applications of the present invention. For some applications, a device having a D-shaped cross-section, as shown, is placed inside the artery. A straight portion 152 of the cross-sectional shape flattens a portion of the arterial wall that is adjacent to the straight portion, thereby increasing the strain in the portion of the arterial wall relative to the strain in the portion of the arterial wall in the absence of the device.

[0190] It is noted that device 120 and other intra-arterial devices described herein (such as devices 70, 80, and 90) define contact regions that contact the intra-arterial wall, the contact regions comprising a plurality of generally parallel strut portions. Typically, for each of the devices, the minimum distance between a first strut portion of the device and an adjacent strut portion to the first strut portion is 2 mm. It is further noted that the intra-arterial devices described herein (such as devices 60, 70, 80, 90, 120, 130, 140, 150, 170, 174, 176, 190, and/or 200) cause the artery to assume a non-circular cross-sectional shape, such as a triangular, a rectangular, or an oval shape.

[0191] For some applications, the intra-arterial devices described herein (such as devices 60, 70, 80, 90, 120, 130, 140, 150, 170, 174, 176, and/or 190) are configured, upon implantation of the device inside the artery, to cause one or more contiguous portions of the arterial wall to become flattened, each of the contiguous portions having an area of more than 10% of the total surface area of the artery in the region in which the device is placed. Typically, the aforementioned devices contact less than 20 percent (e.g., less than 10 percent) of the wall of the artery along more than 80% of the length of the region of the artery along which the device is placed. As described hereinabove, for some applications, the intravascular devices described herein (such as devices 60, 70, 80, 90, 120, 130, 140, and 150) have a total cross-sectional area of less than 5 sq mm, e.g., less than 0.8 sq mm, or less than 0.5 sq mm. (The total cross-sectional area should be understood to refer to the cross-sectional area of the solid portions of the devices, and not the space in between the solid portions.) The devices typically have this cross-sectional area over a length of the device of more than 4 mm, e.g., more than 6 mm, and/or less than 12 mm, e.g., less than 10 mm. For example, the devices may have the aforementioned cross sectional area over a length of 4 mm-12 mm, e.g., 6 mm-10 mm, or over a length of 10 mm-30 mm.

[0192] For some applications, the dimensions of the intra-arterial devices described herein (such as devices 60, 70, 80, 90, 120, 130, 140, 150, 170, 174, 176, 190, and/or 200) are chosen based upon patient-specific parameters.

[0193] For some applications, the intra-arterial devices described herein (such as devices 60, 70, 80, 90, 120, 130, 140, 150, 170, 174, 176, 190, and/or 200) are made of a shape-memory alloy, such as nitinol. The nitinol is configured to assume an open, deployed configuration at body temperature, and to assume a crimped configuration in response to being heated or cooled to a temperature that differs from body temperature by a given amount, such as by 5 C. In order to insert the device, the device is heated or cooled, so that the device assumes its crimped configuration. The device is placed inside the artery, and upon assuming

body temperature (or a temperature that is similar to body temperature), the device assumes its deployed, open configuration. Subsequently, the device is retrieved from the artery by locally heating or cooling the region of the artery in which the device is disposed. The device assumes its crimped configuration and is retrieved from the artery using a retrieval device. For some applications, a device is inserted into the artery temporarily in order to cause the artery to undergo a permanent shape change. Subsequent to changing the shape of the artery, the device is retrieved from the artery, for example, in accordance with the techniques described above.

[0194] For some applications, the intra-arterial devices described herein (such as devices 60, 70, 80, 90, 120, 130, 140, 150, 170, 174, 176, 190, and/or 200) are configured to expand both radially and longitudinally upon implantation of the device inside the subject's artery.

[0195] For some applications, the intra-arterial devices described herein (such as devices 60, 70, 80, 90, 120, 130, 140, 150, 170, 174, 176, 190, and/or 200) are configured such that, upon implantation of the device inside artery 20, the shape of the device remains substantially the same for the duration of a cardiac cycle of the subject. Alternatively, the device is configured to flex in response to the subject's cardiac cycle. For some applications the device flexes passively, in response to blood pressure changes in the artery. Alternatively or additionally, the device is actively flexed. For example, the device may include a piezoelectric element, and an inductive charged coil (inside or outside of the subject's body), drives the piezoelectric element to flex.

[0196] For some applications, baroreceptors of the subject are activated by driving an electrical current toward the baroreceptors via an intra-arterial device described herein (such as device 60, 70, 80, 90, 120, 130, 140, 150, 170, 174, 176, 190, and/or 200). Thus, the baroreceptors are stimulated both by mechanical shape changes to the artery as a result of the device being placed inside the artery, and via the electrical stimulation of the baroreceptors. For some applications, baroreceptors at least partially adapt to the shape change of the artery due to the placement of intra-arterial device inside the artery, and the baroreceptors fire with a lower firing rate at a given blood pressure, relative to when the device was first implanted. For some applications, in response to the lowered firing rate of the baroreceptors, due to the adaptation of the baroreceptors to the implanted device, electrical stimulation of the baroreceptors is increased.

[0197] Reference is now made to FIG. 20, which is a schematic illustration of intra-arterial device 120, the device including a mesh 160 between artery contact regions 122 of the device, in accordance with some applications of the present invention. For some applications, any one of the intra-arterial devices described herein (such as devices 60, 70, 80, 90, 120, 130, 140, 150, 170, 174, 176, 190, and/or 200) is shaped to define struts, or other artery contact regions, that are configured to change a shape of the arterial wall, by exerting a force on the arterial wall. The device additionally includes a mesh in between the regions that are configured to change the shape of the arterial wall. The mesh is configured not to change the mechanical behavior of the artery (e.g., by changing the shape of the arterial wall), but is configured to prevent strokes caused by embolization of arterial plaque, by stabilizing the arterial plaque, in a generally similar manner to a regular stent. In general, for some

applications, the intra-arterial devices described herein are used to treat hypertension, and are additionally used to treat arterial disease. For some applications, the intra-arterial devices described herein are placed in a subject's carotid artery subsequent to, or during, a carotid endarterectomy procedure.

[0198] Reference is made to FIG. 21, which is a graph showing the derivative of strain versus pressure as a function of rotational position around the artery, in accordance with respective models of an artery, in accordance with some applications of the present invention. The graph shows the derivative of strain versus pressure as a function of rotational position around a quadrant of an artery, for the following four models of the artery:

[0199] 1) A circular elastic artery having no device placed therein, at 150 mmHg.

[0200] 2) An artery having device 120 placed therein, the device causing the artery to assume a rectangular shape. The artery is modeled at a pressure of 150 mmHg. One of the contact points of the device with the artery wall is between 40 and 80 arbitrary units along the x-axis.

[0201] 3) A rectangular artery without a device placed therein, at 80 mmHg. One of the corners of the rectangle is at 40 and 80 arbitrary units along the x-axis. This model of the artery was generated in order to separate the effect of changing the shape of the artery to a rectangular shape from the effect of having a device (such as device 120) placed inside the artery.

[0202] 4) The rectangular artery without a device placed therein, at 150 mmHg.

[0203] The shapes of the curves indicate the following:

[0204] 1) As expected, the derivative of the strain with respect to pressure of the circular, elastic artery is constant due to the elasticity of the artery.

[0205] 2) At the contact point of the intra-arterial device with the artery, the strain-pressure derivative is reduced relative to the rounded artery. At the non-contact regions of the artery, the strain-pressure derivative is also reduced relative to the rounded artery. However, at the non-contact regions, the pressure-strain derivative is still approximately half that of the rounded artery. This indicates that at the non-contact regions, the pulsatility of the artery is reduced, relative to a rounded artery, but that the artery is still substantially pulsatile. Therefore, for some applications, devices are inserted into an artery which re-shape the arterial wall, such that at any longitudinal point along the artery there are non-contact regions at which regions there is no contact between the device and the arterial wall, such that the artery is able to pulsate.

[0206] 3) Based on the two rectangular models of the artery (at 80 mmHg and 150 mmHg), it may be observed that at the straightened regions of the artery (i.e., not at the corner of the rectangle), the strain-pressure derivative of the artery increases at low-pressures (e.g., 80 mmHg), relative to a rounded, elastic artery. At higher pressures (e.g., 150 mmHg), the strain-pressure derivative of the straightened regions of the artery is roughly equal to that of the rounded, elastic artery. This indicates that straightening the wall of the artery, by causing the artery to assume a rectangular or an elliptical shape, may increase the pulsatility of the artery. Therefore, for some applications, devices are inserted into the artery that straighten regions of the arterial wall.

[0207] Reference is now made to FIGS. 22A-C, which are schematic illustrations of a delivery device 160 for placing

an intra-arterial device in the vicinity of a subject's carotid bifurcation, in accordance with some applications of the present invention. For some applications, the intra-arterial devices described herein (such as devices 60, 70, 80, 90, 120, 130, 140, 150, 170, 174, 176, 190, and/or 200) are implanted in the vicinity of a subject's carotid bifurcation, via a delivery device, e.g., delivery device 160. During the implantation of the device, the proximal end of the device is released from the delivery device such that the proximal end of the device is positioned at the start of the bifurcation. Subsequent to the proximal end of the device having been positioned, the distal end of the intravascular device is released from the delivery device. For some applications, prior to releasing the distal end of the device, the effect of the device on baroreceptor firing and/or blood pressure is measured, and the position of the device is adjusted, in response thereto.

[0208] For some applications, delivery device 160 is used to facilitate the above-described implantation procedure. (FIGS. 22A-C show device 120 being implanted inside the artery, by way of illustration and not limitation.) Delivery device 160 includes a retractable sheath 162 at a distal end thereof. During the insertion of the intra-arterial device, the retractable sheath covers the intra-arterial device, as shown in FIG. 22A. The retractable sheath is configured such that, by pulling the sheath proximally, the proximal end of the intra-arterial device is released. Typically, the intra-arterial device is self-expandable. Thus, by releasing the proximal end of the device, the proximal end expands and becomes coupled to the surrounding arterial walls. During the implantation of the device, the proximal end of the device is released from the delivery device, by retracting the retractable sheath, such that the proximal end of the device is positioned at the start of the bifurcation, as shown in FIG. 22B. Subsequent to the proximal end of the device having been positioned, the distal end of the intravascular device is released from the delivery device, by further retracting retractable sheath 162, as shown in FIG. 22C. For some applications, prior to releasing the distal end of the device, the effect of the device on baroreceptor firing is measured, and the position of the device is adjusted, in response thereto.

[0209] Although delivery device 160 has been described as being used to facilitate delivery of an intra-arterial device as described herein, the scope of the present invention includes using delivery device 160 to facilitate the delivery of any intra-arterial device, in a manner that facilitates the release of the proximal end of the intra-arterial device, before the distal end of the intra-arterial device is released. For example, delivery device 160 could be used with a prosthetic valve and/or a stent, such as a bifurcation stent.

[0210] Reference is now made to FIGS. 23A-B, which are schematic illustrations of respective views of a stent-based intra-arterial device 170, in accordance with some applications of the present invention. The views shown in FIGS. 23A and 23B are rotated through 90 degrees about the longitudinal axis of the device, with respect to one another. Device 170 is generally similar to a stent. For example, device 170 is typically cut from nitinol cobalt chrome, and/or stainless steel, such that the device is shaped to define crimpable cells that are defined by struts. However, device 170 typically defines at least one (e.g., two, as shown, or more) non-contact regions 172, at which the device, when placed inside an artery, does not contact the arterial wall.

[0211] Typically, each non-contact region 172 defines a contiguous region in which no struts are disposed. Length L of the device is typically greater than 10 mm (e.g., greater than 40 mm), and/or less than 80 mm (e.g., less than 40 mm). At least one of the non-contact regions has a maximum length l, which is typically greater than 5 mm and/or less than 20 mm. Each of the non-contact regions has a maximum width that defines an arc A that defines an angle of more than 30 degrees, e.g., more than 60 degrees. At locations along the length of the device at which a non-contact region is defined, over a continuous portion of the device having a length that is at least 5 mm, a maximum inter-strut distance d4 defined by any set of two adjacent struts is typically at least 1.5 times (e.g., three times) a maximum inter-strut distance d3 defined by any set of two adjacent struts at locations within 3 mm of the longitudinal ends of the device. Thus, by way of illustration and not limitation, if a maximum inter-strut distance defined by any set of two adjacent struts at locations within 3 mm of the longitudinal ends of the device is 3 mm, then, at locations along the length of the device at which a non-contact region is defined, over a continuous portion of the device having a length that is at least 5 mm, a maximum inter-strut distance defined by any set of two adjacent struts is typically at least 4.5 mm.

[0212] Although non-contact region 172 is shown having a diamond shape, for some applications, non-contact regions of the devices described herein have different shapes, e.g., a square shape, or a rectangular shape. Typically, non-contact region 172 has a non-circular shape. Although non-contact region 172 is shown as being disposed mid-way along the length of device 170, for some applications, non-contact regions of the devices described herein are disposed such that a center of the non-contact region is closer to a proximal end of the device than to a distal end of the device, or vice versa.

[0213] FIGS. 23A-B show device 170 during the shaping of the device, the device typically being placed on a shaping mandrel 172, during the shaping process. For some applications, device 170 is shaped such that at the second end of the device, the device has a span S2 that is greater than span S1 of the device at the first end of the device. Typically, the ratio of S2 to S1 is greater than 1:1, e.g., greater than 1.1:1, and/or less than 2:1, e.g., between 1.1:1 and 2:1 (e.g., between 1.1:1 and 1.4:1).

[0214] Due to the ratio of S2 to S1, upon placement of device 170 inside the artery, the shape of the artery typically becomes increasingly non-circular (e.g., elliptical or rectangular), along the length of the artery, from the first end of the device (having span S1) to the second end of the device (having span S2). Furthermore, due to the ratio of S2 to S1, upon placement of device 170 inside the artery, the cross-sectional area of the artery typically increases along the length of the artery, from the first end of the device (having span S1) to the second end of the device (having span S2). Typically, the device is placed such that the second end of the device (which has the greater span) is disposed in the common carotid artery and/or within the internal carotid artery in the vicinity of the carotid bifurcation, and the first end of the device (which has the smaller span) is disposed within the internal carotid artery, downstream of the bifurcation. In this configuration, the device thus stretches the internal carotid artery in the vicinity of the bifurcation, due to the span of the device at the second end of the device, but

does not substantially stretch the internal carotid artery downstream of the bifurcation.

[0215] Typically, device 170 is shaped such that the device can be viewed as defining three zones along the length of the device. The second end may be viewed as the maximum-span zone, which is configured to be placed in the vicinity of the carotid bifurcation (or downstream of the carotid bifurcation, as described hereinabove) and to stretch the internal carotid artery in the vicinity of the bifurcation. The first end may be viewed as the minimum-span zone, which is configured to be placed at a location within the internal carotid artery downstream of the bifurcation and to reduce strain on the internal carotid artery at the downstream location relative to if the minimum-span zone had a greater span. The portion of the device between the first and second zones may be viewed as the pulsation zone, at which the device exerts strain on the artery, while facilitating pulsation of the artery by defining non-contact regions at which the device does not contact the artery.

[0216] Reference is now made to FIGS. 24A-B, which are schematic illustrations of respective views of stent-based intra-arterial device 170, in accordance with some applications of the present invention. The views shown in FIGS. 24A and 24B are rotated through 90 degrees about the longitudinal axis of the device, with respect to one another. Device 170, as shown in FIGS. 24A-B is generally similar to device 170 as shown in FIGS. 23A-B. For example, device 170 typically defines at least two non-contact regions 172, at which the device, when placed inside an artery, does not contact the arterial wall, which are as described hereinabove. However, whereas device 170 as shown in FIGS. 23A-B is shaped such that span S2, at the second end of the device, is greater than span S1, at the first end of the device, device 170 as shown in FIGS. 24A-B is shaped such that spans S1 and S2 are approximately equal.

[0217] Reference is now made to FIGS. 25A-B, which are schematic illustrations of respective views of stent-based intra-arterial device 174, in accordance with some applications of the present invention. The views shown in FIGS. 25A and 25B are rotated through 90 degrees about the longitudinal axis of the device, with respect to one another. Device 174, shown in FIGS. 25A-B is generally similar to device 170, shown in FIGS. 23A-B. For example, device 174 typically defines at least two non-contact regions 172, at which the device, when placed inside an artery, does not contact the arterial wall, which are as described hereinabove. However, the cells of device 174 are typically larger than those of device 170. For some applications, due to larger cells of device 174 relative to those of device 170, device 174 has a smaller area of metal in contact with the intra-arterial wall when device 174 is placed in the artery than does device 170, when device 170 is placed inside the artery.

[0218] An experiment was conducted by the inventors of the present application in which a spring constant of a device having generally similar characteristics to device 174 was measured. As described hereinabove with reference to FIGS. 15A-B, for the purposes of the experiment, the spring constant of the device was measured by measuring the change in force applied by the device to the artery versus the change in the diameter of the device during cycles of crimping and expansion of the device. The spring constant of the device was determined based upon measurements that were performed using M250-3 CT Materials Testing Machine manufactured by The Testometric Company Ltd.

(Lancashire, UK). The device had a spring constant of 1.5 N/mm. In accordance with the aforementioned experimental result, in accordance with some applications of the invention, a device is inserted into a subject's artery in accordance with the techniques described herein, the device having a spring constant of less than 3 N/mm, e.g., less than 2 N/mm, or less than 1.8 N/mm.

[0219] Reference is now made to FIGS. 26A-B, which are schematic illustrations of respective views of stent-based intra-arterial device 176, in accordance with some applications of the present invention. The views shown in FIGS. 26A and 26B are rotated through 90 degrees about the longitudinal axis of the device, with respect to one another. Device 176 typically defines end portions 177, at which struts are typically disposed evenly around the circumference of the device. Device 176 further defines a central portion 178, which defines one or more (e.g., four, as shown) non-contact regions 172. Non-contact regions 172 are typically generally as described hereinabove. The central portion of the device also defines three or more (e.g., four as shown) struts 179, the struts typically being parallel to each other.

[0220] As described with reference to device 170, shown in FIGS. 23A-B, the length of device 176 is typically greater than 10 mm (e.g., greater than 40 mm), and/or less than 80 mm (e.g., less than 40 mm). At least one of the non-contact regions has a maximum length, which is typically greater than 5 mm and/or less than 20 mm. Each of the non-contact regions has a maximum width that defines an arc A (FIG. 26B) that defines an angle of more than 30 degrees, e.g., more than 60 degrees. At locations along the length of the device at which a non-contact region is defined, over a continuous portion of the device having a length that is at least 5 mm, a maximum inter-strut distance  $d_4$  (FIG. 26A) defined by any set of two adjacent struts is typically at least 1.5 times (e.g., three times) a maximum inter-strut distance  $d_3$  defined by any set of two adjacent struts at locations within 3 mm of the longitudinal ends of the device. Thus, by way of illustration and not limitation, if a maximum inter-strut distance defined by any set of two adjacent struts at locations within 3 mm of the longitudinal ends of the device is 3 mm, then, at locations along the length of the device at which a non-contact region is defined, over a continuous portion of the device having a length that is at least 5 mm, a maximum inter-strut distance defined by any set of two adjacent struts is typically at least 4.5 mm.

[0221] Reference is now made to FIGS. 27A-C, which are schematic illustrations of a stent-based intra-arterial device 190, in accordance with some applications of the present invention. FIG. 27A shows device 190 disposed inside a subject's internal carotid artery 192. Device 190 is generally similar to a stent. For example, device 190 is typically cut from nitinol, cobalt chrome, and/or stainless steel such that the device is shaped to define crimpable cells that are defined by struts. However, device 190 typically defines a non-contact region 191 at which the device does not define any struts. Region 191 is generally similar to non-contact region 172 described hereinabove, except for the differences described hereinbelow.

[0222] As described hereinabove, typically, the intra-arterial devices described herein are implanted in a vicinity of the carotid bifurcation, so as to increase the radius of curvature of the internal carotid artery in the vicinity of the bifurcation, thereby causing increased baroreceptor firing.

For some applications, the devices described herein, when placed in the vicinity of the bifurcation, are placed such that a proximal end of the device is placed within internal carotid artery 192 immediately distal (i.e., downstream) to the carotid bifurcation, and such that the distal end of the device is placed further downstream from the bifurcation. The device is typically placed such that a non-contact region of the device is placed over a region of the internal carotid artery on a side 195 of the internal carotid artery that defines the carotid bifurcation (i.e., the side of the internal carotid artery that is closer to external carotid artery 194). Thus, the device stretches the region of the internal carotid artery, while facilitating pulsation of the region of the internal carotid artery, in accordance with the techniques described hereinabove.

[0223] For some applications, device 190 is placed in the subject's common carotid artery such that a proximal end of the device is placed proximal to (i.e., upstream of) the carotid bifurcation, and such that the distal end of the device is placed within the internal carotid artery downstream of the bifurcation. For such applications, device 190 is typically placed in the common carotid artery such that region 191 is disposed (a) adjacent to the bifurcation of external carotid artery 194 from the common carotid artery, and (b) adjacent to a region of the internal carotid artery on the side of the internal carotid artery that defines the carotid bifurcation (i.e., the side that is closer to the external carotid artery). That is, the device is placed in the carotid artery such that region 191 extends from a location within the common carotid artery that is proximal to the carotid bifurcation until a location within the internal carotid artery that is downstream of the carotid bifurcation. Typically, a maximum length  $l_3$  of region 191 is greater than 15 mm and/or less than 45 mm. Further typically, region 191 defines a maximum width thereof that defines an arc  $A_2$  that defines an angle of more than 30 degrees, e.g., more than 40 degrees.

[0224] Typically, the placement of region 191 adjacent to the bifurcation of the external carotid artery from the common carotid artery facilitates blood flow into the external carotid artery from the common carotid artery, relative to if a portion of a device that defined struts were placed adjacent to the bifurcation (e.g., if a regular stent were placed along the common carotid artery adjacent to the bifurcation of the common carotid artery with the external carotid artery). This is because, since device 190 does not define any struts in region 191, struts of device 190 do not interfere with blood flow through region 191. Furthermore, since device 190 does not define any struts in region 191, there is no build up of matter (e.g., fibrosis) at region 191.

[0225] Typically, the placement of region 191 adjacent to the region of the internal carotid artery on the side of the internal carotid artery that defines the carotid bifurcation (i.e., the side of the internal carotid artery that is closer to the external carotid artery), is such that the device stretches the region of the internal carotid artery, while facilitating pulsation of the region of the internal carotid artery, in accordance with the techniques described hereinabove.

[0226] For some applications, device 190 is shaped to conform with the shape of the common and internal carotid arteries. Thus, for some applications, a first side of device 190 that is configured to be placed in contact with side 195 of the internal carotid artery is shorter than a second side of the device that is opposite the first side. For some applications, all of the cells of the second side of the device are

closed, and at least some of the cells on the first side are open cells, so as to facilitate shortening of the cells of the first side of the device, upon placement of the device inside the artery. Alternatively some of the cells of the second side are also open, but more of the cells of the first side are open than those of the second side. Typically, a maximum length **l2** of device **190** is greater than 20 mm, and/or less than 80 mm.

[0227] It is noted that the devices shown in FIGS. 23A-27C may be defined as having (a) stent-like proximal and distal end portions, and (b) a central portion in between the end portion that defines one or more non-contact regions in which the device does not define any struts, the non-contact region(s) being contiguous regions, having dimensions as described hereinabove. For example, the end portions may be stent-like in that, within the end portions, a maximum distance between any strut and an adjacent strut thereto is less than 5 mm. For some applications, using devices that have stent-like end portions reduces thickening of the arterial wall adjacent to the end portions relative to if devices were used having end portions that define struts that are adjacent to one another and that are at a distance from one another of more than 3 mm. Typically, the stent-based devices described herein are cut from nitinol, and/or a different metal or alloy (such as cobalt chrome, and/or stainless steel). Alternatively, one or more of the stent-based devices described herein are made of braided mesh.

[0228] In general, the devices described herein are typically configured such that the devices define (a) first and second end portions at the proximal and distal end of the device, configured to couple the device to the artery, and (b) a central portion, between the first and second end portions, that defines one or more non-contact regions, configured to increase the radius of a curvature of a portion of the artery adjacent to the non-contact regions while facilitating pulsation of the portion of the artery. The non-contact regions are typically contiguous regions that define no struts having dimensions as described hereinabove. At locations along the length of the device at which a non-contact region is defined, over a continuous portion of the device having a length that is at least 5 mm, a maximum inter-strut distance defined by any set of two adjacent struts is typically at least 1.5 times (e.g., three times) a maximum inter-strut distance  $d3$  defined by any set of two adjacent struts at locations within 3 mm of the longitudinal ends of the device.

[0229] Further typically, the cross-section of the device within 3 mm of the longitudinal ends of the device defines a plurality of dots, corresponding to the struts at the end portions. Similarly, the cross-section of the device at any longitudinal location along the length of the device at which a non-contact region is defined, over a continuous portion of the device having a length that is at least 5 mm, typically defines a plurality of dots, corresponding to the struts at the longitudinal location, the number of dots defined by the cross-section at the longitudinal location typically being less than that of the cross-section of the device within 3 mm of the longitudinal ends of the device. Typically, the minimum angle defined by any set of three of adjacent dots of the cross-section within 3 mm of the longitudinal ends of the device is greater than 150 degrees, and the minimum angle defined by any set of three of adjacent dots of the cross-section at any longitudinal location along the length of the device at which a non-contact region is defined, over a continuous portion of the device having a length that is at least 5 mm, is less than 150 degrees. For example, a ratio of

the minimum angle defined by the cross-section within 3 mm of the longitudinal ends of the device to the minimum angle defined by the cross-section at any longitudinal location along the length of the device at which a non-contact region is defined, over a continuous portion of the device having a length that is at least 5 mm, may be greater than 1.25 (e.g., 2).

[0230] Reference is now made to FIG. 27D, which is a schematic illustration of a stent-based intra-arterial device **200** that defines a C-shaped cross-section, the device defining a non-contact region **202** that runs along the full length of the device, around a given portion of the circumference of the device, in accordance with some applications of the present invention. For some applications, the non-contact region may define an arc about the longitudinal axis of the device that is greater than 30 degrees (e.g., greater than 60 degrees). For some applications, device **200** is placed in the subject's carotid artery (FIG. 27A) such that a proximal end of the device is placed proximal to the carotid bifurcation, and such that the distal end of the device is placed within the internal carotid artery downstream of the carotid bifurcation. For such applications, device **200** is typically placed in the carotid artery such that region **202** is disposed (a) adjacent to the bifurcation of the external carotid artery with the common carotid artery, and (b) adjacent to a region of the internal carotid artery on side **195** of the internal carotid artery that defines the carotid bifurcation (i.e., the side that is closer to the external carotid artery).

[0231] As described hereinabove with reference to device **190**, typically, the placement of region **202** adjacent to the bifurcation facilitates blood flow into the external carotid artery from the common carotid artery, relative to if a portion of a device that defined struts were placed adjacent to the bifurcation (e.g., if a regular stent were placed along the common carotid artery adjacent to the bifurcation of the common carotid artery with the external carotid artery). This is because, since device **200** does not define any struts in region **202**, struts of device **200** do not interfere with blood flow through region **202**. Furthermore, since device **200** does not define any struts in region **202**, there is no build up of matter (e.g., fibrosis) at region **202**.

[0232] Typically, the placement of region **202** adjacent to the region of the internal carotid artery on the side of the internal carotid artery that defines the carotid bifurcation, is such that the device stretches the region of the internal carotid artery, while facilitating pulsation of the region of the internal carotid artery, in accordance with the techniques described hereinabove.

[0233] Reference is now made to FIGS. 28A-C, which are schematic illustrations of cross-sectional views of device **170**, in accordance with some applications of the present invention. Typically, the devices described herein are configured to increase the radius of curvature of the internal carotid artery on side **195** of internal carotid artery **192**, i.e., the side defining the carotid bifurcation. Therefore, devices described herein as defining non-contact regions are typically placed in the carotid artery such that at least one non-contact region (e.g., region **172** of device **170**) is placed adjacent to side **195**. (For some applications, the devices described herein define one or more additional non-contact regions, which are placed adjacent to other regions of the internal carotid artery.) As described hereinabove, for example with reference to FIGS. 15A-B, for some applications, placement of a device inside the artery results in the

artery having a cross-sectional shape that is more rectangular and/or less circular than in the absence of the device. For such applications, the devices are typically placed in the internal carotid artery, such that radius of curvature of side **195** of the internal carotid artery is increased by more than that of the opposite side of the internal carotid artery.

[0234] Some of the stent-like devices described herein (e.g., device **190**, and device **200**) define a single contiguous region that defines no struts and that is configured to be placed adjacent to side **195** of the internal carotid artery. Others of the stent-like devices (such as device **170**, and device **174**) define two regions **172** that are disposed on opposite sides of the device from one another, each of which is contiguous and defines no struts. For some applications, one or more of devices **170**, **174**, and/or **190**, shown in FIGS. **23A-27C**, and/or others of the devices described herein, are configured such that, at least when the device is in a non-constrained state, the device has a cross-sectional shape, such as a rectangular, an elliptical, or a racetrack-shaped cross-sectional shape, that defines a major axis (i.e., a longest axis defined by the cross-sectional shape) and a minor axis (i.e., a shortest axis defined by the cross-sectional shape). The major axis of the cross-section is parallel to the one or two regions of the device that define no struts, and the minor axis of the cross-section is disposed perpendicularly to the one or more regions that define no struts. For example, FIG. **28A** shows device **170** in a non-constrained state thereof. Device **170** defines a racetrack-shaped cross-section, the major axis of the cross-section being parallel to non-contact region **172**, and the minor axis of the cross-section being perpendicular to region **172**. The major axis of the cross-section has a length **14**, and the minor axis has a length **15**. Typically the ratio of **14** to **15** is greater than 1.1:1.

[0235] For some applications, the devices are configured such that, when the device is in a constrained state inside the internal carotid artery, the device assumes a cross-section, such as a square or circular cross-section, in which the major and minor axes become approximately equal, as shown in FIG. **28B**. For example, this may be because the device is more compliant in the direction that is parallel to the non-contact regions than in the direction that is perpendicular to the non-contact regions. Therefore, the device becomes more radially compressed in the direction that is parallel to the non-contact regions than in the direction that is perpendicular to the non-contact regions.

[0236] Alternatively, the devices are configured such that the device maintains a cross-sectional shape that defines major and minor axes, when the device is in the constrained state inside the internal carotid artery, as shown in FIG. **28C**. Thus, the radius of curvature of side **195** of the internal carotid artery is increased by more than the radius of curvature would be increased by a device having a similar cross-section but that is circularly shaped. For some applications, by maintaining the cross-sectional shape that defines major and minor axes inside the artery, the device reduces damage caused to the arterial wall due to discontinuities in the curvature of the wall at edges of the non-contact regions. This is because, the change in the radius of curvature of the artery at the edges of the non-contact region(s) is typically more gradual for a device having a cross-sectional shape that defines major and minor axes (e.g., an elliptical shape or a racetrack-shape), as described, than for that of a device shaped to define a cross-section,

such as a square or circular cross-section, in which the major and minor axes are approximately equal.

[0237] For some applications, compression of the device in the direction that is parallel to the non-contact regions is reduced by forming thickened struts for the struts that are adjacent to the non-contact regions. The thickened struts are configured to provide resistance to the constraining force of the artery on the device that causes the device to become compressed.

[0238] Reference is now made FIG. **29**, which is a schematic illustration of a further intra-arterial device **180**, in accordance with some applications of the present invention. For some applications, intra-arterial device comprises ribs **182** that are disposed on a spine **184**, the ribs being configured to expand into contact with the wall of artery **20**. Typically, ribs **182** are configured to apply a sufficient mechanical force to the wall of the artery to change a shape of the wall. Further typically, the ribs are placed in a vicinity of a baroreceptor (e.g., within the internal carotid artery in the vicinity of the carotid bifurcation), and are configured to change the shape of the wall in the vicinity of the baroreceptor. Typically, device **180** is configured to accommodate pulsation of regions of the walls between the ribs. For some applications, the springiness of the ribs is adjustable, such as by mechanical, electrical, or thermal means (e.g., at least a portion of the rib may comprises nitinol). The springiness may be mechanically adjusted by sliding a portion of the ribs into a chamber such that such the portion is no longer springy. For some applications, the ribs are configured as electrodes, and an electrical signal is applied to the arterial wall via the ribs. For some applications, device **180** is generally similar to electrode device **20** as described with reference to FIG. 3 of WO 07/013065 to Gross, which is incorporated herein by reference.

[0239] Although device **180** is shown in FIG. **29** as having two ribs at each longitudinal location along the device at which the ribs are disposed, for some application, device **180** has more than two, e.g., more than 2, and/or less than 6 ribs at each longitudinal location along the device at which the ribs are disposed.

[0240] Reference is now made to FIG. **30**, which is a schematic illustration of an extra-arterial device **210** configured to be placed around the outside of an artery, in accordance with some applications of the present invention. For some applications, the intra-arterial devices described herein (such as devices **60**, **70**, **80**, **90**, **120**, **130**, **140**, **150**, **170**, **174**, **180**, **190**, and/or **200**) are implanted inside artery **20**, and expand at least a portion of the artery, by applying a force to the arterial wall that is directed radially-outwardly. (FIG. **25** shows device **120** implanted inside the artery, by way of illustration and not limitation.) For some applications, extra-arterial device **210** is placed outside the artery and acts to limit the extent to which the intra-arterial device expands the artery. For example, extra-arterial device **210** may comprise sutures as shown, or a ring that is placed on the outside of the artery.

#### Experimental Data

[0241] A number of experiments were conducted by the inventors in accordance with the techniques described herein.

[0242] In one experiment, acute unilateral carotid stimulation was applied to a first set of dogs, either the left or right carotid sinus of the dogs of the first set being squeezed

between two smooth metal plates for a period of two to five minutes. Acute bilateral carotid stimulation was applied to a second set of dogs, both carotid sinuses of the dogs of the second set being squeezed between two smooth metal plates for a period of 10 to 30 minutes. The mean effect of the unilateral carotid sinus stimulation was to decrease systolic blood pressure by 11 mmHg, and the mean effect of the bilateral stimulation was to decrease systolic blood pressure by 29 mmHg. The results of the bilateral stimulation had a p-value of less than 0.001. These results indicate that using the devices described herein for either unilateral or for bilateral carotid sinus stimulation may be effective at reducing a subject's blood pressure.

[0243] In another experiment, two dogs were chronically implanted (for periods of more than two months) with plates that squeezed the carotid sinus, in accordance with the techniques described herein. The dogs had the plates implanted around both carotid sinuses. On a first one of the dogs, the plates became dislodged from one of the sinuses within two days of implantation. The plates remained implanted around both carotid sinuses of the second dog, until the plates were removed. The blood pressure of the dogs was measured, via an implanted telemeter, for two to four weeks before the device implantation. In the first dog, the dog's blood pressure was measured after the implantation of the device for two weeks, and was subsequently terminated, due to a malfunction in the transmission of the telemeter. In the second dog, the dog's blood pressure was measured for six weeks after the implantation of the device.

[0244] For the dog that had the plates chronically implanted around only one carotid sinus, the average diastolic blood pressure measured in the dog over two weeks post-implantation was 6 mmHg less than the average diastolic blood pressure measured in the dog over two weeks pre-implantation. The average systolic blood pressure measured in the dog over two weeks post-implantation was 8 mmHg less than the average systolic blood pressure measured in the dog over two weeks pre-implantation.

[0245] For the dog that had the plates chronically implanted bilaterally, the average diastolic blood pressure measured in the dog over six weeks post-implantation was 10 mmHg less than the average diastolic blood pressure measured in the dog over two weeks pre-implantation. The average systolic blood pressure measured in the dog over six weeks post-implantation was 18 mmHg less than the average systolic blood pressure measured in the dog over two weeks pre-implantation.

[0246] These results indicate that chronic implantation of the devices described herein for either unilateral or for bilateral carotid sinus stimulation may be effective at chronically reducing a subject's blood pressure.

[0247] In addition to measuring the blood pressure of the dog that had plates chronically implanted bilaterally around its carotid sinuses, the inventors measured the baroreceptor sensitivity of the dog, for several weeks, both pre-implantation and post-implantation of the device using generally similar techniques to those described in "The effect of baroreceptor activity on cardiovascular regulation," by Davos (Hellenic J Cardiol 43: 145-155, 2002), which is incorporated herein by reference. Pre-implantation of the device, the mean baroreceptor sensitivity was  $14 \pm 5$  sec/mmHg. Post-implantation of the device, the mean baroreceptor sensitivity was  $20 \pm 8$  sec/mmHg. These results indi-

cate that chronic implantation of the devices described herein may be effective at increasing baroreceptor sensitivity.

[0248] In a further experiment that was conducted in accordance with the techniques described herein, five human patients had a device placed around either the left or right carotid sinus, subsequent to undergoing endarterectomy procedures. The device was configured to flatten regions of the wall of the carotid sinus, in accordance with techniques described herein. Of the five patients, two were excluded from the study, since these patients were administered atropine, which may have interfered with the results. Of the three patients who were included in the study, the placement of the device in all of the patients resulted in a decrease in both the systolic and diastolic blood pressure of the patient. For the three patients who were included in the study, the placement of the device resulted in a mean decrease in diastolic blood pressure of 8 mmHg (standard deviation 5) and a mean decrease in systolic blood pressure of 22 mmHg (standard deviation 14), relative to the blood pressures before placement of the device. These results indicate that using the devices described herein for carotid sinus stimulation may be effective at reducing a human subject's blood pressure.

[0249] Reference is now made to FIGS. 31A-B, which are graphs showing the herring's nerve firing rate at respective blood pressures recorded in dogs that had been implanted with medical devices, in accordance with some applications of the present invention. Reference is also made to FIGS. 32A-B, which are graphs showing the herring's nerve integrated nerve activity at respective blood pressures recorded in dogs that had been implanted with medical devices, in accordance with some applications of the present invention.

[0250] Four dogs were used in the experiments. In each of the dogs, one femoral artery was accessed with a 6 Fr sheath for the purposes of catheterization, and the contralateral femoral artery was accessed with a 4 Fr sheath, via which invasive blood pressure monitoring was performed. In three out of the four dogs, bilateral vagotomy was performed before the carotid artery was exposed, by complete cutting of the vagus nerve approximately 6 cm caudal to the level of the neck dissection. Unilateral exploration of the neck was directed to the hypoglossal nerve and lingual artery. The hypoglossal nerve and lingual artery were cut such as to expose the plane at which the herring's nerve crosses to join the carotid-cervical ganglion. Following identification of herring's nerve, the nerve was desheathed and divided to micro bundles under a surgical microscope. The nerve bundle was isolated and placed on an electrode.

[0251] The nerve biopotentials at respective blood pressures was recorded (a) on the native, untreated carotid sinus (i.e., baseline recordings), and (b) following implantation in the carotid sinus of either a device that is similar to device 140 (FIGS. 17A-D), or a control stent. Each event recording was initiated at a low blood pressure (e.g., systolic blood pressure of approximately 60 mmHg). The blood pressure was lowered via continuous intravenous infusion of nitroglycerine 1.2 mcg/kg/min. During the event recording, the blood pressure of the dog was gradually raised by continuous intravenous infusion of phenylephrine 150 mcg/kg/min, the dosage of which was gradually increased. When the event recording was completed for the native carotid sinus, a device similar to device 140, or a control stent, was endovascularly implanted in the carotid sinus. An event

recording was performed subsequent to the device implantation, the event recording being as described above. In two of the dogs, subsequent to performing the event recording after the implantation of the first device in the carotid sinus, the other type of device was implanted within the contralateral carotid sinus, and the event recording as described hereinabove was then repeated. All of the dogs were euthanized at the end of the procedures.

[0252] FIG. 31A shows (a) a line that plots the average firing rate of the dogs' herring's nerves during the baseline recordings, in addition to (b) two sets of raw nerve firing rate recordings that were recorded subsequent to the implantation of a device that is similar to device 140 into two of the dogs, and (c) two sets of raw nerve firing rate recordings that were recorded subsequent to the implantation of control stents into two of the dogs. Each of the raw data points in FIG. 31A is based on data averaged over a 1 second running interval. FIG. 31B shows a linear fit of the region of interest of the raw data for each of the experiments. The linear fit assumes that overall shape of the curve is sigmoid, and that the region of interest is in the sloped region of the sigmoid. The flat portions at pressures above and below the region of interest were assumed to be saturation regions, the effect of the implanted devices being limited within these regions. In all cases, the transition from the flat portion of the sigmoid to the linear slope was assumed to be at approximately 100 mmHg. For the device indicated as device 140-2 in FIGS. 31A-D, it was assumed that at pressures above 140 mmHg, the effect of the device was saturated, and the data corresponding to this region were not used in the generation of the linear fit line for this device. For all other event recordings, it was assumed that the upper saturation region was not reached within the blood pressure range that was generated during the experiment. It is noted that the size of the device indicated as device 140-2 in FIGS. 31A-D was too small for the carotid sinus in which the device was implanted. This may be the reason why the response curve for this device appears to have an upper saturation region from a pressure of approximately 140 mmHg.

[0253] It is noted that there was a discontinuity in the data recorded during the event recording for the device indicated by control stent-2 in FIGS. 31A-D. The experiment that was conducted with control stent-2 was prolonged due to technical issues, which caused increased bleeding of the animal. This gave rise to electronic noise that was captured by the electrodes and which caused a discontinuity in the data. The discontinuity was corrected for in the data plotted in FIGS. 31A-D.

[0254] It is noted that experimental data for one of the dogs are not shown. This is because one of the dogs did not undergo a vagotomy. Therefore, the administration of nitroglycerine and phenylephrine to the dog (which was performed in order to induce changes in the dog's blood pressure, as described above) did not substantially affect the dog's blood pressure. The experimental results from this dog are not included in the data shown in FIGS. 31A-D.

[0255] In addition, in a second one of the four dogs, only the control stent deployed correctly, and in a third one of the dogs, only the device that was similar to device 140 was deployed due to difficulties in locating the nerve innervating the carotid sinus on the dog. Therefore, for the second dog, experimental results for the device that was similar to device 140 are not included in the data shown in FIGS. 31A-D, and,

for the third dog, experimental results for the control stent are not included in the data shown in FIGS. 31A-D.

[0256] FIGS. 31C-D are generally similar to FIGS. 31A-B respectively but show the integrated nerve activity recorded in the dogs' herring's nerves during the events, rather than the nerve firing rates.

[0257] As indicated in FIGS. 31A-D, the effect of the implantation of both device 140 and the control stent in the dogs' carotid sinuses resulted in a shift of the response curve of the herring's nerve to lower pressures. This is because, at all blood pressures, the implanted devices increase nerve activity by deforming the carotid sinus, thereby increasing baroreceptor stimulation. The shift in the response curve resulting from the implantation of device 140 is greater than that resulting from the implantation of the control stents. In addition, the shapes of the response curves indicate that implantation of device 140 resulted in a steeper nerve response curve than the response curve that resulted from the implantation of the control stents. The shape of the response curve resulting from the implantation of device 140 is similar in shape to the shape of the baseline curve.

[0258] The results shown in FIGS. 31A-D indicate that the devices described herein are effective at (a) shifting the baroreceptor response curve of a subject toward lower blood pressures, without (b) substantially impairing (and possibly improving) the responsiveness of the baroreceptors to changes in blood pressure. The inventors hypothesize that the implantation of the devices described herein do not substantially impair, and may even improve, the responsiveness of the baroreceptors to changes in blood pressure, since the devices are shaped such as to maintain pulsatility of the carotid artery, subsequent to implantation of the devices inside the carotid artery. The inventors hypothesize that by maintaining the natural arterial baroreceptor response curve, the devices described herein may prevent long-term resetting of the responsiveness of the baroreceptors subsequent to device implantation. Alternatively, it is possible that in the experiments described with reference to FIGS. 31A-D, the devices activated the high pressure c-fibers which are not normally activated and do not reset.

[0259] The scope of the present invention includes combining the apparatus and methods described herein with those described in US 2008/0033501 to Gross, WO 10/035271 to Gross, US 2011/0213408 to Gross, US 2011/0077729 to Gross, and/or US 2011/0178416 to Gross, all of which applications are incorporated herein by reference.

[0260] It will be appreciated by persons skilled in the art that the present invention is not limited to what has been particularly shown and described hereinabove. Rather, the scope of the present invention includes both combinations and subcombinations of the various features described hereinabove, as well as variations and modifications thereof that are not in the prior art, which would occur to persons skilled in the art upon reading the foregoing description.

What is claimed is:

1. Apparatus comprising:

an implantable device having first and second longitudinal ends, the device having a length of less than 80 mm when the device is unconstrained;

the device comprising struts, arranged such that, when the device is unconstrained, along a continuous portion of the device having a length that is at least 5 mm, a maximum inter-strut distance defined by any set of two adjacent struts is more than 1.5 times as great as a

- maximum inter-strut distance defined by any set of two adjacent struts within longitudinal portions of the device within 3 mm of the longitudinal ends of the device.
2. The apparatus according to claim 1, wherein the device is configured to lower blood pressure of a patient, by being implanted proximate to a baroreceptor within an artery of the subject.
3. The apparatus according to claim 2, wherein the continuous portion of the device comprises a portion of a region of the device that defines no struts, the region having a non-circular shape.
4. The apparatus according to claim 2, wherein the continuous portion of the device comprises a portion of a region of the device that defines no struts, a center of the region being disposed asymmetrically with respect to a length of the device.
5. The apparatus according to claim 2, wherein along the continuous portion of the device, the maximum inter-strut distance defined by any set of two adjacent struts is more than 3 times as great as the maximum inter-strut distance defined by any set of two adjacent struts within longitudinal portions of the device within 3 mm of the longitudinal ends of the device.
6. The apparatus according to claim 2, wherein the device has a length of less than 50 mm.
7. The apparatus according to claim 1, wherein the device has a spring constant of less than 2 N/mm.
8. The apparatus according to claim 7, wherein the device has a spring constant of less than 1.5 N/mm.
9. The apparatus according to claim 1, wherein along the continuous portion of the device, the maximum inter-strut distance defines an arc of more than 30 degrees around a longitudinal axis of the device.
10. The apparatus according to claim 9, wherein along the continuous portion of the device, the maximum inter-strut distance defines an arc of more than 60 degrees around the longitudinal axis of the device.
11. The apparatus according to claim 1, wherein within the longitudinal portions of the device within 3 mm of the longitudinal ends of the device the struts define angles therebetween, wherein within the continuous portion the struts define angles therebetween, and wherein a minimum angle defined by the struts within the longitudinal portions of the device within 3 mm of the longitudinal ends of the device is greater than a minimum angle defined by the struts within the continuous portion.
12. The apparatus according to claim 11, wherein a ratio of the minimum angle defined by the struts within the longitudinal portions of the device within 3 mm of the longitudinal ends of the device to the minimum angle defined by the struts within the continuous portion is greater than 1.25.
13. The apparatus according to claim 12, wherein the ratio of the minimum angle defined by the struts within the longitudinal portions of the device within 3 mm of the longitudinal ends of the device to the minimum angle defined by the struts within the continuous portion is greater than 2.
14. Apparatus comprising:  
an implantable device that is shaped to define struts arranged such that, when the device is unconstrained, along a continuous portion of the device having a length that is at least 5 mm, a maximum inter-strut distance defined by any set of two adjacent struts is more than 5 mm,  
the implantable device having a length of less than 80 mm when the device is unconstrained,  
the implantable device, at any location along the length of the device, defining a ratio of a perimeter of a cross-section of the device at the location to the cross-sectional area defined by the struts of the device at the longitudinal location, and  
the implantable device defining a maximum value of said ratio,  
the ratio being more than 80 percent of the maximum value of the ratio along more than 80 percent of a length of the device.
15. The apparatus according to claim 14, wherein the device is configured to lower blood pressure of a patient, by being implanted proximate to a baroreceptor within an artery of the subject.
16. The apparatus according to claim 15, wherein the continuous portion of the device comprises a portion of a region of the device that defines no struts, the region having a non-circular shape.
17. The apparatus according to claim 15, wherein the continuous portion of the device comprises a portion of a region of the device that defines no struts, a center of the region being disposed asymmetrically with respect to a length of the device.
18. The apparatus according to claim 15, wherein the device has a length of less than 50 mm.
19. The apparatus according to claim 14, wherein the device has a spring constant of less than 2 N/mm.
20. The apparatus according to claim 19, wherein the device has a spring constant of less than 1.5 N/mm.
21. The apparatus according to claim 14, wherein along the continuous portion of the device, the maximum inter-strut distance defines an arc of more than 30 degrees around a longitudinal axis of the device.
22. The apparatus according to claim 21, wherein along the continuous portion of the device, the maximum inter-strut distance defines an arc of more than 60 degrees around the longitudinal axis of the device.
23. The apparatus according to claim 14, wherein along the continuous portion of the device, the maximum inter-strut distance defined by any set of two adjacent struts is more than 1.5 times as great as a maximum inter-strut distance defined by any set of two adjacent struts within longitudinal portions of the device within 3 mm of longitudinal ends of the device.
24. The apparatus according to claim 23, wherein along the continuous portion of the device, the maximum inter-strut distance defined by any set of two adjacent struts is more than 3 times as great as the maximum inter-strut distance defined by any set of two adjacent struts within the longitudinal portions of the device within 3 mm of longitudinal ends of the device.
25. Apparatus comprising:  
an implantable device that is shaped to define struts, the device being shaped such that over a continuous portion of the device having a length that is at least 5 mm, the device defines at least one circumferential region in which no struts are disposed, the region defining an arc of at least 30 degrees around a longitudinal axis of the device,

a cross-sectional shape of the device at the region being shaped to define a major axis and a minor axis, at least when the device is in a non-constrained state thereof, a major axis of the cross-sectional shape being parallel to a plane defined by the region in which no struts are disposed, and a minor axis of the cross-sectional shape being perpendicular to the plane.

**26.** The apparatus according to claim **25**, wherein the device is configured to lower blood pressure of a patient, by being implanted proximate to a baroreceptor within an artery of the subject.

**27.** The apparatus according to claim **26**, wherein the region defines an arc of at least 60 degrees around the longitudinal axis of the device.

\* \* \* \* \*

专利名称(译)	用于控制血压的装置和方法		
公开(公告)号	<a href="#">US20170196713A1</a>	公开(公告)日	2017-07-13
申请号	US15/473116	申请日	2017-03-29
[标]申请(专利权)人(译)	血管动力学		
申请(专利权)人(译)	血管动力学, INC.		
当前申请(专利权)人(译)	血管动力学, INC.		
[标]发明人	GROSS YOSSI AVNERI ITZIK WEISBERG ORI ESHKOL MOSHE OREN TAL ASSAF YARON FELD TANHUM ELAZAR MOSHE		
发明人	GROSS, YOSSI AVNERI, ITZIK WEISBERG, ORI ESHKOL, MOSHE OREN, TAL ASSAF, YARON FELD, TANHUM ELAZAR, MOSHE		
IPC分类号	A61F2/82 A61B5/00 A61F2/90 A61B5/0215 A61F2/856		
CPC分类号	A61F2/82 A61B5/0215 A61F2230/0069 A61F2/90 A61B5/0053 A61F2/856 A61F2/06 A61F2/915 A61F2230/0021 A61F2250/0059		
优先权	60/702491 2005-07-25 US 61/194339 2008-09-26 US 60/721728 2005-09-28 US		
外部链接	<a href="#">Espacenet</a> <a href="#">USPTO</a>		

摘要(译)

描述了包括具有第一和第二纵向末端的可植入装置的装置和方法，当装置不受约束时，该装置具有小于80mm的长度。该装置包括支柱，其布置成使得当装置不受约束时，沿着装置的连续部分具有至少5mm的长度，由任何一组两个相邻支柱限定的最大支柱间距大于1.5倍在装置的纵向端部3mm内，由装置的纵向部分内的任何一组两个相邻支柱限定的最大支柱间距。还描述了其他应用。

