



(19) **United States**

(12) **Patent Application Publication**  
**LIN et al.**

(10) **Pub. No.: US 2016/0374622 A1**  
(43) **Pub. Date: Dec. 29, 2016**

(54) **RANDOM BODY MOVEMENT  
CANCELLATION FOR NON-CONTACT  
VITAL SIGN DETECTION**

*G06F 17/14* (2006.01)  
*G06F 19/00* (2006.01)

(52) **U.S. CI.**  
CPC ..... *A61B 5/7214* (2013.01); *G06F 17/14*  
(2013.01); *G06F 19/3418* (2013.01); *A61B*  
*5/7278* (2013.01); *A61B 5/0205* (2013.01);  
*A61B 5/742* (2013.01); *A61B 5/6823*  
(2013.01); *A61B 5/05* (2013.01); *A61B 5/024*  
(2013.01)

(71) Applicant: **University of Florida Research  
Foundation, Inc.**, Gainesville, FL (US)

(72) Inventors: **JENSHAN LIN**, GAINESVILLE, FL  
(US); **CHANGZHI LI**, LUBBOCK,  
TX (US); **YA-CHI LIU**, DOUILLOU  
(US)

(21) Appl. No.: **15/259,580**

(22) Filed: **Sep. 8, 2016**

**Related U.S. Application Data**

(63) Continuation of application No. 14/276,300, filed on  
May 13, 2014, now Pat. No. 9,477,812, which is a  
continuation of application No. 12/668,700, filed on  
Jan. 12, 2010, now Pat. No. 8,721,554, filed as  
application No. PCT/US08/69766 on Jul. 11, 2008.  
(60) Provisional application No. 60/949,285, filed on Jul.  
12, 2007.

**Publication Classification**

(51) **Int. Cl.**  
*A61B 5/00* (2006.01)  
*A61B 5/05* (2006.01)  
*A61B 5/0205* (2006.01)

(57) **ABSTRACT**

A method and system for cancelling body movement effect for non-contact vital sign detection is described. The method begins with sending on a first electromagnetic wave transceiver a first electromagnetic signal with a first frequency to a first side of a body, such as a person or animal. Simultaneously using a second electromagnetic wave transceiver a second electromagnetic signal is sent with a second frequency to a second side of a body, wherein the first frequency and the second frequency are different frequencies. A first reflected electromagnetic signal reflected back in response to the first electromagnetic wave on the first transceiver is received and a first baseband complex signal is extracted. Likewise a second reflected electromagnetic signal reflected back in response to the second electromagnetic wave on the second transceiver is received and a second baseband complex signal is extracted. The first baseband complex signal is mathematically combined with the second baseband complex signal to cancel out a Doppler frequency drift therebetween to yield a periodic Doppler phase effect.

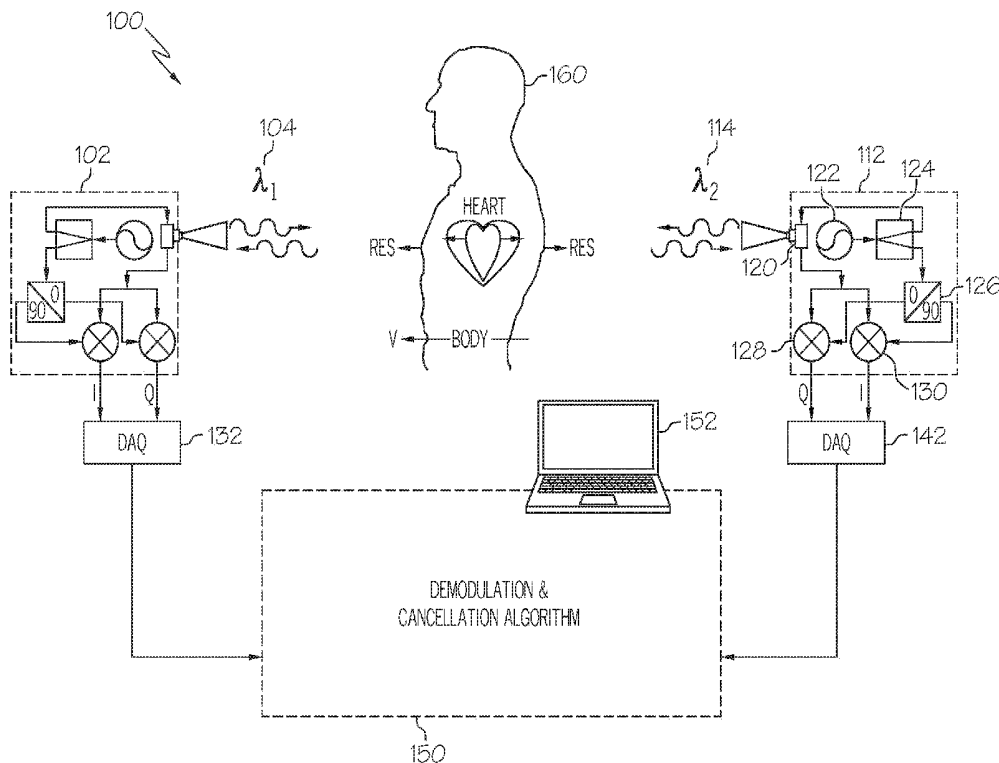

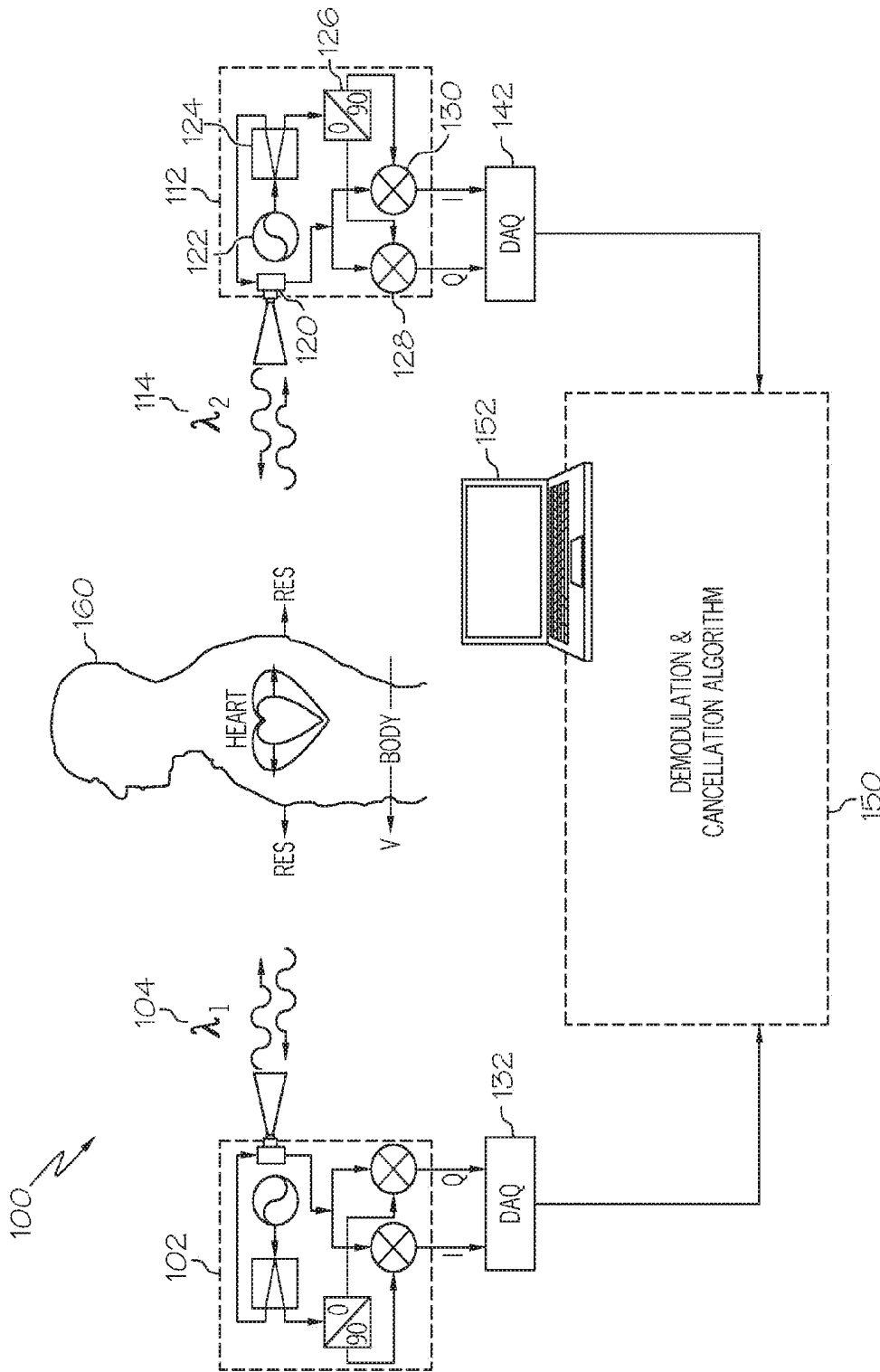

FIG. 1

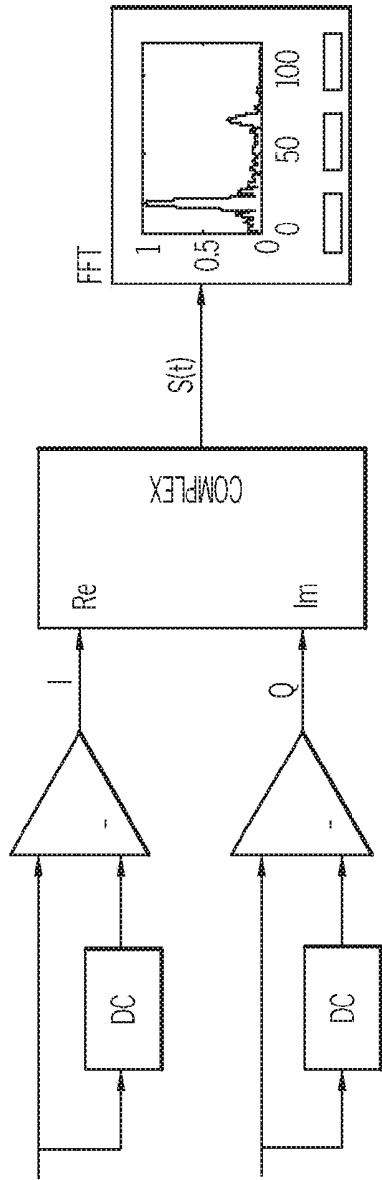

FIG. 2A

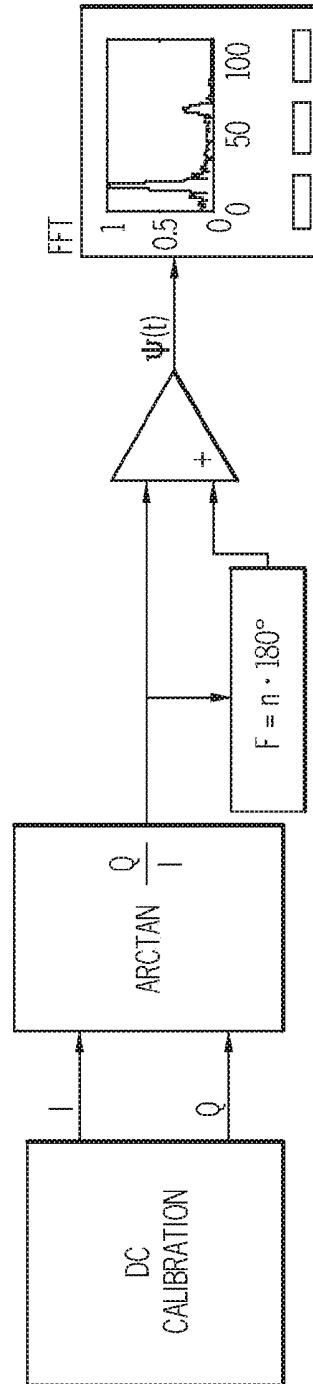
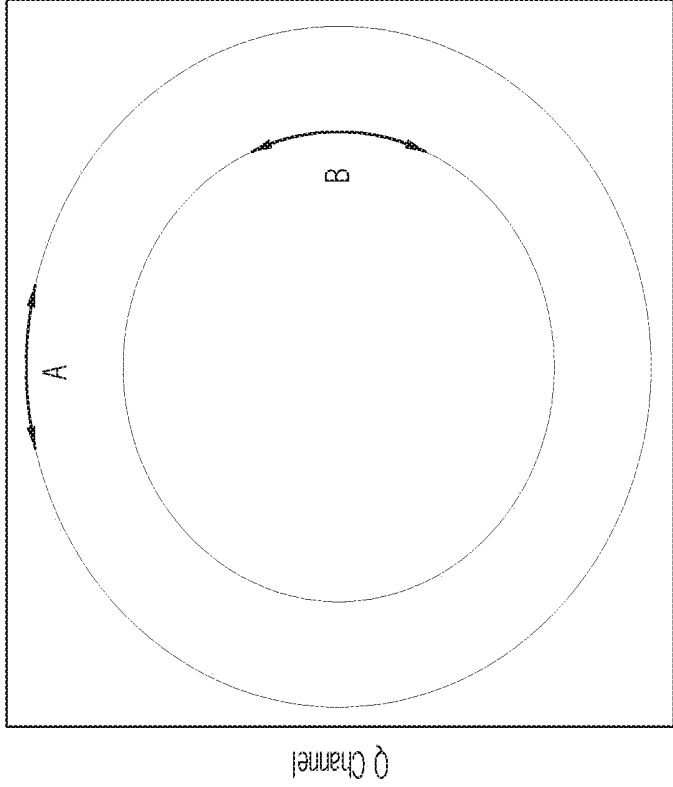

FIG. 2B



I Channel

FIG. 3B

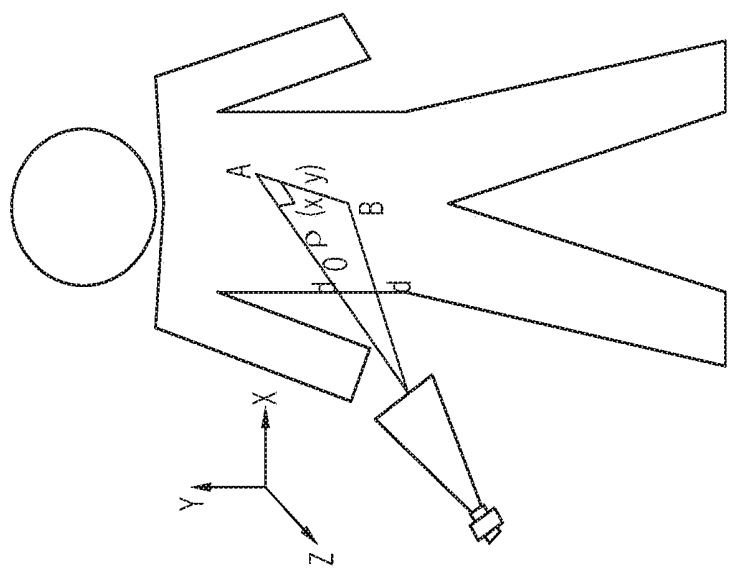

FIG. 3A

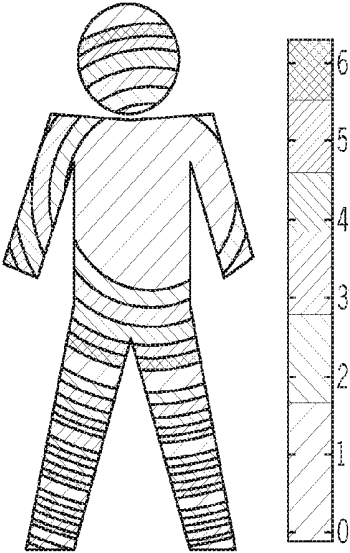

FIG. 4A

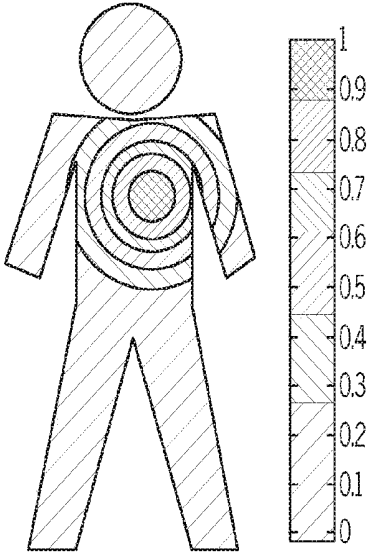

FIG. 4B

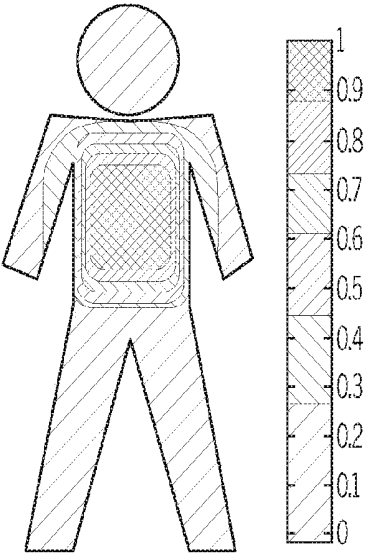

FIG. 4C

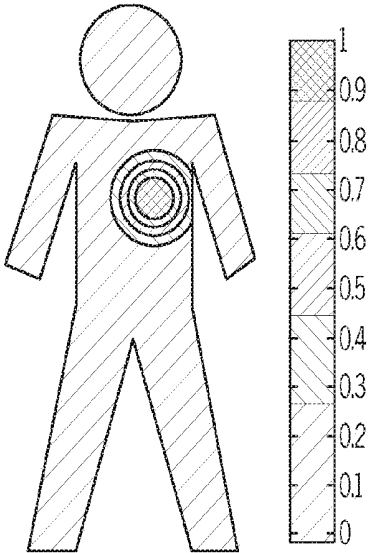

FIG. 4D

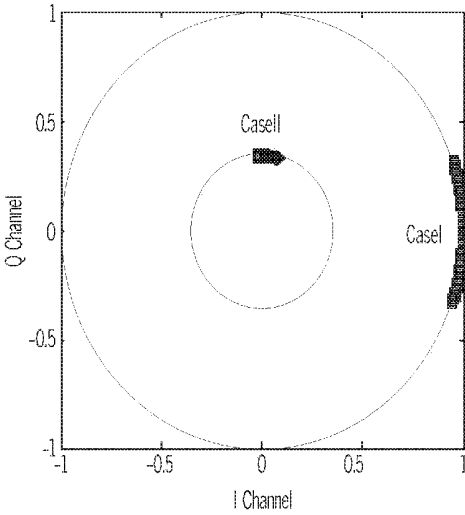

FIG. 5A

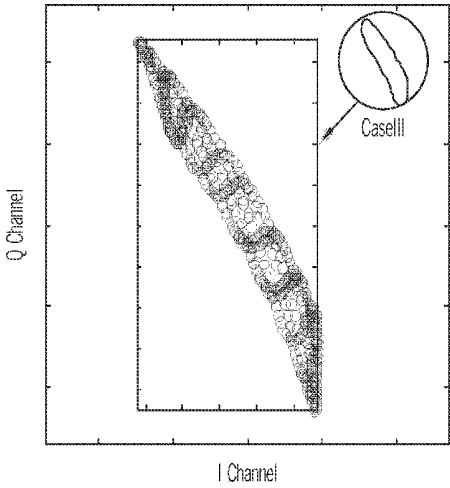

FIG. 5B

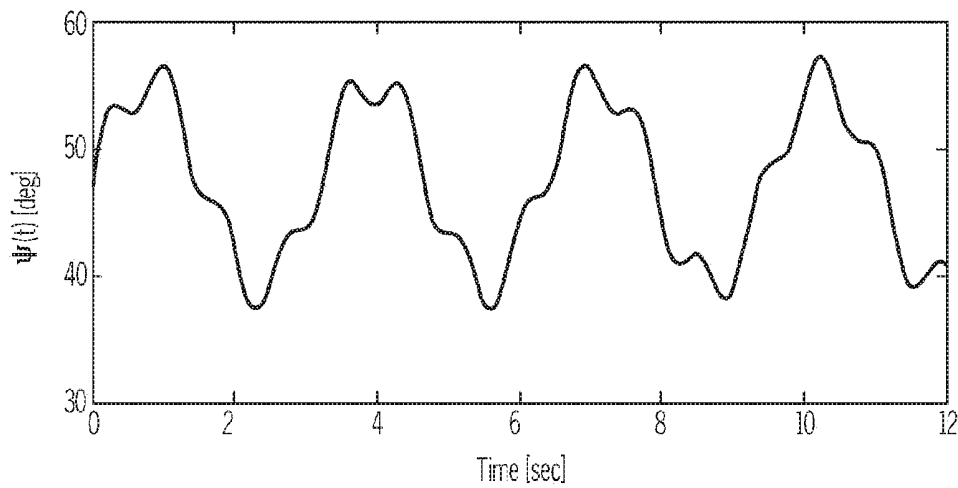

FIG. 5C

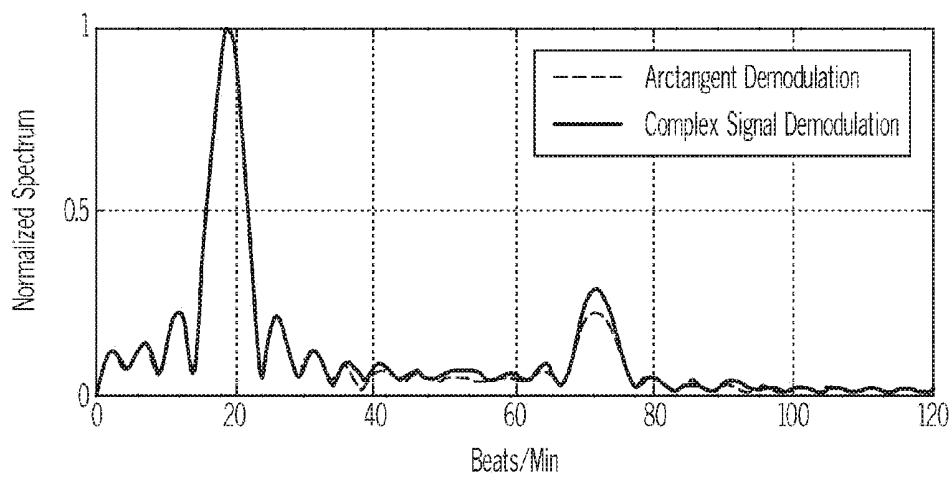

FIG. 5D

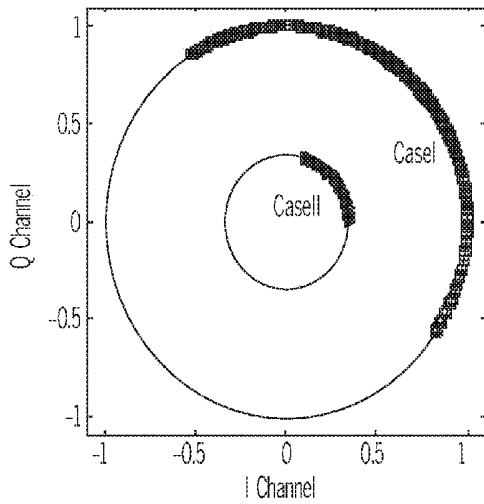

FIG. 6A

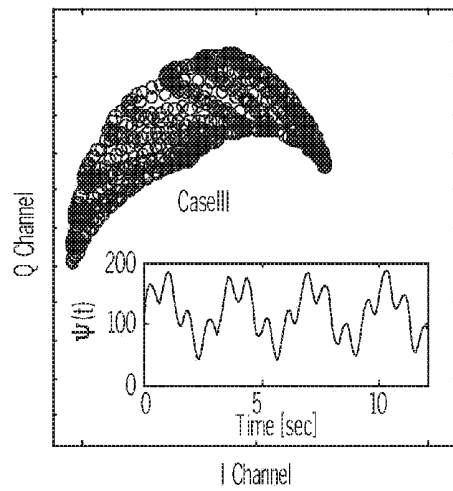

FIG. 6B

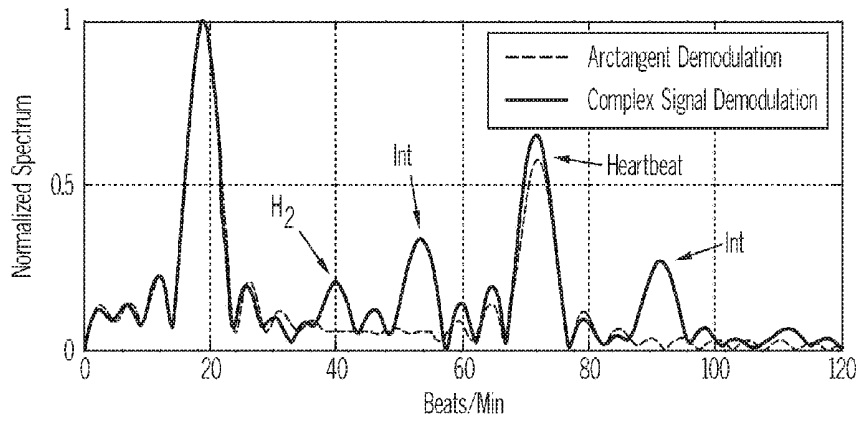

FIG. 6C

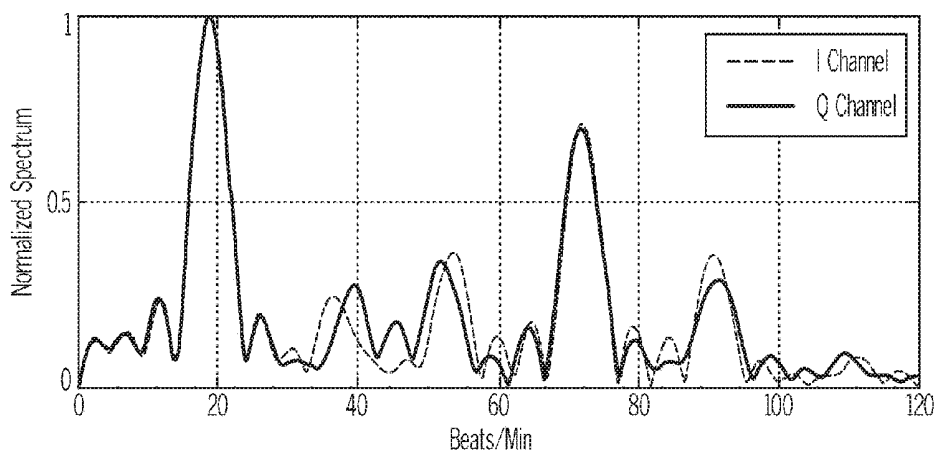

FIG. 7A

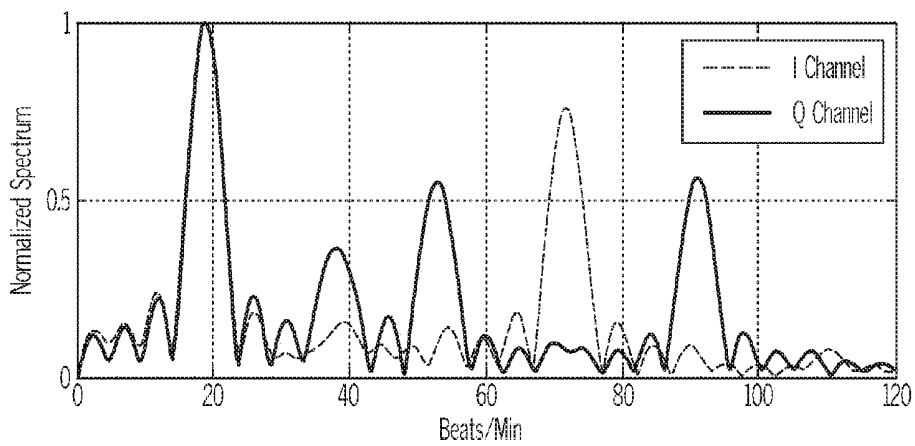

FIG. 7B

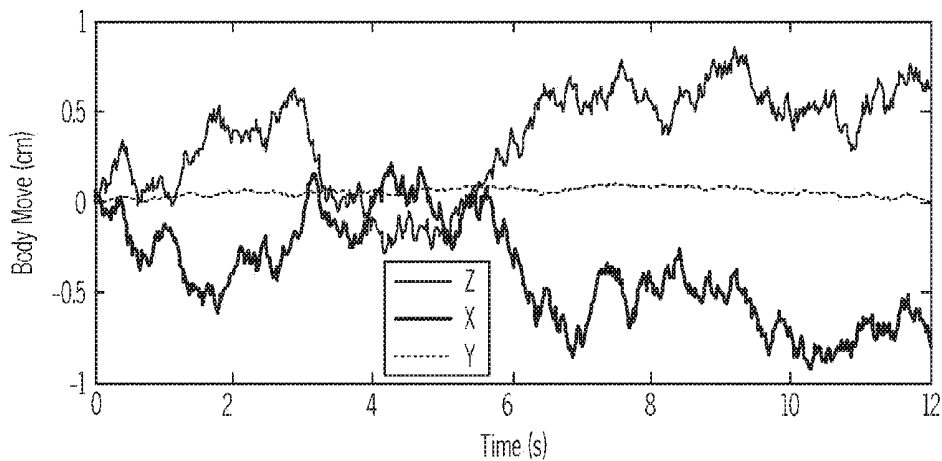

FIG. 8A

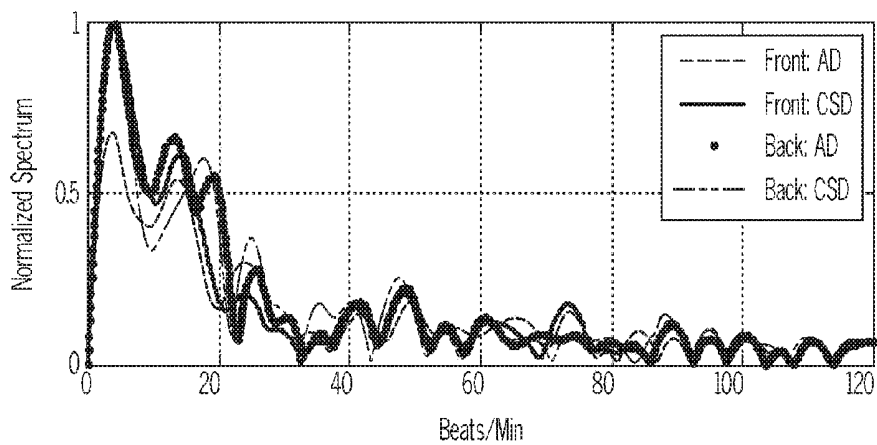

FIG. 8B

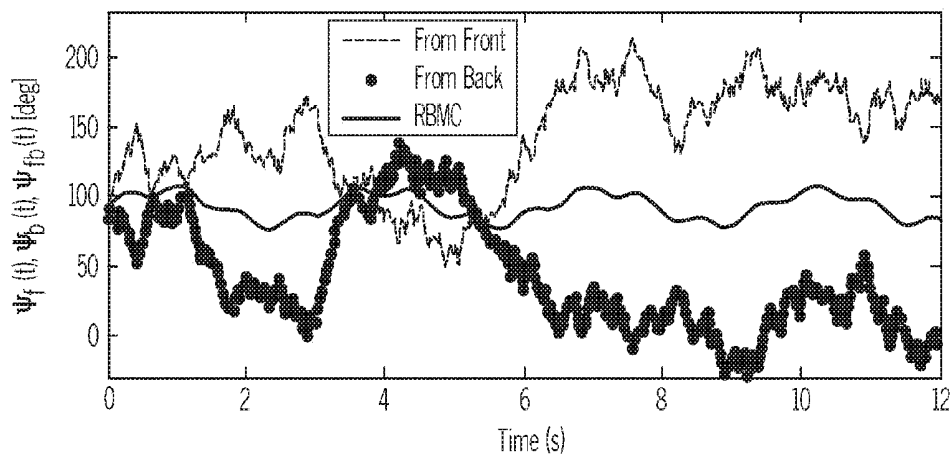

FIG. 9A

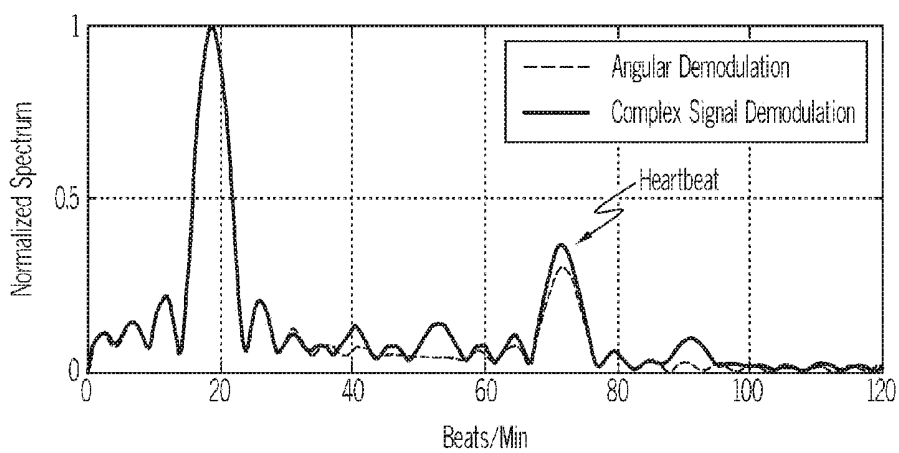

FIG. 9B

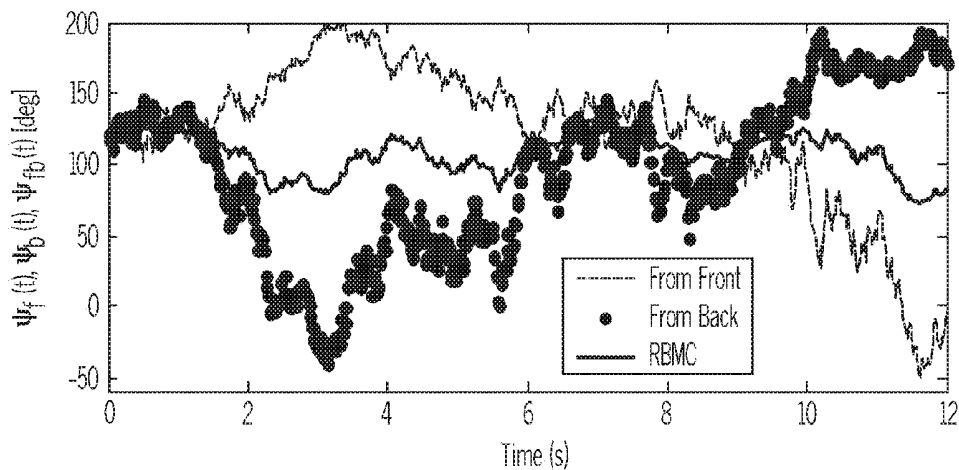

FIG. 10A

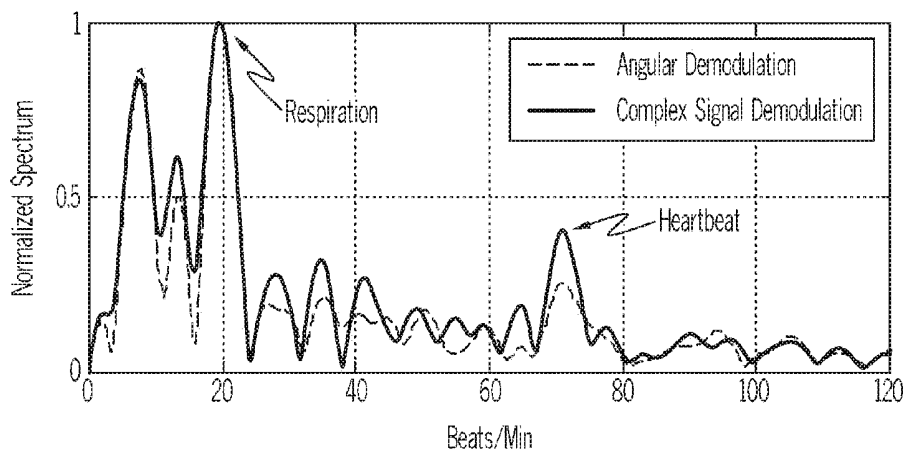

FIG. 10B

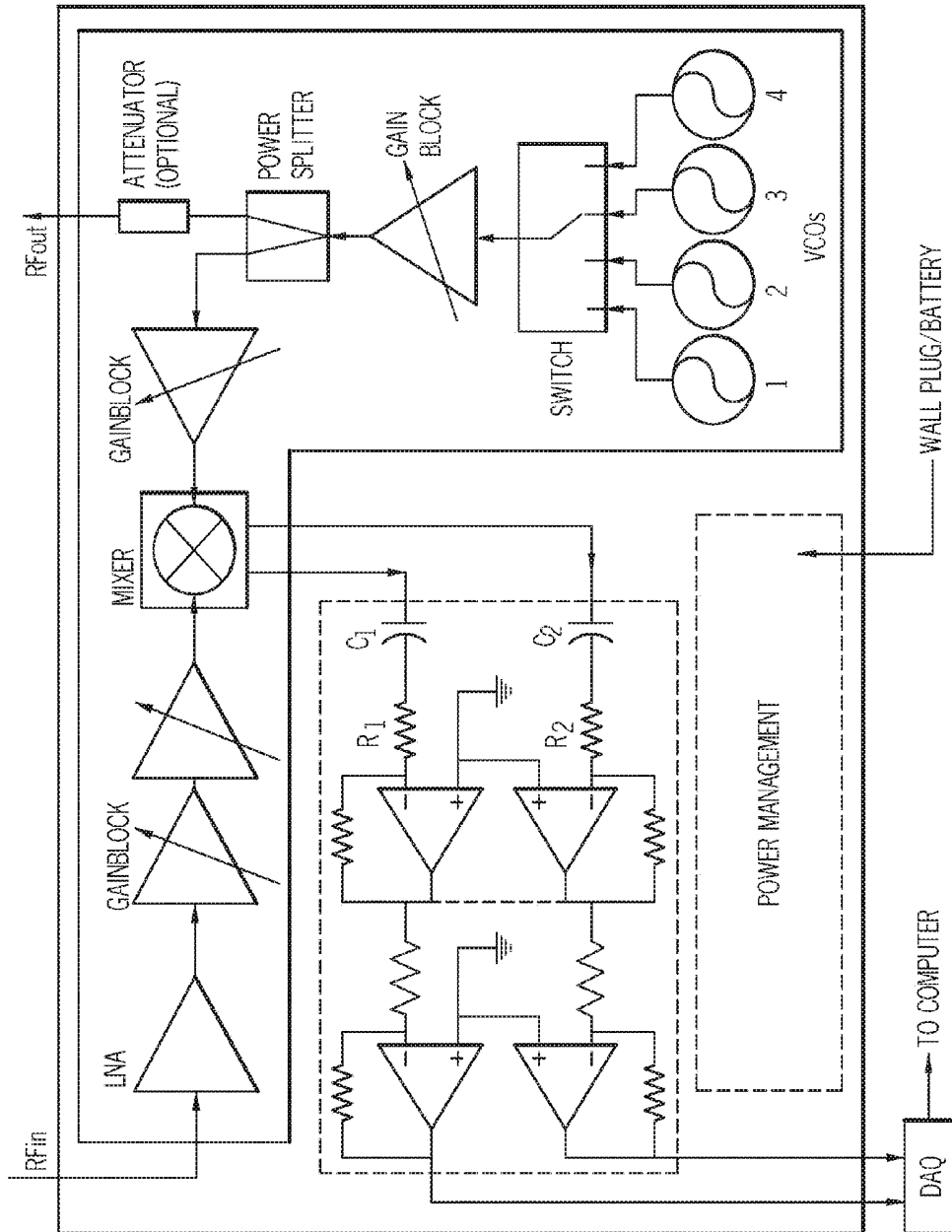

FIG. 11

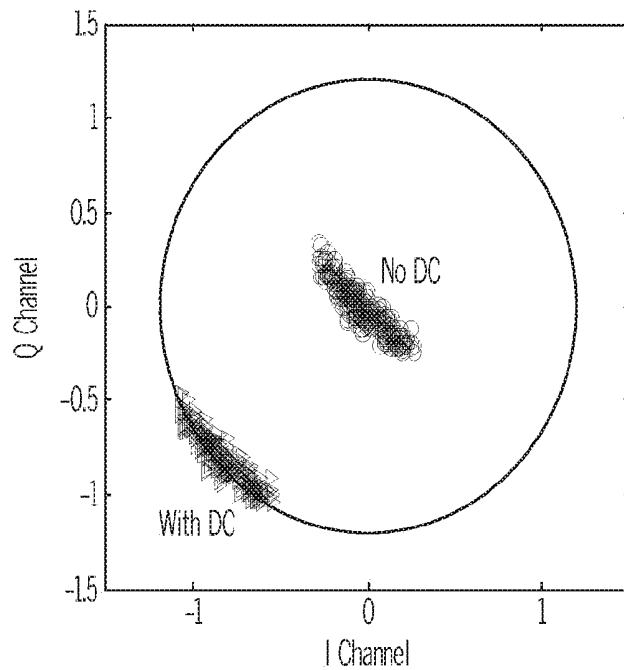

FIG. 12A

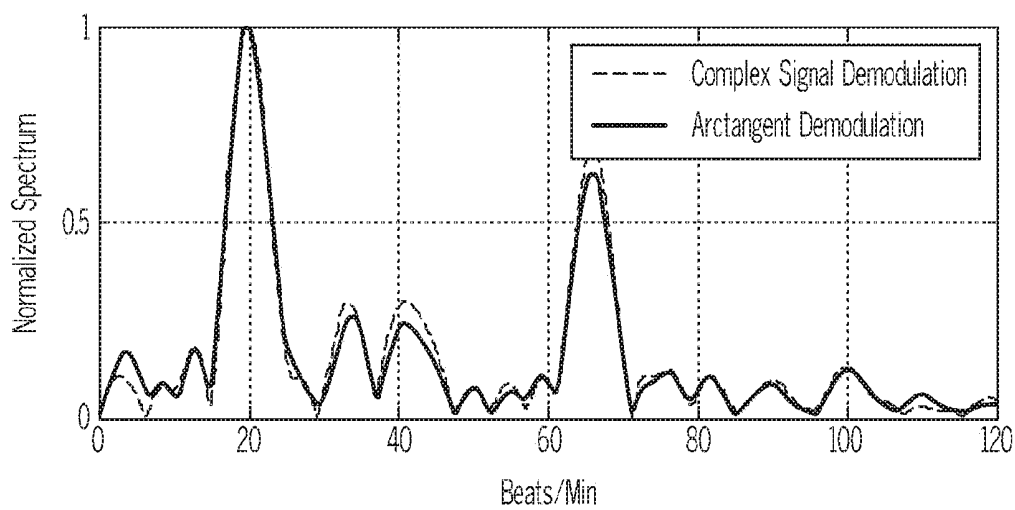

FIG. 12B

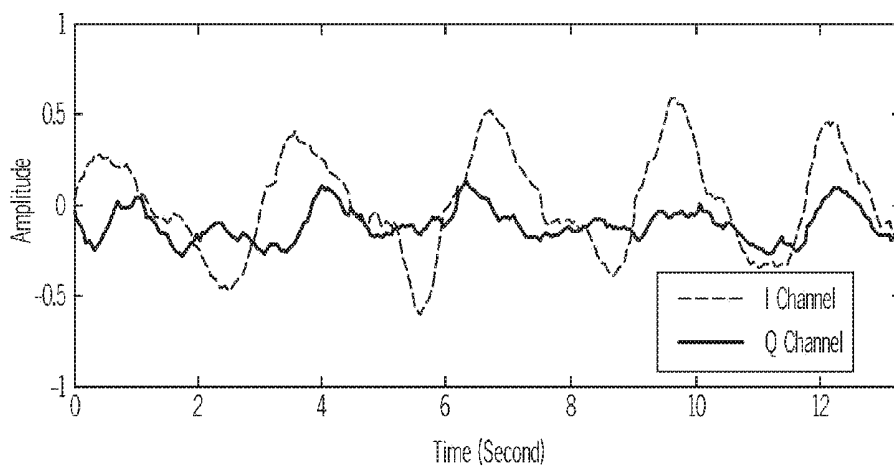

FIG. 13A

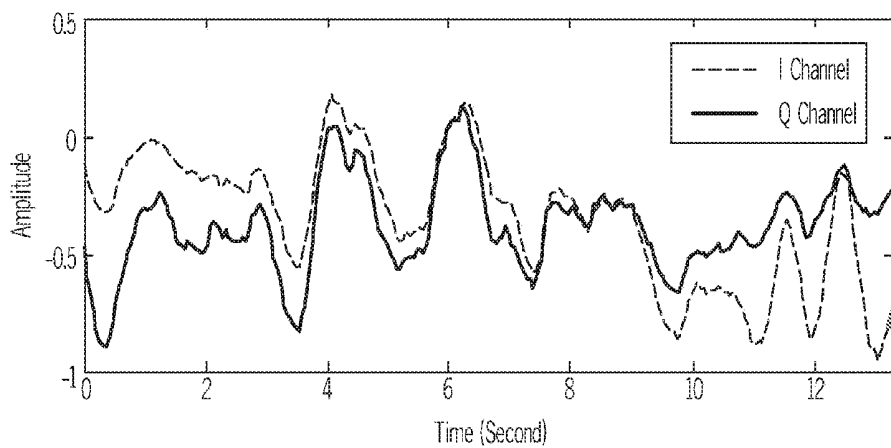

FIG. 13B

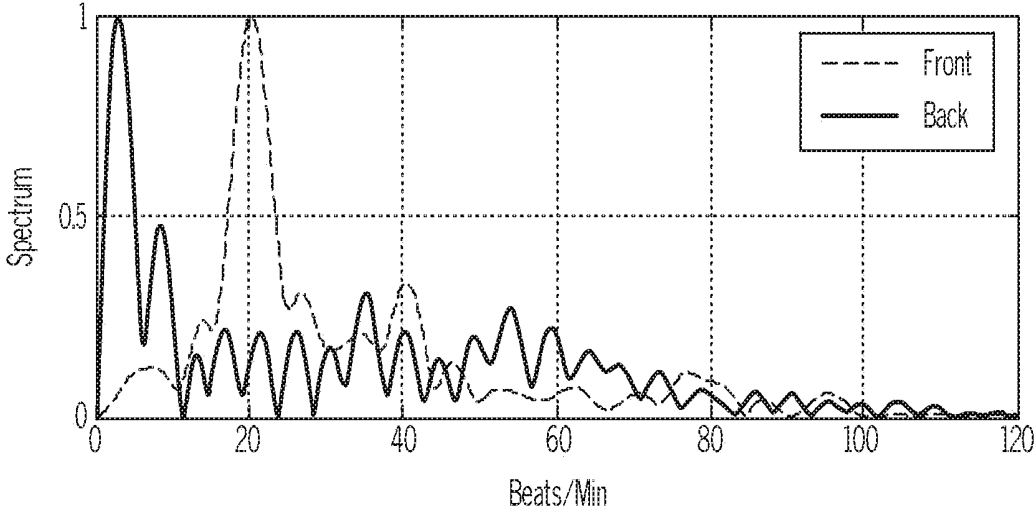

FIG. 14A

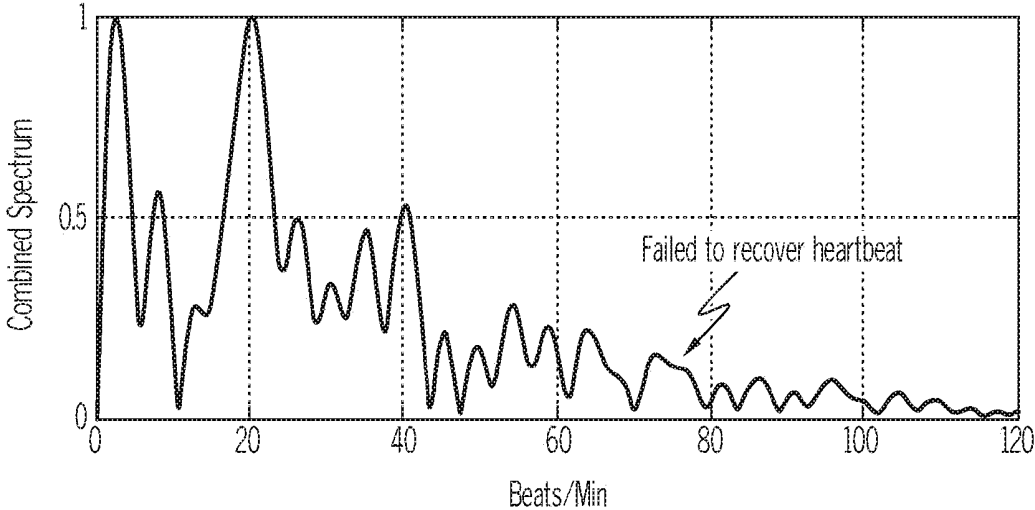

FIG. 14B

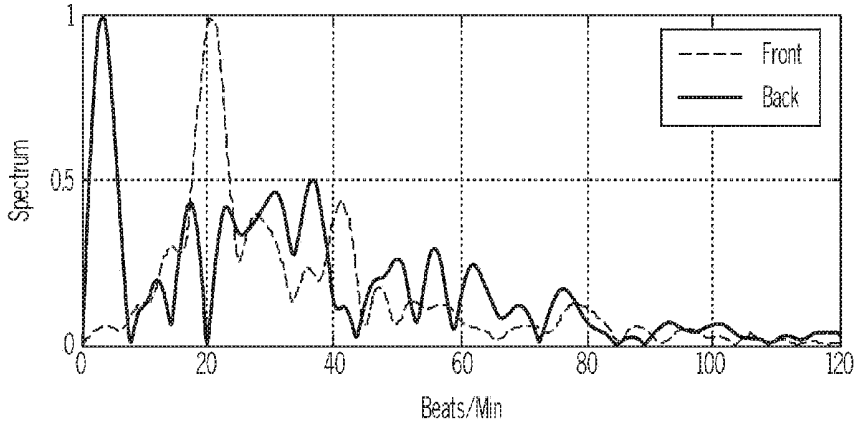

FIG. 15A

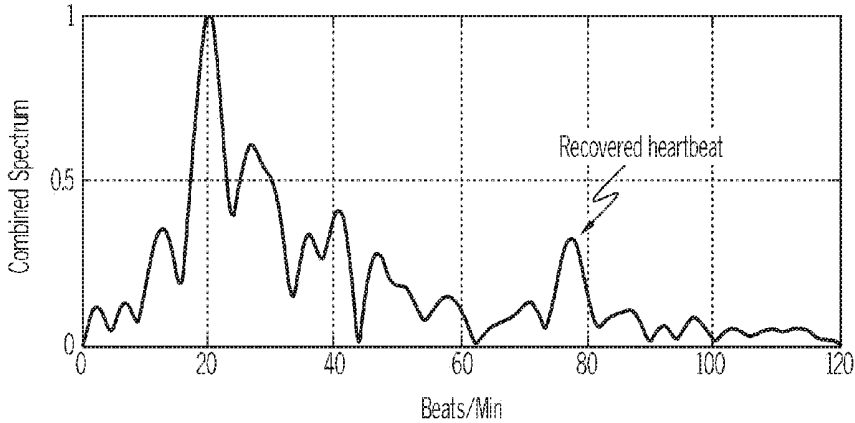

FIG. 15B

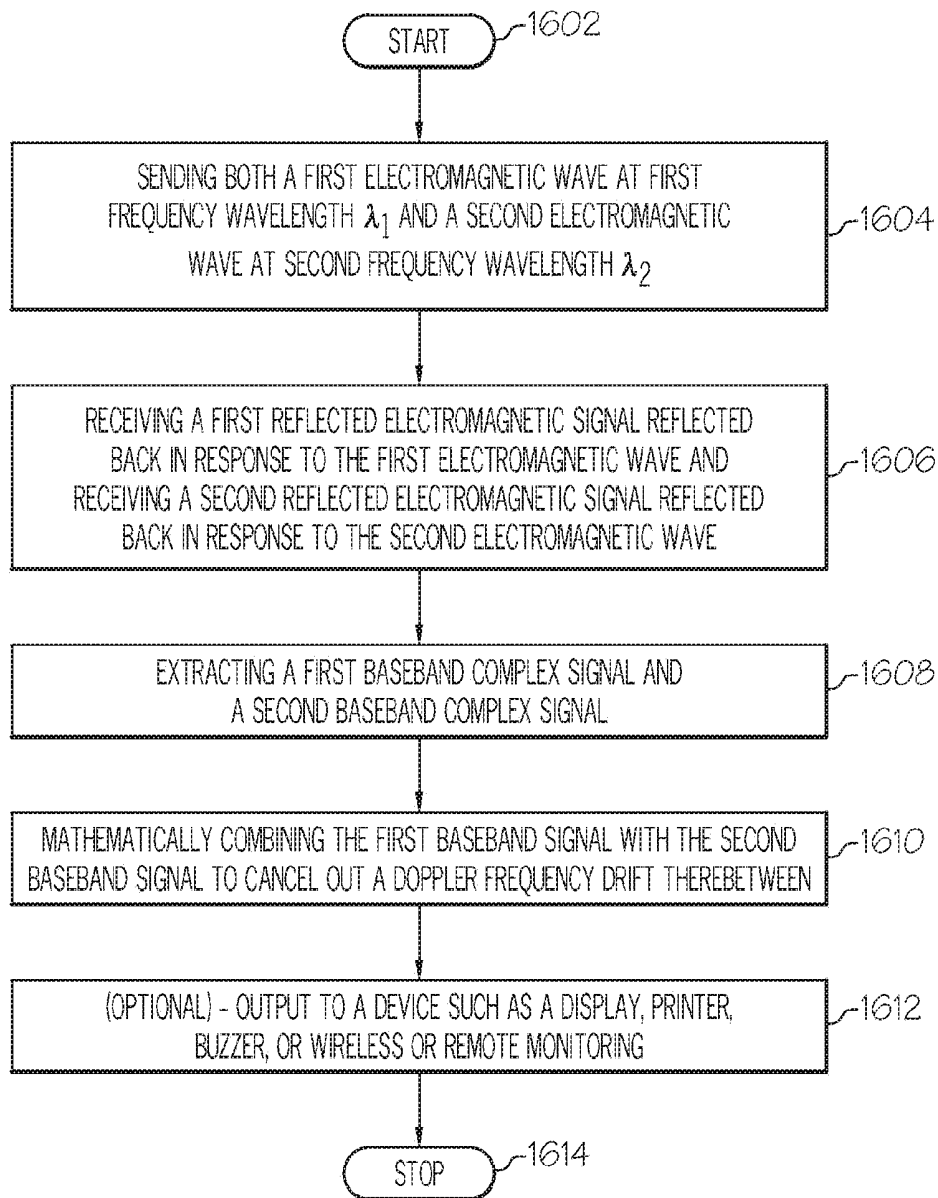

FIG. 16

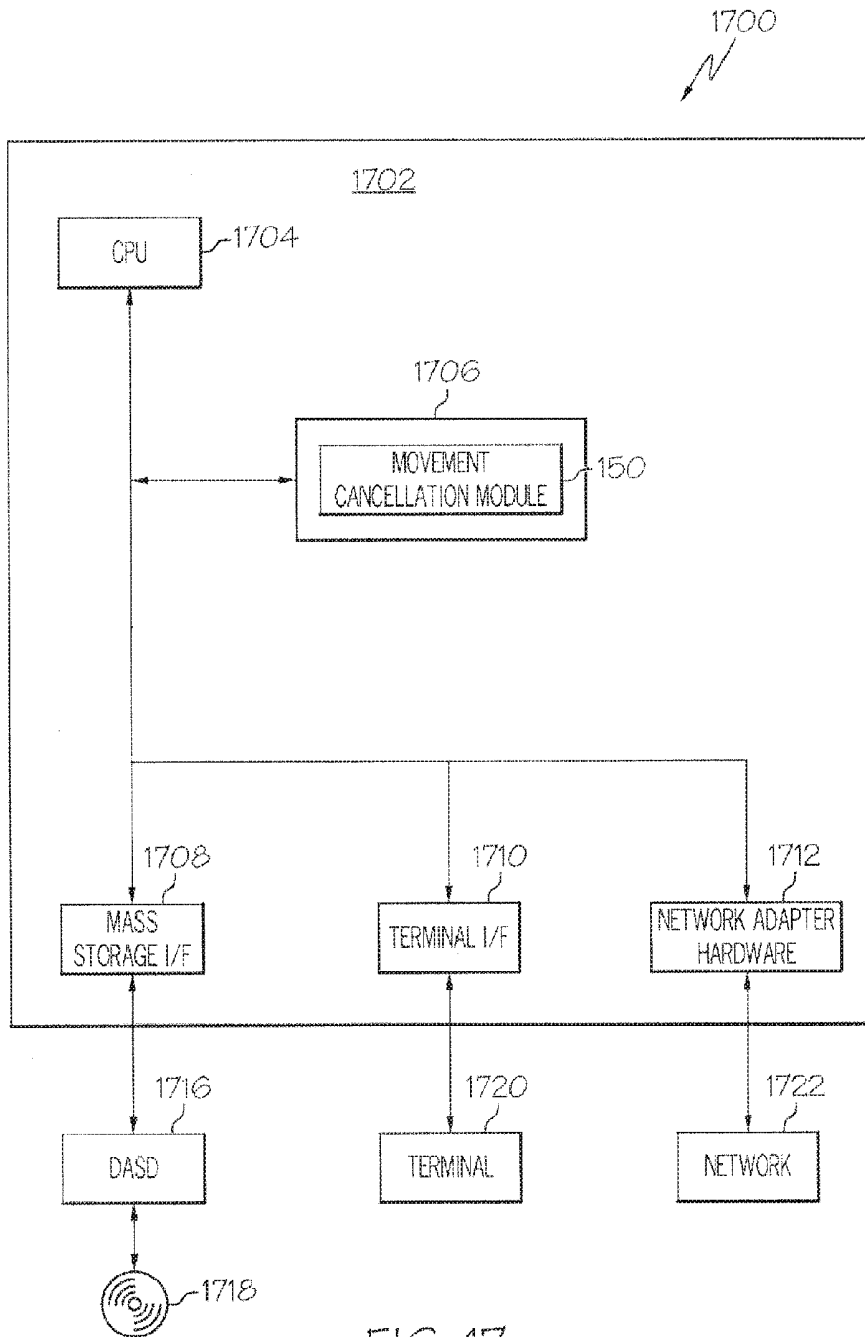

FIG. 17

**RANDOM BODY MOVEMENT  
CANCELLATION FOR NON-CONTACT  
VITAL SIGN DETECTION**

CROSS REFERENCE TO RELATED  
APPLICATIONS

[0001] The present application is a continuation of U.S. application Ser. No. 12/668,700, filed Jan. 12, 2010, which is the U.S. national stage application of International Application No. PCT/US2008/069766, filed Jul. 11, 2008, which claims the benefit of U.S. Provisional Application Ser. No. 60/949,285, filed Jul. 12, 2007, each of which is hereby incorporated by reference herein in its entirety, including any figures, tables, nucleic acid sequences, amino acid sequences, or drawings.

FIELD OF THE INVENTION

[0002] The present invention relates generally to non-contact monitoring and more specifically a method and system to eliminate random body movements during non-contact vital sign monitoring.

BACKGROUND OF THE INVENTION

[0003] In practical applications of non-contact vital sign detection, the noise caused by irregular body movement presents severe interference for accurate detection of vital signs such as respiration and heartbeat signal. Since random body movement is comparable or even stronger than the weak vital sign signal, to some extent it is the main factor limiting the applications of non-contact vital sign sensors.

[0004] To reduce body movement, prior art techniques require that the subject or patient being monitored remain stationary and motionless. In many applications such as healthcare, sports, law enforcement, security, it is difficult if not impossible to have the subject being monitored to remain stationary.

[0005] Accordingly, what is needed is a method and a system to overcome the aforementioned problems and to recover severely distorted signals during non-contact vital sign detection even when the subject is not stationary.

SUMMARY OF THE INVENTION

[0006] The present invention provides a method and a system to cancel out noise due to random body movement during non-contact vital sign monitoring. The present invention recovers severely distorted signal to obtain accurate measurement result, solving the main problem prohibiting the wide daily application of non-contact vital sensors.

[0007] Described is a random body movement cancellation in quadrature Doppler radar non-contact vital sign detection using complex signal demodulation and the arctangent demodulation. Applications using the present invention include sleep apnea monitor, lie detector, and baby monitor to eliminate the false alarm caused by random body movement. It has been shown that if the DC offset of the baseband signal is accurately calibrated, both demodulation techniques can be used for random body movement cancellation. While the complex signal demodulation is less likely to be affected by a DC offset, the arctangent demodulation has the advantage of eliminating harmonic and intermodulation interference at high carrier frequencies. In applications where the DC offset cannot be accurately calibrated, the complex signal demodulation is used. Ray-tracing model

is used to show the effects of constellation deformation and optimum/null detection ambiguity caused by the phase offset due to finite antenna directivity. Experiments have been performed using 4-7 GHz radar.

[0008] In one embodiment the present invention method for cancelling random body by sending at least two electromagnetic signals comprising a first electromagnetic signal with a first frequency to a first side of a body from a first electromagnetic wave transceiver and a second electromagnetic signal with a second frequency to a second side of a body from a second electromagnetic wave transceiver. A first reflected electromagnetic signal reflected back in response to the first electromagnetic wave on the first transceiver is received and a first baseband complex signal is extracted. Likewise a second reflected electromagnetic signal reflected back in response to the second electromagnetic wave on the second transceiver is received and a second baseband complex signal is extracted. The first baseband complex signal is mathematically combined with the second baseband complex signal to cancel out a Doppler frequency drift therebetween to yield a periodic Doppler phase effect. Vital signs such as respiration rate and heart rate are extracted from the signal representing the periodic Doppler phase effect.

[0009] The foregoing and other features and advantages of the present invention will be apparent from the following more particular description of the preferred embodiments of the invention, as illustrated in the accompanying drawings.

BRIEF DESCRIPTION OF THE DRAWINGS

[0010] The subject matter, which is regarded as the invention, is particularly pointed out and distinctly claimed in the claims at the conclusion of the specification. The foregoing and other features, and advantages of the invention will be apparent from the following detailed description taken in conjunction with the accompanying drawings in which:

[0011] FIG. 1 is a system diagram of the multi-antenna and multi-wavelength technique, according to the present invention.

[0012] FIGS. 2A-2B show block diagrams illustrating: (FIG. 2A) a complex signal demodulation; and (FIG. 2B) an arctangent demodulation, according to the present invention.

[0013] FIGS. 3A-3B show graphs illustrating: (FIG. 3A) ray-tracing model and the angular information (FIG. 3B) ray-tracing model of signals reflected from point A and B on the body using a 5.8 GHz radar, according to the present invention.

[0014] FIGS. 4A-4D show a ray-tracing model illustrating: (FIG. 4A) the phase offset on the surface of human body radiated by a 5.8 GHz radar; (FIG. 4B) a 7 by 7 elements antenna array's radiation intensity on the human body; (FIG. 4C) approximation of the normalized amplitude of body movement caused by respiration; and (FIG. 4D) approximation of the normalized amplitude of body movement caused by heartbeat, according to the present invention.

[0015] FIGS. 5A-5D show a graph of demodulation for a 5.8 GHz radar illustrating: (FIG. 5A) a signal detected at heart center (Case I) and at body center (Case II); (FIG. 5B) an actual received signal (Case III); (FIG. 5C) an angular information  $\psi(t)$  of the received signal; and (FIG. 5D) baseband spectra obtained by the complex signal demodulation and the arctangent demodulation (the DC component is not shown in the baseband spectrum).

**[0016]** FIGS. 6A-6C show a graph of demodulation for a 24 GHz radar illustrating: (FIG. 6A) a signal detected at heart center (Case I) and at body center (Case II); (FIG. 6B) an actual received signal (Case III), with the recovered angular information shown in inset; (FIG. 6C) a baseband spectra obtained by the complex signal demodulation and the arctangent demodulation (DC component not shown in the spectra), according to the present invention.

**[0017]** FIGS. 7A-7B show a graph of a baseband spectrum detected by the I and the Q channels with a carrier frequency of 24 GHz illustrating: (FIG. 7A) a spectrum of a single-beam signal projected to the heart center; and (FIG. 7B) a spectrum of the actually received signal, according to the present invention.

**[0018]** FIGS. 8A-8B show a graph of baseband spectra obtained when random body movement is present illustrating: (FIG. 8A) the random body movement is shown in the Z, X, and Y directions, which are defined in FIGS. 3A-3B; and (FIG. 8B) a baseband spectra by arctangent demodulation (AD) and complex signal demodulation (CSD), according to the present invention.

**[0019]** FIGS. 9A-9B show a graph of illustrating: (FIG. 9A) angular information and baseband spectrum; and (FIG. 9B) angular information recovered by random body movement cancellation (RBMC) using the two demodulation techniques; accurate DC information is used in demodulation but not shown in the spectrum, according to the present invention.

**[0020]** FIGS. 10A-10B show a graph illustrating: (FIG. 10A) angular information and baseband spectrum; and (FIG. 10B) angular information recovered from the random body movement cancellation (RBMC) technique; the random body movements are modeled in three dimensions, and the DC offset in each transceiver is 30% of the maximum signal amplitude, according to the present invention.

**[0021]** FIG. 11 is a block diagram of the 4-7 GHz radar transceiver as shown in FIG. 1, according to the present invention.

**[0022]** FIGS. 12A-12B show a graph of DC offset estimation illustrating: (FIG. 12A) a trajectory of detected baseband signal with no DC information and with estimated DC offset level added; and (FIG. 12B) a spectra obtained by the two demodulation techniques. Signal with estimated DC offset added was used for arctangent demodulation.

**[0023]** FIGS. 13A-13B show a graph of signals detected from: (FIG. 13A) the front of a human body; and (FIG. 13B) the back of the human body, according to the present invention.

**[0024]** FIGS. 14A-14B show a graph of random body movement cancellation using arctangent demodulation illustrating: (FIG. 14A) a spectra measured from the front and the back of the human body; (FIG. 14B) a spectrum from combining the two transceiver outputs, the heartbeat information cannot be recovered due to inaccurate DC offset information, according to the present invention.

**[0025]** FIGS. 15A-15B show a graph of random body movement cancellation using complex signal demodulation illustrating: (FIG. 15A) a spectra measured from the front and the back of the human body; and (FIG. 15B) an output spectrum by the random body movement cancellation technique, the heartbeat information is recovered, according to the present invention.

**[0026]** FIG. 16 is a flow diagram of the overall random body movement cancellation, according to the present invention.

**[0027]** FIG. 17 is a generalized block diagram of a computer system useful for implementing the noise cancellation algorithm according to the present invention.

## DESCRIPTION OF THE PREFERRED EMBODIMENTS

**[0028]** It should be understood that these embodiments are only examples of the many advantageous uses of the innovative teachings herein. In general, statements made in the specification of the present application do not necessarily limit any of the various claimed inventions. Moreover, some statements may apply to some inventive features but not to others. In general, unless otherwise indicated, singular elements may be in the plural and vice versa with no loss of generality. The term "body" or "patient" or "person" or "subject" is used interchangeably herein to refer to any living organism that has vital signs such as heart beat and respiration including humans and animals.

### I. INTRODUCTION

**[0029]** The present invention has many advantages over the prior art system. One advantage is the present invention cancels out noise due to random body movement during non-contact vital sign monitoring. The present invention recovers severely distorted signal to obtain accurate measurement result, solving the main problem prohibiting the wide daily application of non-contact vital sensors.

**[0030]** Further, the present invention does not require subjects to remain stationary and motionless. It makes the existing applications of non-contact sensing more robust. This has broad application in such diverse areas as health-care, sports, law enforcement, security, social networking where the subjects may move around during detection. Improved applications include monitoring systems, bio-medical sensors, lie detectors, military personal radar carried by soldiers for behind-the-wall sensing, and security systems. All of the above systems and applications are non-contact and can be made portable.

**[0031]** In one embodiment the present invention uses a complex signal demodulation used for random body movement cancellation. In another embodiment of the present invention uses an important demodulation method of non-contact vital sign detection, i.e. the arctangent demodulation, for random body movement cancellation. It is shown that if the baseband DC offset information is known, both of the two demodulation techniques can be used for random body movement cancellation. When the DC offset cannot be accurately calibrated out, the complex signal demodulation is more favorable for random body movement cancellation. The ray-tracing model used illustrates the effects of constellation deformation and optimum/null detection ambiguity caused by the phase offset due to finite antenna directivity.

**[0032]** Two modulations embodiments are described in order to mathematically combine the first baseband complex signal with the second baseband complex signal to cancel out a Doppler frequency drift in order to yield a periodic Doppler phase effect. The two demodulation embodiments and their implementation for random body movement cancellation are described below in the section entitled II Complex-Signal Demodulation and Arctangent Demodula-

tion. The effect of phase offset is discussed in Section III. Simulations have been performed and the results are reported in Section IV. Experimental results are presented in Section V, and a conclusion is drawn in Section VI.

## II. COMPLEX-SIGNAL DEMODULATION AND ARCTANGENT DEMODULATION

**[0033]** The present invention utilizes a multi-antenna and multi-wavelength technique that combines signals detected from different body orientation to cancel out random body movements based on different Doppler frequency shifts detected. This technique can recover severely distorted signal to achieve robust non-contact measurement of heart-beat rate and respiration rate from a distance away. This invention includes the theory/method and both the hardware system and software algorithm to implement the method. When random body movement is present and it affects accurate detection, the measurement has to be performed simultaneously from both sides to cancel out the random frequency drift. This is described further in the publication by C. Li, and J. Lin, "Complex Signal Demodulation and Random Body Movement Cancellation Techniques for Non-contact Vital Sign Detection," IEEE MTT-S International Microwave Symposium Digest, June, 2008, which is hereby incorporate by reference in its entirety.

**[0034]** Turning now to FIG. 1, shown is a system diagram **100** or Doppler radar non-contact vital sign detection. The system **100** includes the multi-transceiver **102**, **112** and multi-wavelength technique **104** and **114** i.e.  $\lambda$  and  $\lambda'$ . The two transceivers, one in front of and the other behind the subject **160**, are transmitting and receiving signals with different wavelength to avoid interference to each other. It is important to note that although the transceivers are shown in front and back, other positions such as one side of the body and the other side of the body can be used.

**[0035]** In one embodiment, each transceiver **102** and **112** is identical. A signal generator **122** is fed into a splitter **124**. One output of the splitter is fed to a quadrature splitter **126** and the other output fed to the transmitter output through a circulator **120** producing wave  $\lambda$  **114**. The signal received which is reflected off the subject **160** through circulator **120** is fed to multipliers **128** and **130** followed by a quadrature splitter **126** to produce an output. The output quadrature Q and in-phase I component of each down sampled signal from each transceiver **102** and **112** are directed to a respective DAQ (digital acquisition module) **132**, **142**. Each DAQ **132** and **142** is fed to a movement cancellation algorithm **150**. In one embodiment the body movement cancellation algorithm **150** is implemented as part of a computer. More specifically the body movement cancellation algorithm **150** is implemented in software to process the signals detected from different transceivers. The resulting detected wave is outputted to a display **152** or other output device such as a printer, buzzer, or wireless to a remote monitoring station (not shown). This algorithm is described further in the sections below. It is important to note that the present invention can be implemented in a combination of hardware and software, such as dedicated hardware system and that the present invention is not limited to using a computer to implement this algorithm.

**[0036]** In the analysis of non-contact quadrature demodulation of vital sign, the single-beam model assumes an ideal antenna with infinite directivity focusing a beam at the location of the heart. When no random body movement is

present, the normalized detected baseband signal in one of the baseband I/Q channels can be represented and analyzed by spectral analysis:

$$B(t) = \cos\left(\frac{4\pi x_h(t)}{\lambda} + \frac{4\pi x_r(t)}{\lambda} + \phi\right) \quad (1)$$

$$= \sum_{k=-\infty}^{\infty} \sum_{l=-\infty}^{\infty} J_l\left(\frac{4\pi m_h}{\lambda}\right) J_k\left(\frac{4\pi m_r}{\lambda}\right) \cos(k\omega_r t + l\omega_h t + \phi)$$

where  $x_h(t) = m_h \sin \omega_h t$ ,  $x_r(t) = m_r \sin \omega_r t$  are the periodic body movements due to heartbeat and respiration,  $\lambda$  is the wavelength of the wireless signal,  $\phi$  is the total residual phase accumulated in the circuit and along the transmission path, and  $J_n$  is the Bessel function of the first kind.

**[0037]** For a quadrature transceiver, the baseband output in the I/Q channel can be represented as  $B(t)$  and the quadrature of  $B(t)$ . Meanwhile, the Bessel coefficient with a negative index number and a positive index number in equation (1) can be combined using the property:  $J_n(x) = J_{-n}(x)$  for even numbers of  $n$  and  $J_n(x) = -J_{-n}(x)$  for odd numbers of  $n$ . Therefore, the baseband I/Q output can be represented as:

$$I(t) = \cos\left(\frac{4\pi x_h(t)}{\lambda} + \frac{4\pi x_r(t)}{\lambda} + \phi\right) \quad (2.a)$$

$$= DC_I - 2[C_{10} \sin(\omega_r t) + C_{01} \sin(\omega_h t) + \dots] \cdot \sin \phi + 2[C_{20} \cos(2\omega_r t) + C_{02} \cos(2\omega_h t) + \dots] \cdot \cos \phi$$

$$Q(t) = \sin\left(\frac{4\pi x_h(t)}{\lambda} + \frac{4\pi x_r(t)}{\lambda} + \phi\right) \quad (2.b)$$

$$= DC_Q + 2[C_{10} \sin(\omega_r t) + C_{01} \sin(\omega_h t) + \dots] \cdot \cos \phi + 2[C_{20} \cos(2\omega_r t) + C_{02} \cos(2\omega_h t) + \dots] \cdot \sin \phi$$

where  $C_{ij} = J_i(4\pi m_r/\lambda) \cdot J_j(4\pi m_h/\lambda)$  determines the amplitude of every frequency component. The ellipses in equations (2.a) and (2.b) represent higher order odd and even harmonics.

**[0038]** From equations (2.a) and (2.b), the ratio of  $\cos \phi$  and  $\sin \phi$  determines the relative strength between the even order and the odd order harmonics. Therefore, the optimal/null detection point is determined by the residue phase  $\phi$ . For example, when  $\phi$  is close to  $90^\circ$ , the fundamental frequency of respiration and heartbeat signals dominates in the I channel while the second order harmonic of desired signals dominates in the Q channel, thus I is close to the optimal detection point and Q is close to the null detection point. According to the single-beam model, when either one of the two quadrature channels is close to an optimal detection point, the other one should be close to the null detection point.

### A. Complex Signal Demodulation

**[0039]** It is important to note that although the frequency of wavelengths  $\lambda$  and  $\lambda'$  are described as substantially similar, these frequencies can be selected to be very close to each other. The lack of a phase-lock loop coupled between transceivers **102** and **112** is the cause for this slight difference.

**[0040]** Two free running VCOs are used for the two transmitters so that  $\lambda_1$  and  $\lambda_2$  are close to each other but

always have a slight difference because the system does not incorporate any phase-locked-loop. This provides the following advantages: Firstly, the signal from one transceiver can be easily rejected by the other transceiver, because the slight difference in radio frequency results in a large difference in baseband signal for vital sign detection and can easily filter out signal from the other transceiver. Secondly, since  $\lambda_1$  and  $\lambda_2$  are set very close, it enables the movement cancellation method to cancel out Doppler frequency shift due to random body movement, as will be shown theoretically in the following. Finally, the free running VCO without phase-locked-loop significantly reduces the complexity and cost of this technique.

**[0041]** Referring now to FIGS. 2A-2B shown is a block diagram illustrating: (FIG. 2A) a complex signal demodulation; and (FIG. 2B) an arctangent demodulation, according to the present invention. The complex signal demodulation of FIG. 2A can eliminate the optimum/null detection point problem by combining the I and Q signals in baseband. As shown in Equation (2.a), the complex signal is software-reconstructed in real time as:

$$\begin{aligned} S(t) &= I(t) + j \cdot Q(t) \\ &= \exp\left\{j\left[\frac{4\pi x_h(t)}{\lambda} + \frac{4\pi x_r(t)}{\lambda} + \phi\right]\right\} \\ &= DC_{IQ} + 2j[C_{10}\sin(\omega_r t) + C_{01}\sin(\omega_h t) + \dots] \cdot e^{j\phi} + \\ &\quad 2[C_{20}\cos(2\omega_r t) + C_{02}\cos(2\omega_h t) + \dots] \cdot e^{j\phi} \end{aligned} \quad (3)$$

where  $e^{j\phi}$  has a constant envelope of one, and thus the effect of  $\phi$  on signal amplitude can be eliminated. Applying the complex Fourier transform to the signal  $S(t)$  for spectral analysis, the residual phase  $\phi$  will not affect the relative strength between the odd order and the even order frequency components. The desired signal components (odd order tones) will always be present in the spectrum.

**[0042]** Meanwhile, the DC components accumulated in the I and the Q channels only contribute to the DC term in the complex signal  $S(t)$ , thus does not affect obtaining the frequency of the desired signal component. In practice, the residual baseband DC components can be easily extracted as the average of signals in every time-domain sliding window and thus be safely removed. As a result, the complex signal demodulation greatly simplifies the demodulation procedure and is immune from DC offset when no random body movement is present. However, the complex signal demodulation is not able to completely eliminate the higher even order harmonics.

**[0043]** For random body movement cancellation, measurements need to be performed from both sides of the human body. In this way, the signal detected from the two transceivers can be expressed as:

$$S_f(t) = \exp\left\{j\left[\frac{4\pi x_{h1}(t)}{\lambda} + \frac{4\pi x_{r1}(t)}{\lambda} + \frac{4\pi y(t)}{\lambda} + \phi_1\right]\right\} \quad (4.a)$$

$$S_b(t) = \exp\left\{j\left[\frac{4\pi x_{h2}(t)}{\lambda} + \frac{4\pi x_{r2}(t)}{\lambda} - \frac{4\pi y(t)}{\lambda} + \phi_2\right]\right\} \quad (4.b)$$

where  $x_{h1}(t)$  and  $x_{r1}(t)$  are the heartbeat-induced and the respiration-induced physiological movements on the front

chest wall,  $x_{h2}(t)$  and  $x_{r2}(t)$  are the heartbeat-induced and the respiration-induced physiological movements on the back,  $\phi_1, \phi_2$  are the residual phase of the transceivers in front of the body and behind the body, and  $y(t)$  is the random body movement. Note that the pairs of physiological movements on both sides of the body, e.g.  $x_{h1}(t)$  and  $x_{h2}(t)$ , move in the same direction relative to their respective detecting radar. On the other hand, when the body is drifting toward one of the radars, it is moving away from the other one. Therefore, by multiplying  $S_f(t)$  and  $S_b(t)$ , the  $y(t)$  term in the baseband output  $S_b(t) = S_f(t) \cdot S_b(t)$  will be cancelled out, while the physiological movement terms are enhanced:

$$S_b(t) = \exp\left\{j\left[\frac{4\pi[x_{h1}(t) + x_{h2}(t)]}{\lambda} + \frac{4\pi[x_{r1}(t) + x_{r2}(t)]}{\lambda} + \phi_1 + \phi_2\right]\right\} \quad (5)$$

**[0044]** The above operation can also be interpreted as convolution and frequency shift in frequency domain, thus canceling the Doppler frequency drift and keeping only the periodic Doppler phase effects.

**[0045]** Although it is shown that the complex signal demodulation itself does not require the baseband DC offset information, the performance of random body movement cancellation is affected by the DC offset. Proper estimation or calibration of the DC offset is beneficial for successful cancellation of the noise due to random body movement.

## B. Arctangent Demodulation

**[0046]** Referring now to FIG. 2B shown is block diagram of arctangent demodulation, according to the present invention. Another way to eliminate the optimum/null detection point problem in the quadrature demodulation system is to use arctangent demodulation by calculating the total Doppler phase shift. Its block diagram is shown in FIG. 2B. This is described further in the publication by B. Park, O. Boric-Lubecke, and V. M. Lubecke, "Arctangent demodulation with DC offset compensation in quadrature Doppler radar receiver systems", IEEE Trans. Microwave Theory and Techniques, vol. 55, pp. 1073-1079, May 2007, which is hereby incorporated by reference in its entirety. Taking into account the phase discontinuity when the signal trajectory crosses the boundary of two adjacent quadrants, the arctangent demodulation calculates the total angular information  $\psi(t)$  as:

$$\psi(t) = \arctan\frac{Q(t)}{I(t)} + F = \frac{4\pi x_h(t)}{\lambda} + \frac{4\pi x_r(t)}{\lambda} + \phi \quad (6)$$

where  $F$  is a multiple of  $180^\circ$  for the purpose of eliminating the discontinuity when  $\psi(t)$  crosses the boundary of two adjacent quadrants in the constellation graph.

**[0047]** Because  $\psi(t)$  is a linear combination of the desired signal  $x_h(t)$  and  $x_r(t)$ , the information of the vital signs can be obtained with the nonlinear phase modulation effect eliminated. The advantage is the ability to eliminate the harmonic and intermodulation interference. However, previous demonstration of this embodiment accurate calibration of the DC offset is needed in order to properly reconstruct the angular information. This is described further in the publication by B. Park, O. Boric-Lubecke, and V. M. Lubecke, "Arctangent demodulation with DC offset com-

pensation in quadrature Doppler radar receiver systems”, IEEE Trans. Microwave Theory and Techniques, vol. 55, pp. 1073-1079, May 2007, which is hereby incorporate by reference in its entirety.

**[0048]** The difficulty of accurate DC offset calibration encountered in Doppler radar vital sign detection is that the DC offset is not only produced by the electronic circuit, but also by the unmodulated reflected signal, i.e. signal reflected from stationary objects and other parts of the human body rather than the moving chest wall. Therefore, the DC offset changes as the environment changes and needs to be calibrated when it is changed. Again, this is described further in the publication by B. Park, O. Boric-Lubecke, and V. M. Lubecke, “Arctangent demodulation with DC offset compensation in quadrature Doppler radar receiver systems”, IEEE Trans. Microwave Theory and Techniques, vol. 55, pp. 1073-1079, May 2007, which is hereby incorporate by reference in its entirety.

**[0049]** On the other hand, the presence of baseband DC offset results in a shifted trajectory in the constellation graph. Although the angular information  $\psi(t)$  will be changed significantly when the trajectory is shifted, the angular movement is still periodic. This implies that when analyzing the spectrum of  $\psi(t)$  in the presence of a DC offset, the desired frequency components still exist. The difference observed in the spectrum is a changed harmonic level. Therefore, if the DC offset can be properly estimated, it is still possible to extract the desired vital signs. As will be demonstrated in Section V, a trajectory-fitting procedure is adopted in this paper for DC offset estimation in baseband. Experiments will show that this procedure can be used for vital sign detection in the absence of random body movement.

**[0050]** When random body movement is present, the angular information recovered from the front ( $\psi_f$ ) and the back ( $\psi_b$ ) of the human body can be expressed as:

$$\psi_f(t) = \frac{4\pi x_{h1}(t)}{\lambda} + \frac{4\pi x_{r1}(t)}{\lambda} + \frac{4\pi y(t)}{\lambda} + \phi_1 \quad (7.a)$$

$$\psi_b(t) = \frac{4\pi x_{h2}(t)}{\lambda} + \frac{4\pi x_{r2}(t)}{\lambda} - \frac{4\pi y(t)}{\lambda} + \phi_2 \quad (7.b)$$

where  $x_{h1}(t)$ ,  $x_{r1}(t)$ ,  $x_{h2}(t)$ ,  $x_{r2}(t)$ ,  $\phi_1$ , and  $\phi_2$  are the same as defined in Section II-A. Instead of multiplying the two signals as in the case of using complex signal demodulation, the random body movement can be cancelled out by adding the angular information of equations (7.a) and (7.b) together to obtain  $\psi_{fb}(t) = \psi_f(t) + \psi_b(t)$ :

$$\psi_{fb}(t) = \frac{4\pi[x_{h1}(t) + x_{h2}(t)]}{\lambda} + \frac{4\pi[x_{r1}(t) + x_{r2}(t)]}{\lambda} + \phi_1 + \phi_2 \quad (8)$$

### III. EFFECTS OF PHASE OFFSET

**[0051]** Since a real antenna with a certain radiation pattern does not have infinite directivity, signals are reflected and captured from different parts of the body. When signals on different paths with different intensity and residual phases are received by the radar, they are simply summed together by the receiving antenna, either canceling out or enhancing the desired signal components. Therefore, a ray-tracing

model is developed to compensate for the shortage of the single-beam model. This is described further in the publication by C. Li, Y. Xiao, and J. Lin, “Design Guidelines for Radio Frequency Non-contact Vital Sign Detection,” Proceedings of the 29th Annual International Conference of the IEEE EMBS, pp. 1651-1654, Lyon, France, Aug. 23-26, 2007, which is hereby incorporate by reference in its entirety.

**[0052]** FIGS. 3A-3B show graphs illustrating: (FIG. 3A) ray-tracing model and the angular information (FIG. 3B) ray-tracing model of signals reflected from point A and B on the body using a 5.8 GHz radar, according to the present invention. The antenna is facing the body in the  $-Z$  direction of the X-Y-Z coordinate. As shown in FIG. 3 (FIG. 3A), the actual received signal should be represented from a ray-tracing point of view as:

$$I(t) = \int \int_s E(x, y) \cdot \cos \left[ \Delta\phi + \frac{4\pi}{\lambda} \left\{ \rho(x, y)^2 + [d_0 + m_h(x, y)\sin(\omega_h t) + m_r(x, y)\sin(\omega_r t)]^2 \right\}^{1/2} \right] \times ds \quad (9.a)$$

$$Q(t) = \int \int_s E(x, y) \cdot \sin \left[ \Delta\phi + \frac{4\pi}{\lambda} \left\{ \rho(x, y)^2 + [d_0 + m_h(x, y)\sin(\omega_h t) + m_r(x, y)\sin(\omega_r t)]^2 \right\}^{1/2} \right] \times ds \quad (9.b)$$

**[0053]** Assume the antenna is placed 1 m away in front of the heart center, and the locations of the heart center A and the body center B on the front chest wall are separated by 11 cm. The difference in the transmission path for signals from the antenna to the two points is  $\Delta x = \sqrt{1^2 + 0.11^2} - 1 = 0.006$  m, which is replicated in the receiving path and would produce a phase difference of 83.5 degree for a 5.8 GHz radar. Meanwhile, the radiation intensity of the antenna on the body surface is different from point to point, depending on the antenna radiation pattern. This implies that the received baseband signals from the two points will have different locations and movement patterns in the constellation graph, as shown in FIG. 3 (FIG. 3B). Therefore, the real case for vital sign detection using complex signal demodulation and arctangent demodulation is complicated by the phase offset. Numerical simulations are needed and will be presented in the following section.

### IV. SIMULATION

**[0054]** Simulations have been performed based on the ray-tracing model. The two demodulation techniques were applied to vital sign detection in the presence/absence of random body movement.

**[0055]** A. Ray-Tracing Model

**[0056]** FIGS. 4A-4D. is a ray-tracing model illustrating: (FIG. 4A) the phase offset on the surface of human body radiated by a 5.8 GHz radar; (FIG. 4B) a 7 by 7 elements antenna array’s radiation intensity on the human body; (FIG. 4C) approximation of the normalized amplitude of body movement caused by respiration; and (FIG. 4D) approximation of the normalized amplitude of body movement caused by heartbeat, according to the present invention. The body model for a subject of 1.8 m height is shown in FIG. 4A-4D. Assuming the antenna is 1 m in front of the heart center, the phase offset in different paths compared with the

beam propagating to the center of the heart is shown in FIG. 4A for a 5.8 GHz radar sensor. Dramatic change in phase offset is observed. Shown in FIG. 4B is the radiation intensity on the human body produced by an ideal 7 by 7 antenna array comprised of omnidirectional antennas spaced by  $\lambda/2$ . FIGS. 4C and 4D are the approximation of the normalized amplitude of body movements caused by respiration and heartbeat, respectively. It can be inferred that when a carrier frequency of 24 GHz is used for the higher sensitivity at shorter wavelengths, the phase change will be more significant.

**[0057]** B. Demodulation without Random Body Movement

**[0058]** To demonstrate the properties of the two demodulation techniques, numerical simulations were first performed without random body movement present. Two examples are presented, i.e. a 5.8 GHz quadrature radar, and a 24 GHz quadrature radar. Three types of signals were recorded and analyzed.

**[0059]** Case I: a single-beam signal projected to the heart center, i.e. point A in FIG. 3A. This is the case analyzed by the single-beam model.

**[0060]** Case II: a single-beam signal projected to the body center, i.e. point B in FIG. 3A. In this case, respiration signal was picked up while heartbeat signal is almost absent.

**[0061]** Case III: the actual signal transmitted and received by the radar.

**[0062]** It should be noted that only Case III can be realized in the laboratory. Case I and II analyze signals carried by a hypothetical single beam radiated by an antenna with a very high directivity radiation pattern.

#### Example I

##### 5.8 GHz Quadrature Radar

**[0063]** Simulation results are shown in FIGS. 5A-5D for detection from the back of the human body. More specifically FIGS. 5A-5B is a graph of demodulation for a 5.8 GHz radar illustrating: (FIG. 5A) a signal detected at heart center (Case I) and at body center (Case II); (FIG. 5B) an actual received signal (Case III); (FIG. 5C) an angular information  $\psi(t)$  of the received signal; and (FIG. 5D) baseband spectra obtained by the complex signal demodulation and the arctangent demodulation (the DC component is not shown in the baseband spectrum). The residual phase produced in the electronic circuit was assumed to be  $0^\circ$ , which means the Q channel was at the optimum detection point while the I channel was at the null detection point according to the single-beam model.

**[0064]** FIGS. 5A-5B show the signal trajectories in the constellation graph. As predicted in Section II, signals reflected from different parts of the human body are affected by two variations: the phase offset and the radiation intensity. The former variation embodies itself as different angles of the trajectory shown in FIG. 5A, while the latter is demonstrated as different radii of the trajectory. As a result, when the receiver receives the vital sign signals, which is the superposition of all the signals reflected from different parts of the body, the total received signal trajectory is deformed from an ideal circle, as shown in FIG. 5B. It should be noted that the constellation deformation is not caused by noise, which was not included in simulation.

**[0065]** Although the foregoing discussions and simulation results appear undesirable, the recovered angular informa-

tion based on equation (6) is nonetheless periodic and not seriously disturbed by the phase offset problem, as shown in FIG. 5C. The spectrum of the complex signal and the recovered angular information were analyzed and plotted in FIG. 5D. Although the detection was made with one channel at the null detection point and the other at the optimum detection point, both of the two demodulation techniques can successfully identify the respiration and heartbeat components.

**[0066]** Therefore, the complex signal demodulation and the arctangent demodulation for 5.8 GHz radar system are demonstrated to be effective solutions to achieve reliable detection and eliminate the null detection point problem.

#### Example II

##### 24 GHz Quadrature Radar

**[0067]** In this example, the carrier frequency was 24 GHz and the residual phase produced in the electronic circuit was assumed to be  $450^\circ$ , which means the detection was performed at the middle between the null and the optimum detection points. The constellation plots are shown in FIGS. 6A-6C. More specifically, FIGS. 6A-6C are graphs of demodulation for a 24 GHz radar illustrating: (FIG. 6A) a signal detected at heart center (Case I) and at body center (Case II); (FIG. 6B) an actual received signal (Case III), with the recovered angular information shown in inset; (FIG. 6C) a baseband spectra obtained by the complex signal demodulation and the arctangent demodulation (DC component not shown in the spectra), according to the present invention. The complex signal demodulation causes harmonic ( $H_2$ ) and intermodulation (Int) interference. Due to fast variation of the phase offset on the surface of the human body, more severe trajectory deformation was observed. However, angular information recovered from equation (6) is still periodic, as shown in the inset of FIG. 6B. The baseband spectra from the two demodulation techniques are shown in FIG. 6C. Again, the respiration and the heartbeat components can be identified from the spectrum by using both of the techniques.

**[0068]** Furthermore, the result in FIG. 6C verifies that the arctangent demodulation can eliminate the harmonics and intermodulation terms caused by the nonlinear phase modulation effect, making the spectrum cleaner than that obtained by complex signal demodulation.

**[0069]** Another phenomenon to be noted is the optimum/null detection ambiguity. FIGS. 7A-7B is a graph of a baseband spectrum detected by the I and the Q channels with a carrier frequency of 24 GHz illustrating: (FIG. 7A) a spectrum of a single-beam signal projected to the heart center; and (FIG. 7B) a spectrum of the actually received signal, according to the present invention. Shown in FIG. 7A is the baseband spectrum of the I and the Q channels in Case I, i.e. the spectrum of the single beam signal projected to the center of the heart. The peaks of the respiration and the heartbeat components in I channel have the same amplitudes as those in Q channel, which is in accordance with equations (2.a) and (2.b) predicted by the single-beam model since the detection was performed at the mid-point between the null and the optimum detection points. However, the baseband spectrum of the actual received signal, as shown in FIG. 7B, shows that the I and the Q channels have significant differences in the heartbeat signal strength. While the I channel preserves the heartbeat signal, the Q channel shows strong

harmonic and intermodulation components. This is because of the enhancement and cancellation among signals with different phase offsets. And it demonstrates the necessity of effectively combining the two channels even when the detection is not carried out at the null detection point.

**[0070]** C. Random Body Movement Cancellation

**[0071]** The random body movement cancellation technique was also simulated using the ray-tracing model with a carrier frequency of 5.8 GHz. The random roaming of the body was fully modeled in three dimensions (X, Y, and Z) which are defined in FIGS. 3A-3B. Typically the subject under test has larger random body movements in two dimensions than the third dimension, e.g. the horizontal movements in the X and Z directions are more obvious than the vertical movement in the Y direction for a seated person. Therefore, the time-variant velocity of random body movement was modeled as uniform distribution between 0 and a maximum value of 4 mm/s in the X and the Z directions. And the amplitude of random body movement in the Y direction was modeled as 0.1 of that in the other two directions.

**[0072]** Turning now to FIGS. 8A-8B is a graph of baseband spectra obtained when random body movement is present illustrating: (FIG. 8A) the random body movement is shown in the Z, X, and Y directions, which are defined in FIGS. 3A-3B; and (FIG. 8B) a baseband spectra by arctangent demodulation (AD) and complex signal demodulation (CSD), according to the present invention. The movement components in each direction are shown in FIG. 8A, and the baseband spectra detected from the front and the back using the two demodulation techniques are shown in FIG. 8B. When random body movement is present, the desired respiration and heartbeat signal components will be overwhelmed by the noise generated by random body movement.

**[0073]** FIGS. 9A-9B show a graph illustrating: (FIG. 9A) angular information and baseband spectrum; and (FIG. 9B) angular information recovered by random body movement cancellation (RBMC) using the two demodulation techniques; accurate DC information is used in demodulation but not shown in the spectrum, according to the present invention. If the system can successfully preserve the DC offset information up to the baseband output, the recovered baseband angular information and the spectra obtained by random body movement cancellation were simulated and shown in FIGS. 9A-9B. The respiration and heartbeat components were successfully recovered by both demodulation techniques, which showed similar performance in recovering the desired signal components. It should be noted that although the random body movement can exist in the direction perpendicular to the radar direction, this technique still works reliably because only the movement in the radar direction is critical for the detection.

**[0074]** If the DC offset cannot be perfectly preserved up to the baseband output, however, the performance of random body movement cancellation based on both of the demodulation techniques deteriorates.

**[0075]** FIGS. 10A-10B show a graph illustrating: (FIG. 10A) angular information and baseband spectrum; and angular information recovered from the random body movement cancellation (RBMC) technique; the random body movements are modeled in three dimensions, and the DC offset in each transceiver is 30% of the maximum signal amplitude, according to the present invention. More specifically, shown in FIGS. 10A-10B is an example when DC offset was present at the baseband output of the two transceivers but not accurately preserved. For each transceiver, the baseband DC

offset levels were modeled to be the same in the I/Q channels and were 30% of the maximum signal amplitude. In the simulation, the above DC offset level was subtracted from the ideal I and Q channel signals. Then, both demodulation techniques were applied to cancel out the random body movement. It is shown that the complex signal demodulation can still identify the respiration and heartbeat components, but the arctangent demodulation is unable to recover the heartbeat signal. The reason for this disadvantage of using arctangent demodulation in random body movement cancellation is, as shown in equation (8), the cancellation is based on the linear combination of the calculated phase, which is strongly affected by the location of the constellation origin.

## V. EXPERIMENT

**[0076]** Experiments have been performed in the laboratory to verify the theory and compare the performance of the two demodulation techniques for random body movement cancellation. For consumer applications of this technique, it is desirable to have portable radars that can detect vital signs from several meters away, radiate a power of lower than 0 dBm, and have all the hardware integrated together at an affordable price. Therefore, 4-7 GHz portable radar was designed for this purpose. The radar integrates the quadrature transceiver, the two-stage baseband amplifier, and the power management circuit on a single printed circuit board (Rogers RO4350B substrate) with a size of 6.8x7.5 cm<sup>2</sup>. FIG. 11 is a block diagram of the 4-7 GHz radar transceiver as shown in FIG. 1, according to the present invention. The specifications and manufacturers of the radio frequency components are listed in Table I. For research purpose, four voltage controlled oscillators (VCO) were implemented for a wide tuning range to obtain different optimal carrier frequencies under different environments. This is further described in the publication by Li, and J. Lin, "Optimal Carrier Frequency of Non-contact Vital Sign Detectors," Proceedings of IEEE Radio and Wireless Symposium, pp. 281-284, Long Beach, Jan. 9-11, 2007, which is hereby incorporated by reference in its entirety. When a specific application is known, only one VCO is needed and the SP4T switch can be eliminated to further reduce the cost.

TABLE I

BUILDING BLOCKS AND SPECIFICATIONS USED IN 4-7 GHz RADAR		
Block	Manufacturer	Specifications
VCO1	Hittite	4.45-5.0 GHz, -105 dBc/Hz @100 kHz phase noise, 4 dBm output power
VCO2	Hittite	5.0-5.5 GHz, -103 dBc/Hz @100 kHz phase noise, 2 dBm output power
VCO3	Hittite	5.5-6.1 GHz, -102 dBc/Hz @100 kHz phase noise, 2 dBm output power
VCO4	Hittite	6.1-6.72 GHz, -101 dBc/Hz @100 kHz phase noise, 4.5 dBm output power
Switch	Hittite	DC-8 GHz, 40 dB isolation @6 GHz, 1.8 dB insertion loss @6 GHz, SP4T
Gain Block	RFMD	DC-8 GHz, 15.5 dB maximum gain, 14.5 dBm P1dB @6 GHz
Mixer	Hittite	4-8.5 GHz, 50 dB LO to RF isolation, 40 dB image rejection
LNA	Hittite	3.5-7.0 GHz, 16 dB gain, 2.5 dB NF

**[0077]** Since the vital sign has a frequency less than several Hertz, large coupling capacitors C1 and C2 of 10  $\mu$ F were used to isolate the DC voltages of the mixer output and baseband amplifier input. Because the 10  $\mu$ F coupling

capacitors block the DC signal in addition to isolating DC voltages of two different circuits, no DC information was recorded during the measurement. The coupling capacitor ( $C1, C2=10\ \mu\text{F}$ ) and the baseband amplifier input resistor ( $R1, R2=160\ \text{ks}$ ) were chosen such that for a heartbeat signal with a frequency around 1 Hz, the voltage drop on the capacitor is no more than  $\frac{1}{10}$  of the signal amplitude. This leads to a time constant of approximately 1.6 seconds, which means that in the real-time signal processing software, a 2 second initiation time is needed.

**[0078]** For random body movement cancellation, measurements were performed by two identical radars. In this embodiment patch antenna arrays with orthogonal polarization were installed in the two transceivers to eliminate the interference between the two units. An example of these radars is further described in the publication by C. Li, and J. Lin, "Complex Signal Demodulation and Random Body Movement Cancellation Techniques for Non-contact Vital Sign Detection," *IEEE MTT-S International Microwave Symposium Digest*, June, 2008, which is hereby incorporated by reference in its entirety. It was observed in the experiment that the antenna gain should be higher than 4 dB for the radar to have a good signal-to-noise ratio from up to 2 m away. The antenna was designed to have a maximum directivity gain of 9 dB at broadside, so that the vital signs of the subject in front of the antenna will be picked up. Free-running VCOs were used for the two transmitters so that the actual carrier wavelengths were close to each other but always had a slight difference in the absence of a phase-locked-loop. As a result, the signal from one transceiver was further rejected by the other transceiver in the baseband because the small difference in the carrier frequency results in a large difference in baseband frequency compared to the vital sign frequencies. The phase noise reduction due to range correlation makes the free-running VCO adequate for vital sign detection. This is further described in the publication by A. D. Droitcour, O. Boric-Lubecke, V. M. Lubecke, J. Lin, and G. T. A. Kovac, "Range correlation and I/Q performance benefits in single-chip silicon Doppler radars for noncontact cardiopulmonary monitoring," *IEEE Trans. Microwave Theory and Techniques*, vol. 52, pp. 838-848, March 2004, which is hereby incorporated by reference in its entirety along with the publication by M. C. Budge, Jr. and M. P. Burt, "Range correlation effects on phase and amplitude noise," *Proc. IEEE Southeastcon*, Charlotte, N.C., 1993, pp 5, which is hereby incorporated by reference in its entirety.

**[0079]** To reduce the hardware cost and the requirement of signal processing speed, the amplified baseband signals were sampled by a 12-bit multifunction data acquisition module (NI USB-6008) with a low sampling rate of 20 Hertz, which is fast enough for the vital sign signal of typically less than 2.5 Hertz. The sampled data were fed into a laptop for real-time signal processing by LabVIEW. The sampling rate and resolution make it possible to implement the baseband signal processing in a low cost DSP microchip such as the TI C2000 family digital signal controllers for various applications in the future.

**[0080]** To focus on the properties of demodulation and random body movement cancellation techniques, no baseband filtering was implemented in either hardware or software. All the results presented are based on the original baseband signal.

#### **[0081]** A. DC Offset Estimation in Baseband

**[0082]** Because of the coupling capacitor in the radar between the receiver output and the baseband amplifier input and the variability of DC offset within the experimental environment, it is relatively difficult to accurately calibrate out the DC offset of the whole system. Instead, the DC offset was estimated by fitting the signal trajectory into a proper segment of circle in the constellation graph.

**[0083]** Turning now to FIGS. 12A-12B show a graph of DC offset estimation illustrating: (FIG. 12A) a trajectory of detected baseband signal with no DC information and with estimated DC offset level added; and (FIG. 12B) a spectra obtained by the two demodulation techniques. Signal with estimated DC offset added was used for arctangent demodulation. For example, FIG. 12A shows the constellation graph of the baseband signal detected from the back of the human body when no random body movement was present. Because of the absence of DC information, the original signal trajectory was located at the center of the constellation graph. After adding an estimated DC offset level of 0.8 V for both I and Q channels in the baseband, the trajectory was fitted into a circle. FIG. 12B shows the baseband spectra obtained by the complex signal demodulation and the arctangent demodulation. As shown in both theory and experiment in, the DC offset does not affect complex signal demodulation when random body movement is absent. This is described further in the publication by C. Li, and J. Lin, "Complex Signal Demodulation and Random Body Movement Cancellation Techniques for Non-contact Vital Sign Detection," *IEEE MTT-S International Microwave Symposium Digest*, June, 2008, which is hereby incorporated by reference in its entirety. Therefore, the spectrum obtained by complex signal demodulation can be used as a reference to evaluate the reliability of arctangent demodulation using the estimated DC offset information. The spectra of FIG. 12B match well with each other, showing that the baseband DC offset estimation method is accurate enough for arctangent demodulation when no random body movement is present. Based on this DC offset estimation method, estimated DC offsets were added to original detected data and used for random body movement cancellation. However, it should be noted that in the presence of the random body movement, the DC information produced by the reflection from the bulk of the body always changes. Therefore, it is impossible to dynamically obtain the precise DC offset information of the overall system: no matter whether the DC offset is calibrated out using the method proposed in the publication by B. Park, O. Boric-Lubecke, and V. M. Lubecke, "Arctangent demodulation with DC offset compensation in quadrature Doppler radar receiver systems", *IEEE Trans. Microwave Theory and Techniques*, vol. 55, pp. 1073-1079, May 2007, which is hereby incorporated by reference in its entirety, or estimated by the signal trajectory fitting method of this paper, there will always be DC information error when the body position changes. And it is of great interest to compare in real experiments that how robust the two demodulation techniques are in the presence of the inevitable DC offset error.

#### **[0084]** B. Random Body Movement Cancellation

**[0085]** During the experiment, the subject under test was gently changing position in a chair, so that the noise of random body movement was emphasized. FIGS. 13A-13B show graphs of signals detected from: (FIG. 13A) the front of a human body; and (FIG. 13B) the back of the human body, according to the present invention. Further, FIGS.

**13A-13B** show the time domain signal detected from the front and the back of the human body when random body movement was present. Since the physiological movement caused by respiration and heartbeat has larger amplitude on the front chest wall than on the back, the signal detected from the back is more severely affected by the random body drift. Note that the detected signal amplitude shown in FIGS. **13A-13B** do not reflect the real physiological movement amplitude, since other factors such as distance and baseband amplifier gain also affect the signal level. For example, in the experiment, the baseband amplifier gain of the radar detecting from the back is 3 dB higher than the other one detecting from the front. The two demodulation techniques were used to cancel out random body movement to recover the desired signal.

**[0086]** The estimation based on signal trajectory fitting was used here for arctangent demodulation. FIGS. **14A-14B** show graphs of random body movement cancellation using arctangent demodulation illustrating: (FIG. **14A**) a spectra measured from the front and the back of the human body; (FIG. **14B**) a spectrum from combining the two transceiver outputs, the heartbeat information cannot be recovered due to inaccurate DC offset information, according to the present invention.

**[0087]** The baseband spectra detected from the front and the back of the human body are shown in FIG. **14A**. The angular information from the two transceivers was combined as described in Section II-B, and the resulting baseband spectrum is shown in FIG. **14B**. Due to the inaccuracy of DC offset estimation, the combined spectrum failed to recover the desired heartbeat signal component.

**[0088]** On the other hand, the same signals have been processed by the complex signal demodulation. FIGS. **15A-15B** show graphs of random body movement cancellation using complex signal demodulation illustrating: (FIG. **15A**) a spectra measured from the front and the back of the human body; and (FIG. **15B**) an output spectrum by the random body movement cancellation technique, the heartbeat information is recovered, according to the present invention. This is further described in the publication by C. Li, and J. Lin, "Complex Signal Demodulation and Random Body Movement Cancellation Techniques for Non-contact Vital Sign Detection," IEEE MTT-S International Microwave Symposium Digest, June, 2008, which is hereby incorporated by reference in its entirety.

**[0089]** FIG. **15A** shows the baseband spectra of the complex signal detected from the front and the back of the human body. Since the physiological movement at the back is weaker than that at the front chest wall, the noise completely overwhelmed the physiological signals from the back and only overwhelmed the heartbeat signal from the front. When the technique described in Section II-A was applied to combine the signals detected from the front and the back of the human body, the heartbeat signal was successfully recovered as shown in FIG. **15B**.

**[0090]** The above comparative study verifies the simulation in Section IV-C that the complex signal demodulation is more favorable in random body movement cancellation when the DC offset at baseband output cannot be accurately determined.

## VI. CONCLUSION AND NON-LIMITING EXAMPLES

**[0091]** Simulations and experiments have been performed to demonstrate the complex signal demodulation and the arctangent demodulation for random body movement cancellation in Doppler radar vital sign detection. The complex signal demodulation is easier to implement in that it does not need an intermediate signal processing stage to recover the angular information, and it is robust when DC offset is present. The latter property also makes it more favorable for random body movement cancellation. On the other hand, the arctangent demodulation has the advantage of eliminating the harmonic and intermodulation interference at high frequencies using high gain antennas. The effects of constellation deformation and optimum/null detection ambiguity caused by the phase offset due to finite antenna directivity are also discussed.

**[0092]** The present invention can be realized in hardware, software, or a combination of hardware and software. A system according to a preferred embodiment of the present invention can be realized in a centralized fashion in one computer system or in a distributed fashion where different elements are spread across several interconnected computer systems. Any kind of computer system—or other apparatus adapted for carrying out the methods described herein—is suited. A typical combination of hardware and software could be a general purpose computer system with a computer program that, when being loaded and executed, controls the computer system such that it carries out the methods described herein.

**[0093]** In general, the routines executed to implement the embodiments of the present invention, whether implemented as part of an operating system or a specific application, component, program, module, object or sequence of instructions may be referred to herein as a "program." The computer program typically is comprised of a multitude of instructions that will be translated by the native computer into a machine-readable format and hence executable instructions. Also, programs are comprised of variables and data structures that either reside locally to the program or are found in memory or on storage devices. In addition, various programs described herein may be identified based upon the application for which they are implemented in a specific embodiment of the invention. However, it should be appreciated that any particular program nomenclature that follows is used merely for convenience, and thus the invention should not be limited to use solely in any specific application identified and/or implied by such nomenclature.

**[0094]** FIG. **16** is a flow diagram of the overall random body movement cancellation, according to the present invention. The process begins in step **1602** and immediately proceeds to step **1604** with sending on at least two electromagnetic signals comprising a first electromagnetic signal with a first frequency to a first side of a body from a first electromagnetic wave transceiver and a second electromagnetic signal with a second frequency to a second side of a body from a second electromagnetic wave transceiver. Next in step **1606** these signals are received. In step **1608**, a first baseband signal and a second baseband signal are extracted out of the first electromagnetic signal and the second electromagnetic signal respectively. In step **1610** a demodulation is carried out by mathematically combining the first baseband complex signal with the second baseband complex signal to cancel out a Doppler frequency drift therebetween.

to yield a periodic Doppler phase effect. An optional step 1612 is performed for output the results to a device such as a display, printer, buzzer, storage or wireless device and the process ends in step 1614.

[0095] FIG. 17 is a generalized block diagram 1700 of a computer system useful for implementing the noise cancellation algorithm according to the present invention. The mass storage interface 1708 is used to connect mass storage devices, such as data storage device 1716, to the information processing system 1700. One specific type of data storage device is a computer readable medium such as DASD drive 1716, which may be used to store data to and read data from a CD 1718. The main memory 1706 comprises the movement cancellation module 150, which has been discussed above in greater detail. Although illustrated as concurrently resident in the main memory 1706, it is clear that respective component(s) of the main memory 1706 are not required to be completely resident in the main memory 1706 at all times or even at the same time.

[0096] Although only one CPU 1704 is illustrated for computer 1702, computer systems with multiple CPUs can be used equally effectively. Embodiments of the present invention further incorporate interfaces that each includes separate, fully programmed microprocessors that are used to off-load processing from the CPU 1704. Terminal interface 1710 is used to directly connect one or more terminals 1720 to computer 1702 to provide a user interface to the computer 1702. These terminals 1720, which are able to be non-intelligent or fully programmable workstations, are used to allow system administrators and users to communicate with the information processing system 1700. The terminal 1720 is also able to consist of user interface and peripheral devices that are connected to computer 1702 and controlled by terminal interface hardware included in the terminal I/F 1710 that includes video adapters and interfaces for keyboards, pointing devices, and the like.

[0097] An operating system (not shown) included in the main memory is a suitable multitasking operating system such as the Linux, UNIX, Windows, operating system. Embodiments of the present invention are able to use any other suitable operating system. Some embodiments of the present invention utilize architectures, such as an object oriented framework mechanism, that allows instructions of the components of operating system (not shown) to be executed on any processor located within the information processing system 1700. The network adapter hardware 1712 is used to provide an interface to the network 1722. Embodiments of the present invention are able to be adapted to work with any data communications connections including present day analog and/or digital techniques or via a future networking mechanism.

[0098] Although the exemplary embodiments of the present invention are described in the context of a fully functional computer system, those skilled in the art will appreciate that embodiments are capable of being distributed as a program product via CD or DVD, e.g. CD 1718, CD ROM, or other form of recordable media, or via any type of electronic transmission mechanism.

[0099] Further, even though a specific embodiment of the invention has been disclosed, it will be understood by those having skill in the art that changes can be made to this specific embodiment without departing from the spirit and scope of the invention. The scope of the invention is not to be restricted, therefore, to the specific embodiment, and it is

intended that the appended claims cover any and all such applications, modifications, and embodiments within the scope of the present invention.

1. A method for cancelling body movement effect for non-contact vital sign detection, comprising:

sending a first electromagnetic signal with a first frequency to a first side of a body from a first transceiver and a second electromagnetic signal with a second frequency to a second side of the body from a second transceiver, where the first frequency of wavelength  $\lambda_1$  and the second frequency of wavelength  $\lambda_2$  are close to each other so that ( $\lambda_1 \approx \lambda_2 \approx \lambda$ );

receiving at least a first reflected electromagnetic signal reflected back in response to the first electromagnetic signal via the first transceiver and receiving at least a second reflected electromagnetic signal reflected back in response to the second electromagnetic signal via the second transceiver;

generating an angular information output by combining a first angular information signal extracted from the first reflected electromagnetic signal with a second angular information signal extracted from the second reflected electromagnetic signal to cancel out a Doppler frequency drift therebetween, where the first and second angular information signals are combined by arctangent demodulation as expressed by:

$$\psi_f(t) = \frac{4\pi x_{h1}(t)}{\lambda} + \frac{4\pi x_{r1}(t)}{\lambda} + \frac{4\pi y(t)}{\lambda} + \phi_1 \text{ and}$$

$$\psi_b(t) = \frac{4\pi x_{h2}(t)}{\lambda} + \frac{4\pi x_{r2}(t)}{\lambda} + \frac{4\pi y(t)}{\lambda} + \phi_2,$$

where  $x_{h1}(t)$  and  $x_{r1}(t)$  are heartbeat-induced and respiration-induced physiological movements on the first side of the body,  $x_{h2}(t)$  and  $x_{r2}(t)$  are heartbeat-induced and respiration-induced physiological movements on the second side of the body,  $\phi_1$ ,  $\phi_2$  are residual phases of the first transceiver and the second transceiver, and  $y(t)$  is a body movement, where the  $y(t)$  term in the angular information output  $\psi_b(t) = \psi_f(t) + \psi_b(t)$  is cancelled out by adding  $\psi_f(t)$  and  $\psi_b(t)$ , while terms of physiological movement  $x_{h1}(t)$ ,  $x_{h2}(t)$ ,  $x_{r1}(t)$  and  $x_{r2}(t)$  are enhanced as expressed by:

$$\psi_b(t) = \frac{4\pi[x_{h1}(t) + x_{h2}(t)]}{\lambda} + \frac{4\pi[x_{r1}(t) + x_{r2}(t)]}{\lambda} + \phi_1 + \phi_2;$$

and

displaying a vital sign of the body extracted from the angular information output.

2. The method of claim 1, further comprising extracting at least one of respiration rate and heart rate from the angular information output.

3. The method of claim 2, further comprising sending the at least one of the respiration rate and the heart rate to a display.

4. The method of claim 2, further comprising sending the at least one of the respiration rate and the heart rate to a wireless output device for display.

5. The method of claim 1, wherein a DC offset of in-phase (I) and quadrature (Q) baseband components of at least one of the first and second reflected electromagnetic signals is calibrated out.

6. The method of claim 1, wherein a DC offset associated with at least one of the first and second reflected electromagnetic signals is calibrated using a trajectory-fitting procedure.

7. The method of claim 1, wherein the first transceiver and the second transceiver are anyone of:

5.8 GHz quadrature radar transceivers; and

24 GHz quadrature radar transceivers.

8. The method of claim 1, wherein the first and second angular information signals are based upon corresponding in-phase (I) and quadrature (Q) baseband components of the first and second reflected electromagnetic signals.

9. The method of claim 1, wherein the first side is a front of the body and the second side is a back of the body.

10. A system for cancelling body movement effect for non-contact vital sign detection, comprising:

a first transceiver configured to send a first electromagnetic signal with a first frequency to a first side of a body and receive a first reflected electromagnetic signal reflected back in response to the first electromagnetic signal;

a second transceiver configured to send a second electromagnetic signal with a second frequency to a second side of the body, where the first frequency and the second frequency are different frequencies, and receive a second reflected electromagnetic signal reflected back in response to the second electromagnetic signal, where the first frequency of wavelength  $\lambda_1$  and the second frequency of wavelength  $\lambda_2$  are close to each other so that ( $\lambda_1 \approx \lambda_2 \approx \lambda$ );

a processing system configured to generate an angular information output by combining a first angular information signal extracted from the first reflected electromagnetic signal with a second angular information signal extracted from the second reflected electromagnetic signal to cancel out a Doppler frequency drift therebetween, where the first and second angular information signals are combined by arctangent demodulation as expressed by:

$$\psi_f(t) = \frac{4\pi x_{h1}(t)}{\lambda} + \frac{4\pi x_{r1}(t)}{\lambda} + \frac{4\pi y(t)}{\lambda} + \phi_1 \text{ and}$$

$$\psi_b(t) = \frac{4\pi x_{h2}(t)}{\lambda} + \frac{4\pi x_{r2}(t)}{\lambda} + \frac{4\pi y(t)}{\lambda} + \phi_2,$$

where  $x_{h1}(t)$  and  $x_{r1}(t)$  are heartbeat-induced and respiration-induced physiological movements on the first side of the body,  $x_{h2}(t)$  and  $x_{r2}(t)$  are heartbeat-induced and respiration-induced physiological movements on the second side of the body,  $\phi_1, \phi_2$  are residual phases of the first transceiver and the second transceiver, and  $y(t)$  is a body movement, where the  $y(t)$  term in the angular information output  $\psi_{fb}(t) = \psi_f(t) + \psi_b(t)$  is cancelled out by adding  $\psi_f(t)$  and  $\psi_b(t)$ , while terms of physiological movement  $x_{h1}(t), x_{h2}(t), x_{r1}(t)$  and  $x_{r2}(t)$  are enhanced as expressed by:

$$\psi_{fb}(t) = \frac{4\pi[x_{h1}(t) + x_{h2}(t)]}{\lambda} + \frac{4\pi[x_{r1}(t) + x_{r2}(t)]}{\lambda} + \phi_1 + \phi_2;$$

and display a vital sign of the body extracted from the angular information output.

11. The system of claim 10, wherein the processing system is further configured to extract at least one of respiration rate and heart rate from the angular information output.

12. The system of claim 11, further comprising a display that displays the at least one of the respiration rate and the heart rate.

13. The system of claim 11, wherein the at least one of the respiration rate and the heart rate is communicated to a wireless output device for display.

14. The system of claim 11, wherein the at least one of the respiration rate and the heart rate is communicated to a storage device for subsequent access.

15. The system of claim 11, wherein a DC offset of in-phase (I) and quadrature (Q) baseband components of at least one of the first and second reflected electromagnetic signals is calibrated out.

16. The system of claim 10, wherein a DC offset associated with at least one of the first and second reflected electromagnetic signals is calibrated using a trajectory-fitting procedure.

17. The system of claim 10, wherein the first transceiver and the second transceiver are anyone of:

5.8 GHz quadrature radar transceivers; and

24 GHz quadrature radar transceivers.

18. The system of claim 10, wherein the first and second angular information signals are based upon corresponding in-phase (I) and quadrature (Q) baseband components of the first and second reflected electromagnetic signals.

19. The system of claim 18, wherein the I and Q baseband components are sampled by a digital acquisition module for subsequent processing.

20. The system of claim 10, wherein the first side is a front of the body and the second side is a back of the body.

\* \* \* \* \*

专利名称(译)	用于非接触式生命体征检测的随机身体运动消除		
公开(公告)号	<a href="#">US20160374622A1</a>	公开(公告)日	2016-12-29
申请号	US15/259580	申请日	2016-09-08
[标]申请(专利权)人(译)	佛罗里达大学研究基金会有限公司		
申请(专利权)人(译)	佛罗里达州研究基金会, Inc.的.大学.		
当前申请(专利权)人(译)	佛罗里达州研究基金会, Inc.的.大学.		
[标]发明人	LIN JENSHAN LI CHANGZHI LLU YA CHI		
发明人	LIN, JENSHAN LI, CHANGZHI LLU, YA-CHI		
IPC分类号	A61B5/00 A61B5/05 A61B5/0205 G06F17/14 G06F19/00		
CPC分类号	A61B5/7214 G06F17/14 G06F19/3418 A61B5/7278 A61B5/0816 A61B5/742 A61B5/6823 A61B5/05 A61B5/024 A61B5/0205 A61B5/0507 G01S7/032 G01S7/354 G01S7/40 G01S13/34 G01S13/536 G01S13/87 G01S13/88 G16H40/67 G16H80/00		
优先权	12/668700 2010-01-12 US PCT/US2008/069766 2008-07-11 WO 60/949285 2007-07-12 US		
其他公开文献	US9924906		
外部链接	<a href="#">Espacenet</a> <a href="#">USPTO</a>		

摘要(译)

描述了用于抵消非接触式生命体征检测的身体运动效果的方法和系统。该方法开始于在第一电磁波收发器上将具有第一频率的第一电磁信号发送到诸如人或动物的身体的第一侧。同时使用第二电磁波收发器，第二电磁信号以第二频率发送到主体的第二侧，其中第一频率和第二频率是不同的频率。响应于第一收发器上的第一电磁波而反射回的第一反射电磁信号被接收，并且提取第一基带复合信号。同样地，接收响应于第二收发器上的第二电磁波而反射回的第二反射电磁信号，并提取第二基带复合信号。第一基带复合信号在数学上与第二基带复合信号组合以抵消其间的多普勒频率漂移，以产生周期性多普勒相位效应。

