



US 20190274621A1

(19) **United States**

(12) **Patent Application Publication**  
**KIM**

(10) **Pub. No.: US 2019/0274621 A1**

(43) **Pub. Date: Sep. 12, 2019**

(54) **BREATH ANALYSIS SYSTEM USING GAS IMAGE DETECTION METHOD**

**Publication Classification**

(71) Applicant: **AJOU UNIVERSITY**  
**INDUSTRY-ACADEMIC**  
**COOPERATION FOUNDATION,**  
Suwon-si, Gyeonggi-do (KR)

(51) **Int. Cl.**  
*A61B 5/00* (2006.01)  
*A61B 5/0205* (2006.01)  
*A61B 5/01* (2006.01)  
*A61B 5/0476* (2006.01)

(72) Inventor: **Hyun Jun KIM**, Seoul (KR)

(52) **U.S. Cl.**  
CPC ..... *A61B 5/4818* (2013.01); *A61B 5/02055*  
(2013.01); *A61B 5/0075* (2013.01); *A61B*  
*5/0816* (2013.01); *A61B 5/0476* (2013.01);  
*A61B 5/6801* (2013.01); *A61B 5/742*  
(2013.01); *A61B 5/01* (2013.01)

(73) Assignee: **AJOU UNIVERSITY**  
**INDUSTRY-ACADEMIC**  
**COOPERATION FOUNDATION,**  
Suwon-si, Gyeonggi-do (KR)

(57) **ABSTRACT**

Provided is a respiration analysis system using a gas image detection method, the respiration analysis system including: an exhalation capturing unit provided adjacent to a subject and capturing an image of exhalation exhaled from the mouth and nose of the subject; and a control unit electrically connected to the exhalation capturing unit, and calculating and storing, as data, a respiration cycle and respiration volume from the image captured through the exhalation capturing unit. Accordingly, provided is the respiration analysis system using the gas image detection method, in which not only respiration of the subject is measured in a non-contact manner, but also hypopnea is determined by quantifying volume of the exhalation exhaled by the subject, thereby inferring a disease caused by the hypopnea.

(21) Appl. No.: **16/345,230**

(22) PCT Filed: **Sep. 29, 2017**

(86) PCT No.: **PCT/KR2017/011018**

§ 371 (c)(1),

(2) Date: **Apr. 25, 2019**

(30) **Foreign Application Priority Data**

Oct. 28, 2016 (KR) ..... 10-2016-0141615

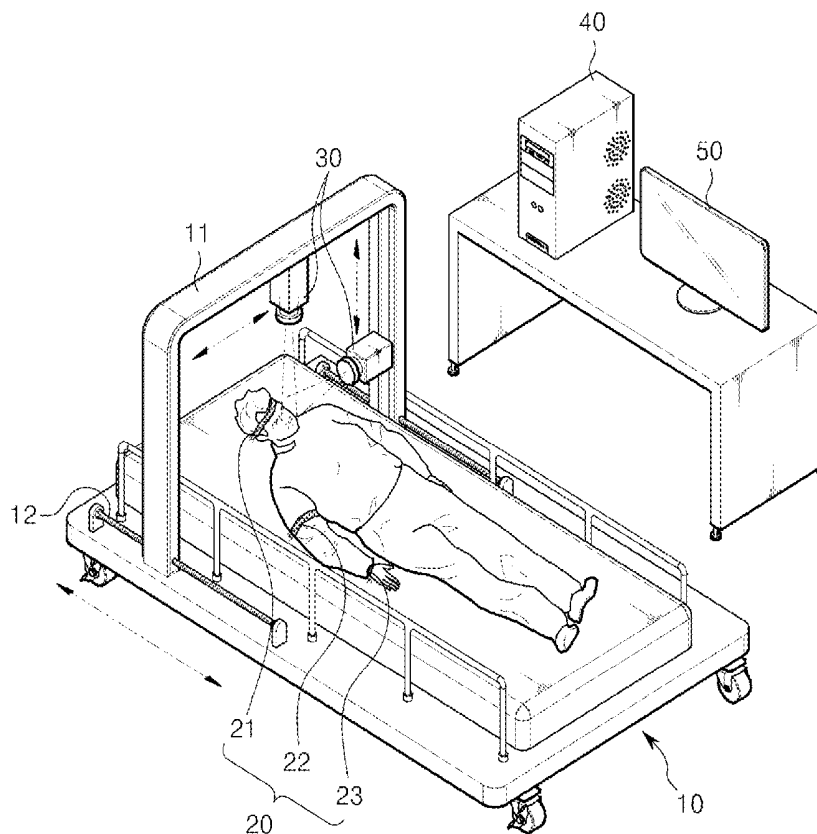
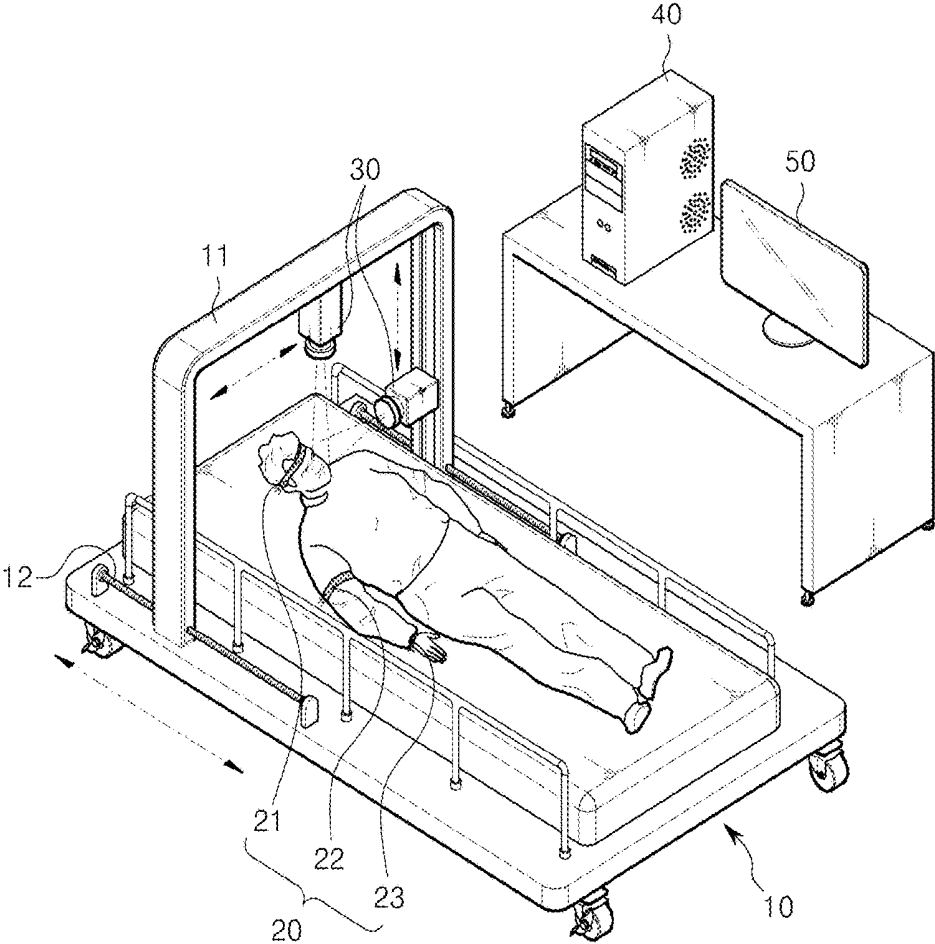
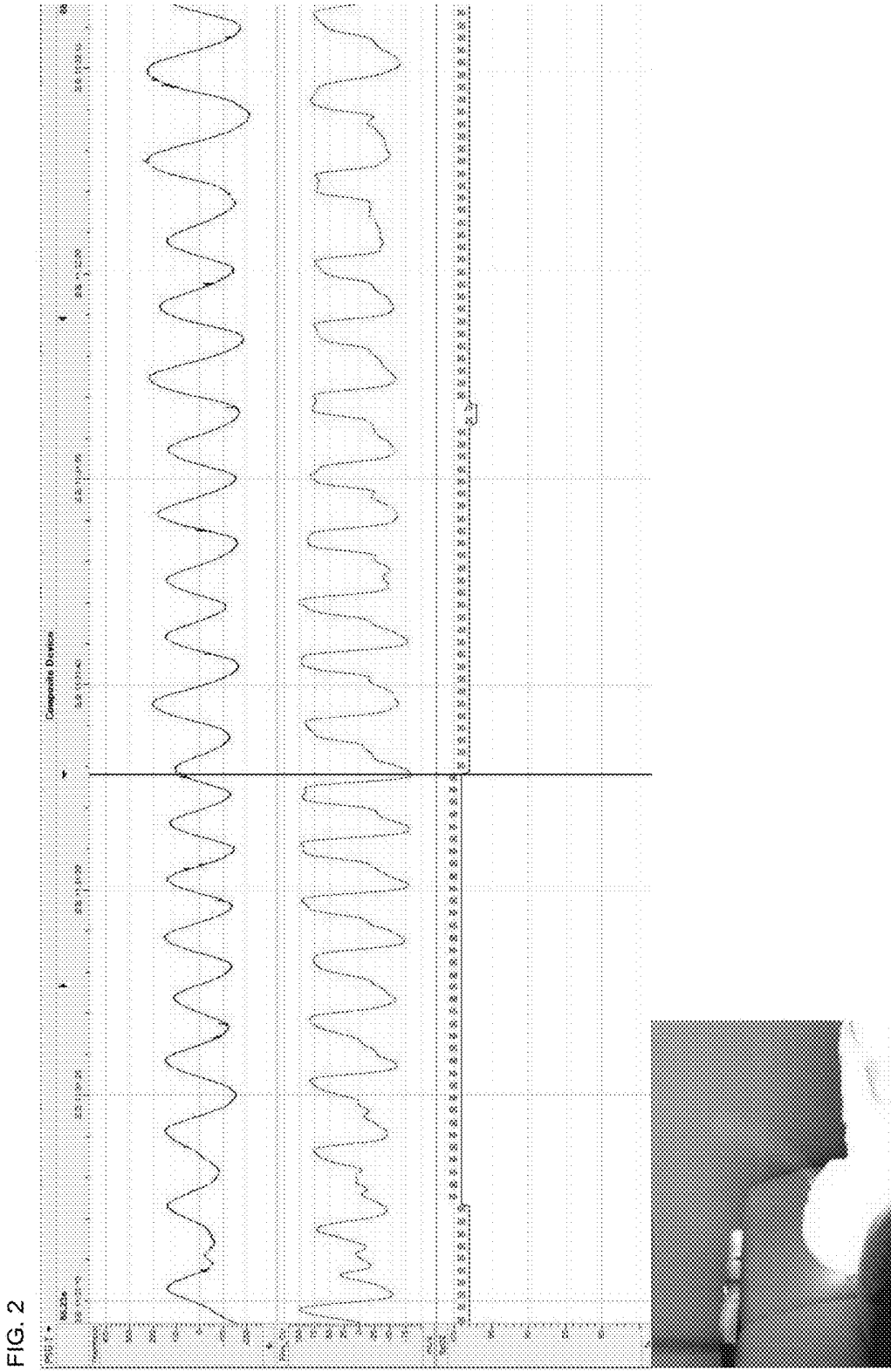
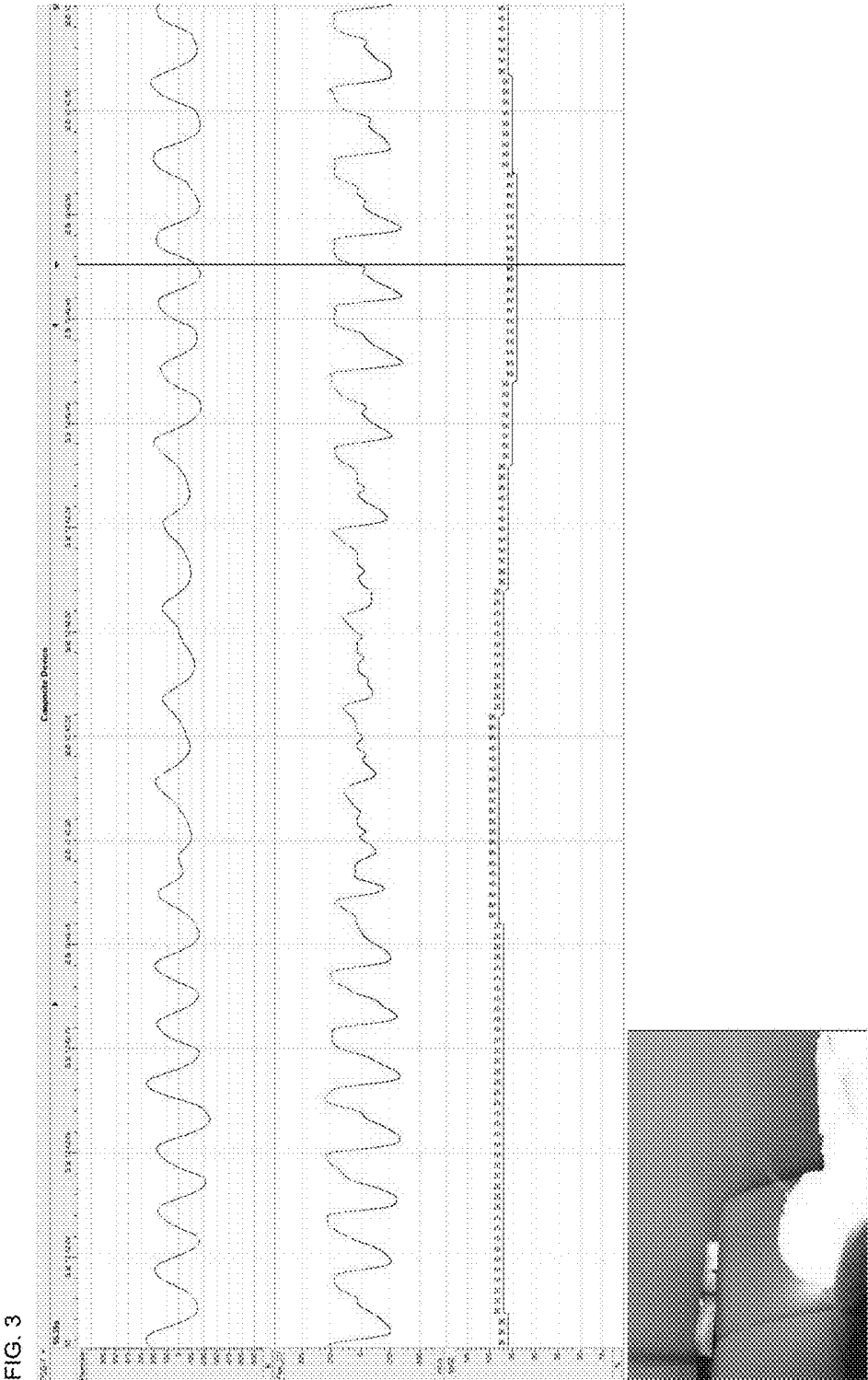
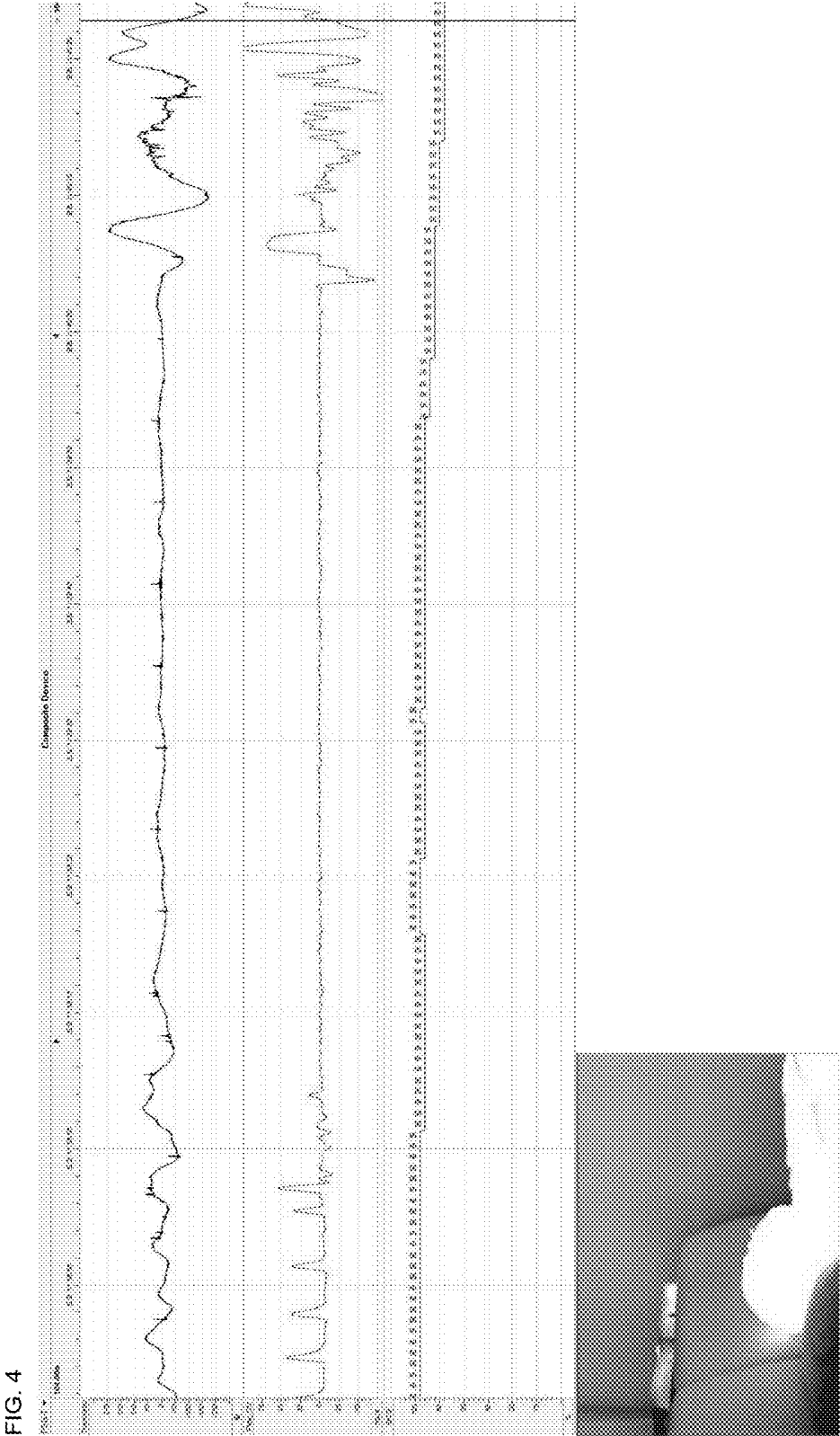

FIG. 1









## BREATH ANALYSIS SYSTEM USING GAS IMAGE DETECTION METHOD

### TECHNICAL FIELD

[0001] The present disclosure relates to a breath analysis system, and more particularly, to a breath analysis system using a gas image detection method, in which an image of exhalation of a subject is captured with a gas image detection infrared camera, respiration is quantified by using the captured image, and respiration of the subject, a respiration volume, and a respiration component are measured by using a quantitative difference of the respiration or a change in a temperature or the like.

### BACKGROUND ART

[0002] In general, there are many people who snore severely among adults over 30s, and such snoring is caused by extreme fatigue, obesity, stress, rhinitis, and sore throat.

[0003] Problems with the snoring are that the snoring may cause an apnea syndrome in which respiration is stopped for several seconds to several tens of seconds, thereby causing a serious fatigue phenomenon that causes a sudden drop in the quality of life to cause deterioration of efficiency of learning and work, and industrial accidents and traffic accidents, and in severe cases, dysfunction in cardiovascular activity and brain activity may be caused due to lack of oxygen supply in the body. In particular, a sleep apnea syndrome may be the cause of sudden death or unexpected death in a patient with heart disease, such as arrhythmia, myocardial infarction, or cardiac failure, or a patient with brain disease, such as cerebral infarction or cerebral apoplexy.

[0004] In order to prevent damage from the sleep apnea syndrome, a person with the sleep apnea syndrome may be cautious on his/her own, but unfortunately, it is difficult to self-realize the sleep apnea syndrome.

[0005] Thus, family members next to the person should tell the sleep apnea syndrome, but it is not simple for people to observe the person for a long time without sleeping, considering that a state in which respiration stops 20 times or more during 7 hours of sleep is the sleep apnea syndrome.

[0006] Recently, an apparatus for measuring and monitoring such apnea syndrome has been introduced, and there is an apparatus that measures the apnea syndrome by measuring and inputting, to a computer, a change in ventilation volume according to a change of respiration during sleep by mounting a respiration mask suitable to the size of the mouth and nose of a target.

[0007] Such a mask is unable to be unified to all people but should be specially manufactured according to shapes of the mouth and nose of the target. Also, an expensive conversion apparatus and software are required to convert the change in the respiration ventilation volume measured for a long time to an electric signal, input the electric signal to the computer, and analyze the electric signal, and the help from a specialist or a medical technician is required.

[0008] In addition to a conventional sleep apnea syndrome measuring apparatus being complicated to use and being expensive, since a special mask is worn on the mouth and nose during sleep and a connection line transmitting the respiration ventilation volume is lengthily connected to the computer, the measuring apparatus itself becomes stress, thereby affecting the sleep.

[0009] The conventional prior art may be identified in KR 10-2015-0033197 (published on Apr. 2, 2015).

### DESCRIPTION OF EMBODIMENTS

#### Technical Problem

[0010] The present disclosure is directed to providing a respiration analysis system using a gas image detection method, in which an image of exhalation of a subject is captured with a gas image detection infrared camera, and not only respiration of the subject may be measured in a non-contact manner by quantifying the respiration by using the captured image, but also a disease caused by hypopnea may be inferred by quantifying volume of exhalation exhaled by the subject to determine the hypopnea.

#### Solution to Problem

[0011] According to an aspect of the present disclosure, a respiration analysis system using a gas image detection method, the respiration analysis system includes: an exhalation capturing unit provided adjacent to a subject and capturing an image of exhalation exhaled from the mouth and nose of the subject; and a control unit electrically connected to the exhalation capturing unit, and calculating and storing, as data, a respiration cycle and respiration volume from the image captured through the exhalation capturing unit.

[0012] The exhalation capturing unit may capture a thermogram image in which a color or color density is changed according to changes in a temperature and humidity according to the exhalation exhaled from the mouth and nose of the subject, or capture a thermogram image in which a color or color density is changed according to a distribution of carbon dioxide in the exhalation exhaled from the mouth and nose of the subject, by using an infrared camera.

[0013] A plurality of the exhalation capturing units may be provided to capture an image of the exhalation on an orthogonal line based on the face of the subject.

[0014] The respiration analysis system may further include a bio-signal measuring unit electrically connected to the control unit to be mounted on the body of the subject and measuring a bio-signal of the subject, wherein the bio-signal measuring unit may include: a brainwave measuring sensor mounted on the head of the subject and measuring brainwaves of the subject; a temperature measuring sensor mounted on the body of the subject and measuring a temperature of the subject; and a pulse measuring sensor mounted on the body of the subject and measuring a pulse of the subject.

[0015] The respiration analysis system may further include a display unit electrically connected to the exhalation capturing unit and the control unit, display data according to a bio-signal stored in the control unit, and display the image of exhalation, which is to be captured or is captured.

[0016] The exhalation capturing unit, the control unit, and the display unit may be integrated in one body and configured as a wearable device mounted on the head or body of an observer observing the respiration of the subject or as a remote examination device using a computer and a network system.

#### Advantageous Effects of Disclosure

[0017] In a respiration analysis system using a gas image detection method according to the present disclosure, respiration of a subject can be measured in a non-contact manner by capturing a thermogram image of exhalation of the subject by using an infrared camera and quantifying the respiration by using the captured image.

[0018] Also, not only the respiration but also hypopnea can be determined by quantifying volume of exhalation exhaled by the subject, and thus a disease caused by the hypopnea can be inferred.

#### BRIEF DESCRIPTION OF DRAWINGS

[0019] FIG. 1 is a diagram schematically illustrating a respiration analysis system using a gas image detection method, according to an embodiment of the present disclosure.

[0020] FIG. 2 is an example diagram of an image of normal respiration with an air current of 100% captured by an exhalation capturing unit of the respiration analysis system of FIG. 1, and a graph of a temperature of the respiration, respiration volume, and concentration of carbon dioxide according to time.

[0021] FIG. 3 is an example diagram of an image of air current decreased respiration with an air current of 50% captured by the exhalation capturing unit of the respiration analysis system of FIG. 1, and a graph of a temperature of the respiration, respiration volume, and concentration of carbon dioxide according to time.

[0022] FIG. 4 is an example diagram of an image of air current lost respiration with an air current of 0% captured by the exhalation capturing unit of the respiration analysis system of FIG. 1, and a graph of a temperature of the respiration, respiration volume, and concentration of carbon dioxide according to time.

#### BEST MODE

[0023] The present disclosure provides a respiration analysis system using a gas image detection method, the respiration analysis system including: an exhalation capturing unit provided adjacent to a subject and capturing an image of exhalation exhaled from the mouth and nose of the subject; and a control unit electrically connected to the exhalation capturing unit, and calculating and storing, as data, a respiration cycle and respiration volume from the image captured through the exhalation capturing unit. Accordingly, not only respiration of the subject is measured in a non-contact manner, but also hypopnea is determined by quantifying volume of the exhalation exhaled by the subject, thereby inferring a disease caused by the hypopnea.

#### Mode of the Invention

[0024] Hereinafter, the present disclosure will be described more fully with reference to the accompanying drawings, in which exemplary embodiments of the present disclosure are shown. The terms or words used herein must not be interpreted in their common or dictionary definitions, but must be interpreted in the meanings and concept corresponding to the aspect of the present disclosure, based on the principle that the inventor(s) can suitably define the concept of terms in order to describe the present disclosure in the best manner.

[0025] Accordingly, the embodiments and drawings described herein are only preferred examples, and do not represent the technical aspects of the present disclosure. Thus, one of ordinary skill in the art understands that the present disclosure may be embodied in many different forms.

[0026] The present disclosure relates to a respiration analysis system using a gas image detection method, in which an image of exhalation of a subject is captured with a gas image detection infrared camera, respiration is quantified by using the captured image, and respiration of the subject, a respiration volume, and a respiration component are measured by using a quantitative difference of the respiration or a change in a temperature or the like, and will now be described with reference to accompanying drawings.

[0027] FIG. 1 is a diagram schematically illustrating a respiration analysis system using a gas image detection method, according to an embodiment of the present disclosure, FIG. 2 is an example diagram of an image of normal respiration with an air current of 100% captured by an exhalation capturing unit of the respiration analysis system of FIG. 1, and a graph of a temperature of the respiration, respiration volume, and concentration of carbon dioxide according to time, FIG. 3 is an example diagram of an image of air current decreased respiration with an air current of 50% captured by the exhalation capturing unit of the respiration analysis system of FIG. 1, and a graph of a temperature of the respiration, respiration volume, and concentration of carbon dioxide according to time, and FIG. 4 is an example diagram of an image of air current lost respiration with an air current of 0% captured by the exhalation capturing unit of the respiration analysis system of FIG. 1, and a graph of a temperature of the respiration, respiration volume, and concentration of carbon dioxide according to time.

[0028] Referring to FIG. 1, the respiration analysis system using the gas image detection method, according to an embodiment of the present disclosure includes an exhalation capturing unit 30 and a control unit 40, and in addition, may further include a measuring bed 10, a bio-signal measuring unit 20, and a display unit 50.

[0029] First, referring to the exhalation capturing unit 30 according to an embodiment of the present disclosure in detail, as shown in FIG. 1, the exhalation capturing unit 30 is provided around the face of the subject to capture an image of exhalation exhaled from the mouth and nose of the subject.

[0030] Here, the exhalation capturing unit 30 may capture a thermogram image in which a color or color density around the mouth and nose of the subject is changed according to changes in a temperature and humidity according to the exhalation exhaled from the mouth and nose of the subject, or capture a thermogram image in which a color or color density around the mouth and nose of the subject is changed according to a distribution of carbon dioxide in the exhalation exhaled from the mouth and nose of the subject, by using an infrared camera, as shown in FIGS. 2 and 3.

[0031] The thermogram image captured by using the infrared camera denotes an image in which a temperature distribution of a certain surface obtained via measurement of infrared rays emitted from the certain surface is displayed in light and shade of black and white or in colors, and the exhalation capturing unit 30 according to an embodiment of the present disclosure may capture the thermogram image of

the changes in temperature and humidity according to the exhalation around the mouth and nose of the subject, via the infrared rays emitted from the exhalation exhaled from the mouth and nose of the subject.

**[0032]** In addition, the thermogram image of the distribution of carbon dioxide that is a selected gas in the exhalation exhaled from the mouth and nose of the subject may be captured via infrared filtering of a certain frequency band.

**[0033]** Also, a plurality of the exhalation capturing units **30** may be provided on a holder **11** to capture an image of the exhalation on an orthogonal line based on the face of the subject, and according to an embodiment of the present disclosure of FIG. 1, the exhalation capturing unit **30** may be provided on each of the front and side of the face of the subject to capture the image of the exhalation exhaled from the mouth and nose of the subject from each of the front and side of the face of the subject.

**[0034]** At this time, the exhalation capturing unit **30** may track and move along the face of the subject, along a length direction.

**[0035]** The exhalation capturing unit **30** described above is electrically connected to the control unit **40** and transmits the captured thermogram image to the control unit **40**, and the control unit **40** is capable of data communication by being electrically connected to the exhalation capturing unit **30** and processes and stores the thermogram image while receiving the image captured by the exhalation capturing unit **30**.

**[0036]** Here, the control unit **40** processes the thermogram image that is the image captured through the exhalation capturing unit **30** such that the respiration is quantified, and at this time, to quantify the respiration, the control unit **40** divides the captured thermogram image according to frames, selects a region around the nose and mouth of the subject as a measurement region from each frame, virtually divides the selected measurement region into lattices of respective sizes as a criterion of the measurement region, counts the number of lattices whose color is changed according to the respiration of the subject in the measurement region divided into the plurality of lattices, calculates a color density changed degree of the lattices whose color is changed, and stores the color density changed degree as data according to time.

**[0037]** Accordingly, the respiration may be determined based on the color change around the mouth and nose of the subject via the thermogram image, and the respiration may be quantified because the respiration volume may be determined based on the number of lattices whose color is changed and on the color density.

**[0038]** When the respiration is quantified via the above processes, the subject is able to compare the respiration, a respiration cycle, and the respiration volume based on the data, and thus the apnea of the subject may be inferred.

**[0039]** In addition, the measuring bed **10** may include a base provided on the ground, such as a general bed, and a mattress provided on the base and on which the subject lies.

**[0040]** Also, the holder **11** holding the exhalation capturing unit **30** is provided at the measuring bed **10**, wherein the holder **11** is located at a head position of the subject at the measuring bed **10** such that the exhalation capturing unit **30** is located around the face of the subject.

**[0041]** Here, the holder **11** may be moved by a moving unit **12** provided at the measuring bed **10** such that the face of the subject is traced and photographed at the measuring bed **10**.

**[0042]** Here, regarding the moving of the holder **11**, an operator may manually move the holder **11** and the exhalation capturing unit **30** by directly manipulating a manipulating unit, such as a joystick or the like, or the holder **11** and the exhalation capturing unit **30** may automatically move by tracking the face of the subject according to location coordinates displacement of the face of the subject extracted based on the image captured by the exhalation capturing unit **30**.

**[0043]** A moving screw may be used as the moving unit **12** moving the holder **11**, and a linear motor or the like may be used for the exhalation capturing unit **30** moving along a length direction of the holder **11**, but the present disclosure is not limited thereto.

**[0044]** Also, the bio-signal measuring unit **20** may be mounted on the body of the subject and measure the bio-signal of the subject.

**[0045]** Here, the bio-signal measuring unit **20** may include a brainwave measuring sensor **21** mounted on the head of the subject and measuring brainwaves of the subject, a temperature measuring sensor **22** mounted on the body of the subject and measuring the temperature of the subject, and a pulse measuring sensor **23** mounted on the body of the subject and measuring a pulse of the subject. At least one type of the above measuring sensors may be mounted on the body of the subject as occasion demands, and a measurement value thereof may be transmitted to the control unit **40**.

**[0046]** The bio-signal of the subject measured by the bio-signal measuring unit **20** according to an embodiment of the present disclosure is transmitted to the control unit **40** that is electrically connected to the bio-signal measuring unit **20** to enable data communication.

**[0047]** Also, the bio-signal measuring unit **20** according to an embodiment of the present disclosure is described limitedly to the brainwave measuring sensor **21**, the temperature measuring sensor **22**, and the pulse measuring sensor **23**, but is not limited thereto, and may further include an electrocardiogram (ECG) measuring sensor for measuring a cycle and degree of heartbeats.

**[0048]** Also, the display unit **50** according to an embodiment of the present disclosure is electrically connected to the exhalation capturing unit **30** and the control unit **40**, displays data of the bio-signal stored in the control unit **40**, and displays the captured image of the exhalation.

**[0049]** FIGS. 2 through 4 illustrate images of respiration of air currents of 100%, 50%, and 0% captured by an exhalation capturing unit of a respiration analysis system according to an embodiment of the present disclosure, and graphs of a temperature, respiration volume, and concentration of carbon dioxide of the respiration according to time. An image of exhalation of a subject may be captured by a gas image detection infrared camera, respiration may be quantified by using the captured image, and a disease related to the respiration may be inferred based on quantified data.

**[0050]** A respiration analysis system using a gas image detection method, according to an embodiment of the present disclosure is not only used to diagnose snoring or sleep apnea, but to monitor respiration and respiration volume of a risk group, such as an infant, a critical patient, or an aged citizen, as well as a normal person, and is able to measure a respiration change of a subject without the subject having to wear a separate device not only when the subject is sleeping, but also when the subject is awake.

**[0051]** In addition, it is possible to measure the number of breathings and a respiration cycle, distinguish breathing and coughing, and measure a coughing degree, according to existence of respiration, quantification of respiration, and shape and speed of an air current, and it is also possible to diagnose a disease by medically analysing a respiration component of a person. For example, nitric oxide (NO) in the exhalation (expiration) of a person is increased due to a respiratory infection, such as asthma, and thus by measuring NO, a respiratory disease (cold, asthma, or the like) may be screened.

**[0052]** As such, a respiratory disease may be diagnosed in a non-contact manner, and by mounting a miniature infrared camera to a smart phone or using an infrared camera mounted on a personal computer (PC), a patient may be examined and analyzed in real-time for remote medical diagnosis.

**[0053]** Also, a respiration analysis system using a gas image detection method, according to an embodiment of the present disclosure may measure a gas of different components according to a wavelength of infrared rays used in a camera, and for example, an alcohol component in respiration is measured by using a camera of a wavelength capable of measuring ethanol, and thus drunk driving may be indirectly determined by determining drinking in a non-contact manner.

**[0054]** Also, a respiration analysis system using a gas image detection method, according to an embodiment of the present disclosure may be configured as a wearable device, such as a head-mounted display (HMD) or Google glass, in which an exhalation capturing unit capturing an image of exhalation of a subject, a control unit calculating and storing, as data, a respiration cycle and respiration volume by using the captured image, and a display unit displaying data according to a bio-signal and displaying the image of exhalation that is to be captured or is captured are integrated as one body, thereby enabling not only non-contact medical diagnosis, but also remote medical diagnosis using a communication unit.

**[0055]** While the present disclosure has been particularly shown and described with reference to exemplary embodiments thereof, it will be understood by those of ordinary skill in the art that various changes in form and details may be made therein without departing from the spirit and scope of the present disclosure as defined by the following claims.

1. A respiration analysis system using a gas image detection method, the respiration analysis system comprising:  
 an exhalation capturing unit provided adjacent to a subject and capturing an image of exhalation exhaled from the mouth and nose of the subject; and  
 a control unit electrically connected to the exhalation capturing unit, and calculating and storing, as data, a

respiration cycle and respiration volume from the image captured through the exhalation capturing unit.

2. The respiration analysis system of claim 1, wherein the exhalation capturing unit captures a thermogram image in which a color or color density is changed according to changes in a temperature and humidity according to the exhalation exhaled from the mouth and nose of the subject, by using an infrared camera.

3. The respiration analysis system of claim 1, wherein the exhalation capturing unit captures a thermogram image in which a color or color density is changed according to a distribution of carbon dioxide in the exhalation exhaled from the mouth and nose of the subject, by using an infrared camera.

4. The respiration analysis system of claim 2, wherein a plurality of the exhalation capturing units are provided to capture an image of the exhalation on an orthogonal line based on the face of the subject.

5. The respiration analysis system of claim 1, further comprising a bio-signal measuring unit electrically connected to the control unit to be mounted on the body of the subject and measuring a bio-signal of the subject.

6. The respiration analysis system of claim 5, wherein the bio-signal measuring unit comprises:

a brainwave measuring sensor mounted on the head of the subject and measuring brainwaves of the subject;

a temperature measuring sensor mounted on the body of the subject and measuring a temperature of the subject; and

a pulse measuring sensor mounted on the body of the subject and measuring a pulse of the subject.

7. The respiration analysis system of claim 1, further comprising a display unit electrically connected to the exhalation capturing unit and the control unit, display data according to a bio-signal stored in the control unit, and display the image of exhalation, which is to be captured or is captured.

8. The respiration analysis system of claim 7, wherein the exhalation capturing unit, the control unit, and the display unit are integrated in one body and configured as a wearable device mounted on the head or body of an observer observing the respiration of the subject.

9. The respiration analysis system of claim 3, wherein a plurality of the exhalation capturing units are provided to capture an image of the exhalation on an orthogonal line based on the face of the subject.

\* \* \* \* \*

专利名称(译)	使用气体图像检测方法的呼吸分析系统		
公开(公告)号	<a href="#">US20190274621A1</a>	公开(公告)日	2019-09-12
申请号	US16/345230	申请日	2017-09-29
申请(专利权)人(译)	亚洲大学产学合作基础		
当前申请(专利权)人(译)	亚洲大学产学合作基础		
[标]发明人	KIM HYUN JUN		
发明人	KIM, HYUN JUN		
IPC分类号	A61B5/00 A61B5/0205 A61B5/01 A61B5/0476		
CPC分类号	A61B5/0075 A61B5/024 A61B5/6801 A61B5/0476 A61B5/01 A61B5/0816 A61B5/4818 A61B5/02055 A61B5/091 A61B5/742 A61B5/0836 A61B5/0022 A61B5/0077 A61B5/015 A61B5/0478 A61B5/0826 A61B5/1032 A61B2562/04 A61B5/00 A61B5/08 G16H40/67 H04N5/33 A61B5/02444		
优先权	1020160141615 2016-10-28 KR		
外部链接	<a href="#">Espacenet</a> <a href="#">USPTO</a>		

摘要(译)

提供一种使用气体图像检测方法的呼吸分析系统，该呼吸分析系统包括：呼气捕获单元，其设置在对象附近并且捕获从对象的嘴和鼻呼出的呼气图像；控制单元电连接到呼气捕获单元，并且从通过呼气捕获单元捕获的图像计算和存储呼吸循环和呼吸量作为数据。因此，提供了使用气体图像检测方法的呼吸分析系统，其中不仅以非接触方式测量受试者的呼吸，而且通过量化受试者呼出的呼气的体积来确定呼吸不足，从而推断由呼吸不足引起的疾病。

