



US 20190254538A1

(19) **United States**

(12) **Patent Application Publication**
Erdman et al.

(10) **Pub. No.: US 2019/0254538 A1**

(43) **Pub. Date: Aug. 22, 2019**

(54) **BREATH SAMPLING MASK AND SYSTEM**

Publication Classification

(71) Applicants: **REGENTS OF THE UNIVERSITY OF MINNESOTA**, Minneapolis, MN (US); **Boston Scientific Scimed, Inc.**, Maple Grove, MN (US)

(51) **Int. Cl.**
A61B 5/0205 (2006.01)
A61B 5/00 (2006.01)
(52) **U.S. Cl.**
CPC *A61B 5/02055* (2013.01); *A61B 5/02438* (2013.01); *A61B 5/6803* (2013.01)

(72) Inventors: **Arthur Guy Erdman**, New Brighton, MN (US); **Gregory J. Sherwood**, North Oaks, MN (US); **Gregory Kermit Peterson**, North Oaks, MN (US); **Justin Theodore Nelson**, Minneapolis, MN (US); **Michael Mathias Freking**, Arden Hills, MN (US)

(57) **ABSTRACT**

Embodiments herein include a breath sampling mask, systems, and related methods. In an embodiment, a breath sensing system is included. The breath sensing system can include a breath sampling mask. The breath sampling mask can include a mask housing configured to cover a portion of the face of a patient. The mask housing can define a breath receiving chamber. The breath sampling mask can include a chemical sensor element in fluid communication with the breath sampling mask, where the chemical sensor element can include a plurality of discrete binding detectors. The chemical sensor element can interface with a breath sample collected through the breath sampling mask. Other embodiments are also included herein.

(21) Appl. No.: **16/280,644**

(22) Filed: **Feb. 20, 2019**

Related U.S. Application Data

(60) Provisional application No. 62/632,552, filed on Feb. 20, 2018.

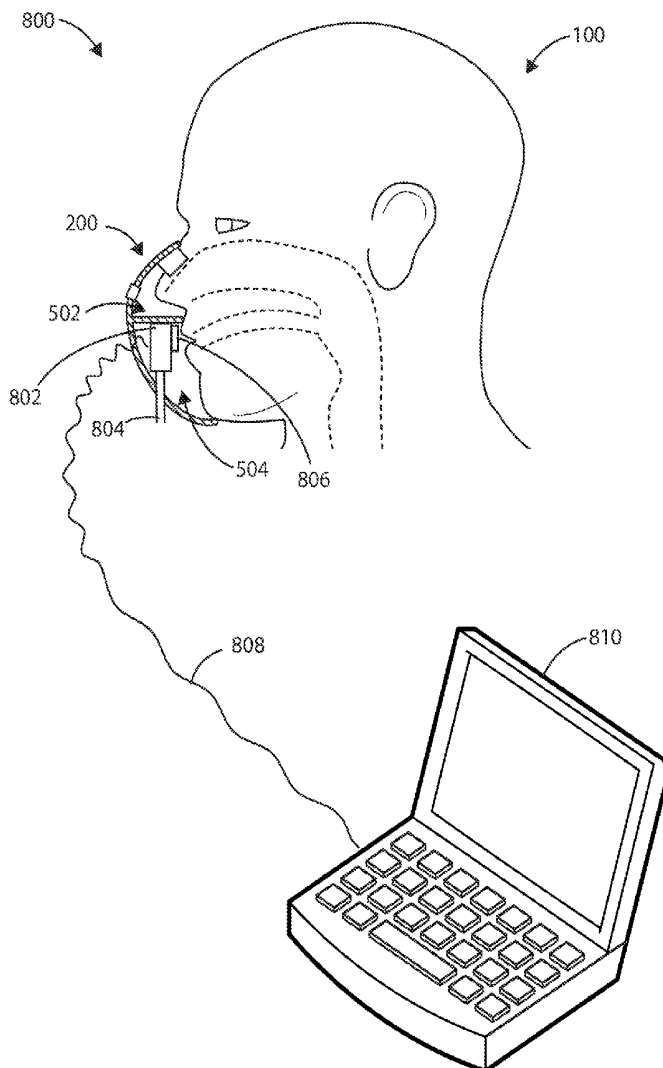

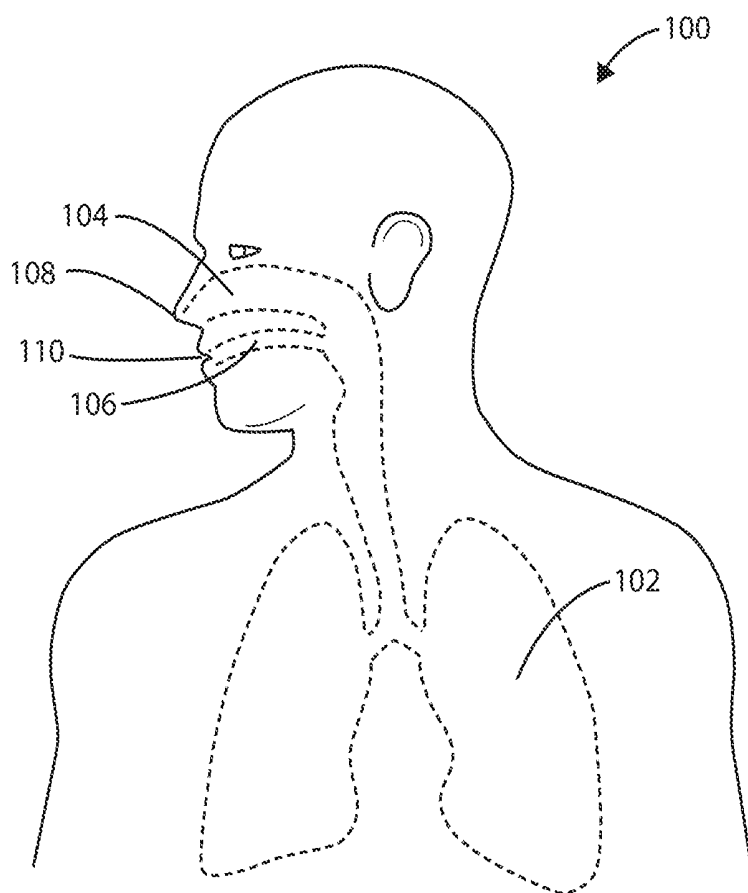

FIG. 1

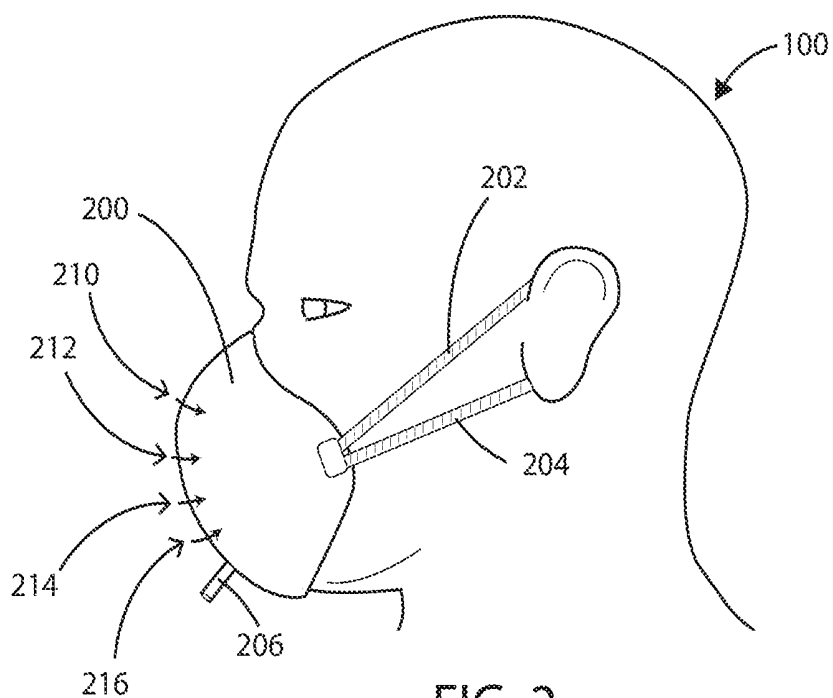

FIG. 2

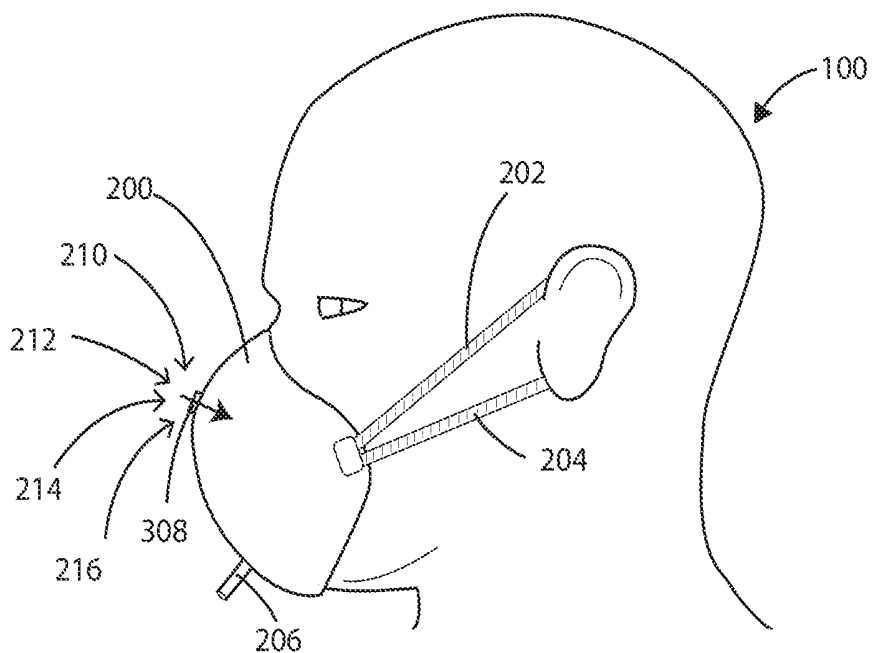

FIG. 3

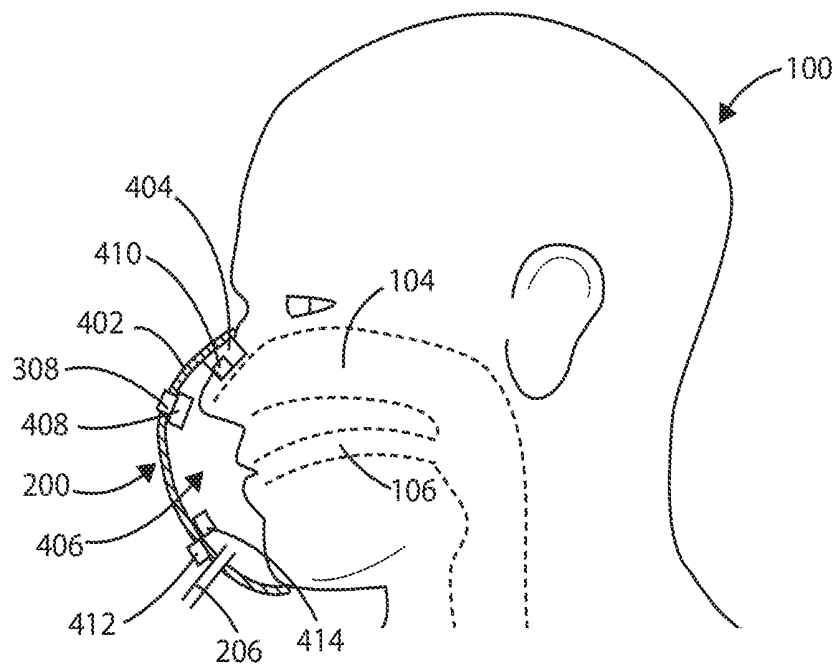

FIG. 4

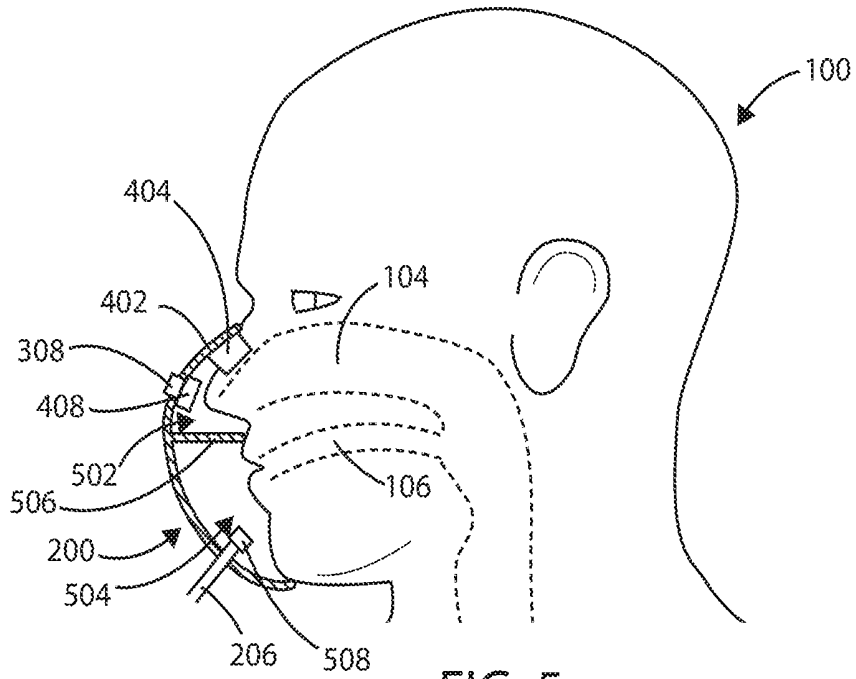

FIG. 5

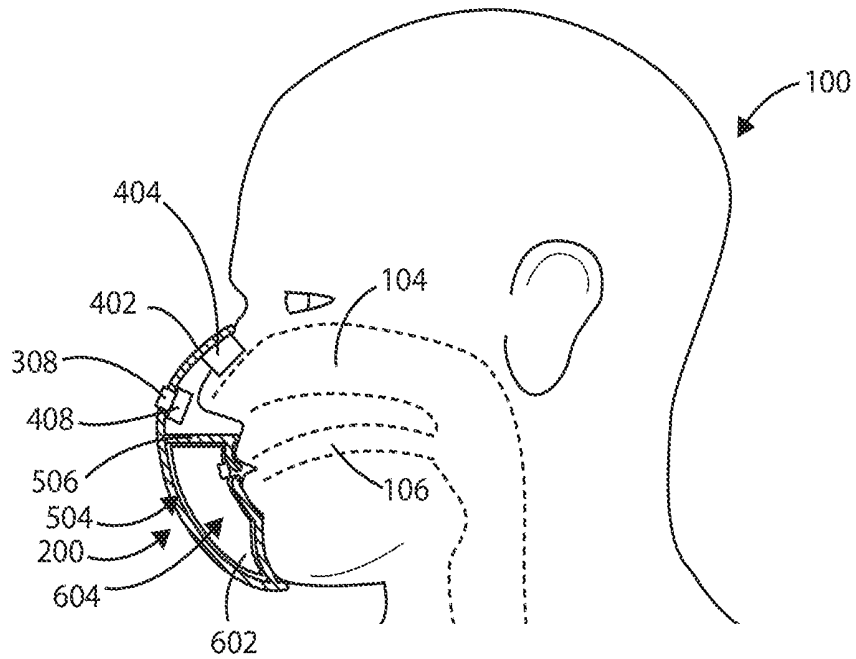

FIG. 6

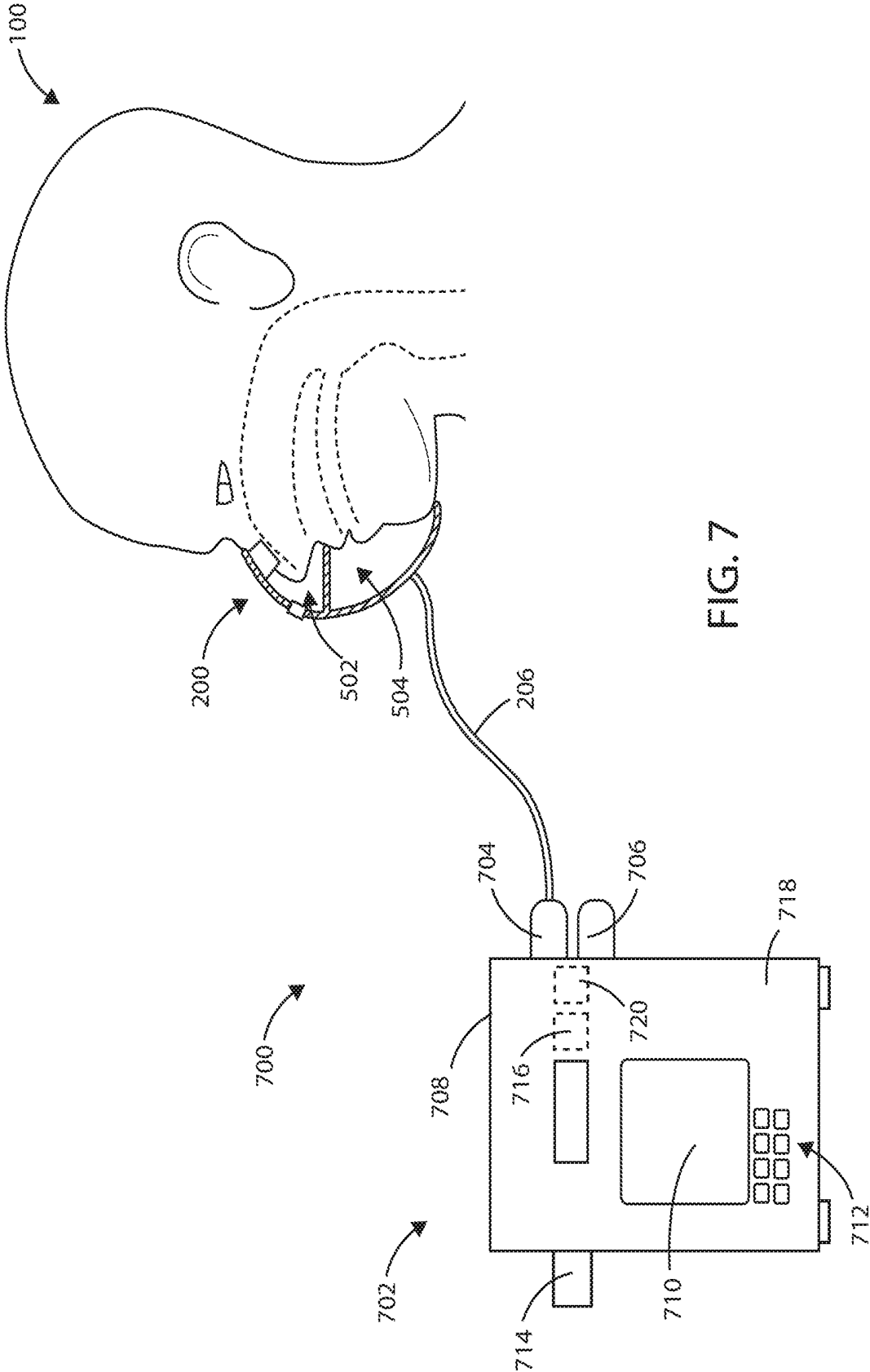

FIG. 7

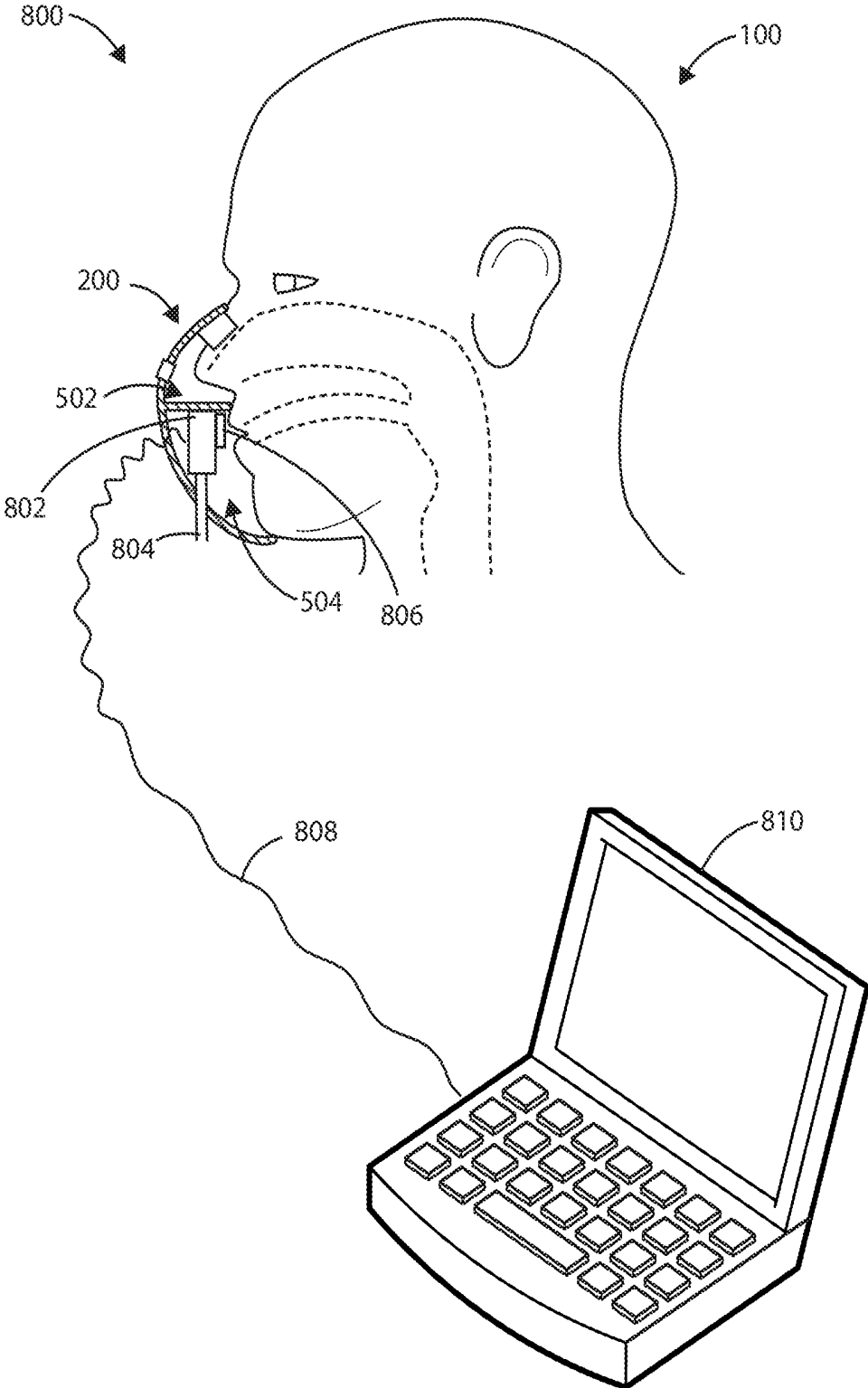

FIG. 8

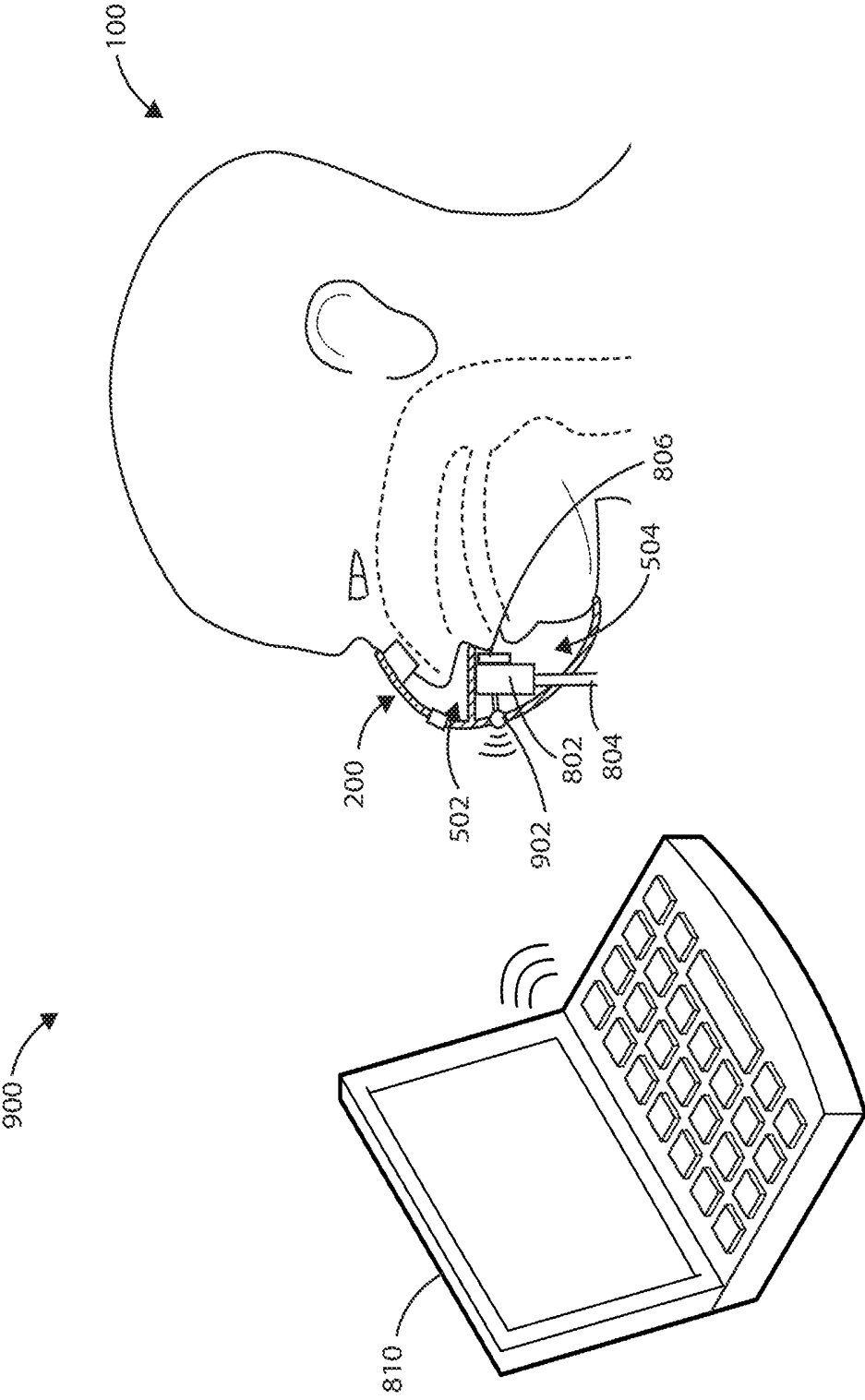

FIG. 9

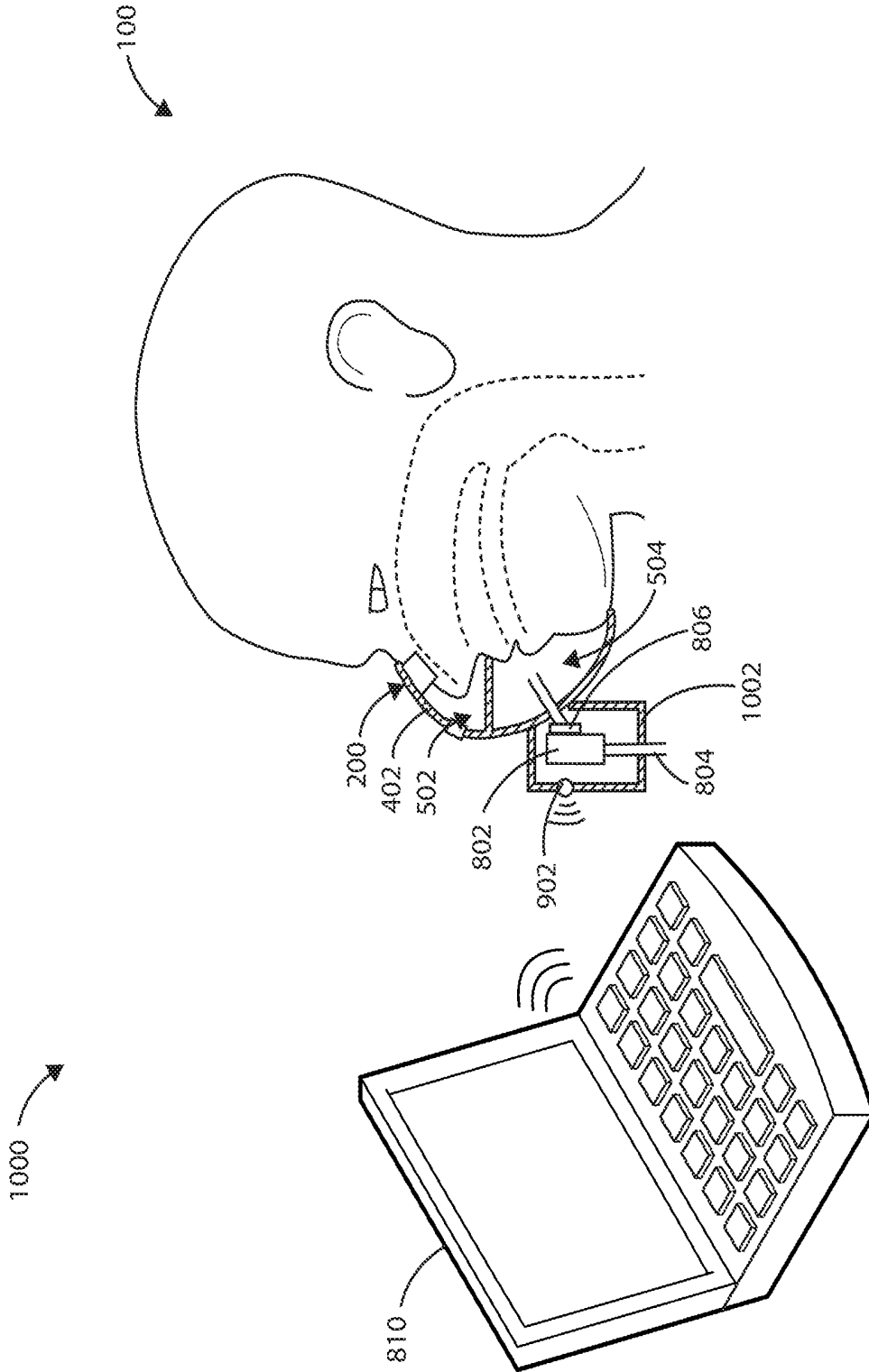

FIG. 10

FIG. 11

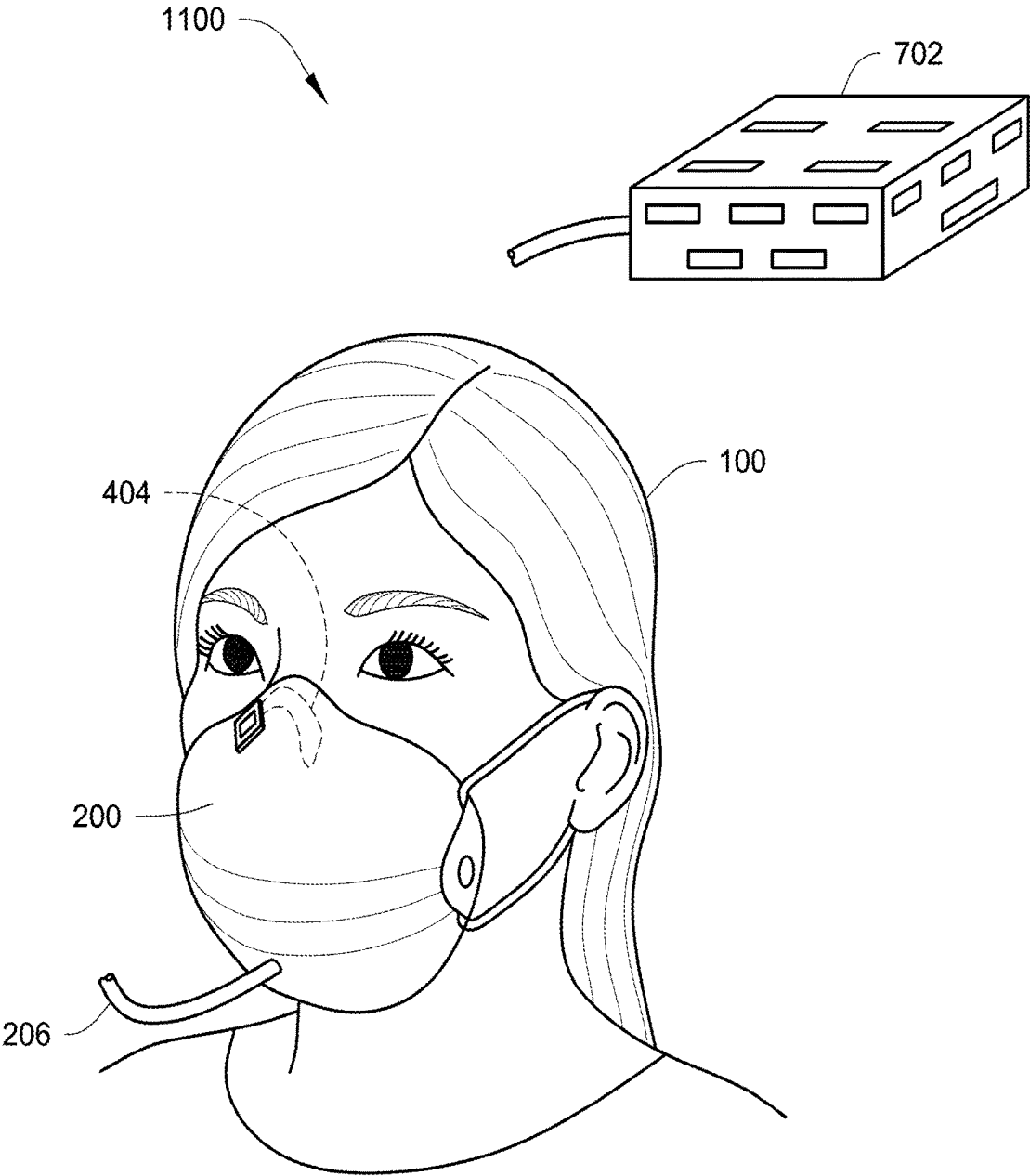

FIG. 12

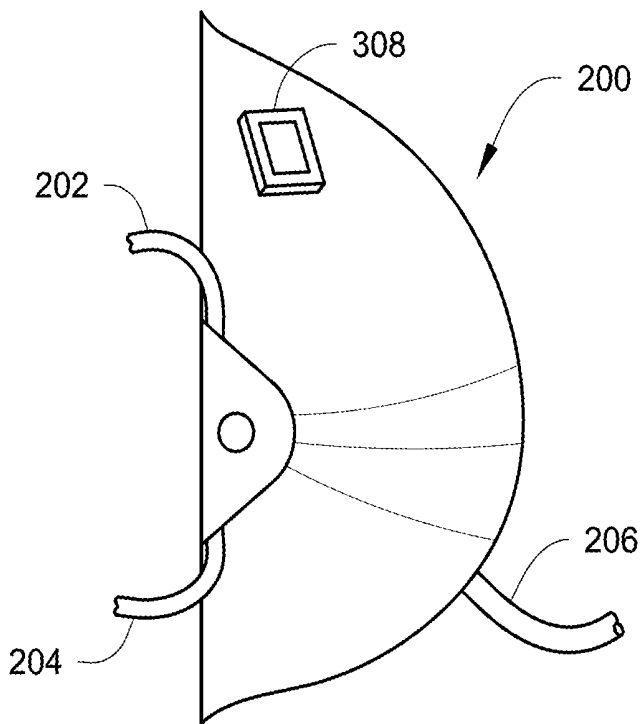

FIG. 13

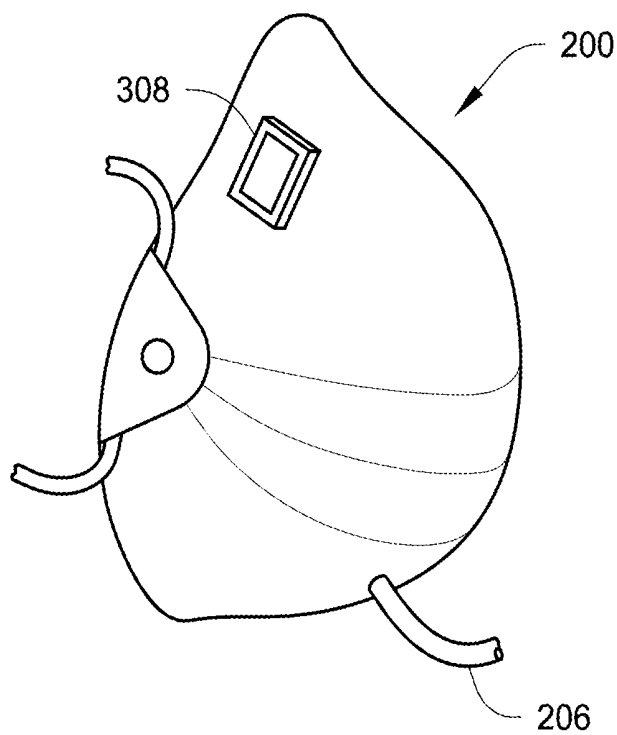

FIG. 14

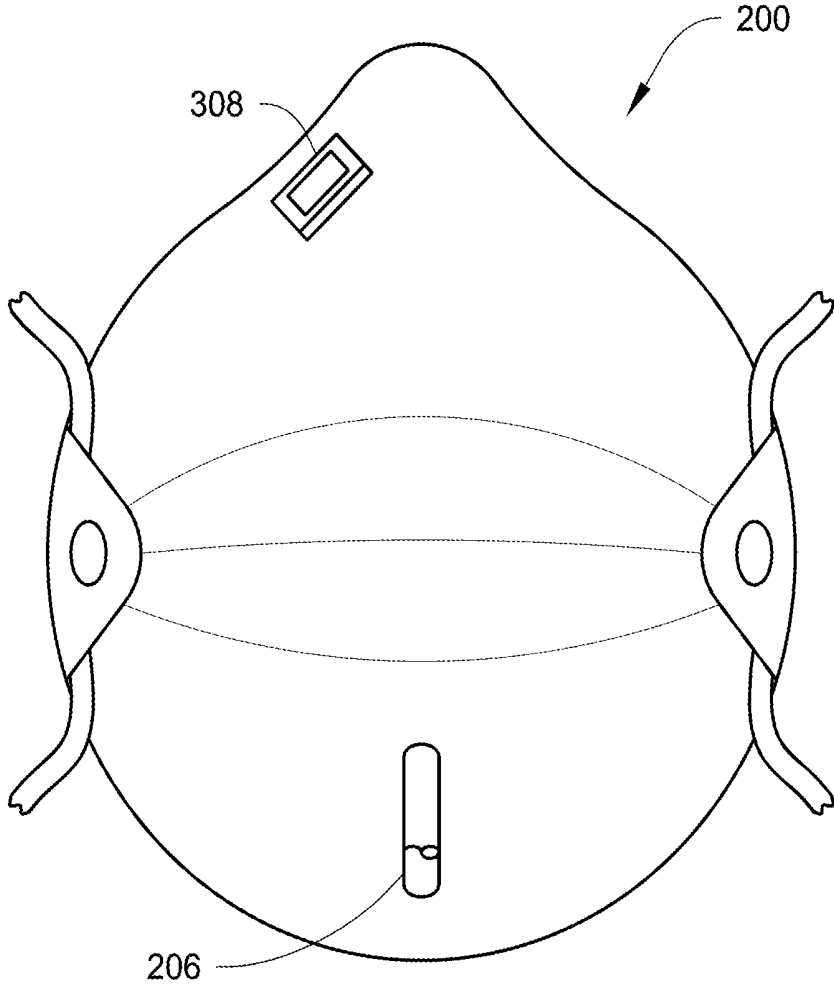

FIG. 15

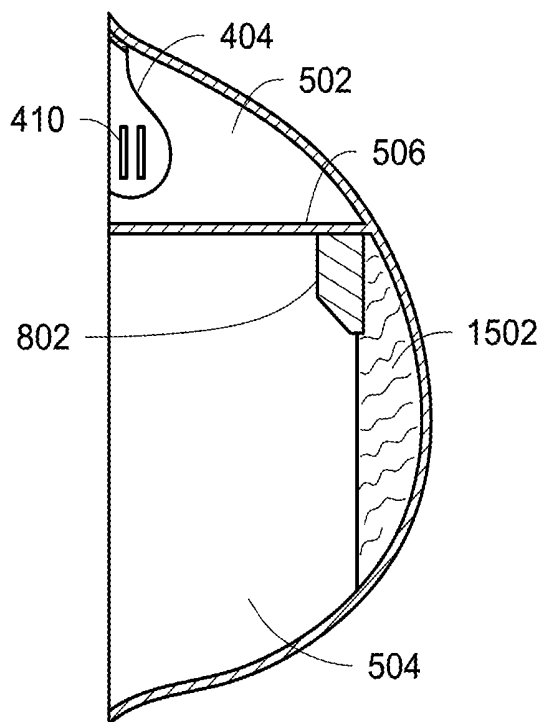

FIG. 16

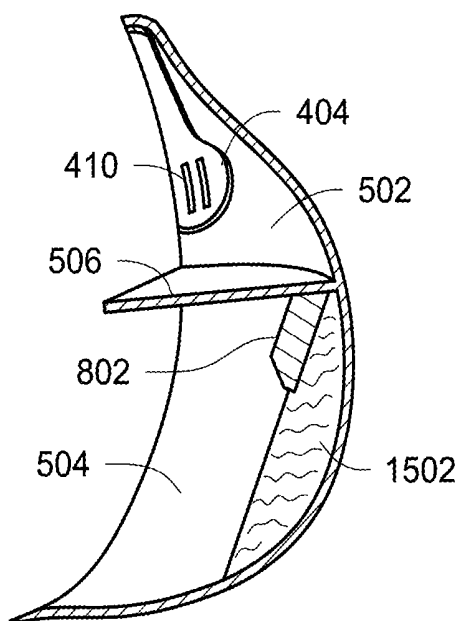
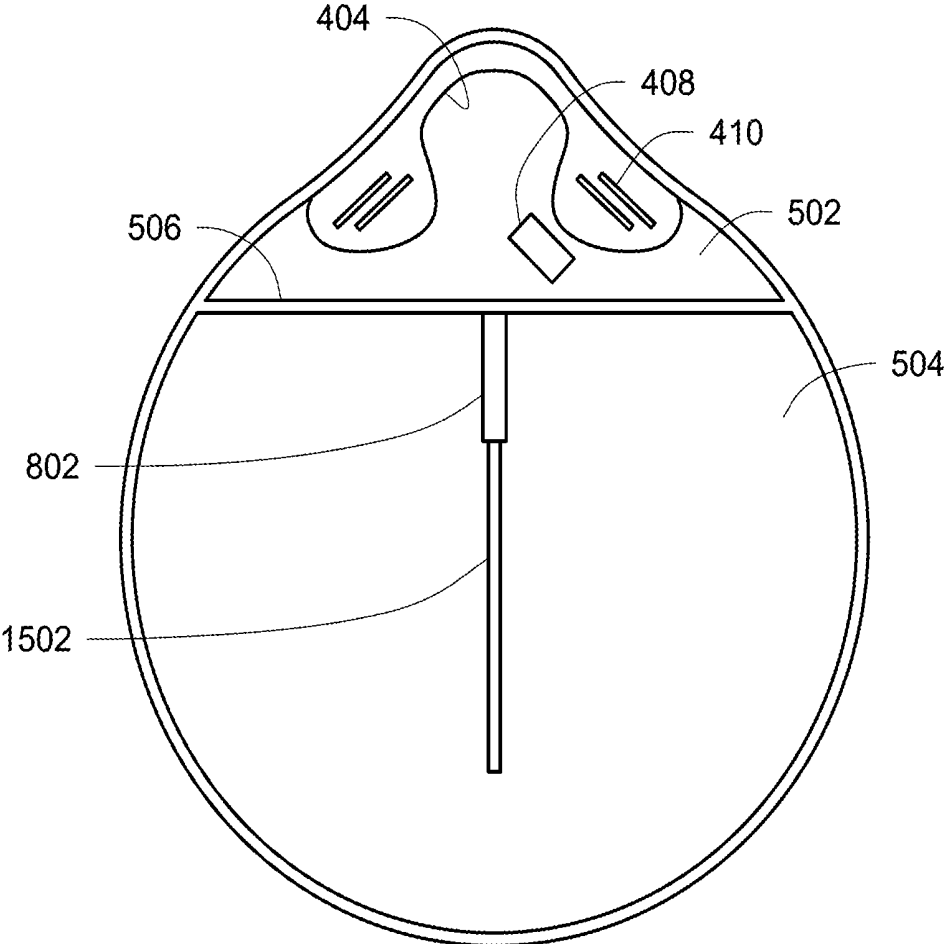

FIG. 17



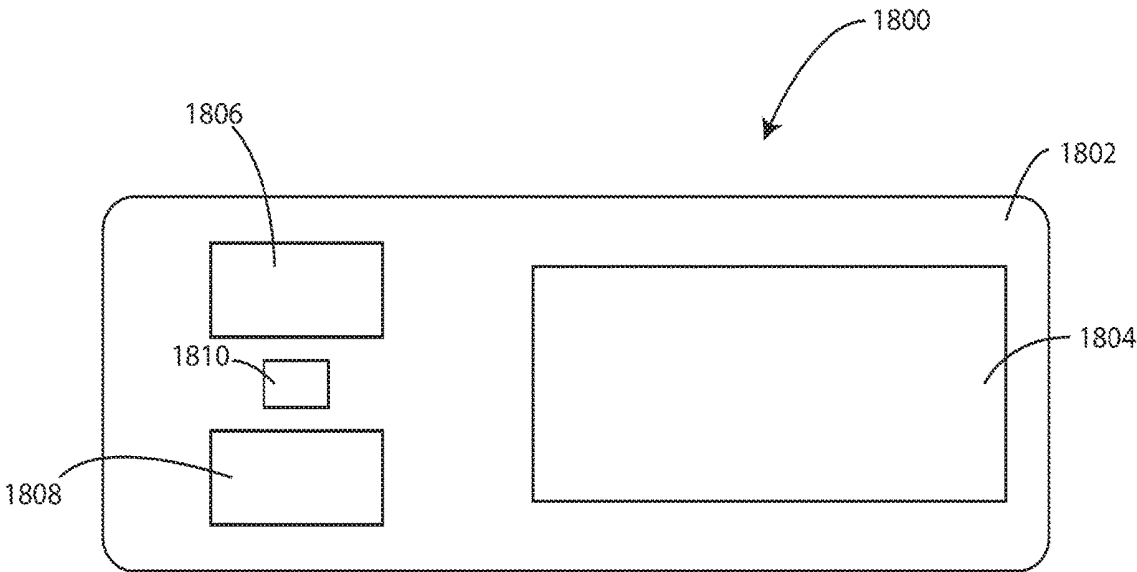

FIG. 18

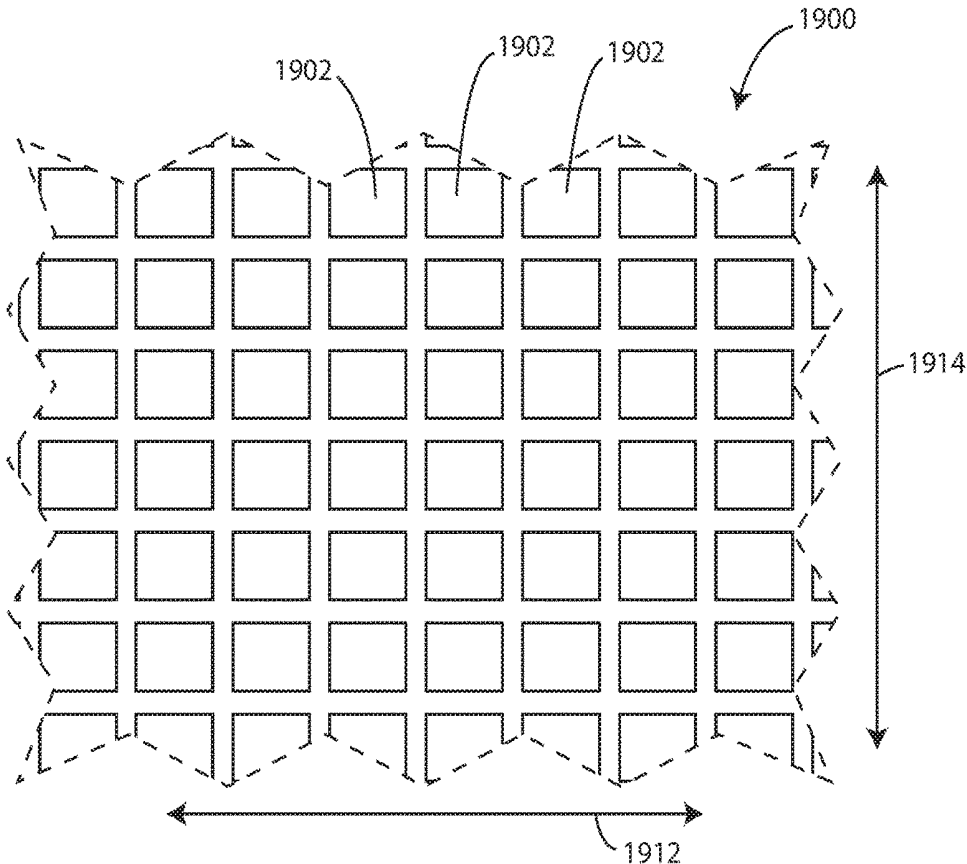

FIG. 19

DSD 115.0323USU1 (18-0034US01)

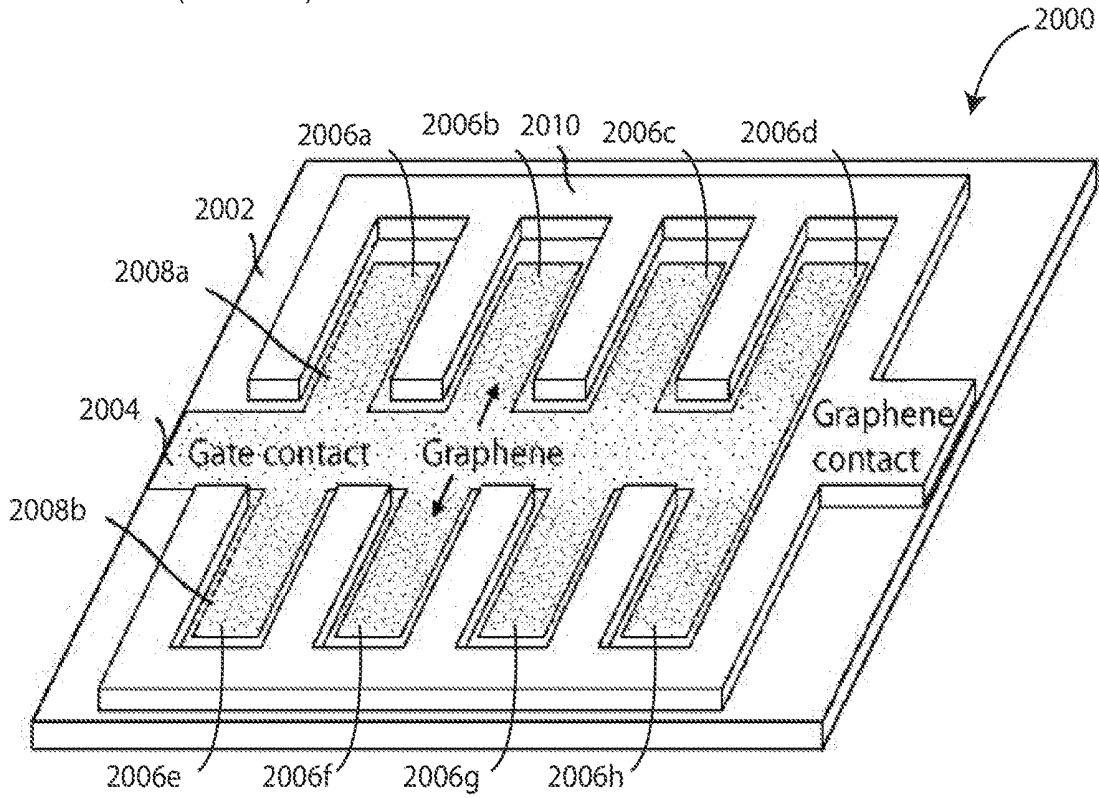

FIG. 20

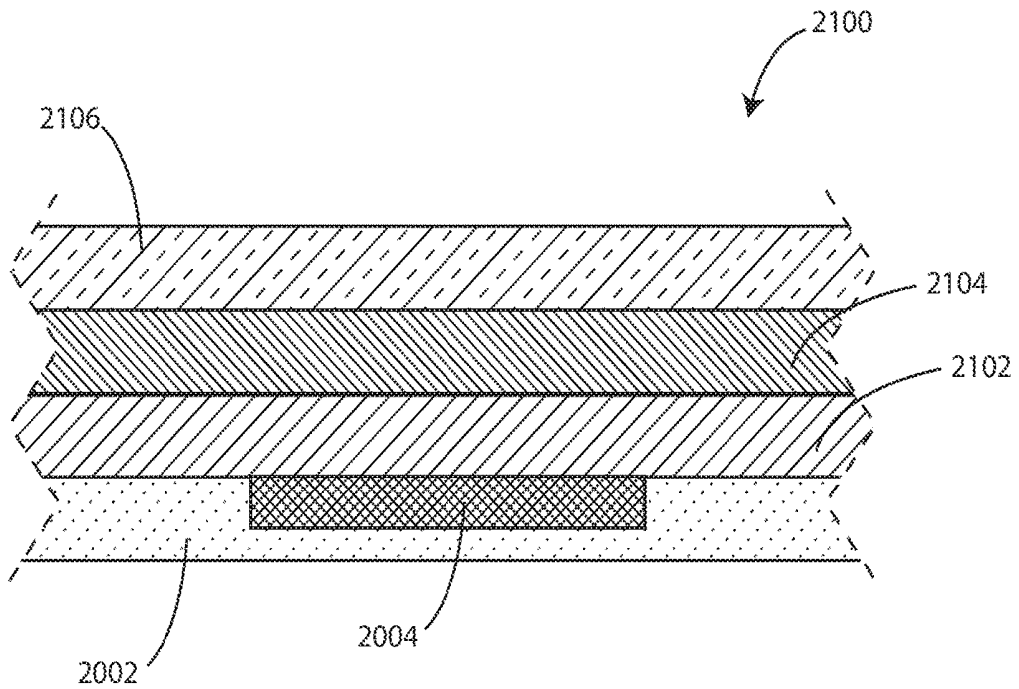

FIG. 21

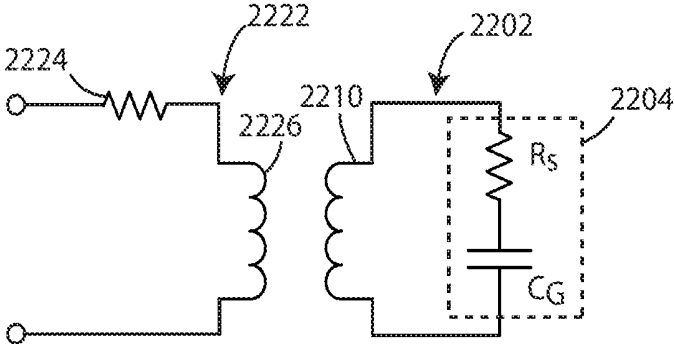

FIG. 22

BREATH SAMPLING MASK AND SYSTEM

[0001] This application claims the benefit of U.S. Provisional Application No. 62/632,552, filed Feb. 20, 2018, the content of which is herein incorporated by reference in its entirety.

FIELD OF THE TECHNOLOGY

[0002] The present application relates to a breath sampling mask and systems and methods related to the same.

BACKGROUND

[0003] The accurate detection of diseases can allow clinicians to provide appropriate therapeutic interventions. The early detection of diseases can lead to better treatment outcomes. Diseases can be detected using many different techniques including analyzing tissue samples, analyzing various bodily fluids, diagnostic scans, genetic sequencing, and the like.

[0004] Some disease states result in the production of specific chemical compounds. In some cases, volatile organic compounds (VOCs) released into a gaseous sample of a patient can be hallmarks of certain diseases. The detection of these compounds or differential sensing of the same can allow for the early detection of particular disease states.

[0005] The breath of a patient provides an ideal gas for diagnostic sampling purposes. As a part of tidal respiration, air is drawn in through the nose and/or mouth and into the lungs. By its presence in close contact with moist internal tissues, the inspired air is warmed, humidified, and picks up volatile organic compounds. This air is then expired out through the nose and/or mouth.

SUMMARY

[0006] In a first aspect, a breath sensing system is included. The breath sampling system can include a breath sampling mask. The breath sampling mask can include a mask housing configured to cover a portion of the face of a patient, the mask housing defining a breath receiving chamber. The breath sampling system can also include a chemical sensor element in fluid communication with the breath sampling mask. The chemical sensor element can include a plurality of discrete binding detectors. The chemical sensor element can be configured to interface with a breath sample collected through the breath sampling mask.

[0007] In a second aspect, in addition to one or more of the preceding or following aspects, or in the alternative to some aspects, the breath sensing system can include circuitry for generating signals from the discrete binding detectors.

[0008] In a third aspect, in addition to one or more of the preceding or following aspects, or in the alternative to some aspects, the breath sensing system can include a breath sampling mask including a nose clip for helping to secure the breath sampling mask to the face of a patient.

[0009] In a fourth aspect, in addition to one or more of the preceding or following aspects, or in the alternative to some aspects, the breath sensing system can include a sensor such as one or more of a temperature sensor, a heart rate sensor, and a blood pressure sensor.

[0010] In a fifth aspect, in addition to one or more of the preceding or following aspects, or in the alternative to some aspects, the breath sensing system can include a sensor such

as one or more of an ambient temperature sensor, an ambient humidity sensor, an internal temperature sensor, and an internal humidity sensor.

[0011] In a sixth aspect, in addition to one or more of the preceding or following aspects, or in the alternative to some aspects, the breath sensing system can include a removable breath sample container disposed within the mouth chamber.

[0012] In a seventh aspect, in addition to one or more of the preceding or following aspects, or in the alternative to some aspects, the breath sensing system can include a gas outflow conduit in fluid communication with the breath receiving chamber.

[0013] In an eighth aspect, in addition to one or more of the preceding or following aspects, or in the alternative to some aspects, the breath sensing system can include a chemical sensor holder configured to allow removable mounting of a chemical sensor element.

[0014] In a ninth aspect, in addition to one or more of the preceding or following aspects, or in the alternative to some aspects, the chemical sensor holder can be disposed within the breath receiving chamber.

[0015] In a tenth aspect, in addition to one or more of the preceding or following aspects, or in the alternative to some aspects, the breath sensing system can include a chemical sensor holder housing in fluid communication with the breath receiving chamber, wherein the chemical sensor element can be disposed within the chemical sensor holder housing.

[0016] In an eleventh aspect, in addition to one or more of the preceding or following aspects, or in the alternative to some aspects, the breath sensing system can include a filter in fluid communication with the one-way airflow valve.

[0017] In a twelfth aspect, in addition to one or more of the preceding or following aspects, or in the alternative to some aspects, a breath sampling mask is included. The breath sampling mask can include a mask housing configured to cover a portion of the face of a patient. The mask housing can define a chamber. The mask configured to remove volatile organic compounds from air drawn in through the mask housing.

[0018] In a thirteenth aspect, in addition to one or more of the preceding or following aspects, or in the alternative to some aspects, the breath sampling mask can include a sensor such as one or more of a temperature sensor, a heart rate sensor, and a blood pressure sensor.

[0019] In a fourteenth aspect, in addition to one or more of the preceding or following aspects, or in the alternative to some aspects, the breath sampling mask can include a nose clip member for helping to secure the breath sampling mask to the patient.

[0020] In a fifteenth aspect, in addition to one or more of the preceding or following aspects, or in the alternative to some aspects, a sensor can be attached to a nose clip member.

[0021] In a sixteenth aspect, in addition to one or more of the preceding or following aspects, or in the alternative to some aspects, the mask housing of the breath sampling mask can include a dividing wall isolating the chamber into a nasal chamber and a mouth chamber.

[0022] In a seventeenth aspect, in addition to one or more of the preceding or following aspects, or in the alternative to some aspects, the breath sampling mask can include a one-way airflow valve in fluid communication with the nasal chamber and an area outside of the mask housing, where the

one-way airflow valve only allows a flow of air from the area outside of the mask housing into the nasal chamber.

[0023] In an eighteenth aspect, in addition to one or more of the preceding or following aspects, or in the alternative to some aspects, the breath sampling mask can include a chemical sensor holder configured to allow removable mounting of a chemical sensor element. The chemical sensor holder can be disposed within the mouth chamber of the breath sampling mask.

[0024] In a nineteenth aspect, in addition to one or more of the preceding or following aspects, or in the alternative to some aspects, the breath sampling mask can include a sensor such as one or more of an ambient temperature sensor, an ambient humidity sensor, an internal temperature sensor, and an internal humidity sensor.

[0025] In a twentieth aspect, in addition to one or more of the preceding or following aspects, or in the alternative to some aspects, a method of determining the presence of one or more disease states of a patient is included. The method can include putting a breath sampling mask on a patient; alerting the patient to breathe in and out to generate a breath sample; contacting the breath sample with a chemical sensor element, the chemical sensor element including a plurality of discrete binding detectors; using a measurement circuit to generate signals from the discrete binding detectors; and evaluating the signals by comparing them to previously obtained sets of signals or signal patterns.

[0026] This summary is an overview of some of the teachings of the present application and is not intended to be an exclusive or exhaustive treatment of the present subject matter. Further details are found in the detailed description and appended claims. Other aspects will be apparent to persons skilled in the art upon reading and understanding the following detailed description and viewing the drawings that form a part thereof, each of which is not to be taken in a limiting sense. The scope of the present application is defined by the appended claims and their legal equivalents.

BRIEF DESCRIPTION OF THE FIGURES

[0027] The technology may be more completely understood in connection with the following drawings, in which:

[0028] FIG. 1 is a schematic view of a patient showing portions of respiratory pathways.

[0029] FIG. 2 is a schematic view of a breath sampling mask as worn by a patient in accordance with various embodiments herein.

[0030] FIG. 3 is a schematic view of a breath sampling mask as worn by a patient in accordance with various embodiments herein.

[0031] FIG. 4 is a schematic cutaway view of a breath sampling mask as worn by a patient in accordance with various embodiments herein.

[0032] FIG. 5 is a schematic cutaway view of a breath sampling mask as worn by a patient in accordance with various embodiments herein.

[0033] FIG. 6 is a schematic cutaway view of a breath sampling mask as worn by a patient in accordance with various embodiments herein.

[0034] FIG. 7 is a schematic view of a breath sampling system in accordance with various embodiments herein.

[0035] FIG. 8 is a schematic view of a breath sampling system in accordance with various embodiments herein.

[0036] FIG. 9 is a schematic view of a breath sampling system in accordance with various embodiments herein.

[0037] FIG. 10 is a schematic view of a breath sampling system in accordance with various embodiments herein.

[0038] FIG. 11 is a schematic view of a breath sampling system in accordance with various embodiments herein.

[0039] FIG. 12 is a schematic view of a breath sampling mask in accordance with various embodiments herein.

[0040] FIG. 13 is a schematic view of a breath sampling mask in accordance with various embodiments herein.

[0041] FIG. 14 is a schematic view of a breath sampling mask in accordance with various embodiments herein.

[0042] FIG. 15 is a schematic cutaway view of a breath sampling mask in accordance with various embodiments herein.

[0043] FIG. 16 is a schematic isometric view of a breath sampling mask in accordance with various embodiments herein.

[0044] FIG. 17 is a schematic bottom plan view of a breath sampling mask in accordance with various embodiments herein.

[0045] FIG. 18 is a schematic top plan view of a chemical sensor element in accordance with various embodiments herein.

[0046] FIG. 19 is a schematic diagram of a portion of a measurement zone in accordance with various embodiments herein.

[0047] FIG. 20 is a schematic perspective view of a graphene varactor in accordance with various embodiments herein.

[0048] FIG. 21 is a schematic cross-sectional view of a portion of a graphene varactor in accordance with various embodiments herein.

[0049] FIG. 22 is a circuit diagram of a passive sensor circuit and a portion of a reading circuit is shown in accordance with various embodiments herein.

[0050] While the technology is susceptible to various modifications and alternative forms, specifics thereof have been shown by way of example and drawings, and will be described in detail. It should be understood, however, that the application is not limited to the particular embodiments described. On the contrary, the application is to cover modifications, equivalents, and alternatives falling within the spirit and scope of the technology.

DETAILED DESCRIPTION

[0051] The breath of a patient provides an ideal gas for diagnostic sampling purposes. As a part of tidal respiration, air is drawn in through the nose and/or mouth and into the lungs. By its presence in close contact with moist internal tissues, the inspired air is warmed, humidified, and picks up volatile organic compounds (VOCs). This air is then expired out through the nose and/or mouth.

[0052] In some instances, the VOCs present in exhaled breath can be hallmarks of certain diseases, including but not limited to cancers, including lung cancer, blood-borne cancers, prostate cancer, rectal cancer, breast cancer, liver cancer, pancreatic cancer, or to other disorders such as chronic obstructive pulmonary disease, diabetes, heart failure, and the like. Detection of VOCs in the breath of a patient directly from the gaseous form can provide an accurate mechanism for determining one or more diseased states.

[0053] Referring now to FIG. 1, a schematic view is shown of a patient 100 showing portions of respiratory pathways. Air can be inspired through the nose 108 and into

nasal passages 104 or through the mouth 110 and into oral passages 106 eventually reaching the lungs 102. The inspired air is warmed, humidified, and picks up volatile organic compounds during its passage to the lungs, while it remains in the lungs, and further during expiration on its way back out of the lungs. The air is then expired through the nasal passages 104 and out the nose 108 and/or through oral passages 106 and out the mouth 110.

[0054] In accordance with various embodiments herein, a breath sampling mask is included which can aid in one or more of: capturing breath samples, controlling how the breath samples are generated and treated, and providing additional data regarding the patient and/or their current physiological state. FIG. 2 is a schematic view of a breath sampling mask 200 as worn by a patient 100 in accordance with various embodiments herein. The breath sampling mask 200 can include one or more elastic members 202, 204 configured to secure the breath sampling mask 200 to the patient's face. The pressure of the breath sampling mask 200 on the face can aid in forming an air tight connection of the breath sampling mask 200 to the patient's face.

[0055] In the embodiment of FIG. 2, when the patient creates a negative pressure inside the breath sampling mask 200, air can be drawn from the ambient environment into the breath sampling mask 200 through the exterior surface of breath sampling mask 200 (or a portion thereof), as indicated in FIG. 2 by air inflow arrows 210, 212, 214, and 216. As such, the breath sampling mask 200, or portions thereof, can be made of a porous material (one or more layers of material) to allow air to be drawn in, in this way. Porous materials can include, but are not limited to, woven and non-woven fibrous materials, porous cellulosic materials, porous polymers, porous or non-porous materials assuming porous structures such as grids, weaves, sieves, and the like. However, in other embodiments, the breath sampling mask 200, or portions thereof, can be made of a non-porous material. Non-porous materials can include, but are not limited to, polymers, metals, cellulosic materials, composites, metals, ceramics, and the like.

[0056] In some embodiments, breath sampling mask 200 can include filters or conditioned surfaces to treat the incoming air such that it can do one or more of: filtering particulate matter from the air, providing humidity control, providing a filter for organic or inorganic matter, and providing for adsorption of compounds and/or particulates in the ambient environment. By way of example, a carbon surface can be included on the exterior to filter out environmental particulates and/or environmental volatile organic compounds (VOCs). For example, a carbon material can be sprayed on, or otherwise applied to, an outer surface of the breath sampling mask 200. In some embodiments, the breath sampling mask 200 can include a carbon layer disposed within the mask itself. For example, a carbon material can be integrated into a material layer used to make the breath sampling mask 200 and/or sandwiched in between layers of material used to make the breath sampling mask 200. Carbon herein can be specifically be carbon that can absorb significant amounts of VOCs through high surface area such as activated carbon or activated charcoal (in some cases one gram of activated carbon has a surface area in excess of 3,000 m² or more) and/or through the use of chemical treatments to enhance absorption properties.

[0057] The breath sampling mask 200 can include various ports or conduits in and out of the breath sampling mask 200,

some of which may be in fluid communication with valves or other components or portions of the breath sampling mask 200. By way of example, the breath sampling mask 200 can include one or more conduits 206, which can serve as a passageway for breath samples, exhaust air, wires, or the like.

[0058] In the embodiment of FIG. 2, air is primarily drawn in through the mask housing material itself, however, in other embodiments an incoming port or conduit can be used through which air is drawn in. FIG. 3 is a schematic view of a breath sampling mask 200 as worn by a patient 100 in accordance with various embodiments herein. The breath sampling mask 200 can include one or more elastic members 202, 204 configured to secure the breath sampling mask 200 to the patient's face. The breath sampling mask 200 can include various ports or conduits in and out of the breath sampling mask 200, some of which may be in fluid communication with valves or other components or portions of the breath sampling mask 200. By way of example, in some embodiments, the breath sampling mask 200 can include an air intake port 308. When the patient creates a negative pressure inside the breath sampling mask 200, air can be drawn from the ambient environment into the breath sampling mask 200 through the air intake port 308, as indicated in FIG. 3 by air inflow arrows 210, 212, 214, and 216. The breath sampling mask 200 can also include one or more conduits 206, which can serve as a passageway for breath samples, exhaust air, wires, or the like.

[0059] It may be desirable to pre-condition and/or filter the inhaled air prior to its passage through the mask housing or port 308. In some embodiments, a preconditioning unit (not shown) can be connected to an air intake port 308 via a suitable connector, such as a bayonet connector. Pre-conditioning and/or filtering the inhaled air can include, but not be limited to, providing humidity control, providing temperature control, filtering particulate matter from the air, filtering organic or inorganic matter, including VOCs, by providing for adsorption and/or absorption of compounds and/or particulates from the ambient environment.

[0060] Referring now to FIG. 4, a schematic cutaway view of a breath sampling mask 200 as worn by a patient 100 is shown in accordance with various embodiments herein. The breath sampling mask 200 includes a mask housing 402 that is configured to cover a portion of the face of the patient 100. The mask housing 402 can define an interior chamber 406, which can be a breath receiving chamber. The breath sampling mask 200 can also include a nose clip member 404 connected to the mask housing 402 for helping to secure the breath sampling mask 200 to the patient 100. In some embodiments, the nose clip member 404 can work in collaboration with the elastic members 202, 204, to form an air tight connection of the breath sampling mask 200 against the patient's face. In some embodiments, breath sampling mask 200 can include a gas outflow conduit 206 in fluid communication with the breath receiving chamber.

[0061] The nose clip member 404 can take on various forms and be made of various materials. In some embodiments, the nose clip member 404 can include a U-shaped or V-shaped member which can exert at least some pressure on a patient's nose from two-directions that are at least partially opposed. In some embodiments, the nose clip member 404 can include a spring-like element which can expand under applied force to allow the nose clip member to fit over a patient's nose, but then exert pressure on the nose when the

applied force is released. Materials used to form the nose clip member 404 can include, but are not limited to, polymers, metals, composites, and the like.

[0062] In various embodiments, the breath sampling mask 200 can include a one-way airflow valve 408. The one-way airflow valve 408 can be in fluid communication between the air intake port 308 and the interior chamber 406, the one-way airflow valve 408 only allowing a flow of air from the area outside of the mask housing 402 into the interior chamber 406. In some embodiments, a filter can be placed in fluid communication with one-way airflow valve 408 such that it can remove particulate or chemical impurities from the environmental air prior to being inhaled by patient 100. In some embodiments, the filter can be integrated with the valve 408 structure. The filter can do one or more of filter out particulate matter from inspired air, provide humidity control, provide a filter for organic or inorganic matter, and/or provide for adsorption of compounds and/or particulates in the ambient environment. By way of example, the filter can include a carbon material, such as those described above, to filter out environmental particulates and/or environmental volatile organic compounds (VOCs).

[0063] In some embodiments, the breath sampling mask 200 can include a sensor 410 that can be connected to the nose clip member 404. In some embodiments, the sensor 410 can be configured to contact the skin of the patient 100 when the mask housing 402 is worn by the patient 100. The sensor 410 can be selected from a group including a temperature sensor, a heart rate sensor, and a blood pressure sensor.

[0064] It will be appreciated that while the sensor 410 in FIG. 4 is shown as being connected to the nose clip member 404 and in contact with the skin of the patient, other embodiments for the sensor 410 can be contemplated. For example, in some embodiments the sensor 410 can include an ear clip sensor, a fingertip sensor, a carotid artery sensor, or a galvanic skin sensor that is not integral with the mask, but connected to the mask housing via a wired or wireless connection. In some embodiments the sensor 410 can include non-contact sensors (e.g., that does not contact the skin), such as those used in electromagnetic-based, laser-based, and image-based sensor systems.

[0065] In some embodiments, the breath sampling mask 200 can also include additional sensors 412, 414, which can be on the outside of the breath sampling mask 200 or on the inside of the breath sampling mask 200. Exemplary sensors can include an ambient temperature sensor, an ambient humidity sensor, an internal temperature sensor, and an internal humidity sensor.

[0066] While the embodiment of FIG. 4 shows a single chamber inside the mask, it will be appreciated that other embodiments of masks herein can include multiple chambers that are isolated from one another. The mask can be configured to allow air and breath samples to move through the chambers of the mask in only a particular way or direction. FIG. 5 is a schematic cutaway view of a breath sampling mask 200 as worn by a patient in accordance with various embodiments herein. In this embodiment, the breath receiving chamber includes dividing wall 506 to isolate breath receiving chamber into a nasal chamber 502 and a mouth chamber 504, as defined by the mask housing 402. The nasal chamber 502 and the mouth chamber 504 can be separated from one another when the breath sampling mask 200 comes into contact with the face of patient during usage.

[0067] Separating the interior volume defined by the mask housing 402 into nasal chambers 502 and mouth chambers 504, in combination with valves, can allow for a controlled unidirectional flow of air through the breath sampling mask 200. In particular, the one-way airflow valve 408 only allows a flow of air from the area outside of the mask housing 402 into the nasal chamber 502 through air intake port 308. Further another one-way airflow valve 508 only allows a flow of air from the mouth chamber 504 out through conduit 206. In this manner, air only moves through the chambers of the breath sampling mask 200 in one direction. It will be appreciated that while air intake port 308 and one-way airflow valve 408 are shown disposed in the mask housing 402 within the nasal chamber 502, the air intake port 308 and one-way airflow valve 408 can alternatively be disposed in the mask housing 402 within the mouth chamber 504. In some embodiments, the air intake port 308 and one-way airflow valve 408 can be disposed in the mask housing 402 in both the nasal chamber 502 and within the mouth chamber 504. In some embodiments, breath sampling mask 200 can include a gas outflow conduit 206 in fluid communication with the nasal chamber 502, the mouth chamber 504, or both.

[0068] In some embodiments, it may be desirable to retain a breath sample within the breath sampling mask 200 itself or another associated structure. For example, a container can be used to hold a breath sample, and the container itself can be disposed in the breath sampling mask 200 or otherwise in fluid communication with the breath sampling mask 200. Referring now to FIG. 6, a schematic cutaway view of a breath sampling mask 200 as worn by a patient 100 is shown in accordance with various embodiments herein. In this view, a breath sample container 602 is disposed within the mouth chamber 504. The breath sample container 602 can define an interior volume 604 in order to hold and retain a breath sample. It will be appreciated that while the breath sample container 602 shown in FIG. 6 is removable, in another embodiment, breath sample container 602 could be an integral part of the breath sampling mask 200.

[0069] Breath sampling masks in accordance with embodiments herein can form parts of breath sampling systems. Such breath sampling systems can include a breath sampling mask along with other components such as chemical sensors including sensing elements and circuitry for generating signals based on electrical properties of the sensing elements. Referring now to FIG. 7, a schematic view is shown of a breath sampling system 700 in accordance with various embodiments herein. The breath sampling system 700 can include breath sampling mask 200, which can be worn by a patient 100. In the embodiment shown in FIG. 7, air can be inspired into a nasal chamber 502 and into the lungs of the patient 100. This air can then be expired out into a mouth chamber 504 before passing out through conduit 206 and on to a gaseous analyte sensing device 702 for analysis.

[0070] The gaseous analyte sensing device 702 can include a housing 718. The gaseous analyte sensing device 702 can be connected to breath sampling mask 200 via conduit 206, through which a patient's gaseous breath sample can travel to be evaluated at gaseous analyte sensing device 702. The patient's gaseous breath sample can pass through an evaluation sample (patient sample) input port 704. The gaseous analyte sensing device 702 can also include a control sample (environment) input port 706. The

gaseous analyte sensing device 702 can also include a chemical sensor element chamber 708, into which a chemical sensor element can be placed. The gaseous analyte sensing device 702 can also include a display screen 710 and a user input device 712, such as a keyboard. The gaseous analyte sensing device 702 can also include a gas outflow port 714. The gaseous analyte sensing device 702 can also include flow sensors in fluid communication with the gas flow associated with one or more of the evaluation sample input port 704 and control sample input port 706. It will be appreciated that many different types of flow sensors can be used. In some embodiments, a hot-wire anemometer can be used to measure the flow of air. In some embodiments, the gaseous analyte sensing device 702 can include a CO₂ sensor in fluid communication with the gas flow associated with one or more of the evaluation sample input port 704 and control sample input port 706.

[0071] In various embodiments, the gaseous analyte sensing device 702 can also include other functional components. By way of example, the gaseous analyte sensing device 702 can include a humidity control module 716 and/or a temperature control module 720. The humidity control module 716 can be in fluid communication with the gas flow associated with one or more of the evaluation sample input port 704 and control sample input port 706 in order to adjust the humidity of one or both gas flow streams in order to make the relative humidity of the two streams substantially the same in order to prevent an adverse impact on the readings obtained by the system. The temperature control module 720 can be in fluid communication with the gas flow associated with one or more of the evaluation sample input port 704 and control sample input port 706 in order to adjust the temperature of one or both gas flow streams in order to make the temperature of the two streams substantially the same in order to prevent an adverse impact on the readings obtained by the system. By way of example, the air flowing into the control sample input port can be brought up to 37 degrees Celsius in order to match the temperature of air coming from a patient. The humidity control module and the temperature control module can be upstream from the input ports, within the input ports, or downstream from the input ports in the housing 718 of the gaseous analyte sensing device 702. In some embodiments, the humidity control module 716 and the temperature control module 720 can be integrated.

[0072] In some embodiments, breath samples can be put into contact with a chemical sensor element in the mask itself or in a structure directly attached to the mask. One or more components of the gaseous analyte sensing device 702 shown in reference to FIG. 7 can be integrated into the breath sampling mask 200. As such, in some embodiments, a separate gaseous analyte sensing device may not be needed in a breath sensing system. Referring now to FIG. 8, a schematic view is shown of a breath sampling system 800 in accordance with various embodiments herein. The breath sampling system 800 can include a breath sampling mask 200 including a nasal chamber 502 and a mouth chamber 504. A chemical sensor holder 802 can be disposed within a breath receiving chamber, such as mouth chamber 504. The chemical sensor holder 802 can be configured to allow removable mounting of a chemical sensor element. The chemical sensor element can interface with a breath sample collected through the breath sampling mask 200 when the patient 100 exhales into the breath sampling mask 200.

Exemplary chemical sensor elements will be described more fully below in reference to FIGS. 18-21.

[0073] Sample gas (breath) can optionally pass through a structure 806 such as a filter or valve and into the chemical sensor holder 802. After entering the chemical sensor holder 802, the gas can then pass out of the system through an exhaust port 804. Measurement circuitry (not shown in this view) can be associated with the chemical sensor holder 802 in order to generate a signal based on an electrical property of the chemical sensor element. The signal(s) can be conveyed to an analysis device 810 through a data conduit 808. It will be appreciated, however, that signals can also be conveyed wirelessly. Referring now to FIG. 9, a schematic view is shown of a breath sampling system 900 in accordance with various embodiments herein. In this embodiment, the breath sampling system 900 includes communication circuitry and an antenna 902 in order to generate wireless signals that can be received by an analysis device 810.

[0074] In some embodiments, the chemical sensor holder 802 can be housed in a separate structure that can be attached (removably or not) to the breath sampling mask 200. Referring now to FIG. 10, a schematic view is shown of a breath sampling system 1000 in accordance with various embodiments herein. In this embodiment, a chemical sensor holder housing 1002 is included. The chemical sensor holder housing can be in fluid communication with the breath receiving chamber. Sample gas can pass from the mouth chamber 504 into chemical sensor holder housing 1002 and, specifically, into the chemical sensor holder 802 located within the chemical sensor holder housing 1002. Sample gas can pass over chemical sensor element (not shown), secured by chemical sensor holder 802, and out exhaust port 804.

[0075] It will be appreciated that mask herein can take on many different specific forms. Referring now to FIG. 11, a schematic view is shown of a breath sampling system 1100 in accordance with various embodiments herein. The breath sampling system 1100 can include breath sampling mask 200, which can be worn by a patient 100. Breath sampling mask 200 can include nose clip member 404 for helping to secure the breath sampling mask 200 to the patient 100. In the embodiment shown in FIG. 11, air can be inspired into the mask and into the lungs of the patient 100. This air can then be expired out into a mouth chamber before passing out through conduit 206 and on to a gaseous analyte sensing device 702. In some embodiments, the breath sampling mask 200 and gaseous analyte sensing device 702 can be connected directly via a data conduit, such as data conduit 808 shown in FIG. 8. In other embodiments, the breath sampling mask 200 and gaseous analyte sensing device 702 can be connected wirelessly.

[0076] The embodiment of breath sampling mask 200 shown in FIG. 11 will be described in more detail in reference to FIGS. 12-17. Referring now to FIG. 12, a schematic side view of an exterior of breath sampling mask 200 is shown. Breath sampling mask 200 can include air intake port 308 that can be in fluid communication with a one-way airflow valve on the interior (not shown) of the breath sampling mask 200. The breath sampling mask 200 can include one or more elastic members 202 and 204 configured to secure the breath sampling mask 200 to the patient's face. The breath sampling mask 200 can include various ports or conduits in and out of the breath sampling

mask **200**, some of which may be in fluid communication with valves, filters, or other components or portions of the breath sampling mask **200**. By way of example, the breath sampling mask **200** can include one or more conduits **206**, which can serve as a passageway for breath samples, exhaust air, wires, or the like. Like structures of breath sampling mask **200** are shown in a schematic isometric view in FIG. **13** and in a schematic top plan view in FIG. **14**.

[0077] Referring now to FIG. **15**, a schematic cross-sectional view of a side of the breath sampling mask **200** is shown. Breath sampling mask **200** can include nose clip member **404** attached to mask housing **402**. In some embodiments, one or more sensors **410** can be connected to the nose clip member **404**, the one or more sensors **410** configured to contact the skin of the patient **100** when the breath sampling mask **200** is worn by the patient **100**. The sensor **410** can be selected from a group including a temperature sensor, a heart rate sensor, and a blood pressure sensor.

[0078] Breath sampling mask **200** can also include a nasal chamber **502** and a mouth chamber **504**. Nasal chamber **502** and mouth chamber **504** can be separated by a dividing wall **506**. It will be appreciated that in some embodiments the nasal chamber **502** defines the breath receiving chamber, while in other embodiments the mouth chamber can define the breath receiving chamber. In some embodiments, both the nasal chamber **502** and the mouth chamber can define the breath receiving chamber. In some embodiments, breath sampling mask **200** does not have a dividing wall **506**. Mouth chamber **504** can include a dividing member **1502** that can span at least a portion of mouth chamber **504** without completely dividing mouth chamber **504** into more than one section. Attached to dividing member **1502** can be a chemical sensor holder **802**. Chemical sensor holder **802** can serve as an anchor point to secure a chemical sensor element (not shown) within the interior, or patient-facing side, of breath sampling mask **200**.

[0079] Like structures of breath sampling mask **200** are shown in a schematic isometric view in FIG. **16** and in a schematic bottom plan view in FIG. **17**. FIG. **17** further shows that breath sampling mask **200** can include a one-way airflow valve **408** that can be in fluid communication with a one-way airflow valve on the exterior (not shown) of the breath sampling mask **200**.

[0080] Referring now to FIG. **18**, a schematic top plan view of a chemical sensor element **1800** is shown in accordance with various embodiments herein. The chemical sensor element **1800** can include a substrate **1802**. It will be appreciated that the substrate can be formed from many different materials. By way of example, the substrate can be formed from polymers, metals, glasses, ceramics, cellulose materials, composites, metal oxides, and the like. The thickness of the substrate can vary. In some embodiments, the substrate has sufficient structural integrity to be handled without undue flexure that could damage components thereon. In some embodiments, the substrate can have a thickness of about 0.05 mm to about 5 mm. The length and width of the substrate can also vary. In some embodiments, the length (or major axis) can be from about 0.2 cm to about 10 cm. In some embodiments, the width (perpendicular to the major axis) can be from about 0.2 cm to about 8 cm. In some embodiments, the chemical sensor element can be disposable. In some embodiments, the chemical sensor element can be reusable.

[0081] The chemical sensor element can include a first measurement zone **1804** disposed on the substrate **1802**. In some embodiments, the first measurement zone **1804** can define a portion of a first gas flow path. The first measurement zone (or breath sample zone) **1804** can include a plurality of discrete binding detectors that can sense analytes in a gaseous sample, such as a breath sample. A second measurement zone (or environment sample zone) **1806**, separate from the first measurement zone **1804**, can also be disposed on the substrate **1802**. The second measurement zone **1806** can also include a plurality of discrete binding detectors. In some embodiments, the second measurement zone **1806** can include the same (in type and/or number) discrete binding detectors that are within the first measurement zone **1804**. In some embodiments, the second measurement zone **1806** can include only a subset of the discrete binding detectors that are within the first measurement zone **1804**. In operation, the data gathered from the first measurement zone, which can be reflective of the gaseous sample analyzed, can be corrected or normalized based on the data gathered from the second measurement zone, which can be reflective of analytes present in the environment. However, in some embodiments, both a first and second measurement zone can reflect the breath sample analyzed. In some embodiments, a second measurement zone is not included.

[0082] In some embodiments, a third measurement zone (drift control or witness zone) **1808** can also be disposed on the substrate. The third measurement zone **1808** can include a plurality of discrete binding detectors. In some embodiments, the third measurement zone **1808** can include the same (in type and/or number) discrete binding detectors that are within the first measurement zone **1804**. In some embodiments, the third measurement zone **1808** can include only a subset of the discrete binding detectors that are within the first measurement zone **1804**. In some embodiments, the third measurement zone **1808** can include discrete binding detectors that are different than those of the first measurement zone **1804** and the second measurement zone **1806**. In some embodiments, a third measurement zone **1808** is not included. Aspects of the third measurement zone are described in greater detail below.

[0083] The first measurement zone, the second measurement zone, and the third measurement zone can be the same size or can be of different sizes. In some embodiments, the chemical sensor element **1800** can also include a component **1810** to store reference data. The component **1810** to store reference data can be an electronic data storage device, an optical data storage device, a printed data storage device (such as a printed code), or the like. The reference data can include, but is not limited to, data regarding the third measurement zone.

[0084] In some embodiments, chemical sensor elements embodied herein can include electrical contacts (not shown) that can be used to provide power to components on the chemical sensor element **1800** and/or can be used to read data regarding the measurement zones and/or data from the stored in component **1810**. However, in other embodiments there are no external electrical contacts on the chemical sensor element **1800**.

[0085] Chemical sensor element **1800** can be configured to fit within chemical sensor holder **802**, shown in FIGS. **8-10** and **15-17**. Further aspects of exemplary chemical sensor

elements can be found in U.S. application Ser. No. 14/883, 895, the content of which is herein incorporated by reference in its entirety.

[0086] Many different types of circuits can be used to gather data from chemical sensor elements. It will be appreciated that the chemical sensor elements embodied herein can include those that are compatible with passive wireless sensing techniques. One example of a passive sensor circuit **2202** and a portion of a reading circuit **2222** is illustrated schematically in FIG. **22** and discussed in more detail below, however, many other circuits are contemplated herein.

[0087] Referring now to FIG. **19**, a schematic diagram of a portion of a measurement zone **1900** is shown in accordance with various embodiments herein. A plurality of discrete binding detectors **1902** can be disposed within the measurement zone **1900** in an array. In some embodiments, a chemical sensor element can include a plurality of discrete binding detectors configured in an array within a measurement zone. In some embodiments, the plurality of discrete binding detectors can be identical, while in other embodiments the plurality of discrete binding detectors can be different from one another.

[0088] In some embodiments, the discrete binding detectors can be heterogeneous in that they are all different from one another in terms of their binding behavior or specificity with regard a particular analyte. In some embodiments, some discrete binding detectors can be duplicated for validation purposes, but are otherwise heterogeneous from other discrete binding detectors. Yet in other embodiments, the discrete binding detectors can be homogeneous. While the discrete binding detectors **1902** of FIG. **19** are shown as boxes organized into a grid, it will be appreciated that the discrete binding detectors can take on many different shapes (including, but not limited to, various polygons, circles, ovals, irregular shapes, and the like) and, in turn, the groups of discrete binding detectors can be arranged into many different patterns (including, but not limited to, star patterns, zig-zag patterns, radial patterns, symbolic patterns, and the like).

[0089] In some embodiments, the order of specific discrete binding detectors **1902** across the length **1912** and width **1914** of the measurement zone can be substantially random. In other embodiments, the order can be specific. For example, in some embodiments, a measurement zone can be ordered so that the specific discrete binding detectors **1902** for analytes having a lower molecular weight are located farther away from the incoming gas flow relative to specific discrete binding detectors **1902** for analytes having a higher molecular weight which are located closer to the incoming gas flow. As such, chromatographic effects which may serve to provide separation between chemical compounds of different molecular weight can be taken advantage of to provide for optimal binding of chemical compounds to corresponding discrete binding detectors.

[0090] The number of discrete binding detectors within a particular measurement zone can be from about 1 to about 100,000. In some embodiments, the number of discrete binding detectors can be from about 1 to about 10,000. In some embodiments, the number of discrete binding detectors can be from about 1 to about 1,000. In some embodiments, the number of discrete binding detectors can be from about 2 to about 500. In some embodiments, the number of discrete binding detectors can be from about 10 to about 500. In some embodiments, the number of discrete binding

detectors can be from about 50 to about 500. In some embodiments, the number of discrete binding detectors can be from about 1 to about 250. In some embodiments, the number of discrete binding detectors can be from about 1 to about 50.

[0091] Each of the discrete binding detectors suitable for use herein can include at least a portion of one or more electrical circuits. By way of example, in some embodiments, each of the discrete binding detectors can include one or more passive electrical circuits. In some embodiments, the graphene varactors can be included such that they are integrated directly on an electronic circuit. In some embodiments, the graphene varactors can be included such that they are wafer bonded to the circuit. In some embodiments, the graphene varactors can include integrated readout electronics, such as a readout integrated circuit (ROIC). The electrical properties of the electrical circuit, including resistance or capacitance, can change upon binding, such as specific and/or non-specific binding, with a component from a breath sample.

[0092] In some embodiments, the discrete binding detectors embodied herein can include graphene-based variable capacitors (or graphene varactors). Referring now to FIG. **20**, a schematic view of a graphene varactor **2000** is shown in accordance with the embodiments herein. It will be appreciated that graphene varactors can be prepared in various ways with various geometries, and that the graphene varactor shown in FIG. **20** is just one example in accordance with the embodiments herein.

[0093] Graphene varactor **2000** can include an insulator layer **2002**, a gate electrode **2004** (or “gate contact”), a dielectric layer (not shown in FIG. **20**), one or more graphene layers, such as graphene layers **2008a** and **2008b**, and a contact electrode **2010** (or “graphene contact”). In some embodiments, the graphene layer(s) **2008a-b** can be contiguous, while in other embodiments the graphene layer(s) **2008a-b** can be non-contiguous. Gate electrode **2004** can be deposited within one or more depressions formed in insulator layer **2002**. Insulator layer **2002** can be formed from an insulative material such as silicon dioxide, formed on a silicon substrate (wafer), and the like. Gate electrode **2004** can be formed by an electrically conductive material such as chromium, copper, gold, silver, tungsten, aluminum, titanium, palladium, platinum, iridium, and any combinations or alloys thereof, which can be deposited on top of or embedded within the insulator layer **2002**. The dielectric layer can be disposed on a surface of the insulator layer **2002** and the gate electrode **2004**. The graphene layer(s) **2008a-b** can be disposed on the dielectric layer. The dielectric layer will be discussed in more detail below in reference to FIG. **21**.

[0094] Graphene varactor **2000** includes eight gate electrode fingers **2006a-2006h**. It will be appreciated that while graphene varactor **2000** shows eight gate electrode fingers **2006a-2006h**, any number of gate electrode finger configurations can be contemplated. In some embodiments, an individual graphene varactor can include fewer than eight gate electrode fingers. In some embodiments, an individual graphene varactor can include more than eight gate electrode fingers. In other embodiments, an individual graphene varactor can include two gate electrode fingers. In some embodiments, an individual graphene varactor can include 1, 2, 3, 4, 5, 6, 7, 8, 9, 10, or more gate electrode fingers.

[0095] Graphene varactor **2000** can include one or more contact electrodes **2010** disposed on portions of the graphene layers **2008a** and **2008b**. Contact electrode **2010** can be formed from an electrically conductive material such as chromium, copper, gold, silver, tungsten, aluminum, titanium, palladium, platinum, iridium, and any combinations or alloys thereof. Further aspects of exemplary graphene varactors can be found in U.S. Pat. No. 9,513,244, the content of which is herein incorporated by reference in its entirety.

[0096] Referring now to FIG. **21**, a schematic cross-sectional view of a portion of a graphene varactor **2100** is shown in accordance with various embodiments herein. The graphene varactor **2100** can include an insulator layer **2002** and a gate electrode **2004** recessed into the insulator layer **2002**. The gate electrode **2004** can be formed by depositing an electrically conductive material in the depression in the insulator layer **2002**, as discussed above in reference to FIG. **20**. A dielectric layer **2102** can be formed on a surface of the insulator layer **2002** and the gate electrode **2004**. In some examples, the dielectric layer **2102** can be formed of a material, such as, silicon dioxide, aluminum oxide, hafnium dioxide, zirconium dioxide, hafnium silicate, or zirconium silicate.

[0097] The graphene varactor **2100** can include a single graphene layer **2104** that can be disposed on a surface of the dielectric layer **2102**. The graphene layer **2104** can be surface-modified with a modification layer **2106**. It will be appreciated that in some embodiments, the graphene layer **2104** is not surface-modified.

[0098] The breath sensing systems described herein can include circuitry for generating signals from the discrete binding detectors. Such circuitry can include active and passive sensing circuits. Such circuitry can implement wired (direct electrical contact) or wireless sensing techniques. Referring now to FIG. **22**, a schematic diagram of a passive sensor circuit **2202** and a portion of a reading circuit **2222** is shown in accordance with various aspects herein. In some embodiments, the passive sensor circuit **2202** can include a metal-oxide-graphene varactor **2204** (wherein RS represents the series resistance and CG represents the varactor capacitor) coupled to an inductor **2210**. In some embodiments, the reading circuit **2222** can include a reading coil having a resistance **2224** and an inductance **2226**. However, it will be appreciated that the circuits shown in FIG. **22** are merely one approach. Many different approaches are contemplated herein.

[0099] In some embodiments, a method of determining the presence of one or more disease states in a patient is included. The method can include putting a breath sampling mask on a patient and alerting the patient to breathe in and out to generate a breath sample. The method can include contacting the breath sample with a chemical sensor element. The method can further include collecting data from chemical sensor element comprising a plurality of discrete binding detectors. The method can further include using a measurement circuit to generate signals from the discrete binding detectors. The method can further include evaluating the signals by comparing them to previously obtained sets of signals or signal patterns.

[0100] In some embodiments, the method can include alerting the patient to breathe in through the nose and out through the mouth to generate a breath sample. In some embodiments, the method can include instructing the patient

to breathe in through the mouth and out through the mouth. In some embodiments, the method can include instructing the patient to breathe in through the mouth and out through the nose. In yet other embodiments, the method can include instructing the patient to breathe in through the nose and out through the nose.

[0101] In some embodiments, the method can include evaluating the signals by comparing them to previously obtained sets of signals or patterns for patients in a non-diseased or diseased state. In some embodiments, the diseased state can include, but not be limited to cancer, including lung cancer, blood-borne cancers, prostate cancer, rectal cancer, breast cancer, liver cancer, pancreatic cancer, chronic obstructive pulmonary disease, diabetes, heart failure, and the like. In some embodiments, the comparison can include detecting patterns of differentiation between non-diseased and diseased states. In some embodiments, the method can include detecting one or more volatile organic compounds in the breath of a patient.

[0102] It should be noted that, as used in this specification and the appended claims, the singular forms “a,” “an,” and “the” include plural referents unless the content clearly dictates otherwise. Thus, for example, reference to a composition containing “a compound” includes a mixture of two or more compounds. It should also be noted that the term “or” is generally employed in its sense including “and/or” unless the content clearly dictates otherwise.

[0103] It should also be noted that, as used in this specification and the appended claims, the phrase “configured” describes a system, apparatus, or other structure that is constructed or configured to perform a particular task or adopt a particular configuration to. The phrase “configured” can be used interchangeably with other similar phrases such as arranged and configured, constructed and arranged, constructed, manufactured and arranged, and the like.

[0104] All publications and patent applications in this specification are indicative of the level of ordinary skill in the art to which this technology pertains. All publications and patent applications are herein incorporated by reference to the same extent as if each individual publication or patent application was specifically and individually indicated by reference. The publications and patents disclosed herein are provided solely for their disclosure. Nothing herein is to be construed as an admission that the inventors are not entitled to antedate any publication and/or patent, including any publication and/or patent cited herein.

[0105] The technology has been described with reference to various specific and preferred embodiments and techniques. However, it should be understood that many variations and modifications may be made while remaining within the spirit and scope of the technology. As such, the embodiments of the present technology described herein are not intended to be exhaustive or to limit the technology to the precise forms disclosed in the following detailed description. Rather, the embodiments are chosen and described so that others skilled in the art can appreciate and understand the principles and practices of the present technology.

1. A breath sensing system comprising:
 - a breath sampling mask comprising
 - a mask housing configured to cover a portion of the face of a patient, the mask housing defining a breath receiving chamber;
 - a chemical sensor element in fluid communication with the breath sampling mask, the chemical sensor element

comprising a plurality of discrete binding detectors, wherein the chemical sensor element interfaces with a breath sample collected through the breath sampling mask.

2. The breath sensing system of claim 1, further comprising circuitry for generating signals from the discrete binding detectors.

3. The breath sensing system of claim 1, a breath sampling mask further comprising a nose clip for helping to secure the breath sampling mask to the face of a patient.

4. The breath sensing system of claim 1, further comprising a sensor comprising one or more of a temperature sensor, a heart rate sensor, and a blood pressure sensor.

5. The breath sensing system of claim 1, further comprising a sensor comprising one or more of an ambient temperature sensor, an ambient humidity sensor, an internal temperature sensor, and an internal humidity sensor.

6. The breath sensing system of claim 1, further comprising a removable breath sample container disposed within the mouth chamber.

7. The breath sensing system of claim 1, further comprising a gas outflow conduit in fluid communication with the breath receiving chamber.

8. The breath sensing system of claim 1, further comprising a chemical sensor holder configured to allow removable mounting of a chemical sensor element.

9. The breath sensing system of claim 8, wherein the chemical sensor holder is disposed within the breath receiving chamber.

10. The breath sensing system of claim 1, further comprising a chemical sensor holder housing in fluid communication with the breath receiving chamber; wherein the chemical sensor element is disposed within the chemical sensor holder housing.

11. The breath sensing system of claim 1, further comprising a filter in fluid communication with the one-way airflow valve.

12. A breath sampling mask comprising:
a mask housing configured to cover a portion of the face of a patient, the mask housing defining a chamber;

the mask configured to remove volatile organic compounds from air drawn in through the mask housing.

13. The breath sampling mask of claim 12, further comprising a sensor comprising one or more of a temperature sensor, a heart rate sensor, and a blood pressure sensor.

14. The breath sampling mask of claim 12, further comprising a nose clip member for helping to secure the breath sampling mask to the patient.

15. The breath sampling mask of claim 14, further comprising a sensor attached to the nose clip member.

16. The breath sampling mask of claim 12, the mask housing further comprising a dividing wall isolating the chamber into a nasal chamber and a mouth chamber.

17. The breath sampling mask of claim 16, further comprising a one-way airflow valve in fluid communication with the nasal chamber and an area outside of the mask housing, the one-way airflow valve only allowing a flow of air from the area outside of the mask housing into the nasal chamber.

18. The breath sampling mask of claim 16, further comprising a chemical sensor holder configured to allow removable mounting of a chemical sensor element, wherein the chemical sensor holder is disposed within the mouth chamber.

19. The breath sampling mask of claim 12, further comprising a sensor comprising one or more of an ambient temperature sensor, an ambient humidity sensor, an internal temperature sensor, and an internal humidity sensor.

20. A method of determining the presence of one or more disease states of a patient comprising:

- putting a breath sampling mask on a patient;
- alerting the patient to breathe in and out to generate a breath sample;
- contacting the breath sample with a chemical sensor element, the chemical sensor element comprising a plurality of discrete binding detectors;
- using a measurement circuit to generate signals from the discrete binding detectors; and
- evaluating the signals by comparing them to previously obtained sets of signals or signal patterns.

* * * * *

| | | | |
|----------------|---|---------|------------|
| 专利名称(译) | 呼吸采样掩模和系统 | | |
| 公开(公告)号 | US20190254538A1 | 公开(公告)日 | 2019-08-22 |
| 申请号 | US16/280644 | 申请日 | 2019-02-20 |
| [标]申请(专利权)人(译) | 明尼苏达大学 波士顿科学西美德公司 | | |
| 申请(专利权)人(译) | 明尼苏达大学校董会 BOSTON SCIENTIFIC SCIMED , INC. | | |
| 当前申请(专利权)人(译) | 明尼苏达大学校董会 BOSTON SCIENTIFIC SCIMED , INC. | | |
| [标]发明人 | ERDMAN ARTHUR GUY SHERWOOD GREGORY J NELSON JUSTIN THEODORE | | |
| 发明人 | ERDMAN, ARTHUR GUY SHERWOOD, GREGORY J. PETERSON, GREGORY KERMIT NELSON, JUSTIN THEODORE FREKING, MICHAEL MATHIAS | | |
| IPC分类号 | A61B5/0205 A61B5/00 | | |
| CPC分类号 | A61B5/02055 A61B5/6803 A61B5/02438 A61B5/021 A61B2560/0242 A61B5/082 A61B5/097 | | |
| 优先权 | 62/632552 2018-02-20 US | | |
| 外部链接 | Espacenet USPTO | | |

摘要(译)

本文的实施例包括呼吸采样掩模，系统和相关方法。在一个实施例中，包括呼吸感测系统。呼吸感测系统可包括呼吸采样掩模。呼吸采样掩模可包括掩模壳体，该掩模壳体构造成覆盖患者面部的一部分。面罩壳体可以限定呼吸接收室。呼吸采样掩模可包括与呼吸采样掩模流体连通的化学传感器元件，其中化学传感器元件可包括多个离散的结合检测器。化学传感器元件可以与通过呼吸采样掩模收集的呼吸样本接合。本文还包括其他实施方案。

