



US 20190143129A1

(19) **United States**

(12) **Patent Application Publication**

**Meredith et al.**

(10) **Pub. No.: US 2019/0143129 A1**

(43) **Pub. Date: May 16, 2019**

(54) **MOBILE APPLICATIONS AND METHODS FOR CONVEYING PERFORMANCE INFORMATION OF A CARDIAC PACEMAKER**

*G16H 40/40* (2006.01)

*A61B 5/0205* (2006.01)

*A61N 1/37* (2006.01)

(71) Applicant: **AT&T Mobility II LLC**, Atlanta, GA (US)

(72) Inventors: **Sheldon Kent Meredith**, Roswell, GA (US); **Brandon B. Hilliard**, Woodstock, GA (US); **Mario Kosseifi**, Roswell, GA (US)

(73) Assignee: **AT&T Mobility II LLC**, Atlanta, GA (US)

(21) Appl. No.: **16/245,610**

(22) Filed: **Jan. 11, 2019**

**Related U.S. Application Data**

(60) Division of application No. 14/871,045, filed on Sep. 30, 2015, now Pat. No. 10,213,609, which is a continuation of application No. 13/191,996, filed on Jul. 27, 2011, now Pat. No. 9,158,890.

**Publication Classification**

(51) **Int. Cl.**

*A61N 1/372* (2006.01)

*A61B 5/00* (2006.01)

(52) **U.S. Cl.**

CPC ..... *A61N 1/37282* (2013.01); *A61B 5/0028*

(2013.01); *A61B 5/0031* (2013.01); *G16H*

*40/40* (2018.01); *A61B 5/02438* (2013.01);

*A61N 1/3706* (2013.01); *A61N 1/3702*

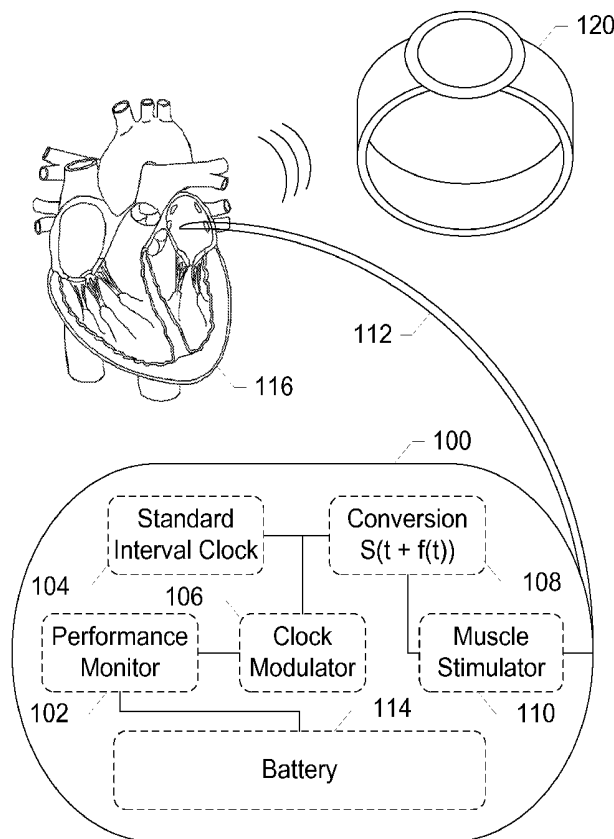
(2013.01); *A61N 1/3727* (2013.01); *A61B*

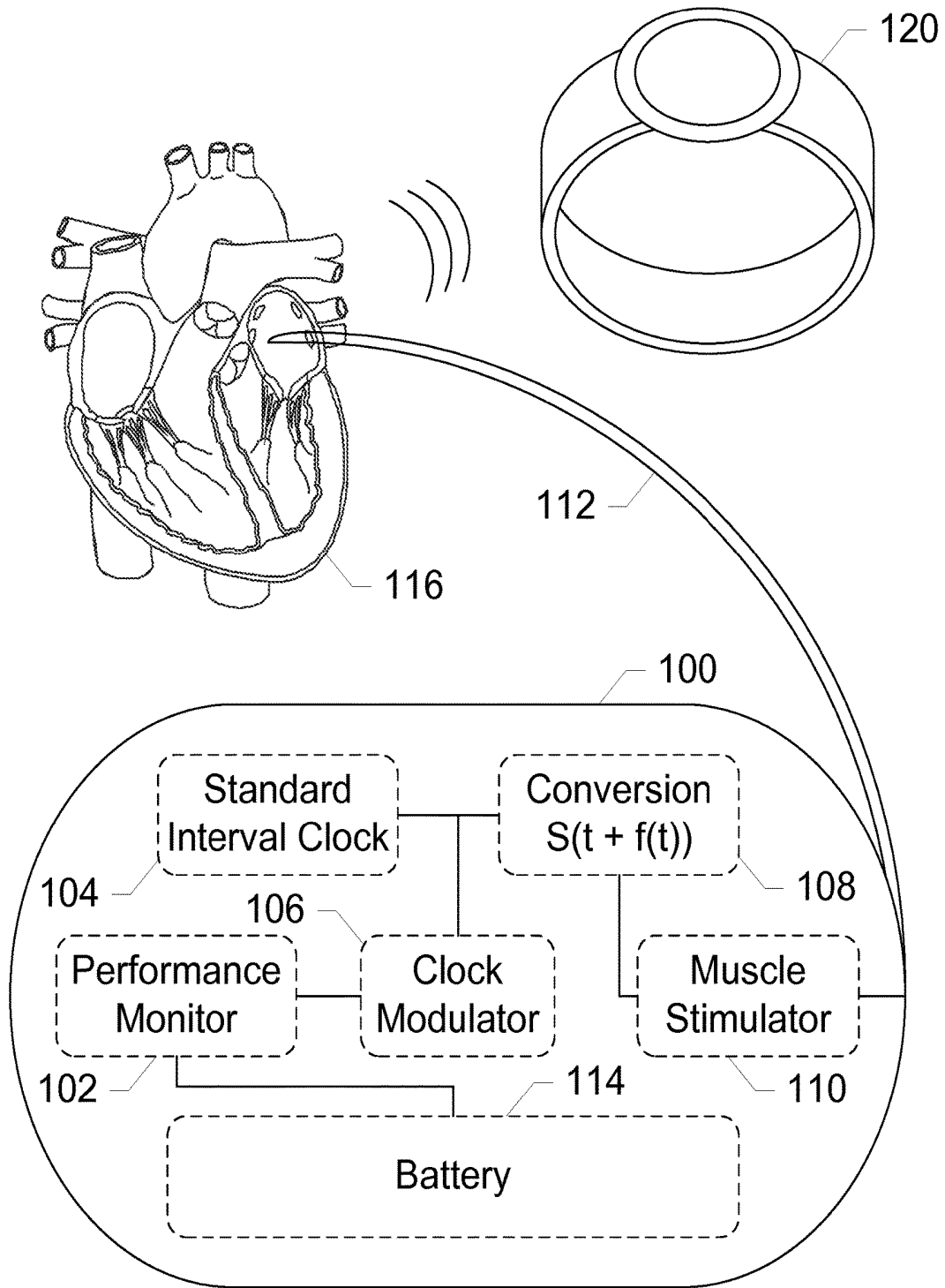
*5/0205* (2013.01)

(57)

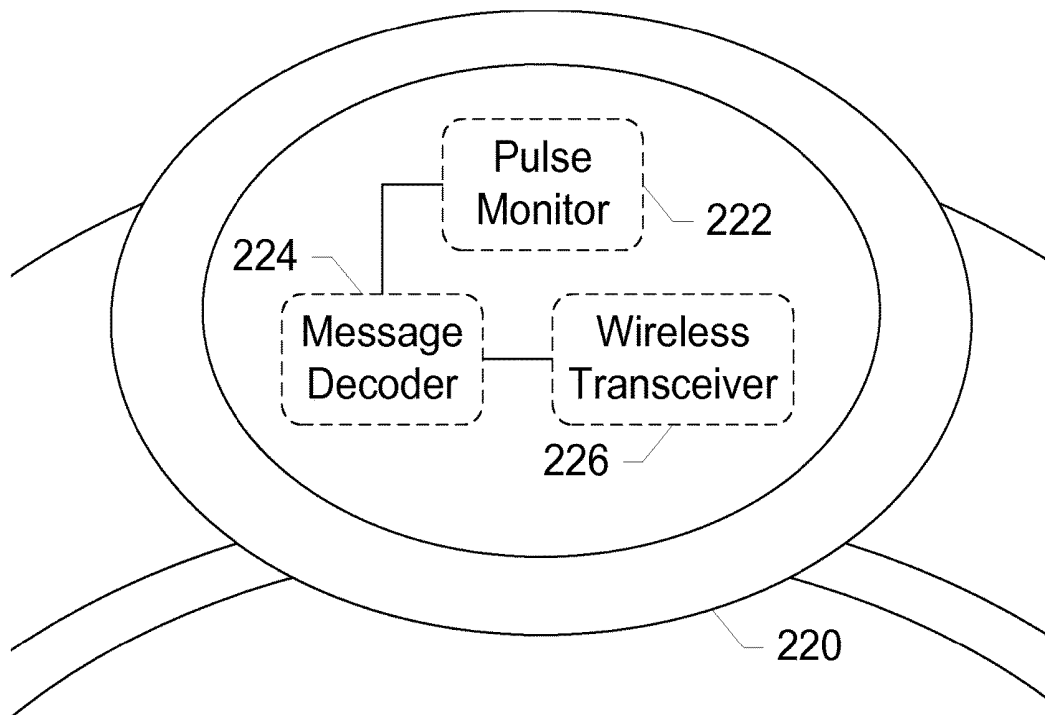
**ABSTRACT**

Devices, systems, and methods are disclosed for relaying information from a cardiac pacemaker to an external device. Logic on the pacemaker modulates a heartbeat clock of the pacemaker to encode information onto a blood pressure sequence by adding or subtracting a small subinterval to or from a pulse repetition interval of the pacemaker. A muscle stimulator beats the heart according to the modulated sequence. A monitoring device external to the body monitors the blood pressure to retrieve the encoded information, or message. The encoded information is then decoded to determine the information in the message. This information may concern the pacemaker as well as other devices within the body that communicate with the pacemaker such as blood monitors, etc. Since the message is conveyed via simple modulation of the heart beat intervals, no separate transmitter is required in the pacemaker which would otherwise increase cost and decrease battery life.

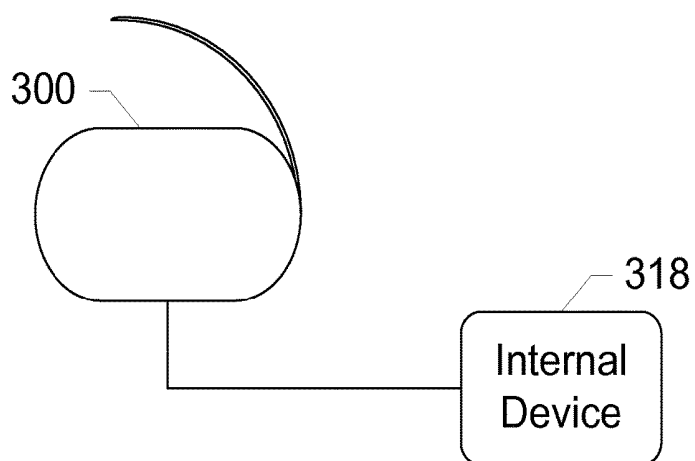




**FIG. 1**



**FIG. 2**



**FIG. 3**

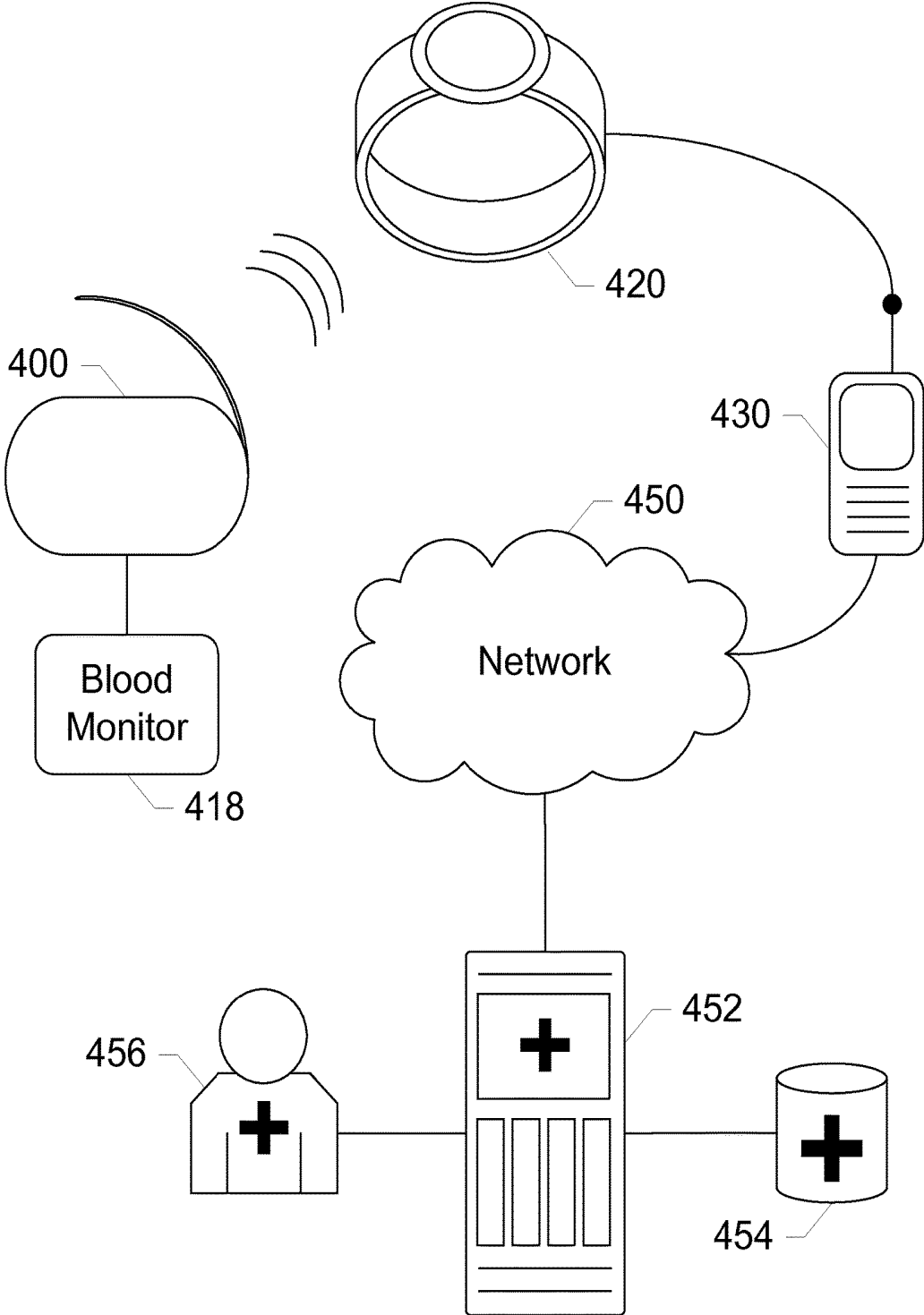


FIG. 4

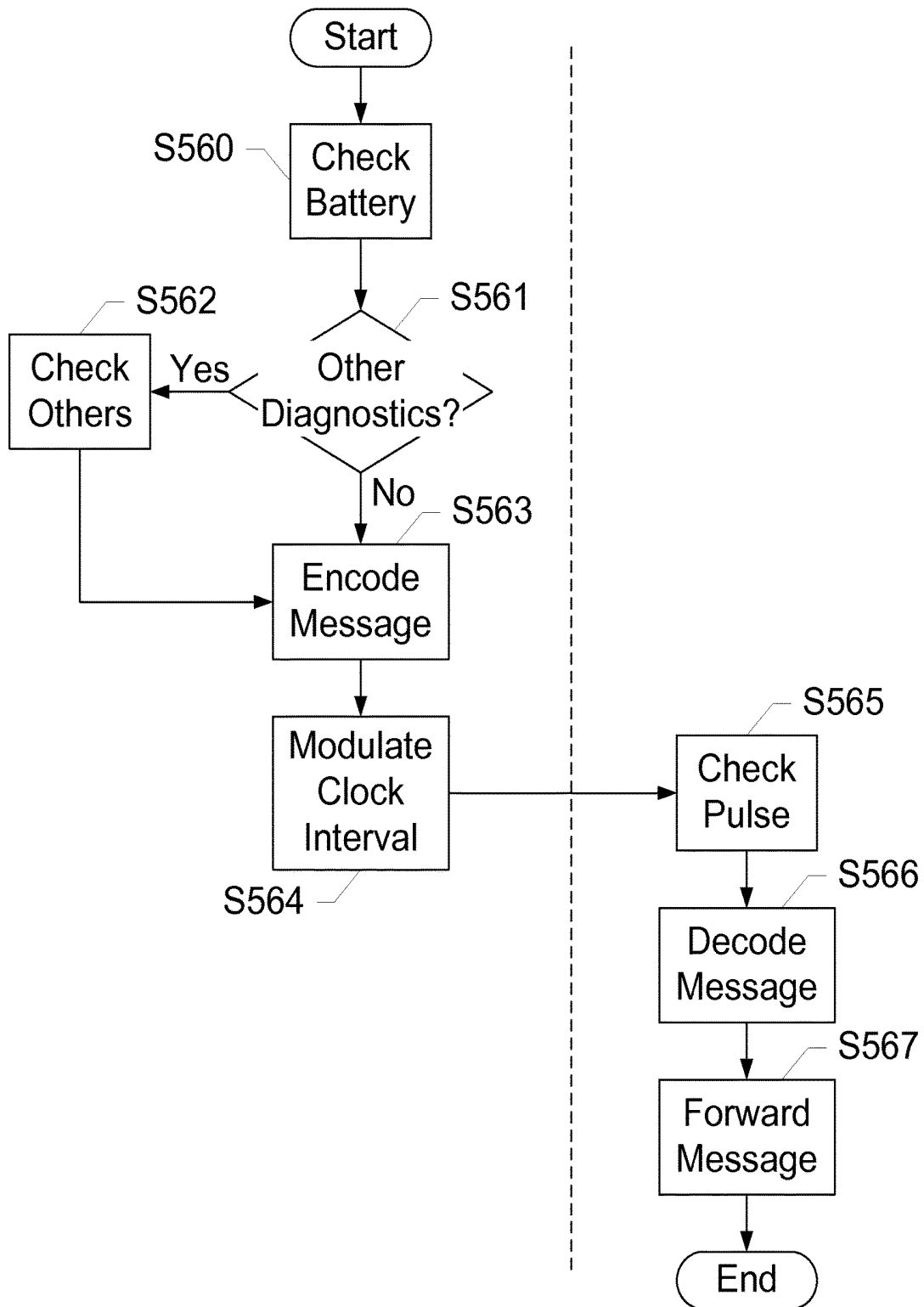
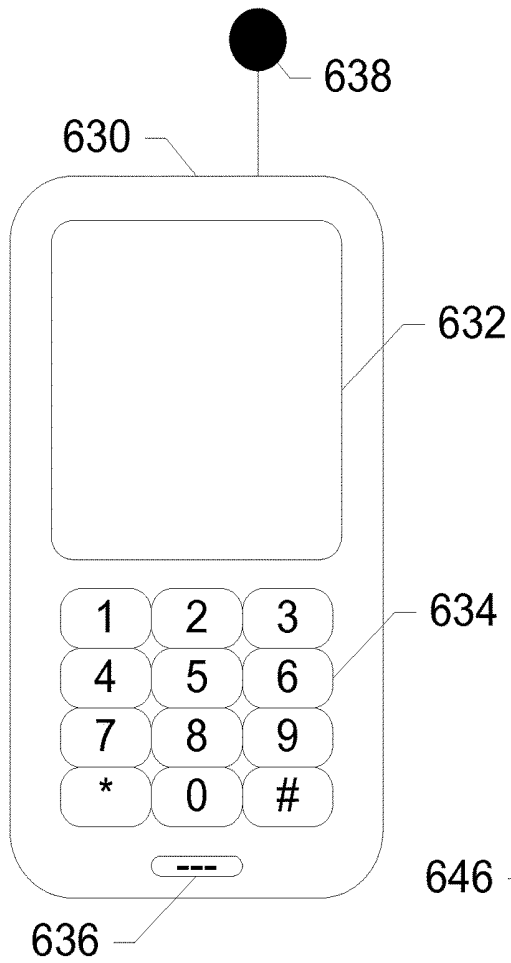
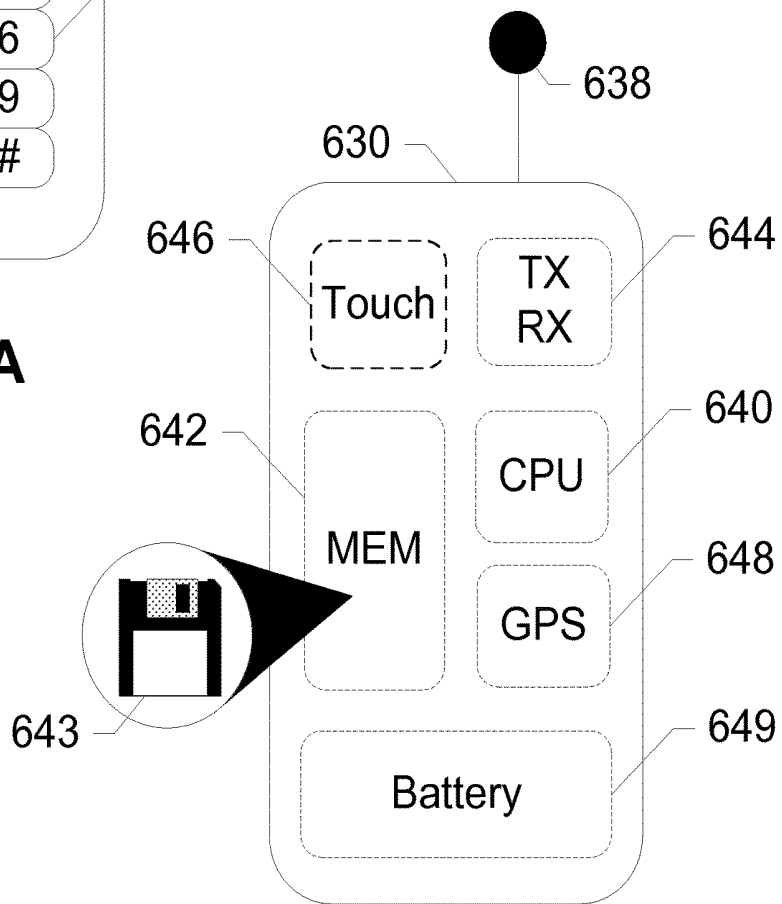


FIG. 5



**FIG. 6A**



**FIG. 6B**

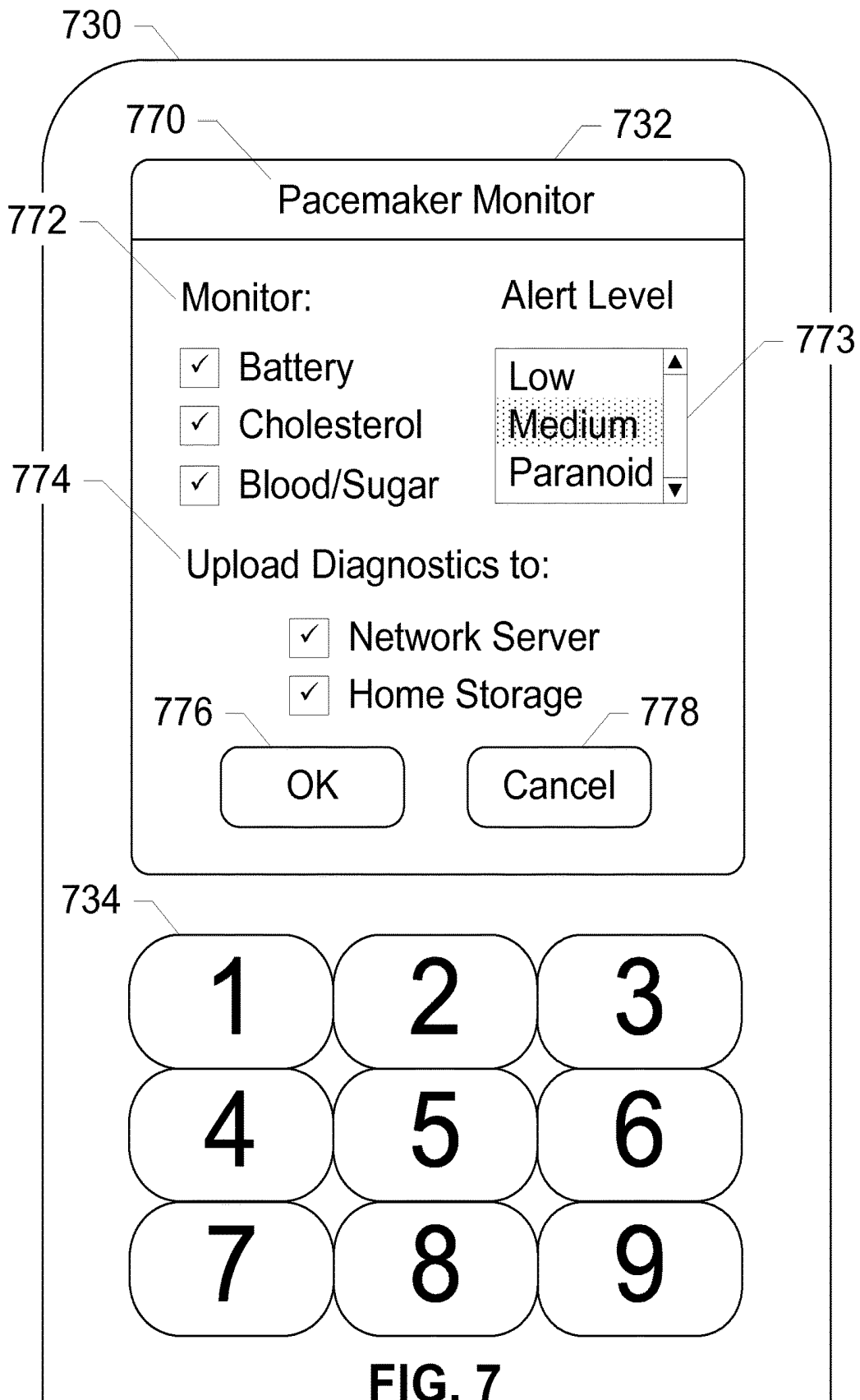


FIG. 7

**MOBILE APPLICATIONS AND METHODS  
FOR CONVEYING PERFORMANCE  
INFORMATION OF A CARDIAC  
PACEMAKER**

**CROSS REFERENCE TO RELATED  
APPLICATIONS**

[0001] This application is a divisional of U.S. patent application Ser. No. 14/871,045 filed on Sep. 30, 2015, which is a continuation of U.S. application Ser. No. 13/191,996 (now U.S. Pat. No. 9,158,890, filed Jul. 27, 2011). All sections of the aforementioned application(s) and patent(s) are incorporated herein by reference in their entirety.

**FIELD OF THE DISCLOSURE**

[0002] The subject disclosure relates to pacemakers. In particular, the subject disclosure relates to pacemakers for conveying performance information of a cardiac pacemaker to an external device.

**BACKGROUND OF THE DISCLOSURE**

[0003] Recipients of cardiac pacemakers are occasionally required to visit their doctors to check up on the performance of their installed pacemakers along with a general check up. The doctor uses devices that can communicate with a pacemaker inductively, i.e., without the need to intrude through skin or other tissues. The devices retrieve performance information from the pacemaker, including battery charge level and any errors in the software controlling the pacemaker. Such equipment is highly specialized, expensive to acquire and expensive to operate with a trained specialist. When not at a medical facility with such equipment and specialists, the pacemaker's performance cannot be remotely monitored. Any sudden onset of performance issues, such as a battery draining at an abnormal rate, may present a life threatening situation that is undetected until it is too late to take action.

[0004] Mobile devices, such as cellular telephones, have become a common tool of everyday life. Cellular telephones are no longer used simply to place telephone calls. With the number of available features rapidly increasing, cellular telephones are now used for storing addresses, keeping a calendar, reading e-mails, drafting documents, etc. These devices are small enough that they can be carried in a pocket or purse all day, allowing a patient to stay in contact almost anywhere. Recent devices have become highly functional, providing applications useful to business professionals as well as the casual patient.

[0005] Mobile devices are frequently used for sending and receiving messages. Such devices may, for instance, send basic text messages using Short Message Service (SMS) and enhanced messages using Multimedia Messaging Service (MMS). Unfortunately, nowadays, the number of abilities also allows mobile devices to introduce new malware propagation vectors such as SMS/MMS messaging and file transfers. MMS messages can embed text, audio, images and video. However, none of these messaging capabilities have been applied to cardiac pacemakers.

[0006] On a worldwide basis there are 3 million people with pacemakers now and it is growing by 600,000 per year and accelerating. Therefore, what are needed are improved devices, systems, and methods to collect and analyze information from a cardiac pacemaker.

[0007] The subject disclosure presents devices, systems, and methods for relaying information from a cardiac pacemaker to an external device. In exemplary embodiments, logic on the pacemaker modulates a heartbeat clock of the pacemaker to encode information onto a blood pressure sequence. This is accomplished by adding or subtracting a small subinterval to or from a pulse repetition interval of the pacemaker. A muscle stimulator beats the heart according to the modulated sequence. A monitoring device external to the body monitors the blood pressure to retrieve the encoded information, or message. The encoded information is then decoded to determine the information in the message. This information may concern the pacemaker as well as other devices within the body that are in communication with the pacemaker such as blood monitors, etc. Since the message is conveyed via simple modulation of the heart beat intervals, no separate transmitter is required in the pacemaker which would otherwise increase cost and decrease battery life.

[0008] The pacemaker performance information may be transmitted to medical entities on a daily basis rather than having to wait for extended intervals between checkups. Potential problems with the pacemaker or its battery are identified much faster, thereby avoiding a life threatening condition. Exemplary embodiments require no more energy than used by existing pacemakers, and do not require a physical redesign. A software modification enables the pacemaker to transmit information through the patient's heartbeat. This reduces the frequency of doctor's appointments, resulting in lower cost to the patient, less strain on medical institutions, lower insurance premiums, and enhanced profit margins for medical entities. Further, the rapidly increasing portion of the population that currently has pacemakers can immediately benefit from the devices and mobile applications disclosed herein.

[0009] In one exemplary embodiment, the subject disclosure is a method for communicating information through a heartbeat. The method includes applying a standard interval clock to stimulate a heartbeat, modifying an interval of the standard interval clock by one of adding and subtracting a subinterval to represent a binary digit, and stimulating a heart muscle according to the modified interval.

[0010] In another exemplary embodiment, the subject disclosure is a device for communicating information through a heartbeat. The device includes a standard interval clock for stimulating a heartbeat, a clock modulator for modifying an interval of the standard interval clock by one of adding and subtracting a subinterval to represent a binary digit, and a muscle stimulator for stimulating a heart muscle according to the modified interval.

[0011] In yet another exemplary embodiment, the subject disclosure is a system for communicating information through a heartbeat. The system includes a pacemaker for applying a standard interval clock to stimulate a heartbeat, modifying an interval of the standard interval clock by one of adding and subtracting a subinterval to represent a binary digit, and stimulating a heart muscle according to the modified interval, and a pulse monitor for receiving the binary digit from the heartbeat.

**BRIEF DESCRIPTION OF THE DRAWINGS**

[0012] FIG. 1 shows a system for transferring information from a cardiac pacemaker, according to an exemplary embodiment of the subject disclosure.

**[0013]** FIG. 2 shows a monitoring device, according to an exemplary embodiment of the subject disclosure.

**[0014]** FIG. 3 shows an internal device coupled to a cardiac pacemaker, according to an exemplary embodiment of the subject disclosure.

**[0015]** FIG. 4 shows a system for transferring information from a patient to a physician center, according to an exemplary embodiment of the subject disclosure.

**[0016]** FIG. 5 shows a method of transferring information from a cardiac pacemaker, according to an exemplary embodiment of the subject disclosure.

**[0017]** FIGS. 6A and 6B respectively show the external and internal components of a mobile device, according to an exemplary embodiment of the subject disclosure.

**[0018]** FIG. 7 shows a pacemaker monitor application on a mobile device, according to an exemplary embodiment of the subject disclosure.

#### DETAILED DESCRIPTION OF THE DRAWINGS

**[0019]** Exemplary embodiments of the subject disclosure include a pacemaker that inserts small deviations in the timing of each heart beat to communicate information. For example, assume the normal period of a heart beat controlled by the pacemaker is exactly sixty beats per minute, or one beat per second exactly. This interval is then modified by a subinterval to convey information about the performance of the pacemaker. For instance, an interval of 0.95 seconds could imply a binary zero while an interval of 1.05 seconds could imply a binary one. In this instance, a subinterval of 0.05 has been added or subtracted to create the binary integer. At an overall average interval of 60 beats per minute, the pacemaker conveys 60 bits of information per minute, and 3600 bits of information per hour. This is likely sufficient to convey most or all of the performance information needed including battery life and performance information for any attached devices. The timing of pulses, or heartbeats, conveys information while jointly serving the purpose of causing the heart beat. To receive this information, or message, a simple and inexpensive systolic blood pressure sensor is placed on the body of the patient. The blood pressure sensor outputs the information through either a wired or wireless connection, such as ETHERNET, BLUETOOTH, WIFI, ZIGBEE, Z-WAVE, etc. The blood pressure sensor uses this connection to communicate across a network, e.g., through a mobile device across a cellular network, to a remote application hosted on an application server accessible by a medical professional. The hosted application monitors the performance information from the message and determines if any performance degradations have occurred. Medical professionals, such as physicians, nurses, etc., also monitor performance and contact the patient or pacemaker owner to schedule a more thorough investigation at a medical facility, if needed.

**[0020]** Exemplary embodiments comprise a mobile device with at least a BLUETOOTH or equivalent transceiver, a cardiac pacemaker, a blood pressure sensor with BLUETOOTH or equivalent transceiver, and a remote application server including a remote application. Performance information of the pacemaker is relayed to the blood pressure sensor through a simple pulse code modulation scheme and then transmitted to a medical entity's remote server for remote diagnostics and proactive discovery of life-threatening performance problems.

**[0021]** "Pacemaker", as used herein and throughout this disclosure, refers to a medical device that uses electrical impulses, delivered by electrodes contacting the heart muscles, to regulate the beating of the heart. "Pulse" or "blood pressure sequence", refers to the beating of the heart. While many pacemakers use a single electrode, pacemakers equipped with multiple electrodes may stimulate different points within the heart to improve synchronization of the heart muscles.

**[0022]** "Mobile device", as used herein and throughout this disclosure, refers to any electronic device capable of wirelessly sending and receiving data. A mobile device may have a processor, a memory, a transceiver, an input, and an output. Examples of such devices include cellular telephones, personal digital assistants (PDAs), portable computers, etc. The memory stores applications, software, or logic. Examples of processors are computer processors (processing units), microprocessors, digital signal processors, controllers and microcontrollers, etc. Examples of device memories that may comprise logic include RAM (random access memory), flash memories, ROMS (read-only memories), EPROMS (erasable programmable read-only memories), and EEPROMS (electrically erasable programmable read-only memories).

**[0023]** "Logic" as used herein and throughout this disclosure, refers to any information having the form of instruction signals and/or data that may be applied to direct the operation of a processor. Logic may be formed from signals stored in a device memory. Software is one example of such logic. Logic may also be comprised by digital and/or analog hardware circuits, for example, hardware circuits comprising logical AND, OR, XOR, NAND, NOR, and other logical operations. Logic may be formed from combinations of software and hardware. On a network, logic may be programmed on a server, or a complex of servers. A particular logic unit is not limited to a single logical location on the network.

**[0024]** Mobile devices communicate with each other and with other elements via a network, for instance, a wireless network, or a wireline network. A "network" can include broadband wide-area networks such as cellular networks, local-area networks (LAN), and personal area networks, such as near-field communication (NFC) networks including BLUETOOTH®. Communication across a network is preferably packet-based; however, radio and frequency/amplitude modulations networks can enable communication between mobile devices using appropriate analog-digital-analog converters and other elements. Communication is enabled by hardware elements called "transceivers." Mobile devices may have more than one transceiver, capable of communicating over different networks. For example, a cellular telephone can include a cellular transceiver for communicating with a cellular base station, a Wi-Fi transceiver for communicating with a Wi-Fi network, and a BLUETOOTH® transceiver for communicating with a BLUETOOTH® device. A network typically includes a plurality of elements that host logic for performing tasks on the network.

**[0025]** In modern packet-based wide-area networks, servers may be placed at several logical points on the network. Servers may further be in communication with databases and can enable mobile devices to access the contents of a database. Billing servers, application servers, etc. are examples of such servers. A server can include several

network elements, including other servers, and can be logically situated anywhere on a service provider's network, such as the back-end of a cellular network. A server hosts or is in communication with a database hosting an account for a patient of a mobile device. The "patient account" includes several attributes for a particular patient, including a unique identifier of the mobile device(s) owned by the patient, relationships with other patients, application usage, location, personal settings, business rules, bank accounts, and other information. A server may communicate with other servers on different networks to update a patient account.

[0026] For the following description, it can be assumed that most correspondingly labeled structures across the figures (e.g., 120 and 220, etc.) possess the same characteristics and are subject to the same structure and function. If there is a difference between correspondingly labeled elements that is not pointed out, and this difference results in a non-corresponding structure or function of an element for a particular embodiment, then that conflicting description given for that particular embodiment shall govern.

[0027] FIG. 1 shows a system for transferring information from a cardiac pacemaker 100, according to an exemplary embodiment of the subject disclosure. The system includes cardiac pacemaker 100 controlling a heart 116 of a patient, and a monitoring device 120. Cardiac pacemaker 100 includes a performance monitor 102, a standard interval clock 104, a clock modulator 106, conversion logic 108, a muscle stimulator 110, an electrode 112, and a battery 114. Standard interval clock 104 produces a standard interval of time that triggers muscle stimulator 110 to send an electrical impulse. Performance monitor 102 monitors the functioning of the components of cardiac pacemaker 100, such as an amount of charge remaining on battery 114. Performance monitor 102 may further monitor any device in communication with cardiac pacemaker 100. When information detected by performance monitor 102 needs to be reported, clock modulator 106 generates a modulation signal representing the information to be reported. Conversion logic 108 modulates the signal using standard interval clock 104 to encode the information. This modulation slightly increases or decreases each of the standard intervals to encode the information onto the impulse interval. For instance, clock modulator 106 may slightly increase the standard interval to represent the binary integer '1' and slightly decrease the standard interval to represent the binary integer '0'. A combination of '1's' and '0's' over a series of impulse intervals sends encoded information to muscle stimulator 110.

[0028] Muscle stimulator 110 of cardiac pacemaker 100 is electrically coupled to an electrode 112 that extends into the sinoatrial node of heart 116. Muscle stimulator 110 sends an electrical impulse through electrode 112 to cause heart 116 to beat according to the modulated signal. The information, or message, encoded onto the impulse interval is reflected in the heartbeat, and consequently, the pulse or blood-pressure sequence includes this message. The pulse or blood-pressure sequence created by heart 116 is read by monitoring device 120. Monitoring device 120 may be, for instance, a pulse monitor, a mobile device capable of reading a pulse, a blood pressure monitor, etc.

[0029] In other exemplary embodiments, the pacemaker is equipped with a memory and processor. The memory contains logic for performing all of the functions of the performance monitor 102, standard interval clock 104, clock

modulator 106, and conversion logic 108 of pacemaker 100. Using software to perform the functions may require more power to operate, but benefits from the ability to update the logic on the memory without replacing any hardware. Further, although a pacemaker is shown inserted into a human heart, exemplary embodiments of the pacemaker can be used in any animal.

[0030] As described above, the difference between a standard interval and a modified interval is the addition or subtraction of a subinterval. In exemplary embodiments, the subinterval is significantly less than the standard interval, such as one-twentieth ( $1/20$ ) of the standard interval. Variations in human behavior may cause the pulse monitor to pick up pulse intervals that are skewed from what was intended. For instance, the patient may cough, or be engaged in strenuous activity. Exemplary embodiments of the pulse monitor use block error checking, cyclic redundancy checking, trellis coding, etc. to compensate for these variations and improve the accuracy of the performance information.

[0031] In further embodiments, the performance is scheduled to be monitored and transmitted to a systolic blood pressure sensor during sleep or any other time where body movements are minimal or otherwise do not result in a misreading of pressure. This avoids errors caused by the sinoatrial node of the heart causing contractions at a rate faster than otherwise provided by the pacemaker. Such errors may be further minimized using error checking and recovery, as explained herein. Use of such schemes reduces the information content per cardiac pulse by up to half, while retaining sufficient information volume to indicate the performance of the cardiac pacemaker.

[0032] FIG. 2 shows a monitoring device 220, according to an exemplary embodiment of the subject disclosure. Monitoring device 220 includes a pulse monitor 222, a message decoder 224, and a wireless transceiver 226. Pulse monitor 220 may be worn or placed around the wrist, chest, or any other location on a patient where a pulse or heartbeat may be detected. Pulse monitor 222 detects the pulse of the patient and measures the timing of the pulse to a degree or resolution where modulated intervals are distinguishable from unmodulated intervals. In other words, the resolution of the pulse monitor must be high enough to distinguish modulated intervals from unmodulated intervals. These measurements are sent to message decoder 224. Message decoder 224 contains logic to decode a message from the binary encoded pulse of the patient. Slight deviations to a standard pulse interval encoded by a cardiac pacemaker create this binary message that is decoded by message decoder 224. The decoded message is then sent to wireless transceiver 226. Wireless transceiver 226 may be a BLUETOOTH transceiver, may be a cellular transceiver, etc., and communicates the message to a mobile device, to a wireline device, to a physician center, etc.

[0033] In exemplary embodiments of the subject disclosure, the pulse is detected through any type of pulse detection. Many devices are used today to determine pulse, from stethoscopes to more sophisticated technologies including touch screen technology, etc. Many of these require constant contact with the skin, hence any wearable embodiment will become apparent to those of ordinary skill in the art in light of this disclosure.

[0034] In exemplary embodiments of the subject disclosure, the pulse monitor may lack a message decoder. In these embodiments, the pulse or blood pressure sequence is moni-

tored and stored on a memory. The stored information may then be transmitted to a mobile device having decoding logic therein, or to a physician center where it is decoded. In embodiments of the subject disclosure, the pulse monitor further includes a display. In these embodiments, after the message is decoded, it is visible on the display. Thus, the patient is notified almost instantly of any status concerning the cardiac pacemaker or any device in communication with the cardiac pacemaker. In embodiments of the pulse monitor lacking a message decoder, the message may be decoded by the mobile device, physician center, etc., and sent back to the pulse monitor for display.

[0035] According to further embodiments of the subject disclosure, the monitoring device may itself be connected to a telephone line. In these embodiments, the monitoring device uses the telephone line to send the encoded or decoded message to another device, to a physician center, etc.

[0036] FIG. 3 shows an internal device 318 coupled to a cardiac pacemaker 300, according to an exemplary embodiment of the subject disclosure. In this embodiment, internal device 318 is within a patient's body. Internal device 318 monitors or tests one or more measurable aspects of the patient's body, including but not limited to blood/sugar, cholesterol, insulin, iron, or any other measurable aspect of the patient's body. Internal device 318 sends this information to cardiac pacemaker 300 through an electric coupling to cardiac pacemaker 300. A clock modulator within cardiac pacemaker 300 modulates the standard interval to encode this information into the pulse of the patient to be read by a pulse or blood pressure meter as described herein.

[0037] In exemplary embodiments, virtually any device may be in communication with the pacemaker. Because the pacemaker does not have a wireless transceiver, the communication needs to be wired. Non-medical devices may be used as well, such as GPS implants, etc.

[0038] FIG. 4 shows a system for transferring information from a patient to a physician center, according to an exemplary embodiment of the subject disclosure. In this embodiment, the system includes a cardiac pacemaker 400, a blood monitor 418, a pulse monitor 420, a mobile device 430, a network 450, a physician server 452, a physician database 454, and a physician 456. Pacemaker 400 delivers performance information through the pulse of its patient as described with respect to the several embodiments disclosed herein. Pacemaker 400 also communicates with blood monitor 418 to receive performance and diagnostic information. This information is received by pacemaker 400 and communicated via the pulse.

[0039] Pacemaker 400 wirelessly communicates the information to pulse monitor 420, which detects the pulse of the patient and measures the timing of the pulse to a degree, or resolution, where modulated intervals are distinguishable from unmodulated intervals. A message can be decoded once enough modulated intervals are received. The message contains diagnostics, performance information, maintenance information, etc. Pulse monitor 420 forwards this message to mobile device 430. Mobile device 430 reads the message, determines if any action or functions are to be executed, and executes any actions or functions based on the content of the message, such as alerting the patient, activating a GPS receiver to determine a location of the patient, etc.

[0040] Mobile device 430 then forwards the message to physician server 452 via network 450. Network 450 may be

a cellular network, local area network, WiFi network, personal area network (PAN), or any other communication network. Physician server 452 processes the message by adding new information to physician database 454, and analyzing the information for further action. If the contents of a message warrant an action, the message may be flagged as needing attention from physician 456. Physician 456 monitors the results of the analysis of physician server 452, and alerts patients of any actions that need to be performed, such as providing a course of treatment, or scheduling an in-person diagnosis or medical test. Physician database 454 further stores these messages and any additional diagnostic information so that trends and statistics can be computed over time.

[0041] In other embodiments, additional devices such as glucose monitors, blood oxygen sensors, etc. are in wired communication with the pacemaker within or external to the patient's body. In some embodiments, the pulse monitor includes logic to analyze the message and perform a task based on the message. For example, if the pulse monitor receives a message indicating a low pacemaker charge, the pulse monitor alerts the user immediately. In this way, the mobile device is not required for simple alerts, but can still be used to forward information to the physician server. The pulse monitor may have additional equipment to announce alerts such as a speaker or display.

[0042] In exemplary embodiments of the subject disclosure, network 450 is a cellular network. A cellular network provides access to a wide-area radio network for communication between devices in different locations, such as mobile device 430 and physician server 452. Service providers such as wireless carriers typically provide service to a geographic market area by dividing the area into many smaller areas or cells. Each cell is serviced by a radio transceiver. Base transceiver stations connect to other elements of the cellular network that are known in the art and therefore not shown. For instance, base transceiver stations connect to Mobile Switching Centers (MSCs) through landlines, gateways, or other communication links, and the MSCs may, in turn, be connected via landlines to the Public Switched Telephone Network (PSTN), to other cellular networks, to IP networks, etc. Many other components are present in the cellular network, but are not presented for sake of simplicity. These components will be apparent to one of ordinary skill in the art in light of this disclosure.

[0043] In further embodiments, the messages are sent to a home medical server. A home medical server is located at the patients dwelling and can perform a greater analysis than the mobile device may be capable of. The home medical server may also serve as a backup of the physician server. Messages may be sent virtually anywhere on the network to be stored. In some exemplary embodiments, the mobile device is in communication with physician software within either or both of the mobile device and the physician server for processing and analyzing the information. A physician is used as an example in FIG. 4. However, many medical professionals can be used to monitor health information. In some cases, specialists are used to monitor a specific aspect of a patient's health.

[0044] FIG. 5 shows a method for transferring information from a cardiac pacemaker to a message decoder, according to an exemplary embodiment of the subject disclosure. In this embodiment, logic on the cardiac pacemaker checks a level of a battery S560. The logic then determines whether

any other diagnostics are necessary **S561**. These diagnostics include an analysis of the performance of the cardiac pacemaker, or may be received from any device in communication with the cardiac pacemaker. If other diagnostics are necessary, the other diagnostics are checked **S562**. With all desired diagnostics checked, or if no diagnostics are needed, the logic on the cardiac pacemaker is used to encode a message containing all received diagnostic information **S563**. The message is encoded by modulating a clock interval of the cardiac pacemaker **S564** with one or more sub-intervals as described herein. The modulation of the clock interval causes the muscle stimulator to stimulate the sinoatrial node of the heart, resulting in a heartbeat corresponding to the modulated clock.

**[0045]** A monitoring device such as a pulse monitor or a blood-pressure monitor checks the pulse of the patient **S565**. A message decoder in communication with the monitoring device decodes the message **S566**. The message decoder may be included within the monitoring device, or within a mobile device in communication with the monitoring device, etc. The message is then forwarded **S567** to a physician center, to a mobile device, to a wireline device, etc. over a wireless or wired connection.

**[0046]** In some embodiments, when the pacemaker checks connected devices for diagnostics, the connected device performs its own diagnostics and performance and sends the results in a message to the pacemaker. This message can be raw, requiring encoding, or already encoded and ready to be sent through the pulse of the patient. Communication between electronic devices uses binary encoding often. However, the connected device may encode differently than the pacemaker and the pulse monitor. Encoding may have to be translated in embodiments with connected devices of different binary encoding schemes.

**[0047]** FIGS. 6A and 6B respectively show the external and internal components of a mobile device **630**, according to an exemplary embodiment of the subject disclosure. Mobile device **630** includes a display **632**, a keypad **634**, a microphone **636**, and an antenna **638**. Mobile device **630** further includes a transceiver **644**, a touch sensor **646**, a battery **648**, a central processing unit (CPU) **640**, and a memory **642**. Display **632** is an LCD, LED or other type of display on which a patient can view selections, numbers, letters, etc. Display **632** allows the patient to view messages being created or received, view contacts, view dialed numbers, etc. Display **632** may also be a touch screen, thereby being used as an input device as well. In embodiments not using a touch screen, a keypad is typically used as an input device, for instance, to type a telephone number or a message. Such a keypad may be a numerical keypad, a QWERTY keyboard, etc. Microphone **636** allows the patient to verbally communicate with others using mobile device **630**. Antenna **638** is a transducer designed to transmit or receive electromagnetic waves to and from a network.

**[0048]** In conjunction with antenna **638**, transceiver **644** allows mobile device **630** to wirelessly communicate with a cellular network or with other mobile devices across the cellular network, using near field communications, etc. Transceiver **644** may be a cellular transceiver, wireless transceiver, etc., and includes combinations of transceivers to communicate with assorted wireless networks. Battery **649** provides power to each of the components of mobile device **630**, and can include an interface to an external power supply. CPU **640** controls components of mobile

device **630** according to instructions in logic **643** stored on memory **642**. Memory **642** comprises any computer readable medium, such as RAM, ROM, etc. A GPS receiver **648** enables location determination to facilitate location-based services for mobile device **630**.

**[0049]** In some embodiments, the mobile device is capable of reading the pulse of the patient without the need for a separate pulse monitoring device. These mobile devices are equipped with a pulse sensor such as a touch screen, etc. Two-way capacitive transducers and other touch screen technologies can detect a variety of human stimuli including the conductivity of skin; the specific motions associated with natural muscular twitches; the pressure variations associated with pulse; the temperature of skin; etc. Such technologies use a variety of means and metrics to detect these stimuli, including galvanic response for measuring skin conductivity, and are included in commonly owned U.S. patent application Ser. No. 12/334,377, which is hereby incorporated by reference in its entirety. This way, the mobile device reads the pulse and decodes the message for forwarding to the physician server, home server, etc. However, some messages may take several minutes to transmit from the pacemaker to the mobile device. Therefore separate pulse monitors and mobile devices are used for longer messages. The pulse monitor may be worn in a way such that it makes constant contact with the patient's wrist, neck, or skin in some other position capable of constant pulse monitoring. As a result, the patient does not have to actively check the pulse with the mobile device. The worn pulse monitor can receive messages passively and alert the patient when necessary. Many mobile devices run standard operating systems such as 105, ANDROID, WINDOWS MOBILE, SYMBIAN, etc. Exemplary embodiments of the logic on the memory are capable of running under these operating systems.

**[0050]** FIG. 7 shows a pacemaker monitor application **770** on a mobile device **730**, according to an exemplary embodiment of the subject disclosure. Pacemaker monitor **770** includes a monitoring selection **772**, an alert level **773**, an upload location **774**, an OK button **776** and a Cancel button **778**. Monitoring selection **772** allows the patient to select which performance or health attributes to monitor. Among the choices are the pacemaker battery, the patient's cholesterol, and the patient's blood/sugar level. With all of these choices checked, mobile device **730** will monitor messages from the pacemaker concerning the pacemaker battery, the patient's cholesterol level, and the patient's blood/sugar level. Other options are possible and will be apparent to those having ordinary skill in the art in light of this disclosure.

**[0051]** Alert level **773** enables the patient to determine when and how to be alerted. In this embodiment, the selections include low, medium, and paranoid. Each setting may be linked to a separate alert tone, level, and method. Other embodiments may allow more detailed settings, such as per monitor alert levels. Upload location **774** enables the patient to select which server or network location to archive messages. The network server is most likely a physician server, while the home storage is most likely a home backup server. When the patient has changed any of the settings on the screen, the patient activates OK button **776** to save the changes and continue using mobile device **730**. If the patient has made changes, but does not wish to save them, then the

patient activates Cancel button 778. Buttons 776 and 778 are activated using keypad 734 or touch screen 732.

**[0052]** The foregoing disclosure of the exemplary embodiments of the subject disclosure has been presented for purposes of illustration and description. It is not intended to be exhaustive or to limit the subject disclosure to the precise forms disclosed. Many variations and modifications of the embodiments described herein will be apparent to one of ordinary skill in the art in light of the above disclosure. For instance, communication between mobile devices and network elements can be accomplished by Internet Protocol (IP) addressing, Session Initiation Protocol (SIP) signaling over an IP Multimedia System (IMS), Voice over IP (VoIP), etc. The scope of the subject disclosure is to be defined only by the claims appended hereto, and by their equivalents.

**[0053]** Further, in describing representative embodiments of the subject disclosure, the specification may have presented the method and/or process of the subject disclosure as a particular sequence of steps. However, to the extent that the method or process does not rely on the particular order of steps set forth herein, the method or process should not be limited to the particular sequence of steps described. As one of ordinary skill in the art would appreciate, other sequences of steps may be possible. Therefore, the particular order of the steps set forth in the specification should not be construed as limitations on the claims. In addition, the claims directed to the method and/or process of the subject disclosure should not be limited to the performance of their steps in the order written, and one skilled in the art can readily appreciate that the sequences may be varied and still remain within the spirit and scope of the subject disclosure.

What is claimed is:

1. A method comprising:

monitoring, by a processing system including a processor, a pulse monitor and a pacemaker of a system comprising the pulse monitor, the pacemaker, and an internal device separate from the pacemaker, wherein the pulse monitor is coupled to the pacemaker and the internal device;

monitoring, by the processing system, performance of the internal device to obtain monitored information;

determining, by the processing system, a reporting requirement based on the monitored information; and

responsive to the reporting requirement:

generating, by the processing system, a modulation signal based on the monitored information;

initiating, by the processing system, a timer to stimulate a heart muscle of a patient according to an interval to cause a first adjustment of a heartbeat associated with the heart muscle;

modifying, by the processing system, the interval by adding or subtracting a subinterval to generate a modified interval, wherein the subinterval is representative of a binary digit, according to the modulation signal; and

stimulating, by the processing system, the heart muscle according to the modified interval to cause a second adjustment of the heartbeat, wherein the pulse monitor detects a pulse based on the second adjustment of the heartbeat and according to the modulation signal.

2. The method of claim 1, wherein the internal device comprises a medical device, and

wherein the monitored information comprises a level of sugar, cholesterol, insulin, iron, or any combination thereof, within a body of the patient.

3. The method of claim 2, wherein a timing of the pulse is measured by the pulse monitor to distinguish modified and unmodified pulse intervals.

4. The method of claim 1, wherein the modifying of the interval further comprises encoding the monitored information as an encoded binary message.

5. The method of claim 1, wherein a message is decoded by pulse monitor from the binary digit, wherein the binary digit is one of a plurality of binary digits representing a string of binary digits.

6. The method of claim 5, wherein one of block error checking, cyclic redundancy checking, and trellis coding is used by the pulse monitor to verify the message.

7. The method of claim 1, wherein the modifying of the interval further comprises encoding the monitored information as an encoded binary message, and wherein activation of a GPS receiver is initiated by a decoding of the encoded information to determine a location of the patient.

8. A method comprising:

monitoring, by a processing system including a processor, a pulse monitor and an internal device implanted within a body of a patient to obtain monitored information, wherein the pulse monitor is coupled to a pacemaker and the internal device, and wherein the internal device is separate from the pacemaker;

generating, by the processing system, a modulation signal based on the monitored information;

initiating, by the processing system, a timer to stimulate a heart muscle of a patient according to an interval to cause a first adjustment of a heartbeat associated with the heart muscle;

modifying, by the processing system, the interval by adding or subtracting a subinterval to generate a modified interval, wherein the subinterval is representative of a binary digit, according to the modulation signal, wherein, the heart muscle is stimulated according to the modified interval to cause a second adjustment of the heartbeat, wherein a pulse monitor detects a pulse based on the second adjustment of the heartbeat and according to the modulation signal, wherein the pulse comprising the binary digit, based on detection by the pulse monitor of the second adjustment to the heartbeat, is forwarded to a mobile device, and wherein the mobile device comprises decoding logic adapted to decode information, to obtain decoded information based on the binary digit; and

obtaining, by the processing system, the decoded information obtained by way of the mobile device,

wherein the internal device communicates with the pacemaker via a wired connection, and wherein a signal provided by the internal device to the pacemaker via the wired connection represents a measurement regarding a measurable aspect of the patient.

9. The method of claim 8, wherein the pulse monitor communicates with the mobile device, and

wherein the mobile device reads a decoded message to determine an action to be performed based on content of the decoded message.

10. The method of claim 9, wherein the action comprises activating a GPS receiver to determine a location of a patient.

11. The method of claim 9, wherein the decoded message is communicated to a physician server, and

wherein the decoded message is processed at the physician server by adding information to a physician database coupled to the physician server.

12. The method of claim 8, wherein modifying of the interval further comprises encoding, by the processing system, the measurement as an encoded binary message,

wherein the internal device comprises a blood monitor, and

wherein the pacemaker receives performance and diagnostic information from the blood monitor and communicates the performance and diagnostic information via the encoded binary message.

13. A non-transitory, machine-readable storage medium, comprising executable instructions that, when executed by a system comprising a pulse monitor, a pacemaker, an internal device separate from the pacemaker, and a processing system including a processor coupled to the pulse monitor and the pacemaker, wherein the processing system facilitates performance of operations, the operations comprising:

monitoring, by the pacemaker, performance of the internal device to obtain monitored information;

determining, by the pacemaker, a reporting requirement based on the monitored information; and

responsive to the reporting requirement:

generating, by the pacemaker, a modulation signal based on the monitored information;

initiating, by the pacemaker, a timer to stimulate a heart muscle of a patient according to an interval to cause a first adjustment of a heartbeat associated with the heart muscle;

modifying, by the pacemaker, the interval by adding or subtracting a subinterval to generate a modified interval, wherein the subinterval is representative of a binary digit, according to the modulation signal; and

stimulating, by the pacemaker, the heart muscle according to the modified interval to cause a second adjustment of the heartbeat, wherein the pulse monitor detects a pulse based on the second adjustment of the heartbeat and according to the modulation signal.

14. The non-transitory, machine-readable storage medium of claim 13, wherein the pulse monitor communicates with a mobile device, and

wherein the mobile device reads a decoded message to determine an action to be performed based on content of the decoded message.

15. The non-transitory, machine-readable storage medium of claim 14, wherein the action comprises activating a GPS receiver to determine a location of a patient.

16. The non-transitory, machine-readable storage medium of claim 14, wherein the decoded message is communicated to a physician server, and

wherein the decoded message is processed at the physician server by adding information to a physician database coupled to the physician server.

17. The non-transitory, machine-readable storage medium of claim 13, wherein modifying the interval comprises encoding the monitored information as an encoded binary message,

wherein the internal device comprises a blood monitor, and

wherein the pacemaker receives performance and diagnostic information from the blood monitor and communicates the performance and diagnostic information via the encoded binary message.

18. The non-transitory, machine-readable storage medium of claim 13, wherein the pulse monitor decodes a message from the binary digit, and

wherein the binary digit is one of a plurality of binary digits representing a string of binary digits.

19. The non-transitory, machine-readable storage medium of claim 18, wherein the pulse monitor uses one of block error checking, cyclic redundancy checking, and trellis coding to verify the message.

20. The non-transitory, machine-readable storage medium of claim 13, wherein the modifying of the interval further comprises encoding the monitored information as an encoded binary message, and

wherein activation of a GPS receiver is initiated by a decoding of the encoded binary message to determine a location of the patient.

\* \* \* \* \*

专利名称(译)	用于传递心脏起搏器性能信息的移动应用和方法		
公开(公告)号	<a href="#">US20190143129A1</a>	公开(公告)日	2019-05-16
申请号	US16/245610	申请日	2019-01-11
申请(专利权)人(译)	AT & T移动II LLC		
当前申请(专利权)人(译)	AT & T移动II LLC		
[标]发明人	MEREDITH SHELDON KENT HILLIARD BRANDON B KOSSEIFI MARIO		
发明人	MEREDITH, SHELDON KENT HILLIARD, BRANDON B. KOSSEIFI, MARIO		
IPC分类号	A61N1/372 A61B5/00 G16H40/40 A61B5/0205 A61N1/37		
CPC分类号	A61N1/37282 A61B5/0028 A61B5/0031 G16H40/40 A61B5/0205 A61N1/3706 A61N1/3702 A61N1/3727 A61B5/02438 A61B5/145 A61B2505/07 A61B2560/0204 A61B2560/0271 A61N1/3708 G06F19/00 G06F19/3418 G06F19/3481 G16H20/40 G16H40/63		
外部链接	<a href="#">Espacenet</a>	<a href="#">USPTO</a>	

摘要(译)

公开了用于将信息从心脏起搏器中继到外部设备的装置，系统和方法。起搏器上的逻辑调制起搏器的心跳时钟，通过向起搏器的脉冲重复间隔添加或减去小的子间隔来将信息编码到血压序列上。肌肉刺激器根据调制的序列击败心脏。身体外部的监测装置监测血压以检索编码信息或消息。然后对编码信息进行解码以确定消息中的信息。这些信息可能涉及起搏器以及身体内与起搏器通信的其他设备，如血液监测器等。由于通过心跳间隔的简单调制传达信息，起搏器中不需要单独的发射器。否则会增加成本并缩短电池寿命。

