



US 20190029580A1

(19) **United States**

(12) **Patent Application Publication**
Kiani et al.

(10) **Pub. No.: US 2019/0029580 A1**
(43) **Pub. Date: Jan. 31, 2019**

(54) **NON-INVASIVE PHYSIOLOGICAL SENSOR COVER**

Publication Classification

(71) Applicant: **MASIMO CORPORATION**, Irvine, CA (US)

(51) **Int. Cl.**
A61B 5/1455 (2006.01)
A61B 5/024 (2006.01)
A61B 5/00 (2006.01)
A61B 5/145 (2006.01)

(72) Inventors: **Abraham Mazda Kiani**, San Juan Capistrano, CA (US); **Massi Joe E. Kiani**, Laguna Niguel, CA (US)

(52) **U.S. Cl.**
CPC *A61B 5/14552* (2013.01); *A61B 5/02416* (2013.01); *A61B 5/6826* (2013.01); *A61B 5/02427* (2013.01); *A61B 5/6819* (2013.01); *A61B 5/6829* (2013.01); *A61B 5/14532* (2013.01); *A61B 5/6816* (2013.01); *A61B 5/6838* (2013.01); *A61B 5/6832* (2013.01); *A61B 5/14546* (2013.01)

(21) Appl. No.: **16/149,533**

(22) Filed: **Oct. 2, 2018**

Related U.S. Application Data

(63) Continuation of application No. 15/968,393, filed on May 1, 2018, which is a continuation of application No. 15/046,954, filed on Feb. 18, 2016, now Pat. No. 9,980,667, which is a continuation of application No. 14/512,945, filed on Oct. 13, 2014, now Pat. No. 9,295,421, which is a continuation of application No. 13/919,692, filed on Jun. 17, 2013, now Pat. No. 8,886,271, which is a continuation of application No. 12/844,720, filed on Jul. 27, 2010, now Pat. No. 8,473,020.

(60) Provisional application No. 61/229,682, filed on Jul. 29, 2009.

(57) **ABSTRACT**

A sensor cover according to embodiments of the disclosure is capable of being used with a non-invasive physiological sensor, such as a pulse oximetry sensor. Certain embodiments of the sensor cover reduce or eliminate false readings from the sensor when the sensor is not in use, for example, by blocking a light detecting component of a pulse oximeter sensor when the pulse oximeter sensor is active but not in use. Further, embodiments of the sensor cover can prevent damage to the sensor. Additionally, embodiments of the sensor cover prevent contamination of the sensor.

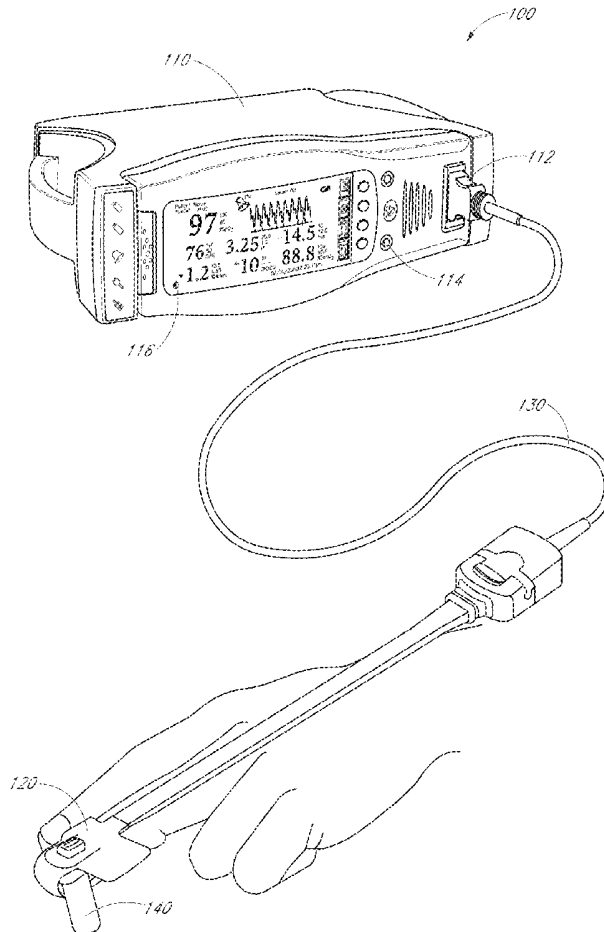

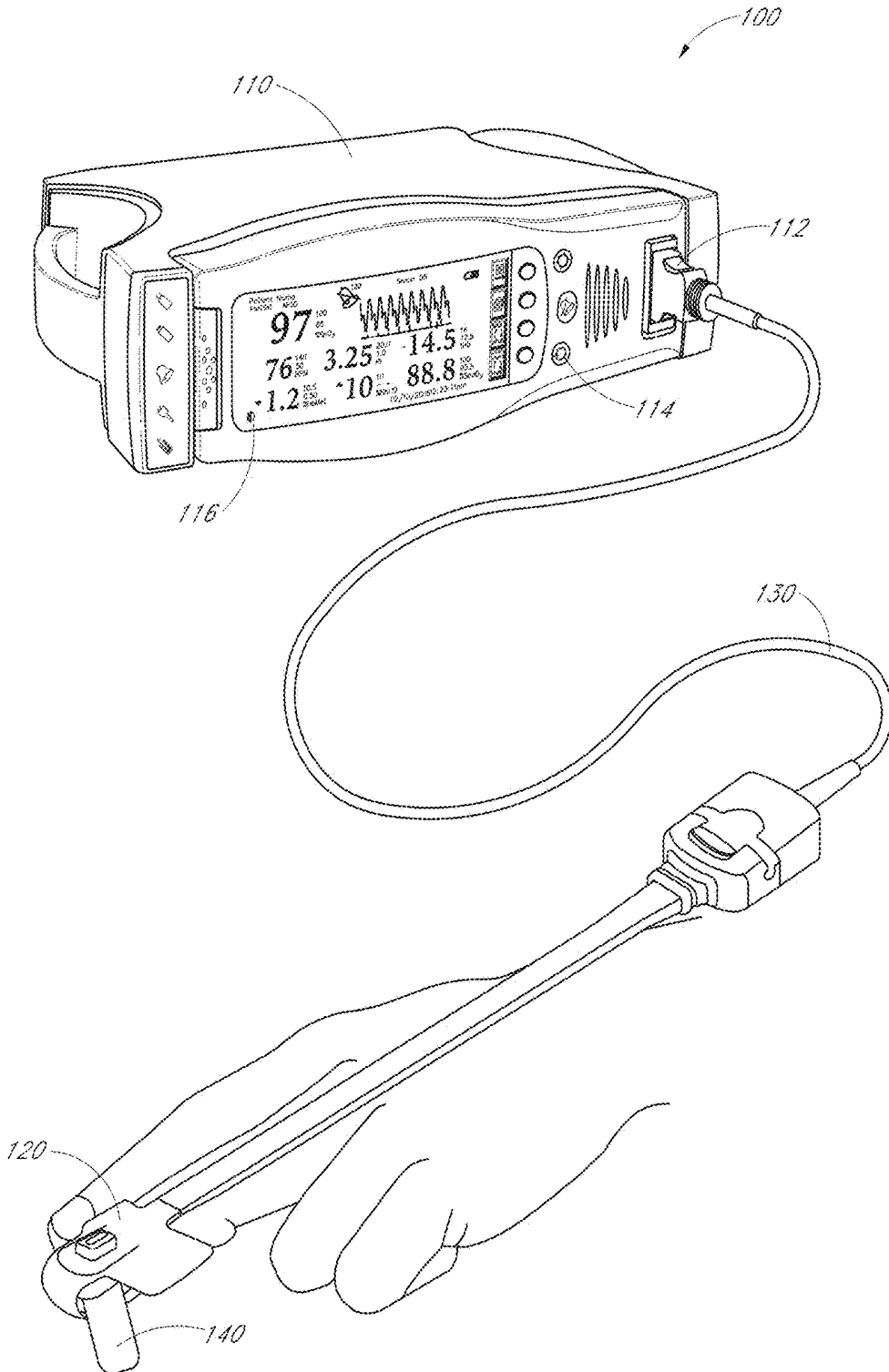

FIG. 1

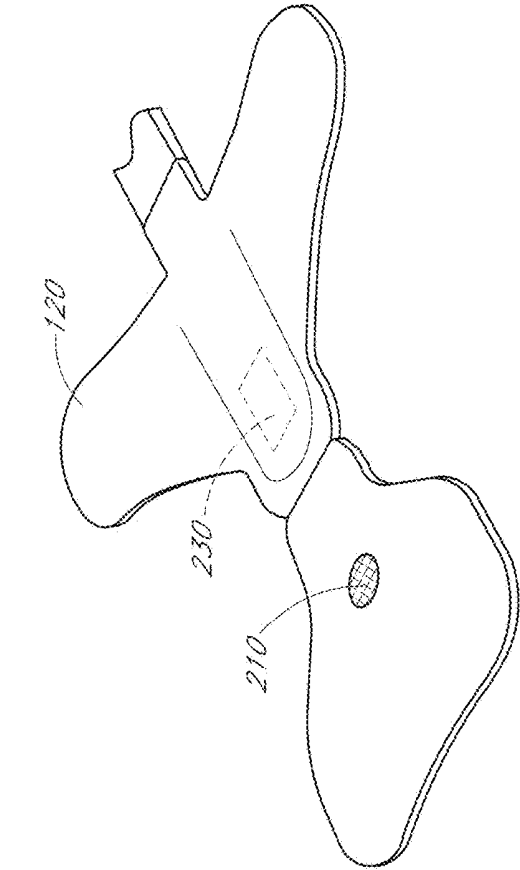

FIG. 2B

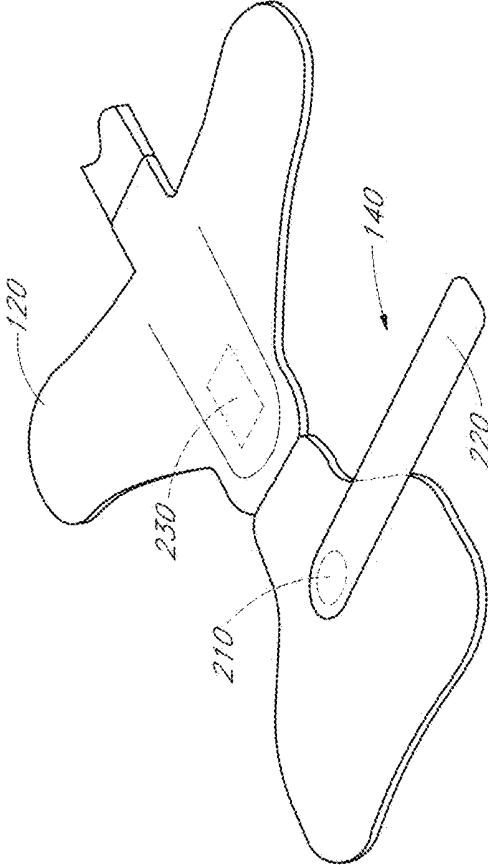

FIG. 2A

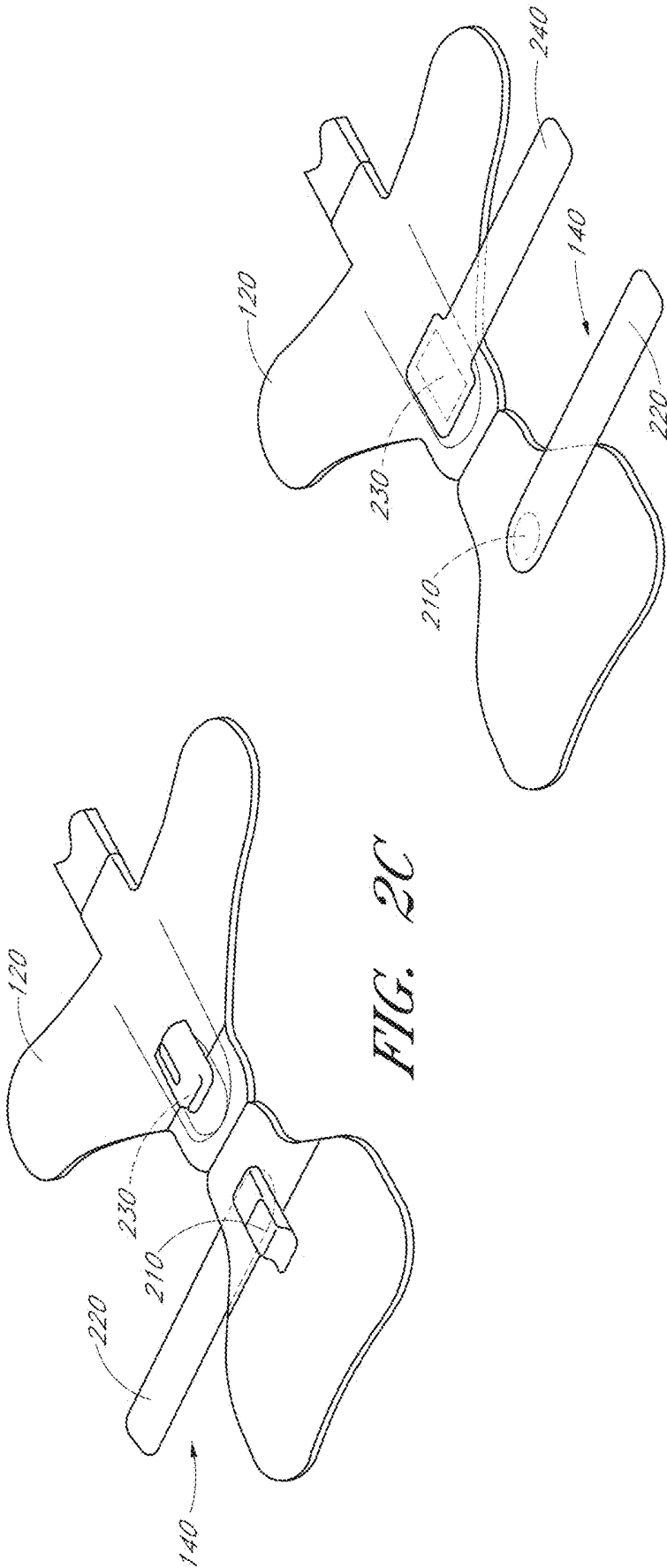
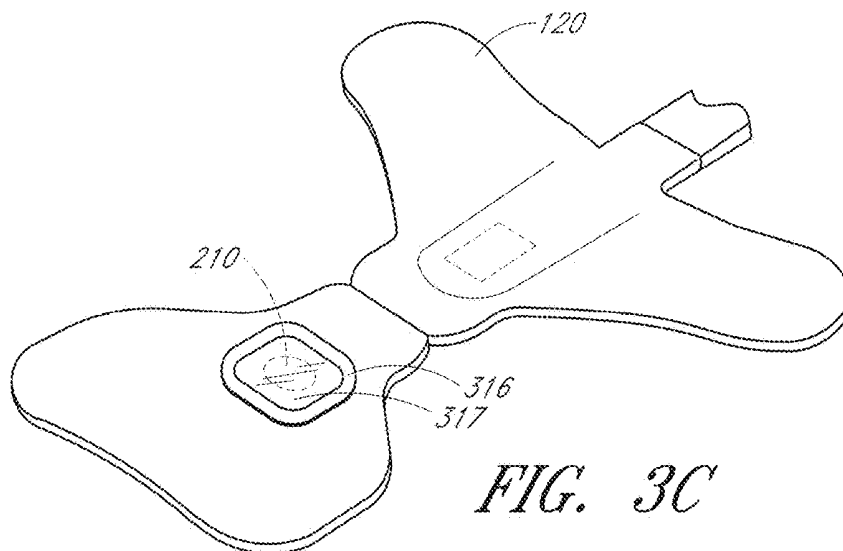
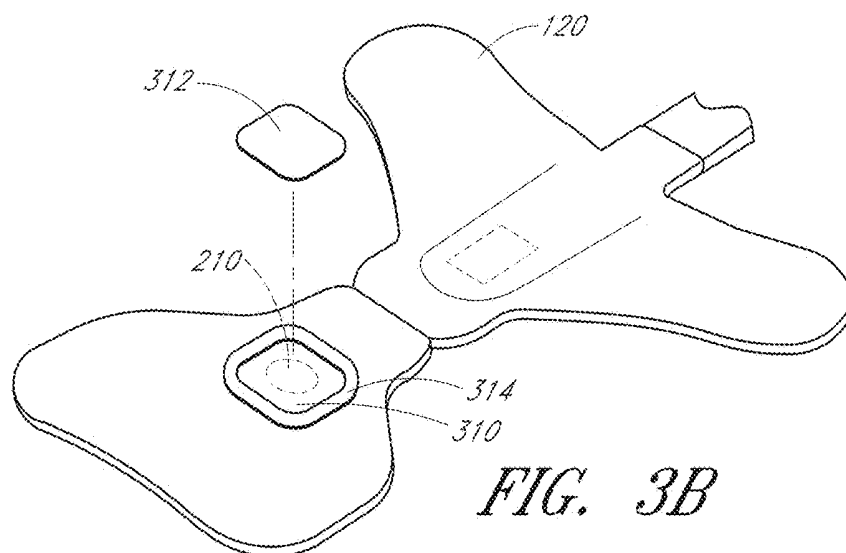
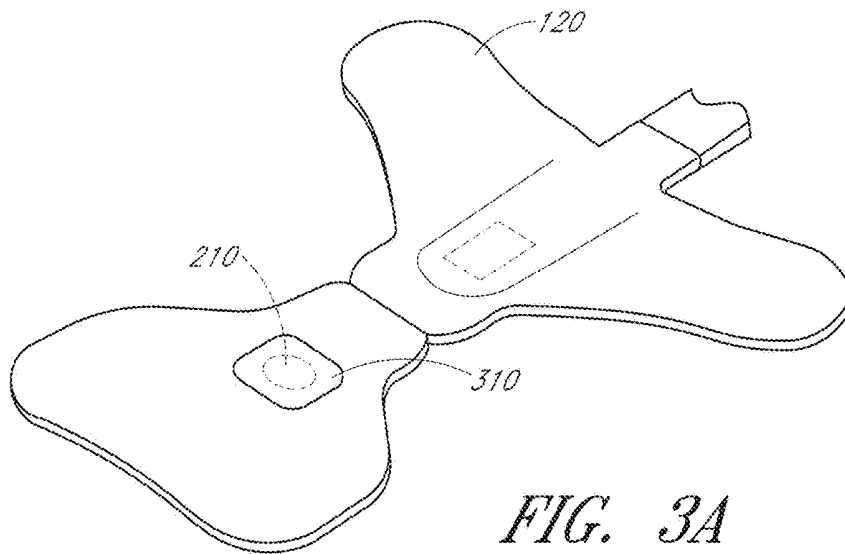

FIG. 2C

FIG. 2D



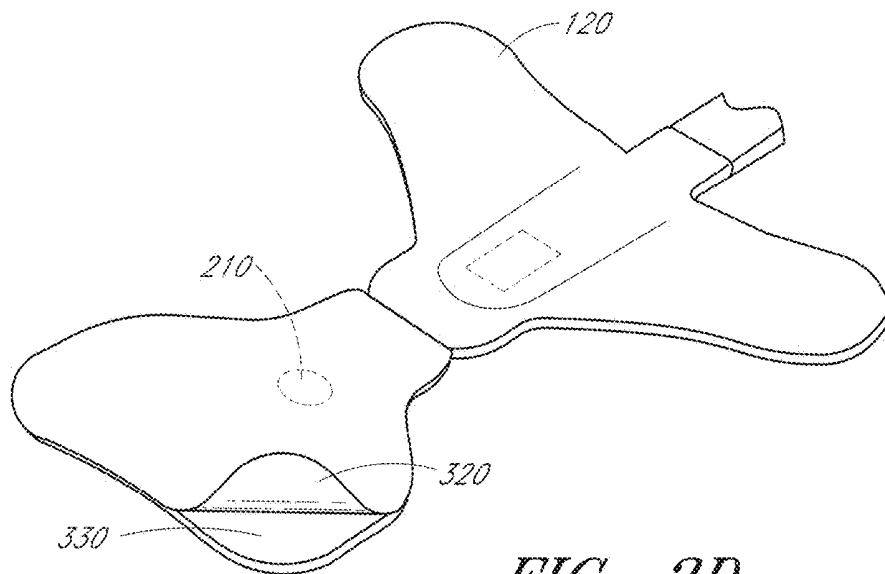

FIG. 3D

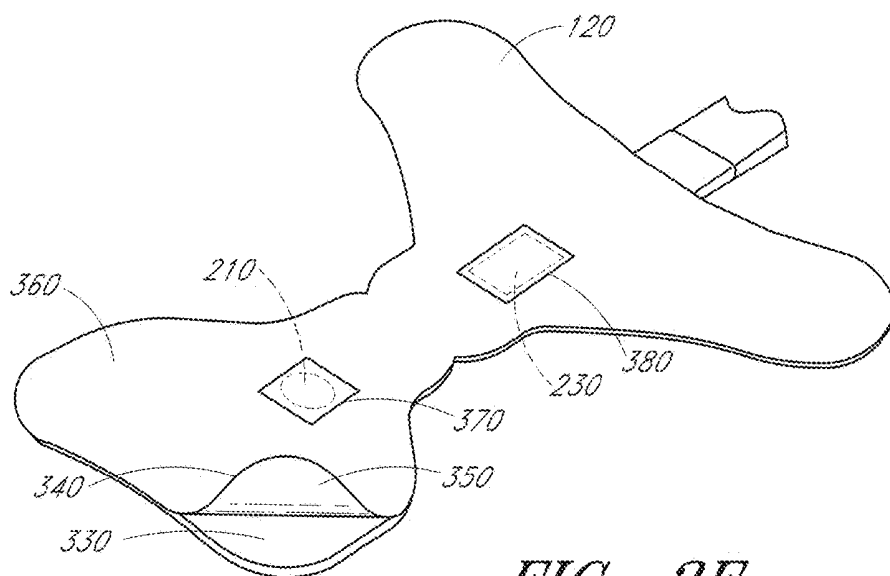

FIG. 3E

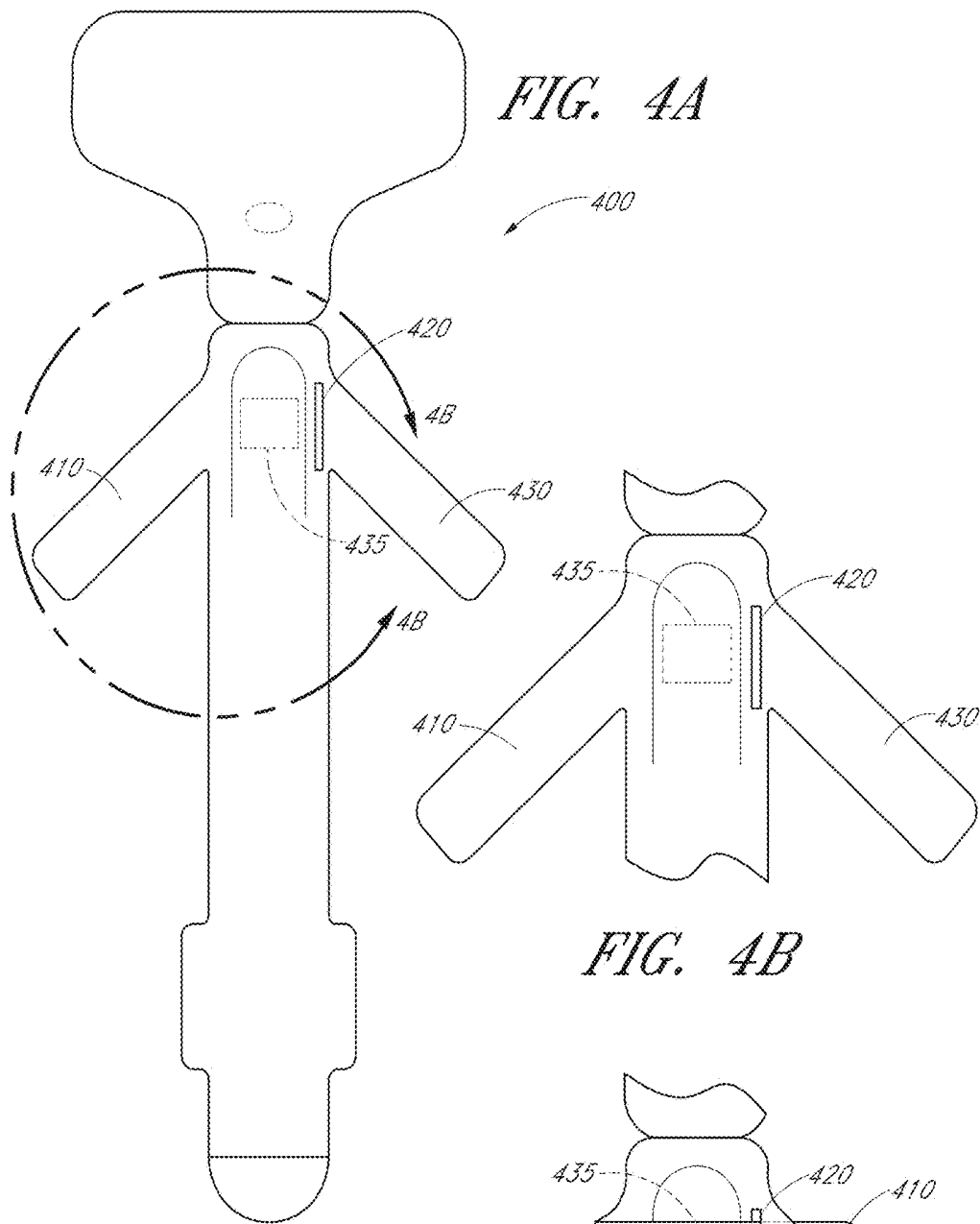

FIG. 4B

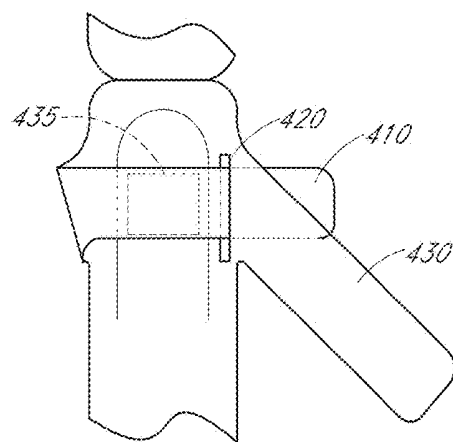

FIG. 4C

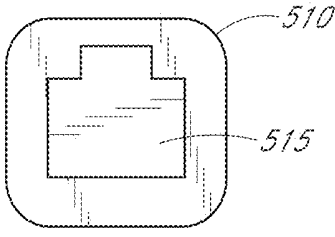

FIG. 5A

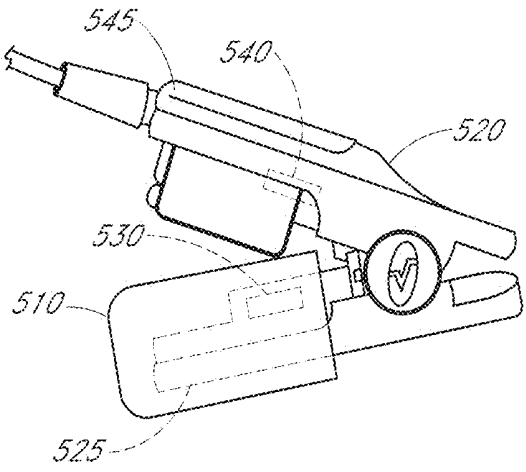

FIG. 5B

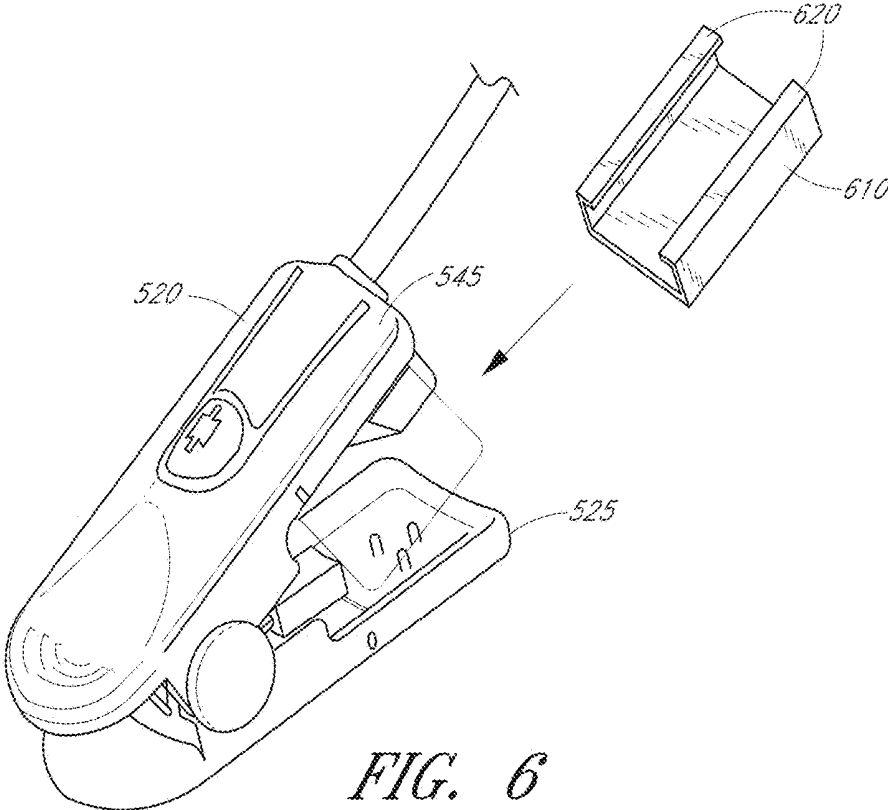

FIG. 6

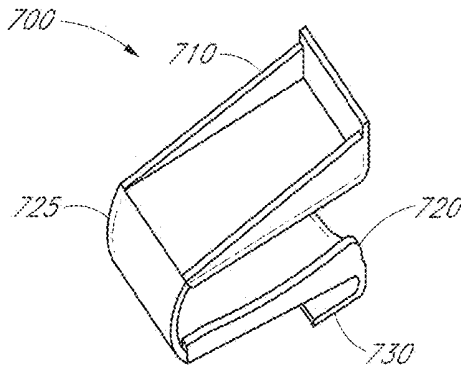

FIG. 7

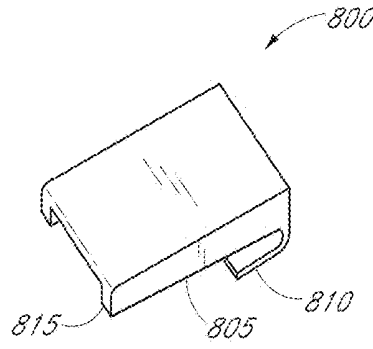

FIG. 8

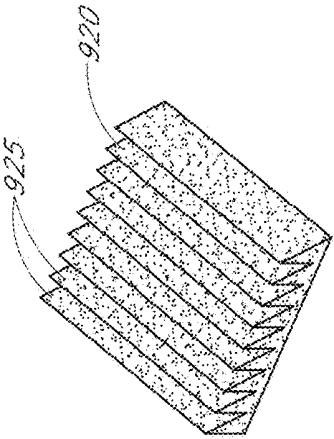

FIG. 9B

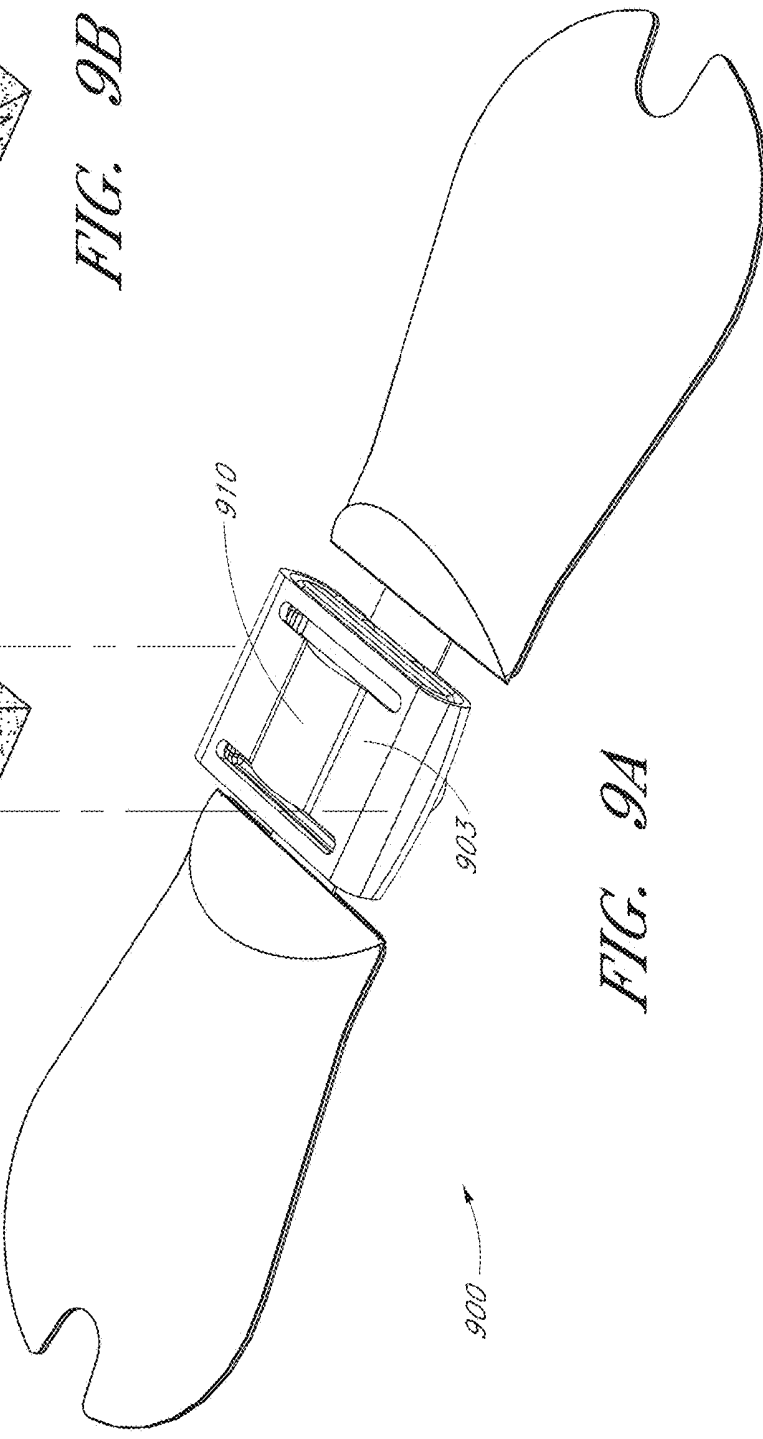
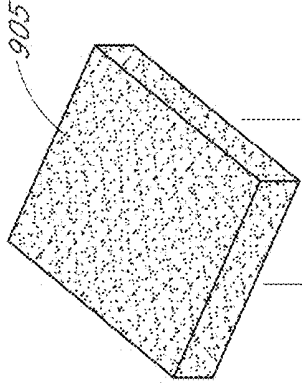
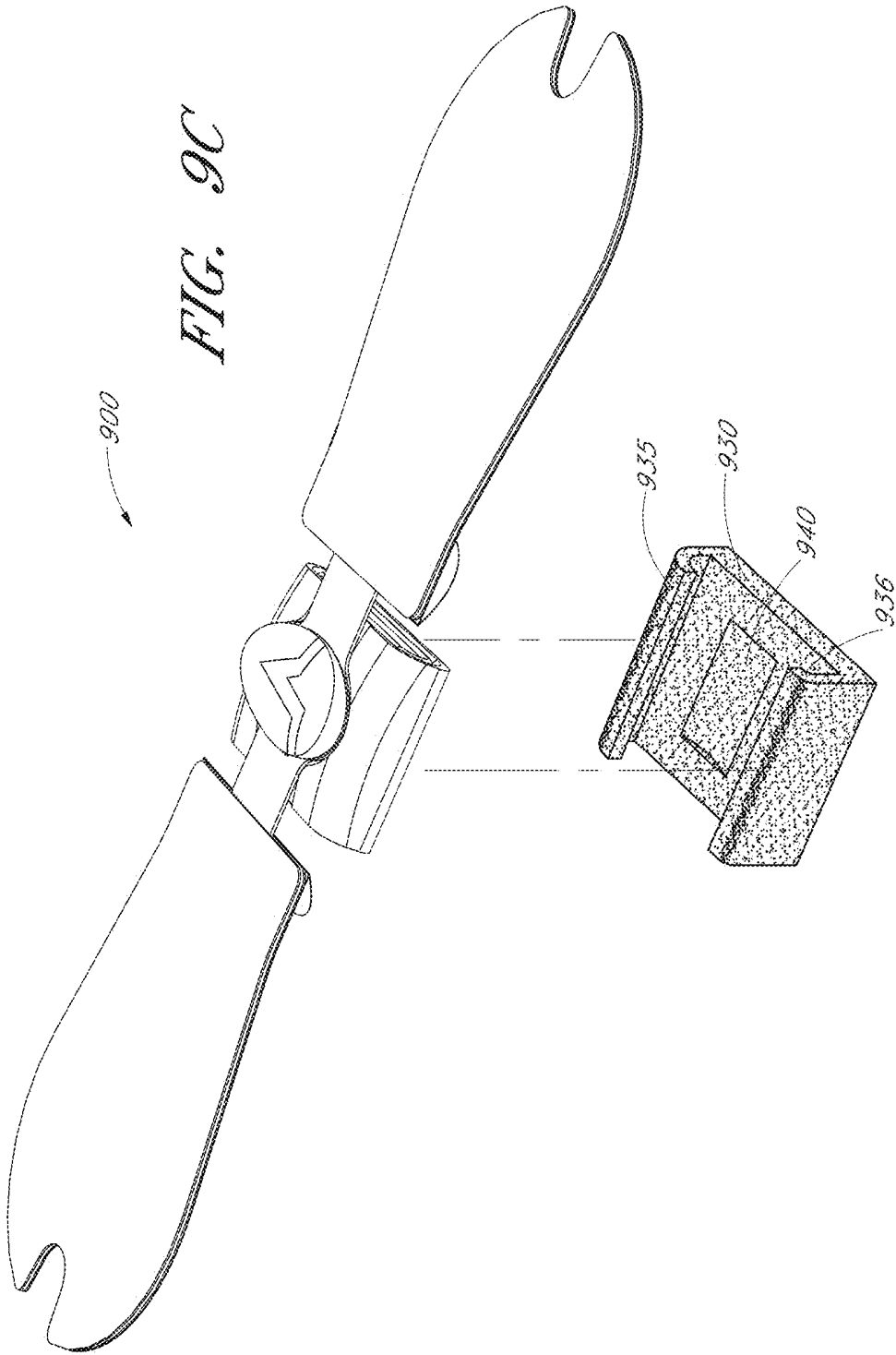
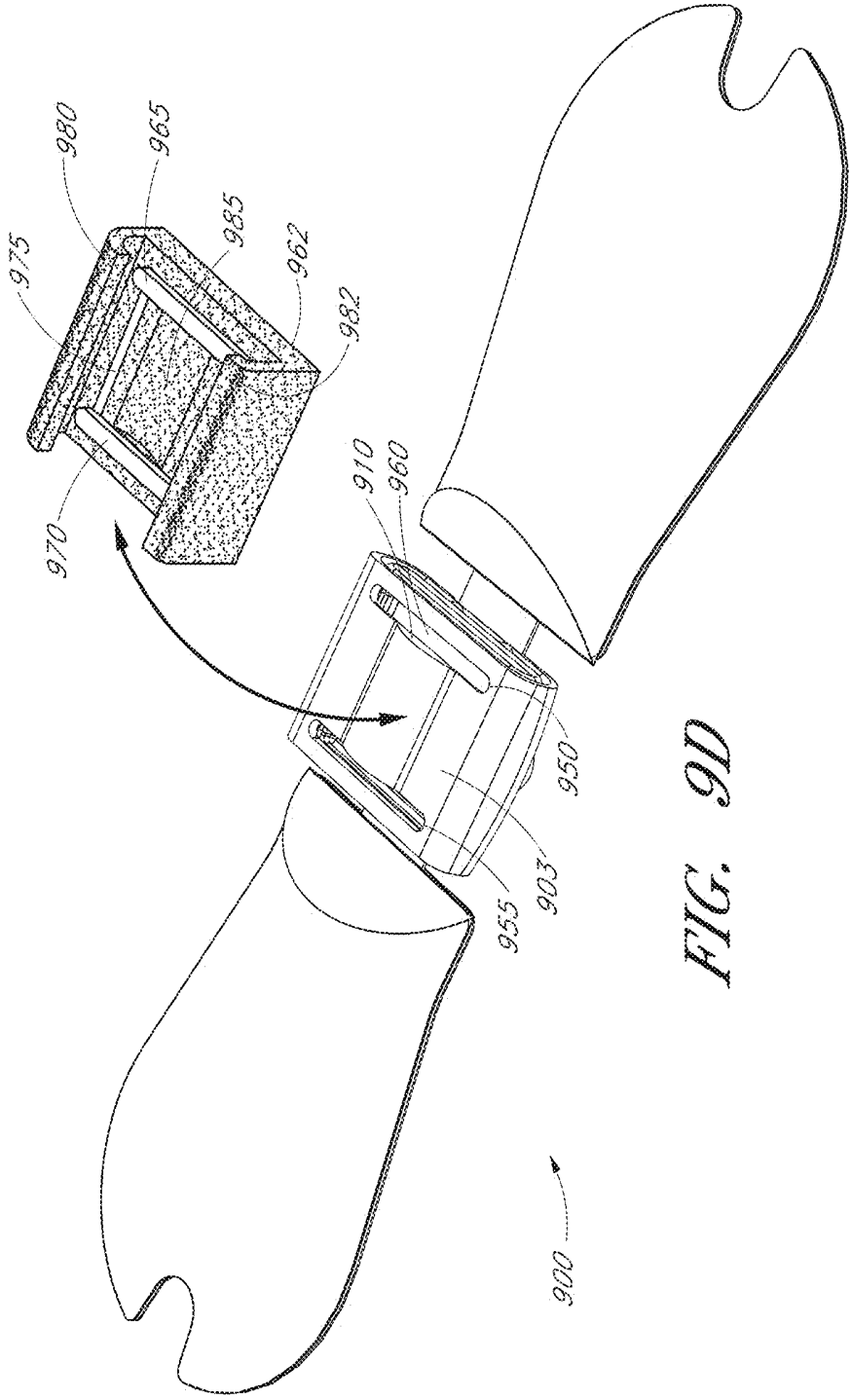

FIG. 9A





NON-INVASIVE PHYSIOLOGICAL SENSOR COVER

CROSS-REFERENCE TO RELATED APPLICATIONS

[0001] The present application is a continuation of U.S. patent application Ser. No. 15/968,393, filed May 1, 2018, titled "NON-INVASIVE PHYSIOLOGICAL SENSOR COVER," which is a continuation of U.S. patent application Ser. No. 15/046,954, filed Feb. 18, 2016, titled "NON-INVASIVE PHYSIOLOGICAL SENSOR COVER," which is a continuation of U.S. patent application Ser. No. 14/512,945, filed Oct. 13, 2014, titled "NON-INVASIVE PHYSIOLOGICAL SENSOR COVER," which is a continuation of U.S. patent application Ser. No. 13/919,692, filed Jun. 17, 2013, titled "NON-INVASIVE PHYSIOLOGICAL SENSOR COVER," which is a continuation of U.S. patent application Ser. No. 12/844,720, filed Jul. 27, 2010, titled "NON-INVASIVE PHYSIOLOGICAL SENSOR COVER," which claims priority benefit under 35 U.S.C. § 119(e) from U.S. Provisional Application No. 61/229,682, filed Jul. 29, 2009, titled "Non-invasive Physiological Sensor Cover." All of the above referenced applications are hereby incorporated by reference herein in their entireties.

FIELD OF THE DISCLOSURE

[0002] The present invention relates to a sensor for measuring oxygen content in the blood, and, in particular, relates to an apparatus and method for preventing sensor activity when the sensor is not in use.

BACKGROUND OF THE DISCLOSURE

[0003] Non-invasive physiological sensors are applied to the body for monitoring or making measurements indicative of a patient's health. One application for a non-invasive physiological sensor is pulse oximetry, which provides a noninvasive procedure for measuring the oxygen status of circulating blood. Oximetry has gained rapid acceptance in a wide variety of medical applications, including surgical wards, intensive care and neonatal units, general wards, and home care and physical training. A pulse oximetry system generally includes a patient monitor, a communications medium such as a cable, and a physiological sensor having light emitters and a detector, such as one or more LEDs and a photodetector. The sensor is attached to a tissue site, such as a finger, toe, ear lobe, nose, hand, foot, or other site having pulsatile blood flow which can be penetrated by light from the emitters. The detector is responsive to the emitted light after attenuation by pulsatile blood flowing in the tissue site. The detector outputs a detector signal to the monitor over the communication medium, which processes the signal to provide a numerical readout of physiological parameters such as oxygen saturation (SpO₂) and pulse rate.

[0004] High fidelity pulse oximeters capable of reading through motion induced noise are disclosed in U.S. Pat. Nos. 6,770,028, 6,658,276, 6,157,850, 6,002,952, 5,769,785, and 5,758,644, which are assigned to Masimo Corporation ("Masimo") and are incorporated by reference herein. Advanced physiological monitoring systems may incorporate pulse oximetry in addition to advanced features for the calculation and display of other blood parameters, such as carboxyhemoglobin (HbCO), methemoglobin (HbMet) and total hemoglobin (Hbt), total Hematocrit (Hct), oxygen

concentrations and glucose concentrations, as a few examples. Advanced physiological monitors and corresponding multiple wavelength optical sensors capable of measuring parameters in addition to SpO₂, such as HbCO, HbMet and Hbt are described in at least U.S. patent application Ser. No. 11/367,013, filed Mar. 1, 2006, titled Multiple Wavelength Sensor Emitters and U.S. patent application Ser. No. 11/366,208, filed Mar. 1, 2006, titled Noninvasive Multi-Parameter Patient Monitor, assigned to Masimo Laboratories, Inc. and incorporated by reference herein. Further, noninvasive blood parameter monitors and optical sensors including Rainbow™ adhesive and reusable sensors and RAD-57™ and Radical-7™ monitors capable of measuring SpO₂, pulse rate, perfusion index (PI), signal quality (SiQ), pulse variability index (PVI), HbCO and HbMet, among other parameters, are also commercially available from Masimo.

SUMMARY OF THE DISCLOSURE

[0005] Optical sensors are widely used across clinical settings, such as operating rooms, emergency rooms, post anesthesia care units, critical care units, outpatient surgery and physiological labs, to name a few. In some situations, such as in operating rooms, emergency rooms or critical care units, sensors can be kept attached to monitors to reduce the setup time needed to begin monitoring a patient. While attached, the sensor can generate false readings by detecting ambient light even though the sensor is not in use. The sensor can also cause the monitor to emit alarms or otherwise make noise due to false readings, which can be distracting to medical personnel.

[0006] As such, a method and apparatus for preventing false readings are desirable. A sensor cover, according to embodiments of the disclosure, prevents or reduces false readings until the sensor is in use.

[0007] Further, in certain embodiments, the sensor cover can prevent damage to the sensor. For example, the sensors cover can protect the emitters and the detector during shipment or prior to use. In certain embodiments, a sensor cover decreases the likelihood of contamination by keeping covered portions of the sensor clean. Sensors in hospitals and other clinical environments are subject to exposure to infectious agents, dust or other foreign matter from depositing on the emitters or detector. The sensor cover can reduce or prevent exposure to these contaminants.

BRIEF DESCRIPTION OF THE DRAWINGS

[0008] FIG. 1 illustrates a sensor cover attached to a sensor of a physiological measurement system according to an embodiment of the disclosure;

[0009] FIGS. 2A-2C are top cover-attached, top cover-detached, and bottom cover-attached perspective views, respectively, of the sensor cover and sensor of FIG. 1;

[0010] FIG. 2D illustrates a first and second sensor covers over the emitters and detector according to an embodiment of the disclosure;

[0011] FIG. 3A illustrates a non-protruding sensor cover according to an embodiment of the disclosure;

[0012] FIG. 3B illustrates a non-protruding sensor cover having an opaque border and a removable opaque center according to an embodiment of the disclosure;

[0013] FIG. 3C illustrates a sensor cover having a clear "window" according to an embodiment of the disclosure;

[0014] FIG. 3D illustrates a sensor cover integrated with an adhesive cover according to an embodiment of the disclosure;

[0015] FIG. 3E illustrates a sensor cover covering an adhesive sensor according to an embodiment of the disclosure;

[0016] FIGS. 4A-4B are a top view and a close up view, respectively, of an integrated sensor cover according to an embodiment of the disclosure;

[0017] FIG. 4C illustrates the sensor cover of FIGS. 4A-4B covering a sensor component;

[0018] FIG. 5A is a front view a sensor cover attachable to a reusable sensor according to an embodiment of the disclosure;

[0019] FIG. 5B illustrates the mating of the sensor cover of FIG. 5A with a sensor;

[0020] FIG. 6 illustrates a sensor cover attachable to a sensor via one or more tabs according to an embodiment of the disclosure;

[0021] FIG. 7 illustrates a sensor cover configured to block both the emitters and the detector according to an embodiment of the disclosure;

[0022] FIG. 8 illustrates a sensor cover attachable to a sensor via an attachment arm according to an embodiment of the disclosure; and

[0023] FIGS. 9A-9D illustrates embodiments of the sensor covers configured for attachment to a bioacoustic sensor, according to embodiments of the disclosure.

DETAILED DESCRIPTION OF THE PREFERRED EMBODIMENT

[0024] A sensor cover according to embodiments of the disclosure is capable of being used with a non-invasive physiological sensor. Certain embodiments of the sensor cover reduce or eliminate false readings from the sensor when the sensor is not in use. Further, embodiments of the sensor cover can prevent damage to the sensor. Additionally, embodiments of the sensor cover prevent contamination of the sensor.

[0025] The tissue site of the illustrated embodiments is a finger and the following description therefore refers specifically to the tissue site as a finger for the purposes of clarity. This is not intended to be limiting and, as described herein, the sensor cover of certain embodiments can be used with sensors attachable to other types of tissue sites, such as a toe, ear lobe, nose, hand, foot, forehead or the like.

[0026] FIG. 1 illustrates an embodiment of a sensor cover attached to a physiological measurement system 100 having a monitor 110 and an optical sensor 120. The optical sensor 120 comprises one or more light emitters and a detector. The optical sensor 120 is configured to plug into a monitor sensor port 112 via a patient cable 130. Monitor keys 114 provide control over operating modes and alarms, to name a few. A display 116 provides readouts of measured parameters, such as oxygen saturation, pulse rate, HbCO, HbMet and Hbt to name a few. Other blood parameters that can be measured to provide important clinical information are fractional oxygen saturation, bilirubin and blood glucose, to name a few.

[0027] In the illustrated embodiment of FIG. 1, the sensor cover 140 protrudes outside the sensor. The cover can be made from an opaque material, such as, for example, plastic, polyester, polypropylene, rubber, vinyl, cling vinyl and/or the like. The sensor cover 140 can obstruct the detector and prevent the detector from detecting light, thereby reducing

or eliminating false readings. For example, the sensor 120 can sometimes be left attached to a monitor 110 to facilitate quick monitoring of a patient, even when not currently in use. The opaque cover 140 can prevent or reduce false readings caused by the emitters or the ambient light, even if the sensor is active, by preventing the sensor from receiving light. In an embodiment, the opaque material can block all wavelengths of light used by a particular sensor. Other embodiments can block different ranges of wavelengths depending on the type of sensor the cover is used for. In an embodiment, the sensor cover 140 is placed over the emitters to prevent the sensor from emitting light receivable by the detector. In an embodiment, both the detector and emitter are covered.

[0028] In some embodiments, the sensor cover 140 can be removed before placement at a measurement site. For example, once a patient arrives, medical personnel can remove the sensor cover 140 and attach the now fully operational sensor 120 to the patient. In some embodiments, the medical personnel can attach the sensor 120 with the cover 140 still in place. The opaque cover prevents measurements from being taken until the sensor 120 is generally secure and the medical personnel are ready to take measurements. For example, movement can generate artifacts for some sensors; therefore waiting until the patient is stable can reduce measurement of inaccurate data. Once the sensor 120 is generally secured to an attachment site, the cover 140 can be removed from the sensor. In some embodiments, the sensor cover 140 can be removed before and/or after placement at a measurement site. The sensor cover 140 can be removed by peeling it off from the sensor or by pulling on the protruding portion.

[0029] As will be appreciated by skilled artisans from the disclosure provided herein, various attachment mechanisms can be used. For example, the sensor cover can be attached with an adhesive. In certain embodiments, a restorable adhesive can be used to facilitate reattachments of the sensor cover. The restorable adhesive layer can be rejuvenated by application of alcohol to the adhesive. The cover can then be reattached to the sensor. This can be useful where the sensor is moved to a new location or tissue site because the cover can prevent the sensor from taking false readings while the sensor is moved. In some embodiments, no adhesive is used on the sensor cover to leave no residue. In some embodiments, the sensor cover can be made from static cling vinyl, plastic film, or other "clingy" material with no adhesive used. In some embodiments, the sensor cover can be attached through static electricity allowing the cover to cling to the sensor without any adhesive and/or allowing the sensor cover to be reapplied. In other configurations, the sensor cover can be attached with Velcro, fasteners, tabs, clips, slots, or the like.

[0030] As will also be appreciated by skilled artisans from the disclosure provided herein, the sensor cover can be detached in various ways. In some embodiments, the sensor cover can be peeled off from the sensor before the sensor is placed at a measurement site. In some embodiments, the sensor can be pulled off from the sensor after placement by pulling on a protruding portion. Depending on the attachment mechanism, the detachment of the sensor cover can expose an adhesive layer or can leave no adhesive residue on the sensor. In some embodiments, the sensor cover can be unclipped or unhooked.

[0031] In certain embodiments, the sensor covers are reusable. For example, the sensor cover can be reused if the sensor is temporarily removed for repositioning or for cleaning. The sensor cover can also be replaced on the sensor when the sensor is no longer in use. In some embodiments, the sensor covers are disposable and are disposed of once removed from the sensor.

[0032] Although disclosed with reference to the sensor of FIG. 1, an artisan will recognize from the disclosure herein a wide variety of oximeter sensors, optical sensors, non-invasive sensors, medical sensors, or the like that may benefit from the sensor cover disclosed herein. In various embodiments, the sensor can be adapted to receive a tissue site other than a finger such as a, toe, ear lobe, nose, hand, foot, neck, or other site having pulsatile blood flow which can be penetrated by light from the emitter. In addition, the sensor cover 140 can be used with a portable monitor and associated sensor components in certain embodiments. Such monitors, including the sensor components, can be integrated into a hand-held device such as a PDA and typically do not include cables or separate monitors. Portable monitors are often used by first responders in emergency situations, in part because of their portability and ease of use. As such, sensor covers 140 which can protect the sensor components according to embodiments herein can be of particular benefit when used with spot-check monitors.

[0033] FIGS. 2A-2C are top cover-attached, top cover-detached, and bottom cover-attached perspective views, respectively, of the sensor cover and sensor of FIG. 1. FIG. 2D illustrates a first 140 and second 240 sensor covers placed over the detector 210 and emitters 230, respectively. FIG. 2A illustrates a view of a side of the sensor placed in contact with a tissue site. In FIG. 2A, the sensor cover 140 attaches to the sensor 120 and covers the detector 210, with a protruding portion 220 extending past the sensor. The sensor cover 140 can be a generally elongated shape made of an opaque material. In an embodiment, one side of the sensor cover can include an adhesive layer over the portion of the cover designed to block the detector 210 while the remainder of the cover can be adhesive free. Thus, the cover 140 does not catch on other objects and cause the cover 140 to be prematurely removed. The cover 140 can be removed by pulling on the protruding portion 220 either before or after the sensor 120 has been placed onto a measurement site. FIG. 2B illustrates the sensor 120 with the sensor cover 140 removed. FIG. 2C illustrates a view of an opposite side of the sensor of FIG. 2A.

[0034] FIG. 3A illustrates a non-protruding sensor cover 310 according to an embodiment of the disclosure. The opaque sensor cover 310 fits within the sensor 120 and blocks a sensor component 210, such as the emitters or the detector. By staying within the sensor edges, the chance of accidental removal of the cover can be reduced. When the sensor 120 is ready for use, the sensor cover 310 can be removed.

[0035] FIG. 3B illustrates a non-protruding sensor cover having an opaque border 314 and a removable opaque center 312. The opaque center 312 can be removed separately from the opaque border 314, leaving an opaque material surrounding the sensor component 210. When the sensor is attached to the patient, the opaque border 314 can minimize light piping, thereby increasing accuracy of the readings. For example, the opaque border 314 can prevent reflected or scattered light that has not passed through tissue from

entering into the detector and/or prevent the detector from picking up light from the emitters that fall around instead of on the detector. In an embodiment, the sensor cover can have adhesive on one both sides. Adhesive on both sides of the sensor cover allows the cover to stick to a patient, further preventing light piping or movement of the sensor. In an embodiment the sensor cover can have a clear window section in addition to or instead of a removable center 312.

[0036] FIG. 3C illustrates a sensor cover 316 having a clear "window" 317 over the sensor component. In an embodiment, the sensor cover can be used to protect the sensor component, provide a new adhesive layer, and/or reduce light piping while allowing the light through the "window." By using a clear window, the sensor cover does not have to be removed when sensor is attached to the patient. In some embodiments, a removable opaque portion can be placed over the window.

[0037] FIG. 3D illustrates a sensor cover integrated with an opaque adhesive cover 320 for the sensor. An adhesive sensor generally has one or more adhesive covers 320 covering one or more adhesive portions 330 of the sensor. In FIG. 3D, the opaque adhesive cover 320 is extended to cover the sensor component 210. The adhesive cover 320 can be peeled off to reveal the adhesive layer 330 and uncover the sensor component 210.

[0038] FIG. 3E illustrates a sensor cover 340 covering an adhesive sensor. In FIG. 3E, the opaque sensor cover 340 has adhesive material on both sides of the sensor cover in order to allow reattachment of a sensor where the original adhesive material 330 has lost its adhesiveness. The sensor cover 340 can be placed on the sensor using a first adhesive layer 350 while the sensor is detached from a patient. An adhesive cover (not shown) protects a second adhesive layer 360 and can be removed before the sensor is placed on the patient. The second adhesive layer allows the sensor to be reattached to the patient. The sensor cover can cover both the detector and emitters of the sensor. The sensor cover 322 can have removable or clear sections 370, 380 over the detector and/or emitters to allow light to pass through.

[0039] FIGS. 4A-4B are a top view and a close up view, respectively, of an integrated sensor cover according to an embodiment of the disclosure. FIG. 4A illustrates an embodiment of the sensor cover where the sensor cover 410 is integrated with the sensor 400. The sensor has a slot 420 positioned near an emitter or a detector. The slot allows an arm 410, 430 to be folded over a sensor component 435, which can be the emitters or the detector, thereby covering it. In certain embodiments, the sensor 400 is an adhesive sensor. The use of a slot allows an adhesive arm 410 to be used as a sensor cover without having to remove the arm's adhesive cover. Once a patient is available, the adhesive arm 410 can be removed from the slot, the adhesive cover can be removed, and the adhesive arms 410, 430 used to secure the adhesive sensor to the patient. FIG. 4B illustrates a close up view of the slot 420 and sensor cover 410 of FIG. 4A. FIG. 4C illustrates the sensor cover 410 folded over the sensor component 435 with the end of the sensor cover inserted into the slot. A portion of the sensor cover extends into the slot and to the back side of the sensor. The slot keeps the sensor cover 410 generally secure against the sensor component 435.

[0040] FIG. 5A is a front view a sensor cover 510 attachable to a reusable sensor according to an embodiment of the disclosure. The sensor cover 510 includes a recess 515 into

which a sensor housing can be inserted. The sensor housing generally fits closely in the recess 515. Friction between the inner surfaces of the sensor cover 510 and the sensor housing generally secures the housing with the sensor cover 510. FIG. 5B illustrates the mating of the sensor cover 510 of FIG. 5A with a sensor 520. In the illustrated embodiment, the sensor 520 is a reusable clip-style sensor. The sensor cover 510 fits over a lower sensor housing 525. The sensor housings 525, 545 can contain sensor components 530, 540, such as the emitters or the detector. In certain embodiments, the sensor component 530 is a detector and the sensor cover 510 prevents the detector from receiving light. The sensor cover 510 can be removed when the sensor 520 is in use and reattached once the sensor 520 is not in use.

[0041] FIG. 6 illustrates a sensor cover 610 attachable to a sensor 520 via one or more tabs or attachment arms 620 according to an embodiment of the disclosure. The tabs 620 fit over the sides of an upper housing 545 of the sensor and generally secure the sensor cover 610 against the upper housing 545. The sensor cover 610 covers the sensor component, such as the emitters or the detector, located in the upper housing 545.

[0042] FIG. 7 illustrates an embodiment of the sensor cover 700 configured to block both the emitters and the detector. An upper arm 710 secures against an upper housing of a sensor. A lower arm 720 secures against a lower housing of a sensor. The upper 710 and lower 720 arms are connected by a hinge portion 725. The arms 710, 720 can be attached via a press fit. The lower arm 720 can also include an attachment arm 730 to better secure the sensor cover 700 against the lower housing of the sensor.

[0043] FIG. 8 illustrates an embodiment of the sensor cover 800 attachable to a sensor housing via an attachment arm 810. The attachment arm 810 is configured to secure the sensor cover 800 in place when applied to the sensor. Upon application to a sensor, the front portion of the sensor housing may occupy the space defined by the attachment arm 810 and the underside of the lower portion 805 of the sensor cover 800. The attachment arm 810 helps to releasably secure the sensor, via a friction fit, for example. One or more other features, such as the lip 815 disposed on the side of the sensor cover proximal to the sensor can be included to further secure the sensor cover 800 in the sensor. Upon insertion of the sensor cover 800 into the sensor, the sides of the sensor housing abut the lip 815. Accordingly, the lip 815 can help ensure that the sensor cover 800 is positioned appropriately deep within the sensor.

[0044] Although the above embodiments have been described with respect to an opaque material intended to optically insulate the optical sensor, as will be appreciated by skilled artisans from the disclosure provided herein, sensor covers made of different insulative materials can be used as appropriate for different types of sensors. For example, sonically insulative materials, such as foam, rubber, cotton, and/or other sound deadening materials can be used to cover sensors that employ sound, such as a bioacoustic or ultrasound sensor. In some embodiments, electrically insulative materials, such as rubber, polyethylene, silicone and/or other insulators can be used to cover sensors that employ electrical signals, such as bioimpedance sensors. In some embodiments, mechanically insulative materials, such as hard plastic, metal, rubber, silicone, and/or other rigid or dampening materials can be used to cover mechanical sensors to prevent sensor actuation. In some

embodiments, chemically insulative material, such as plastic, metal, polyethylene or the like can be used to cover chemical sensors and prevent their exposure to the environment.

[0045] FIGS. 9A-9D illustrate embodiments of sensor covers for a bioacoustic sensor. FIG. 9A illustrates one embodiment of a bioacoustic sensor. The bioacoustic sensor 900 is configured for placement against a patient's skin. The contact surface 903 of the sensor 900 is placed against the skin. The bioacoustic sensor picks up sound waves from the patient's body and converts them into electrical signals for transmission to a monitoring device. In one embodiment, the bioacoustic sensor can use a piezoelectric transducer as the sensing element to detect sound waves. In FIG. 9A a sensor cover 905 made of a sound-deadening material, such as foam, rubber, and/or cotton, is attached to the contact surface to prevent sound waves from being detected by the bioacoustic sensor 900. The sound-deadening material can be attached by adhesive, tabs, clips, friction fit, and/or other connection mechanism. In FIG. 9A, the bioacoustic sensor has a bump 910 on the contact surface 903 positioned to apply pressure to the sensing element so as to bias the sensing element in tension and improve the receptivity of the sensing element to sound waves. Where such a bump 910 exists on the contact surface 903 of the sensor, embodiments of sensor cover 905 can be provided with a corresponding recess.

[0046] FIG. 9B illustrates an embodiment of the sensor cover 920 made of shaped sound-deadening material to increase the surface area available to absorb sound. In one embodiment, a plurality of wedge shaped protrusions 925 is formed on the surface of the sensor cover 920. In other embodiments, different shaped protrusions can be used, such as waveform, pyramid, egg crate, and/or other shapes to increase the surface area.

[0047] FIG. 9C illustrates a bioacoustic sensor cover having one or more attachment arms according to an embodiment of the disclosure. An attachment arm 935 is configured to releasably secure the sensor cover 930 when applied to the sensor via a friction fit, for example. A second attachment arm 936 can be provided to further secure the sensor cover 930 to the sensor 900. A recess 940 can also be formed on the interior surface of the sensor cover 930 in order to conform to protrusions on the contact surface of the sensor 900. Where the contact surface of the sensor 900 is flat, the interior surface can also be flat.

[0048] FIG. 9D illustrates a bioacoustic sensor having conductive leads according to an embodiment of the disclosure. In FIG. 9D, the illustrated bioacoustic sensor 900 has one or more apertures 950, 955 exposing the sensing element 960 to the contact surface 903. In one embodiment, the sensor cover 962 prevents the bioacoustic sensor from taking readings by creating an electrical short in the sensor. One or more conductive leads or wires 965, 970 configured to fit into the apertures 950, 955 in the sensor housing are disposed on the sensor cover 962. The conductive leads 965, 970 abut the negative and positive electrical poles of the sensing element 960. The conductive leads can be formed of copper or other conductive material. In one embodiment, the conductive leads 965, 970 can abut internal wiring that connects to the negative and positive electrical poles, such that a direct connection is not required. The conductive leads 965, 970 are joined by a connector lead or wire 975 to generate a short circuit in the sensor 900. In an embodiment,

the conductive leads **965, 970** and connector lead **975** are a single connected structure. In an embodiment, the sensor cover **962** further comprises one or more attachment arms **980, 982** for releasably securing the sensor cover **962** to the sensor **900**. In an embodiment, the sensor cover **962** further comprises a recess **985** to conform against a protrusion **910** on the contact surface **903** of the sensor. In one embodiment, the sensor cover **962** is formed out of a sound deadening material, such as foam or rubber. In one embodiment, the sensor cover **962** is made of hard plastic or other types of plastic materials.

[0049] Conditional language used herein, such as, among others, “can,” “could,” “might,” “may,” “e.g.,” and the like, unless specifically stated otherwise, or otherwise understood within the context as used, is generally intended to convey that certain embodiments include, while other embodiments do not include, certain features, elements and/or states. Thus, such conditional language is not generally intended to imply that features, elements and/or states are in any way required for one or more embodiments or that one or more embodiments necessarily include logic for deciding, with or without author input or prompting, whether these features, elements and/or states are included or are to be performed in any particular embodiment.

[0050] Various sensor covers have been disclosed in detail in connection with various embodiments. These embodiments are disclosed by way of examples only and are not to limit the scope of the claims that follow. One of ordinary skill in the art will appreciate the many variations, modifications and combinations. For example, in various embodiments, adhesive, snap-fit, friction-fit, clips, tabs, and other attachment mechanisms can be employed. In addition, in various embodiments the sensor covers are used with a sensor that can measure any type of physiological parameter. In various embodiments, the sensor covers can be for any type of medical device or sensor. In various embodiments, adhesive can be placed on both sides of the sensor cover to aid in the reattachment of sensors where the sensor adhesive has grown weak. In various embodiments, sensors covers can be made in whole or in part of materials such as foam, polyester, polypropylene, rubber, vinyl, cling vinyl, urethane rubber plastic or other plastic materials, cloth, metal, combinations of the same or the like.

1. (canceled)

2. A partially opaque sensor cover for use with a pulse oximeter sensor, the partially opaque sensor cover comprising:

a partially opaque portion attachable to the sensor and configured to block optical readings by the sensor; and
a tab portion that protrudes from the sensor to facilitate removal of the partially opaque sensor cover,

wherein the sensor comprises:

a light source configured to emit light from one or more emitters of the sensor; and

a detector configured to receive at least a portion of the light emitted by the one or more emitters after the light has passed through a tissue site, and

wherein the partially opaque portion at least partially prevents the detector from receiving light during sensor activation.

3. The partially opaque sensor cover of claim 2, wherein the tab portion that protrudes from the sensor comprises a rectangular portion that extends past the sensor.

4. The partially opaque sensor cover of claim 2, wherein the partially opaque sensor cover is removably adhereable to the sensor.

5. The partially opaque sensor cover of claim 2, wherein the partially opaque sensor cover is configured to block the light from the one or more emitters from being received by the detector.

6. The partially opaque sensor cover of claim 2, wherein the partially opaque portion is attachable over at least one of the detector or the one or more emitters.

7. The partially opaque sensor cover of claim 2, wherein the partially opaque portion is configured to block ambient light from a surrounding area.

8. The partially opaque sensor cover of claim 2, wherein: the sensor includes a window formed on a surface of the sensor and aligned with the one or more emitters and the detector, and

the partially opaque portion covers the window.

9. A method of blocking readings by a pulse oximeter sensor, the method comprising:

providing a removable sensor cover comprising:

a first portion attachable to the sensor, the first portion covering optical components of the sensor such that the first portion reduces the likelihood that the sensor will generate a false measurement when the sensor is active and not proximate a physiological measurement site; and

a tab portion that protrudes from the sensor to facilitate removal of the removable sensor cover; and
attaching the removable sensor cover to the sensor,

wherein the optical components of the sensor comprise:

a light source configured to emit light from one or more emitters of the sensor; and

a detector configured to receive at least a portion of the light emitted by the one or more emitters after the light has passed through a tissue site.

10. The method of claim 9, wherein the tab portion that protrudes from the sensor comprises a rectangular portion that extends past the sensor.

11. The method of claim 9, wherein the first portion is removably adhereable to the sensor.

12. The method of claim 9, further comprising:

activating the light source of the sensor to emit light from the one or more emitters of the sensor; and

at least partially blocking, with the removable sensor cover, the light from the one or more emitters from being received by the detector of the sensor.

13. The method of claim 9, wherein the first portion is attachable over both of the detector and the emitters.

14. The method of claim 9, wherein the first portion is configured to block ambient light from a surrounding area.

15. The method of claim 9, wherein:

the sensor includes a window formed on a surface of the sensor and aligned with the optical components of the sensor to allow light to reach the optical components of the sensor, and

the first portion covers the window and the optical components of the sensor.

16. The method of claim 9, wherein the removable sensor cover is partially opaque.

17. A sensor cover for use with a pulse oximeter sensor, the sensor cover comprising:

a rectangular planar portion that extends beyond at least one border of a pulse oximeter sensor to provide a tab; and

an additional portion configured to cover optical components of the sensor when adhesively coupled to the sensor,

wherein the sensor cover is configured to reduce a likelihood of a false measurement by at least partially preventing light from reaching a detector of the optical components when the sensor is active but not proximate a measurement site.

18. The sensor cover of claim 17, wherein the additional portion is further configured to cover a window of the sensor that is aligned with the optical components of the sensor.

19. The sensor cover of claim 18, wherein the optical components of the sensor include at least:

one or more emitters; and

the detector configured to receive at least a portion of light emitted by the one or more emitters after the light has passed through a tissue site.

20. The sensor cover of claim 19, wherein the tab is configured to enable removal of the sensor cover from the sensor.

21. The sensor cover of claim 20, wherein the rectangular planar portion and the additional portion together comprise a single integral component.

22. The sensor cover of claim 21, wherein the sensor cover is partially opaque.

23. The sensor cover of claim 17, wherein the light comprises ambient light.

24. The sensor cover of claim 17, wherein the light comprises light emitted by one or more emitters of the optical components.

* * * * *

专利名称(译)	无创生理传感器盖		
公开(公告)号	US20190029580A1	公开(公告)日	2019-01-31
申请号	US16/149533	申请日	2018-10-02
[标]申请(专利权)人(译)	梅西莫股份有限公司		
申请(专利权)人(译)	Masimo公司		
当前申请(专利权)人(译)	Masimo公司		
[标]发明人	KIANI ABRAHAM MAZDA KIANI MASSI JOE E		
发明人	KIANI, ABRAHAM MAZDA KIANI, MASSI JOE E.		
IPC分类号	A61B5/1455 A61B5/024 A61B5/00 A61B5/145		
CPC分类号	A61B5/14552 A61B5/02416 A61B5/6826 A61B5/02427 A61B5/6819 A61B5/6829 A61B5/14532 A61B5/6816 A61B5/6838 A61B5/6832 A61B5/14546 A61B5/68335		
优先权	61/229682 2009-07-29 US		
其他公开文献	US10188331		
外部链接	Espacenet USPTO		

摘要(译)

根据本公开的实施例的传感器盖能够与非侵入性生理传感器一起使用，例如脉搏血氧测量传感器。当传感器未使用时，传感器盖的某些实施例减少或消除来自传感器的错误读数，例如，当脉冲血氧计传感器激活但未使用时，通过阻挡脉冲血氧计传感器的光检测部件。此外，传感器盖的实施例可以防止对传感器的损坏。另外，传感器盖的实施例防止传感器的污染。

