



US 20200015723A1

(19) **United States**

(12) **Patent Application Publication**
EISEN et al.

(10) **Pub. No.: US 2020/0015723 A1**

(43) **Pub. Date: Jan. 16, 2020**

(54) **WRIST-SENSOR PULSE OXIMETRY DEVICE AND METHOD**

(71) Applicant: **Oxitone Medical Ltd., Kfar Saba (IL)**

(72) Inventors: **LEON EISEN, Kfar Saba (IL); Uzi Ben-Zion, Kfar Saba (IL); Koby Refael Gil, Kfar Saba (IL); Ofer Harpak, Kfar Saba (IL); Avi Shaham, Kfar Saba (IL)**

(73) Assignee: **Oxitone Medical Ltd., Kfar Saba (IL)**

(21) Appl. No.: **16/468,045**

(22) PCT Filed: **Dec. 15, 2017**

(86) PCT No.: **PCT/IB17/58022**

§ 371 (c)(1),

(2) Date: **Jun. 10, 2019**

Related U.S. Application Data

(60) Provisional application No. 62/438,501, filed on Dec. 23, 2016.

Publication Classification

(51) **Int. Cl.**
A61B 5/1455 (2006.01)
A61B 5/00 (2006.01)

(52) **U.S. Cl.**
CPC *A61B 5/14552* (2013.01); *A61B 5/681* (2013.01); *A61B 5/02427* (2013.01); *A61B 2562/185* (2013.01); *A61B 5/6831* (2013.01)

(57) **ABSTRACT**

A pulse oximetry device is provided that fixates generally around a user's wrist. The device may include one or more mechanical features that fix the device at, for example, a distal end of a wearer's ulna bone. The device may include one or more projections formed from a suitable material (e.g., elastomer such as silicon) that cause the device to fit snugly against the wearer's wrist and remain in place even when the wearer is moving, thus reducing motion artifacts in signals detected by the device. The device may include one or more mechanical features or fins that reduce ambient or stray light in the measurement area. The device may include one or more detectors, and one or more light sources, each having a different axis resulting from the manner in which each is angled toward a virtual center point of the distal end of a wearer's ulna bone.

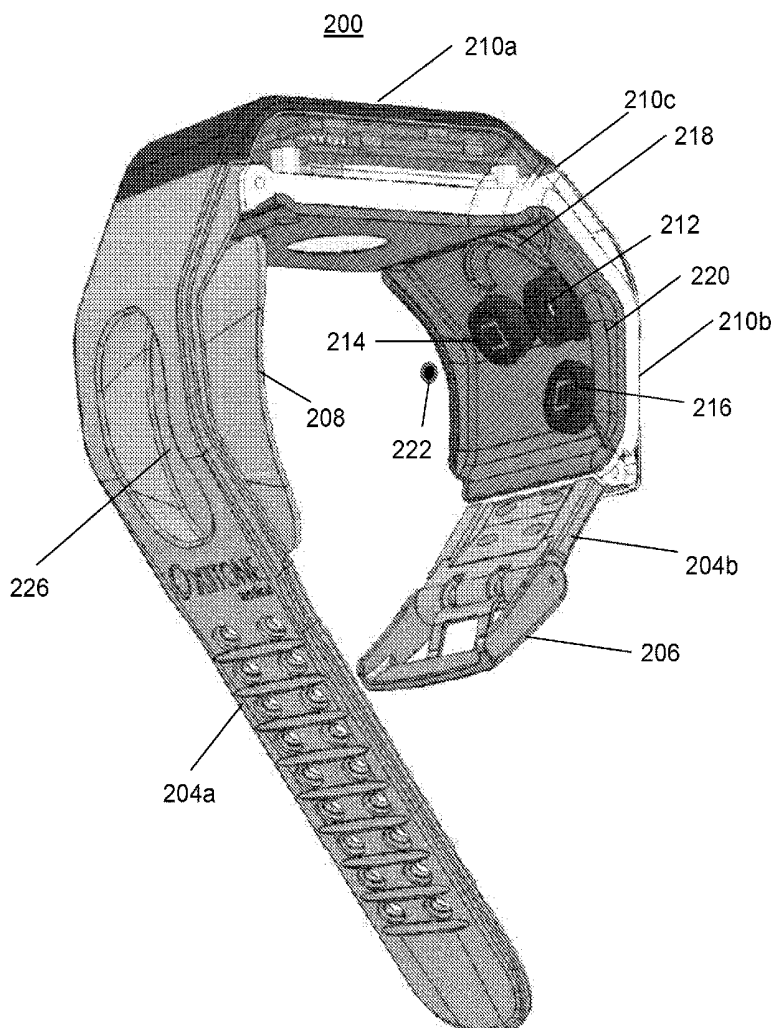

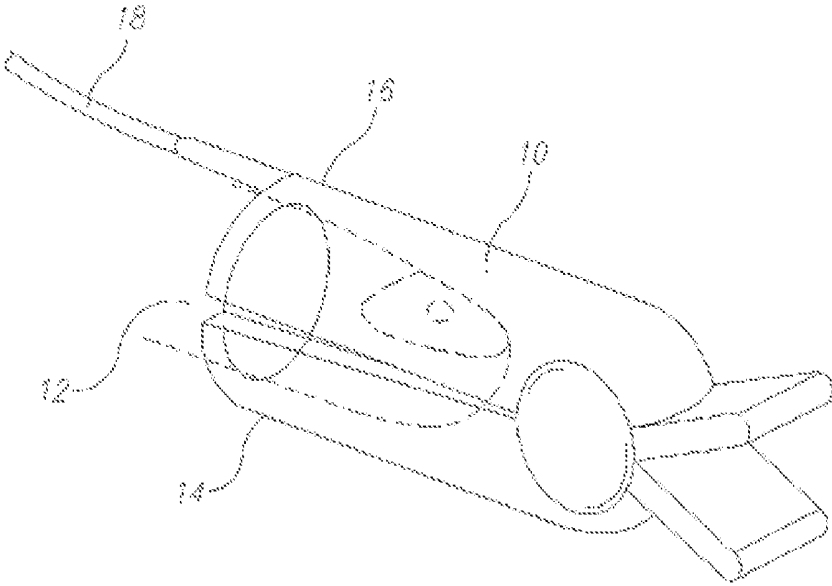

FIG. 1
PRIOR ART

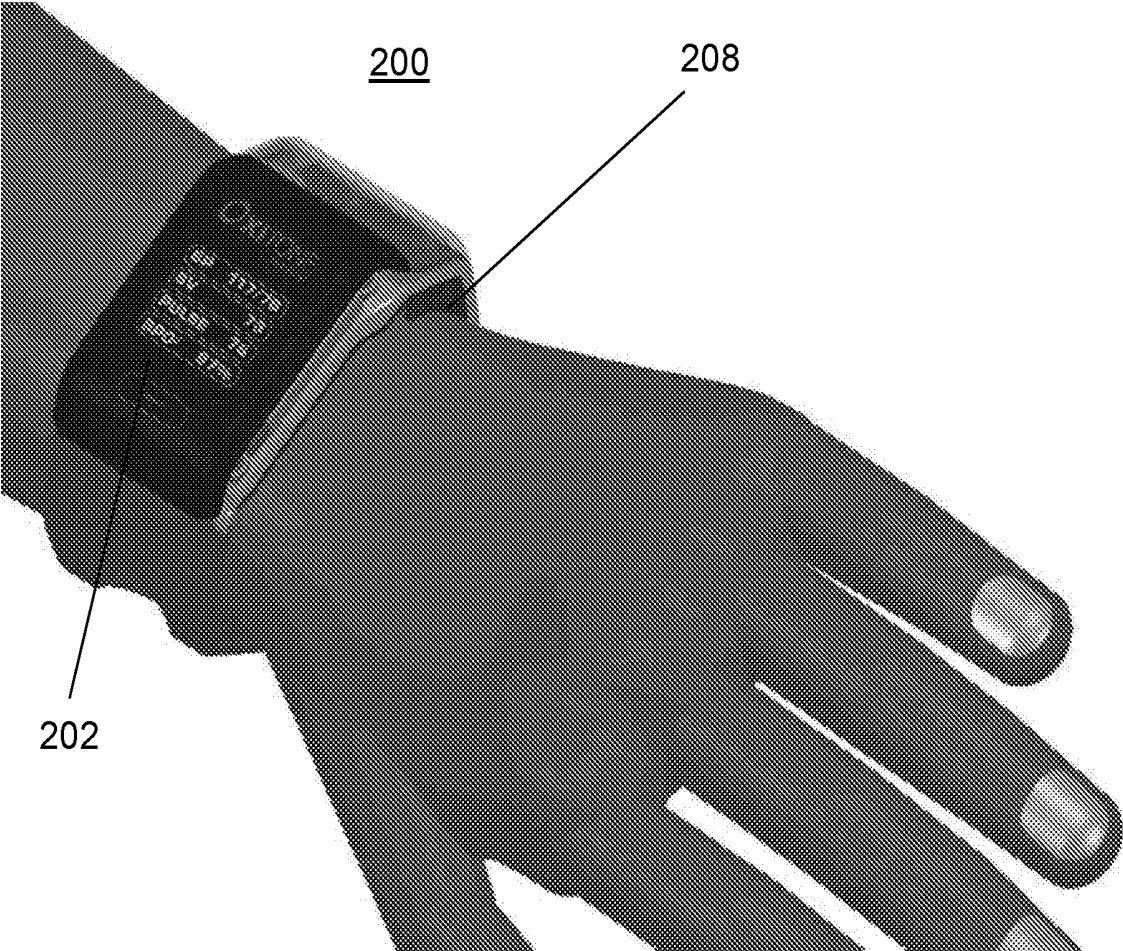

FIG. 2

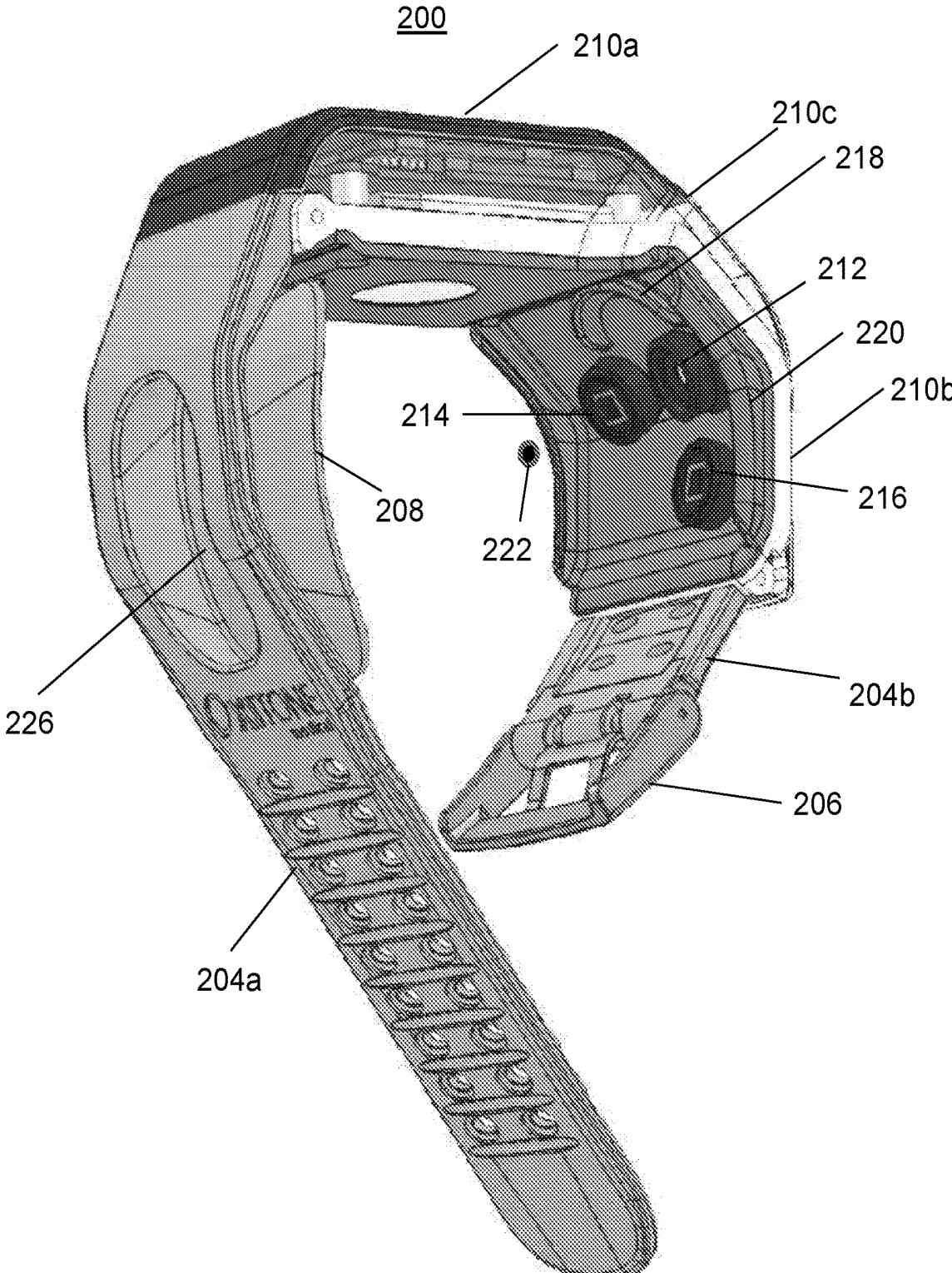
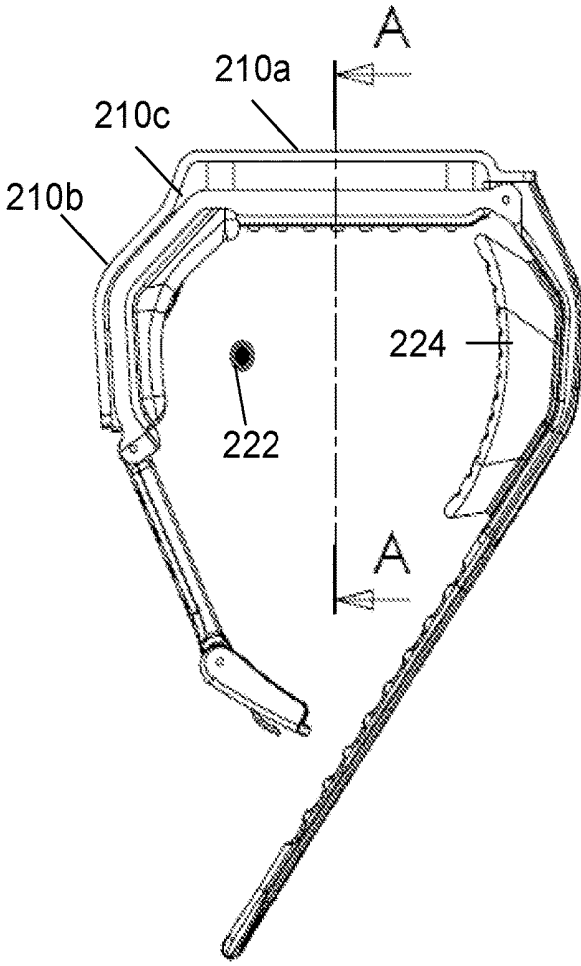
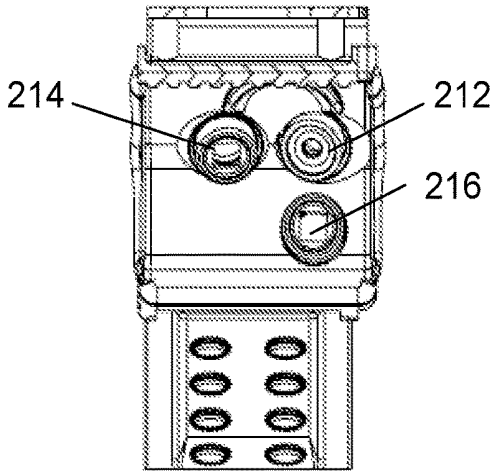

FIG. 3



SCALE 1 : 1

FIG. 4A



SECTION A-A
SCALE 1 : 1

FIG. 4B

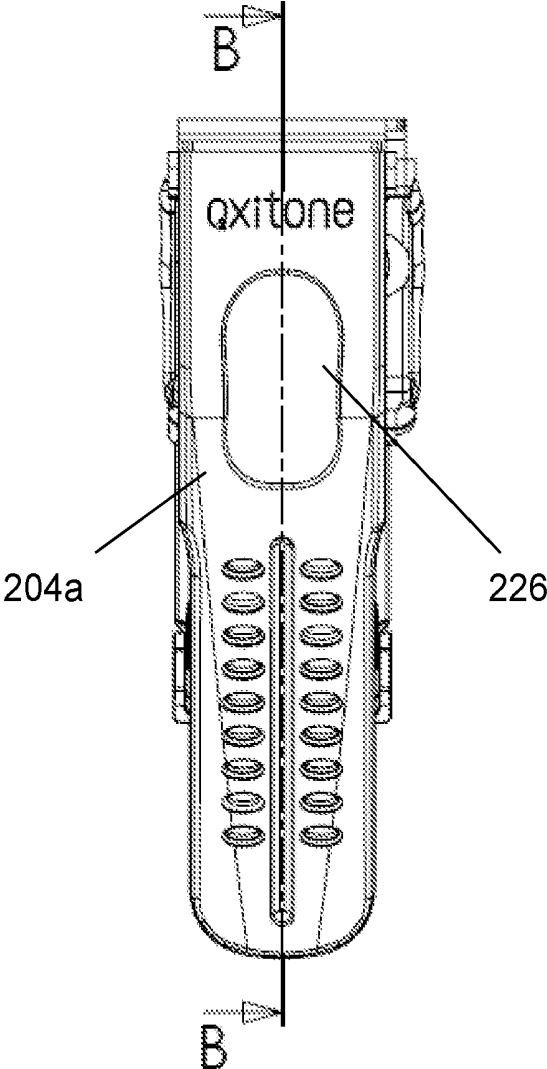
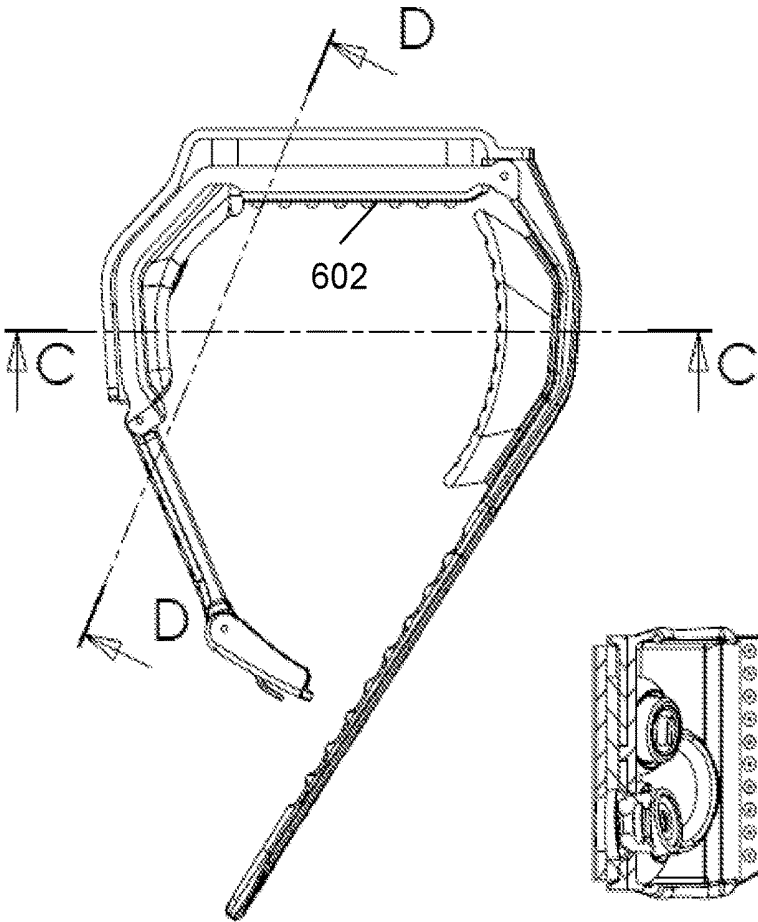
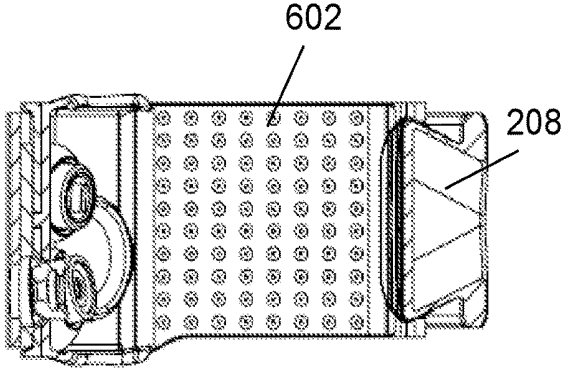

FIG. 5



SCALE 1 : 1

FIG. 6A



SECTION C-C
SCALE 1 : 1

FIG. 6B

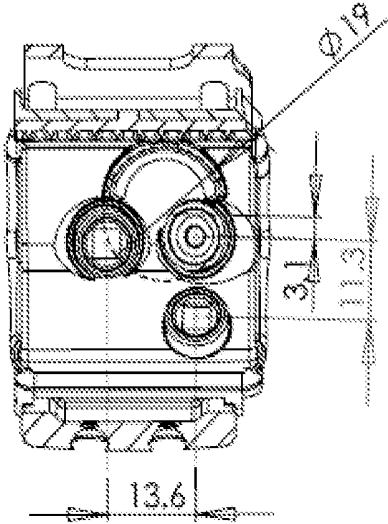

SECTION D-D
SCALE 1 : 1

FIG. 6C

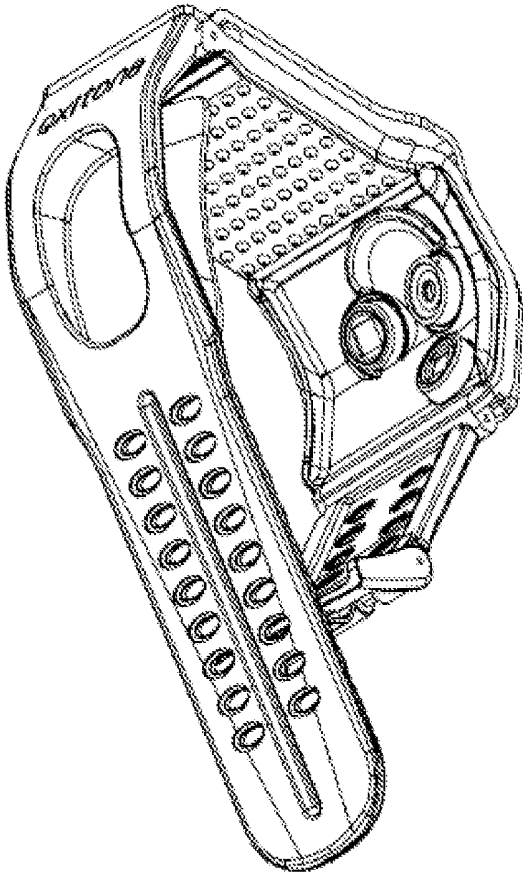

FIG. 7

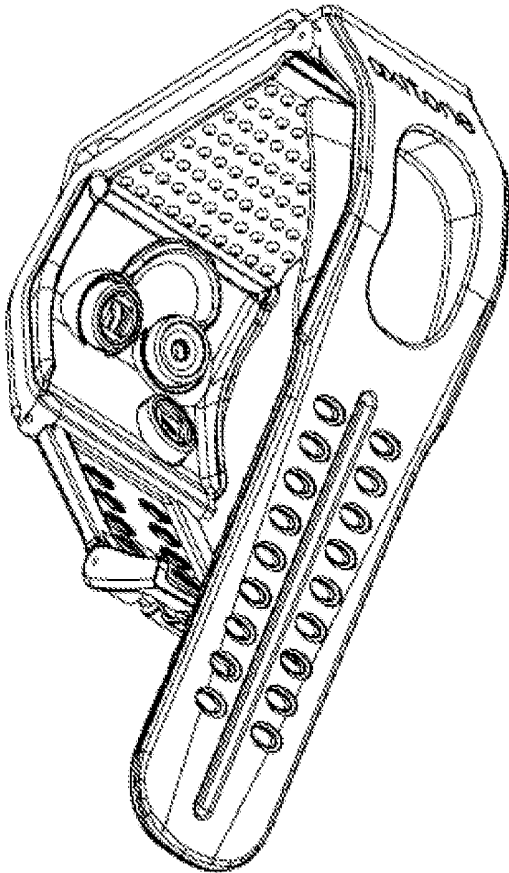

FIG. 8

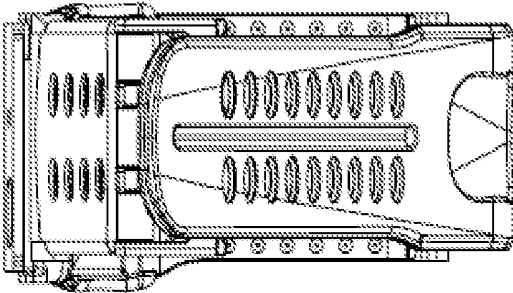

FIG. 9

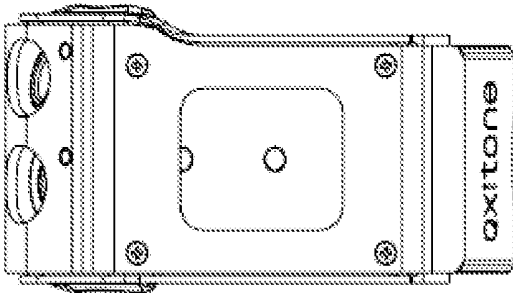

FIG. 10

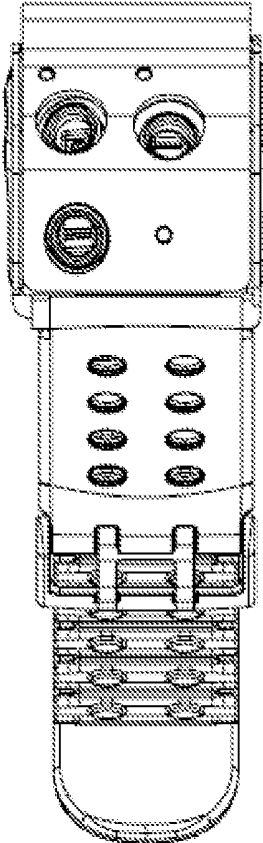

FIG. 11

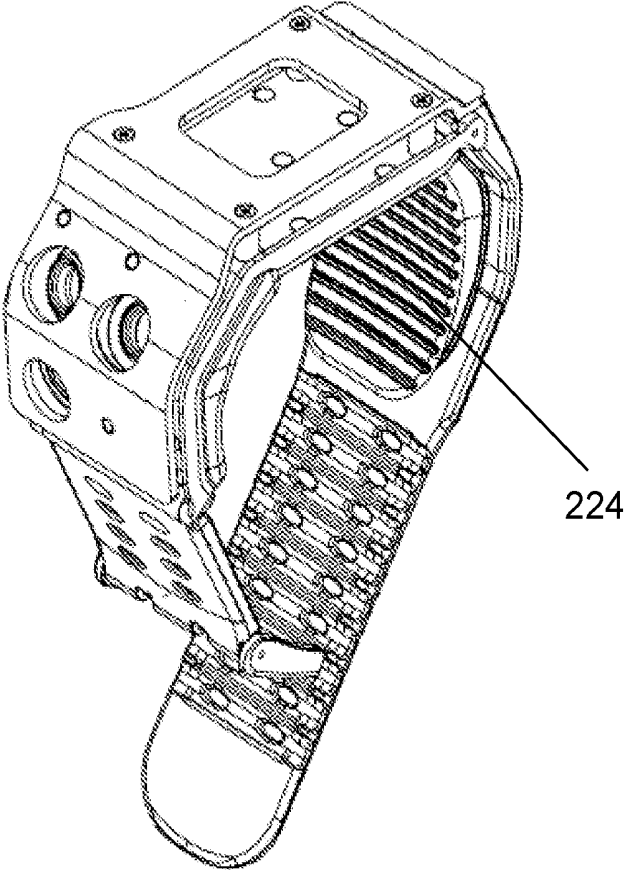

FIG. 12

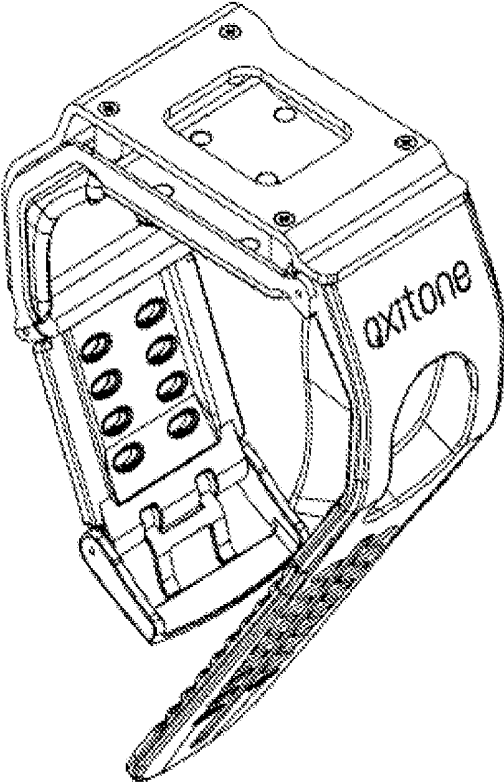

FIG. 13

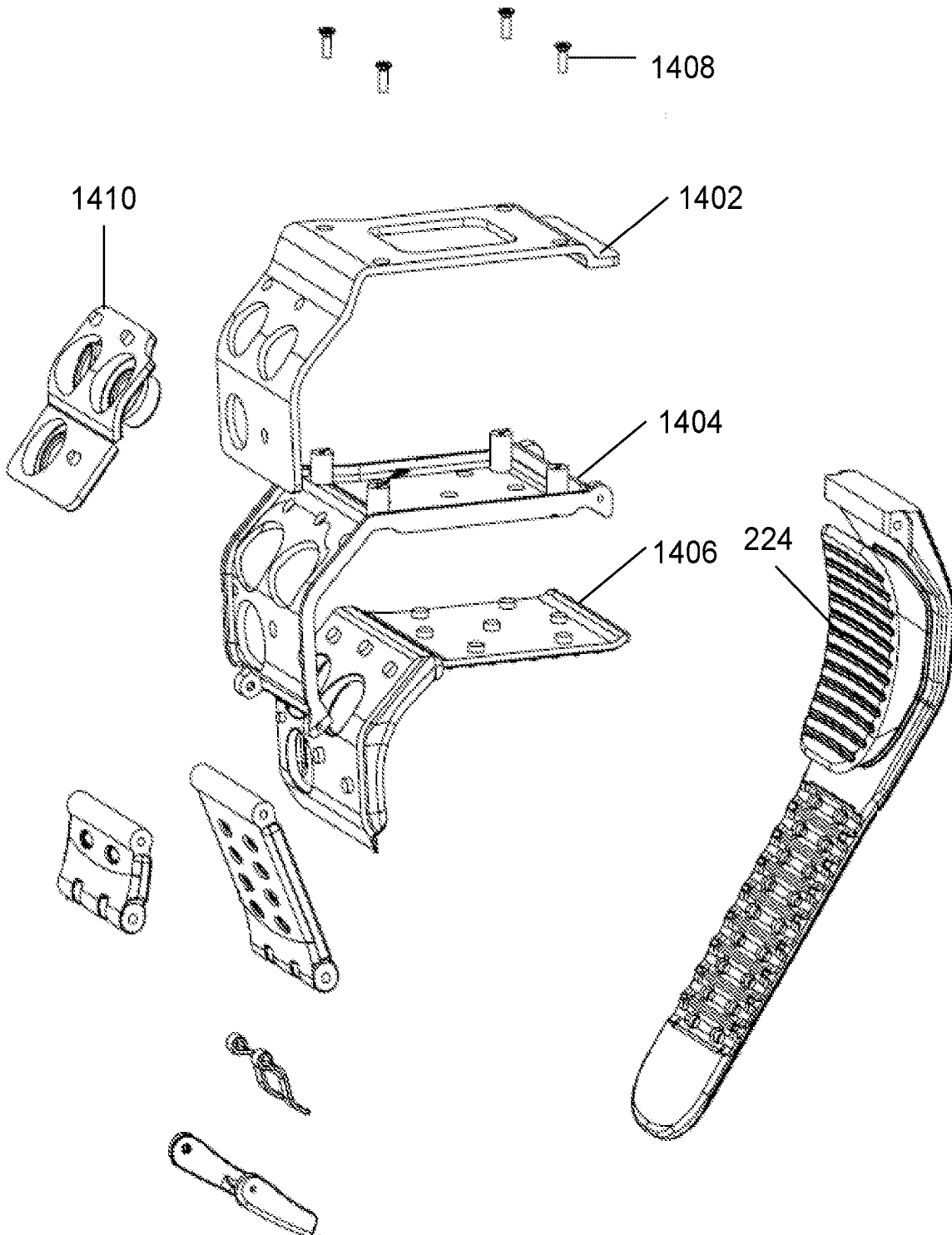

FIG. 14

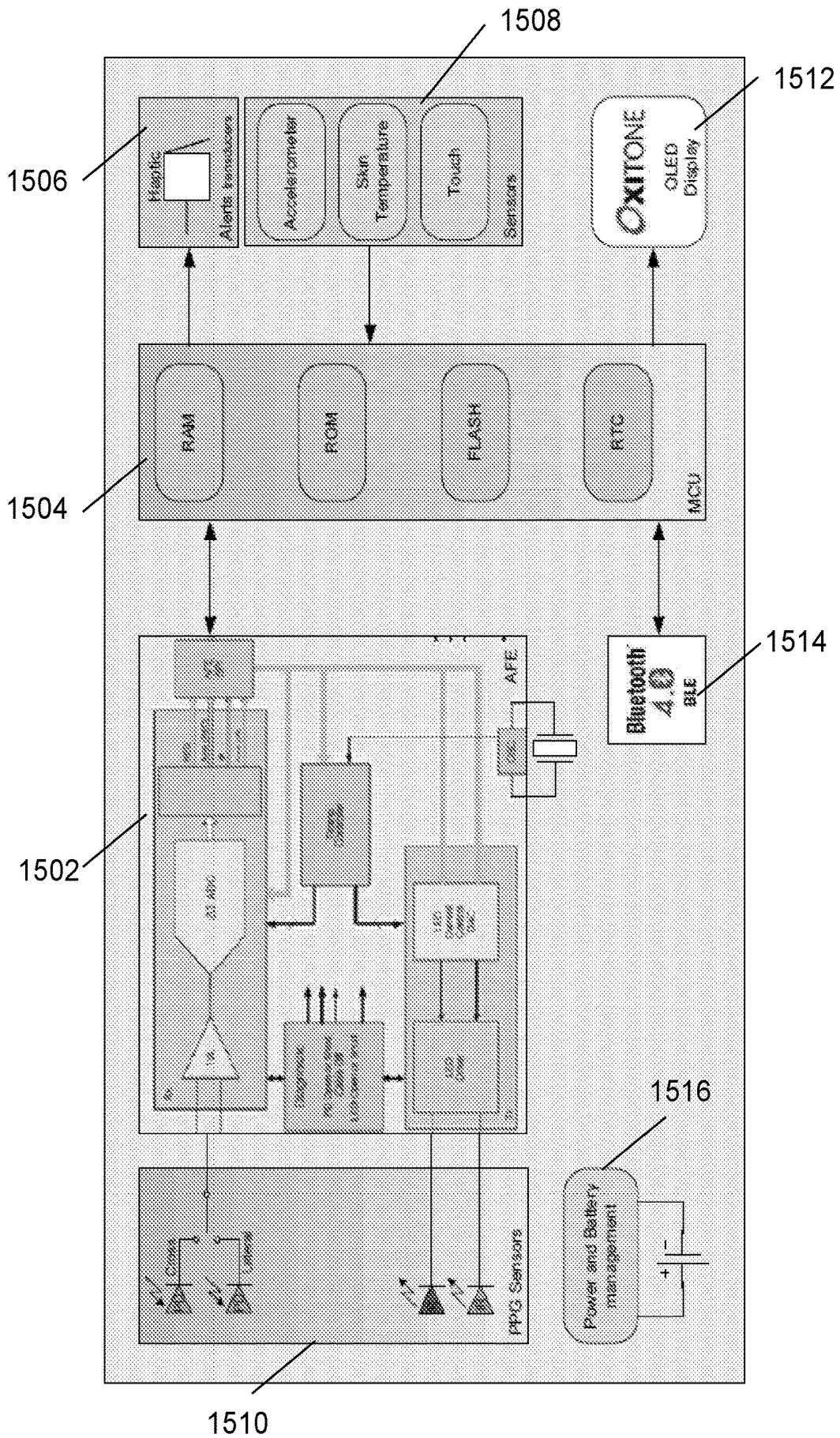

FIG. 15

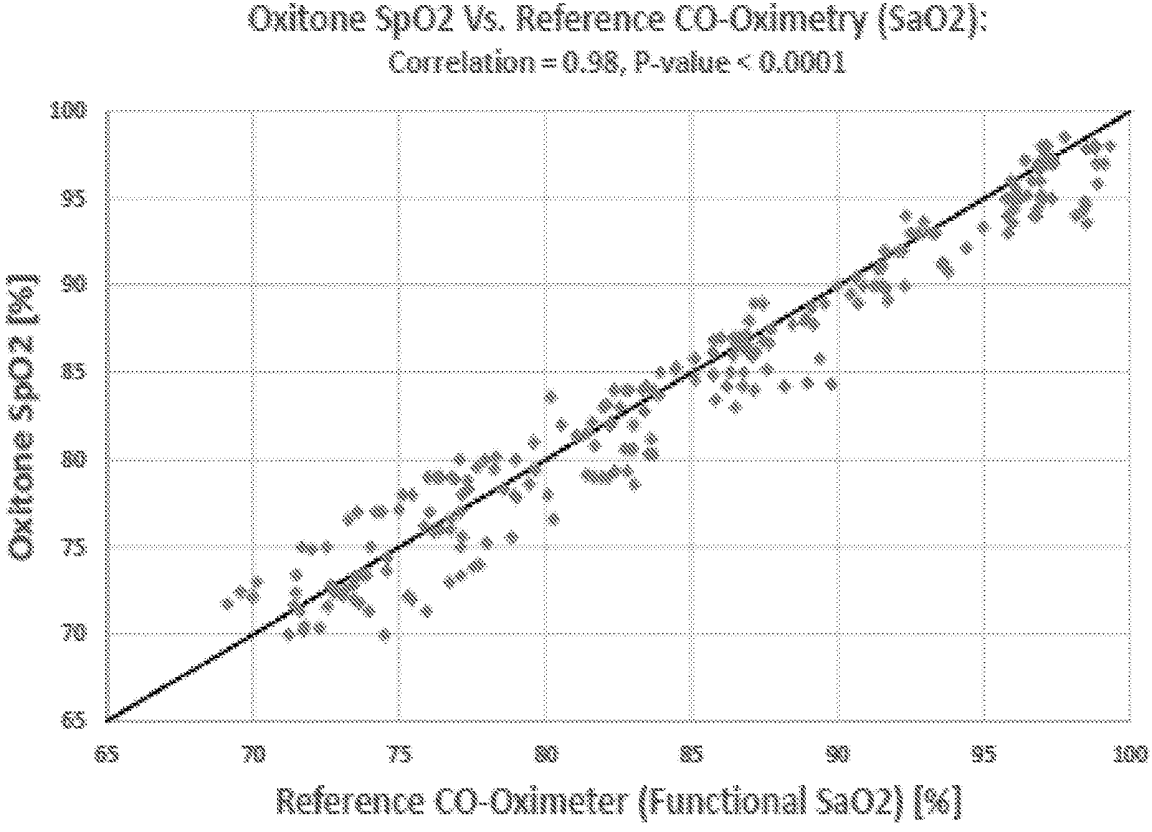

FIG. 16

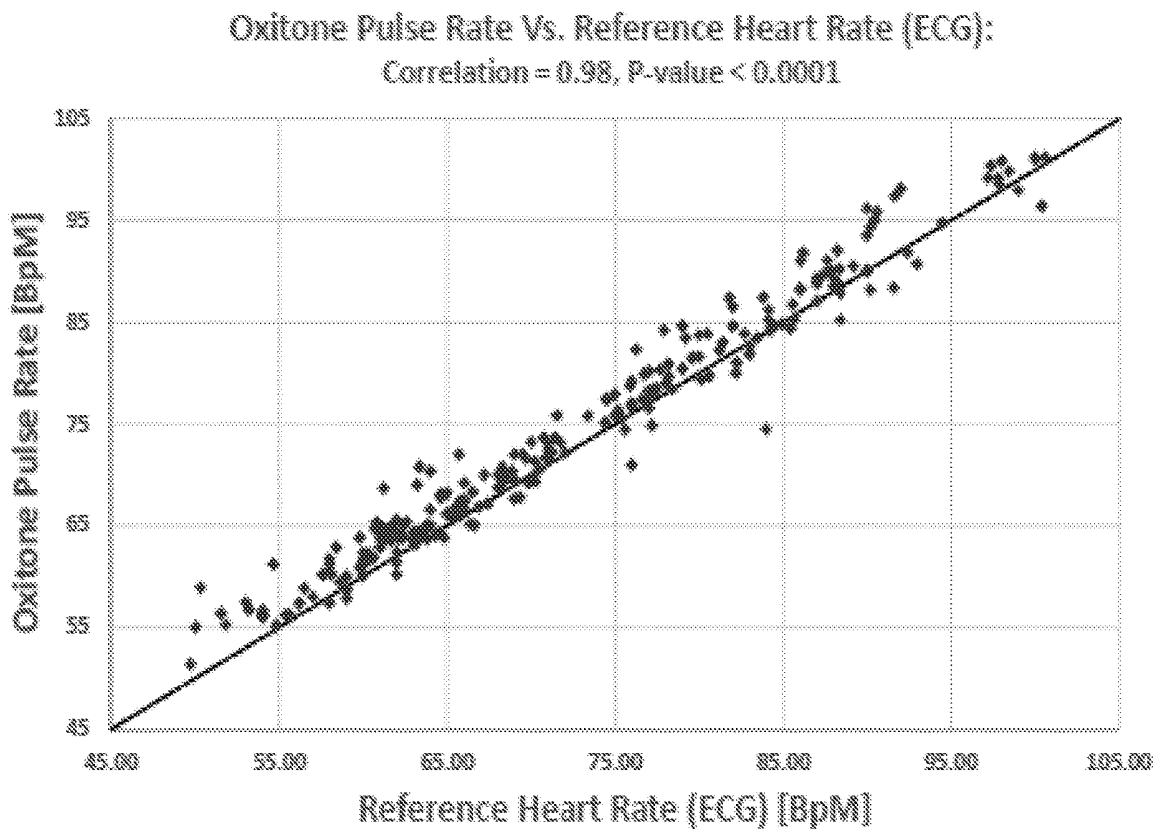

FIG. 17

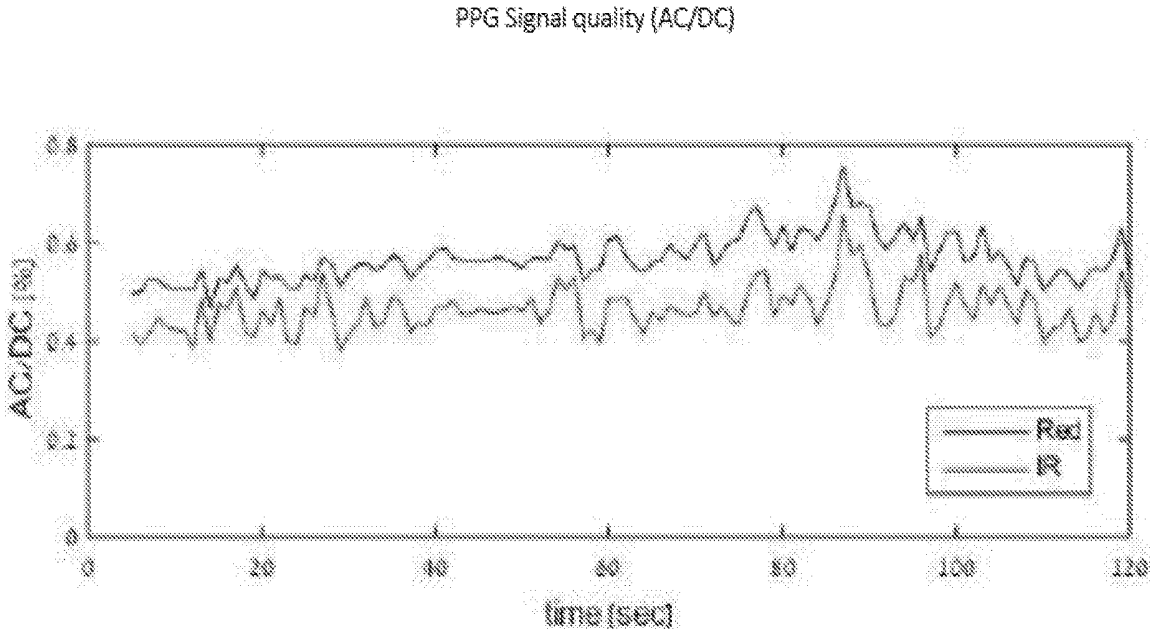
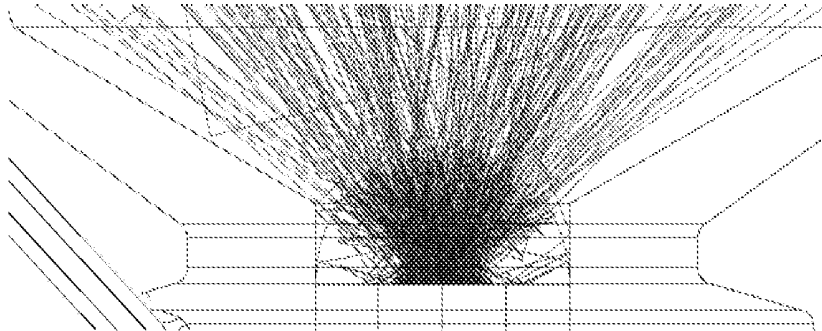
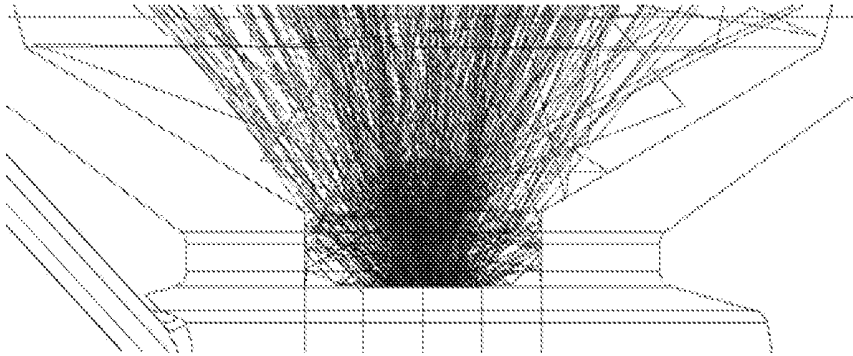

FIG. 18



Dome attached to LED w/o space

FIG. 19A



10um space between dome and LED

FIG. 19B

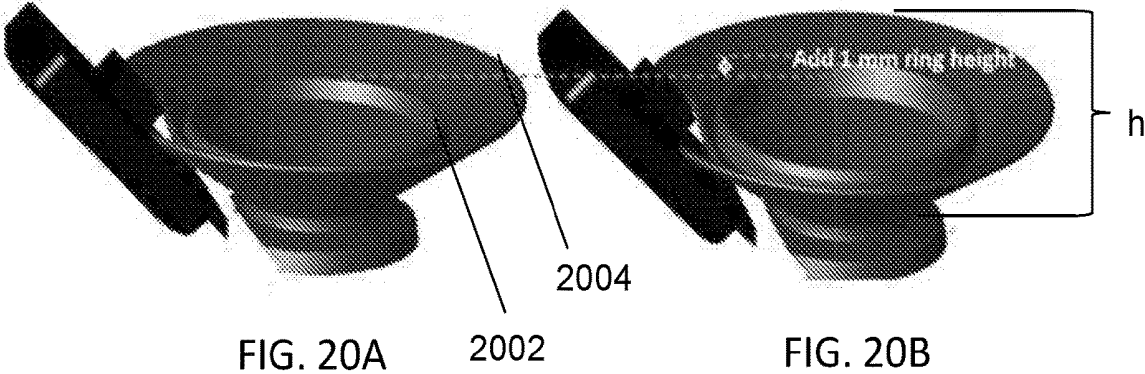

Stray light is reduced by 80% when cap angle is increased by 2.5° (from original 56.5° to 59°)

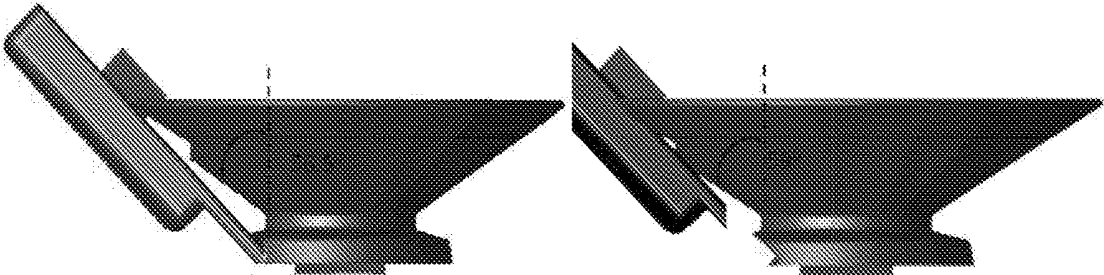

FIG. 21A

FIG. 21B

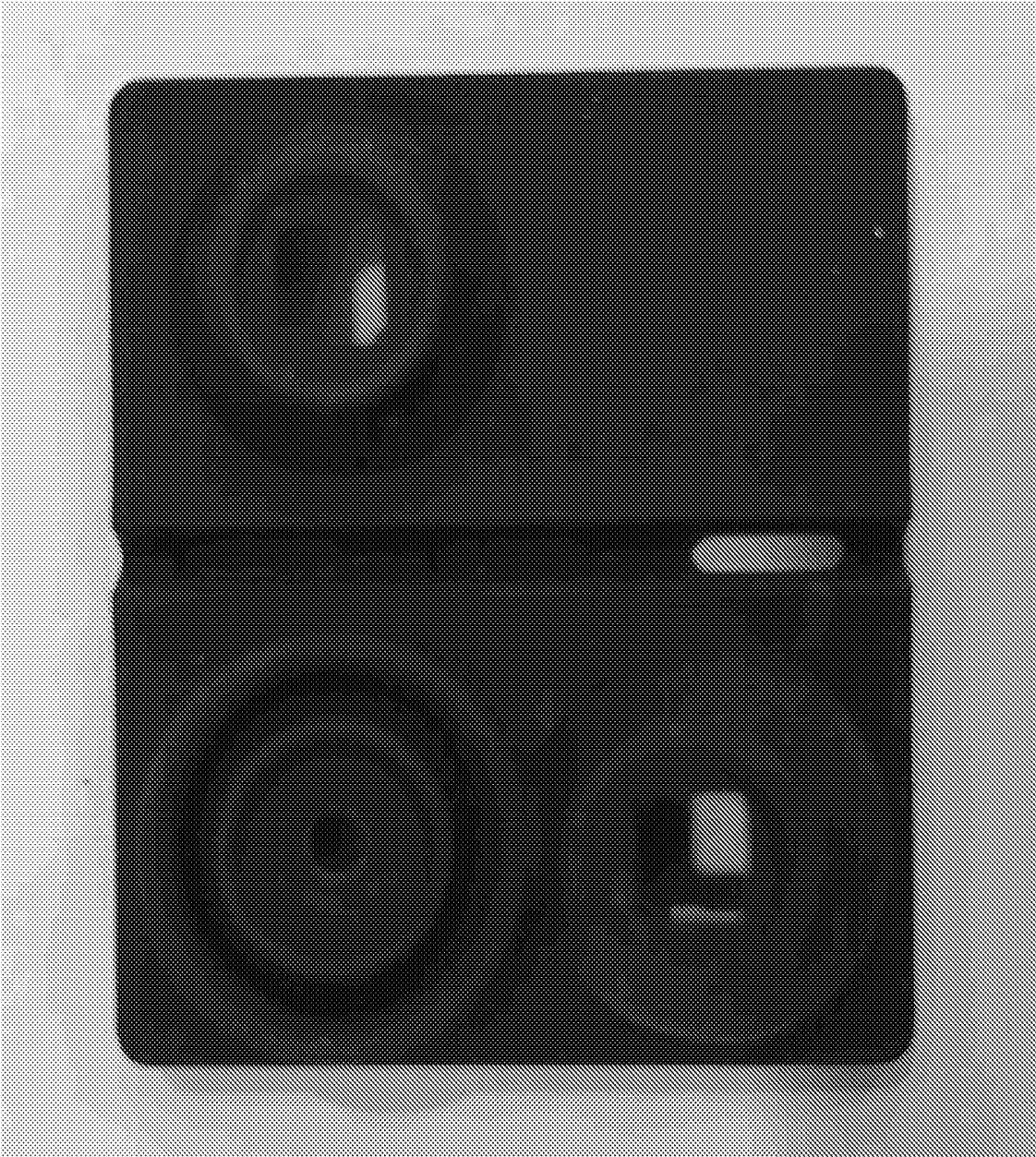

FIG. 22

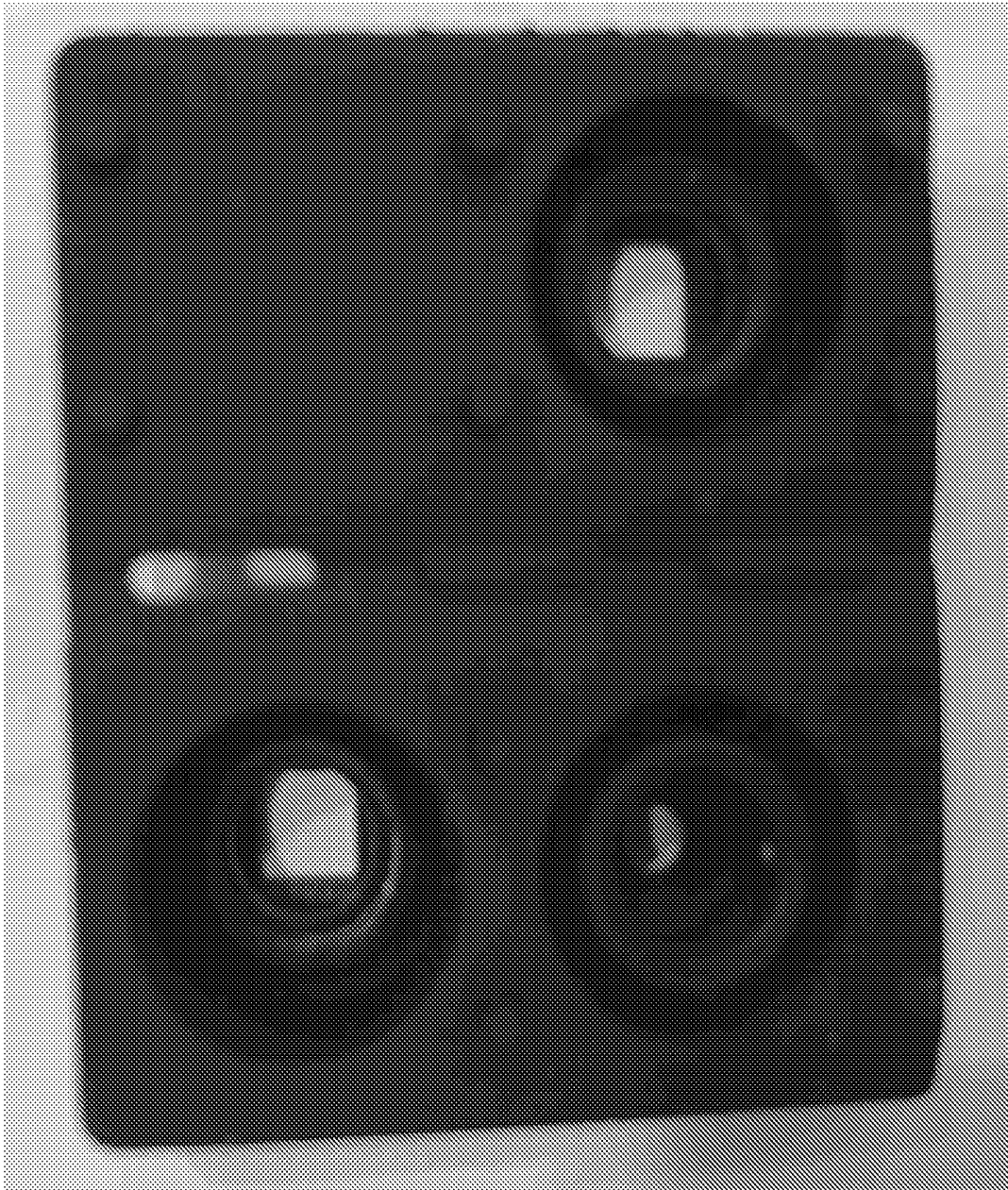

FIG. 23



FIG. 24



FIG. 25



FIG. 26



FIG. 27



FIG. 28



FIG. 29

WRIST-SENSOR PULSE OXIMETRY DEVICE AND METHOD

CROSS-REFERENCE TO RELATED APPLICATION

[0001] This claims priority to U.S. Provisional Patent Application No. 62/438,501, filed Dec. 23, 2016, which is hereby incorporated by reference herein in its entirety.

TECHNICAL FIELD

[0002] Embodiments of the present invention relate to a device (e.g., pulse oximetry device) that can be worn on a wrist and associated methods.

BACKGROUND OF THE RELATED ART

[0003] This section is intended to introduce various aspects that may be related to embodiments of the present invention, which are described and/or claimed below. This discussion is believed to be helpful in providing background information to facilitate a better understanding of the various aspects of embodiments of the present invention. Accordingly, it should be understood that these statements are to be read in this light, and not as admissions of prior art.

[0004] In the field of medicine, doctors often desire to monitor certain physiological characteristics of their patients. Accordingly, a wide variety of devices have been developed for monitoring physiological characteristics of a patient. Such devices provide patients, doctors, and other healthcare personnel with the information they need to secure the best possible healthcare for their patients. As a result, such monitoring devices have become an indispensable part of modern medicine.

[0005] One technique for monitoring certain physiological characteristics of a patient is commonly referred to as pulse oximetry, and the devices built based upon pulse oximetry techniques are commonly referred to as pulse oximeters. Pulse oximetry may be used to measure various blood characteristics, such as the arterial blood oxygen saturation of hemoglobin (SPO₂), and the rate of blood pulsations corresponding to each heartbeat of a patient. In fact, the “pulse” in pulse oximetry refers to the time varying amount of arterial blood at the measurement site during each cardiac cycle. Those skilled in the art will appreciate the pulse oximetry techniques used for obtaining the above physiological parameters which may also be termed photoplethysmography or, in short, PPG.

[0006] Pulse oximeters typically utilize a non-invasive optical sensor that detects the light response from within a patient's tissue indicative of the amount of light absorbed within the tissue at the illuminated site. One or more of the above physiological characteristics may then be calculated based upon the amount of the absorbed light. More specifically, the light passed through the tissue is typically selected to be of one or more light wavelengths that may be absorbed by the blood in an amount correlative to the amount of the hemoglobin constituent present in the blood. The amount of light absorbed at different light wavelengths may then be used to estimate the arterial blood hemoglobin related parameters using various algorithms. Pulsatile changes in the volume of the arterial blood at the illuminated site during blood pressure wave propagation alter the intensity of the light response detected by the sensor's photodetector.

[0007] The quality of the pulse oximetry measurement depends in part on the blood perfusion characteristics of the tissue illuminated by the light and in part on the magnitude of the pulsatile changes in the blood volume within the illuminated tissue. Pulse oximetry techniques typically utilize a tissue site that is well perfused with blood, such as a patient's finger, toe, or earlobe, on which to place the sensor.

[0008] For example, FIG. 1 illustrates a sensor 10 adapted to be placed on a finger 12 of a user, such as a patient, according to the prior art. The sensor 10 includes a clip formed of two portions 14 and 16 adapted to clip and constrain the sensor 10 to finger 12 while pulse oximetry measurements are taken. Sensors of a type similar to the sensor 10 are typically coupled to cables 18 that couple the sensor 10 to monitoring systems adapted to receive and process the signals from the sensor 10. Accordingly, such sensor using in continuous monitoring mode typically requires the patient (or user) to be confined to a certain area, in close vicinity of the monitoring system, thereby limiting patient mobility. In addition, pinch pressure applied by clip portions 14 and 16 on the finger 12 of the patient may overtime feel uncomfortable or become overbearing to the patient to the extent the patient may want to remove the sensor 10 and cease otherwise required monitoring. As a result, such sensors are not suitable for prolonged and continuous pulse oximetry measurements.

[0009] Further, as may occur with any physiological signals measuring device, the appearance of artifacts and other anomalies in the measured data can alter and/or degrade the quality of collected data to the extent that data may not be useful for providing reliable indication of occurring physiological processes. In that regard, pulse oximetry devices are no exception, as such devices may generally be prone to artifacts arising, for example, from patient motion, which may be random, voluntary or involuntary. Consequently, artifacts arising out of such circumstances can distort and skew obtained data, ultimately adversely affecting the quality of the pulse oximetry measurements. Although the accuracy and reliability of the physiological signals measurements is in large affected by the amount of blood perfusion, as well as by the distribution of the nonpulsatile blood within a tissue site, an increased or excessive amount of motion artifact can become a significant contributing factor to the overall pulse oximetry measurement. Due to the aforementioned facts, reflection geometry of the pulse oximetry measurements may not be applicable to various portions of user's body, such as those characterized as having weak blood perfusion, as well being prone to strong motion artifacts. In addition, such body portions may not be suitable for accommodating pulse oximetry devices employing forward transmission geometry in which light emitters and detector are disposed at opposite sides. In such a configuration, portions of the body from pulse oximetry measurements are desired may have tissue layers that are too thick for the light penetrate, thereby impeding the pulse oximetry measurements.

[0010] The following patent disclosures by the applicant are hereby incorporated by reference herein in their entireties: U.S. Pat. No. 9,314,197, titled “Wearable pulse oximetry device,” and U.S. Pat. Nos. 8,868,149 and 9,149,216, each titled “Photoplethysmography device and method.”

BRIEF SUMMARY OF EMBODIMENTS OF
THE PRESENT INVENTION

[0011] In some embodiments of the present invention, a device (e.g., pulse oximetry device) and corresponding methods of use are provided.

[0012] For example, in some embodiments, a pulse oximetry device is provided that includes at least two light sources having different wavelengths, at least one detector responsive to said different wavelengths, a wrist strap, and a casing coupled to the wrist strap for housing the at least two light sources and the at least one detector. The wrist strap may include a projection (e.g., generally concave projection) adapted to fit snugly against a wearer's wrist and remain in place even when the wearer is moving. In some embodiments, the generally concave projection further comprises one or more ridges. In some embodiments, the generally concave projection includes an elastomer material (e.g., silicon) having a softness (durometer) of between 30 to 75 Shore A (e.g., approximately 50 Shore A). In some embodiments, the generally concave projection may include a hollow interior portion for receipt of medication.

[0013] In some embodiments, the wrist strap of a pulse oximetry device may include a first portion and a second portion adapted for attachment to the first portion (e.g., via a clasp) to fixate the wrist strap around a user's wrist. The first portion of the wrist strap may include the generally concave projection. The second portion of the wrist strap may include a second projection that assists to fixate the device at a fixated area corresponding to a distal end of the wearer's ulna bone. In some embodiments, the second projection is a curved projection that generally follows a contour of the wearer's ulna bone. In some embodiments, the second projection is formed generally in the shape of part of a dome or sphere.

[0014] In some embodiments, each of the at least two light sources and the at least one detector is positioned within the casing such that when the wrist strap is affixed around the wearer's wrist the least two light sources and the at least one detector are positioned adjacent to the distal end of the ulna and closer to the ulna than the radius, and the at least one detector is positioned to detect light emitted from the at least two light sources.

[0015] In some embodiments of the present invention, a pulse oximetry device is provided that includes at least two light sources having different wavelengths, at least one detector responsive to said different wavelengths, a wrist strap, and a casing coupled to the wrist strap for housing the at least two light sources and the at least one detector, wherein each of the at least two light sources and the at least one detector is angled generally toward a virtual center point of the distal end of a wearer's ulna bone and each of the at least two light sources and the at least one detector has a different axis.

[0016] In some embodiments, each of the at least two light sources and the at least one detector is positioned within the casing such that when the wrist strap is affixed around the wearer's wrist the least two light sources and the at least one detector are positioned adjacent to the distal end of the ulna and closer to the ulna than the radius, and the at least one detector is positioned to detect light emitted from the at least two light sources.

[0017] In some embodiments, at least one of the at least two light sources and the at least one detector of a pulse oximetry device includes a generally dome-shaped or conical-shaped structure that assists to fixate the pulse oximetry device, and its corresponding at least two light source(s) and at least one detector, at a fixated area at, adjacent to, or at a periphery of, a distal end of a wearer's ulna bone.

[0018] In some embodiments of the present invention, a pulse oximetry device is provided that includes at least two light sources having different wavelengths, at least one detector responsive to said different wavelengths, a wrist strap, and a casing coupled to the wrist strap for housing the at least two light sources and the at least one detector, wherein the casing comprises a first portion and a second portion that extend at an angle relative to each other. In some embodiments, a display may be fixed to the first portion of the casing, and the at least two light sources and the at least one detector may be fixed to the second portion of the casing. In some embodiments, the first portion of the casing and the second portion of the casing together generally resemble the shape of the letter "L." In some embodiments, the casing is strong enough to maintain the positioning of the at least two light sources and the at least one detector when the device is worn by a wearer, while simultaneously having slight pliability or elasticity to act as a movement dampening cushion that reduces measurement artifacts of the pulse oximetry device resulting from movement of the wearer.

[0019] In some embodiments, the casing includes a third portion that joins the first portion and the second portion of the casing, where the third portion allows for slight angular movement between the first portion and the second portion of the casing in response to normal forces while the pulse oximetry device is being worn by a user.

[0020] In some embodiments, the casing of the pulse oximetry device includes aluminum or thermoplastic urethane (TPU). In some embodiments, the casing has a durometer of between 25 Shore A and 35 Shore A.

[0021] In some embodiments, each of the at least two light sources and the at least one detector is positioned within the casing such that when the wrist strap is affixed around the wearer's wrist the least two light sources and the at least one detector are positioned adjacent to the distal end of the ulna and closer to the ulna than the radius, and the at least one detector is positioned to detect light emitted from the at least two light sources.

[0022] In some embodiments of the present invention, the pulse oximetry device may include a pad that is mounted or otherwise fixed generally to an inner side of the casing, wherein the pad includes one or more barriers that function to fit snugly against a wearer's wrist and prevent stray light from entering a measuring area of the at least two light sources and the at least one detector when the pulse oximetry device is worn by a wearer.

[0023] In various embodiments of the present invention, the at least two light sources and said at least one light detector of a pulse oximetry device may be disposed relative to one another such that emitted light is adapted to transilluminate via a wearer's ulna before reaching the at least one light detector. In other embodiments according to the present invention, the at least two light sources and the at least one light detector may be disposed relative to one another such that the emitted light is adapted to reach the at least one light detector in a reflective mode.

[0024] In various embodiments of the present invention, the at least two light sources of a pulse oximetry device may be selected from the group consisting of: LEDs having different wavelength ranges, laser diodes having different

wavelengths, and a combination of LEDs and laser diodes having wavelengths outside the range of said LEDs.

[0025] In various embodiments of the present invention, the device may include a processor configured to calculate oximetry data and/or other data based at least in part on light detected by at least one detector.

[0026] Additional embodiments of the present invention are described below in connection with the Figures.

BRIEF DESCRIPTION OF THE DRAWINGS

[0027] For a better understanding of some embodiments of the present invention and to show how the same may be carried into effect, reference will now be made, by way of example, to the accompanying drawings in which like numerals designate corresponding elements or sections throughout. In the accompanying drawings:

[0028] FIG. 1 is an illustration of a prior art pulse oximeter;

[0029] FIG. 2 is a perspective view of a device (e.g., wrist-type pulse oximeter) in accordance with an embodiment of the present invention;

[0030] FIG. 3 is perspective view of the wrist-type pulse oximeter of FIG. 2, illustrating, for example, mechanical features for dampening the effects of a user's movement on sensor measurements and for fixating the device to a user's wrist, and showing a configuration of light source(s) and detector(s) according to some embodiments of the present invention;

[0031] FIGS. 4A and 4B are side and perspective views, respectively, of the pulse oximeter of FIG. 2 in accordance with some embodiments of the present invention;

[0032] FIG. 5 is another side view of the pulse oximeter of FIG. 2 in accordance with some embodiments of the present invention;

[0033] FIGS. 6A, 6B, and 6C are a side view, and two perspective views, respectively, of the pulse oximeter of FIG. 2 in accordance with some embodiments of the present invention;

[0034] FIGS. 7 and 8 are additional perspective views of the pulse oximeter of FIG. 2 in accordance with some embodiments of the present invention;

[0035] FIG. 9 is a bottom view of the pulse oximeter of FIG. 2 in accordance with some embodiments of the present invention;

[0036] FIG. 10 is a top view of the pulse oximeter of FIG. 2 in accordance with some embodiments of the present invention;

[0037] FIG. 11 is another side view of the pulse oximeter of FIG. 2 in accordance with some embodiments of the present invention;

[0038] FIGS. 12 and 13 are additional perspective views of the pulse oximeter of FIG. 2 in accordance with some embodiments of the present invention;

[0039] FIG. 14 is an exploded view showing various components of the pulse oximeter of FIG. 2 in accordance with some embodiments of the present invention;

[0040] FIG. 15 is a block circuit diagram illustrating hardware functionality of the pulse oximeter of FIG. 2 in accordance with some embodiments of the present invention;

[0041] FIG. 16 is a graph demonstrating the accuracy of pulse oximetry data produced by a pulse oximeter in accordance with FIG. 2 according to some embodiments of the present invention;

[0042] FIG. 17 is a graph demonstrating the accuracy of pulse rate data produced by a pulse oximeter in accordance with FIG. 2 according to some embodiments of the present invention;

[0043] FIG. 18 is a graph of PPG signal quality by a pulse oximeter in accordance with FIG. 2 according to some embodiments of the present invention;

[0044] FIGS. 19A, 19B, 20A, 20B, 21A, and 21B illustrate embodiments of light source configurations for a wrist-worn pulse oximeter according to some embodiments of the present invention;

[0045] FIGS. 22 and 23 illustrate housings for light source(s) and detector(s) according to some embodiments of the present invention; and

[0046] FIGS. 24 through 29 illustrate multiple views of a device (e.g., wrist-type pulse oximeter) in accordance with another embodiment of the present invention.

DETAILED DESCRIPTION OF ILLUSTRATIVE EMBODIMENTS

[0047] With specific reference now to the drawings in detail, it is to be understood that the particulars shown are by way of example and for purposes of illustrative discussion of preferred embodiments of the present invention only. The description taken in conjunction with the drawings will make apparent to those of ordinary skill in the art how the several forms and embodiments of the invention may be embodied in practice.

[0048] It is also to be understood that embodiments of the invention are not limited in their application to the details of construction and the arrangement of the components set forth in the following description or illustrated in the drawings. Embodiments of the invention may be practiced or carried out in various other ways. In addition, it is to be understood that the phraseology and terminology employed herein is for the purpose of description and should not be regarded as limiting.

[0049] Turning now to the figures, FIG. 2 is a perspective view of a device 200 in accordance with an exemplary embodiment of the present invention. Device 200 may be a wrist-type oximeter device adapted to be worn on a wrist of a user, as further shown in FIG. 2. In some embodiments, device 200 is adapted to obtain data including, for example, pulse data, oxygen saturation (SPO2) data, and/or other data from a user while the user wears device 200 on the wrist. Hence, a user can wear the device 200 in manner similar to that of wearing a watch, a wrist band or any article of clothing, ornament, or garment adapted to be worn on the wrist of the user. In this manner, a user can wear device 200 while performing any routine and ordinary operation the user would otherwise perform in everyday life, such as walking, running, cycling and so forth. In accordance with embodiments of the present technique, device 200 can be conveniently worn at any time or place by those users required to or wishing to obtain, for example, pulse oximetry and pulse rate data without being attached to elaborate monitoring device or being confined to certain monitoring areas. Thus, the device 200 is a self-contained, self-powered device adapted to obtain, analyze and process, for example, various light electromagnetic signals from which pulse oximetry data is ultimately obtained. Device 200 may further include wired or wireless interfaces whereby the device 200 can communicate and/or relay data signals to external and/or remote devices. Hence, in some embodiments, device

200 can collect and provide the oximetry data to any remote users, institutions such as hospitals or clinics, or anyone who requires or has interest in such pulse oximetry data of the user.

[0050] As illustrated in FIG. 2, device **200** may include a display **202** that displays, for example, data measured by device **200**. Such data may include pulse rate data (e.g., “PULSE 76”), and data regarding the wearer’s blood oxygen saturation of hemoglobin (e.g., “SPO² 97%”). In some embodiments, display **202** may be an LED display, such as, for example, an organic light-emitting diode (“OLED”) display, liquid crystal display (“LCD”), or any other suitable display. In some embodiments, device **200** may include one or more physical buttons or user input interfaces (e.g., alphanumeric buttons or user interface where by the user can enter any combination of numbers and/or letters as desired or needed while the device is in use). Alternatively or additionally, in some embodiments, one or more buttons or user interface inputs may be placed at any side, or sides, of device **200** or any other area of device **200** that is accessible to the user. In some embodiments, device **200** may alternatively or additionally measure and/or display other data, including, for example, data regarding one or more vital signs, data regarding one or more blood analytes, blood pressure data (e.g., “BP 117/76”), and/or data regarding stroke volume (e.g., “SV 73”).

[0051] As further illustrated by FIGS. 2 and 3, device **200** includes a wrist strap or band (**204a**, **204b**) that is adapted to extend around a wearer’s wrist. In some embodiments, the wrist band may be made up of any flexible and/or stretchable material, such as rubber, silicon, soft plastic, or cloth or any combination thereof for providing the user a comfortable fit and feeling while wearing the device **200**. The wrist band may include first side **204a** adapted to join with a second side **204b** via a clasp **206**, which may include, for example, a male attachment member for pairing with one or more suitable adjustment holes formed in wrist band **204a** (as shown) based on the wearer’s wrist size, a friction-fit clasp, or any other suitable attachment mechanism (e.g., hook and loop or velcro).

[0052] In some embodiments, wrist band **204a** may include projection **208**. Projection **208** may be adapted to dampen the effects of a wearer’s movement on sensor measurements of device **200** and to fixate the device to a wearer’s wrist when the two sides **204a** and **204b** of the wrist band are joined. In some embodiments, projection **208** may have an outer surface that is generally concave (see also e.g., FIGS. 4A, 12, and 14). Such a contour may enable projection **208**, and thus device **200**, to fit snugly against the wearer’s wrist and remain in place even when the wearer is moving. In some embodiments, projection **208** may include, for example, one or more ridges **224** to further enable device **200** to fit snugly against the wearer’s wrist and remain in place irrespective of whether the wearer is moving (see also e.g., FIGS. 4A, 12 and 14). Projection **208** may be made up of any flexible and/or stretchable material, such as rubber, silicon, soft plastic, or cloth or any combination thereof for providing the user a comfortable fit and feeling while wearing the device **200**. For example, in some embodiments, projection **208** may be formed entirely from or otherwise include, at least in part (e.g., a coating), an elastomer material (e.g., silicon) having a softness (durometer) of between 30 to 75 Shore A (e.g., approximately 50 Shore A). In some embodiments, projection **208** may be at least

partially hollow and may contain a space, for example, for storage of emergency medicine such as one or more pills for emergency intervention. In some embodiments, projection **208** may be integrally formed with or otherwise attached to wrist strap **204a**. In some embodiments, wrist strap **204a** may contain an opening or seal **226** through which the emergency medicine may be inserted and accessed (see also e.g., FIG. 5). The opening or seal **226** may open and close via any suitable mechanism, including, for example, a friction fit, a snap fit, a resealable membrane, or velcro.

[0053] In some embodiments, wrist straps **204a** and **204b** may couple to a casing (**210a**, **210b**), which may house components including, for example, various electrical, mechanical, optical and other devices, such as batteries, processors, integrated circuit boards, one or more sensors, one or more light sources such as light emitting diodes, shunts, and/or other devices contributing to the functionality and integrity of the device **200**. In some embodiments, display **202** (FIG. 2) may be mounted or otherwise fixed to a first, top portion **210a** of the casing. In some embodiments, top portion **210a** of the casing may house or otherwise include one or more (e.g., all) of the components in the block circuit diagram of FIG. 15, described below. In some embodiments, one or more light sources (e.g., **212**), such as light emitting diodes (LEDs), and/or one or more sensors (e.g., **214** and/or **216**), such as photo diodes, may be mounted to, fixed to, or otherwise housed by a second portion **210b** of the casing. In some embodiments, the casing (e.g., rigid casing) when viewed from the side may be generally L-shaped in that second portion **210b** may extend at an angle relative to first portion **210a** of the casing generally around or at the side of a wearer’s wrist (see also e.g., FIGS. 4a and 14). In some embodiments, the casing (**210a**, **210b**) may be made up of any suitably strong and durable material, for example, metal or hard plastic, that is adapted for housing and protecting components of device **200** from external elements and forces. Casing (**210a**, **210b**) may be suitably strong to maintain the positioning of light source(s) **212** and/or sensor(s) **214** and **216** of device **200**. In some embodiments, the casing (**210a**, **210b**) simultaneously may have slight pliability or elasticity to act as a movement dampening cushion that reduces measurement artifacts of device **200** resulting from movement of the wearer. For example, a joining interface (e.g., elbow) **210c** between first portion **210a** and second portion **210b** of the casing may allow for slight angular movement between first portion **210a** and second portion **210b** in response to normal forces while device **200** is being worn by a user. For example, in some embodiments, casing (**210a**, **210b**, **210c**) may be formed entirely from or otherwise include aluminum and/or thermoplastic urethane (TPU) having a durometer of, for example, between 25 Shore A and 35 Shore A (e.g., approximately 30 Shore A). In some embodiments, all of portions **210a**, **210b**, and **210c** may be integrally formed together, for example, as shown and described further below in connection with FIG. 14.

[0054] In some embodiments, device **200** may include structure **218** that assists to fixate device **200** at a fixated area corresponding to a distal end of the wearer’s ulna bone, where the fixated area is used as a measuring area. Structure **218** may be a curved projection that is formed generally in the shape of part of a dome or sphere. In some embodiments, the measurement is carried out by a one or more sensors or detectors **214** and/or **216** positioned above or adjacent to the

fixated area to detect light emitted by one or more light sources **212**. For example, the light sources **212** may be two light sources having different wave lengths that are located at, above or adjacent to (e.g., at a periphery of) the fixated area. For example, light sources **212** may include a red light emitting diode (LED) for emitting light of wavelength 660 nm and an infrared LED for emitting light of wavelength 940 nm. In some embodiments, one or more of light source(s) **212**, detector **214**, and detector **216** may include a generally dome-shaped or conical-shaped structure that assists to fixate device **200**, and its corresponding light source(s) and sensors, at a fixated area corresponding to a distal end of the wearer's ulna bone (see also e.g., FIGS. **4B** and **20A**, **20B**, **21A**, and **21B**). In some embodiments, device **200** may include only one sensor (e.g., **214** or **216**).

[0055] In some embodiments, structure **218** may be part of or integral to a pad that is mounted or otherwise fixed generally to an inner side of casing portion **210b**. In some embodiments, some or all of the pad (e.g., including structure **218**) may be formed entirely from or otherwise include a flexible and/or stretchable material, such as rubber, silicon, soft plastic, or cloth or any combination thereof for providing the user a comfortable fit and feeling while wearing the device **200**. For example, in some embodiments, the pad (e.g., including structure **218**) may be formed entirely from or otherwise include an elastomer material (e.g., silicon) having a softness (durometer) of between 30 to 75 Shore A (e.g., approximately 50 Shore A), which may be the same material that is used for projection **208**. In some embodiments, the pad may include one or more barriers (e.g., fins) **220** that function to, for example, fit snugly against a wearer's wrist and/or to prevent ambient or stray light from entering the measuring area when device **200** is worn by a user. The pad may include, for example, a first barrier **220** on one side of the pad and a second barrier on a second, generally opposite side of the pad. For example, in some embodiments, each barrier **220** may be approximately 1 to 5 millimeters wide and extend approximately 1 to 5 millimeters mm outward from the user-facing surface of the pad. In some embodiments, the barriers **220** may extend along the entire, or any part(s) of, the sides of the pad.

[0056] In some embodiments, each of light source(s) **212** and sensor(s) **214** and/or **216** may generally face generally towards the distal end of the wearer's ulna bone when the device is worn by a user. In some embodiments, notwithstanding this general positioning, each of light source(s) **212** and sensor(s) **214** and/or **216** may have its own different and independent axis, for example, as reflected by unique x, unique y, and unique z coordinates and angular orientation relative to a virtual center point **222** of the distal end of a wearer's ulna bone (see also e.g., FIGS. **4A** and **4B**). In other words, in some embodiments, the line of sight or axis relative to the virtual center point **222** of the distal end of a wearer's ulna bone is asymmetrical for each of light source(s) **212** and sensor(s) **214** and/or **216**. For example, in such embodiments, even though light source(s) **212** and sensor **214** are generally adjacent to one another, each has a different axis resulting from the manner in which each of **212** and **214** is angled generally toward the virtual center point **222** of the distal end of a wearer's ulna bone. As another example, even though light source(s) **212** and sensor **216** are generally adjacent to one another, each has a different axis resulting from the manner in which each of

212 and **214** is angled generally toward the virtual center point **222** of the distal end of a wearer's ulna bone.

[0057] In some embodiments, reflections of light from light source(s) **212** are measured by sensor(s) **214** and/or **216** at neither a reflection mode nor a transmission mode, but rather at an angle between, for example, 20° and 160° from the emitted light. This mode, termed trans-illumination, allows achieving an excellent signal to noise ratio that for the first time enables continuous and reliable measurement of oximetry data on the wrist. The term "trans-illumination" as used herein, is a mode of optical measurement, in which the measured light is reflected off a surface at an angle larger than 0° (which correspond to simple reflection) and smaller than 180° (which correspond to simple transmission). Commonly, but not exclusively, the reflection angles in trans-illumination mode are between approximately 20° and approximately 160° . In trans-illumination mode, the measured light is emitted from the light source, hits the reflective surface, which may be curved, at an angle, and is reflected at an angle to the detector. In practice, trans-illumination includes light going over various light paths, having in common an origin in the light source and a measurement in the detector. In other embodiments, reflections of light from light source(s) **212** are measured by sensor(s) **214** and/or **216** in a reflection mode. In some embodiments, reflections of light from light source(s) **212** are measured by one of sensor(s) **214** and/or **216** in a transillumination mode, and by the other of sensor(s) **214** and/or **216** in a reflection mode.

[0058] FIGS. **4A** and **4B** are side and perspective views, respectively, of the device of FIG. **2** in accordance with some embodiments of the present invention. In FIG. **4A**, the portions **210a**, **210b**, and **210c** of the casing of device **200** are illustrated from the side. In addition, the virtual center point of the distal end of a wearer's ulna bone is illustrated schematically as point **222**. Viewing device **200** in the direction indicated by section A-A in FIG. **4A** produces the view illustrated in FIG. **4B**. In FIG. **4B**, the light source(s) **212** and sensor(s) **214** and/or **216** are shown generally from the point of view of a wearer's wrist. As can be seen, each of **212**, **214**, and **216** has a different axis resulting from the manner in which each of them is angled generally toward the virtual center point **222** of the distal end of a wearer's ulna bone.

[0059] FIG. **5** is another side view of the device of FIG. **2** in accordance with some embodiments of the present invention. FIG. **5** shows, for example, wrist strap **204a** of device **200** and opening **226** through which emergency medicine (e.g., one or more pills) may be inserted to and accessed from an at least partially hollow portion of projection **208**. Viewing device **200** in the direction indicated by section B-B in FIG. **5** produces the view illustrated in FIG. **4A**.

[0060] FIGS. **6A**, **6B**, and **6C** are an additional side view, and two perspective views, respectively, of the device of FIG. **2** in accordance with some embodiments of the present invention. Viewing device **200** in the direction indicated by section C-C in FIG. **6A** produces the view illustrated in FIG. **6B**. In some embodiments, device **200** may include one or more projections **602** (e.g., rounded projections) that function, for example, to increase the wearer's comfort and fit of the device to the wearer's wrist. Projections **602** may be formed entirely from or otherwise include a flexible and/or stretchable material, such as rubber, silicon, soft plastic, or cloth or any combination thereof for providing the user a

comfortable fit and feeling while wearing the device **200**. For example, in some embodiments, projections **602** may be formed entirely from or otherwise include an elastomer material (e.g., silicon) having a softness (durometer) of between 30 to 75 Shore A (e.g., approximately 50 Shore A), which may be the same material that is used for projection **208** and/or pad **220**. In other embodiments, projections **602** may be formed entirely from or otherwise include aluminum and/or thermoplastic urethane (TPU) having a durometer of, for example, between 25 Shore A and 35 Shore A (e.g., approximately 30 Shore A), which may be the same material as the casing (**210a**, **210b**, **210c**). In some embodiments, projections **602** may be formed integrally with the casing (**210a**, **210b**, **210c**).

[0061] FIG. 6C illustrates additional details regarding light source(s) **212** and sensor(s) **214** and/or **216** according to some embodiments of the present invention. Viewing device **200** in the direction indicated by section D-D in FIG. 6A produces the view illustrated in FIG. 6C. In some embodiments, the center points between light source(s) **212** and detector **216** may be approximately 11.3 millimeters (mm) apart. In other embodiments, they may be between about 7 to 15 mm apart, or about 8 to 13 mm apart. A distance between a center point of light source(s) **212** and an outer ring of light source(s) **212** may be between 1 and 8 mm, or between 1 and 4 mm (e.g., approximately 3.1 mm apart). In some embodiments, the center points between light source(s) **212** and detector **214** may be approximately 13.6 millimeters (mm) apart. In other embodiments, they may be between about 9 to 17 mm apart, or about 10 to 14 mm apart. In some embodiments, projection **218** may have a virtual circumference equal to about 19 mm, which may be generally sufficient to encompass at least parts of light source(s) **212** and/or detector **214**. In other embodiments, a virtual circumference of projection **218** may be about 15 to 24 mm and may depend (e.g., be selected based on), for example, on the size of the distal end of the ulna bone of the wearer.

[0062] FIGS. 7 and 8 are additional perspective views of the device of FIG. 2 in accordance with some embodiments of the present invention.

[0063] FIG. 9 is a bottom view of the pulse oximeter of FIG. 2 in accordance with some embodiments of the present invention.

[0064] FIG. 10 is a top view of the pulse oximeter of FIG. 2 in accordance with some embodiments of the present invention.

[0065] FIG. 11 is another side view of the pulse oximeter of FIG. 2 in accordance with some embodiments of the present invention. In FIG. 11, the outermost part of the device casing is in phantom view to further illustrate the positioning of light source(s) **212**, detector **214**, and detector **216**.

[0066] FIGS. 12 and 13 are additional perspective views of the pulse oximeter of FIG. 2 in accordance with some embodiments of the present invention. In these figures, the outermost part of the device casing and the display **202** are in phantom view to further illustrate the positioning of light source(s) **212**, detector **214**, and detector **216**.

[0067] FIG. 14 is an exploded view showing various components of the pulse oximeter of FIG. 2 in accordance with some embodiments of the present invention. As shown, in some embodiments, the casing (referenced above as **210a**, **210b**, and **210c**) may include a first component **1402**, second

component **1404**, and third component **1406**. First component **1402** may be fixed to second component **1404** using one or more screws **1408** or other fixating devices. In some embodiments, third component **1406** (e.g., formed from an elastomer, for example, the same material as projection **208**) may be glued or otherwise affixed to second component **1406**. Component **1410** (e.g., formed from an elastomer, for example, the same material as projection **208**) may include various elements for housing light source(s) **212**, detector **214**, and detector **216**, where these elements of component **1410** that fit through corresponding openings in at least components **1404** and **1406**. Component **1410** may be encased on its other side by component **1402**.

[0068] FIG. 15 is a block circuit diagram illustrating hardware functionality of the pulse oximeter of FIG. 2 in accordance with some embodiments of the present invention. In general, in some embodiments, device **200** operates to generate red and infrared optic signals, which are used for heart rate and SPO2 measurements. To enable these and other features of device **200**, in some embodiments device **200** is capable of detection and measuring of incoming optic signals, movements detection, temperature sensing, signal processing, wireless transmission and receipt of data, visual display of at least heart rate, SPO2 and battery charge status, haptic alerts, battery operation, and power and battery management. FIG. 15 includes the following nine building blocks: analog front end (AFE) **1502**, microcontroller unit (MCU) **1504**, alerts transducers (haptic) **1506**, sensors (e.g., accelerometer, skin temperature and touch) **1508**, PPG sensors (e.g., LEDs and photo-diodes) **1510**, display panel **1512**, and wireless radio **1514** (e.g., Bluetooth), and power management circuit **1516**. The device may also include a user push-button or interface control for, for example, turning the device On/Off, navigating between screens, and/or reacting to the application requests. Additional details in accordance with various embodiments of the present invention are provided below.

[0069] In some embodiments, AFE block **1502** may be a fully-integrated analog front-end (AFE) suited for pulse oximeter applications. It may include a low-noise receiver channel with an integrated analog-to-digital converter (ADC), an LED transmit section, and diagnostics for sensor and LED fault detection. AFE block **1502** may be a configurable timing controller. This flexibility may enable the user to control the device timing characteristics. To ease clocking requirements and provide a low-jitter clock, an oscillator may also be integrated that functions from an external crystal. The AFE block **1502** may communicate to an external microcontroller or host processor using a suitable interface, such as, for example, an SPI™ interface.

[0070] The MCU block **1504** according to some embodiments of the present invention, with its attached memories, may be in charge of all the control and housekeeping tasks of device **200** as well as the SPO2 and heart rate signal processing and calculations. The MCU block **1504** may store and be configured to run one or more computer programs and/or applications. The computer instructions for such programs and/or applications may be stored in one or more non-transitory computer readable media of MCU block **1504**.

[0071] The alerts transducers **1506** according to some embodiments of the present invention may contain one or

more haptic transducers that provide haptic alerts whenever a fault is encountered or the wearer's SPO2 level goes below a certain level.

[0072] Sensors **1508** according to some embodiments of the present invention may include some or all of the following sensors: (i) accelerometer and gyroscope to provides movements and position data; (ii) skin temperature sensor to provide skin temperature data; and (iii) a touch sensor to detect if the device is attached to a wearer's wrist or not.

[0073] Display **1512** according to some embodiments of the present invention may be an OLED display (e.g., 96×96 pixels), and may display the calculated SPO2 and heart-rate as well as one or more status symbols and error messages.

[0074] Wireless radio **1514** according to some embodiments of the present invention may implement one or more suitable wireless communication functionalit(ies) (e.g., Bluetooth 4 (BLE) standard) and may be used to establish one or more communication channels between device **200** and, for example, a dedicated control and monitoring application (e.g., running on the wearer's mobile device such as a mobile phone) and/or a remote monitoring facility accessed via the internet or a cellular communications network.

[0075] Power and battery management block **1516** according to some embodiments of the present invention may accept a suitable battery (e.g., lithium-ion polymer battery), produce all necessary voltages, charge the battery, and monitor the battery condition.

[0076] FIG. **16** is a graph demonstrating the accuracy of pulse oximetry data produced by a pulse oximeter in accordance with FIG. **2** according to some embodiments of the present invention. As shown in FIG. **16**, there is a tight correlation (correlation=0.98; p-value<0.0001) between the pulse oximetry data (SPO2) derived from a device generally in accordance with FIG. **2** in some embodiments of the present invention and a reference functional arterial oxygen saturation (SaO2) determined by the average of 4 independent CO-oximeters measurements.

[0077] FIG. **17** is a graph demonstrating the accuracy of pulse rate data produced by a pulse oximeter in accordance with FIG. **2** according to some embodiments of the present invention. As shown in FIG. **17**, there is a tight correlation (correlation=0.98; p-value<0.0001) between the pulse rate (PR) derived from a device generally in accordance with FIG. **2** in some embodiments of the present invention and a reference heart rate (HR) determined by a standard electrocardiograph (ECG) device.

[0078] FIG. **18** is a graph of PPG signal quality by a pulse oximeter, for each of red and infrared light sources, in accordance with a device according to FIG. **2** in some embodiments of the present invention. The y-axis reflects the ratio of the alternating current (AC) to direct current (DC) portion of the signal, and the x-axis is time in seconds.

[0079] FIGS. **19A**, **19B**, **20A**, **20B**, **21A**, and **21B** illustrate embodiments of light source configurations for a wrist-worn pulse oximeter (e.g., configurations for light source(s) **212** of device **200** in FIG. **2**) according to some embodiments of the present invention. FIGS. **19A** and **19B** illustrate the light that passes through a dome-shaped lens (e.g., 4 or 5 mm dome-shaped lens) that is attached to a light emitting diode (LED) without space (FIG. **19A**) or with a 10 micrometer space between them (FIG. **19B**). As shown, the light rays are more concentrated when there is a space between the lens and the LED. Stray light is more prevalent when there is no space between the lens and LED.

[0080] FIGS. **20A** and **20B** illustrate configurations for a housing for light source(s) according to some embodiments of the present invention. As shown, in both FIGS. **20A** and **20B** the housing includes a raised inner ring **2002** and an outer ring **2004**. In some embodiments, the light source(s) (e.g., one or more LEDs) housed by the structure shown in FIGS. **20A** and **20B** may be placed generally within the area encompassed by inner ring **2002**. In various embodiments, the light source(s) may be positioned below, equal to, or above the height of inner ring **2002**.

[0081] In some embodiments, inner ring **2002** may have a height that is greater than zero but less than or equal to the height (h) of outer ring **2004**. For example, in some embodiments, the height of the outer ring **2004** may be between about 1 millimeter (mm) (or less), to about 15 mm (e.g., approximately 4 mm). The height of the inner ring **2002** may be between about 1 millimeter (mm) (or less) to about 15 mm (e.g., approximately 2 mm). For example, locating the base of inner ring **2002** at half the height of outer ring **2004** may reduce stray light by approximately 40%.

[0082] In some embodiments, the housing contains an inner ring **2002** but no outer ring **2004**. In some embodiments, inner ring **2002** may have a height of zero (i.e., no inner ring), in which case the light source(s) housed by the structure may be placed generally within the area encompassed by outer ring **2004**, and may be positioned in various embodiments below, equal to, or above the height of outer ring **2004**. In some embodiments, a housing is provided that does not contain inner ring **2002** nor outer ring **2004**.

[0083] FIGS. **21A** and **21B** each illustrate a configuration for a housing for light source(s) according to some embodiments of the present invention. They may be the same as or similar to the housing(s) shown in FIGS. **20A** and **20B**, respectively, albeit in side view. As shown, in both the FIGS. **21A** and **21B** embodiments the housing is generally conically-shaped and extends at an angle. When the angle was increased from about 56.5 degrees to about 59 degrees (an increase of about 2.5 degrees), stray light from the light source decreased by about 80%. In other embodiments, the housing may be at least partially cylindrically-shaped. In some embodiments, a maximal diameter of the housing (measured at the top of the housing at the outer ring) may be in a range of about 1 mm (or less) to about 30 mm, or from about 5 mm to about 20 mm (e.g., about 14 mm and making an angle of about 60 degrees). In some embodiments, the housing may cover adjacent detector(s) as well (e.g., but leaving an opening over the detector(s) as partially shown in FIGS. **21A** and **21B**). In some embodiments, a diameter of the inner ring may be about 1 mm (or less) to about 25 mm, or from about 5 mm to about 20 mm (e.g., about 8 mm).

[0084] FIGS. **22** and **23** illustrate housings for light source (s) and detector(s) according to some embodiments of the present invention. These housings may be embodiments of component **1410** (FIG. **14**), where the housings for the light source(s) and detector(s) are at least partially cylindrically-shaped. A front side of this component, which may be an insert for inclusion within a device (e.g., device **200**), where light is emitted from is shown in FIG. **22**. A rear side of this component is shown in FIG. **23**. In some embodiments, such housings may have the general dimensions (e.g., in terms of height(s) and diameter(s)) described above in connection with FIGS. **20A**, **20B**, **21A**, and **21B**. In some embodiments, the inner and outer rings of the housings form a spring-like configuration (e.g., resulting from their collective configu-

ration like a garmoshka and/or in other embodiments based on the inclusion of one or more springs). In some embodiments, the housings may be elastic, flexible, and spring-like for fixation to a wearer and/or to function as a damper to movement (artifacts) and to direct an optical axis of corresponding optical elements towards point 222 to maintain a transillumination and/or reflection configuration.

[0085] FIGS. 24 through 29 illustrate multiple views of a device (e.g., wrist-type pulse oximeter) in accordance with another embodiment of the present invention. For example, FIG. 24 illustrates that the device may measure and/or display data regarding SPO₂, pulse rate, Bluetooth status, notification (envelope icon) and battery charge level. In FIG. 26, an opening 2602 (e.g., the same as or similar to opening 226) for receipt or access of emergency medication (e.g., one or more pills) may be provided. In some embodiments, the device shown in FIGS. 24 through 29 may be the same as or similar to device 200 (FIG. 2) in all other respects.

[0086] A method of oximetry measurement, according to some embodiments of the invention, includes fixating a device at an area above a distal end of the ulna. This may be carried out, for example, through the use of projection 218, projection 208, and/or one or more dome-shaped projections of light source(s) 212, detector 214, and/or detector 216. Thereafter, one or more detectors at, adjacent to, or at a periphery of the fixated area may detect reflections of light by the distal end of the ulna, wherein the light was emitted by one or more (e.g., at least two) light sources having different wave lengths at, adjacent to, or at a periphery of the fixated area. In some embodiments, the detecting and emitting may be performed by detector(s) 214 and/or 216, and one or more emitter(s) 212, each having a different axis resulting from the manner in which each of them is angled generally toward a virtual center point 222 of the distal end of a wearer's ulna bone. In some embodiments, the method may further include blocking stray light from entering the fixated area, for example, by one or more projections 220. In some embodiments, the method may further comprise measuring a pulse by reflecting a coherent light source off a bone.

[0087] In the above description, an embodiment is an example or implementation of the invention. The various appearances of "one embodiment", "an embodiment" or "some embodiments" do not necessarily all refer to the same embodiments.

[0088] Although various features of embodiments of the present invention may be described in the context of a single embodiment, the features may also be provided separately or in any suitable combination. Conversely, although embodiments of the present invention may be described herein in the context of separate embodiments for clarity, the invention may also be implemented in a single embodiment.

[0089] Embodiments of the invention may include features from different embodiments disclosed above, and embodiments may incorporate elements from other embodiments disclosed above. The disclosure of elements of some embodiments of the invention in the context of a specific embodiment is not to be taken as limiting their use in the specific embodiment alone.

[0090] Furthermore, it is to be understood that embodiments of the invention can be carried out or practiced in various ways and that embodiments of the invention can be implemented in other ways than the ones outlined in the description above.

[0091] The invention is not limited to the diagrams or to the corresponding descriptions contained herein. For example, in a method according to some embodiments of the present invention, the flow need not move through each illustrated step or state, or in exactly the same order as described.

[0092] Meanings of technical and scientific terms used herein are to be commonly understood as by one of ordinary skill in the art to which the invention belongs, unless otherwise defined.

[0093] While this specification refers to a limited number of embodiments, these should not be construed as limitations on the scope of the invention, but rather as exemplifications of some of the preferred embodiments. Other possible variations, modifications, and applications are also within the scope of embodiments of the present invention.

1. A pulse oximetry device, the device comprising:
 - at least two light sources having different wavelengths;
 - at least one detector responsive to said different wavelengths;
 - a wrist strap; and
 - a casing coupled to the wrist strap for housing the at least two light sources and the at least one detector;
 wherein the wrist strap comprises a generally concave projection adapted to fit snugly against a wearer's wrist and remain in place even when the wearer is moving.
2. The pulse oximetry device of claim 1, wherein the generally concave projection further comprises one or more ridges.
3. The pulse oximetry device of claim 1, wherein the generally concave projection comprises an elastomer material having a softness (durometer) of between 30 to 75 Shore A.
4. The pulse oximetry device of claim 1, wherein the generally concave projection comprises a silicon elastomer material having a softness (durometer) of approximately 50 Shore A.
5. The pulse oximetry device of claim 1, wherein the generally concave projection comprises a hollow interior portion for receipt of medication.
6. The pulse oximetry device of claim 1, wherein the wrist strap comprises:
 - a first portion that comprises the generally concave projection; and
 - a second portion adapted for attachment to the first portion for fixating the wrist strap around a user's wrist, and wherein the second portion comprises a second projection that assists to fixate the device at a fixated area corresponding to a distal end of the wearer's ulna bone.
7. The pulse oximetry device of claim 6, wherein the second projection is a curved projection that generally follows a contour of the wearer's ulna bone.
8. The pulse oximetry device of claim 7, wherein the second projection is formed generally in the shape of part of a dome or sphere.
9. The pulse oximetry device of claim 1, wherein each of the at least two light sources and the at least one detector is positioned within the casing such that when the wrist strap is affixed around the wearer's wrist the at least two light sources and the at least one detector are positioned adjacent to the distal end of the ulna and closer to the ulna than the radius, and the at least one detector is positioned to detect light emitted from the at least two light sources.

10. A pulse oximetry device, the device comprising:
at least two light sources having different wavelengths;
at least one detector responsive to said different wavelengths;
a wrist strap; and
a casing coupled to the wrist strap for housing the at least two light sources and the at least one detector;
wherein each of the at least two light sources and the at least one detector is angled generally toward a virtual center point of the distal end of a wearer's ulna bone and each of the at least two light sources and the at least one detector has a different axis.

11. The pulse oximetry device of claim **10**, wherein each of the at least two light sources and the at least one detector is positioned within the casing such that when the wrist strap is affixed around the wearer's wrist the least two light sources and the at least one detector are positioned adjacent to the distal end of the ulna and closer to the ulna than the radius, and the at least one detector is positioned to detect light emitted from the at least two light sources.

12. The pulse oximetry device of claim **10**, wherein at least one of the at least two light sources and the at least one detector comprises a generally dome-shaped or conical-shaped structure that assists to fixate the pulse oximetry device, and its corresponding at least two light source(s) and at least one detector, at a fixated area corresponding to a distal end of a wearer's ulna bone.

13. A pulse oximetry device, the device comprising:
at least two light sources having different wavelengths;
at least one detector responsive to said different wavelengths;
a wrist strap; and
a casing coupled to the wrist strap for housing the at least two light sources and the at least one detector;
wherein the casing comprises a first portion and a second portion that extend at an angle relative to each other, with a display fixed to the first portion and the at least two light sources and the at least one detector fixed to the second portion.

14. The pulse oximetry device of claim **13**, wherein the first portion of the casing and the second portion of the casing together are generally "L" shaped.

15. The pulse oximetry device of claim **13**, wherein the casing is strong enough to maintain the positioning of the at least two light sources and the at least one detector when the device is worn by a wearer, while simultaneously having slight pliability or elasticity to act as a movement dampening cushion that reduces measurement artifacts of the pulse oximetry device resulting from movement of the wearer.

16. The pulse oximetry device of claim **15**, wherein the casing comprises a third portion that joins the first portion and the second portion of the casing, where the third portion allows for slight angular movement between the first portion and the second portion of the casing in response to normal forces while the pulse oximetry device is being worn by a user.

17. The pulse oximetry device of claim **13**, wherein the casing comprises aluminum or thermoplastic urethane (TPU).

18. The pulse oximetry device of claim **17**, wherein the casing has a durometer of between 25 Shore A and 35 Shore A.

19. The pulse oximetry device of claim **13**, wherein each of the at least two light sources and the at least one detector is positioned within the casing such that when the wrist strap is affixed around the wearer's wrist the least two light sources and the at least one detector are positioned adjacent to the distal end of the ulna and closer to the ulna than the radius, and the at least one detector is positioned to detect light emitted from the at least two light sources.

20. The pulse oximetry device of claim **1**, further comprising a pad that is mounted or otherwise fixed generally to an inner side of the casing, wherein said pad comprises one or more barriers that function to fit snugly against a wearer's wrist and prevent stray light from entering a measuring area of the at least two light sources and the at least one detector when the pulse oximetry device is worn by a wearer.

21.-25. (canceled)

* * * * *

专利名称(译)	手腕传感器脉搏血氧仪和方法		
公开(公告)号	US20200015723A1	公开(公告)日	2020-01-16
申请号	US16/468045	申请日	2017-12-15
[标]申请(专利权)人(译)	奥希顿医疗有限公司		
申请(专利权)人(译)	OXITONE MEDICAL LTD.		
当前申请(专利权)人(译)	OXITONE MEDICAL LTD.		
[标]发明人	EISEN LEON BEN ZION UZI GIL KOBY REFAEL HARPAK OFER SHAHAM AVI		
发明人	EISEN, LEON BEN-ZION, UZI GIL, KOBY REFAEL HARPAK, OFER SHAHAM, AVI		
IPC分类号	A61B5/1455 A61B5/00		
CPC分类号	A61B5/6831 A61B5/681 A61B5/6824 A61B5/02427 A61B5/14552 A61B2562/185 A61B5/6834		
优先权	62/438501 2016-12-23 US		
外部链接	Espacenet USPTO		

摘要(译)

提供了一种脉搏血氧饱和度测定装置，其通常固定在使用者的手腕周围。该装置可以包括一个或多个机械特征，其将装置固定在例如穿戴者的尺骨的远端。该设备可以包括由合适的材料（例如，诸如硅的弹性体）形成的一个或多个突起，这些突起使得该设备紧密地贴合在佩戴者的手腕上并且即使在佩戴者移动时也保持在适当的位置，从而减少了检测到的信号中的运动伪像。通过设备。该设备可以包括一个或多个机械特征或散热片，以减少测量区域中的环境光或杂散光。该装置可以包括一个或多个检测器以及一个或多个光源，每个具有不同的轴，这是由于每个轴都朝向穿用者尺骨的远端的虚拟中心点成角度的。

