



US 20180168491A1

(19) **United States**

(12) **Patent Application Publication**
Al-Ali et al.

(10) **Pub. No.: US 2018/0168491 A1**
(43) **Pub. Date: Jun. 21, 2018**

(54) **REGIONAL OXIMETRY SENSOR**

A61B 5/1455 (2006.01)
H01R 13/52 (2006.01)

(71) Applicant: **MASIMO CORPORATION**, Irvine, CA (US)

(52) **U.S. Cl.**
CPC *A61B 5/14542* (2013.01); *H01R 13/5224* (2013.01); *A61B 5/14552* (2013.01); *A61B 5/14553* (2013.01); *A61B 5/1455* (2013.01); *A61B 5/6833* (2013.01); *A61B 5/7275* (2013.01); *A61B 5/742* (2013.01); *A61B 5/14551* (2013.01); *A61B 5/14557* (2013.01); *A61B 2562/22* (2013.01); *A61B 2562/222* (2013.01); *A61B 2562/225* (2013.01); *A61B 2562/227* (2013.01); *A61B 2562/228* (2013.01); *H01R 2201/12* (2013.01); *A61B 5/746* (2013.01)

(72) Inventors: **Ammar Al-Ali**, San Juan Capistrano, CA (US); **Kevin Forrest**, Rancho Santa Margarita, CA (US); **Yassir Abdul-Hafiz**, Irvine, CA (US); **Walter M. Weber**, Laguna Hills, CA (US); **Pete Mangosing**, Santa Ana, CA (US); **Sujin Hwang**, Irvine, CA (US)

(21) Appl. No.: **15/891,910**

(22) Filed: **Feb. 8, 2018**

Related U.S. Application Data

- (63) Continuation of application No. 14/507,620, filed on Oct. 6, 2014.
- (60) Provisional application No. 62/012,170, filed on Jun. 13, 2014, provisional application No. 61/887,878, filed on Oct. 7, 2013, provisional application No. 61/887,856, filed on Oct. 7, 2013, provisional application No. 61/887,883, filed on Oct. 7, 2013.

Publication Classification

(51) **Int. Cl.**
A61B 5/145 (2006.01)
A61B 5/00 (2006.01)

(57) **ABSTRACT**

A regional oximetry sensor has a sensor head attachable to a patient skin surface so as to transmit optical radiation into the skin and receive that optical radiation after attenuation by blood flow within the skin. The sensor includes windows that press into the skin to maximize optical transmission. A stem extending from the sensor head transmits electrical signals between the sensor head and an attached cable. In a peel resistant configuration, the stem is terminated interior to the sensor head and away from a sensor head edge so as to define feet along either side of the stem distal the stem termination. The stem interior termination transforms a peel load on a sensor head adhesive to less challenging tension and shear loads on the sensor head adhesive.

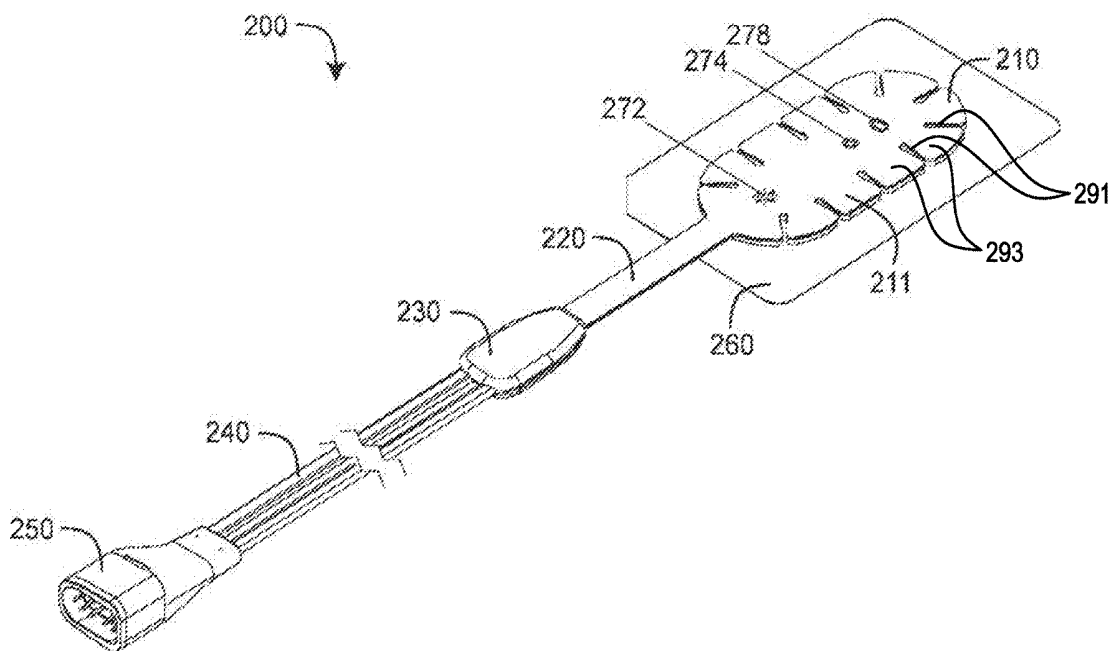

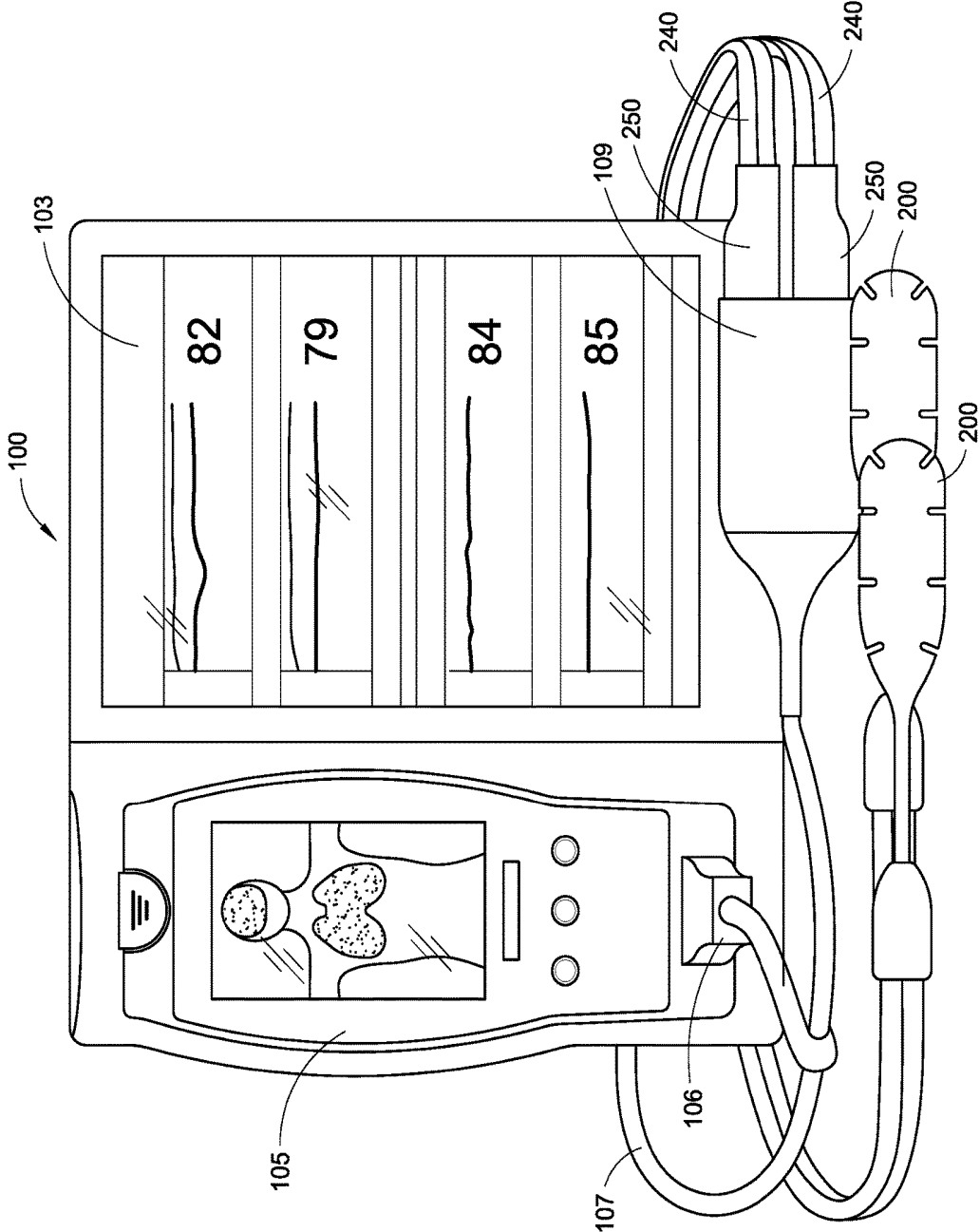

FIG. 1

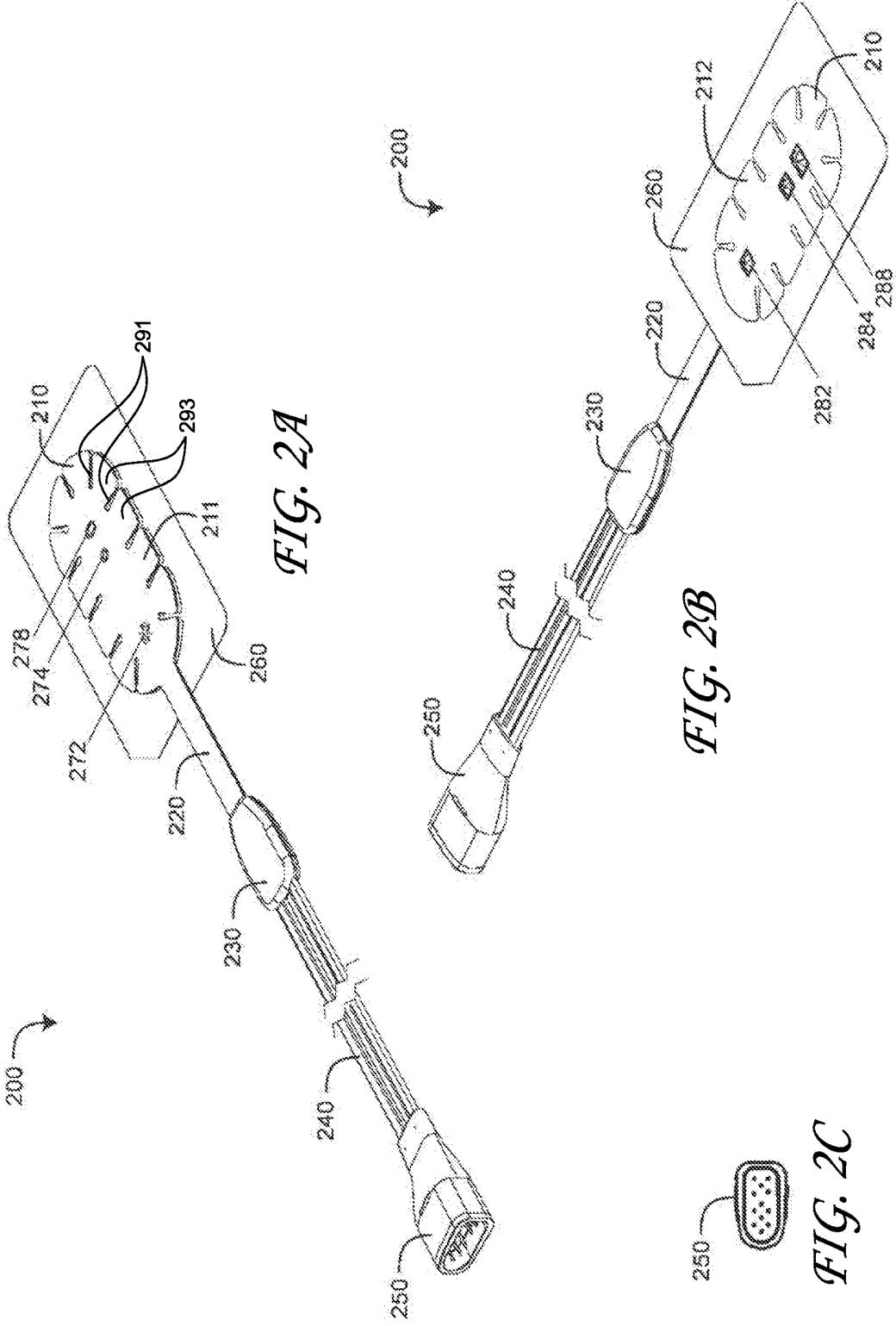

FIG. 2A

FIG. 2B

FIG. 2C

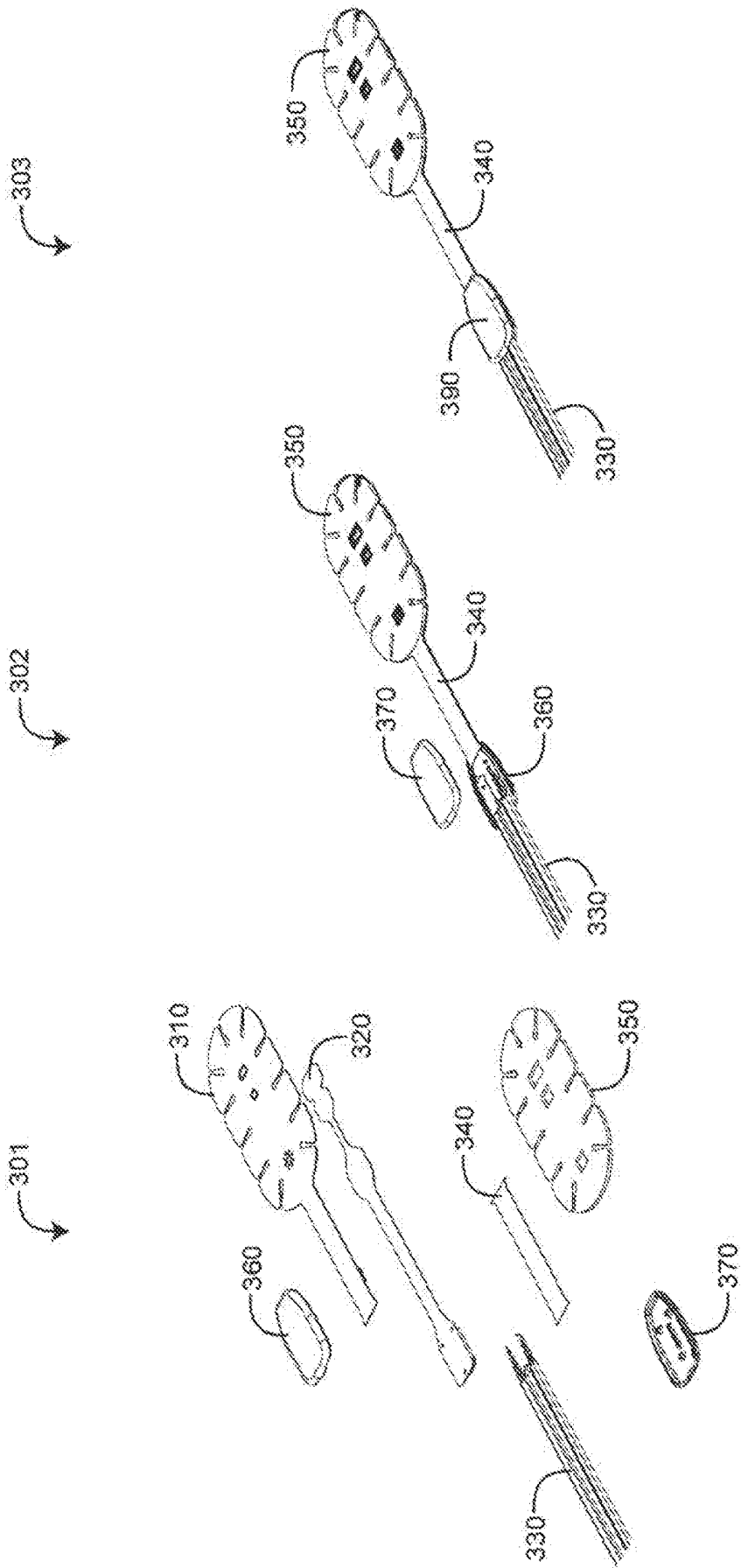

FIG. 3A

FIG. 3B

FIG. 3C

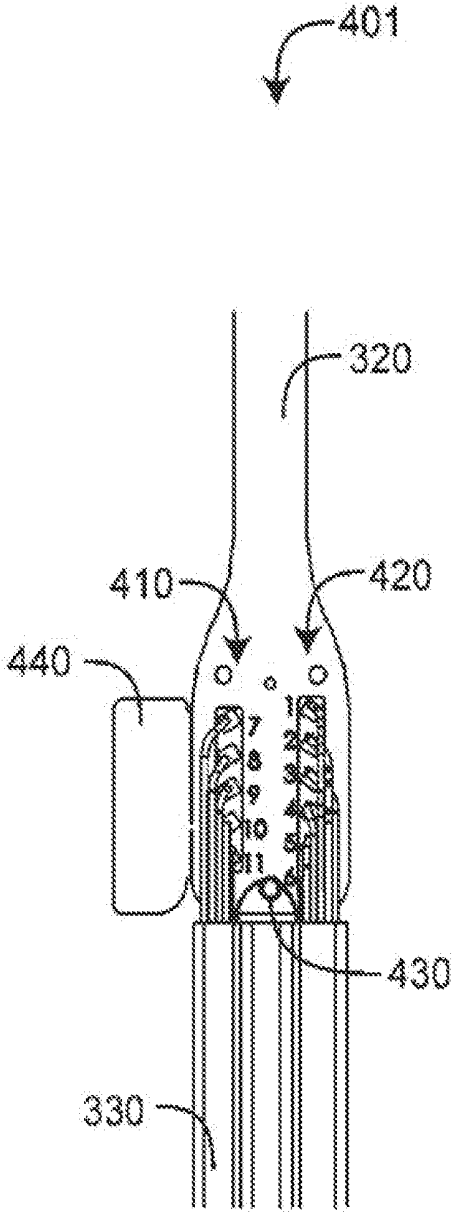

FIG. 4

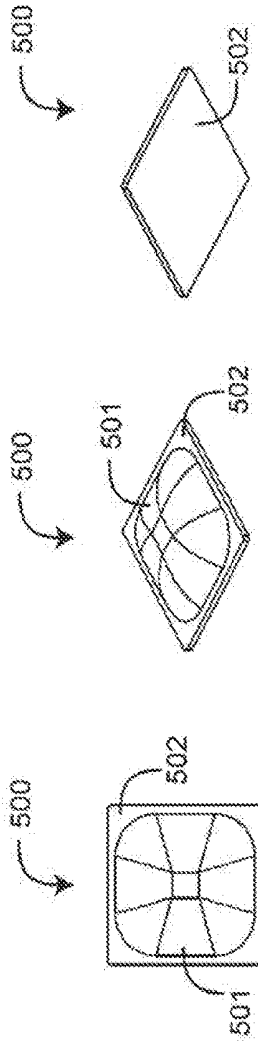

FIG. 5A

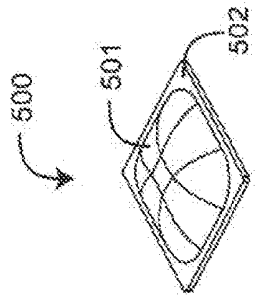

FIG. 5B

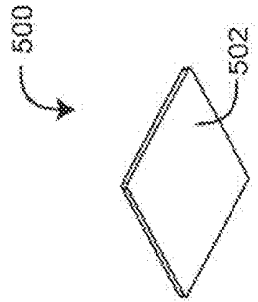
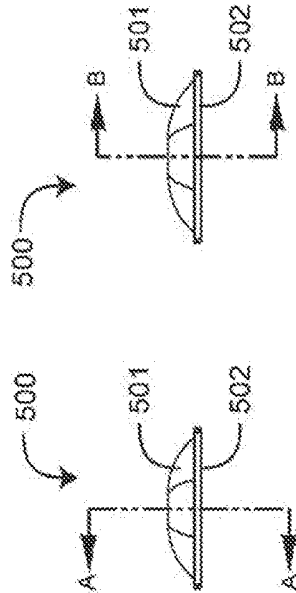
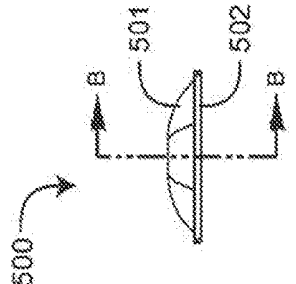

FIG. 5C



SECTION A-A

FIG. 5D



SECTION B-B

FIG. 5E

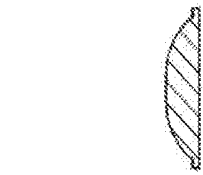

FIG. 5F

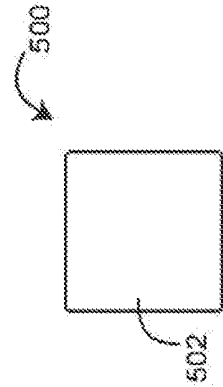

FIG. 5G

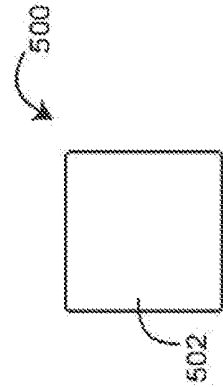

FIG. 5H

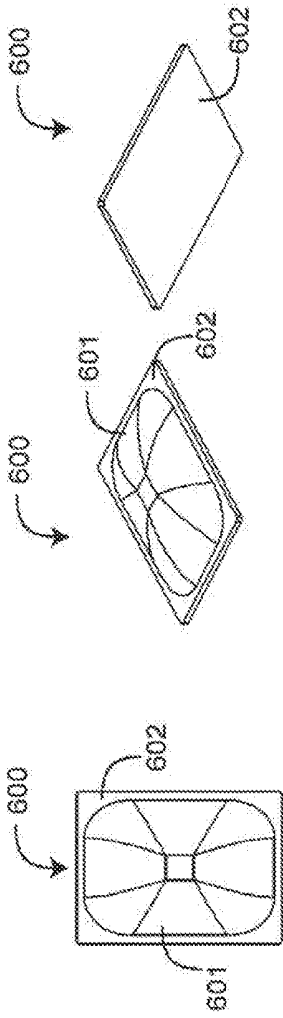

FIG. 6A

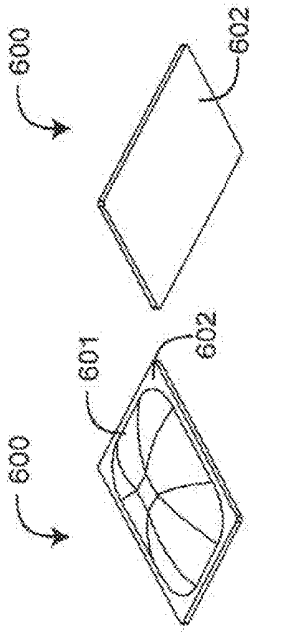

FIG. 6B

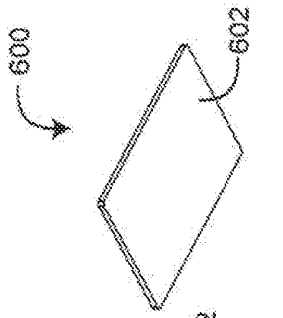

FIG. 6C

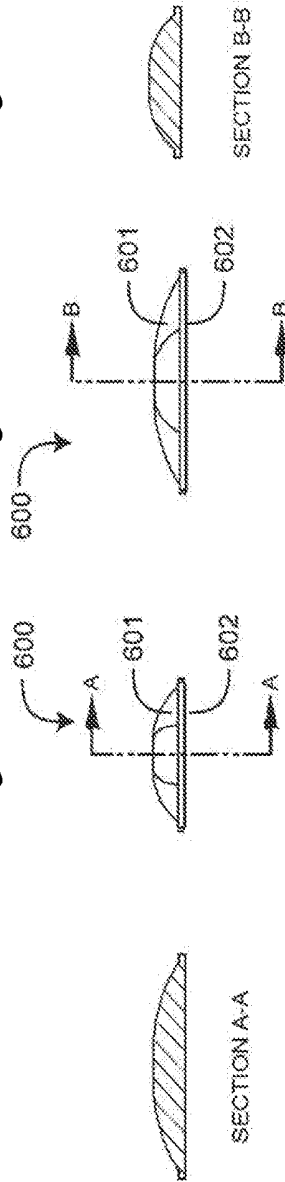

FIG. 6E

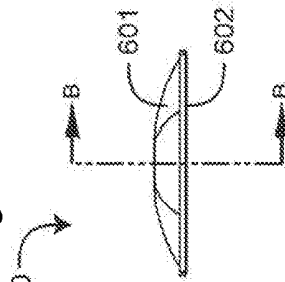

FIG. 6G

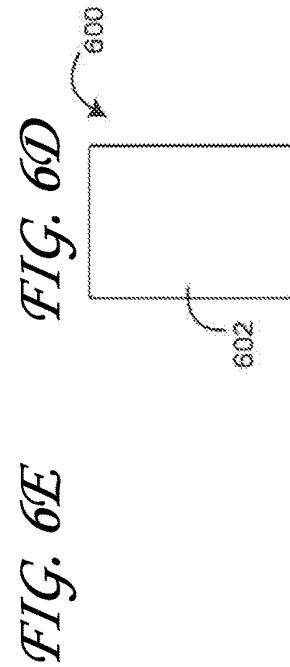

FIG. 6E

FIG. 6D

FIG. 6F

FIG. 6G

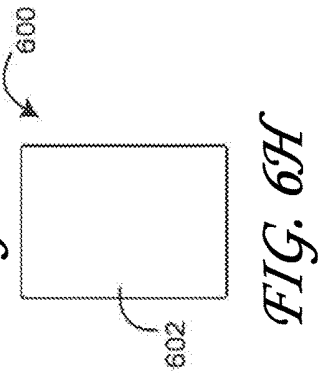

FIG. 6H

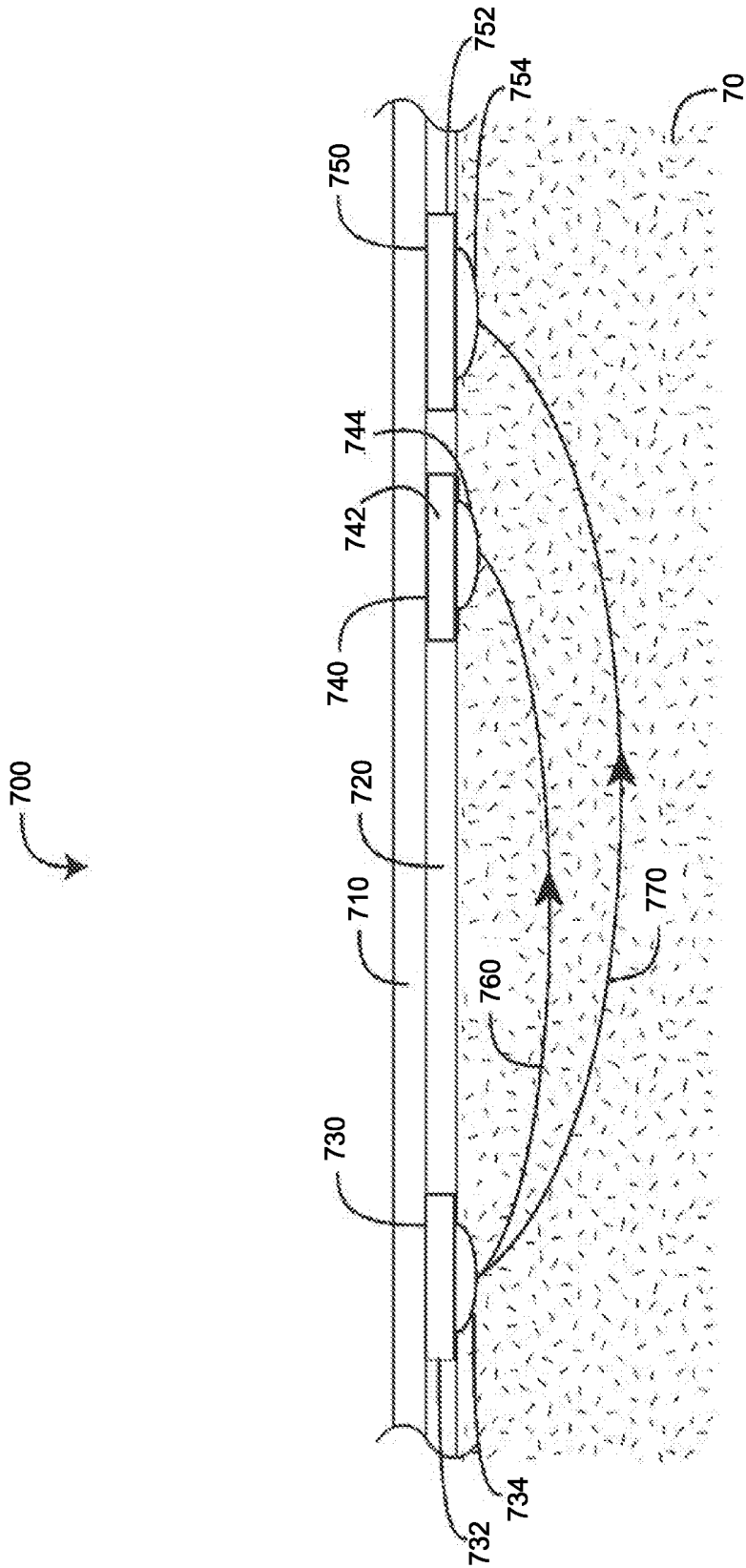

FIG. 7

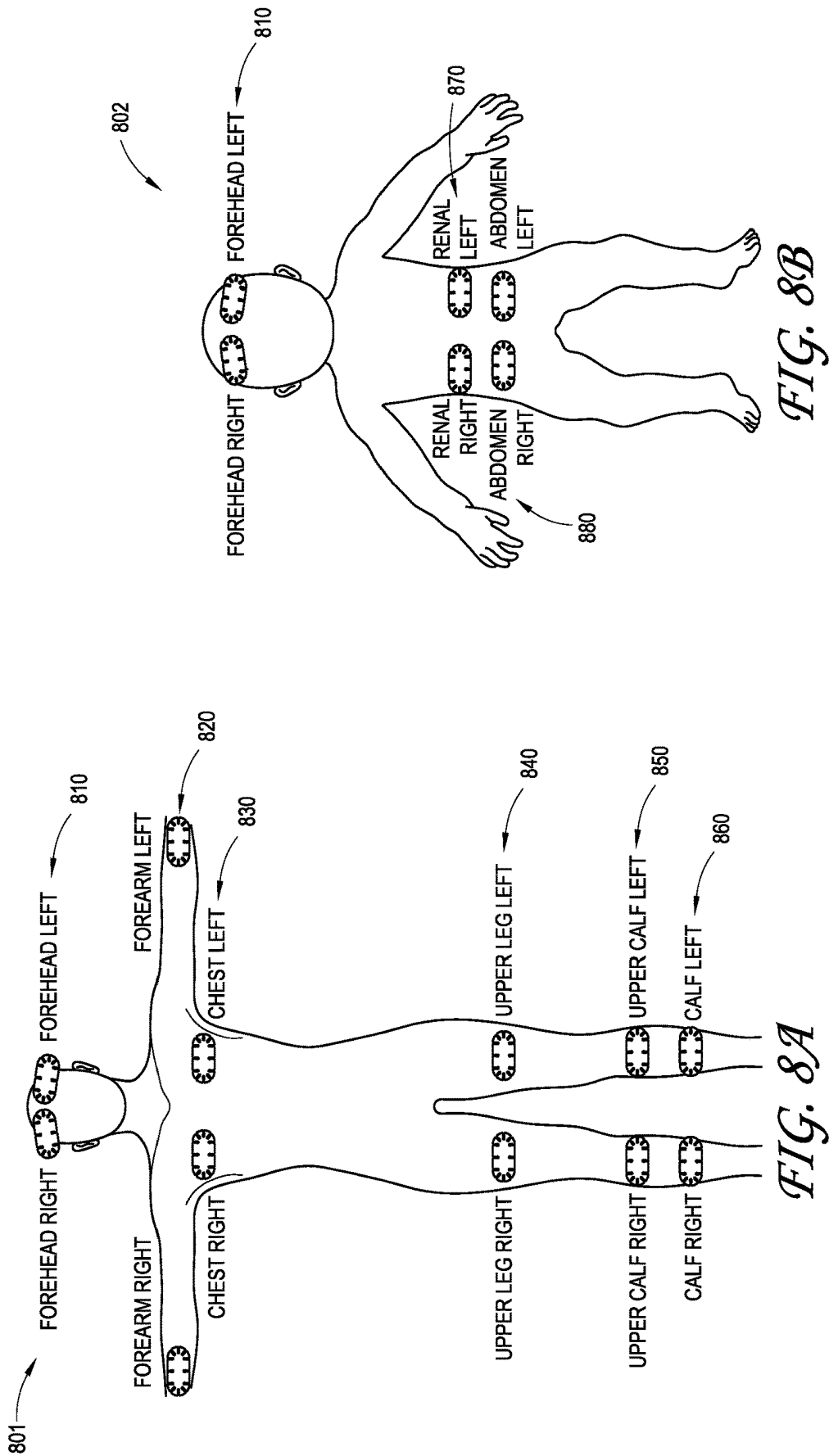

FIG. 8B

FIG. 8A

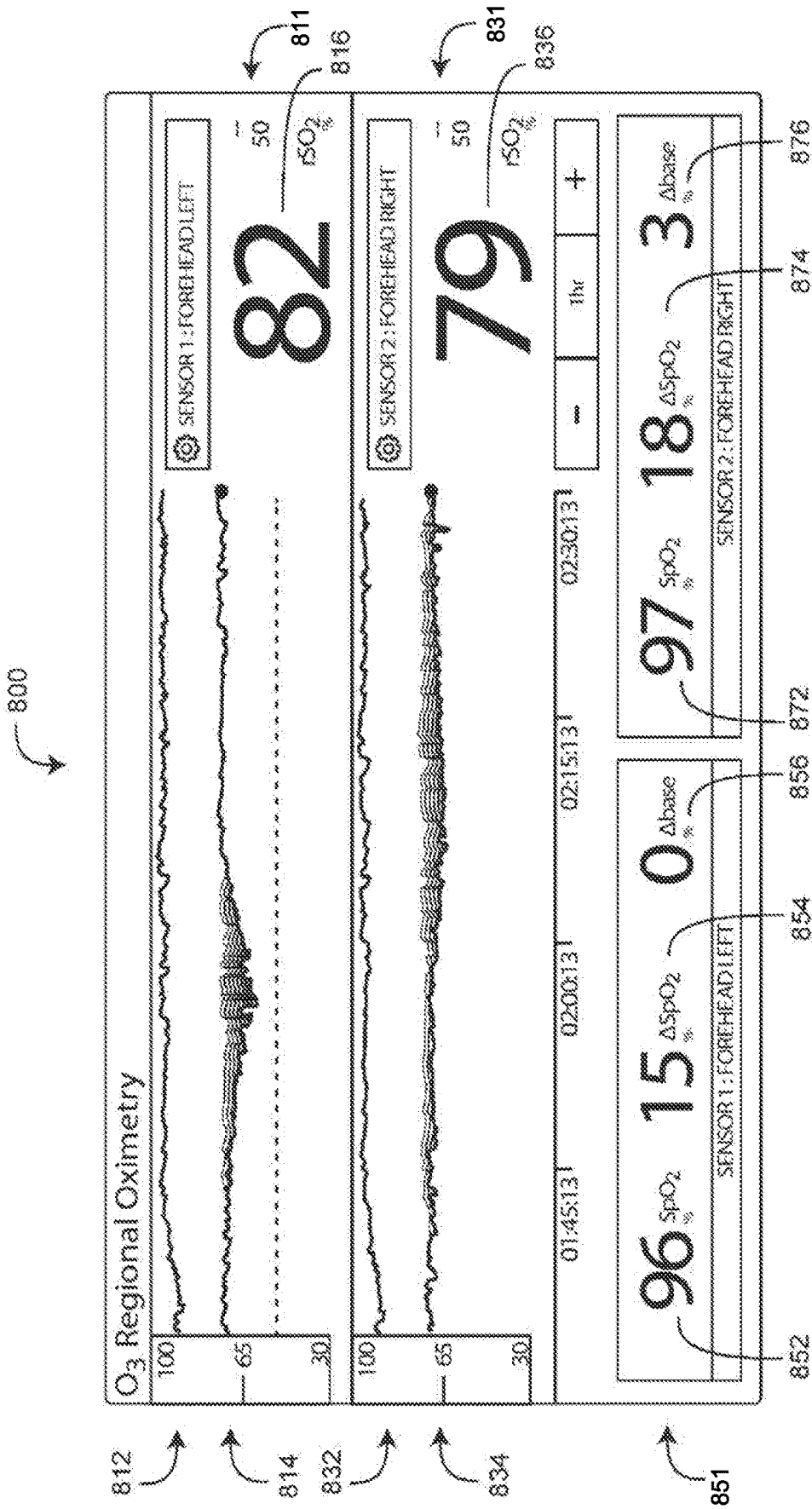

FIG. 8C

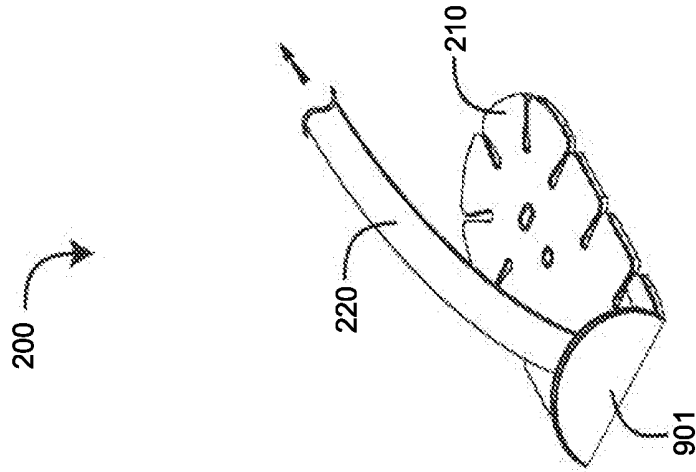

FIG. 9A

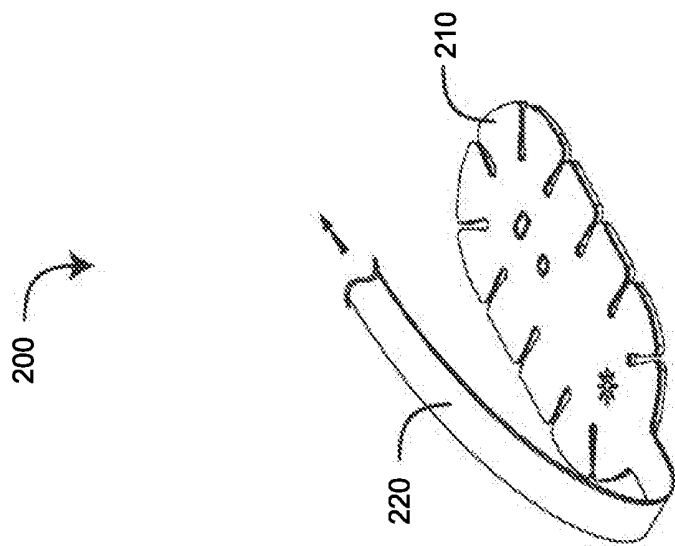

FIG. 9B

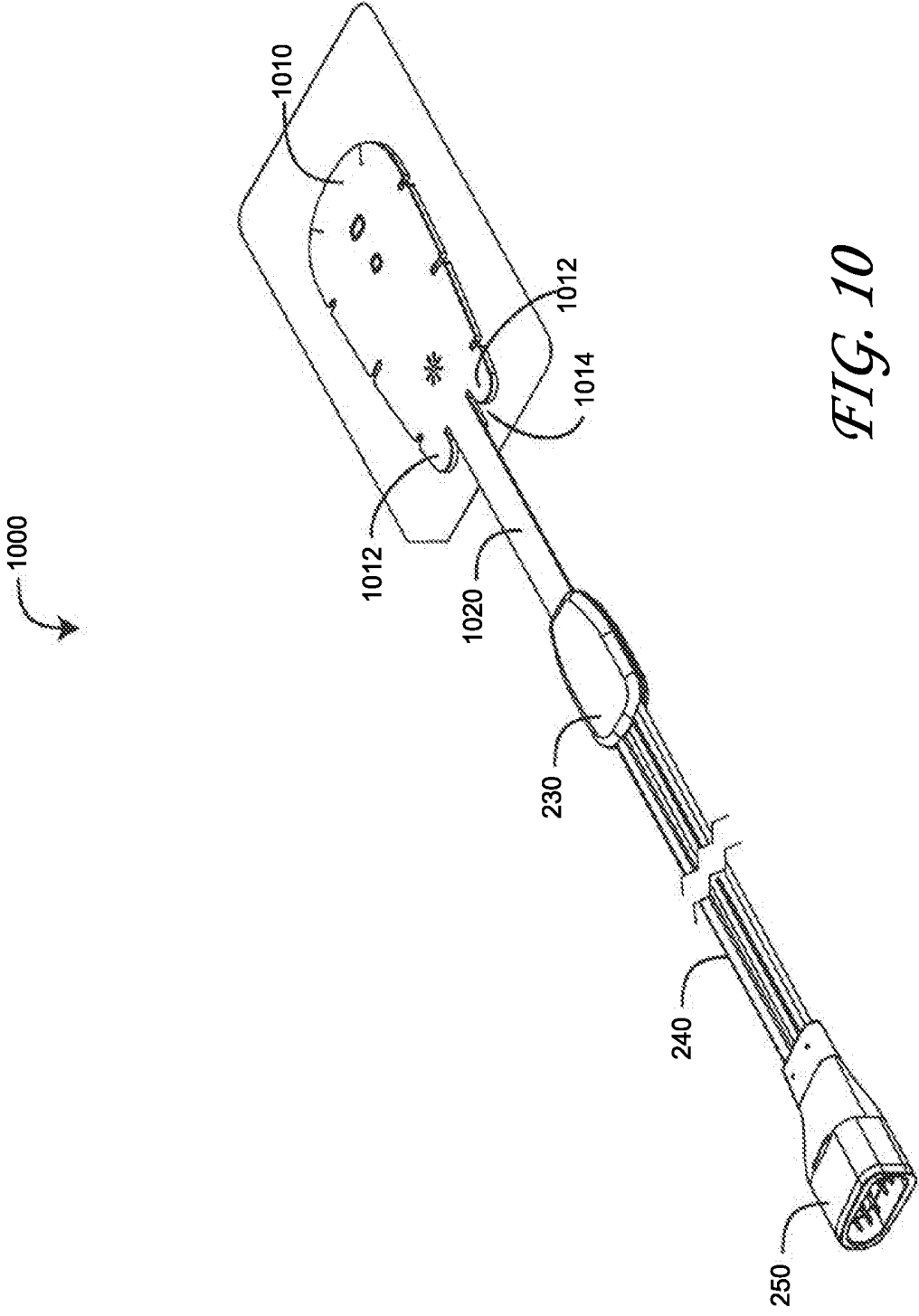

FIG. 10

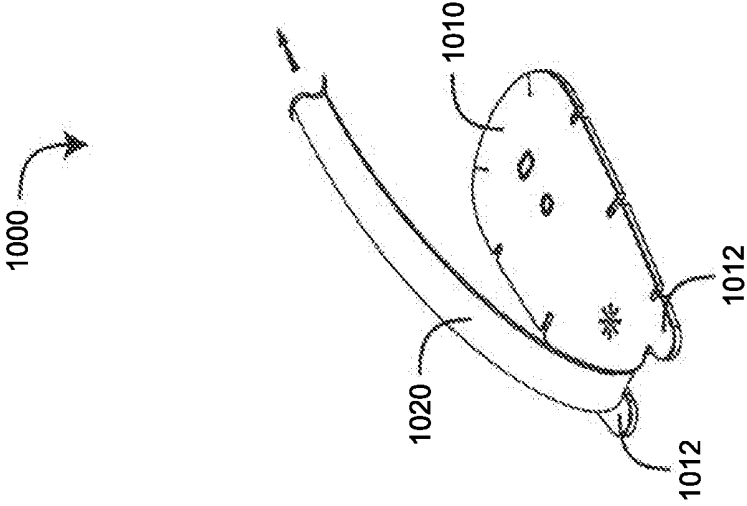

FIG. 11B

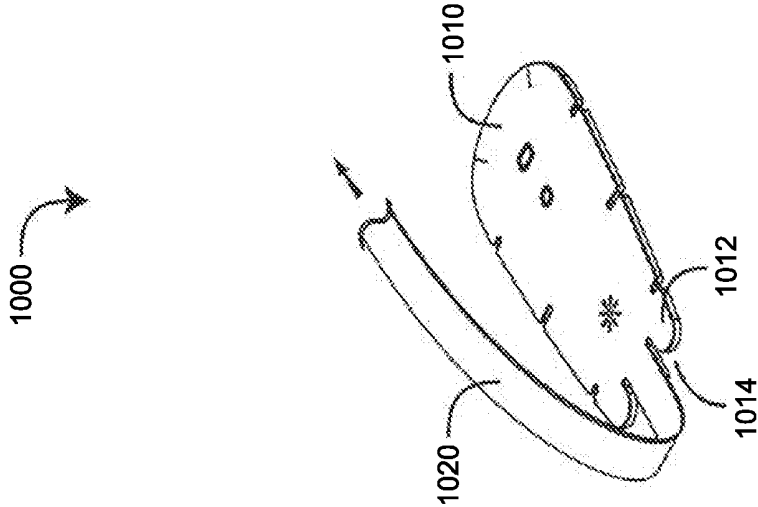
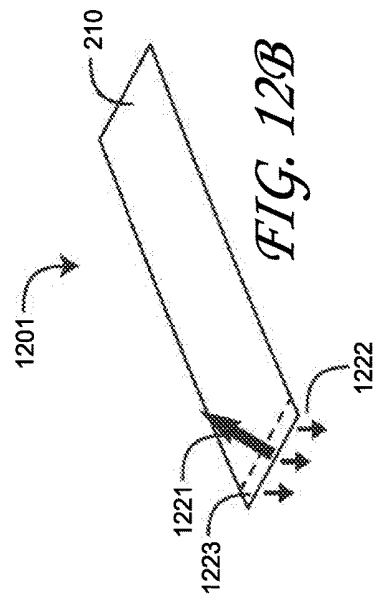
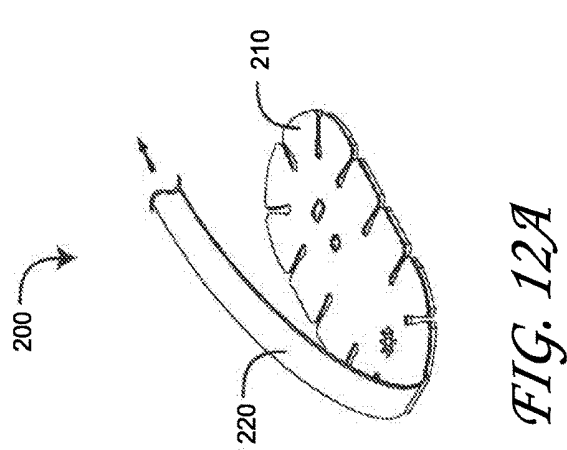
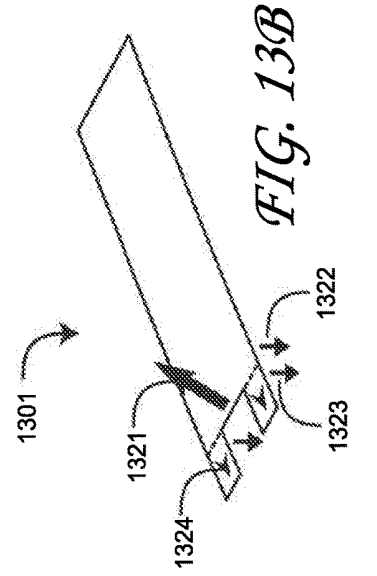
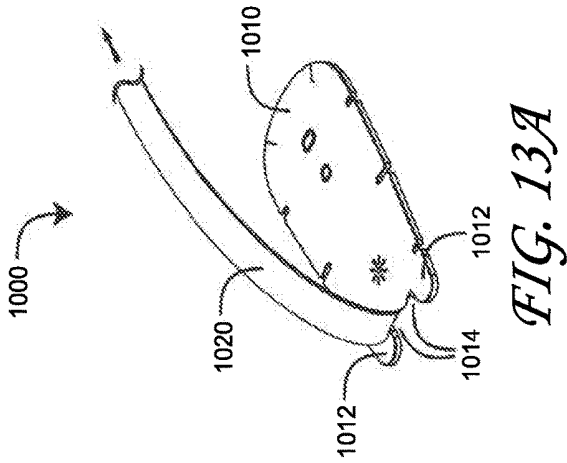

FIG. 11A



REGIONAL OXIMETRY SENSOR

INCORPORATION BY REFERENCE TO ANY PRIORITY APPLICATIONS

[0001] Any and all applications for which a foreign or domestic priority claim is identified in the Application Data Sheet as filed with the present application are hereby incorporated by reference under 37 CFR 1.57. The present application is a continuation of U.S. patent application Ser. No. 14/507,620, filed Oct. 6, 2014, titled Regional Oximetry Sensor, which claims priority benefit under 35 U.S.C. § 119(e) to U.S. Provisional Patent Application Ser. No. 62/012,170, filed Jun. 13, 2014, titled Peel-Off Resistant Regional Oximetry Sensor; U.S. Provisional Patent Application Ser. No. 61/887,878 filed Oct. 7, 2013, titled Regional Oximetry Pod; U.S. Provisional Patent Application Ser. No. 61/887,856 filed Oct. 7, 2013, titled Regional Oximetry Sensor; and U.S. Provisional Patent Application Ser. No. 61/887,883 filed Oct. 7, 2013, titled Regional Oximetry User Interface; all of the above-referenced provisional patent applications are hereby incorporated in their entireties by reference herein.

FIELD

[0002] The present disclosure relates to the field of optical based physiological sensors.

BACKGROUND

[0003] Regional oximetry, also referred to as tissue oximetry and cerebral oximetry, enables the continuous assessment of the oxygenation of tissue. The measurement is taken by placing one or more sensors on a patient, frequently on the patient's left and right forehead. Regional oximetry estimates regional tissue oxygenation by transcutaneous measurement of areas that are vulnerable to changes in oxygen supply and demand. Regional oximetry exploits the ability of light to penetrate tissue and determine hemoglobin oxygenation according to the amount of light absorbed by hemoglobin.

[0004] Regional oximetry differs from pulse oximetry in that tissue sampling represents primarily (70-75%) venous, and less (20-25%) arterial blood. The technique uses two photo-detectors with each light source, thereby allowing selective sampling of tissue beyond a specified depth beneath the skin. Near-field photo-detection is subtracted from far-field photo-detection to provide selective tissue oxygenation measurement beyond a pre-defined depth. Moreover, regional oximetry monitoring does not depend upon pulsatile flow.

[0005] Regional oximetry is a useful patient monitoring technique to alert clinicians to dangerous clinical conditions. Changes in regional oximetry have been shown to occur in the absence of changes in arterial saturation or systemic hemodynamic parameters.

SUMMARY

[0006] The present disclosure provides a regional oximetry sensor. The regional oximetry sensor includes, for example, a face tape layer and a base tape layer adhesively attachable to a patient skin surface. The regional oximetry sensor also includes at least one emitter configured to transmit optical radiation into the patient skin surface, a near-field detector configured to detect the optical radiation

after attenuation by tissue of the patient and a far field detector also configured to detect the optical radiation after attenuation by tissue of the patient. In an embodiment, the regional oximetry sensor also includes one or more focus elements associated with one or more of the emitter, the near-field detector and the far field detector. In an embodiment any or all of the emitter, near-field detector and far field detector can be provided with a focus element. The focus element improves optical transmissions by gently pushing into the skin and providing improved optical coupling with the skin.

[0007] The focus element can include a half-dome shape or any three dimensional shape that gently pushes into the skin to improve optical coupling. The focus element can also have a rectangular planar base in order to provide a support structure for cooperating with the face tape layer and/or other portions of the regional oximetry sensor. In an embodiment, the focus element associated with the near-field detector is smaller than the focus element associated with the far field detector. For example, the near field detector includes a square shape whereas the far field detector includes a larger rectangular shape.

[0008] In an embodiment of the regional oximetry sensor, the regional oximetry sensor can have a face tape layer and a base tape layer adhesively attachable to a patient skin surface as discussed above. The sensor can also have at least one emitter configured to transmit optical radiation into the patient skin surface, a near-field detector configured to detect the optical radiation after attenuation by tissue of the patient, and a far field detector also configured to detect the optical radiation after attenuation by tissue of the patient. In some embodiments, the face tape layer and the base tape layer include a plurality of notches forming a plurality of cutouts. The plurality of cutouts can be formed in a portion of a periphery or across the entire periphery of the base and face tape layers, for example. The cutouts are mechanically decoupled from each other. Due to the mechanical decoupling, the cutouts allow for greater ease of patient movement of the measurement site. This reduces patient discomfort while wearing the regional sensor.

[0009] In an embodiment, a peel-off resistant regional oximetry sensor is disclosed. The peel-off resistant regional oximetry sensor includes a head attachable to a patient skin surface and configured to transmit optical radiation into the skin and receive that optical radiation after attenuation by blood flow within the skin and a stem extending from the sensor head and configured to transmit electrical signals between the sensor head and an attached cable. The stem is terminated interior to the sensor head and away from an edge of the sensor head so as to define feet along either side of the stem distal the stem termination.

BRIEF DESCRIPTION OF THE DRAWINGS

[0010] The drawings and following associated descriptions are provided to illustrate embodiments of the present disclosure and do not limit the scope of the claims. Corresponding numerals indicate corresponding parts, and the leading digit of each numbered item indicates the first figure in which an item is found.

[0011] FIG. 1 is a depiction of a patient monitoring system including regional oximetry sensors and a processing and display unit.

[0012] FIGS. 2A-C are top and bottom perspective views and a connector-end view, respectively, of a regional oximetry sensor;

[0013] FIGS. 3A-C are top exploded, bottom partially-exploded and bottom assembled perspective views, respectively, of regional oximetry sensor head, stem and shell assemblies;

[0014] FIG. 4 is a bottom plan view a sensor cable and sensor flex circuit interconnection;

[0015] FIGS. 5A-H are a top plan view, top and bottom perspective views, first side and first side cross-sectional views, second side and second side cross-sectional views and a bottom view, respectively, of a near-field detector lens;

[0016] FIGS. 6A-H are a top plan view, top and bottom perspective views, first side and first side cross-sectional views, second side and second side cross-sectional views and a bottom view, respectively, of a far-field detector lens;

[0017] FIG. 7 is a cross-sectional view of a regional oximetry sensor attached to a tissue site and corresponding near-field and far-field emitter-to-detector optical paths;

[0018] FIGS. 8A-B are a regional oximetry monitor display of sensor placement options for an adult and a child, respectively; and

[0019] FIG. 8C is an exemplar regional oximetry monitor display using two regional sensors.

[0020] FIGS. 9A-B are top perspective views of a regional oximetry sensor being inadvertently peeled from a skin-surface monitoring-site due to a pulling force applied to the sensor stem and interconnecting sensor cable;

[0021] FIG. 10 is a top perspective view of a peel-off resistant regional oximetry sensor;

[0022] FIGS. 11A-B are top perspective views of a peel-off resistant regional oximetry sensor adhering to a skin-surface monitoring site despite a pulling force applied to the sensor stem and interconnecting sensor cable; and

[0023] FIGS. 12A, 12B, 13A and 13B are side-by-side, top perspective views of a regional oximetry sensor and a peel-off resistant regional oximetry sensor subjected to like pulling forces and the corresponding impact of anti-peel feet extending from the cable-side of the peel-off resistant regional oximetry sensor.

DETAILED DESCRIPTION

[0024] Aspects of the disclosure will now be set forth in detail with respect to the figures and various embodiments. One of skill in the art will appreciate, however, that other embodiments and configurations of the devices and methods disclosed herein will still fall within the scope of this disclosure even if not described in the same detail as some other embodiments. Aspects of various embodiments discussed do not limit the scope of the disclosure herein, which is instead defined by the claims following this description.

[0025] FIG. 1 is a physiological monitoring system 100 configured to measure and display regional oximetry measurements. The physiological monitoring system 100 includes at least a display 103 and a processor (not shown) for processing and displaying physiological measurements. The physiological monitoring system 100 also includes at least one sensor 200 for detecting physiological information and providing that physiological information to the processor of the physiological monitoring system 100. In the embodiment of FIG. 1, the physiological monitoring system includes a removable hand held physiological monitor 105. The physiological monitoring system 100 of FIG. 1 also

includes a sensor cable system 106 that includes wiring 107 and a sensor connector 109. Sensor connector 109 includes ports for two or more sensors. The sensors are described in more detail with respect to FIGS. 2A-2C.

[0026] FIGS. 2A-C illustrate a regional oximetry sensor 200 embodiment having a sensor head 210, stem 220, shell 230, cable 240 and connector 250. The sensor head 210 houses an emitter 282, a near-field detector 284 and a far-field detector 288 within a layered tape having a top side 211 and an adhesive bottom side 212 disposed on a release liner 260. The release liner 260 is removed so as to adhere the bottom side 212 to a skin surface. The sensor head 210 also includes notches or channels 291 that form cutouts 293. The cutouts 293 are independently flexible from other neighboring cutouts. Because of the various placement locations of the sensors on the human body and the movement forces placed on regional oximetry sensors, the cutouts 293 allow the sensor head 210 to be relatively large to increase the measurement area and adhesive surface area without greatly inhibiting patient movement. Thus, for example, when a patient moves their forehead with a sensor 200 adhesively attached, the sensor allows for some movement of the underlying skin so that the patient is more comfortable, yet provide a large enough surface area to provide good measurement and adhesive qualities.

[0027] The regional oximetry sensor 200 is substantially flat, allowing the sensor to adhere to the patient without significant bulges. The stem 220 extends out radially outward from the sensor head 210. The stem is positioned to extend from a radial edge in order to provide a clean exit from the body for wiring and cables. The radial placement also provides for streamlined sensor construction and prevents unnecessary bending or wrapping of internal or external wires.

[0028] The emitter 282 and detectors 284, 288 have a lens that protrudes from the bottom side 212, advantageously providing a robust optics-skin interface. The top side 211 has emitter/detector indicators 272-278 so as to aid precise sensor placement on a patient site. The shell 230 houses the stem 220 to cable 240 interconnect, described in detail with respect to FIGS. 3A-C, below. The connector 250 is a 12-pin, D-shaped plug.

[0029] FIGS. 3A-C illustrate an assembly of a regional oximetry sensor portion including a head assembly (FIG. 3A) and a sensor cable to flex circuit interconnect (FIGS. 3B-C). As shown in FIG. 3A, a sensor head assembly 301 has a face tape 310, a flex circuit 320, a sensor cable 330, a stem tape 340, a base tape 350, a shell top 360 and a shell base 370. The face tape 310 and base tape 350 encase the flex circuit 320 and corresponding emitter and detectors. The shell top and base 360, 370 encase the sensor cable 330 to flex circuit 320 interconnect, described in further detail with respect to FIGS. 4A-B, below. The stem tape 340 encases the flex circuit 320 below the base tape 350.

[0030] FIG. 4 illustrates sensor flex circuit 320 to sensor cable 330 interconnection. The flex circuit 320 is positioned on mounting pins in the top shell 360 (FIG. 3B). As shown in FIG. 4, cable 330 wires are soldered to flex circuit pads 410, 420. Cable 330 Kevlar bundles are wrapped around a shell post 430 for strain relief and secured with adhesive. A detector shield flap 440 is folded over detector wires soldered to the detector pads 410 and secured with Kapton tape. The base shell 370 (FIG. 3B) is then glued in place over the top shell 360 (FIG. 3B). In the embodiment of FIG. 4, the

connections to the flex circuit **320** include four emitter anode conductors controlling four different wavelength emitters, a common emitter cathode conductor and an emitter shield, two near-field detector conductors, two far-field detector conductors and a detector shield. In an embodiment, the emitter and detector connections are physically separated between different circuit pads, for example, pads **410** and **420**. This reduces and/or prevents cross talk and noise between the emitter lines and the detector lines. Of course a person of skill in the art will understand from the present disclosures that different numbers and types of connectors can be used with the presently described connection system.

[0031] FIGS. 5A-H illustrate an emitter lens and a near-field detector lens **500** having a generally half-dome focus element **501** and a generally rectangular, planar base **502**. As described above, the lens base **502** is disposed over the flex-circuit-mounted emitter and near-field detector in order to focus emitted and detected light. Also as described above, the lens focus element **501** is configured to gently press into a tissue site when applied to the patient in order to maximize optical transmission via the skin surface. The focus elements can also use different three dimensional shapes as well in order to improve optical coupling with the skin and the present disclosure is not limited to the specific embodiments disclosed herein. For example, the lens can be spherical, cubed, rectangular, square, circular oblong or any other shape to increase optical transmission with the skin.

[0032] FIGS. 6A-H illustrate a far-field detector lens **600** having a generally oblong, half-dome focus element **601** and a generally oblong, planar base **602**. As described above, the lens base **602** is disposed over the flex-circuit-mounted far-field detector so as focus detector received light. Also as described above, the lens focus element **601** gently presses into a tissue site in order to maximize optical transmission via the skin surface. Also, as described above with respect to FIG. 5, the present disclosure is not limited to the specific dimensions and shape described herein which are provided for illustrative purposes. Rather, as discussed above, the present disclose extends to other shapes and sizes of a focus element that will improve optical coupling. Moreover, the focus element **601** can comprise two or more different focus elements instead of a single larger focus element.

[0033] FIG. 7 illustrates a regional oximetry sensor **700** attached to a tissue site **70** so as to generate near-field **760** and far-field **770** emitter-to-detector optical paths through the tissue site **70**. The resulting detector signals are processed so as to calculate and display oxygen saturation (SpO_2), delta oxygen saturation (ΔSpO_2) and regional oxygen saturation (rSO_2), as shown in FIG. 8C, below. The regional oximetry sensor **700** has a flex circuit layer **710**, a tape layer **720**, an emitter **730**, a near-field detector **740** and a far-field detector **750**. The emitter **730** and detectors **740**, **750** are mechanically and electrically connected to the flex circuit **710**. The tape layer **720** is disposed over and adheres to the flex circuit **710**. Further, the tape layer **720** attaches the sensor **700** to the skin **70** surface.

[0034] As shown in FIG. 7, the emitter **730** has a substrate **732** mechanically and electrically connected to the flex circuit **710** and a lens **734** that extends from the tape layer **720**. Similarly, each detector **740**, **750** has a substrate **742**, **752** and each has a lens **744**, **754** that extends from the tape layer. In this manner, the lenses **734**, **744**, **754** press against the skin **70**, advantageously increasing the optical transmission and reception of the emitter **730** and detectors **740**, **750**

through improved optical coupling. The lenses press into the skin and provide a more direct angle of light propagation through the skin between the emitter and detectors.

[0035] FIGS. 8A-B illustrate regional oximetry monitor embodiments for designating adult and child sensor placement sites. As shown in FIG. 8A, an adult form **801** is generated on a user interface display. Between one and four sensor sites can be designated on the adult form **801**, including left and right forehead **810**, forearm **820**, chest **830**, upper leg **840**, upper calf **850** and calf **860** sites. Accordingly, between one and four sensors **200** (FIGS. 2A-C) can be located on these sites. A monitor in communication with these sensors then displays between one and four corresponding regional oximetry graphs and readouts, as described with respect to FIG. 8C, below. As illustrated in FIGS. 8A-8C, the sensor can be positioned on a patient so that the sensor stem **220** and attached cabling can extend radially out from the body on the various regional oximetry sensor sites. This configuration reduces patient discomfort by preventing wiring from crossing or crisscrossing over a patient face, torso or lower body. This configuration also reduces the potential for entanglement of wires from the multiple sensors and associated cabling.

[0036] As shown in FIG. 8B, a child form **802** is generated on a user interface display. Between one and four sensor sites can be designated on the child form **802**, including left and right forehead **810**, left and right renal **870**, and left and right abdomen **880** sites. Any number of regional oximetry sensors can be deployed on a patient at the same time, but generally, between one and four sensors **200** (FIGS. 2A-C) are located on these sites at a given time. A monitor in communication with these sensors then displays between a corresponding regional oximetry graphs and readouts for each sensor, as described with respect to FIG. 8C, below. The displays of FIGS. 8A and 8B can also be selectively shown such that, for example, only an upper torso portion of the graphic is shown to prevent confusion by a care provider.

[0037] FIG. 8C illustrates a regional oximetry display **800** embodiment for monitoring parameters derived from between one and four regional oximetry sensors **200** (FIGS. 2A-C). This particular example is a two sensor display for monitoring, for example, a forehead left **811** site and a forehead right **831** site. In an upper display portion, the forehead left **812** site displays, for example, an SpO_2 graph **812**, an rSO_2 graph **814** and an rSO_2 readout **816**. Similarly, the forehead right **831** site displays, for example, an SpO_2 graph **832**, an rSO_2 graph **834** and an rSO_2 readout **836**.

[0038] Also shown in FIG. 8C, in a lower display portion, the forehead left **851** site displays, for example, an SpO_2 readout **852**, a ΔSO_2 readout **854** and a Δ_{base} readout **856**. Similarly, the forehead right **830** site displays, for example, an SpO_2 readout **872**, a ΔSO_2 readout **874** and a Δ_{base} readout **876**.

[0039] FIGS. 9A-B illustrate a problem that arises with a regional oximetry sensor **200** during use. The connector **250** is fixedly connected to a physiological monitor (not shown) that provides a read-out of parameters derived from the sensor **200**. Patient movement away from the monitor may occur in a manner that pulls on the cable (not shown) and bends the attached stem **220** up and/or over the sensor head **210** (FIG. 9A). Continued patient movement away from the monitor may cause a portion of the sensor head **901** to peel off of the patient's skin (FIG. 2B), disrupting accurate

parameter measurements. Indeed, continued patient movement may completely dislodge the sensor head **210** from the patient.

[0040] A peel-off resistant regional oximetry sensor has a sensor head attachable to a patient skin surface so as to transmit optical radiation into the skin and receive that optical radiation after attenuation by blood flow within the skin. A stem extending from the sensor head transmits electrical signals between the sensor head and an attached cable. The stem is terminated interior to the sensor head and away from a sensor head edge so as to define feet along either side of the stem distal the stem termination. The stem interior termination substantially transforming a peel load on a sensor head adhesive to less challenging tension and shear loads on the sensor head adhesive.

[0041] FIG. 10 illustrates an advantageous peel-off resistant regional oximetry sensor **1000** embodiment having a sensor head **1010**, stem **1020**, shell **230**, cable **240** and connector **250**. The sensor head **1010** houses an emitter, a near-field detector and a far-field detector within a layered tape having a top side and an adhesive bottom side disposed on a release liner, similar to that described with respect to FIGS. 2A-B, above. The peel-off resistant regional oximetry sensor **1000** has peel-resistant feet **1012** proximately disposed on either side of the stem. The feet are defined by stem slots **1014** separating the feet from the stem. This configuration advantageously moves the stem **1020** base from the edge of the sensor head (e.g. **210** FIG. 2A) to the interior of the sensor head **1010**. As a result, potential peel loads on the sensor head adhesive resulting from the stem **1020** being pulled over the sensor head are substantially reduced, as described with respect to FIGS. 12A-13B, below.

[0042] FIGS. 11A-B illustrate a peel-off resistant regional oximetry sensor **1000** adhering to a skin-surface monitoring site despite a pulling force applied to the sensor stem **1020** and interconnecting sensor cable. Patient movement relative to connected monitor tends to cause the stem **1020** to peel up the sensor head (see FIG. 2B, above). The sensor head feet **1012**, however, advantageously extend away from the point where the stem **1020** begins applying a load to the sensor head adhesive, thus counteracting the peel away force. Further the resulting adhesive loads are different in kind and magnitude than the adhesive loads on the sensor head shown and described with respect to FIG. 2, above. Comparative adhesive loads are described in detail with respect to FIGS. 12A-13B, below.

[0043] FIGS. 12A-13B illustrate comparative adhesive loads applied to a regional oximetry sensor and a peel-off resistant regional oximetry sensor resulting from cable forces applied to the sensor head stems **220** (FIGS. 12A-B), **1020** (FIGS. 13A-B). As shown in FIGS. 12A-B, the stem **220** applies a substantial peel load **221** to the sensor head **210** adhesive **222**, and the peel load **221** is distributed over a relatively small area **223** of the sensor head **210**. It is well-known that a peel load **221** is a substantial challenge to any adhesive, and the milder adhesives used on skin cannot easily overcome this challenge. As such, it is relatively easy for the sensor head **210** to become dislodged or completely detached from the patient.

[0044] As shown in FIGS. 13A-B, the stem **1020** applies different loads **1021** to the sensor head **310** adhesive **322**, **323**, **324** than described with respect to FIGS. 12A-B. In particular, there is a marginal peel load on the adhesive as the result of the adhesive feet **1012** positioned opposite the

connection point of the stem **1020** to the sensor head **1010**. The sheer load due to the stem force **1021** is much less challenging to the feet adhesive **1024** compared to a peel load. Likewise, the tension load due to the stem force **1021** is less challenging to the feet adhesive **1022**, **1023**, compared to a peel load, and that tension load is distributed on both sides of the stem-to-head connection point. That is, the cumulative effect of positioning the stem **1020** somewhat to the interior of the sensor head **1010** and behind the feet **1021** is a greatly diminished adhesive peel load and much less challenging shear and tension loads distributed over a larger adhesive footprint. The advantageous result is a sensor head-to-cable stem interface that is much less likely to dislodge the sensor head from the patient when forces are applied to the sensor cable. Further, more skin-friendly adhesives can be utilized for sensor head attachment as a result of lowered adhesive loads.

[0045] A peel-off resistant regional oximetry sensor has been disclosed in detail in connection with various embodiments. These embodiments are disclosed by way of examples only and are not to limit the scope of this disclosure or the claims that follow. One of ordinary skill in art will appreciate many variations and modifications.

Terminology

[0046] Embodiments have been described in connection with the accompanying drawings. However, it should be understood that the figures are not drawn to scale. Distances, angles, etc. are merely illustrative and do not necessarily bear an exact relationship to actual dimensions and layout of the devices illustrated. In addition, the foregoing embodiments have been described at a level of detail to allow one of ordinary skill in the art to make and use the devices, systems, etc. described herein. A wide variety of variation is possible. Components, elements, and/or steps can be altered, added, removed, or rearranged. While certain embodiments have been explicitly described, other embodiments will become apparent to those of ordinary skill in the art based on this disclosure.

[0047] Conditional language used herein, such as, among others, “can,” “could,” “might,” “may,” “e.g.,” and the like, unless specifically stated otherwise, or otherwise understood within the context as used, is generally intended to convey that certain embodiments include, while other embodiments do not include, certain features, elements and/or states. Thus, such conditional language is not generally intended to imply that features, elements and/or states are in any way required for one or more embodiments or that one or more embodiments necessarily include logic for deciding, with or without author input or prompting, whether these features, elements and/or states are included or are to be performed in any particular embodiment.

[0048] Depending on the embodiment, certain acts, events, or functions of any of the methods described herein can be performed in a different sequence, can be added, merged, or left out altogether (e.g., not all described acts or events are necessary for the practice of the method). Moreover, in certain embodiments, acts or events can be performed concurrently, e.g., through multi-threaded processing, interrupt processing, or multiple processors or processor cores, rather than sequentially.

[0049] The various illustrative logical blocks, engines, modules, circuits, and algorithm steps described in connection with the embodiments disclosed herein can be imple-

mented as electronic hardware, computer software, or combinations of both. To clearly illustrate this interchangeability of hardware and software, various illustrative components, blocks, modules, circuits, and steps have been described above generally in terms of their functionality. Whether such functionality is implemented as hardware or software depends upon the particular application and design constraints imposed on the overall system. The described functionality can be implemented in varying ways for each particular application, but such implementation decisions should not be interpreted as causing a departure from the scope of the disclosure.

[0050] The various illustrative logical blocks, modules, and circuits described in connection with the embodiments disclosed herein can be implemented or performed with a general purpose processor, a digital signal processor (DSP), an application specific integrated circuit (ASIC), a field programmable gate array (FPGA) or other programmable logic device, discrete gate or transistor logic, discrete hardware components, or any combination thereof designed to perform the functions described herein. A general purpose processor can be a microprocessor, but in the alternative, the processor can be any conventional processor, controller, microcontroller, or state machine. A processor can also be implemented as a combination of computing devices, e.g., a combination of a DSP and a microprocessor, a plurality of microprocessors, one or more microprocessors in conjunction with a DSP core, or any other such configuration.

[0051] The blocks of the methods and algorithms described in connection with the embodiments disclosed herein can be embodied directly in hardware, in a software module executed by a processor, or in a combination of the two. A software module can reside in RAM memory, flash memory, ROM memory, EPROM memory, EEPROM memory, registers, a hard disk, a removable disk, a CD-ROM, or any other form of computer-readable storage medium known in the art. An exemplary storage medium is coupled to a processor such that the processor can read information from, and write information to, the storage medium. In the alternative, the storage medium can be integral to the processor. The processor and the storage medium can reside in an ASIC. The ASIC can reside in a user terminal. In the alternative, the processor and the storage medium can reside as discrete components in a user terminal.

[0052] While the above detailed description has shown, described, and pointed out novel features as applied to various embodiments, it will be understood that various omissions, substitutions, and changes in the form and details of the devices or algorithms illustrated can be made without departing from the spirit of the disclosure. As will be recognized, certain embodiments of the inventions described herein can be embodied within a form that does not provide all of the features and benefits set forth herein, as some features can be used or practiced separately from others. The scope of certain inventions disclosed herein is indicated by the appended claims rather than by the foregoing description. All changes which come within the meaning and range of equivalency of the claims are to be embraced within their scope.

1-9. (canceled)

10. A regional oximetry sensor comprising:

a face tape layer;

a base tape layer adhesively attachable to a patient skin surface;

at least one emitter configured to transmit optical radiation in to the patient skin surface;

a near-field detector configured to detect the optical radiation after attenuation by tissue of the patient;

a far field detector also configured to detect the optical radiation after attenuation by tissue of the patient; and wherein the face tape layer and the base tape layer cooperate together and include a plurality of notches forming a plurality of cutouts.

11. The regional oximetry sensor of claim 10, wherein the plurality of notches forming the plurality of cutouts are formed on a periphery of the base and face tape layers.

12. The regional oximetry sensor of claim 11, wherein the cutouts are mechanically decoupled from each other.

13. The regional oximetry sensor of claim 12, wherein the cutouts allow for ease of patient movement of the measurement site.

14. A peel-off resistant regional oximetry sensor comprising:

a sensor head attachable to a patient skin surface and configured to transmit optical radiation into the skin and receive that optical radiation after attenuation by blood flow within the skin; and

a stem extending from the sensor head and configured to transmit electrical signals between the sensor head and an attached cable;

wherein the stem is terminated interior to the sensor head and away from an edge of the sensor head so as to define feet along either side of the stem distal the stem termination.

15. The regional oximetry sensor of claim 14, wherein the sensor head and stem form a single continuous body.

16. The regional oximetry sensor of claim 14, wherein the sensor head and stem are substantially flat.

17. The regional oximetry sensor of claim 14, wherein the stem extends radially outward from the sensor head.

18. A peel-off resistant regional oximetry sensor comprising:

a face tape layer;

a base tape layer adhesively attachable to a patient skin surface, the face tape layer and base tape layer cooperating to form a sensor head and stem, the sensor head including notches on either side of the stem at the junction of the sensor head and stem, the notches mechanically decoupling the sensor stem from a radial edge of the sensor head;

at least one emitter configured to transmit optical radiation in to the patient skin surface;

a near-field detector configured to detect the optical radiation after attenuation by tissue of the patient; and

a far field detector also configured to detect the optical radiation after attenuation by tissue of the patient.

19. The regional oximetry sensor of claim 18, wherein the sensor head and stem form a single continuous body.

20. The regional oximetry sensor of claim 18, wherein the sensor head and stem are substantially flat.

21. The regional oximetry sensor of claim 18, wherein the stem extends radially outward from a distal portion of the sensor head.

* * * * *

专利名称(译)	区域血氧测量传感器		
公开(公告)号	US20180168491A1	公开(公告)日	2018-06-21
申请号	US15/891910	申请日	2018-02-08
[标]申请(专利权)人(译)	梅西莫股份有限公司		
申请(专利权)人(译)	Masimo公司		
当前申请(专利权)人(译)	Masimo公司		
[标]发明人	AL ALI AMMAR FORREST KEVIN ABDUL HAFIZ YASSIR WEBER WALTER M MANGOSING PETE HWANG SUJIN		
发明人	AL-ALI, AMMAR FORREST, KEVIN ABDUL-HAFIZ, YASSIR WEBER, WALTER M. MANGOSING, PETE HWANG, SUJIN		
IPC分类号	A61B5/145 A61B5/00 A61B5/1455 H01R13/52		
CPC分类号	A61B5/6833 A61B5/14553 H01R2201/12 A61B2562/228 A61B2562/227 A61B2562/225 A61B2562/222 A61B2562/22 H01R13/5224 A61B5/14557 A61B5/14551 A61B5/1455 A61B5/746 A61B5/7275 A61B5 /14542 A61B5/742 A61B5/14552		
优先权	62/012170 2014-06-13 US 61/887878 2013-10-07 US 61/887856 2013-10-07 US 61/887883 2013-10-07 US		
其他公开文献	US10617335		
外部链接	Espacenet USPTO		

摘要(译)

局部血氧测定传感器具有可附接到患者皮肤表面的传感器头，以便将光辐射传输到皮肤中并在被皮肤内的血流衰减之后接收该光辐射。传感器包括压入皮肤的窗口，以最大限度地提高光传输。从传感器头部伸出的杆在传感器头部和连接的电缆之间传输电信号。在抗剥离构型中，杆在传感器头的内部终止并且远离传感器头部边缘，以便沿杆的远离杆端部的任一侧限定脚。杆内部终端将传感器头粘合剂上的剥离负载转化为传感器头粘合剂上更难以承受的张力和剪切负载。

